



---

# Laing Thermotech ACT-4 wireless Potable Hot Water Recirculation Kit

---

Laing Thermotech  
a xylem brand



# Table of Contents

<b>Introduction and Safety</b> .....	<b>2</b>
Introduction.....	2
Safety.....	2
Safety terminology and symbols.....	2
User safety.....	3
Environmental safety.....	4
<b>Product Description</b> .....	<b>6</b>
General description.....	6
Operational specifications.....	6
<b>Installation</b> .....	<b>9</b>
Preinstallation.....	9
Recommended installation.....	10
Install the pump.....	11
Install the valve.....	12
<b>Commissioning, Startup, Operation, and Shutdown</b> .....	<b>15</b>
Thermostat controlled operation.....	15
Thermostat controlled operation <b>Plus</b> Timer.....	15
Optional Push-Button / Signal Repeater.....	17
<b>Maintenance</b> .....	<b>19</b>
Valve and pump inspection.....	19
Pairing after pump or valve replacement.....	19
Replace the batteries.....	19
Return to service after shutdown of two weeks or more.....	20
<b>Troubleshooting</b> .....	<b>21</b>
LED codes.....	21
Operation troubleshooting.....	21

# Introduction and Safety

## Introduction

### Purpose of this manual

The purpose of this manual is to provide necessary information for:

- Installation
- Operation
- Maintenance



---

#### CAUTION:

Read this manual carefully before installing and using the product. Improper use of the product can cause personal injury and damage to property, and may void the warranty.

---

---

#### NOTICE:

Save this manual for future reference, and keep it readily available at the location of the unit.

---

## Safety



---

#### WARNING:

- The operator must be aware of safety precautions to prevent physical injury.
  - Any pressure-containing device can explode, rupture, or discharge its contents if it is over-pressurized. Take all necessary measures to avoid over-pressurization.
  - Operating, installing, or maintaining the unit in any way that is not covered in this manual could cause death, serious personal injury, or damage to the equipment. This includes any modification to the equipment or use of parts not provided by Xylem. If there is a question regarding the intended use of the equipment, please contact a Xylem representative before proceeding.
  - Do not change the service application without the approval of an authorized Xylem representative.
- 
- 



---

#### CAUTION:

You must observe the instructions contained in this manual. Failure to do so could result in physical injury, damage, or delays.

---



## Safety terminology and symbols

### About safety messages

It is extremely important that you read, understand, and follow the safety messages and regulations carefully before handling the product. They are published to help prevent these hazards:

- Personal accidents and health problems
- Damage to the product
- Product malfunction

## Hazard levels

Hazard level	Indication
 <p><b>DANGER:</b></p>	A hazardous situation which, if not avoided, will result in death or serious injury
 <p><b>WARNING:</b></p>	A hazardous situation which, if not avoided, could result in death or serious injury
 <p><b>CAUTION:</b></p>	A hazardous situation which, if not avoided, could result in minor or moderate injury
<b>NOTICE:</b>	<ul style="list-style-type: none"> <li>• A potential situation which, if not avoided, could result in undesirable conditions</li> <li>• A practice not related to personal injury</li> </ul>

## Hazard categories

Hazard categories can either fall under hazard levels or let specific symbols replace the ordinary hazard level symbols.

Electrical hazards are indicated by the following specific symbol:



Electrical Hazard:

These are examples of other categories that can occur. They fall under the ordinary hazard levels and may use complementing symbols:

- Crush hazard
- Cutting hazard
- Arc flash hazard

## User safety

### General safety rules

These safety rules apply:

- Always keep the work area clean.
- Pay attention to the risks presented by gas and vapors in the work area.
- Avoid all electrical dangers. Pay attention to the risks of electric shock or arc flash hazards.
- Always bear in mind the risk of drowning, electrical accidents, and burn injuries.

### Safety equipment

Use safety equipment according to the company regulations. Use this safety equipment within the work area:

- Hard hat
- Safety goggles, preferably with side shields
- Protective shoes

- Protective gloves
- Gas mask
- Hearing protection
- First-aid kit
- Safety devices

---

**NOTICE:**

Never operate a unit unless safety devices are installed. Also see specific information about safety devices in other chapters of this manual.

---

**Electrical connections**

Electrical connections must be made by certified electricians in compliance with all international, national, state, and local regulations. For more information about requirements, see sections dealing specifically with electrical connections.

**Precautions before work**

Observe these safety precautions before you work with the product or are in connection with the product:

- Provide a suitable barrier around the work area, for example, a guard rail.
- Make sure that all safety guards are in place and secure.
- Make sure that you have a clear path of retreat.
- Make sure that the product cannot roll or fall over and injure people or damage property.
- Make sure that the lifting equipment is in good condition.
- Use a lifting harness, a safety line, and a breathing device as required.
- Allow all system and pump components to cool before you handle them.
- Make sure that the product has been thoroughly cleaned.
- Disconnect and lock out power before you service the pump.
- Check the explosion risk before you weld or use electric hand tools.

**Wash the skin and eyes**

Follow these procedures for chemicals or hazardous fluids that have come into contact with your eyes or your skin:

Condition	Action
Chemicals or hazardous fluids in eyes	<ol style="list-style-type: none"><li>1. Hold your eyelids apart forcibly with your fingers.</li><li>2. Rinse the eyes with eyewash or running water for at least 15 minutes.</li><li>3. Seek medical attention.</li></ol>
Chemicals or hazardous fluids on skin	<ol style="list-style-type: none"><li>1. Remove contaminated clothing.</li><li>2. Wash the skin with soap and water for at least 1 minute.</li><li>3. Seek medical attention, if necessary.</li></ol>

## Environmental safety

**The work area**

Always keep the station clean.

**Waste and emissions regulations**

Observe these safety regulations regarding waste and emissions:

- Appropriately dispose of all waste.
- Handle and dispose of the processed liquid in compliance with applicable environmental regulations.

- Clean up all spills in accordance with safety and environmental procedures.
- Report all environmental emissions to the appropriate authorities.

**WARNING:**

Radiation Hazard. Do NOT send the product to Xylem if it has been exposed to any nuclear radiation.

**Electrical installation**

For electrical installation recycling requirements, consult your local electric utility.

**Recycling guidelines**

Always follow local laws and regulations regarding recycling.

**FCC Statement (United States Only)**

This device complies with Part 15 of the FCC Rules. Operation is subject to the following two conditions:

1. this device may not cause harmful interference and
2. this device must accept any interference received, including interference that may cause undesired operation.

This equipment has been tested and found to comply with the limits for a Class B digital device, pursuant to Part 15 of the FCC Rules. These limits are designed to provide reasonable protection against harmful interference in a residential installation. This equipment generates, uses and can radiate radio frequency energy and, if not installed and used in accordance with the instructions, may cause harmful interference to radio communications. However, there is no guarantee that interference will not occur in a particular installation. If this equipment does cause harmful interference to radio or television reception, which can be determined by turning the equipment off and on, the user is encouraged to try to correct the interference by one or more of the following measures:

- Reorient or relocate the receiving antenna.
- Increase the separation between the equipment and receiver.
- Consult the dealer or an experienced radio/TV technician for help.

Changes or modifications not expressly approved by the manufacturer responsible for compliance could void the user's authority to operate the equipment.

**Certifications**

CSA Certified: NSF/ANSI-372 Compliant

**Industry Canada RSS Statement (Canada Only)**

This device complies with Industry Canada licence-exempt RSS standard(s). Operation is subject to the following two conditions: (1) this device may not cause interference, and (2) this device must accept any interference, including interference that may cause undesired operation of the device.

# Product Description

## General description

The ACT-4 wireless is a potable hot water recirculation kit for use in new and retrofit domestic hot water systems. The kit helps to:

- Improve comfort through instant hot water
- Save energy
- Conserve water

### Parts included in kit

- Pump with a built-in timer
- 6 ft (1.8 m) power cord
- Under-sink mixing valve with transmitter/receiver
- Two 1.5V LR06 AA Batteries
- Valve mounting bracket
- Two screws
- Installation, Operation, and Maintenance Manual (IOM)

### Additional parts needed for install

- (2) 3/8" Compression x 1/2" stainless steel flex hoses
- (2) 1/2" x 1/2" stainless steel flex hoses (optional)
- Hand tools including various wrenches and #0 and #2 Phillips Head screwdrivers
- (1) 3/4" Isolation shut-off valve and associated adapters and nipples (optional - if pump desired to be isolated for maintenance)

Verify the type of 1/2" connection that may be required for the stainless steel flex hoses: Compression or NPT/IPS.

## Operational specifications

### Operational limits

Pump and valve	
Operating medium	Water
Maximum working pressure	145 PSI (10 bar)
Minimum operating differential pressure (Valve)	1.6 PSI (0.11 bar)
Maximum water temperature	203°F (95°C)
Motor	115 V, 1 PH, 60 Hz, 20 Watts input, 0.3 Amps, 4800 RPM
Operating noise level	30 dB
Battery power	1.5 V each
Estimated battery life	2 Years
Maximum operating range	150 ft (45 m)



**WARNING:**

Do NOT exceed the maximum working pressure of the pump. This information is listed on the nameplate of the pump.

---

**WARNING:**

California Proposition 65 warning! This product contains chemicals known to the state of California to cause cancer and birth defects or other reproductive harm.

---

**How the system works**

The ACT-4 wireless potable hot water recirculation kit features a factory paired pump and mixing valve that wirelessly communicate temperature data and operational status between each other. The ACT-4 wireless pump with built-in timer is installed on the supply side of the hot water source, as presented below. The paired mixing valve is installed under the sink farthest from the hot water source. A temperature sensor within the valve detects the water temperature and wirelessly transmits this data to the pump.

The desired water temperature at the mixing valve is set remotely with the thermostat dial on the pump. When the water temperature sensed at the valve is below the desired setting, a signal is sent to the ACT-4 wireless pump to begin circulating hot water throughout the system. The mixing feature of the valve tempers the cold water at the faucet or tap, providing instant hot water at this location and so satisfying the need for hot water at all upstream water outlets. When the temperature requirement at the valve has been satisfied, a signal is sent to turn off the pump. This system prevents continuous running and saves energy.

For more energy savings, the ACT-4 wireless pump can be set for Timer Operation to run only during the time periods when hot water is most frequently required.

An optional push-button / signal repeater device is available to provide instant hot water with a touch of a button. Pressing the push-button will activate the pump and begin circulating hot water throughout the system, outside of the set Timer Operation, until the desired temperature is met at the valve. Acting in its secondary function as a signal repeater, this device will also extend the operational range of the pump and valve and aid in the transmission of data between the two devices where necessary.

The instant hot water delivery with the ACT-4 wireless potable hot water recirculation kit saves water and time, while improving comfort, as water does not need to run continuously while waiting for it to warm up.

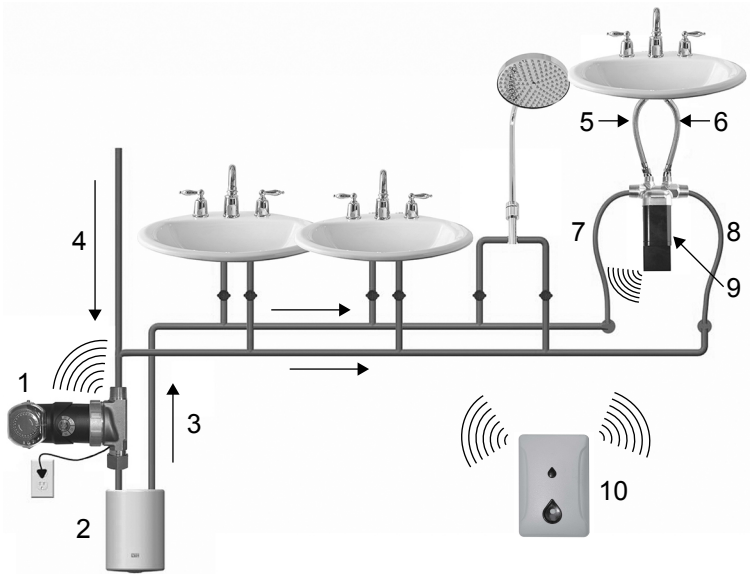

1. ACT-4 wireless pump
2. Hot water source
3. Hot water
4. Cold water
5. Hot water flex hose
6. cold water flex hose
7. Hot water supply hose
8. Cold water supply hose
9. ACT-4 wireless mixing valve
10. Optional push-button / repeater

---

# Installation

## Preinstallation



---

**CAUTION:**

All work must be performed by qualified personnel trained in the proper application, installation, and maintenance of plumbing, steam and electrical equipment or systems in accordance with all applicable codes and regulations.

---

The pump and valve as received in this kit are factory paired and wirelessly communicate water temperature and pump status with each other.

Before installation of the pump and valve, complete the following:

- Shut off water supply.
- Turn off hot water source.
- Drain the lines.
- Allow the system to cool to a safe handling temperature, below 100°F (38°C) and a zero pressure condition.

## Recommended installation

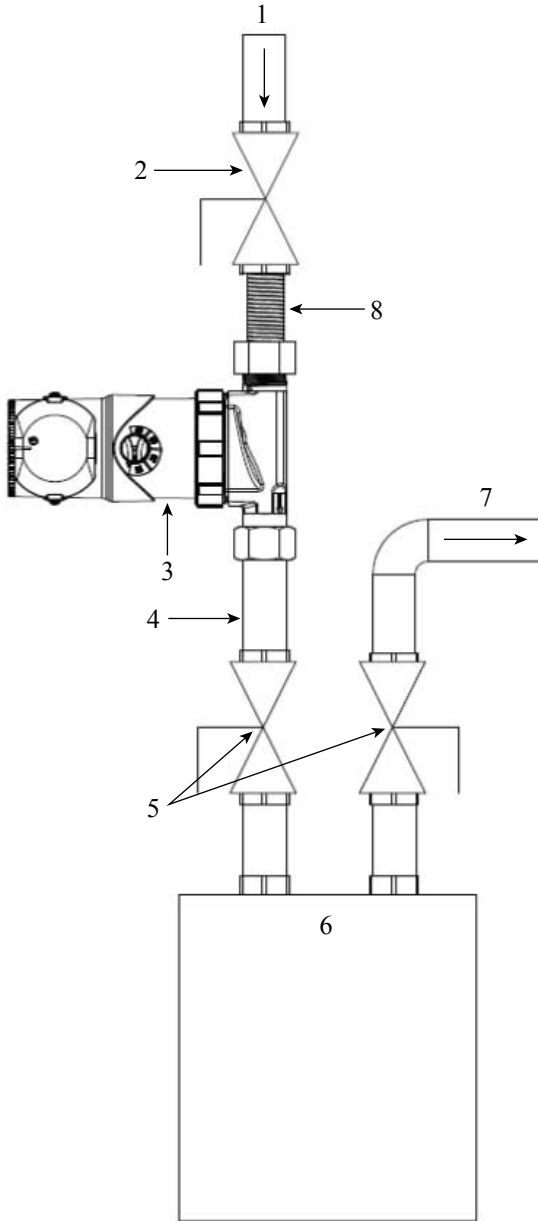

1. Cold water supply
2. 3/4" NPT isolation valve
3. ACT4 wireless pump

4. 3/4" NPT male adapter, if required
5. 3/4" NPT isolation valve
6. Hot water source
7. Hot water
8. Flexible supply line

## Install the pump

1. Remove the motor and timer unit, O-ring, and insert from the pump housing. Set these items aside.

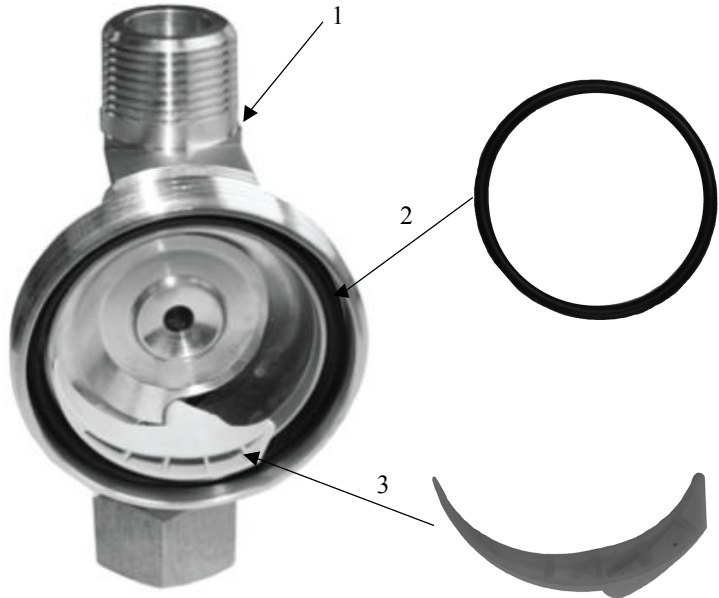

1. Pump housing
  2. Pump o-ring
  3. Pump insert
2. Connect the union end of the pump housing to the 3/4" NPT male inlet of the hot water source, or male adapter and isolation valve connected to the hot water source.  
Make sure that the arrow on the pump housing is properly oriented in the direction of the supply water flow.
  3. Connect flexible supply line to the 3/4" NPT male threads of the pump housing.  
Do not twist or excessively bend the hose. Replace the flexible hose with a shorter length if necessary. Use PTFE tape or pipe compound if necessary.
  4. Reattach the motor and timer unit, the insert, and the O-ring to the pump housing.

5. Orient the pump so that the timer is accessible. The timer should never be positioned in any orientation above the pump housing.



6. Make sure that the screw ring that attaches the motor to the pump is securely hand tightened. Do not attempt to further rotate the pump timer or the pump may be damaged.  
Over-tightening the pump screw ring can cause damage to the pump. Do not use pipe compound or plumber's putty on the screw ring.
7. Turn on the water supply to the hot water source and verify that there are no leaks at any connections.
8. Turn on the faucet/taps or shower farthest from the hot water source until there is a steady stream of water with no sputter or evidence of air in the lines.
9. Plug the pump cord into the wall outlet and start the system. In the event of a disruption in the power supply, the ACT-4 wireless pump will resume communication with the paired mixing valve.
10. Open the timer cover. Rotate the dial clockwise until the current time is aligned with the pointer at the top (12 o'clock position) of the dial.  
See Thermostat Controlled Operation PLUS Timer section below.

## Install the valve



1. Prepare the installation site, which is the faucet/tap farthest from the hot water source.
2. Close the hot and cold water riser shutoff valves and open the hot and cold water faucets/taps to relieve the water pressure. Close the water faucets/taps.  
In some older homes, the riser shutoff valves may be difficult to shut off completely. If so, turn off the water at the main water inlet valve to the house.
3. Remove the existing flexible line connections to the hot and cold water faucet/tap threaded nipples.  
Use a bucket to collect any excess drainage.
  - a) If necessary, replace existing flexible hoses with new stainless steel braided flexible hoses in the lengths required.
4. Screw on the two existing 1/2" hose connections to the corresponding hot and cold sides of the valve housing, denoted as "H" and "C" respectively. Grip the valve only by the brass hex feature during assembly.  
Be careful not to kink the existing hose lines while bending, which can prevent adequate flow and/or cause the valves to break.
  - a) Inspect the rubber washers in the hose connections to ensure that they are in reusable condition. If not, replace.



5. Screw the 3/8" compression end of the purchased flexible hoses to the 3/8" connections on the valve. Screw the 1/2" ends of these same two hoses to the underside of the hot and cold water faucet/tap respectively.
  - a) Make sure to match the hot and cold sides marked on the valve with the corresponding faucet/tap.
  - b) Make sure that the hot side connection is attached to the hot water faucet/tap and the cold water side connection is attached to the cold water faucet/tap
  - c) Make sure that the hoses are long enough to allow the valve to be positioned as planned.
6. If desired, fasten the valve to the wall or vanity cabinet using the optional mounting bracket and screws that are provided in the kit.

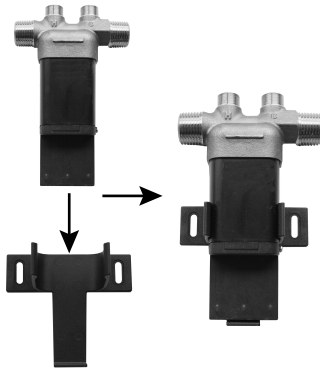

7. Open the faucet/tap and hot and cold water riser shutoff valves to purge any air entrained in the valve or hoses and to insure there are no leaks at any connections.
8. Remove the locking screw from the battery compartment cover on the valve. Insert the batteries in their proper orientation into the compartment on the valve. Be sure to match the positive (+) and negative (-) ends of the batteries with the corresponding polarity symbols on the bottom of the housing. Installing one battery in reverse will result in improper system operation. Return the locking screw to its proper position when the batteries have been installed.

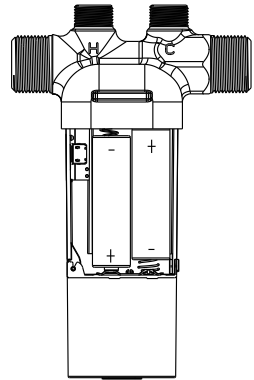

---

**CAUTION:**

Short circuit hazard. Improper battery installation may cause personal injury or property damage due to short circuit or battery leakage.

---

This installation method applies to most situations where faucets/taps are connected to hot and cold water supply lines with braided flexible hose/shut-off valve arrangements. If the under-sink arrangement is different, for example the risers are hard copper or plastic, then other parts not listed here may be required for the installation.



# Commissioning, Startup, Operation, and Shutdown

## Thermostat controlled operation

The valve and pump are ready to communicate with each other out of the box.

The pump comes with an adjustable temperature feature. This feature is controlled by the thermostat dial just above the timer housing on the body of the pump and may be set to activate between 86°F (30°C) and 95°F (35°C). This temperature range represents the desired water temperature to be sensed at the remotely set under-sink mixing valve.

- Slide the switch on the timer housing to the “ON” position.

In the “ON” position, the pump runs automatically whenever the built-in temperature sensor in the valve senses the need for hot water at the under-sink valve. In the “OFF” position, the pump does not operate at any time. In either instance, the LED light on the thermostat knob will remain steady.

The pump will most likely start running immediately and turn off after a few minutes when hot water reaches the faucet/tap. The pump continues cycling on and off as required during the programmed sequence of operation. (Do not be concerned if the pump does not begin to run immediately after the pump is plugged in, or at times throughout normal operation. This just means that there is already hot water at the hot water faucet/tap. The pump turns on automatically when the hot water line cools down.)

## Thermostat controlled operation Plus Timer

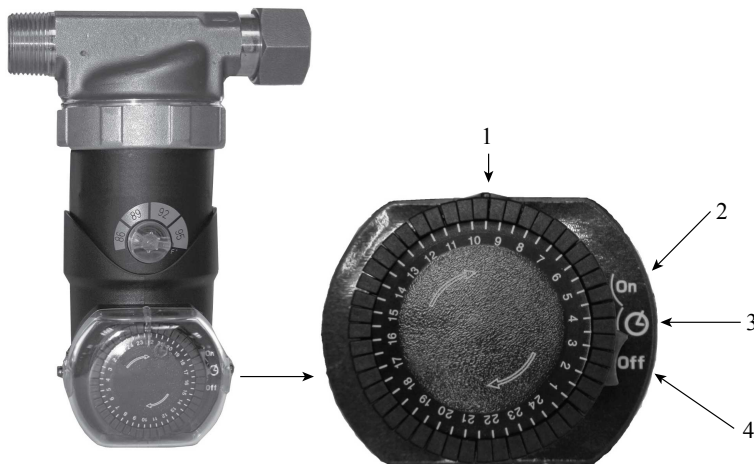

1. Set current time here
2. Pump runs when valve calls for hot water
3. Pump runs only during the desired times when valve calls for hot water
4. Pump does not run

1. Open the timer cover with a small flat head screwdriver. Verify that current time setting is correct. If not, rotate the dial clockwise until the correct time is aligned with the pointer at the top (12 o'clock position) of the dial.

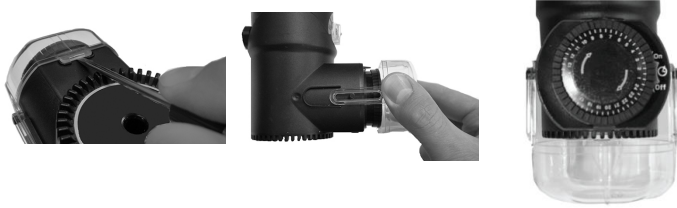

2. Automatic Operation: Pull the tabs out on the timer for the desired operating time. For example, if the desired operating time is 9:00 AM to 11:00 AM, pull out all tabs from 9 through 11.

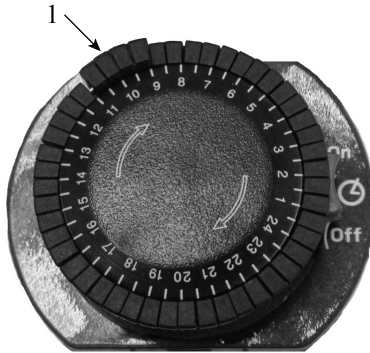

1. Pull tabs out for desired time



The timer can be set for multiple operating periods of time, in 1/2 hour increments.

3. Slide the switch bar to the clock symbol.

## Optional Push-Button / Signal Repeater

The pump and valve as received in this kit are factory paired and wirelessly communicate water temperature and pump status with each other. An optional push-button device is available to provide instant hot water regardless of the circulator pump's timer setting. This device also works as a signal repeater, extending the operational range between the pump and valve.

### Push-Button Operation

Follow this procedure when you add the push-button device to your system and pair it with your ACT4 wireless pump and valve:

1. Begin the pairing process by opening the timer cover on the pump and performing the following sequence with the pump timer switch:
  - a) Slide the switch from the "ON" position to the "OFF" position and wait two (2) seconds.
  - b) Slide the switch to the "ON" position and wait two (2) seconds.
  - c) Slide the switch to the "OFF" position and wait two (2) seconds.
  - d) Return the switch to the "ON" position. A series of rapid flashes from the LED light in the thermostat knob of the pump will indicate that it has entered pairing mode. The pump will remain in pairing mode for ten (10) minutes.
2. Power up the push-button / signal repeater device to be paired by plugging it directly into a nearby outlet. While plugging the push-button device into the outlet, depress and hold the push-button. Keep the push-button depressed for five (5) additional seconds. Pairing mode on the push-button / signal repeater is also indicated by a rapid series of flashes from its own LED light and will remain in pairing mode until it communicates and pairs with the pump.
3. Upon successful pairing, the LED light in the thermostat knob of the pump will produce a steady glow, indicating that the pump is running or is on stand-by. The LED light in the push-button device will produce a seldom flash when the system is on stand-by or a steady glow when the pump is running.

The push-button is now ready for service. Once the push-button / signal repeater has been paired with the pump, it can be relocated to the desired outlet without having to be re-paired.

The pump is capable of pairing with only two devices: the valve and the optional push-button / signal repeater.

### Signal Repeater Operation

When used as a signal repeater, the device will extend the operational range of the ACT4 wireless hot water recirculation kit beyond the normally specified distance. Device pairing is not required when used as a signal repeater. It will aid in the transmission of data between the pump and valve in environments where building construction or other factors may interfere with ongoing communication.

When used as a signal repeater, the device should be installed at an outlet at an intermediate location between the pump and valve.



# Maintenance

## Valve and pump inspection

Periodically inspect the valve or pump for signs of leakage or corrosion.



### WARNING:

Risk for property damage, serious personal injury or death. You must replace the valve or pump if corrosion or leakage is found.

## Pairing after pump or valve replacement

If either the pump or the valve is replaced, device pairing is required. To pair the devices, follow this procedure:

1. Power up the valve by inserting the batteries.
  - If the valve is already in operation, remove and reinsert the batteries. If the valve is being replaced, remove the batteries from the old valve before pairing the new replacement with the pump. It is recommended to use a fresh set of batteries in the new valve being installed.
    - a) If a push-button / signal repeater device requires pairing, plug it directly into the desired outlet.
2. Open the timer cover on the pump. Slide the switch from the "ON" position to the "OFF" position.
3. Wait two (2) seconds and slide the switch from the "OFF" position to the "ON" position.
4. Wait two (2) seconds and slide the switch to the "OFF" position.
5. Wait two (2) seconds and return the switch to the "ON" position.

When the device is successfully paired, the LED in the thermostat knob is lit. The pump is now ready for service.

## Replace the batteries

The system is designed to provide effective communication between the pump and valve for approximately two (2) years after system start-up or battery replacement when using two (2) 1.5 V LR06 alkaline batteries. When using rechargeable batteries, it is recommended that they have a minimum 2500 mAh capacity.

Do not mix new and old batteries or other makes of batteries, such as alkaline with lithium-ion. The different attributes can negatively affect the system performance or cause the batteries to leak fluid, overheat, or explode.

When new batteries are inserted into the valve, the valve will resume communication with the pump.



### CAUTION:

Risk of property damage or personal injury. You must replace the valve if battery leakage is found.

## Return to service after shutdown of two weeks or more

You may choose to turn the system off (slide the pump timer switch to the "OFF" position) as there is no need to maintain hot water in the supply line when no one is home. Before turning the system back on, follow these instructions:

1. Open the faucets/taps at the sink where the system is installed. Keep them open until all air is purged and the water flows smoothly.
2. Slide the pump switch back to either the "ON" position or the clock position for Timer Operation.

# Troubleshooting



## LED codes

Pump LED sequence code	Explanation
No light	Pump is off – no power
Steady light on LED	Pump is running or on stand-by
One short and one long flash	Low input voltage to pump
Two short and one long flash	Communication is lost between pump and valve
Three short and one long flash	Pump is overheated
Four short and one long flash	Pump is overloaded
Five short and one long flash	Blocked rotor inside pump
Six short and one long flash	Low battery voltage at the valve
Short fast flashes	Pump is in pairing mode

Repeater / push-button LED sequence code	Explanation
Steady light	System is running
Seldom flashes	System is running
Short fast flashes	Push-button / signal repeater is in pairing mode

## Operation troubleshooting

Symptom	Cause	Remedy
Pump does not turn on	Timer slide switch is set to "OFF" position or timer clock is not programmed to allow operation.	Set the slide switch to the "ON" position or program the timer clock.
	Water at the valve is already at the set temperature and does not require pump operation.	Pump will turn on when the water at the valve cools. Verify the temperature setting on the pump.
	Outlet has no power	Check that there is power at the outlet. Make sure the outlet that the pump is plugged into is not controlled by a wall switch.
	GFCI is tripped.	Verify the "TEST" and "RESET" of the GFCI outlet that the pump is plugged into.

Symptom	Cause	Remedy
Pump is noisy	Air in the system	Turn off the ecocirc pump. Turn on the hot and cold faucets/taps until all air is purged from the system.
	Foreign matter in the rotor cavity 	Unplug pump and shut off water supply. Open faucets/taps and drain water from the piping. Loosen the screw ring to separate motor from the pump housing and check for foreign matter.
	Rotor does not seat properly. 	Ensure the rotor is properly set on the motor bearing by pushing down on the rotor.
	Water hammer that results from the closure of the built-in check valve.	Install water hammer arresters on the hot and cold lines.
Hot water is not instantly available at all faucets/taps	Faucets/taps are branched off from the main hot water supply line.	Hot water will take longer to reach branched faucets/taps.
	Water temperature at the valve is at or above the set temperature.	Verify the temperature setting at the pump.
	Hot water source not producing hot water.	Verify temperature setting at hot water source. Verify hot water source operation.
	Distance between the pump and valve is greater than 150 ft (45 m).	Install a signal repeater / push-button to assist communication between pump and valve.
Water at faucets/tap is too hot	The temperature setting on the hot water source is too high.	Adjust temperature setting on hot water source.



Symptom	Cause	Remedy
Pump is overheated	Hot water source is generating too much heat.	Adjust temperature setting on hot water source.
	Ambient temperature is too hot.	Make sure the pump and hot water source are properly ventilated to allow cooling.
	Pump is overloaded.	See possible causes and remedies below.
Communication is lost between pump and valve	Batteries are dead/Low battery voltage.	Replace batteries.
	Incorrect battery orientation.	Verify correct battery orientation.
	Distance between the pump and valve is greater than 150 ft (45m) or disruptive media interferes with communication.	Install a push-button / signal repeater to assist communication between pump and valve
Pump is overloaded	Improper power to pump outlet	Consult electrician to determine cause.
	Pump rotor is not freely rotating.	<ol style="list-style-type: none"> <li>1. Unplug pump and shut off water supply.</li> <li>2. Open faucets/taps and drain water from the piping.</li> <li>3. Loosen the screw ring to separate motor from the pump housing.</li> <li>4. Verify that the pump rotor is seated properly and there is no debris.</li> <li>5. Rotate the pump rotor counter-clockwise for three or four revolutions to make sure it can freely spin.</li> </ol>
Blocked rotor inside pump	Foreign matter in the rotor cavity	<ol style="list-style-type: none"> <li>1. Unplug pump and shut off water supply.</li> <li>2. Open faucets/taps and drain water from the piping.</li> <li>3. Loosen the screw ring to separate motor from the pump housing and check for foreign matter.</li> </ol>
Low input voltage to pump	Improper power to pump outlet	Consult electrician to determine cause.



**WARNING:**

Extreme temperature hazard. Water temperature above 125°F (51°C) can cause severe burns or scalding instantly.





# Xylem |'zīləm|

- 1) The tissue in plants that brings water upward from the roots
- 2) A leading global water technology company

We're 12,000 people unified in a common purpose: creating innovative solutions to meet our world's water needs. Developing new technologies that will improve the way water is used, conserved, and re-used in the future is central to our work. We move, treat, analyze, and return water to the environment, and we help people use water efficiently, in their homes, buildings, factories and farms. In more than 150 countries, we have strong, long-standing relationships with customers who know us for our powerful combination of leading product brands and applications expertise, backed by a legacy of innovation.

**For more information on how Xylem can help you, go to [xyleminc.com](http://xyleminc.com)**



Xylem Inc.  
3873 Willow, Suite #104  
Fresno, CA 93725  
Tel: 1-559-265-4730  
Fax: 1-800-453-4730  
<http://unitedstates.xylemappliedwater.com/brands/laing-thermotech/>

Visit our Web site for the latest version of this document and more information

The original instruction is in English. All non-English instructions are translations of the original instruction.

© 2013 Xylem Inc

Laing Thermotech is a trademark of Xylem Inc or one of its subsidiaries.

671075145\_B