

Horizon™ Ice Machine Installation Instructions for Remote Condensing Unit

HCD/HMD/HCF/HMF1000R _ _
 HCD/HMD/HCF/HMF1400R _ _
 HCD/HMD/HCF/HMF1650R _ _

(See model number configurator on page 2 for details.)

Order parts online
www.follettice.com

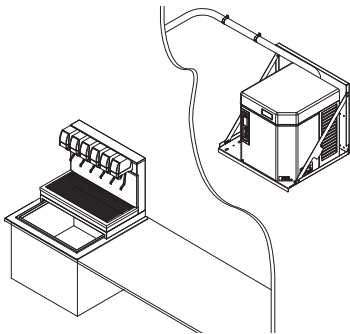
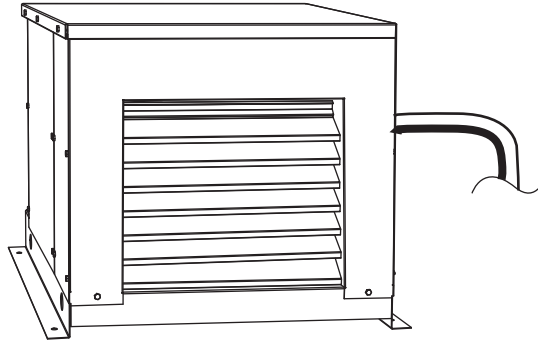
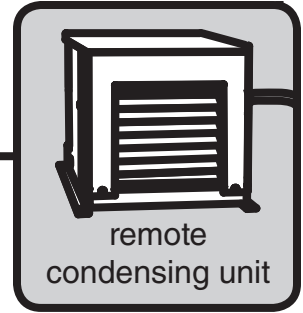

Drop-in Remote Condensing
 RIDE™ remote ice delivery
 equipment

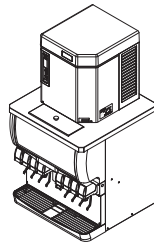

Harmony Remote Condensing
 Top Mount

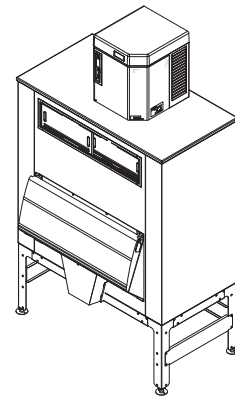

Bin Remote Condensing
 Top Mount

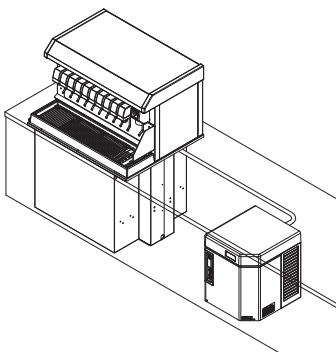

Vision™ Remote Condensing
 RIDE remote ice delivery equipment

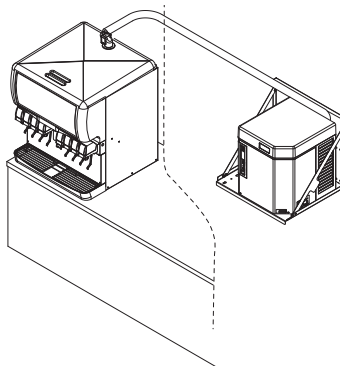

Harmony™ Remote Condensing
 RIDE remote ice delivery equipment

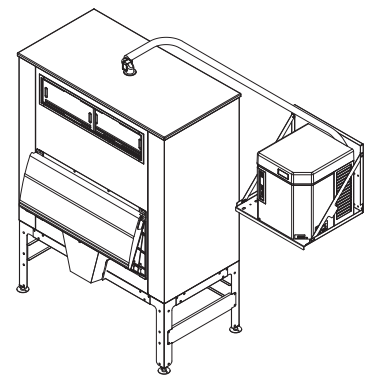

Bin Remote Condensing
 RIDE remote ice delivery equipment

Read and complete the following 8 installation steps

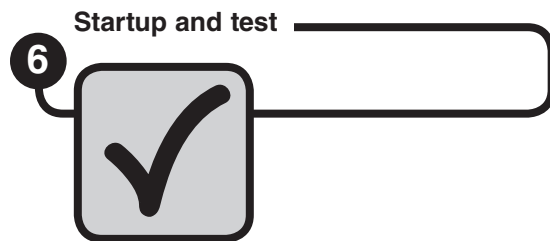
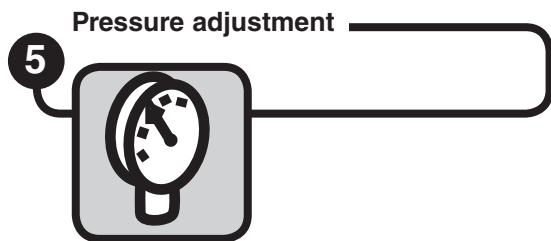
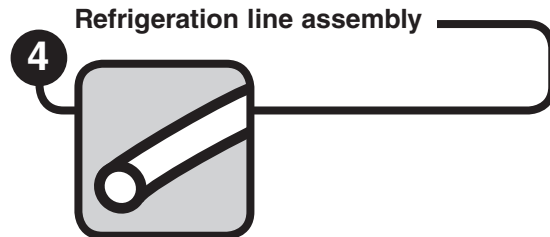
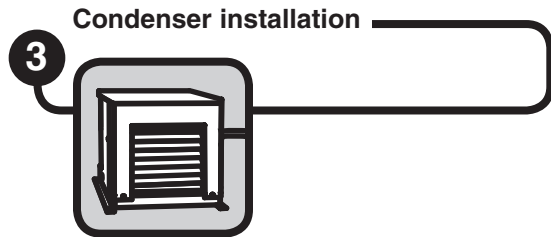
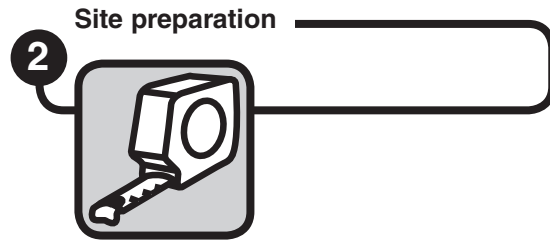
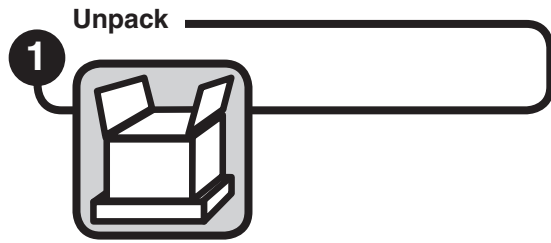

Chewblet® Ice Machine Model Number Configurations

HC C 1400 A V S

Icemaker	Voltage	Series	Condenser	Application	Configuration
MC Maestro™ Chewblet® (400 Series)	C 208-230/60/1 (icemaking head) <i>Self-contained only.</i>	400 up to 454 lbs (206kg)	A Air-cooled, self-contained W Water-cooled, self-contained	V Vision™	S RIDE™ <i>(RIDE remote ice delivery equipment)</i>
HC Horizon Chewblet (1000, 1400, 1650 Series)	D 115/60/1 (icemaking head) <i>Self-contained and remote. If remote unit, high side is 208-230/60/1.</i>	1000 up to 1036 lbs (471kg)	R Air-cooled, remote condensing unit N Air-cooled, no condensing unit for connection to parallel rack system	H Harmony™ B Ice storage bin J Drop-in M Ice Manager diverter valve system	T Top-mount
HM Horizon Micro Chewblet	E 230/50/1 (icemaking head) <i>Self-contained only.</i> F 115/60/1 (icemaking head) <i>Remote only. High side is 208-230/60/3.</i>	1400 up to 1450 lbs (658kg) 1650 up to 1580 lbs (717kg)			

Carefully unpack and inspect the contents of your condensing unit

Unpack

1



Site preparation

2

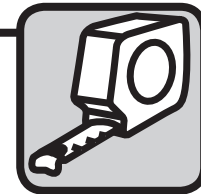

To ensure proper performance, ease of service and warranty coverage, it is critical that you follow the requirements detailed in this manual. If you cannot meet these requirements or have questions, call our technical service group at 877.612.5086 for installation support.

2.1 Condenser Unit Clearances

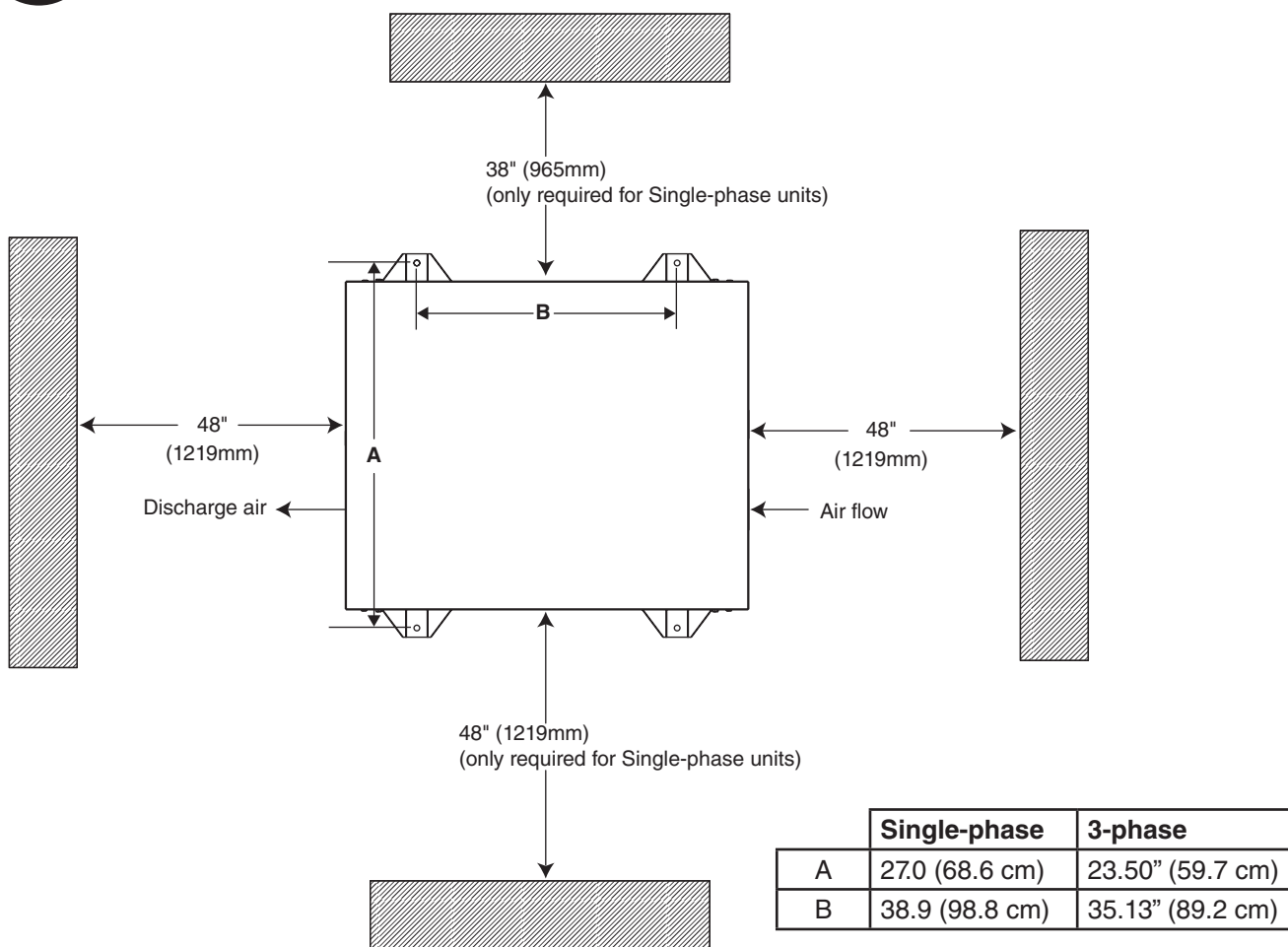

- Position condenser unit as shown above, with clearances noted above

2.2 Condenser installation specifications

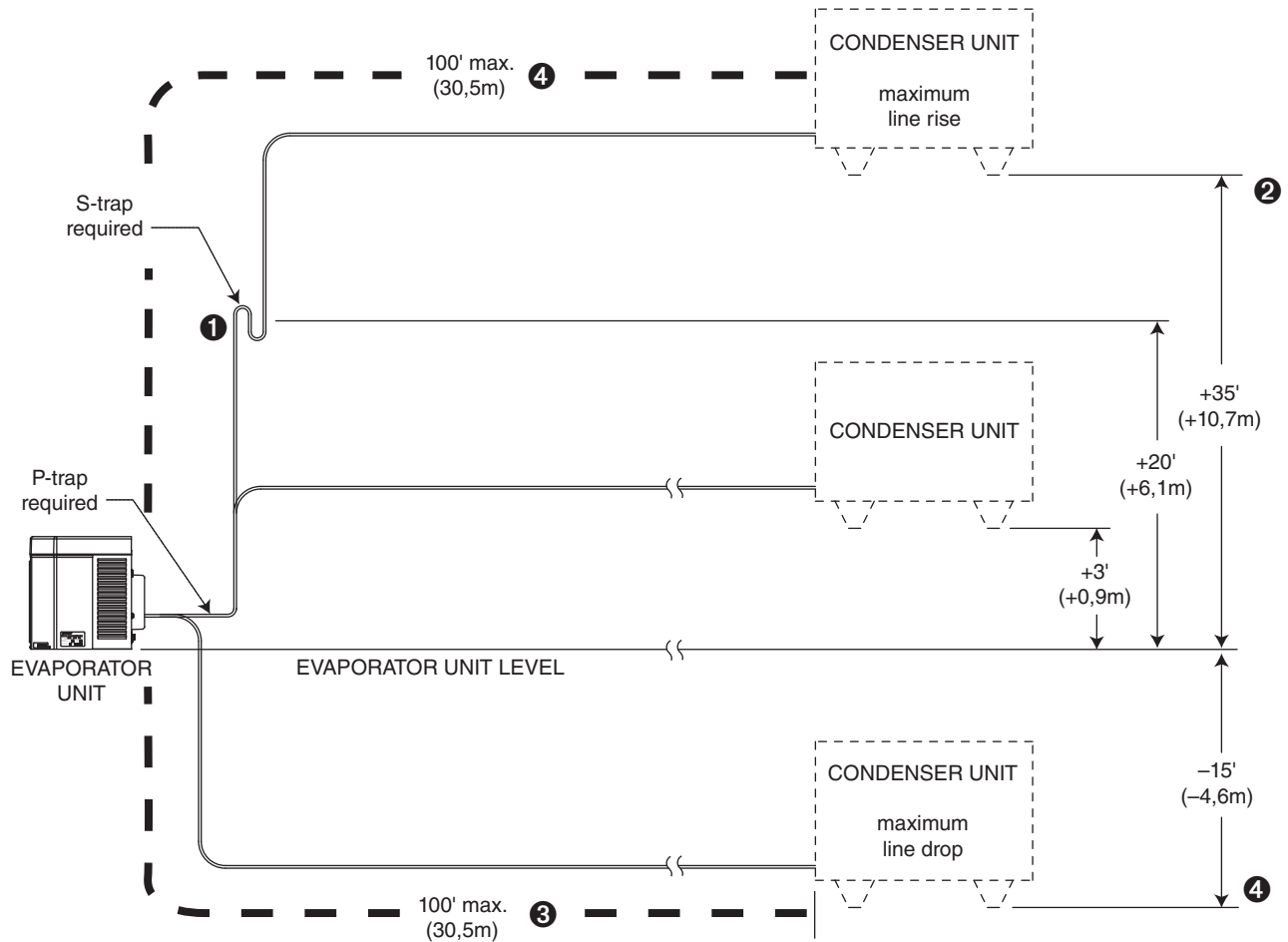

Site layout:

- Outdoor ambient temperature range: -20 F to 120 F (-29 C to 49 C)
- Installation with condenser unit elevations above 20' (6,1m) require an S-trap at the midpoint of the rise **1**
- Maximum line rise must not exceed 35' (10,7m) **2**
- Maximum line set length must not exceed 100' (30,5m) **3**
- Maximum line drop must not exceed 15' (4,6m) **4**

Note: The service loop is not included when calculating the length, rise or drop of the tubing run.

Note: 1400/1650 units only:

HCD1400/1650 condensing units contain a liquid to suction line heat exchanger. To maintain optimum liquid refrigerant sub-cooling from the heat exchanger, the entire liquid line should be insulated **separately** from the suction line.

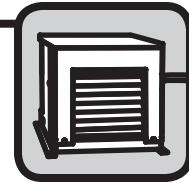

3.1 Install condensing unit

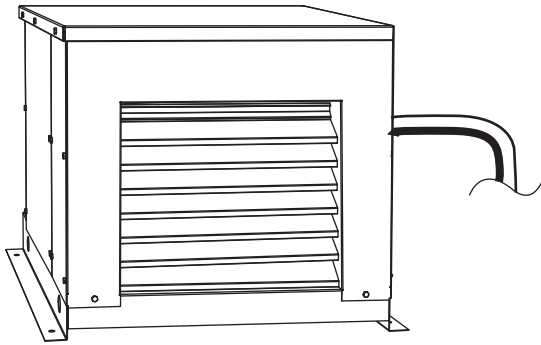

- Level unit
- Securely attach base of unit using holes found in base plate

3.2 Electrical connections

Horizon Remote Single-Phase

- 208-230/60/1
1000 - 15 amp circuit
1400 - 30 amp circuit
1650 - 50 amp circuit

Horizon Remote 3-Phase

- 208-230/60/3
1000 - 15 amp circuit
1400 - 25 amp circuit
1650 - 35 amp circuit

- Refer to wiring schematic located in condenser unit electrical box



CAUTION

- Electrical disconnects required within 10' (3m) for all hard wired connections
- Install in accordance with NEC and local electrical codes

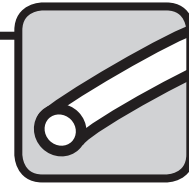

4.1

**Refrigeration line installation: 7/8" suction / 3/8" liquid line (1650)
5/8" suction / 3/8" liquid line (1000, 1400)**

⚠ CAUTION

- The installer of the refrigeration line set must be USA Government Environmental Protection Agency (EPA) certified in proper refrigeration handling and service procedures
- A qualified person must perform all roof or wall penetration
- Do not form unwanted traps in refrigeration lines. A service loop is not considered an oil trap.
- Never coil excess refrigeration tubing
- The compressor oil rapidly absorbs moisture. Minimize the exposure of the refrigeration system by not releasing the condenser unit or evaporator unit holding charge until all line connections are finished and the system is ready for evacuation.
- It is recommended that both liquid and suction lines are run and insulated together for the first 15 feet (4,6m) from the condensing unit. This protects the system from sub-cooling loss and/or liquid slugging the compressor.

⚠ WARNING

- This unit contains an R404A holding charge

1. Make and connect line set run from the condensing unit to the evaporator unit with all specifications found in the installation specifications section. Do not overheat shut off valves on the condenser unit or evaporator unit.
2. Leak check field joints via the evaporator unit service valves.
3. Evacuate line set via the evaporator unit service valves.
4. Determine required charge size based on the model and line length.

R404A Ice Machine Charge Specifications			
Line Run	Charge 1000R	Charge 1400R	Charge 1650R
0 - 50 ft (0 - 15,2m)	8 lbs (4,9kg)	11 lbs (4,9kg)	11 lbs (4,9kg)
50 - 75 ft (15,2 - 22,9m)	9 lbs (5,4kg)	12 lbs (5,4kg)	12 lbs (5,4kg)
75 - 100 ft (22,9 - 30,5m)	10 lbs (5,9kg)	13 lbs (5,9kg)	13 lbs (5,9kg)
100 ft + (30,5m+)	not recommended – consult factory		

5. Open the liquid line service valve and suction line service valve on the evaporator unit and condenser unit.
6. Open the liquid line valve on the receiver, then the suction line valve on the compressor unit.
7. Liquid charge unit through liquid line shut off valve on the evaporator unit or receiver valve on the condensing unit.
8. Isolate the refrigerant tank from high pressure side on the system.
9. Turn on power to condensing unit and evaporator unit.
10. Complete system charge through low pressure side.
11. Insulate entire suction line including shut off valves to prevent condensation.

Pressure adjustment

5



5.1 Check pressure adjustment

1. The pressure control is located in the electrical box near the refrigeration line set connection point.
2. Verify the control is set for system operation of 10 psi cut out and 30 psi cut in
3. If adjustment is needed always adjust the cut in first.

Start up and test

6



NOTICE

Ice machine MUST be cleaned and sanitized prior to operation!

Consult Operation and Service Manual provided with ice machine for cleaning and sanitizing instructions.

6.1 Verify operation

- Turn dispenser power ON if applicable
- Check current draw of compressor to verify correct electrical operation
- Put a piece of ice on bin thermostat or hold a cup under the shuttle actuator on the bin/dispenser to verify that the evaporator unit shuts OFF; condensing unit pumps down and shuts off.
- After shut off, restart the ice machine

Horizon Condenser Unit Compressor Amperage		
Single-Phase		
Model Number	Compressor	Running amps (+/- 10%)
1000R 00168054	AJA7490ZXD	7.4
1400R 00178640	AWA9517ZXN	14.7
1650R 00973925	AVA9522ZXN	22.6
3-Phase		
Model Number	Compressor	Running amps (+/- 10%)
1000R 00990200	AWA9490ZXTHN	4.7
1400R 00990218	AWA9517ZXTHN	7.3
1650R 00990226	AVA9522ZXTHN	10.3

Harmony, Horizon, Ice Manager, RIDE, and Vision are trademarks of Follett Corporation.
Chewblet and Follett are registered trademarks of Follett Corporation, registered in US.



801 Church Lane • Easton, PA 18040, USA
Toll free (877) 612-5086 • +1 (610) 252-7301
www.follettice.com



00160002R09
4/12