

1. SAFETY INSTRUCTION

The Alpha 608 is relatively simple to use, however, it is very important to observe the proper safety procedures before, during, and after operation. When used properly, the Alpha 608 will enhance safety, productivity and efficiency in the workplace.

The following procedures should be strictly followed:

1. Do not change the IDs on transmitter encoder and receiver decoder boards at will.
2. Check the transmitter casing and pushbuttons daily. Should any damage that could inhibit the proper operation of the transmitter be found the unit should be immediately removed from service.
3. Check the transmitter voltage whenever it is operated.
4. The red emergency stop button (EMS) should be checked at the beginning of each shift to ensure it is in proper working order and the "Stop" command is being received by the receiver.
5. In the event of an emergency press down the EMS button will immediately deactivates the receiver MAIN relay and the transmitter power. Then turned the power "off" from the main power source to the crane or equipment.
6. Do not use the same RF channel and ID code as any other system in use at the same facility or within 300-meter distance.
7. Ensure the waist belt is worn at all time during operation to avoid accidental damage to the transmitter.
8. Never operate a crane or equipment with two transmitters at the same time with the same RF channel and ID code, as it will cause radio interference.

FCC 15.21: "Changes or modifications are not expressly approved by the manufacturer could void the user's authority to operate the equipment."

"Operations is subject to the following two conditions: (1) this device may cause interference, and (2) this device must accept any interference, including interference that may cause undesired operation of the device."

2. PUSHBUTTON CONFIGURATION

2.1 Alpha 607 & 608 Models

- α* 607A -- (7) single speed pushbuttons
- α* 607B -- (6) double speed pushbuttons + (1) single speed pushbutton
- α* 607AT -- (6) single speed pushbuttons + (1) single speed pushbutton + (1) selector pushbutton
- α* 607BT -- (6) double speed pushbuttons + (1) single speed pushbutton + (1) selector pushbutton
- α* 608A -- (8) single speed pushbuttons
- α* 608B -- (6) double speed pushbuttons + (2) single speed pushbuttons

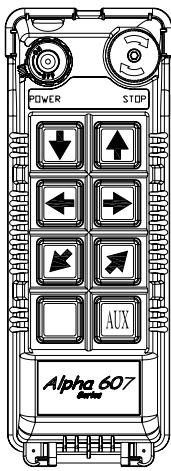

(Alpha 607A)

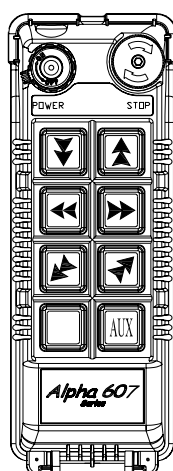

(Alpha 607B)

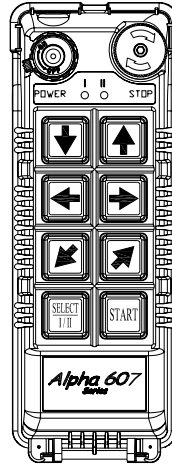

(Alpha 607AT)

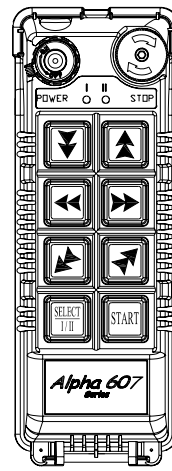

(Alpha 607BT)

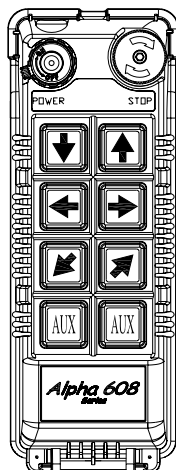

(Alpha 608A)

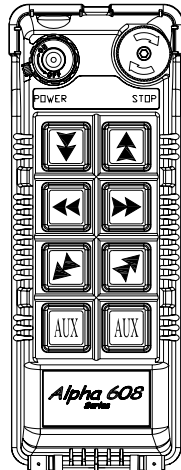

(Alpha 608B)

3. TRANSMITTER OUTLINE

3.1 TRANSMITTER OUTLINE

Size : 189mm X 68mm X 30mm

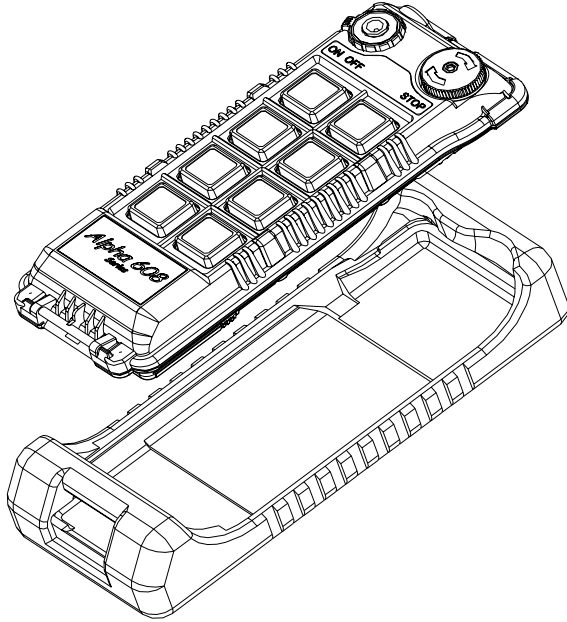

(Fig.1) Transmitter Outline

3.2 TRANSMITTER INTERNAL ASSEMBLY

- (1) Internal antenna
- (2) Status LED display
- (3) Battery contact
- (4) AUX micro-button connector*
- (5) Programming port
- (6) ID code dip-switch
- (7) JP2 setting pin
- (8) JP1 setting pin

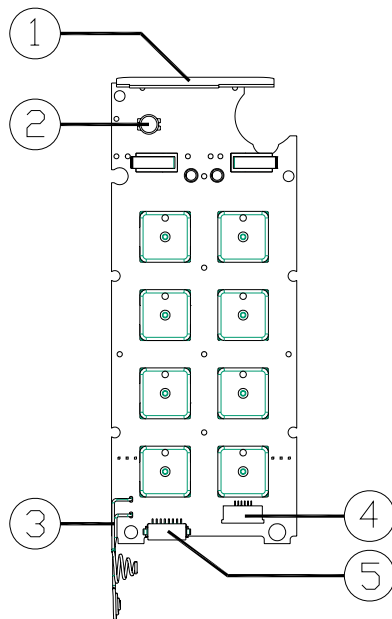

(Fig.2) Front View

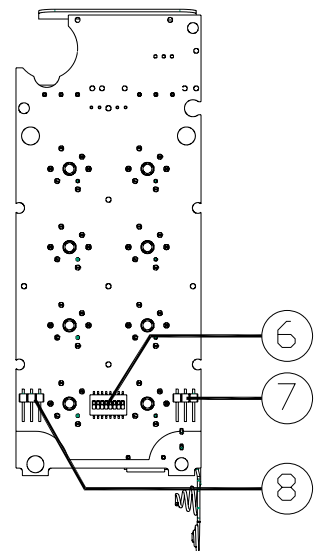

(Fig.3) Back View

3.3 TX INTERNAL MODULE – encoder board

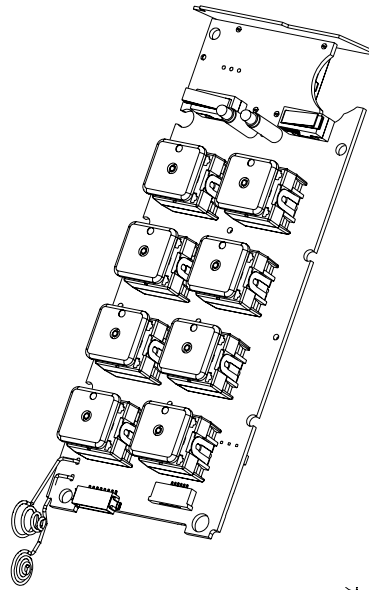

(Fig.4) Encoder board

3.4 Transmitter shoulder strap

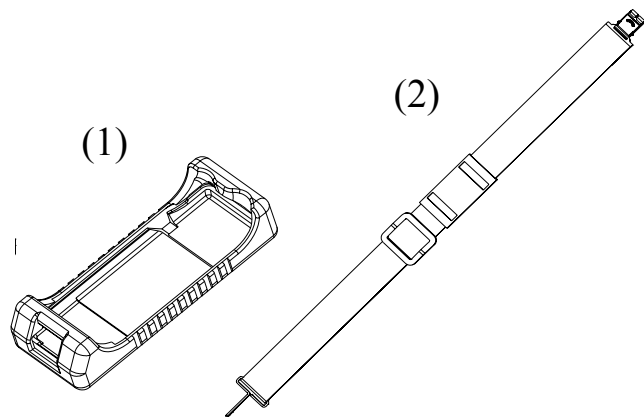

(1) Shock-absorbing rubber

(2) Shoulder strap

4. RECEIVER OUTLINE

4.1 External Assembly

SIZE : 300mm X 230mm X 86mm

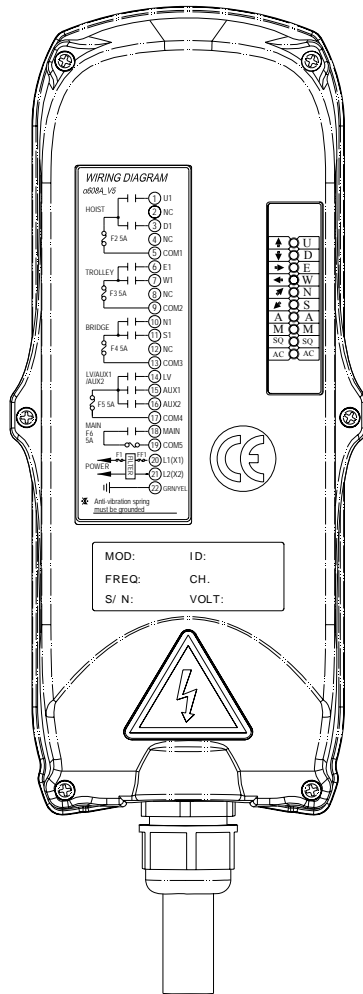

(Fig.7) Front View

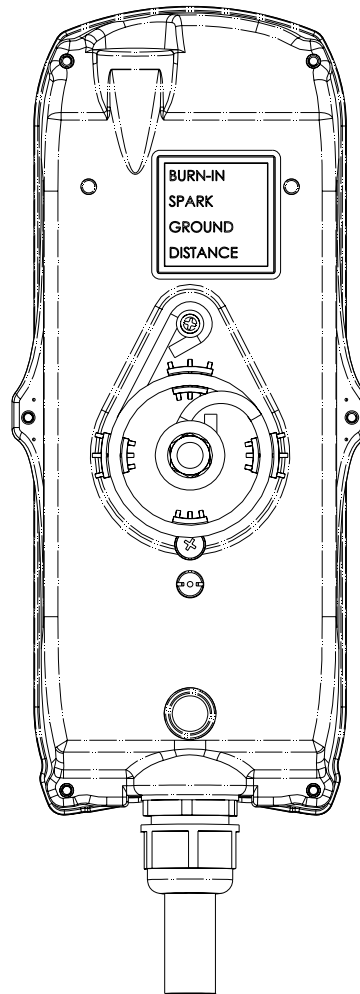

(Fig.8) Back View

4.2 Internal Assembly

(Fig. 9) Internal Parts Assembly

- 1) Receiving RF module
- 2) External programming port
- 3) Secondary power AC fuse (0.50A)
- 4) Contact output seat (CN8)
- 5) Primary power AC fuse (1.0A)
- 6) AC power input seat (CN2)
- 7) Internal Antenna
- 8) System Status LED display*
- 9) External antenna port
- 10) ID code dip-switch
- 11) RF channel dip-switch
- 12) Contact relay LED display
- 13) Pushbutton #1 and #2 fuse (5.0A)
- 14) Contact output seat (CN3)
- 15) MAIN contact fuse (5.0A)
- 16) Pushbutton #3 and #4 fuse (5.0A)
- 17) Pushbutton #5 and #6 fuse (5.0A)
- 18) Contact output seat (CN4)
- 19) LV & AUX fuse (5.0A)
- 20) Cable gland & output cable

* Please refer to page 27 for system status LED display information.

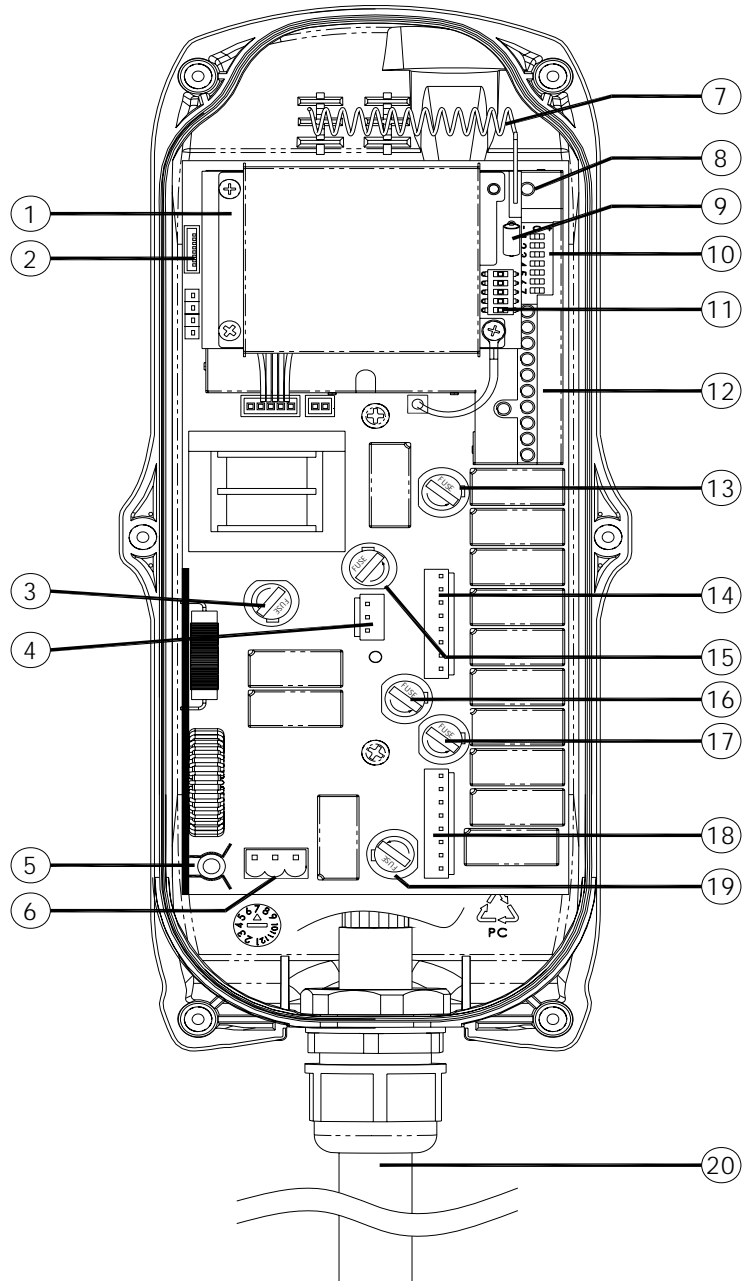

5. OUTPUT CONTACT DIAGRAMS

5.1 Alpha 607 Models

Alpha 607A

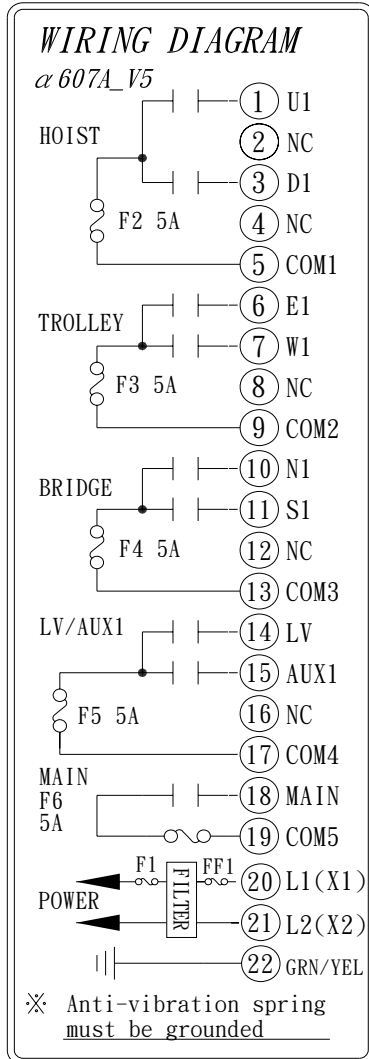

Alpha 607B

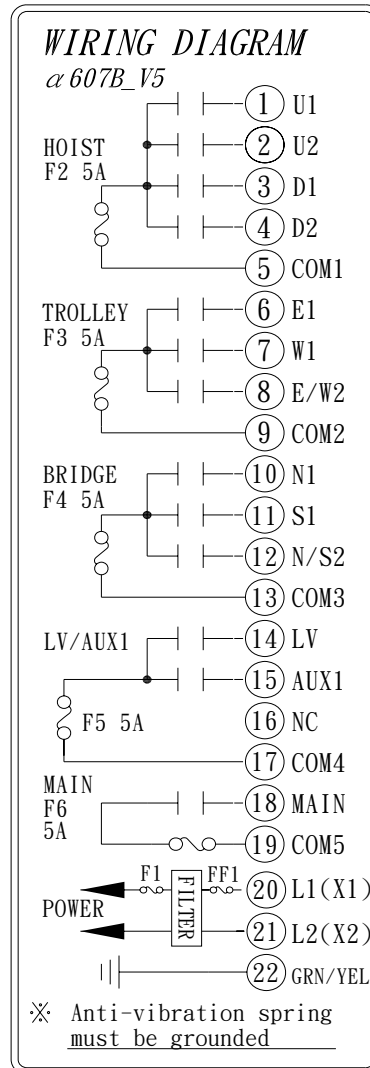

Alpha 607AT

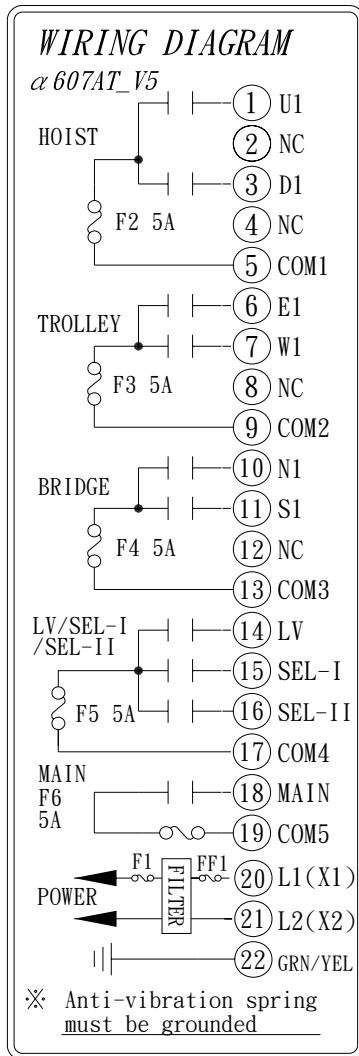

Alpha 607BT

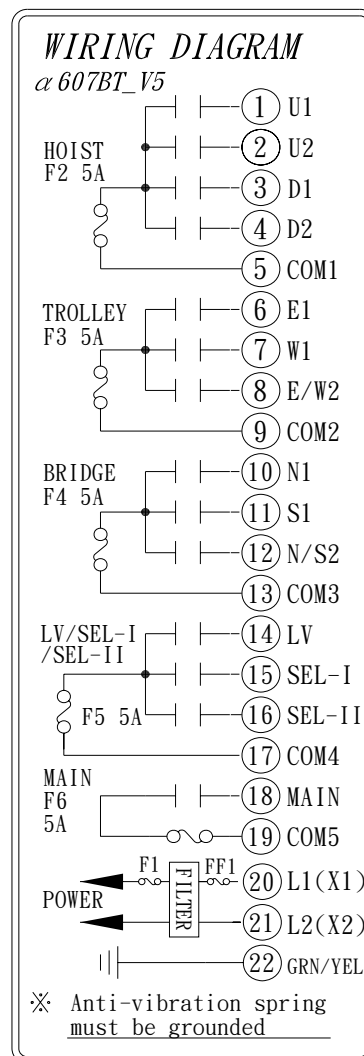

5.2 Alpha 608 Models

Alpha 608A

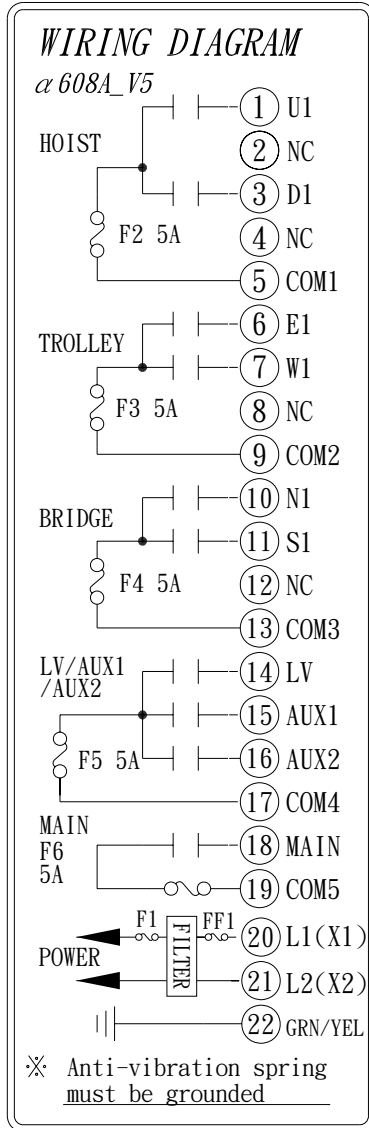

Alpha 608B

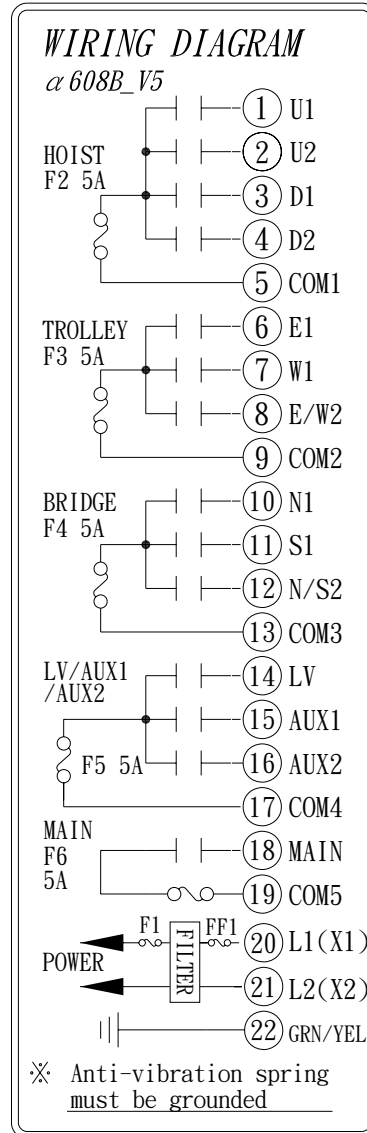

6. TRANSMITTER SETTINGS

6.1 How to Set ID Codes

6.1.1 Set by programming tool

6.1.2 Set by encoder board JP1, 1st / 2nd pin and dip-switch

Setting Steps:

- (1) Rotate the transmitter power to OFF position
- (2) Disassemble shock-absorbing rubber
- (3) Put the transmitter pushbutton downward and disassemble transmitter bottom casing.
- (4) Set ID code with dip-switch and put short boot on 1st / 2nd pin of JP1.
- (5) Make sure the batteries are installed properly.
- (6) Rotate the transmitter power switch to ON position.
- (7) Green status LED ON for 0.1 sec, OFF for 0.1 sec, flash for 1 sec. (5 times)
- (8) Green status LED steady ON indicates the setting is completed. If the LED status light is changed to red, the setting is failed. Please repeat the above setting steps until the setting is successful.
- (9) After setting is completed and successful, remove short boot on 1, 2 pin of JP1.
- (10) Rotate transmitter power switch to OFF position.

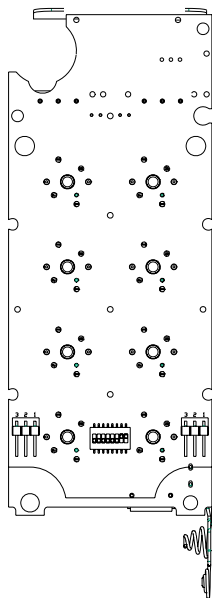

(Fig. 10) Back view

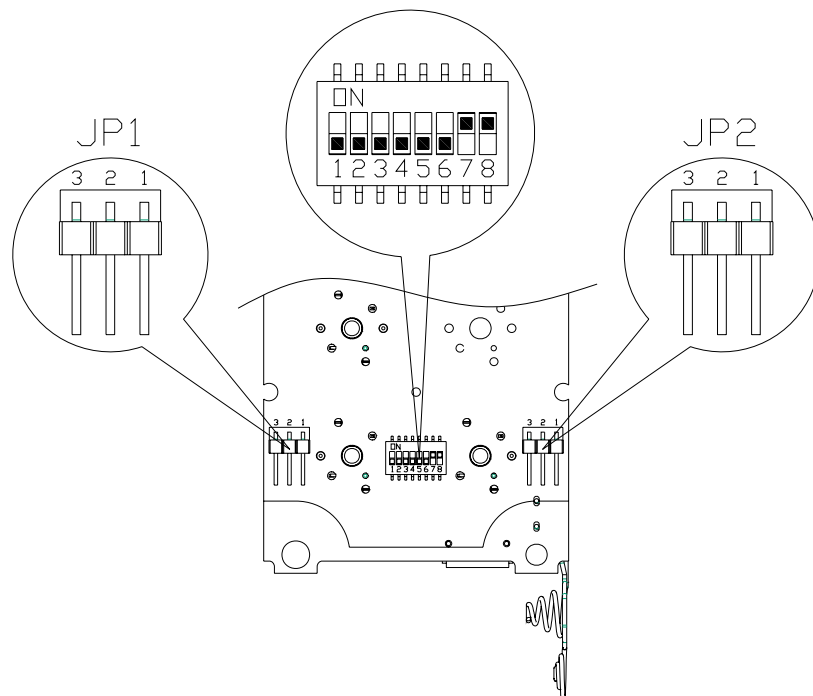

(Fig. 11) Position of dip-switch & jumpers

Top slot ON → “1”; bottom slot → “0”. The setting above is 00000011.

6.2 Transmitter Channel Settings

Transmitter channel setting (select the channel you would like to operate. No exceed to channel limit)

6.2.1 Set by programming tool

6.2.2 Set by encoder board 2nd & 3rd pin of JP1 and dip-switch

When setting frequency on TX board JP1, put short boot on 2nd & 3rd pin of JP1. Change the frequency needed by changing the dip-switch setting. Repeat the previous steps to set frequency. (Note: set the dip-switch from the 4th digit)

Example : Set channel as 03→(00011) → Correct setting

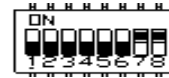

7. RECEIVER SETTINGS

7.1 How to Set Receiver ID Codes

Top slot → “1”

Bottom slot → “0”

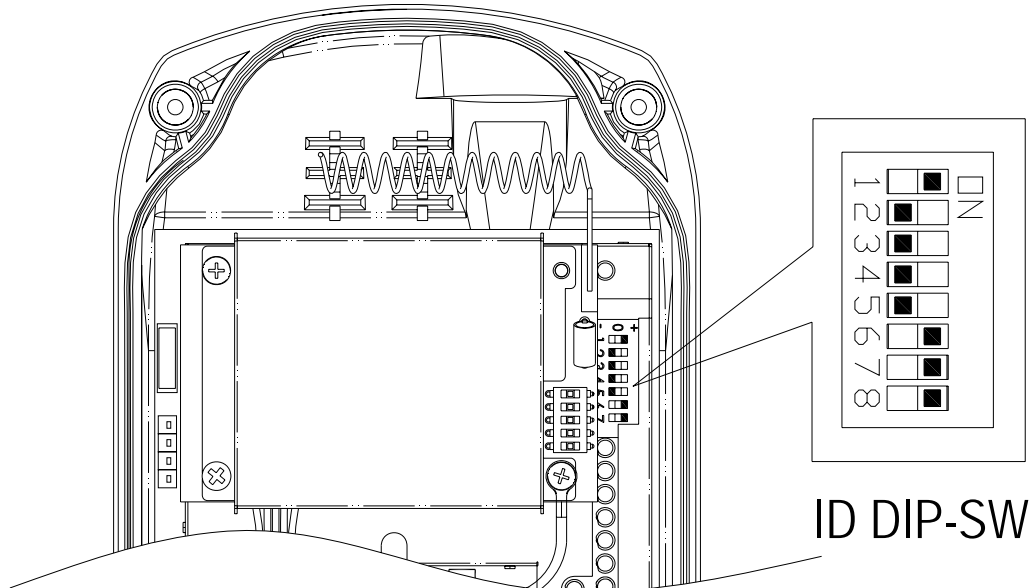

Set the ID codes needed on the decoder board dip-switch. For example: the ID codes set above → 10000111.

7.2 Receiver RF Channel Setting

There are 20 sets of user-adjustable receiving RF channels that can be set manually via a 5-position dip-switch located to the right of the receiving RF module. Change the receiving RF channel simply by resetting these 5-position dip-switch. For the location of the receiving RF module, please refer to fig. 15, 16, and 18 on page 11, 12, and 14.

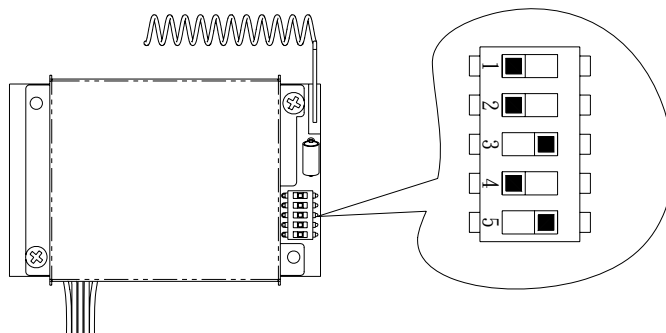

Top slot → “1” ; bottom slot → “0”

For example : the channel dip-switch set above → 00101, channel 05.

7.3 Receiver Function Setting

7.3.1 Set by programming tool

7.3.2 Adjust Jumper setting function by decoder board

α 608 function can be changed simply by adjusting Jumper setting. Please refer to Jumper Set Table as below.

Receiver function setting:

- A. Select any pushbutton or ON/OFF power switch to start the system. The MAIN relay will be activated when system is started. (after the receiver power is started and emergency stop button is elevated)
- B. The MAIN relay auto shutdown time can be set as 3 minutes or depends on customer's single request. (Remark 1)
- C. When transmitter voltage is low, relays for the receiver MAIN and LV (Remark 1) will be auto shutdown after one minute.

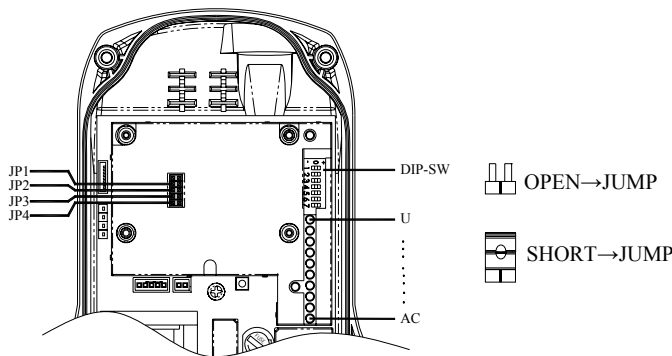

(Fig. 12) Alpha 607, 608 models

Jumper Set table: in-plant setting (default).

JP1	Open	Power key to activate relay MAIN relay (After turning "on" the transmitter power and pressing the emergency Stop button)
JP2	Open	No auto shutdown time on Main relay
	Short	The receiver MAIN will be deactivated after consecutive 5 minutes of standby time.
JP3	Open	No auto shutdown time on MAIN and LV relays
	Short	After one minute of transmitter LV, the MAIN and LV relays will be deactivated.
JP4	Open	7 th AUX: "Normal" pushbutton setting
	Short	7 th AUX: "Toggle" pushbutton setting

※ Open → no Jumper

Short → put Jumper

Remark 1 : The setting of auto shutdown time can be done by manufacturer or distributor. Setting range: 0~30 minutes. (In-plant setting: 3 minutes)

Remark 2 : When the transmitter voltage is low, LV relay will be activated and siren or lights will be ON. (one second of interval)

7.4 Frequency (RF) Channels Table

Band 433MHz	Dip-Switch Setting	Channel
433.075 MHz	00000001	01
433.100 MHz	00000010	02
433.125 MHz	00000011	03
433.150 MHz	00000100	04
433.175 MHz	00000101	05
433.200 MHz	00000110	06
433.225 MHz	00000111	07
433.250 MHz	00001000	08
433.275 MHz	00001001	09
433.300 MHz	00001010	10
433.825 MHz	00001011	11
433.850 MHz	00001100	12
433.875 MHz	00001101	13
433.900 MHz	00001110	14
433.925 MHz	00001111	15
433.950 MHz	00010000	16
433.975 MHz	00010001	17
434.000 MHz	00010010	18
434.025 MHz	00010011	19
434.050 MHz	00010100	20
434.075 MHz	00010101	21
434.100 MHz	00010110	22
434.125 MHz	00010111	23
434.150 MHz	00011000	24
434.175 MHz	00011001	25
434.200 MHz	00011010	26
434.225 MHz	00011011	27
434.250 MHz	00011100	28
434.275 MHz	00011101	29
434.300 MHz	00011110	30

8. TRANSMITTER OPERATION & STATUS

LIGHT

8.1 Transmitter Operating Steps

1. Make sure the two “AA” NiMH rechargeable batteries are installed correctly. Please note the polarity of the batteries.
2. **Status lights**_ To operate the transmitter, please rotate the power key on the top-left corner clockwise to “on” position. The status LED (green and red) will be steady “on” for 2 seconds and then “off”. If the transmitter Status LED displays a red blinking light that is “on” → 0.1 second and “off” → 1.9 seconds, or no light at all, this indicates the transmitter with batteries needs to be recharged. For battery charging or replacement, please refer to instruction next page.

When any function pushbutton is depressed, the transmitter Status LED displays a red blinking light that is “on”→ 0.1 second and “off”→ 1.9 seconds. If the voltage is low, the transmitter Status LED will be “on”→0.1 second and “off”→1.9 seconds, this indicates the transmitter with batteries needs to be recharged. Continuous operation will cause the transmitter battery power exhausting and cannot operate at all.

3. **EMS & Restarting** _ In case of an emergency, press down the red emergency stop button (EMS) will immediately deactivates the transmitter and receiver MAIN relay. The transmitter Status LED will be blinking “on”→0.5 second and “off”→0.5 second for 30 seconds (Mode 0). Then turn off the transmitter power.
4. The emergency stop button is a right-rotate momentary spring-return type. To turn on the transmitter and activate the MAIN relay, please elevate the emergency stop button again and rotate the transmitter power key to “ON” position.
5. Note that the transmitter cannot be hit by outer forces, so that malfunction can be prevented.
6. The operating temperature is -10 ~ +50°C . Avoid operating the transmitter in high temperature workshop. If operating temperature is higher than 50°C ,the auto shutdown protection installed inside CPU will shut down the transmitter and deactivate the MAIN relay.
7. To operation normally, the battery power has to be over 2.2V. If the voltage is lower than 2.2V, the system cannot be started and low voltage will be showed until the MAIN is completely shutdown.
8. If the power voltage is lowered than 2.2V when transmitter is operated, the LV code will be “1” and low voltage status light will be shown. The transmitter will stop sending signals when voltage is lower than 2.0V.

Power status
light

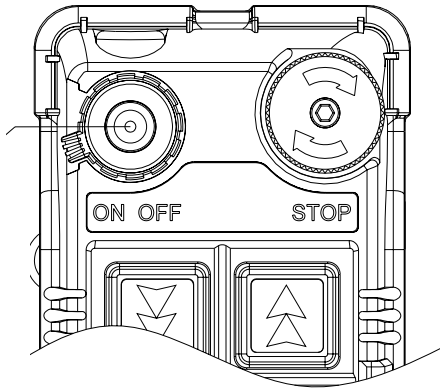

STOP: press → lock (emergency stop)

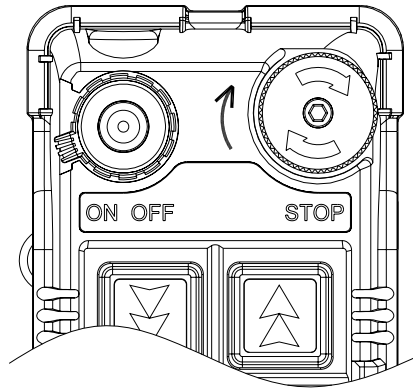

STOP: Elevate clockwise → reset (Turn on the transmitter at any time)

8.2 Transmitter Status Light

Type	Status	Solution	LED Indication
2	Power on when voltage is low	BATT<2.2V	Red light flash ON_0.1/OFF_1.9 sec (until power_off)
3	Setting failed or invalidated	Set data by using JUMPER & dip-switch without following rules	Red light ON_0.1/OFF_0.1 sec
4	Setting completed	JP1 or JP2 inserted	Green light ON until power_off.
5	EEPROM ID error	EEPROM ID code does not match CPU	Red light ON until power_off
6	RF module abnormal	PLL UNLOCK	Red light ON_0.1/OFF_0.1 sec
7	ID even number error	Setting error	Red light ON_1/OFF_1 sec
8	Pushbutton locked	power_on pushbutton connected	Red light ON_1.9/OFF_0.1 sec (until power_off)
9	Normal power_on	BATT>=2.2V and all the pushbuttons are not depressed	All the lights ON_2 sec
10	STOP status	STOP button is pressed	MODE 0: Red light ON_0.5/ OFF_0.5sec, flash 30sec. MODE 1: all the lights OFF
11	Low voltage during operation	BATT<2.2V and press pushbutton	Red light flash ON_0.1/OFF_1.9sec
12	Normal operation	Press pushbutton	Green light flash ON_0.1/OFF_1.9 sec

9. RECEIVER INSTALLATION

9.1 Preparation for Installation

1. Required Tools for Receiver Installation:
 - (1) Flat Head Screwdriver (-)
 - (2) Phillips Head Screwdriver (+)
 - (3) Multi-Meter
 - (4) 14mm Wrench x 2
 - (5) Power Drill with φ 10.5mm Drill-Bit
2. Check to ensure that your receiver is not set to the same RF channel and ID code as any other systems in operation at the same facility or within 300-meter distance.
3. Prior to installation, make sure that the crane or equipment itself is working properly.
4. Use a multi-meter to check the voltage source available and ensure the receiver voltage setting matches your power source.
5. Prior to installation, switch off the main power source to the crane or equipment.

9.2 Step By Step Installation

1. For better reception, the location selected should have the antenna visible from all areas where the transmitter is to be used.
2. The location selected should not be exposed to high levels of electrical noise. Mounting the receiver next to an unshielded variable frequency control (inverter) may cause minor interference. Always locate the receiver unit as far away from inverter controls as possible.
3. Ensure the selected location has adequate space to accommodate the receiver enclosure.
4. Make sure the receiver unit is in upright position (vertical).
5. The distance between the antenna and the control panel should be as far apart as possible (refer to the figure on page 22).
6. If a crane or equipment's runway is longer than 100 meters, an external antenna should be added. The Alpha 608 receiver housing has provisions for an external factory installed antenna available as an option, contact your dealer for price and delivery.
7. Drill a hole on the control panel (10.5mm).
8. Tightened the bolt nuts provided.
- 9. If the control panel has a plastic surface, extended grounding wire should be used.**
10. For system wiring, please refer to the output contact diagrams from page 4.
11. Ensure all wiring is correct and safely secured and all screws are fastened.

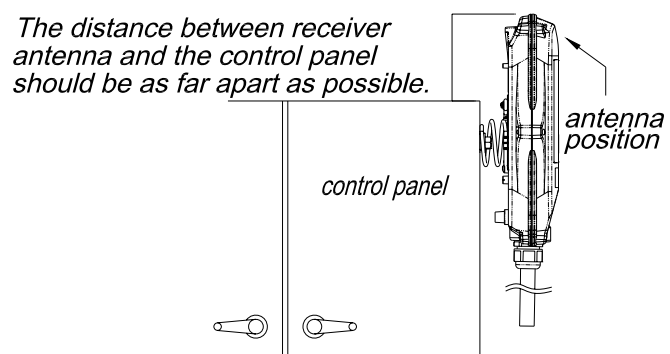

(Fig. 13) Alpha 607, 608 models

9.4 Receiver system Status LED Display

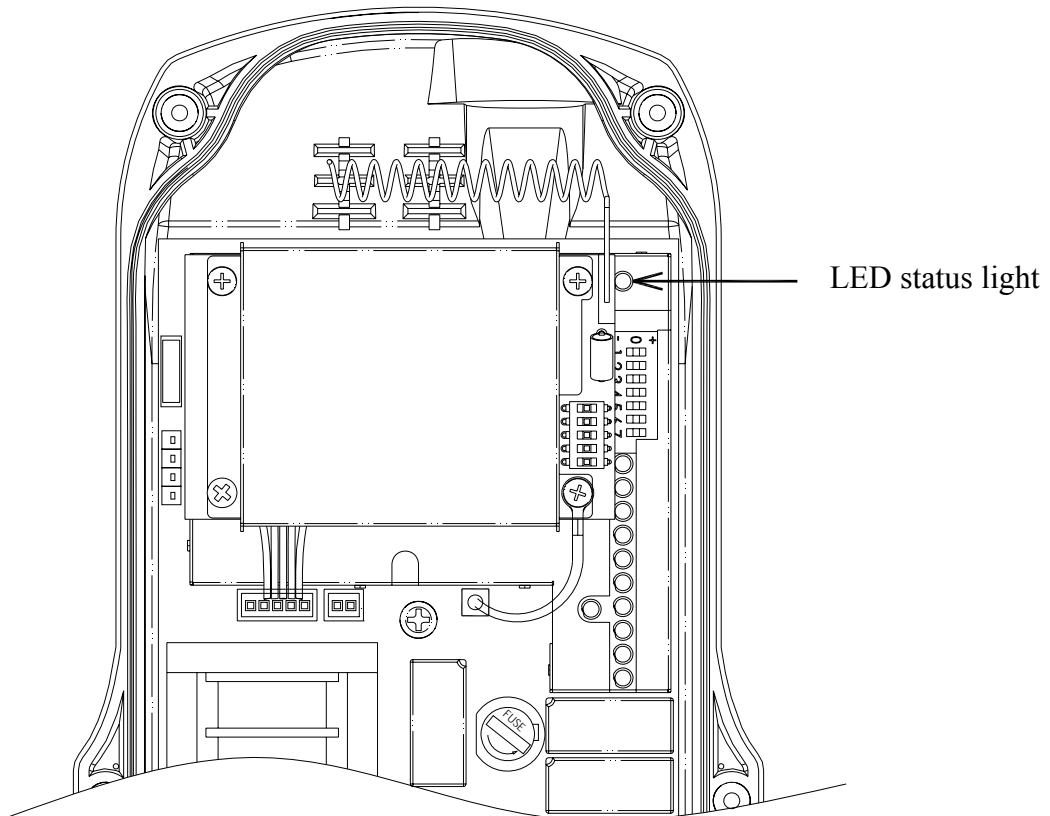

Receiver system Status LED Display

TYPE	LED INDICATION	PROBLEM AND SOLUTION
1	Constant red light.	EEPROM error – reprogramming required.
		Incorrect receiver ID code setting (see note below).
2	ON → 1.0 second OFF → 1.0 second	ID code not matched on both the transmitter and receiver unit, please readjust accordingly.
3	Dim or no light.	Under-voltage, check the main power-supply.
4	ON → 2.0 seconds OFF → 0.1 second	MAIN contact relay jammed or defective.
5	ON → 0.1 second OFF → 2.0 seconds	System normal with transmitter pushbutton either in neutral or in transmitter power “off” position.
6	ON → 0.1 second OFF → 0.1second	System normal with transmitter pushbutton in non-neutral position (pushbutton depressed).

Note: Please refer to section 7.2 on page 22 for correct ID code setting.

11. TROUBLE SHOOTING

Should the operator find the equipment not operating normally, please check the chart below for simple trouble shooting tips.

PROBLEM	POSSIBLE REASON	SOLUTION
Transmitter does not communicate with the receiver.	Transmitter and the receiver are not on the same RF channel (SQ lamp not lit) or ID code.	Ensure the correct transmitter is in use. The labels on the receiver and the transmitter will identify the RF channel and ID code in use.
Transmitter does not communicate with the receiver.	Low or no transmitting power from the transmitter unit.	Turn "on" the transmitter with EMS elevated. If the status LED shows blinking red light or no light at all, then turn the power "off" and replace the two alkaline "AA" batteries.
No power to the receiver (AC power indicator on the receiver unit not lit).	Blown fuse or no input power connection.	Ensure power input to the receiver unit is correct. If the power indicator (AC) is still not lit, please check the receiver for any open fuse.
Outputs do not operate correctly.	Receiver configuration is not set properly or output wiring is incorrect.	Please refer to section 6 and 7 to ensure receiver is correctly wired and configured for your application.
Transmitter does not communicate with the receiver.	Transmitter is turned on with the EMS activated (pressed down).	Elevate the EMS first and then turn the power switch off and then on again.

12. **SYSTEM SPECIFICATION**

Transmitter Unit

Frequency Range	:	433 MHz
Transmitting Range	:	100 meters
Hamming Distance	:	6
Channel Spacing	:	25KHz
Frequency Control	:	Quartz Crystals
Frequency Drift	:	< 5ppm @ -25°C ~ +75°C
Frequency Deviation	:	< 1ppm @ 25°C
Spurious Emission	:	- 50dB
Transmitting Power	:	~1mW
Emission	:	F1D
Antenna Impedance	:	50 ohms
Enclosure Rating	:	IP-66
Source Voltage	:	3.0V (“AA” alkaline batteries x 2)
Current Drain	:	10 ~ 18mA
Operating Temperature	:	-25°C ~ +75°C
Dimension (607~608 Models)	:	172mm x 68mm x 33mm
Weight (607~608 Models)	:	285g (include batteries)

Receiver Unit

Frequency Range	:	433 MHz
Channel Spacing	:	25KHz
Hamming Distance	:	6
Frequency Control	:	Synthesizer (PLL)
Frequency Drift	:	< 5ppm @ -25°C ~ +75°C
Frequency Deviation	:	< 1ppm @ 25°C
Sensitivity	:	-120dBm
Antenna Impedance	:	50ohms
Data Decoder Reference	:	Quartz Crystals
Responding Time	:	40ms (Normal)
Enclosure Rating	:	IP-65 (Alpha 500~560 Models) IP-66 (Alpha 580 Models)
Source Voltage	:	AC 220V ~ 230V @ 50/60 Hz.
Power Consumption	:	11VA
Operating Temperature	:	-25°C ~ +75°C
Output Contact Rating	:	250V @ 10A
Dimension (607~608 Models)	:	310mm x 134mm x 72mm
Weight (607~608 Models)	:	1,625g (include output cable)