

TABLE OF CONTENTS

	Page
1. SAFETY INSTRUCTION	2
2. PUSHBUTTON CONFIGURATION	
2.1 Alpha 607 & 608 Models	3
2.2 Alpha 612 Models	4
3. TRANSMITTER OUTLINE	
3.1.1 Alpha 607 & 608 Models	5-6
3.1.2 Alpha 612 Models	6-7
3.2 Alpha 607/608/612 Spare Parts	8
4. RECEIVER OUTLINE	
4.1 Alpha 607 & 608 Models Internal Assembly	8-9
4.2 Alpha 612 Models Internal Assembly	10-11
5. OUTPUT CONTACT DIAGRAMS	
5.2 Alpha 607 Models	12-13
5.3 Alpha 608 Models	14
5.4 Alpha 612 Models	15-19
6. SYSTEM CONFIGURATIONS	
6.1 How to Set ID Codes	22
6.2 Transmitter RF Channel Setting	23
7. RECEIVER SETTING	
7.1 How to Set Receiver ID Codes	24
7.2 Receiver RF Channel Setting	25
7.3 Receiver Function Setting	25
7.4 Frequency (RF) Channels Table	29
8. TRANSMITTER OPERATION & STATUS LIGHT	
8.1 Transmitter Operating Steps	31
8.2 Transmitter Status light	32
9. RECEIVER INSTALLATION	
9.1 Preparation For Installation	33
9.2 Step-By-Step Installation	33
9.3 System Testing	34
9.4 Receiver System Status LED Display.....	35
10. TROUBLE SHOOTING.....	37
11. SYSTEM SPECIFICATION	38
12. PARTS LIST	39

1. SAFETY INSTRUCTION

The Alpha 600 series are relatively simple to use, however, it is very important to observe the proper safety procedures before, during, and after operation. When used properly, the Alpha 600 series will enhance safety, productivity and efficiency in the workplace.

The following procedures should be strictly followed:

1. The transmitter is equipped with a specialized battery charger. Only two "AA" Ni-MH rechargeable batteries are allowed to be used in the transmitter. Please note the polarity of the batteries. Do not use other types of battery to prevent any accident
2. Do not change the IDs on transmitter encoder and receiver decoder boards at will.
3. Check the transmitter casing and pushbuttons daily. Should any damage that could inhibit the proper operation of the transmitter be found the unit should be immediately removed from service.
4. The red emergency stop button (EMS) should be checked at the beginning of each shift to ensure it is in proper working order and the "Stop" command is being received by the receiver.
5. In the event of an emergency press down the EMS button will immediately deactivates the receiver MAIN relay and the transmitter power. Then turned the power "off" from the main power source to the crane or equipment.
6. Do not use the same RF channel and ID code as any other system in use at the same facility or within 300-meter distance.
7. Ensure the waist belt is worn at all time during operation to avoid accidental damage to the transmitter.
8. Rotate the power switch to OFF position when the transmitter is not operated temporarily or the operation is finished.
9. Any repair or adjustment should be proceeding by repair technician for radio remote controls.
10. The operator should not change any electrical parts at will.

Changes or modifications are not expressly approved by the manufacturer could void the user's authority to operate the equipment.

This device complies with EMC Directive 89/336/EEC, Low Voltage Directive 76/23/EEC and R&TTE Directive 1995/5/EEC. This product has been approved for upper directives and covers the following countries : Austria, Belgium, Cyprus, Czech Republic, Denmark, Estonia, Finland, France, Germany, Greece, Hungary, Ireland, Italy, Latvia, Lithuania, Luxembourg, Malta, Poland, Portugal, Slovakia, Slovenia, Spain, Sweden, The Netherlands, UK, Iceland, Norway, Switzerland, Turkey & Romania.

2. PUSHBUTTON CONFIGURATION

2.1 Alpha 607 & 608 Models

1. α 607A -- (7) single speed pushbuttons
2. α 607B -- (6) double speed pushbuttons + (1) single speed pushbuttons
3. α 607AT -- (6) single speed pushbuttons + (1) SELECT I/II pushbutton
4. α 607BT -- (6) double speed pushbuttons + (1) SELECT I/II pushbutton
5. α 608A -- (8) single speed pushbuttons
6. α 608B -- (6) double speed pushbuttons + (2) single speed pushbuttons

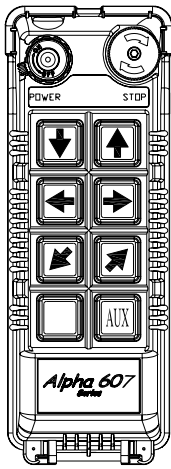

(Alpha 607A)

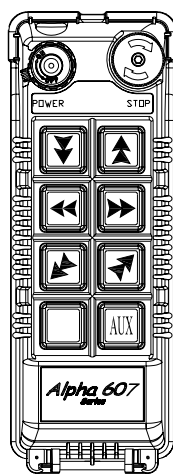

(Alpha 607B)

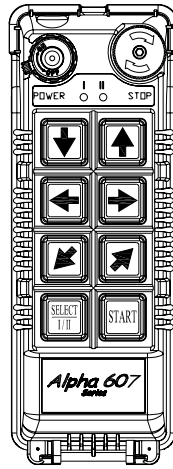

(Alpha 607AT)

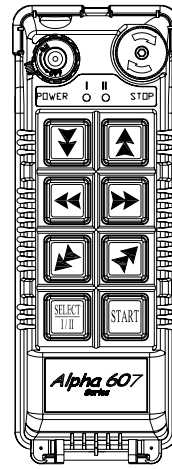

(Alpha 607BT)

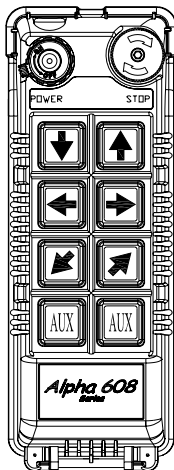

(Alpha 608A)

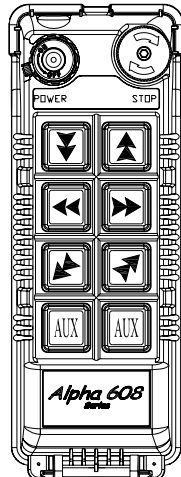

(Alpha 608B)

2.2 Alpha 612 Models

1. Alpha 612A → (12) one-speed pushbuttons
2. Alpha 612B → (11) one-speed pushbuttons + I/II select pushbutton*
3. Alpha 612C-1 → (6) two-speed + (6) one-speed pushbuttons
4. Alpha 612C-2 → (8) two-speed + (4) one-speed pushbuttons
5. Alpha 612D → (10) two-speed + (2) one-speed pushbuttons
6. Alpha 612E-1 → (6) two-speed + (5) one-speed pushbuttons + I/II select pushbutton*
7. Alpha 612E-1 → (8) two-speed + (3) one-speed pushbuttons + I/II select pushbutton*

* For cranes with auxiliary hoist and trolley (changeover function).

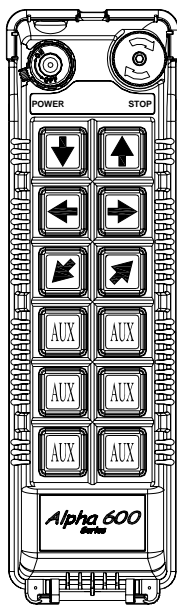

α 612A

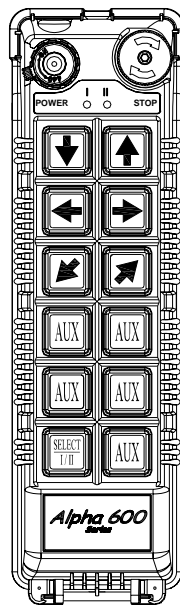

α 612B

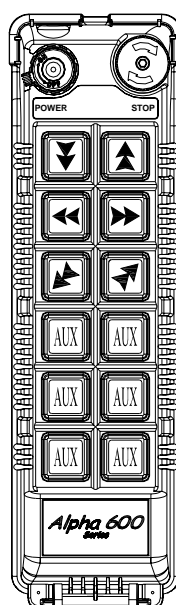

α 612C-1
 α 612C-2
 α 612D

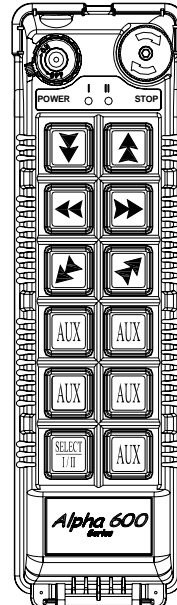

α 612E-1
 α 612E-2

3. TRANSMITTER OUTLINE

3.1 Transmitter Outline

3.1.1 Alpha 608

3.1.2.1 SIZE: 189mm X 68mm X 30mm

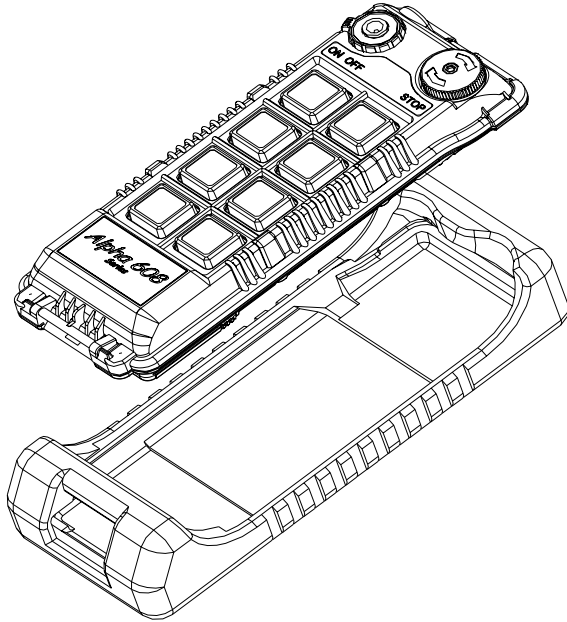

(Fig.1) Transmitter Outline

3.1.2.2 TX INTERNAL MODULE – encoder board

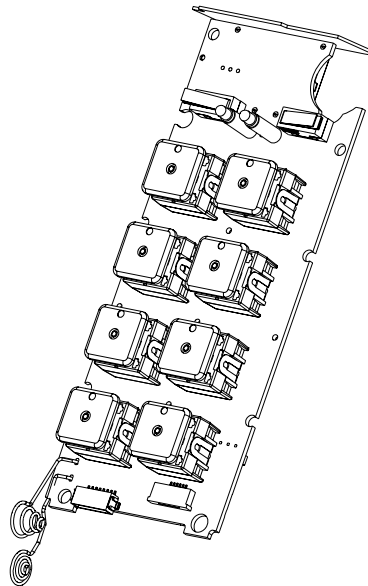

(Fig.4) Encoder board

3.1.2.3 TRANSMITTER INTERNAL ASSEMBLY

- (1) Internal antenna
- (2) Status LED display
- (3) Battery contact
- (5) Programming port
- (6) ID code dip-switch
- (7) JP2 setting pin
- (8) JP1 setting pin

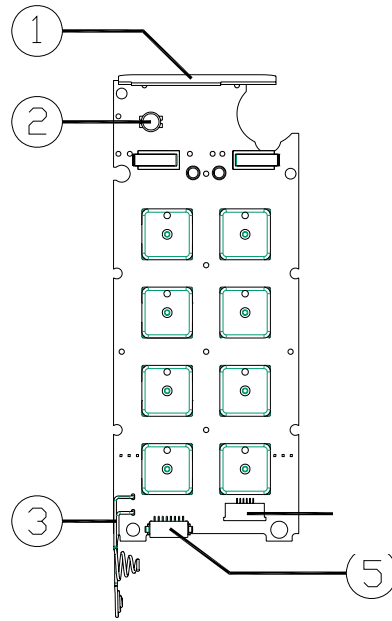

(Fig.2) Front View

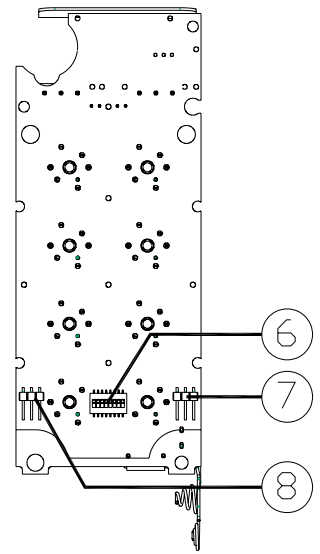

(Fig.3) Back View

3.1.3 Alpha 612

3.1.3.1 SIZE: 235mm X 68mm X 30mm

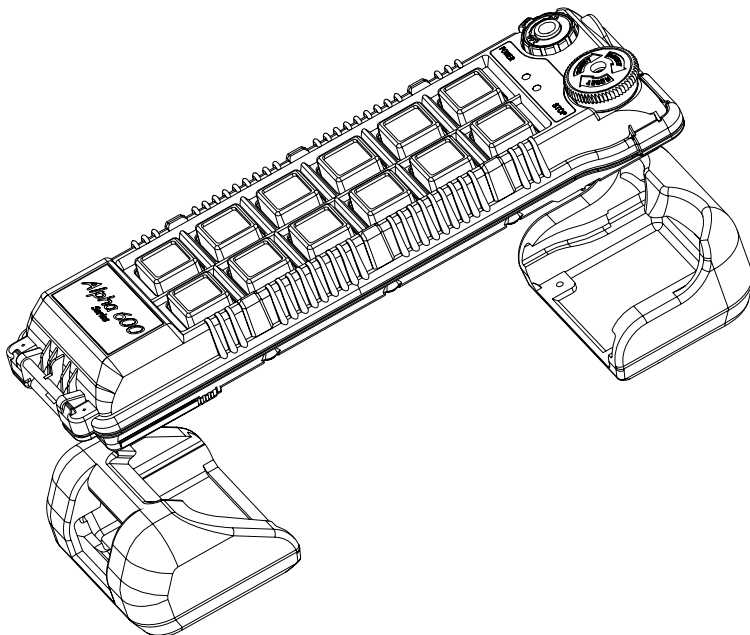

(Fig.1) Transmitter Outline

3.1.3.2 TX INTERNAL MODULE

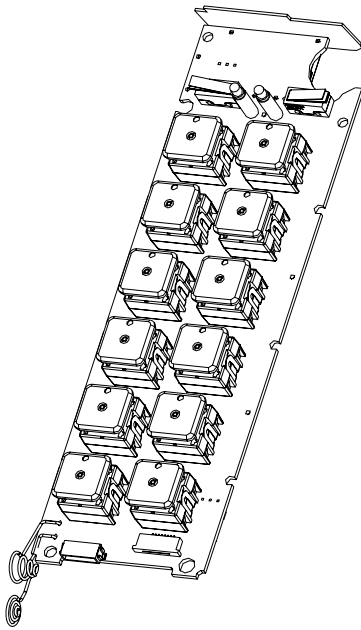

Encoder Board

3.1.3.3 TRANSMITTER INTERNAL ASSEMBLY

- (1) Internal antenna
- (2) Status LED display
- (3) Battery contact
- (5) Programming port
- (6) ID code dip-switch
- (7) JP2 setting pin
- (8) JP1 setting pin

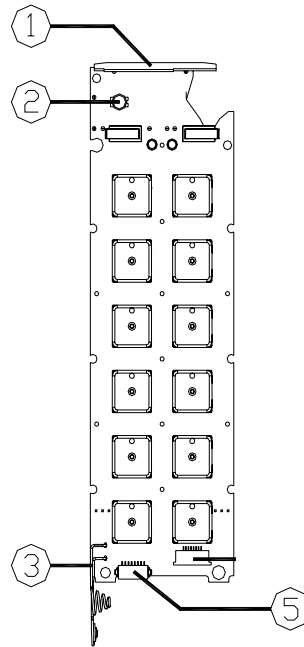

(Fig.2) Front View

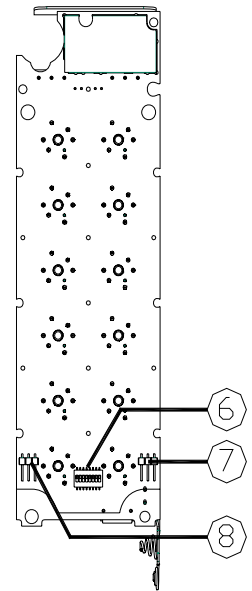

(Fig.3) Back View

3.2 Alpha 604/607/608/612 Spare Parts

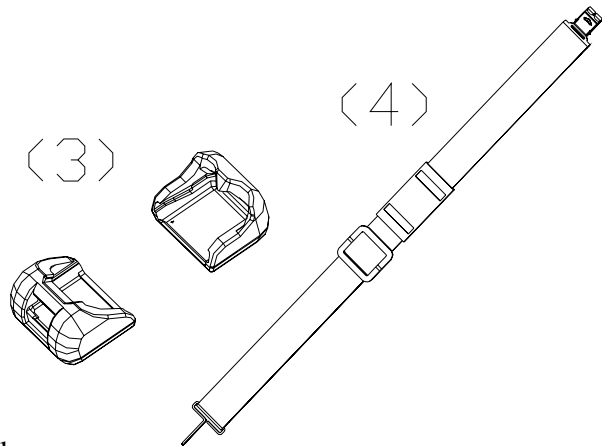

- (3) Transmitter shock-absorbing rubber
- (4) Shoulder strap

4. RECEIVER OUTLINE

4.1 Alpha 607/608

4.1.1 External Assembly

SIZE : 310mm X 134mm X 72mm

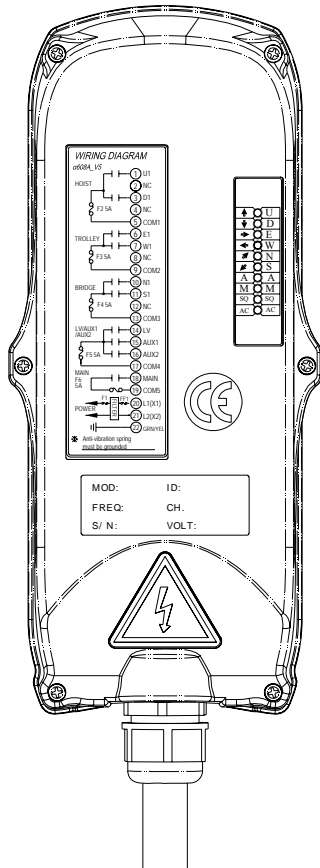

(Fig.7) Front View

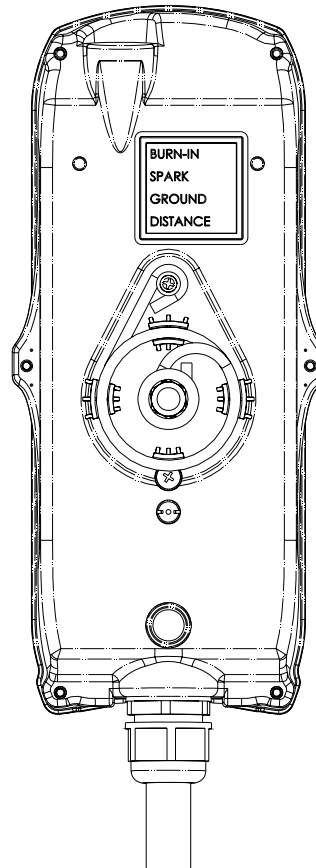

(Fig.8) Back View

4.1.2 Alpha 608 Internal Assembly

(Fig. 9) Internal Parts Assembly

- 1) Receiving RF module
- 2) External programming port
- 3) Secondary power AC fuse (0.50A)
- 4) Contact output seat (CN8)
- 5) Primary power AC fuse (1.0A)
- 6) AC power input seat (CN2)
- 7) Internal Antenna
- 8) System Status LED display*
- 9) External antenna port
- 10) ID code dip-switch
- 11) RF channel dip-switch
- 12) Contact relay LED display
- 13) Pushbutton #1 and #2 fuse (5.0A)
- 14) Contact output seat (CN3)
- 15) MAIN contact fuse (5.0A)
- 16) Pushbutton #3 and #4 fuse (5.0A)
- 17) Pushbutton #5 and #6 fuse (5.0A)
- 18) Contact output seat (CN4)
- 19) LV & AUX fuse (5.0A)
- 20) Cable gland & output cable

* Please refer to page 27 for system status LED display information.

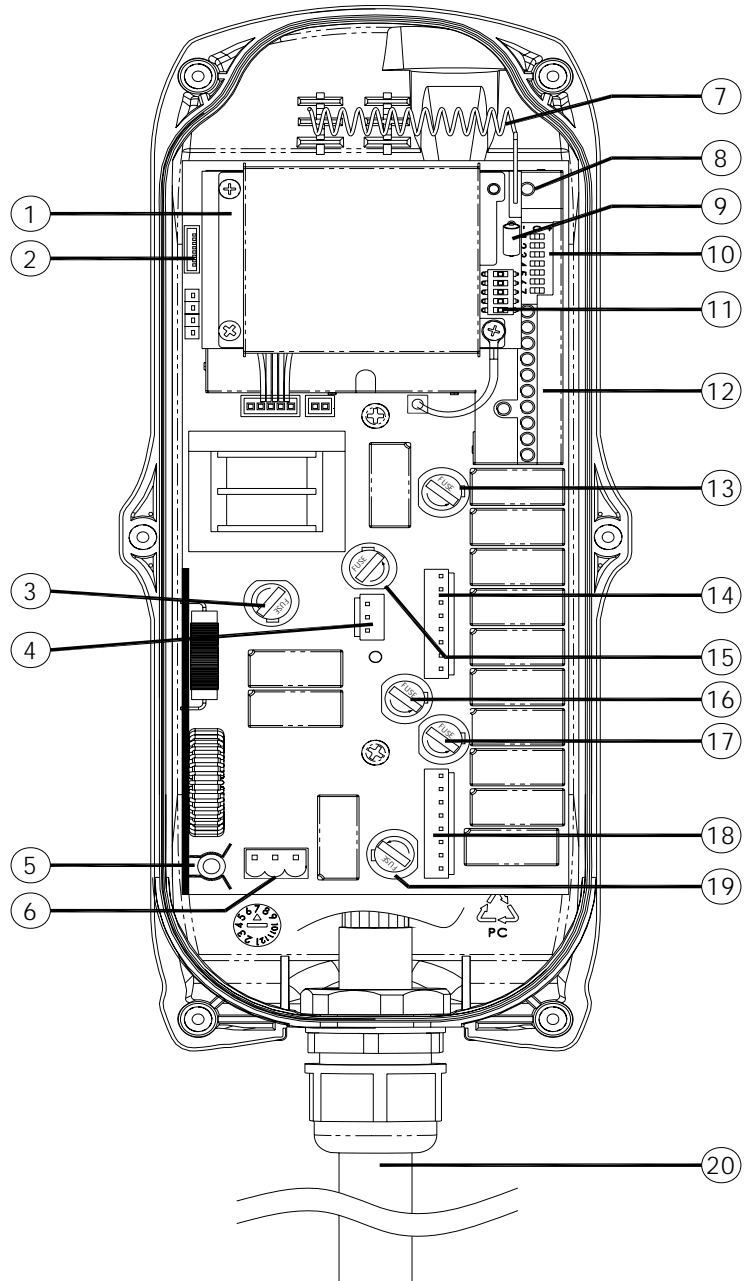

4.2 Alpha 612

4.2.1 External Assembly

SIZE : 300mm X 230mm X 86mm

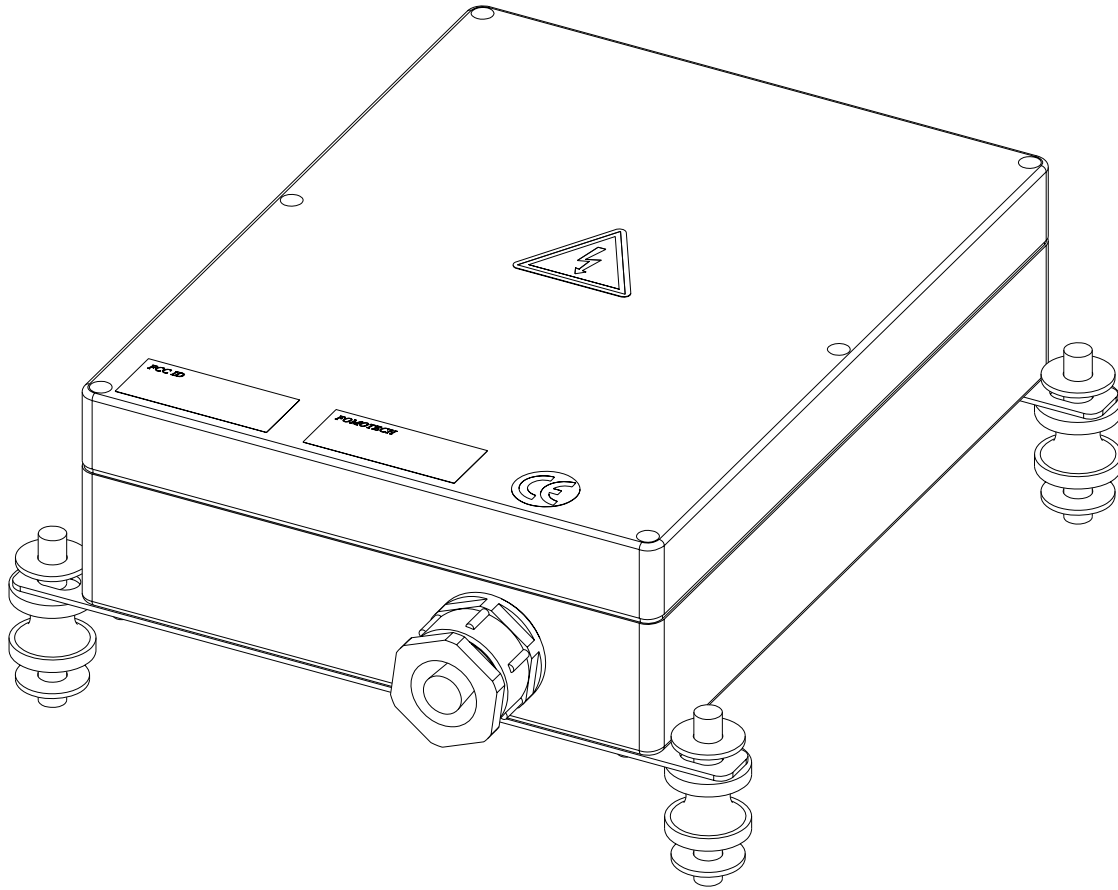

(Fig. 17) External Parts Assembly

- | | | | |
|----|-------------------------|----|---------------------------------------|
| 1) | Transparent top cover | 3) | Mounting bracket with shock absorbers |
| 2) | Light-gray colored base | 4) | Cable gland / Cord grip |

4.2.2 Alpha 612 Internal Assembly

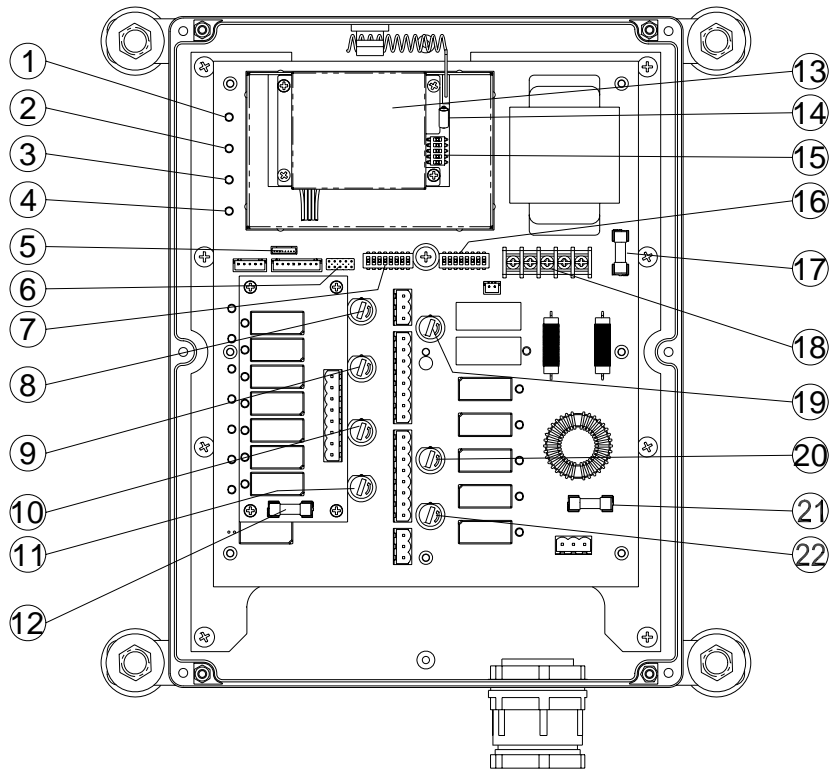

(Fig. 18) Internal Parts Assembly

- | | |
|--|--|
| 1) Power LED display* | 12) Pushbutton #1 and #2 relay fuse (5.0A) |
| 2) SQ LED display** | 13) Receiving RF module |
| 3) Status LED display**** | 14) External antenna port |
| 4) DC power relay LED display*** | 15) RF channel dip-switch |
| 5) Programming port | 16) ID code dip-switch |
| 6) Jumper settings | 17) Secondary power fuse (0.8A) |
| 7) Function dip-switch | 18) Voltage selector seat |
| 8) Pushbutton #3 and #4 relay fuse (5.0A) | 19) MAIN relay fuse (5.0A) |
| 9) Pushbutton #5 and #6 relay fuse (5.0A) | 20) Pushbutton A4 relay fuse (5.0A) |
| 10) Pushbutton A1 and A2 relay fuse (5.0A) | 21) Primary power fuse (1.0A) |
| 11) Pushbutton A3 relay fuse (5.0A) | 22) Low-voltage (LV) relay fuse (5.0A) |

* **POWER** ~ AC Power Source Indicator "on" → AC input power supplied.
 "off" → No AC input power.

** **SQ** ~ RF Signal Indicator "on" → RF signal detected and received.
 "off" → No RF signal detected or received.

Blinking at transmitter power "off" → Other radio interference.

*** **RELAY_COM** ~ DC Power Source to Relays "on" → DC power to relays.
 "off" → No DC power to relays.

**** **STATUS** ~ Receiver System Status LED Display → Please refer to page 32.

5. OUTPUT CONTACT DIAGRAMS

5.1 Alpha 607 Models

(Alpha 607A)

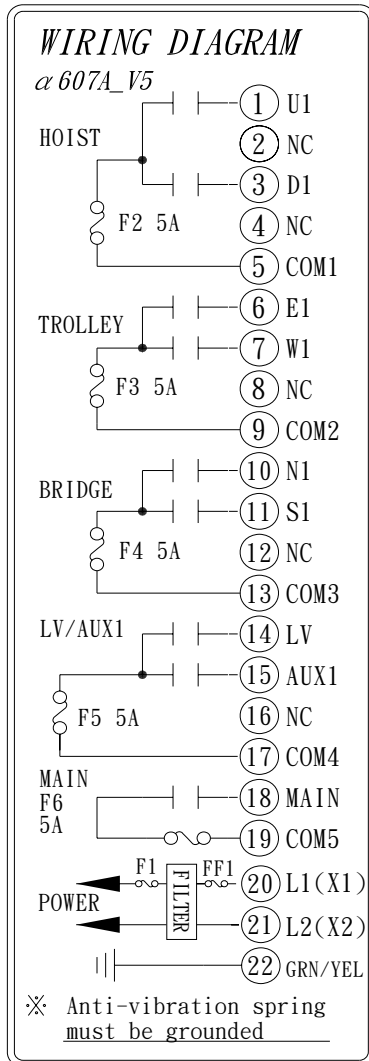

(Alpha 607B)

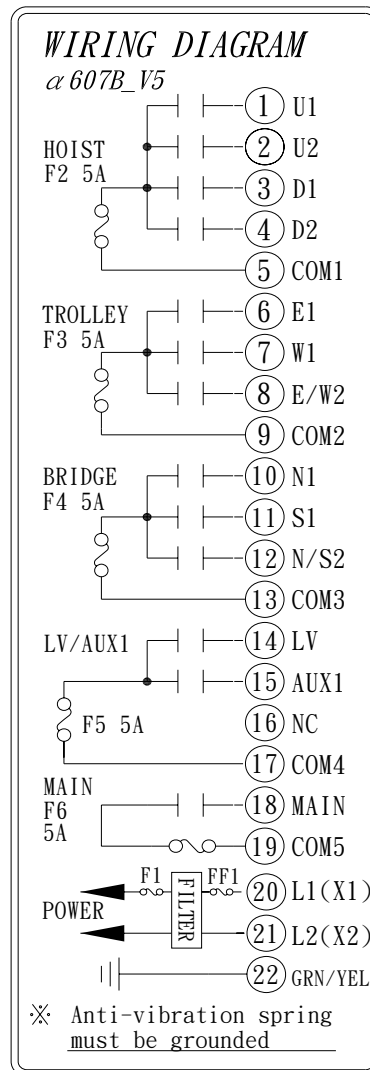

(Alpha 607AT)

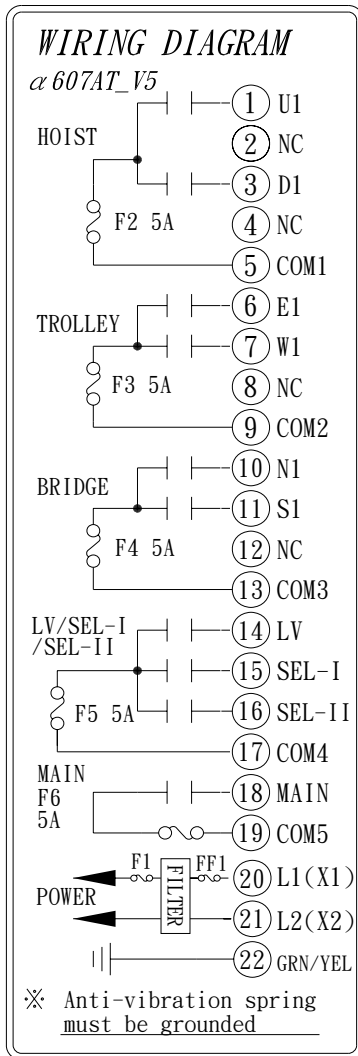

(Alpha 607BT)

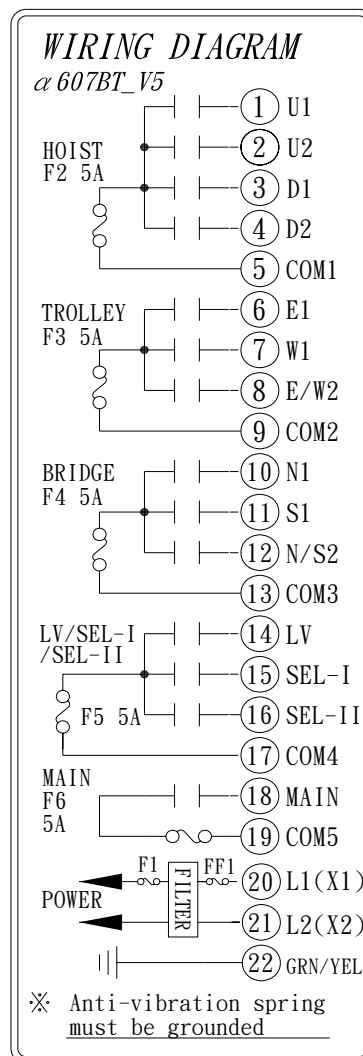

5.2 Alpha 608 Models

(Alpha 608A)

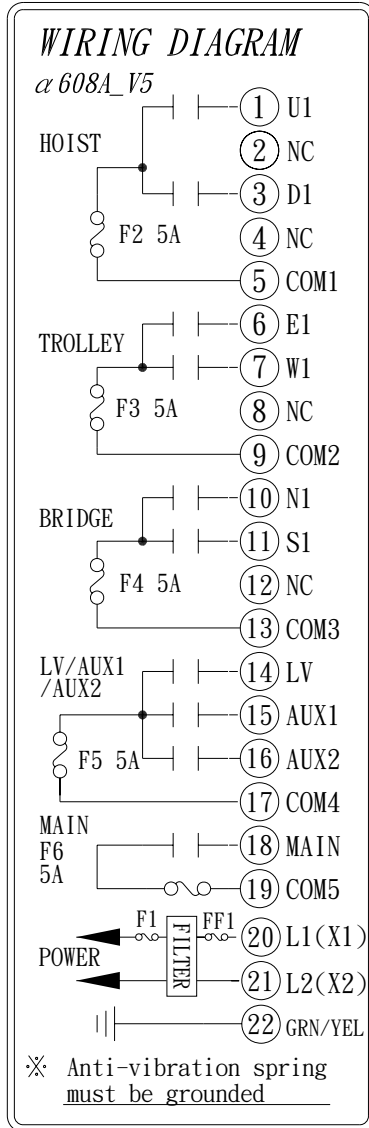

(Alpha 608B)

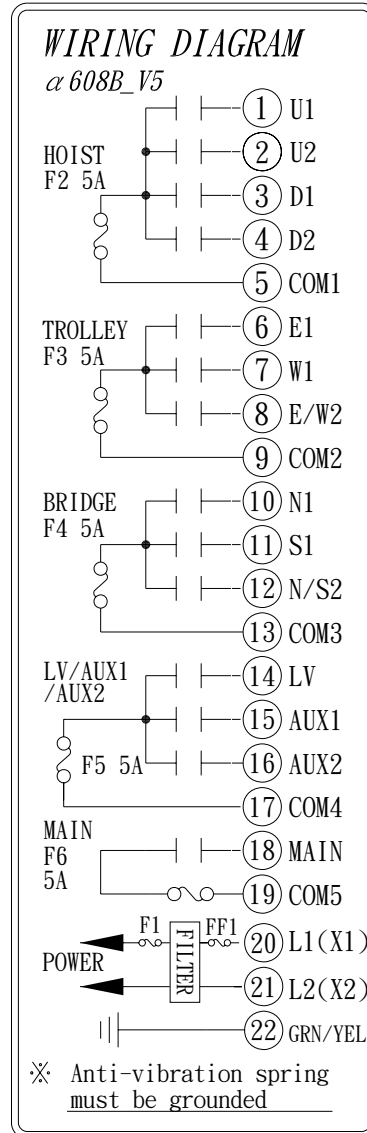

5.3 Alpha 612 Models

(Alpha 612A) – same as Alpha 580A+2

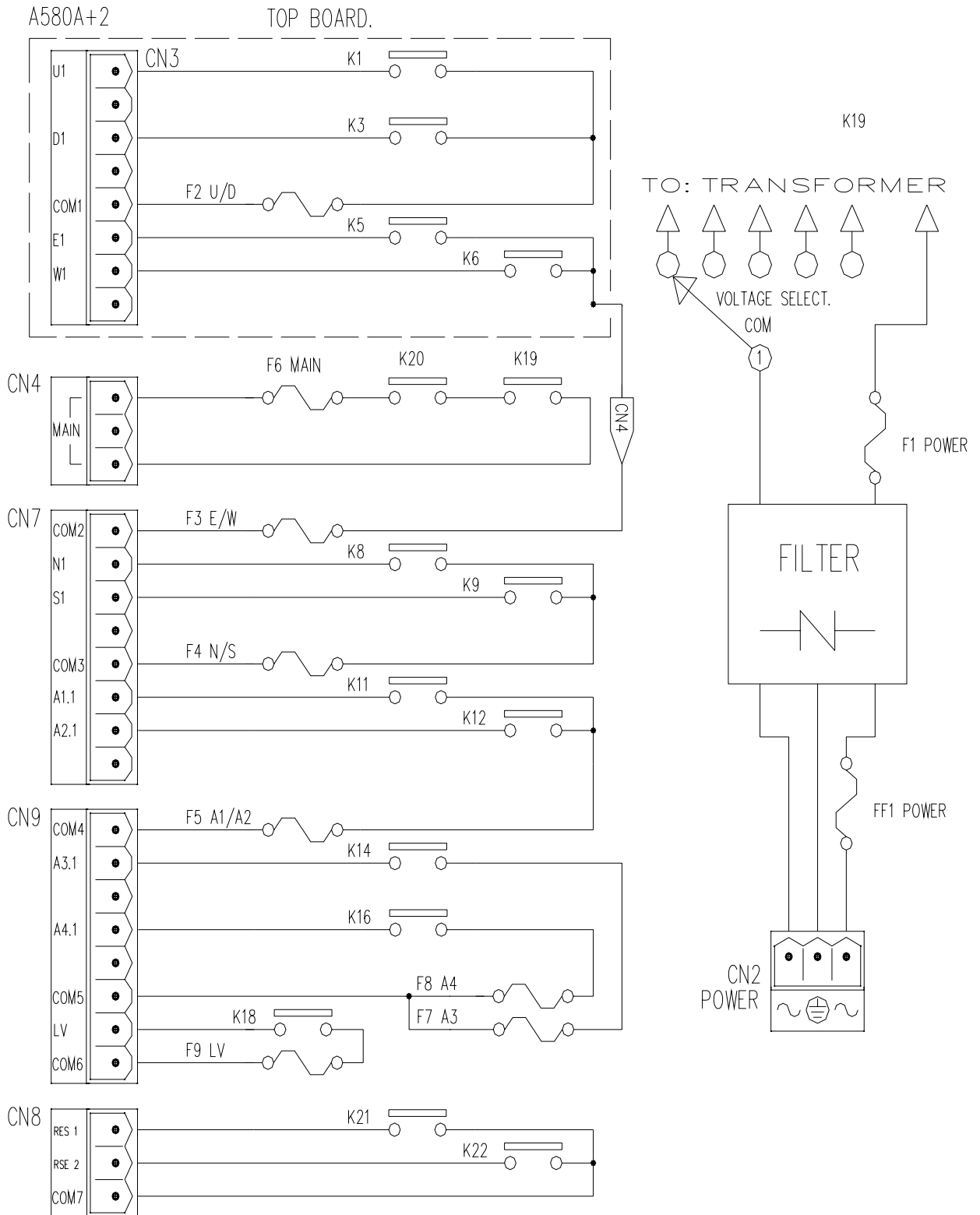

(Alpha 612B) – same as Alpha 580B+2

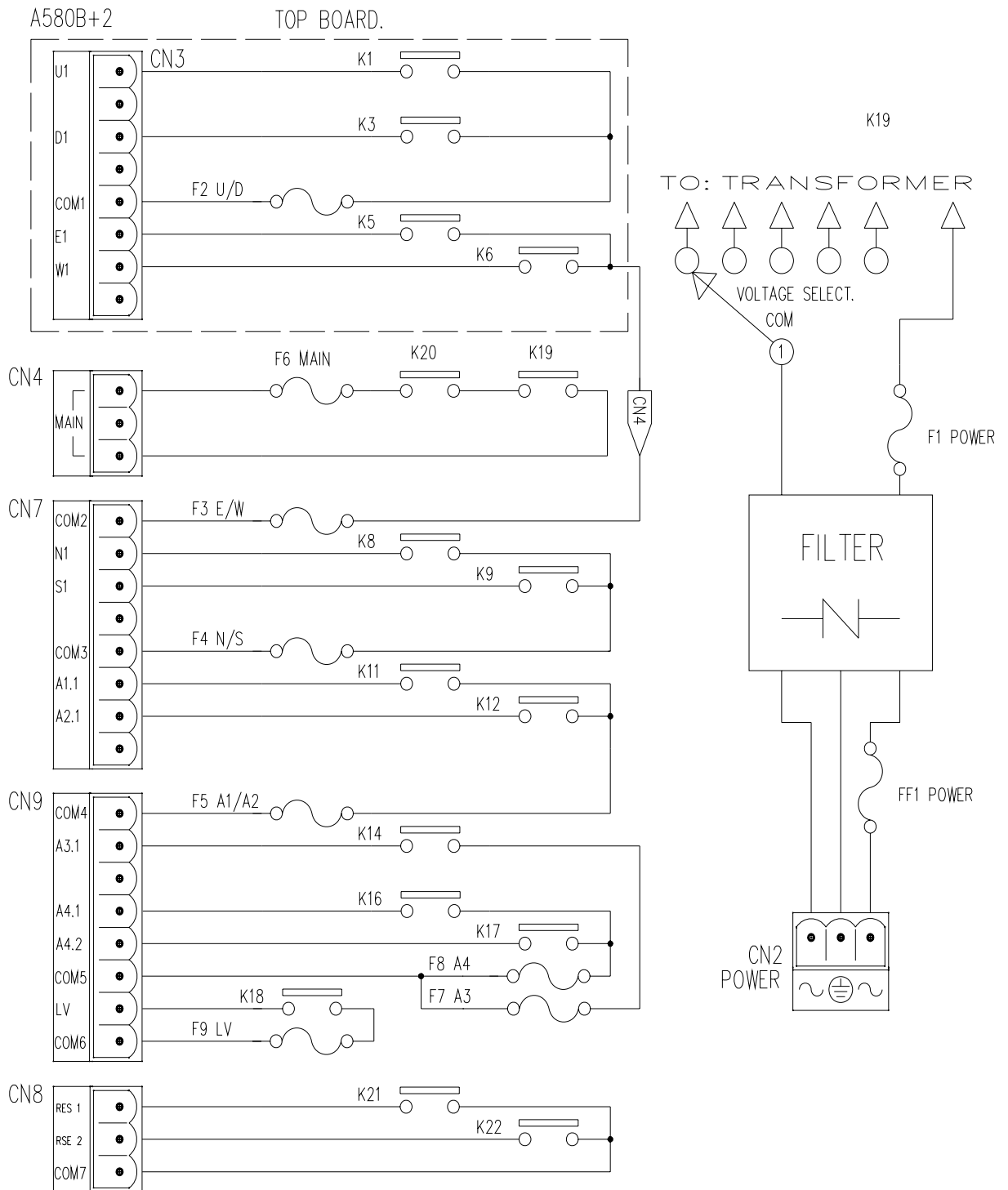

(Alpha 612C-1) – same as Alpha 580C-1+2

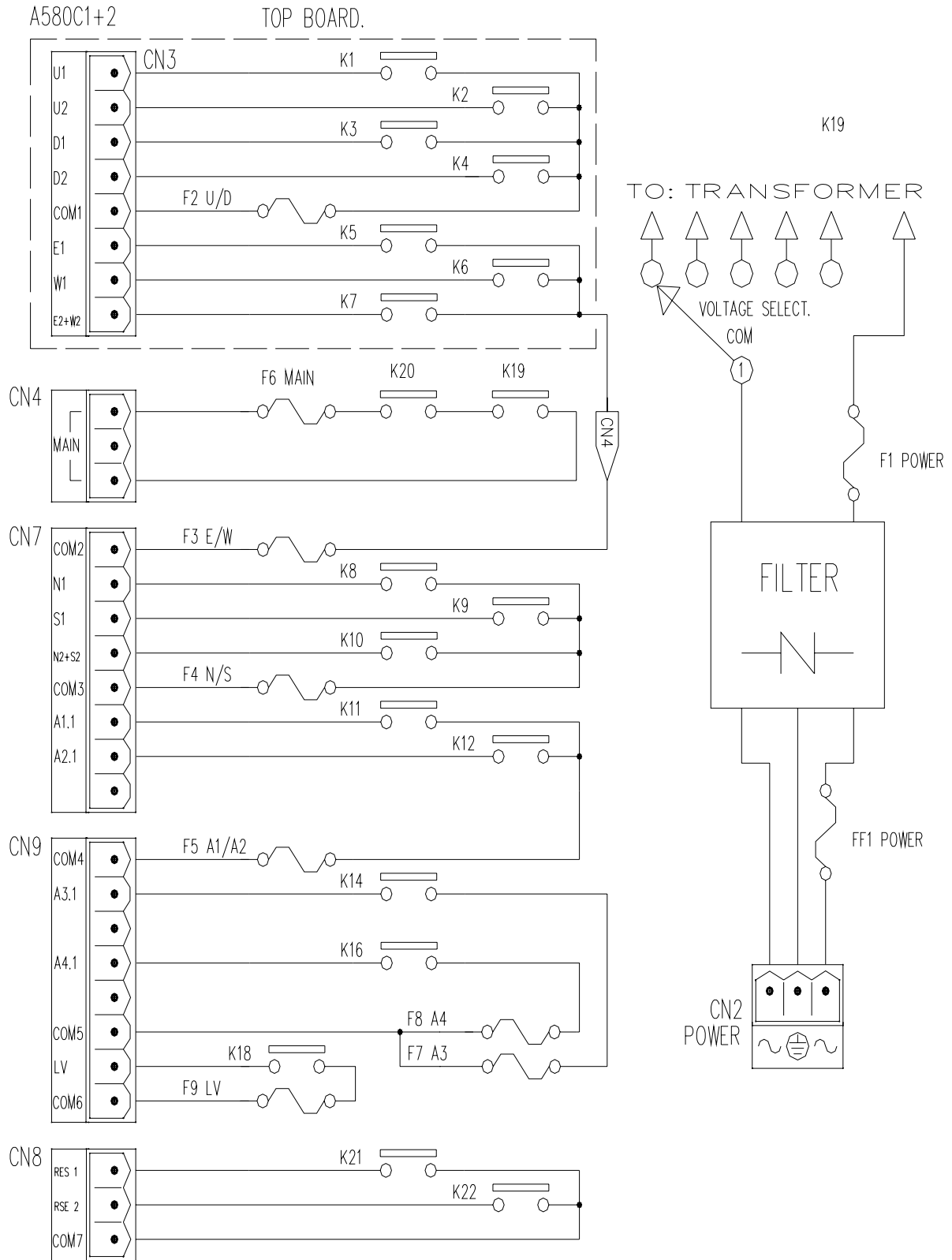

(Alpha 612C-2) – same as Alpha 580C-2+2

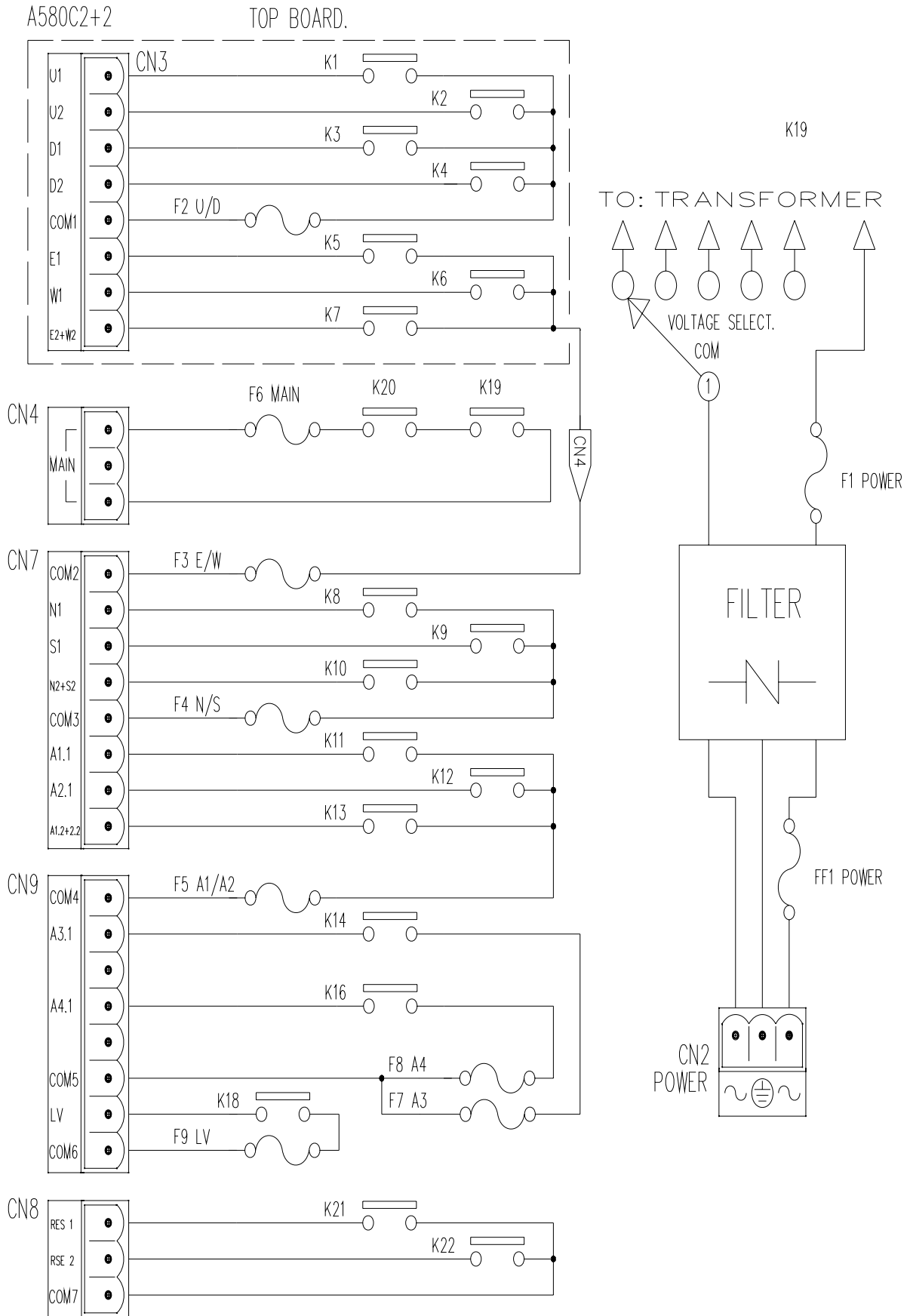

(Alpha 612D) – same as Alpha 580D+2

A580D+2

TOP BOARD.

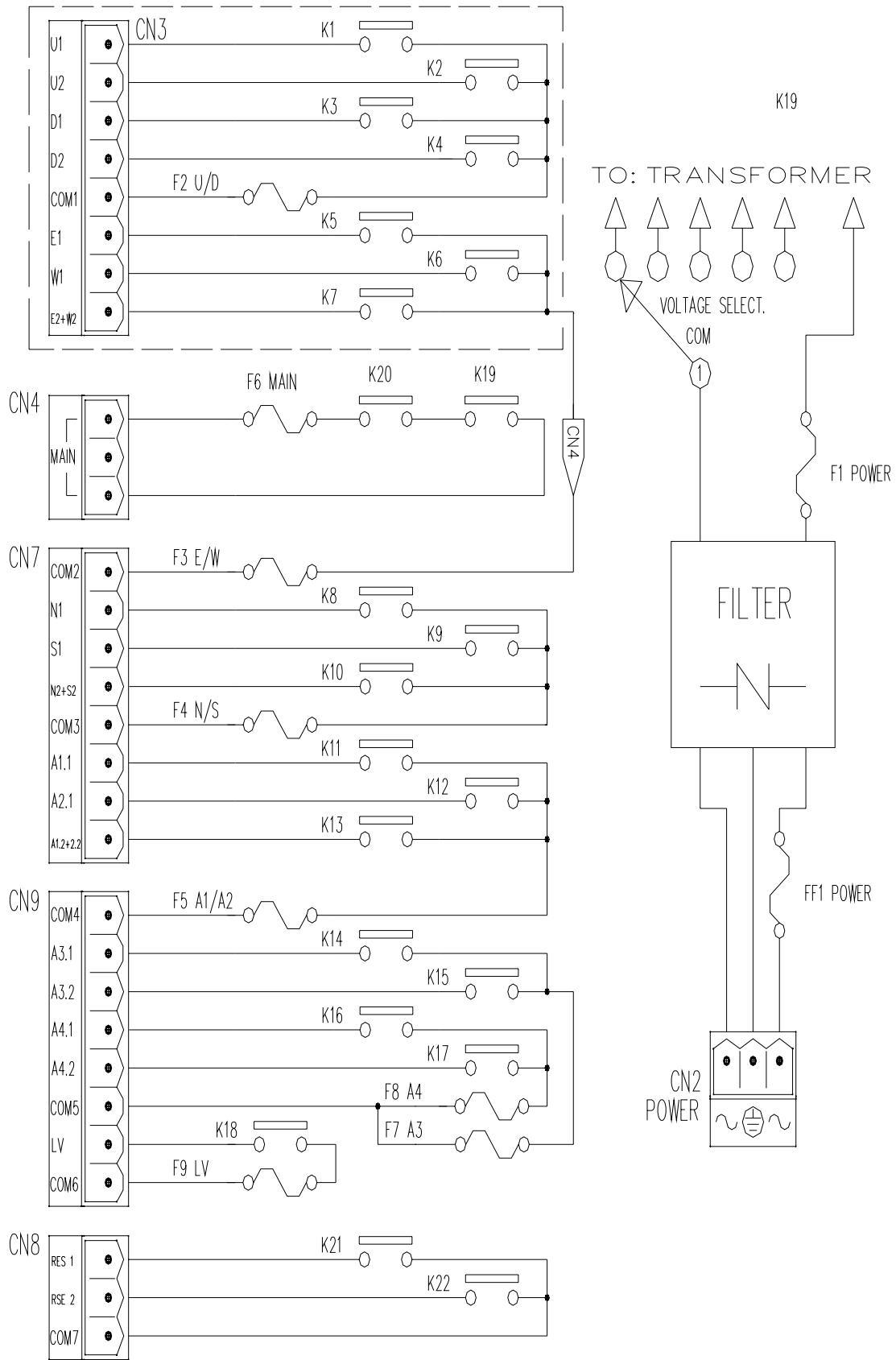

(Alpha 612E-1) – same as Alpha 580E-1+2

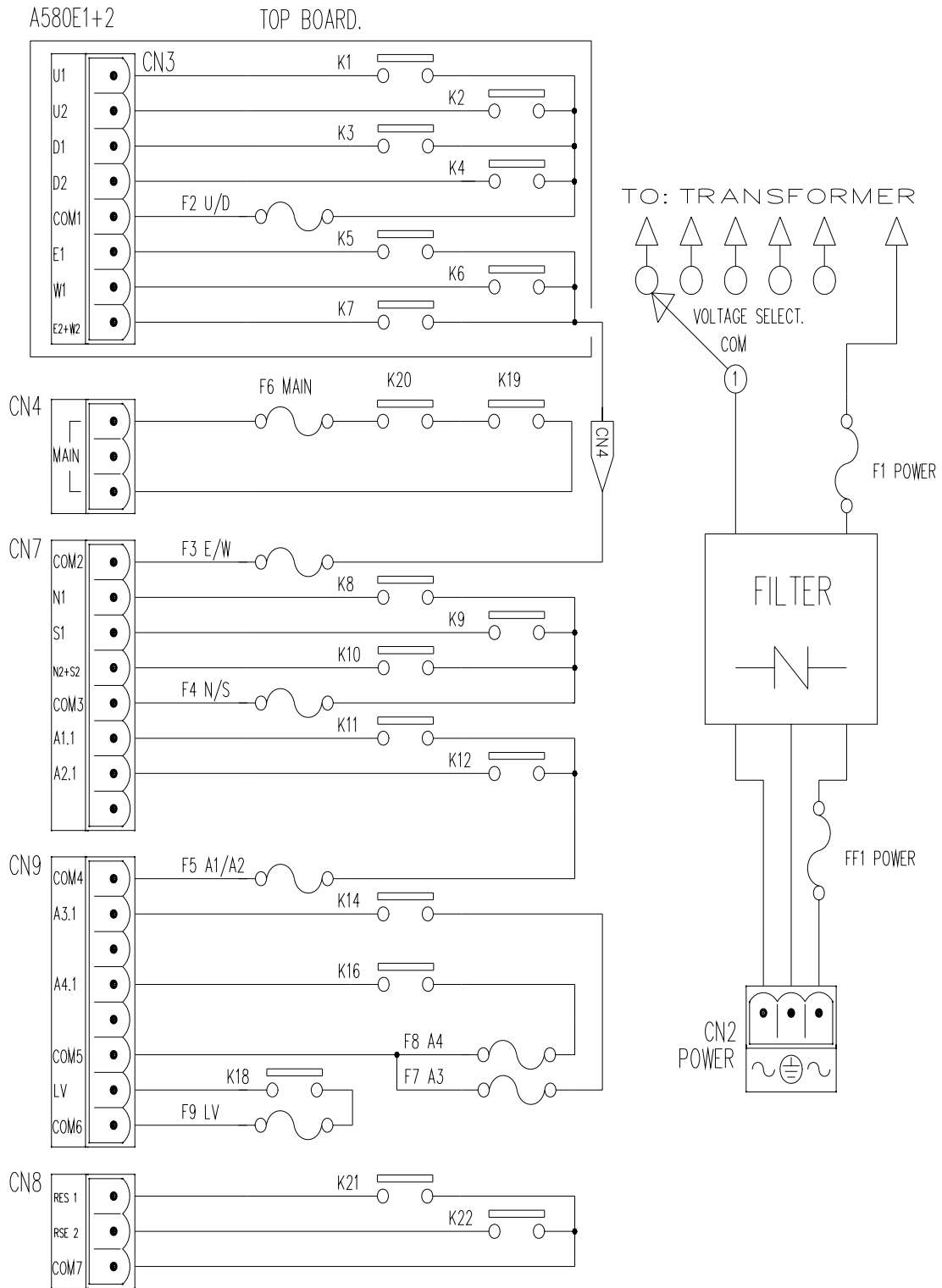

(Alpha 612E-2) – same as Alpha 580E-2+2

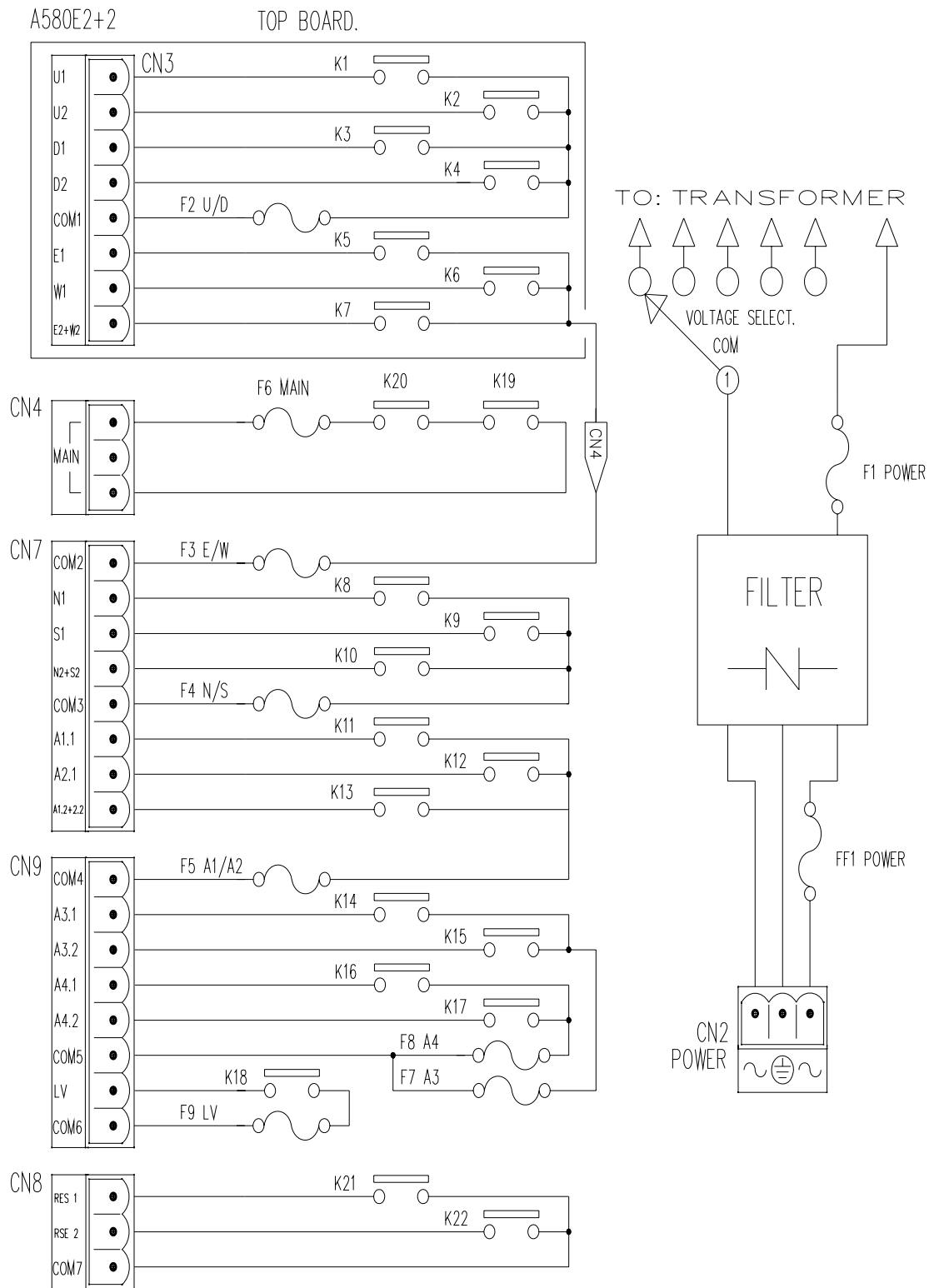

6. TRANSMITTER SETTINGS

6.1 How to Set ID Codes

6.1.1 Set by programming tool

6.1.2 Set by encoder board JP1, 1st / 2nd pin and dip-switch

Setting Steps:

- (1) Rotate the transmitter power to OFF position
- (2) Disassemble shock-absorbing rubber
- (3) Put the transmitter pushbutton downward and disassemble transmitter bottom casing.
- (4) Set ID code with dip-switch and put short boot on 1st / 2nd pin of JP1.
- (5) Make sure the batteries are installed properly.
- (6) Rotate the transmitter power switch to ON position.
- (7) Green status LED ON for 0.1 sec, OFF for 0.1 sec, flash for 1 sec. (5 times)
- (8) Green status LED steady ON indicates the setting is completed. If the LED status light is changed to red, the setting is failed. Please repeat the above setting steps until the setting is successful.
- (9) After setting is completed and successful, remove short boot on 1, 2 pin of JP1.
- (10) Rotate transmitter power switch to OFF position.

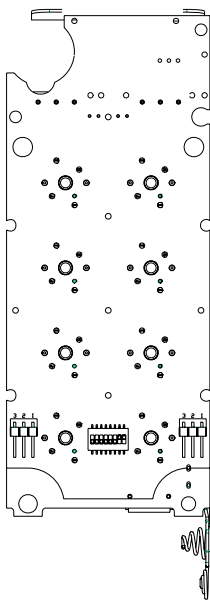

(Fig. 10) Back view

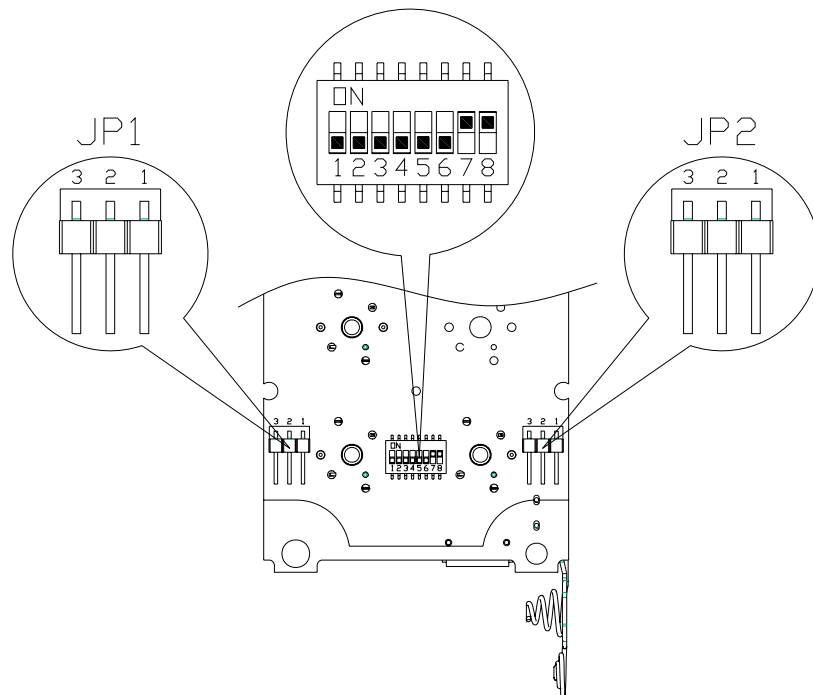

(Fig. 11) Position of dip-switch & jumpers

Top slot ON → “1”; bottom slot → “0”. The setting above is 00000011.

6.2 Transmitter Channel Settings

Transmitter channel setting (select the channel you would like to operate. No exceed to channel limit)

6.2.1 Set by programming tool

6.2.2 Set by encoder board 2nd & 3rd pin of JP1 and dip-switch

When setting frequency on TX board JP1, put short boot on 2nd & 3rd pin of JP1. Change the frequency needed by changing the dip-switch setting. Repeat the previous steps to set frequency.

(Note: set the dip-switch from the 4th digit)

Example : Set channel as 03→(00000011) → Correct setting



7. RECEIVER SETTINGS

7.1 How to Set 607/608/612 Receiver ID Codes

7.1.1 How to Set 607/608 Receiver ID Code

Top slot → “1”

Bottom slot → “0”

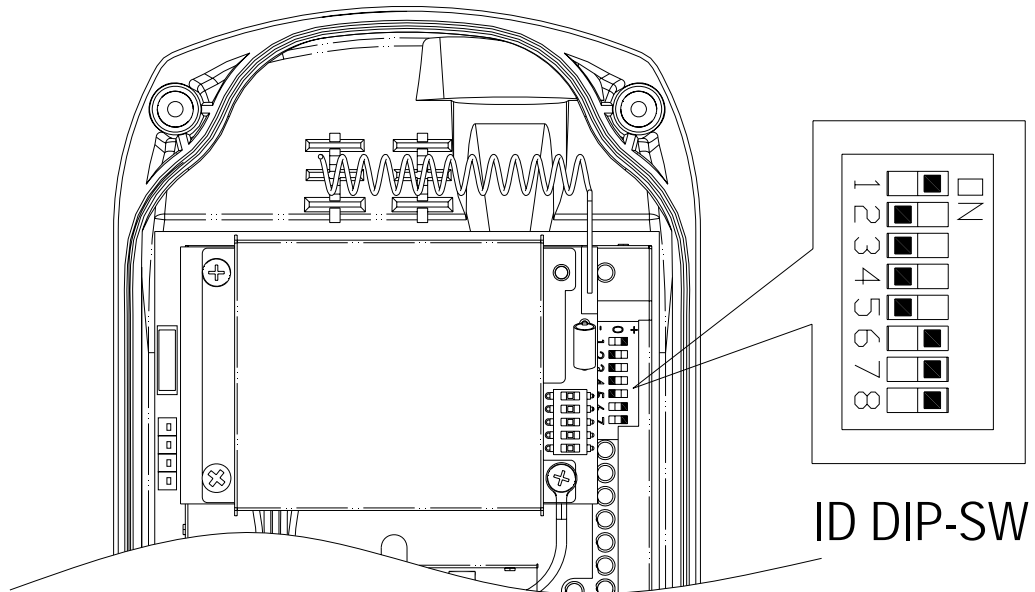

Set the ID codes needed on the decoder board dip-switch. For example: the ID codes set above → 10000111.

7.1.2 How to set α612 Receiver ID Code

Please refer Fig. 18 receiver internal parts assembly (Page 17) for ID code 8-position dip-switch to set receiver ID code.

Top slot → “1” ; bottom slot → “0”

Set the ID codes needed on the decoder board dip-switch.

For example: the ID codes → 10010110

(“1” value adds up must to be “4”)

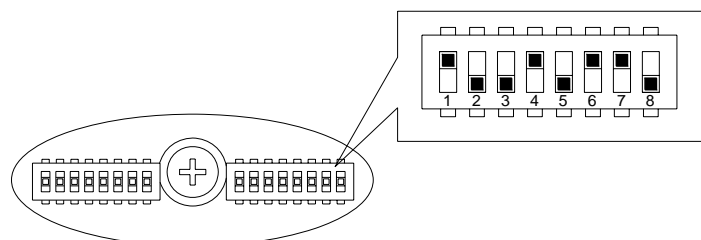

7.2 Receiver RF Channel Setting

There are 68 sets of user-adjustable receiving RF channels that can be set manually via a 8-position dip-switch located to the right of the receiving RF module. Change the receiving RF channel simply by resetting these 8-position dip-switch. For the location of the receiving RF module, please refer to fig. 15, 16, and 18 on page 11, 12, and 14.

Top slot → “1” ; bottom slot → “0”

For example : the channel dip-switch set above → 00000101, channel 05.

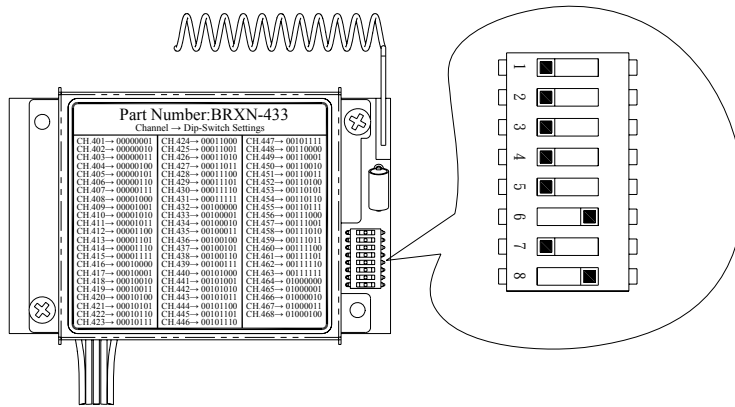

7.3 Receiver Function Setting

7.3.1 607/608 Receiver Function Setting

7.3.1.1 Set by programming tool

7.3.1.2. Adjust Jumper setting function by decoder board

Receiver function setting:

- Select any pushbutton or ON/OFF power switch to start the system. The MAIN relay will be activated when system is started. (After the receiver power is started and emergency stop button is elevated)
- The MAIN relay auto shutdown time can be set as 3 minutes or depends on customer's single request. (Remark 1)
- When transmitter voltage is low, relays for the receiver MAIN and LV (Remark 1) will be auto shutdown after one minute.

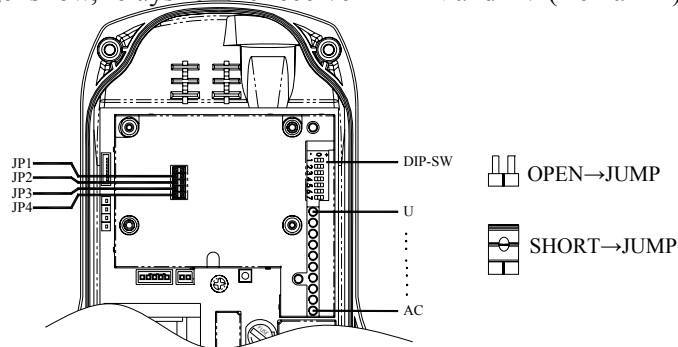

(Fig. 12) Alpha 607, 608 models

Jumper Set table: in-plant setting (default).

JP1	Open	Power key to activate relay MAIN relay (After turning “on” the transmitter power and pressing the emergency Stop button)
JP2	Open	No auto shutdown time on Main relay
	Short	The receiver MAIN will be deactivated after consecutive 5 minutes of standby time.
JP3	Open	No auto shutdown time on MAIN and LV relays
	Short	After one minute of transmitter LV, the MAIN and LV relays will be deactivated.
JP4	Open	7 th AUX: “Normal” pushbutton setting
	Short	7 th AUX: “Toggle” pushbutton setting

※ *Open* → *no Jumper*

Short → *put Jumper*

Remark 1 : The setting of auto shutdown time can be done by manufacturer or distributor. Setting range: 0~30 minutes. (In-plant setting: 5 minutes)

Remark 2 : When the transmitter voltage is low, LV relay will be activated and siren or lights will be ON. (one second of interval)

Remark 3 : Every time when you change jumper settings you must first turn the receiver power off and then turn it back on so that the new settings can be stored in memory.

7.3.2 α 612 Receiver Function Setting

7.3.2.1 Set by programming tool

7.3.2.2. Adjust Jumper setting function by decoder board

Receiver function setting:

Jumper Set table: In-plant setting (default).

JP1	Open	Power key to activate relay MAIN relay (After turning “on” the transmitter power and pressing the emergency stop button)
JP2	Open	No auto shutdown time on Main relay
	Short	The receiver MAIN will be deactivated after consecutive 5 minutes of standby time.
JP3	Open	No auto shutdown time on MAIN and LV relays
	Short	After one minute of transmitter LV, the MAIN and LV relays will be deactivated.

※ *Open* → *No jumper*

Short → *Put Jumper*

Remark 1 : The setting of auto shutdown time can be done by manufacturer or distributor. Setting range: 0~30 minutes. (In-plant setting: 5 minutes)

Remark 2 : When the transmitter voltage is low, LV relay will be activated and siren or lights will be ON. (One second of interval)

Remark 3 : Every time when you change jumper settings you must first turn the receiver power off and then turn it back on so that the new settings can be stored in memory.

7.3.3 Alpha 612 Models Dip-Switch Function Table

Model	Pushbutton	Dip-Switch Setting		Description	
612A	1 & 2 3 & 4 5 & 6	DIP 1	→ 1	Not Interlocked	
			→ 0	Interlocked	
	7 & 8	DIP 2	→ 1	Not Interlocked	
			→ 0	Interlocked	
	7 & 8	DIP 3	→ 1	Latching/toggle relay contact	DIP2 Set at “1”
			→ 0	Momentary relay contact	
	9 & 10	DIP 4	→ 1	Not Interlocked	
			→ 0	Interlocked	
612B	9	DIP 5	→ 1	Latching/toggle relay contact	DIP4 Set at “1”
			→ 0	Momentary relay contact	
	10	DIP 6	→ 1	Latching/toggle relay contact	DIP4 Set at “1”
			→ 0	Momentary relay contact	
612B	7 & 8	DIP 1	→ 1	Not Interlocked	
			→ 0	Interlocked	
	7	DIP 2	→ 1	Latching/toggle relay contact	
			→ 0	Momentary relay contact	DIP4 Set at “1”
	8	DIP 3	→ 1	Latching/toggle relay contact	DIP4 Set at “1”
			→ 0	Momentary relay contact	
	9	DIP 4	→ 1	Latching/toggle relay contact	
			→ 0	Momentary relay contact	
612C	1 & 2 (2 nd speed)	DIP 1	→ 1	Both 1 st and 2 nd speed contact relay interlocked when pressed to 2 nd speed	Both 1 st and 2 nd speed contact relays activated
			→ 0	Both 1 st and 2 nd speed contact relay activated when pressed to 2 nd speed	Only 2 nd speed contact relay activated

	9	DIP 2,3	→ 00	Momentary relay contact	
		DIP 2,3	→ 01	Latching/toggle relay contact	
		DIP 2,3	→ 10	Activate the 3 rd speed	
	10	DIP 4	→ 1	Latching/toggle relay contact	
→ 0			Momentary relay contact		
612D	1 & 2 (2 nd speed)	DIP 1	→ 1	Both 1 st and 2 nd speed contact relay interlocked when pressed to 2 nd speed	Both 1 st and 2 nd speed contact relays activated
			→ 0	Both 1 st and 2 nd speed contact relay activated when pressed to 2 nd speed	Only 2 nd speed contact relay activated
	---	DIP 2,3,4	→0	Momentary relay contact	DIP2&3 Must set to "0" all the time (In-plant set at "0")
612E	1 & 2 (2 nd speed)	DIP 1	→ 1	Both 1 st and 2 nd speed contact relay interlocked when pressed to 2 nd speed	Both 1 st and 2 nd speed contact relays activated
			→ 0	Both 1 st and 2 nd speed contact relay activated when pressed to 2 nd speed	Only 2 nd speed contact relay activated
	7 & 8	DIP 2	→ 1	Not Interlocked	
			→ 0	Interlocked	
	7	DIP 3	→ 1	Latching/toggle relay contact	DIP2 Set at "1"
→ 0			Momentary relay contact		
612 A/B/C/D/E	11	DIP 7	→ 1	Latching/toggle relay contact	
			→ 0	Momentary relay contact	
	12	DIP 8	→ 1	Latching/toggle relay contact	
			→ 0	Momentary relay contact	

※ In-plant all set at "0"

7.4 Frequency (RF) Channels Table

FREQUENCY	DIP-SWITCH SETTING	CHANNEL
433.075 MHz	00000001	01
433.100 MHz	00000010	02
433.125 MHz	00000011	03
433.150 MHz	00000100	04
433.175 MHz	00000101	05
433.200 MHz	00000110	06
433.225 MHz	00000111	07
433.250 MHz	00001000	08
433.275 MHz	00001001	09
433.300 MHz	00001010	10
433.825 MHz	00001011	11
433.850 MHz	00001100	12
433.875 MHz	00001101	13
433.900 MHz	00001110	14
433.925 MHz	00001111	15
433.950 MHz	00010000	16
433.975 MHz	00010001	17
434.000 MHz	00010010	18
434.025 MHz	00010011	19
434.050 MHz	00010100	20
434.075 MHz	00010101	21
434.100 MHz	00010110	22
434.125 MHz	00010111	23
434.150 MHz	00011000	24
434.175 MHz	00011001	25
434.200 MHz	00011010	26
434.225 MHz	00011011	27
434.250 MHz	00011100	28
434.275 MHz	00011101	29
434.300 MHz	00011110	30
434.325 MHz	00011111	31
434.350 MHz	00100000	32
434.375 MHz	00100001	33

FREQUENCY	DIP-SWITCH SETTING	CHANNEL
434.400 MHz	00100010	34
434.425 MHz	00100011	35
434.450 MHz	00100100	36
434.475 MHz	00100101	37
434.500 MHz	00100110	38
434.525 MHz	00100111	39
434.550 MHz	00101000	40
434.575 MHz	00101001	41
434.600 MHz	00101010	42
434.625 MHz	00101011	43
434.650 MHz	00101100	44
434.675 MHz	00101101	45
434.700 MHz	00101110	46
434.725 MHz	00101111	47
434.750 MHz	00110000	48
434.775 MHz	00110001	49
433.325 MHz	00110010	50
433.350 MHz	00110011	51
433.375 MHz	00110100	52
433.400 MHz	00110101	53
433.425 MHz	00110110	54
433.450 MHz	00110111	55
433.475 MHz	00111000	56
433.500 MHz	00111001	57
433.525 MHz	00111010	58
433.550 MHz	00111011	59
433.575 MHz	00111100	60
433.600 MHz	00111101	61
433.625 MHz	00111110	62
433.650 MHz	00111111	63
433.675 MHz	01000000	64
433.700 MHz	01000001	65
433.725 MHz	01000010	66
433.750 MHz	01000011	67
433.775 MHz	01000100	68

8. TRANSMITTER OPERATION & STATUS

LIGHT

8.1 Transmitter Operating Steps

1. Make sure the two “AA” NiMH rechargeable batteries are installed correctly. Please note the polarity of the batteries.
2. **Status lights**_To operate the transmitter, please rotate the power key on the top-left corner clockwise to “on” position. The status LED (green and red) will be steady “on” for 2 seconds and then “off”. If the transmitter Status LED displays a red blinking light that is “on” → 0.1 second and “off” → 1.9 seconds, or no light at all, this indicates the transmitter with batteries needs to be recharged.
3. When any function pushbutton is depressed, the transmitter Status LED displays a red blinking light that is “on”→ 0.1 second and “off”→ 1.9 seconds. If the voltage is low, the transmitter Status LED will be “on”→0.1 second and “off”→1.9 seconds, this indicates the transmitter with batteries needs to be recharged. Continuous operation will cause the transmitter battery power exhausting and cannot operate at all.
4. **EMS & Restarting** _ In case of an emergency, press down the red emergency stop button (EMS) will immediately deactivates the transmitter and receiver MAIN relay. The transmitter Status LED will be blinking “on”→0.5 second and “off”→0.5 second for 30 seconds (Mode 0). Then turn off the transmitter power.
5. The emergency stop button is a right-rotate momentary spring-return type. To turn on the transmitter and activate the MAIN relay, please elevate the emergency stop button again and rotate the transmitter power key to “ON” position.
6. Note that the transmitter cannot be hit by outer force, so that malfunction can be prevented.
7. The operating temperature is -10 ~ +50°C. Avoid operating the transmitter in high temperature workshop. If operating temperature is higher than 50°C, the auto shutdown protection installed inside CPU will shut down the transmitter and deactivate the MAIN relay.
8. To operation normally, the battery power has to be over 2.2V. If the voltage is lower than 2.2V, the system cannot be started and low voltage will be showed until the MAIN is completely shutdown.
9. If the power voltage is lowered than 2.2V when transmitter is operated, the LV code will be “1” and low voltage status light will be shown. The transmitter will stop sending signals when voltage is lower than 2.0V.

Power status
light

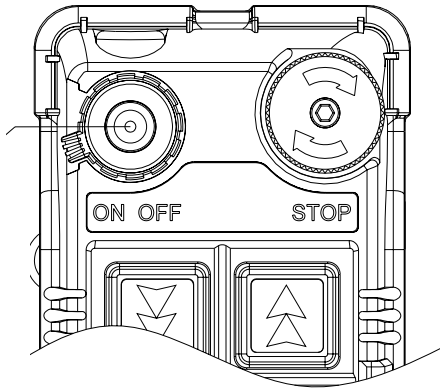

STOP: press → lock (emergency stop)

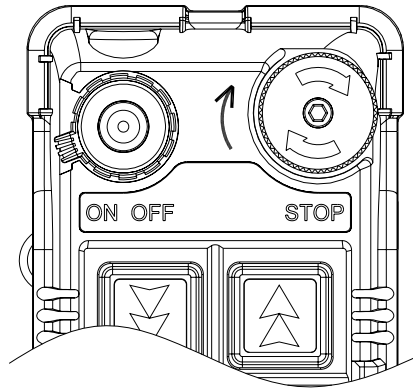

STOP: Elevate clockwise → reset (Turn on the transmitter at any time)

8.2 Transmitter Status Light

Type	Status	Solution	LED Indication
1	Charging	Place transmitter into charger	Red light ON
2	Power on when voltage is low	BATT<2.2V	Red light flash ON_0.1/OFF_1.9 sec (until power off)
3	Setting failed or invalided	Set data by using JUMPER & dip-switch without following rules	Red light ON_0.1/OFF_0.1 sec
4	Setting completed	JP1 or JP2 inserted	Green light ON until power off.
5	EEPROM ID error	EEPROM ID code does not match CPU	Red light ON until power off
6	RF module abnormal	PLL UNLOCK	Red light ON_0.1/OFF_0.1 sec
7	ID even number error	Setting error	Red light ON_1/OFF_1 sec
8	Pushbutton locked	Power on pushbutton connected	Red light ON_1.9/OFF_0.1 sec (until power off)
9	Normal power on	BATT>=2.2V and all the pushbuttons are not depressed	All the lights ON_2 sec
10	STOP status	STOP button is pressed	MODE 0: Red light ON_0.5/ OFF_0.5sec, flash 30sec. MODE 1: all the lights OFF
11	Low voltage during operation	BATT<2.2V and press pushbutton	Red light flash ON_0.1/OFF_1.9sec
12	Normal operation	Press pushbutton	Green light flash ON_0.1/OFF_1.9 sec

9. RECEIVER INSTALLATION

9.1. Preparation for Installation

1. Required Tools for Receiver Installation:
 - (1) Flat Head Screwdriver (-)
 - (2) Phillips Head Screwdriver (+)
 - (3) Multi-Meter
 - (4) 14mm Wrench x 2
 - (5) Power Drill with φ 10.5mm Drill-Bit
2. Check to ensure that your receiver is not set to the same RF channel and ID code as any other systems in operation at the same facility or within 300-meter distance.
3. Prior to installation, make sure that the crane or equipment itself is working properly.
4. Use a multi-meter to check the voltage source available and ensure the receiver voltage setting matches your power source.
5. Prior to installation, switch off the main power source to the crane or equipment.

9.2 Step By Step Installation

1. For better reception, the location selected should have the antenna visible from all areas where the transmitter is to be used.
2. The location selected should not be exposed to high levels of electrical noise. Mounting the receiver next to an unshielded variable frequency control (inverter) may cause minor interference. Always locate the receiver unit as far away from inverter controls as possible.
3. Ensure the selected location has adequate space to accommodate the receiver enclosure.
4. Make sure the receiver unit is in upright position (vertical).
5. The distance between the antenna and the control panel should be as far apart as possible (refer to the fig. on page 22).
6. If a crane or equipment's runway is longer than 100 meters, an external antenna should be added. The Alpha 608 receiver housing has provisions for an external factory installed antenna available as an option, contact your dealer for price and delivery.
7. Drill a hole on the control panel (10.5mm).
8. Tightened the bolt nuts provided.
9. **If the control panel has a plastic surface, extended grounding wire should be used.**
10. For system wiring, please refer to the output contact diagrams from page 4.
11. Ensure all wiring is correct and safely secured and all screws are fastened.

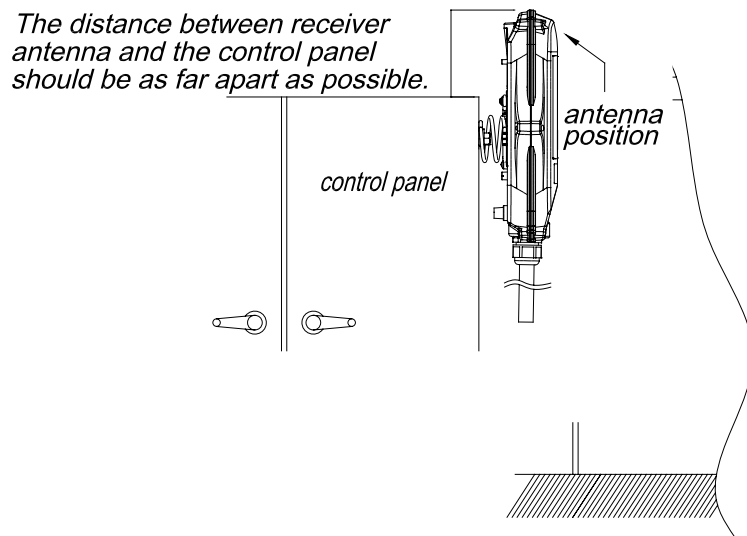

(Fig. 21) Alpha 604, 607, 608 Models

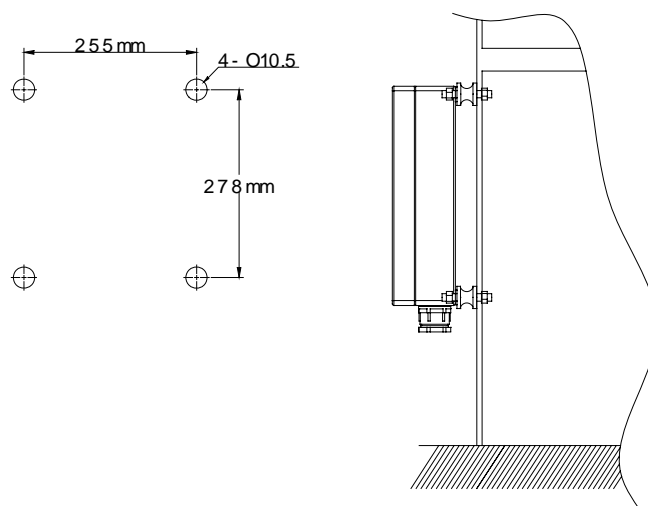

(Fig. 22) Alpha 612 Models

9.3 System Testing

1. Connect the power source to the receiver and test the MAIN relay output by pressing the red emergency stop button (EMS) and observe that it properly opens and closes the main line disconnect contactor.
2. Test the operation of each function to ensure it corresponds to the transmitter direction labels and/or the pendant it is replacing.
3. Test the limit switches on the hoist and/or crane and verify they are working properly.
4. If your new remote control is replacing an existing pendant, make sure it is completely disconnected to prevent unwanted control commands, i.e. snick circuits.
5. If your new remote control is replacing an existing pendant make sure it is stored in a safe location where it will not interfere with remote operation (get torn off).

9.4 Receiver system Status LED Display

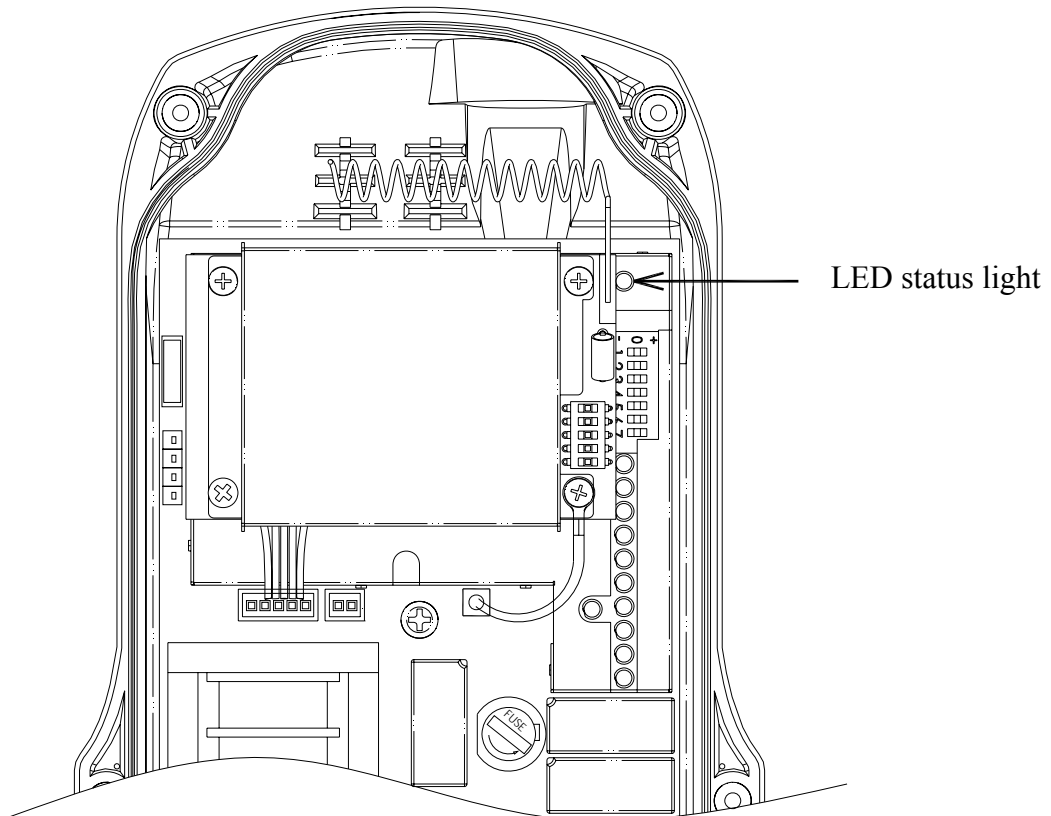

Receiver system Status LED Display

Type	Led Indication	Problem and Solution
1	Constant red light.	EEPROM error – reprogramming required.
		Incorrect receiver ID code setting (see note below).
2	ON → 1.0 second OFF → 1.0 second	ID code not matched on both the transmitter and receiver unit, please readjust accordingly.
3	Dim or no light.	Under-voltage, check the main power-supply.
4	ON → 2.0 seconds OFF → 0.1 second	MAIN contact relay jammed or defective.
5	ON → 0.1 second OFF → 2.0 seconds	System normal with transmitter pushbutton either in neutral or in transmitter power “off” position.
6	ON → 0.1 second OFF → 0.1second	System normal with transmitter pushbutton in non-neutral position (pushbutton depressed).

Note: Please refer to section 7.2 on page 22 for correct ID code setting.

9.4.1 Alpha 612 Receiver System Status LED Display

Led Indication		Reason	Solution
Power LED display	ON	Normal-voltage	
	OFF	Under-voltage	
SQ, Status LED display	ON	Transmitted signals detected and received	
	OFF	No transmitting signal detected	
	BLINK	1. Transmitter standby	Turn on the transmitter
2. Interference		Turn off the transmitter	
Relay LED display	ON	Normal operation	
	OFF	Receiver defective	Repair decoder board

10. TROUBLE SHOOTING

Should the operator find the equipment not operating normally, please check the chart below for simple trouble shooting tips.

Problem	Possible Reason	Solution
Transmitter does not communicate with the receiver.	Transmitter and the receiver are not on the same RF channel (SQ lamp not lit) or ID code.	Ensure the correct transmitter is in use. The labels on the receiver and the transmitter will identify the RF channel and ID code in use.
Transmitter does not communicate with the receiver.	Low or no transmitting power from the transmitter unit.	Turn “on” the transmitter with EMS elevated. If the status LED shows blinking red light or no light at all, then turn the power “off” and replace the two alkaline “AA” batteries.
No power to the receiver (AC power indicator on the receiver unit not lit).	Blown fuse or no input power connection.	Ensure power input to the receiver unit is correct. If the power indicator (AC) is still not lit, please check the receiver for any open fuse.
Outputs do not operate correctly.	Receiver configuration is not set properly or output wiring is incorrect.	Please refer to section 6 and 7 to ensure receiver is correctly wired and configured for your application.
Transmitter does not communicate with the receiver.	Transmitter is turned on with the EMS activated (pressed down).	Elevate the EMS first and then turn the power switch off and then on again.

11. SYSTEM SPECIFICATION

Transmitter Unit

Frequency Range	:	433 MHz
Transmitting Range	:	100 meters
Hamming Distance	:	6
Channel Spacing	:	25KHz
Frequency Control	:	Quartz Crystals
Frequency Drift	:	< 5ppm @ -25°C ~ +75°C
Frequency Deviation	:	< 1ppm @ 25°C
Spurious Emission	:	- 50dB
Transmitting Power	:	~1mW
Emission	:	F1D
Antenna Impedance	:	50 ohms
Enclosure Rating	:	IP-66
Source Voltage	:	3.0V ("AA" alkaline batteries x 2)
Current Drain	:	10 ~ 18mA
Operating Temperature	:	-25°C ~ +75°C
Dimension (607~608 Models)	:	172mm x 68mm x 33mm
(612 Models)	:	235mm x 68mm x 30mm
Weight (607~608 Models)	:	300g (include batteries)
(612 Models)	:	350g (include batteries)

Receiver Unit

Frequency Range	:	433 MHz
Channel Spacing	:	25KHz
Hamming Distance	:	6
Frequency Control	:	Synthesizer (PLL)
Frequency Drift	:	< 5ppm @ -25°C ~ +75°C
Frequency Deviation	:	< 1ppm @ 25°C
Sensitivity	:	-120dBm
Antenna Impedance	:	50ohms
Data Decoder Reference	:	Quartz Crystals
Responding Time	:	40ms (Normal)
Enclosure Rating	:	IP-65 (Alpha 500~560 Models) IP-66 (Alpha 580 Models)
Source Voltage	:	AC 220V ~ 230V @ 50/60 Hz.
Power Consumption	:	11VA
Operating Temperature	:	-25°C ~ +75°C
Output Contact Rating	:	250V @ 10A
Dimension (607~608 Models)	:	310mm x 134mm x 72mm
(612 Models)	:	300mm x 236mm x 80mm
Weight (607~608 Models)	:	2,000g (include output cable)
(612 Models)	:	3,400g (include output cable)

12. PARTS LIST

Transmitter

	Part No.
1. Encoder board (Alpha 607A)	BEN607A
Encoder board (Alpha 607B)	BEN607B
Encoder board (Alpha 607AT)	BEN607AT
Encoder board (Alpha 607BT)	BEN607BT
Encoder board (Alpha 608A)	BEN608A
Encoder board (Alpha 608B)	BEN608B
2. Transmitter enclosure (A607 & Alpha 608)	BCT607
3. Battery cover	BC600
4. 2-step pushbutton	B50001
1-step pushbutton	B50002
5. Pushbutton rubber fixing holder	BCH608
6. Pushbutton rubber boot (Alpha 607 & 608)	PRB02
7. Transmitter shock-absorbing rubber (Alpha 607 & 608)	SAR02
8. Transmitter vinyl protective cover (Alpha 607 & 608)	VPC02
9.EMS pushbutton	B50003
10. EMS red cap (all models)	EMS01
11. A600 waist strap	WS01
12. Rechargeable battery	RCB01
13. A600 pushbutton direction label	DL01

Receiver

1. Decoder board (Alpha 607A)	BDE607A
Decoder board (Alpha 607B)	BDE607B
Decoder board (Alpha 607AT)	BDE607AT
Decoder board (Alpha 607BT)	BDE607BT
Decoder board (Alpha 608A)	BDE608A
Decoder board (Alpha 608B)	BDE608B
2. 433MHz receiver RF module (All models)	BRX433
3. Receiver enclosure (Alpha 607, 608)	BCR607
4. Receiver mounting spring (Alpha 607, 608)	RMS600
5. Regular Output Contact Relay-blue (All Models)	BDE607BT
6. Safety MAIN Contact Relay-DC12V (All Models)	BDE608A
7. Transformer (12/24VDC – Alpha 600-608)	T24VDC
Transformer (24VAC – Alpha 600-608)	T24VAC
Transformer (48VAC – Alpha 600-608)	T48VAC
Transformer (110/120VAC – Alpha 600-608)	T120VAC
Transformer (220/230VAC – Alpha 600-608)	T230VAC
Transformer (380VAC – Alpha 600-608)	T380VAC
Transformer (220/230VAC – Alpha 600-608)	T230VAC
8. 2-meter Output Cable with 5 Common Circuits Cable (24C*2m V3.5, Alpha 607, 608)	OC607
9. Optional External 433 MHz Antenna (All Models)	ANT433