

Product Overview:

PM1E Wi-Fi Smart Power Outlet can be controlled through Wi-Fi wireless network. You can switch on/off outlet and monitor its status wirelessly. You also can upgrade the firmware of the PM1E on LinkWise App.

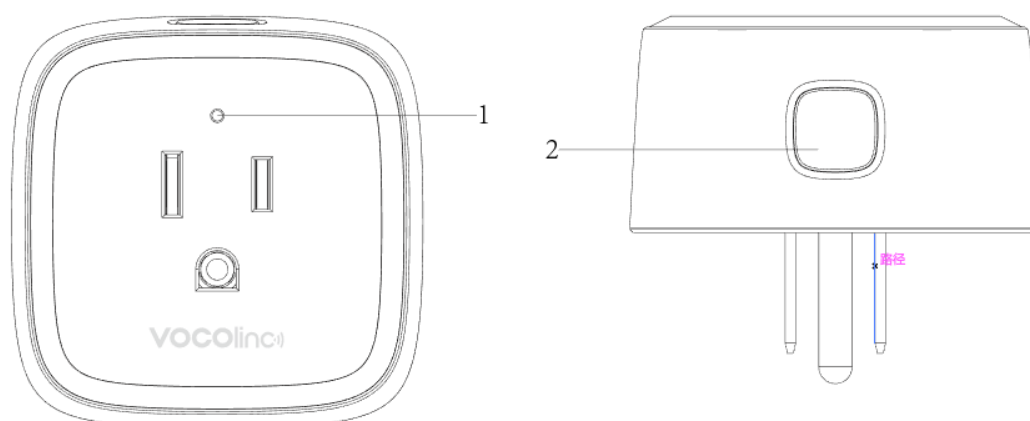

1	Status indication LED	Indicate Wi-Fi/Power status
2	Power/ Reset Button	Short Press:switching outlets on/off Press &hold for about 5 seconds: factory reset

LED Indicators Status

Status	Status indication LED status
Search Wi-Fi	Green Flashing quickly
Adding a device	Green Flashing slowly
A device added Successfully	Red flashing slowly 5 times
Identify a device	Red flashing slowly 5 times
Connected to Wi-Fi(Outlet On)	Green stay on
Connected to Wi-Fi(Outlet Off)	Indication LED stay off
Disconnected from Wi-Fi	Red flashing fastly
Reset	Press & Hold for 5s, then red flash 1 time, green flashing fastly
OTA in Progress	Red flash slowly

OTA done	Red flashing fastly 4 times
----------	-----------------------------

What's Included:

- Wi-Fi Smart Power Outlet
- User Guide

Features:

- Independent smart outlets and LED indicators
- Work with Apple HomeKit
- Can be applied to local or remote control of fans, lights, water coolers, heaters, and rice cookers etc.
- overload protection

Electrical Ratings**1 x Smart AC Outlet**

Input: AC100~120V, 60Hz

Output: AC100~120V, 10A Max, 1200W Max (Pure Resistive Load)

General use**Safety Warnings**

- Plug directly into electric outlet (not into extension cord)
- For indoor use only
- Remove Smart Plug from outlet before cleaning
- DO NOT clean with liquid
- DO NOT remove ground pin (middle pin) as there is risk of electric shock
- DO NOT use in wet or damp areas
- Keep children away from Smart Plug and outlet
- DO NOT exceed the recommended electrical ratings
- DO NOT use in precision timing applications where inaccurate timing could be dangerous
(sunlamps, saunas, etc.)
- DO NOT use with devices that should not be operated unattended.

- After switching off the the main power, DO NOT operate until the main power indicator goes completely off (about 2 seconds delay)
- DO NOT use the device when the casing is broken

Quick Start Guide

1. Download and open the free VOCOLinc LinkWise app from the App Store (Apple App Store).
2. Plug the Smart Power Outlet into a desired outlet. Press & Hold the Reset Button for about 5 seconds, the Status indication LED will start red flash 1 time, green flashing fastly to indicate it is ready for network setup.
3. Make sure your iPhone or iPad (iOS 12 or later) is connected to a 2.4GHz Wi-Fi network. Using the router utility software, shutdown 5GHz Wi-Fi networks.
4. Tap "+" on the top left corner and follow the on-screen directions to complete network setup.

Note: To add more devices (or repeat the Smart Power Outlet setup process), tap "+" and you will be prompted to scan the setup code or manually enter the setup code.

5. Then prompted select devices from the accessory list . Each accessory has an identification code, e.g., XXX-XXXXXX. Make sure the last 6 characters of the identification code is consistent with the last 6 characters of MAC on the bottom of your Smart Power Outlet and then follow the step to add the device to the Home and Room.

if the app prompts "Couldn't add XXX-XXXXXX", please refer to the first FAQ. Please keep the setup code for future use.

6. You can assign a name to your device and use this name when speaking to Siri. For example, you can name your device "printer", then launch Siri and speak "Turn on the Printer".
7. Set up customized scenes to control multiple devices with a single command. For example, if you assign the "I'm going to bed" command to the scene of turning off bedroom light, when you speak "I'm going to bed" to Siri, everything is done.

The use of a HomeKit-enabled accessory need the follow permissions:

Settings > iCloud > iCloud Drive > Turn On

Settings > iCloud > Keychain > Turn On

Settings > Privacy > HomeKit > LinkWise > Turn On

Monitor AC status

If the AC outlet insert plug, the outlet icon display a tick.

Legal Information

Apple, iPad, iPad Air, iPhone, and iPod touch are trademarks of Apple Inc., registered in the U.S. and other countries. HomeKit is a trademark of Apple Inc.

Use of the Works with Apple HomeKit logo means that an electronic accessory has been designed to connect specifically to iPod, iPhone, or iPad, respectively, and has been certified by the developer to meet Apple performance standards. Apple is not responsible for the operation of this device or its compliance with safety and regulatory standards.

Controlling this HomeKit-enabled accessory automatically and away from home requires an Apple TV with tvOS 12 or later or an iPad with iOS12 or later set up as a home hub.

To control this HomeKit-enabled accessory, iOS 12 or later is recommended.

Operation is Subject to the Following Two Conditions:

This device complies with part 15 of the FCC Rules. Operation is subject to the following two conditions: (1) This device may not cause harmful interference, and (2) this device must accept any interference received, including interference that may cause undesired operation.

Changes or modifications not expressly approved by the party responsible for compliance could void the user's authority to operate the equipment.

This device must not be co-located or operating in conjunction with any other antenna or transmitter, and must be installed and operated with a minimum distance of 20 cm between the radiator and user body.

This device complies with Industry Canada license-exempt RSS standard(s). Operation is subject to the follow two conditions:(1) This device may not cause interference, and (2) this device must accept any interference, including interference that may cause undesired operation of the device.

Cet appareil est conforme avec Industrie Canada exempts de licence standard RSS(s). Son fonctionnement est soumis aux deux conditions suivantes: (1) Cet appareil ne doit pas provoquer d'interferences et (2) cet appareil doit accepter toute interference,y compris celles pouvant causer un mauvais fonctionnement de l'appareil.