

# Model VM08

Eight Channel Digital Mixer with DSP Effects

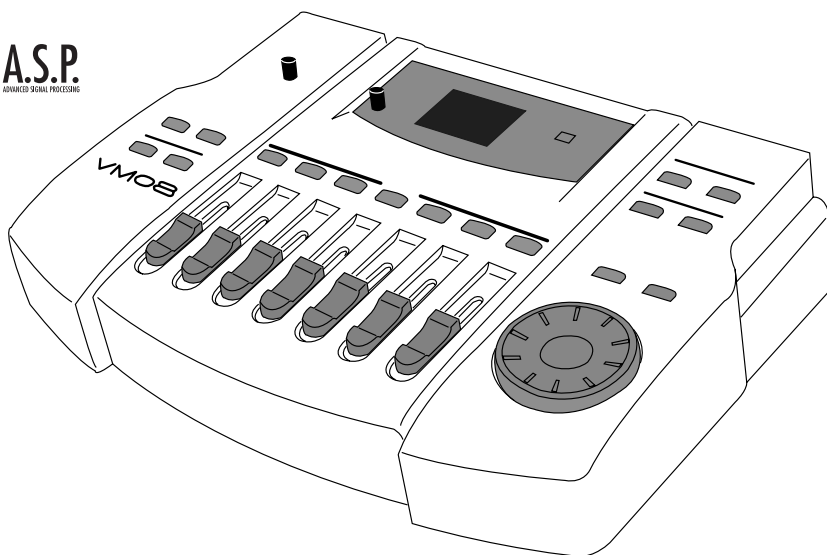

## Introduction

Thank you very much for purchasing the Fostex VM08.

The VM08 digital mini-mixer does all internal signal processing digitally.



The input section consists of eight analog input channels including four for microphones. The output section, in addition to normal analog outputs such as two channel stereo and a headphone output, also has S/P DIF digital optical output with a 44.1 kHz sampling frequency; and 20 bit quantization.

The internal buss is two channel stereo L/R, plus an independent Effects buss (1, 2) and an AUX buss (1, 2).

In addition to each input channel, an EQ is also provided for the master output. The VM08 also incorporates high performance DSP multi-effects on two channels that operate by A.S.P. (Fostex Advanced Signal Processing Technology\*) exclusively developed by Fostex. This allows a wide range of equalizing and effects processing. All settings, including mix and effects settings, are stored in scene memory, and a desired scene memory can be recalled instantaneously. Although small and lightweight, the VM08 is a high performance unit. Please read this manual carefully before operation to understand all functions of the VM08.

\* See page 18 for more details on the A.S.P. (Fostex Advanced Signal Processing Technology).

# Fostex®

 <div style="display: inline-block; background-color: black; color: white; padding: 5px; text-align: center; font-weight: bold;">CAUTION</div> 
<b>RISK OF ELECTRIC SHOCK DO NOT OPEN</b>
<p style="text-align: center;">CAUTION: TO REDUCE THE RISK OF ELECTRIC SHOCK, DO NOT REMOVE COVER (OR BACK). NO USER - SERVICEABLE PARTS INSIDE. REFER SERVICING TO QUALIFIED SERVICE PERSONNEL.</p>

**CAUTION:**  
TO PREVENT ELECTRIC SHOCK, MATCH WIDE BLADE OF PLUG TO WIDE SLOT, FULLY INSERT.

**ATTENTION:**  
POUR ÉVITER LES CHOCS ÉLECTRIQUES, INTRODUIRE LA LAME LA PLUS LARGE DE LA FICHE DANS LA BORNE CORRESPONDANTE DE LA PRISE ET POUSSER JUSQU' AU FOND.

## "WARNING"

"TO REDUCE THE RISK OF FIRE OR ELECTRIC SHOCK, DO NOT EXPOSE THIS APPLIANCE TO RAIN OR MOISTURE."

## SAFETY INSTRUCTIONS

1. Read Instructions - All the safety and operating instructions should be read before the appliance is operated.
2. Retain Instructions - The safety and operating instructions should be retained for future reference.
3. Heed Warnings - All warnings on the appliance and in the operating instructions should be adhered to.
4. Follow Instructions - All operating and use instructions should be followed.
5. Water and Moisture - The appliance should not be used near water - for example, near a bathtub, washbowl, kitchen sink, laundry tub, in a wet basement, or near a swimming pool, and the like.
6. Carts and Stands - The appliance should be used only with a cart or stand that is recommended by the manufacturer.



An appliance and cart combination should be moved with care. Quick stops, excessive force, and uneven surfaces may cause the appliance and cart combination to overturn.

7. Wall or Ceiling Mounting - The appliance should be mounted to a wall or ceiling only as recommended by the manufacturer.
8. Ventilation - The appliance should be situated so that its location or position does not interfere with its proper ventilation. For example, the appliance should not be situated on a bed, sofa, rug, or similar surface that may block the ventilation openings; or, placed in a built-in installation, such as a bookcase or cabinet that may impede the flow of air through the ventilation openings.



The lightning flash with arrowhead symbol, within an equilateral triangle, is intended to alert the user to the presence of uninsulated "dangerous voltage" within the product's enclosure that may be of sufficient magnitude to constitute a risk of electric shock to persons.



The exclamation point within an equilateral triangle is intended to alert the user to the presence of important operating and maintenance (servicing) instructions in the literature accompanying the appliance.

9. Heat - The appliance should be situated away from heat sources such as radiators, heat registers, stoves, or other appliances (including amplifiers) that produce heat.
10. Power Sources - The appliance should be connected to a power supply only of the type described in the operating instructions or as marked on the appliance.
11. Grounding or Polarization - The precautions that should be taken so that the grounding or polarization means of an appliance is not defeated.
12. Power Cord Protection - Power supply cords should be routed so that they are not likely to be walked on or pinched by items placed upon or against them, paying particular attention to cords at plugs, convenience receptacles, and the point where they exit from the appliance.
13. Cleaning - The appliance should be cleaned only as recommended by the manufacturer.
14. Nonuse Periods - The power cord of the appliance should be unplugged from the outlet when left unused for a long period of time.
15. Object and Liquid Entry - Care should be taken so that objects do not fall and liquids are not spilled into the enclosure through openings.
16. Damage Requiring Service - The appliance should be serviced by qualified service personnel when:
  - A. The power supply cord or the plug has been damaged; or
  - B. Objects have fallen, or liquid has been spilled into the appliance; or
  - C. The appliance has been exposed to rain; or
  - D. The appliance does not appear to operate normally or exhibits a marked change in performance; or
  - E. The appliance has been dropped, or the enclosure damaged.
17. Servicing - The user should not attempt to service the appliance beyond that described in the operating instructions. All other servicing should be referred to qualified service personnel.

## Table of Contents

<b>Precautions</b> .....	<b>3</b>
<b>Names and Functions</b> .....	<b>4</b>
<b>Before Operation</b> .....	<b>6</b>
Remove the insulation paper.....	6
Caution when powering ON.....	6
Reset of VM08.....	6
Internal battery for the memory back up..	6
<b>Peripheral Equipment Connection</b> .....	<b>7</b>
<b>Application Examples</b> .....	<b>9</b>
<b>Initial State of the VM08</b> .....	<b>11</b>
<b>Normal Mix Mode</b> .....	<b>12</b>
<b>Channel Parameter Edit Mode</b> .....	<b>14</b>
Setup method for PAN setting.....	14
EQ setup method.....	15
Setup method of the effect send level.....	15
Setup method of the aux send level.....	16
PRE/POST setup method.....	17
<b>Effect Edit Mode</b> .....	<b>18</b>
About the effect types.....	19
Selecting the effect type.....	20
Effect parameter settings.....	21
Muting an effect.....	21
Effect parameter details.....	22
<b>Scene Memory Mode</b> .....	<b>24</b>
Storing a scene memory.....	24
Recalling a scene memory.....	24
Level adjust.....	25
Fader adjust.....	25
Directly recalling a scene memory.....	26
Clearing a scene memory.....	26
<b>Setup Mode</b> .....	<b>27</b>
Making settings in setup mode.....	27
Details of the setup menu.....	27
Input 5/6 input setting.....	27
Input 7/8 input setting.....	27
Fader fix setting.....	28
Channel fader recall setting.....	28
Master fader recall setting.....	28
Foot switch setting.....	28
Battery check.....	28
<b>Specifications</b> .....	<b>29</b>

## Precautions (please read before use)

### Power Supply

- \* When unplugging the AC adaptor from the outlet, be sure to grasp the adaptor. Attempting to unplug it by pulling on the AC cable may damage the wiring.
- \* It is dangerous to use any power cable that is cut or frayed. If the power cable is damaged, immediately stop using it, and have it repaired.
- \* Do not plug in or unplug the AC adaptor with wet hands. Doing so may result in dangerous electric shock.
- \* Do not open the unit or touch any parts inside. Doing so may result in a dangerous electric shock, and could damage the unit.
- \* Do not let water or other liquids, flammable materials, or metal objects such as pins get in side the unit. These things may cause electric shock or short circuit the VM08, and damage it. If the VM08 should become wet, unplug the AC adaptor from the AC outlet, and contact your authorized service station.

### Location

Avoid using the VM08 in the following locations:

- \* Locations of extreme low or high temperatures, or extreme changes in temperature.
- \* Locations with excessive moisture or dust.
- \* Locations where direct sunlight falls for an extended time, or near a stove or other source of heat.
- \* Locations where electrical voltage varies.
- \* Unstable locations or where there is heavy vibration.
- \* Near strong magnetic fields (on top of a television or speaker).

# Names and Functions

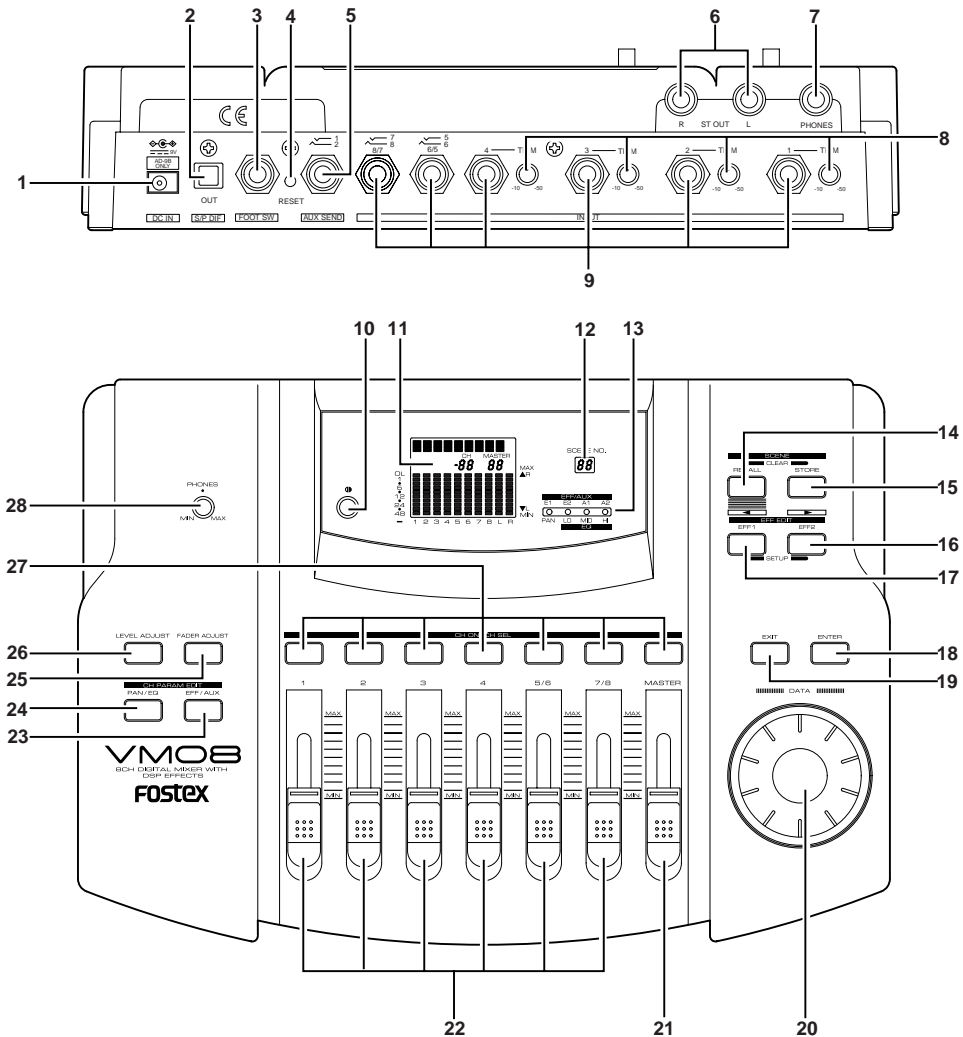

**1. AC adaptor connector**

Connect the AC adaptor, included in the accessory kit, to a wall AC socket and plug the adaptor output cable to this jack (Be sure to use the adaptor included in the VM08 package).

**2. S/P DIF optical output connector**

The same signal output from the ST OUT L/R jack is output here as digital audio signal in the S/P DIF format.

**3. Foot switch connecting jack**

A foot switch (Fostex Model 8051) is plugged in here. The foot switch function can be changed by the [SETUP mode] explained later. The initial setting recalls the scene memory. Refer to page 27 for details.

**4. RESET switch**

This switch resets the CPU inside VM08. Refer to page 6 for details.

**5. AUX send jack**

AUX SEND level signals, adjusted in the channel parameter edit mode, are output here. Refer to pages 8 and 17 for details.

**6. STEREO OUT L, R jack**

The mixed signal is output to the MTR, stereo monitor system or to other mixers. Output level is adjusted by the MASTER fader.

**7. Headphone jack**

The monitoring headphone is connected here. Use the PHONES control to adjust the sound level.

## 8. TRIM knob

Input gain is adjusted with this TRIM knob for each sound source connected to input jacks 1 ~ 4. The input level is adjustable over a wide range from line level down to mic level.

## 9. INPUT jacks

External sound sources are input here. INPUTS 1 ~ 4 comply to mic/line and input gain can be adjusted with the TRIM knob. INPUT's 5/6 and 7/8 are exclusively for line level signals.

## 10. Contrast adjusting knob

The LCD display contrast is adjusted with this knob.

## 11. LCD display

Various figures are displayed here. Refer to [Initial state of VM08] in page 11 for details.

## 12. Scene number display

The current scene number is displayed here. Refer to [Scene memory mode] on page 24 for details.

## 13. Status indicator

Using the channel parameter edit mode explained later, what is currently setup can be confirmed by the dot display. Items to be set can be selected with the PAN/EQ key or the EFF/AUX key. Refer to [Channel parameter edit mode] on page 14 for details.

## 14. Scene Recall key

This is pressed to recall the scene memory explained later. Refer to [Recall of the scene memory] on page 24 for details.

## 15. Scene Store key

This is pressed to store a scene memory. Refer to [Storing the scene memory] on page 24 for details.

## 16. Effect 2 key

This is pressed to select the EFF 2 effects type or the parameter to be edited. Also, if this key is pressed while pressing the EXIT key, muting of EFF 2 can be switched ON/OFF. Refer to [Effect edit mode] on page 18 for details.

## 17. Effect 1 key

This is pressed to select the EFF 1 effects type or the parameter to be edited. Also, if this key is pressed while pressing the EXIT key, muting of EFF 1 can be switched ON/OFF. Refer to [Effect edit mode] on page 18 for details.

## 18. Enter key

This is used to accept the current mode setting. This key will setup scene memory (page 24), the setup mode (page 27) and also the setup of effects type (page 18). Please refer to their respective explanation for details.

## 19. Exit key

This is used to exit from all modes but the normal mix mode. This key works for the channel parameter edit mode (page 14), the effects edit mode

(page 18), the scene memory mode (page 24) and the setup mode (page 27). Refer to their respective explanation for details.

## 20. Data encoder

This dial is rotated to make settings such as setup of PAN and EQ. This dial works in the channel parameter edit mode (page 14), the scene memory mode (page 24) and the effects edit mode (page 18). Refer to their respective explanations for details.

## 21. Master fader

This adjusts the master level of signal output from the STEREO OUT L, R jacks and S/P DIF OUT.

## 22. Input fader

Signal levels of sound sources connected to each INPUT jack can be adjusted with these faders. Input faders 5/6 and 7/8 controls both channels at the same time.

## 23. EFF/AUX select key

The channel parameter edit mode is entered when this key is pressed and EFFECT send output and AUX send output can be adjusted. Refer to [Channel parameter edit mode] on page 14 for details.

## 24. PAN/EQ select key

The channel parameter edit mode is entered when this key is pressed to setup of PAN and EQ. Refer to [Channel parameter edit mode] on page 14 for details.

## 25. Fader adjust key

This key warns by blinking if a fader position drifts or sound volume is accidentally changed at switch ON of power or at recall of the scene memory. Use this key to enter the fader adjust mode to manually adjust the fader position. Refer to [Fader adjust mode] on page 25 for details.

## 26. Level adjust key

This key will blink together with of the FADER ADJUST key. The level adjust mode is entered when this key is pressed so the sound level can be matched to the present fader position. Refer to [Level adjust mode] on page 25 for details.

## 27. Channel On/Channel Select key

The channel to be edited can be selected while in the channel parameter edit mode. In other modes, channel ON/OFF is possible. Refer to [Normal mix mode] on page 12 and [Channel parameter edit mode] on page 14 for details.

## 28. Headphone volume

This adjusts the monitor headphone sound volume.

## Before Operation (IMPORTANT Be sure to read below before first using your VM08.)

### \* Remove the insulation paper

The VM08 uses a memory back up battery inside. You will find a piece of insulation paper attached to avoid current dissipation. When using the VM08 for the first time, turn ON the power and then remove the insulation paper. The insulation paper is easily removed by pulling it in direction of arrow as shown at right.

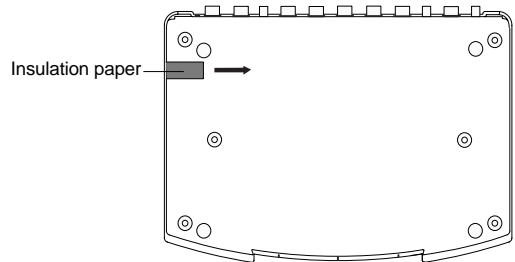

### \* Caution when powering on

There is no power switch in VM08. Power is switched ON/OFF simply by plugging and unplugging the VM08's AC adaptor plug. Be sure to switch off power to the monitor amplifier connected to the VM08 output or fully retard the input level controls to prevent damage to connected speakers when switching power ON/OFF in this manner.

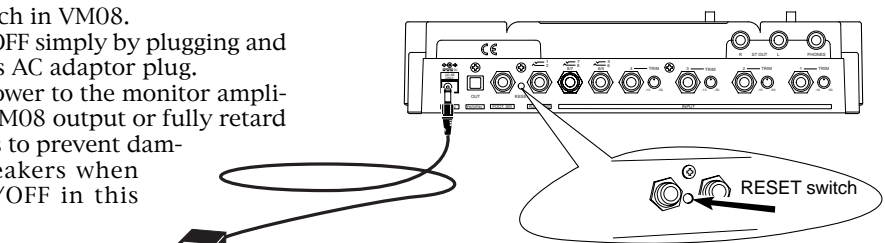

< Caution >  
If the VM08 is not to be used for a long time, be sure to unplug the AC adaptor from the wall outlet.

### \* Reset of VM08

It is possible for the computer to malfunction at power ON/OFF or by electro induction noise from lightning. In this happens, switch the power ON/OFF to the VM08 several times. If it does not return to normal operation, press the rear panel [RESET] switch with a slender ball point pen or similar tool. This returns all settings to the initial figures setup at shipping from the plant. This procedure can be used to clear all stored scene memories.

<Please remember this!>

If reset is executed with the INPUT and MASTER raised simultaneous with start up of this unit, the LEVEL ADJUST key/FADER ADJUST key will blink. This indicates that the VM08 has entered the Level Adjust Mode/Fader Adjust Mode because of the difference between present fader position and the fader position at start up following reset. To exit from this mode, retard all faders to the [MIN] position, and the key blinking will stop.

### \* Internal battery for the memory back up

The internal battery has a life expectancy of about two years. When the battery runs low and its voltage falls below a certain level, the warning message "BattEmpty" will appear in the display. If you continue to use the unit on old battery, your stored scene memories will be lost when the power is turned off. Do not try to replace the battery yourself as there are no user-serviceable parts inside. Please ask your Fostex distributor or an authorized service station to do the job.

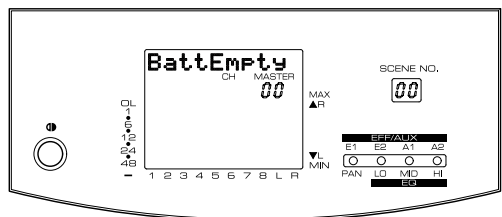

<Please remember this!>

There is an automatic internal battery voltage check function in the VM08. Refer to [Setup mode] on page 27.

## Peripheral Equipment Connection

The schematic below is an example of external equipment connected to the VM08. To avoid possible speaker damage, please be sure to unplug the AC adaptor when connecting external equipment to the IN/OUT connectors of the Fostex VM08.

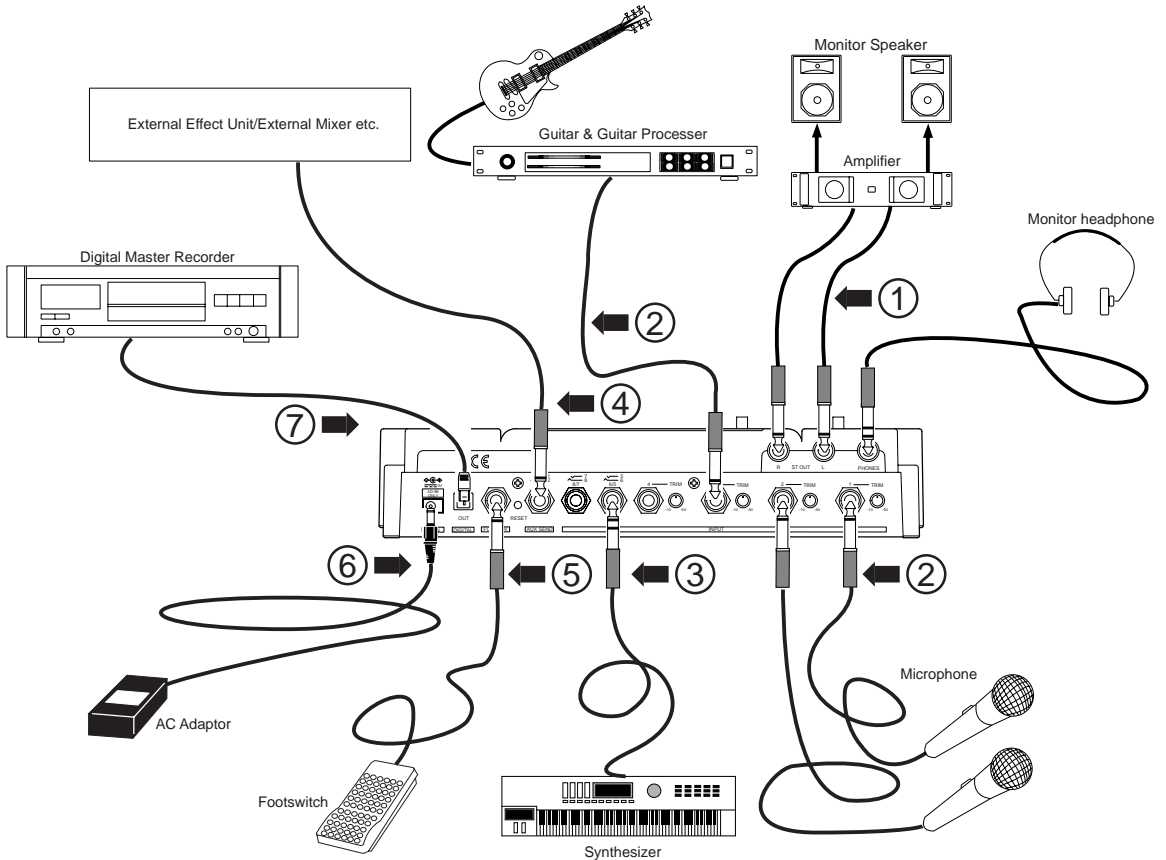

### 1) ST.OUT L, R jack

These are unbalanced phone jacks where an external monitor (amplifier+ speaker) or analog master recorder can be connected. The standard output level is -10dBV.

### 2) INPUT 1 ~ 4 jacks

These are unbalanced phone jacks for microphones and sound sources such as a guitar. TRIM knobs are provided for each jack by so input levels can be adjusted to match the sound source, from microphone input to line level signals.

### 3) INPUT 5/6 (INPUT 7/8) jacks

TRS type phone jacks for connecting line level sound sources.

As shown in the schematic, both stereo and mono output sound sources can be connected. For either type signals, the input mode can be selected using the VM08's setup mode. Refer to [Setup mode] on page 27 for setup of the input mode. Refer to next page for details in preparing and wiring the TRS phone plug. The standard input level is -6dBV.

### 4) AUX SEND 1/2 jack

TRS type phone jacks where external effects and mixers can be connected. Two channels, namely, AUX SEND 1 and 2 are output here. One or two external units can be connected. See the next page for details in preparing and wiring a TRS phone plug. The standard output level is -10dBV.

5) FOOT SW jack

This is an unbalanced type phone jack. An unlatch type foot switch (Fostex Model 8051) can be plugged in here. Operations using the foot switch are selectable in the [Setup mode]. Refer to [Setup mode] on page 27 for details.

6) DC IN connector

Plug-in the tip of the power cord of the exclusive AC adaptor (AD-9B) here and plug the adaptor into a household AC wall outlet. Since the VM08 does not have a power switch, ON/OFF of power is done by plugging and unplugging the AC adaptor from the AC wall outlet. If you don't plan on using the VM08 for some length of time, the AC adaptor must be unplugged from the AC wall outlet.

7) S/P DIF OUT connector

The same signals output from ST OUT L, R are output here as digital (S/P DIF) signals. Signals mixed in an external digital master recorder connected here can be recorded in digital as shown in the schematic. If external digital equipment to be connected is provided with only COAXIAL (RCA pin jack) type IN/OUT connectors, use the optional Fostex COP-1/96k optical-coaxial converting adaptor sold separately.

**\* INPUT 5/6 (7/8) and AUX SEND 1/2 jacks**

TRS type jacks used at INPUT 5/6, TRS type jacks used at INPUT 5/6 (7/8) and AUX SEND 1/2, and TRS phone plugs or unbalanced phone plugs can be connected here, as shown below. The phone plug should be wired as shown below.

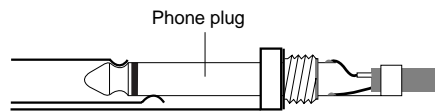
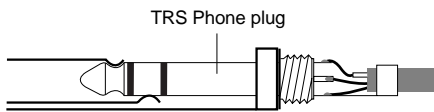

**INPUT 5/6, INPUT 7/8 jacks:**

**\* How to input a stereo signal:**

In order to input a stereo output signal to channels 5/6 or 7/8, a stereo cable with a STEREO phone plug wired as shown in the schematic should be used. Set the INPUT 5/6 input mode or INPUT 7/8 input mode in the setup mode to [Stereo]. The L signal of the stereo input signal will be applied to channel 5 (or 7) and the R signal to channel 6 (or 8). Refer to [Setup mode] on page 27 to setup the input mode.

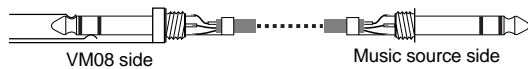

**AUX SEND OUT 1/2 jack:**

**\* Connecting two external equipment:**

Wire the TRS phone plug to two phone plugs as shown in the schematic to connect two separate pieces of equipment to AUX SEND 1/2. By doing so, the AUX SEND 1 signal and AUX SEND 2 signal will be separately output to the two.

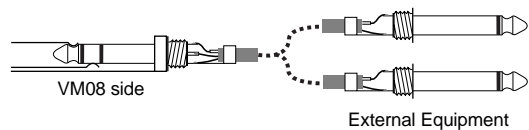

**\* How to input a monaural signal:**

In order to input a monaural output signal to channels 5/6 or 7/8, an unbalanced phone plug, as shown in the schematic, is used for the connection and the INPUT 5/6 input mode or INPUT 7/8 input mode in the "setup mode" is set to [In 5 > Mono] (or [In 7 > Mono]). The monaural signal will be simultaneously input to channels 5 and 6 (or 7 and 8). When setting the input mode, refer to [Setup mode] on page 27 for details.



**\* Connecting a single external equipment:**

In order to connect a single external piece of equipment to the AUX SEND 1/2 jack, the unbalanced phone plug is connected as shown in the schematic.

This will output only the AUX SEND 1 signal.





## Application Example

The following are actual examples in application of VM08 and could be helpful in your application.

### <Example-1> : To expand the FD-8 analog simultaneous recording channel

The FD-8 analog simultaneous recording track can be extended to "4" by connecting the FD-8 DATA IN jack to the VM08 S/P DIF OUT jack. You can also take advantage of the high quality DSP multi-effects contained in the VM08 when recording.

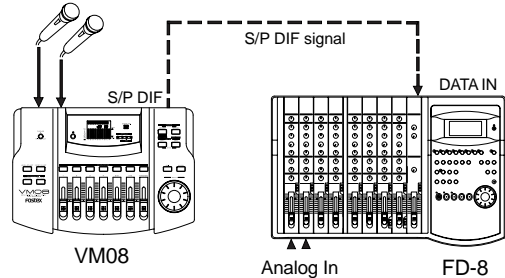

### <Example-2> : To use as a MONO IN/STEREO OUT effects

The VM08 internal DSP multi-effects can be utilized for high quality external processing by connecting the VM08 ST OUT L/R to the FD-8 AUX RTN L/R jack. If the input channel fader is set to "0" and the EFF BUSS is sent via the pre-fader, the effects sound only can be output from ST OUT.

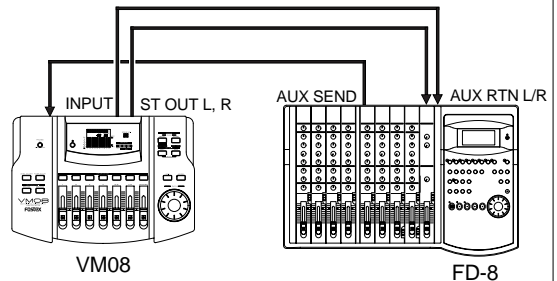

### <Example-3> : For use as a sub-mixer for a live keyboard player

The VM08 can be utilized as a sub mixer for a keyboard and sound source module. A scene memory in which the sound volume balance had been set can then be switched with the foot switch.

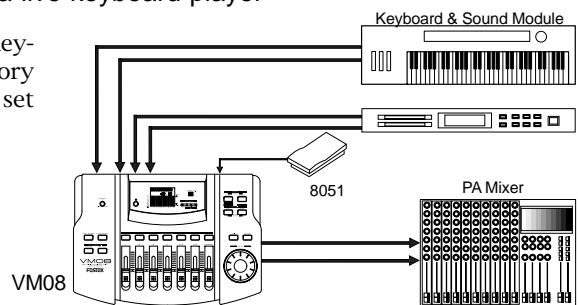

### <Example-4> : To use as a small facility mixer

In a sequence such as MC only -> MC+Music -> Music, by pre-storing the sound volume balance in the scene memory, the scene memory can be sequentially called up.

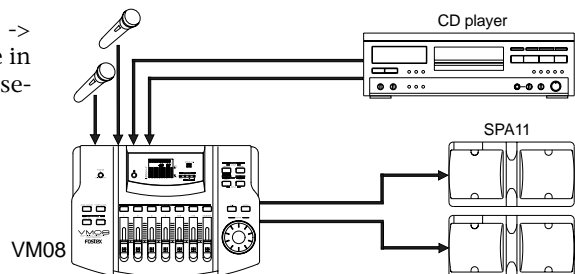

**<Example-5> : For one take live studio recording**

You can use the VM08 to send the mixed digital audio via S/P DIF to a DAT or PC with Digital In. You can also add the internal digital effect when mixing audio.

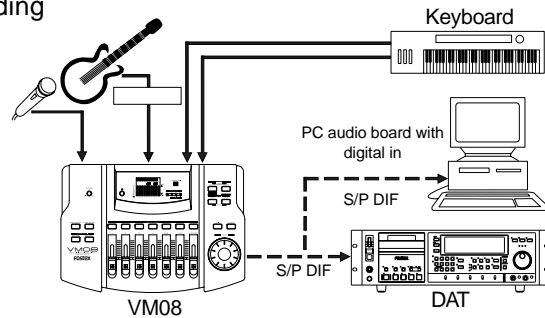

**<Example-6> : To produce original Remix**

You can send the remixed sound of the Sampler and CD player with the internal digital effect to a DAT recorder via the S/P DIF.

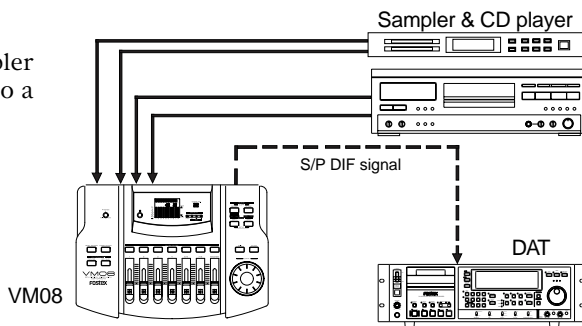

**<Example-7> : To do you own Sound Track Video Editing**

You can add your favorite background music, original sound effects and narration when editing videos.

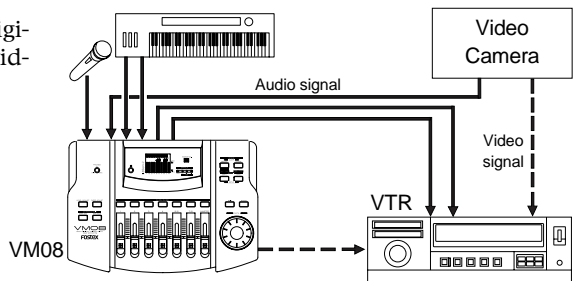

**<Example-8> : As a practice aid for your musical instruments**

You can use the VM08 to practice your musical instruments with added effects on top of backing tracks recorded on MTR's such as the X-14.

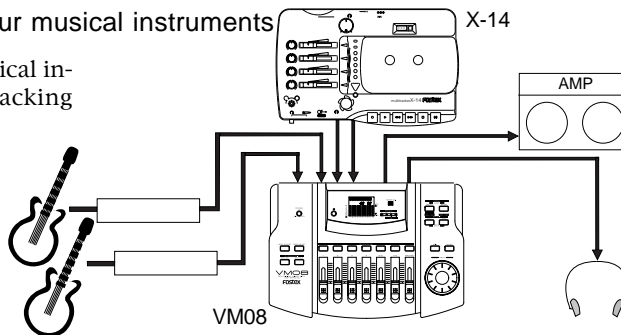

## VM08 Initial State

The following explains what to do the first time you use the VM08 right out of the shipping carton. When the AC adaptor is plugged into the AC wall outlet and the power cord plugged into the DC IN connector, power will be applied and the VM08, and the display/operating panel lamps will light in the modes explained below. This is the same as when the CPU is reset by pressing the RESET switch.

**\* Character display section:**  
Following the <<FOSTEX>> -> <<VM08>> display, [Init.Mix] will be displayed. If the INPUT fader/MAS-TER fader is manipulated in this state, [E] will be lit behind the [Init.Mix] display (Refer to next page).

**\* MASTER fader section:**  
The MASTER fader position is indicated by numbers 00 ~ 99. The initial setting is [00] which is the initial mix setting (The fader [MIN] position).

**\* Scene number display section:**  
The current active scene number (00 ~ 20) is displayed. In the initial setting, [00] will be displayed.

**\* Channel fader display section:**  
After entering the channel parameter edit mode, the INPUT fader position of the channel selected by the CH ON/CH SEL key will be indicated by numbers 00 ~ 99. In the initial state, nothing is displayed. For details, refer to [Channel parameter edit mode] on page 14.

**\* Level display section:**  
In the channel parameter edit mode and fader adjust mode, the signal level input to each INPUT jack for channels 1 ~ 8 will be indicated by the pre-fader. In other words, regardless to the INPUT fader set position, the input signal level will be constantly displayed. Because, INPUT of channels 1 ~ 4 must handle low level signals such as from a microphone, a TRIM knob is provided for each channel to adjust the gain. The best gain level can be obtained by watching this display. Channels L and R display indicates signal levels at the STEREO OUT L, R jacks but in the initial state, the level meter will not fluctuate since the MASTER fader is set to the [MIN] position. Should the input and output signal levels reach the [OL] (over load) level, the sound will be distorted, so care must be taken in adjusting the TRIM adjust/INPUT fader.

**\* Status indicator:**  
The dot selected by the channel parameter edit mode will light but nothing lights in the initial state. Refer to [Channel parameter edit mode] on page 14 for details.

**\* CH ON/CH SEL key:**  
The channel to be edited can be selected with this key in the channel parameter edit mode and, in other modes, each channel can be switched ON/OFF. In the initial state, all channels will be indicated as ON and the key LED's will all light.

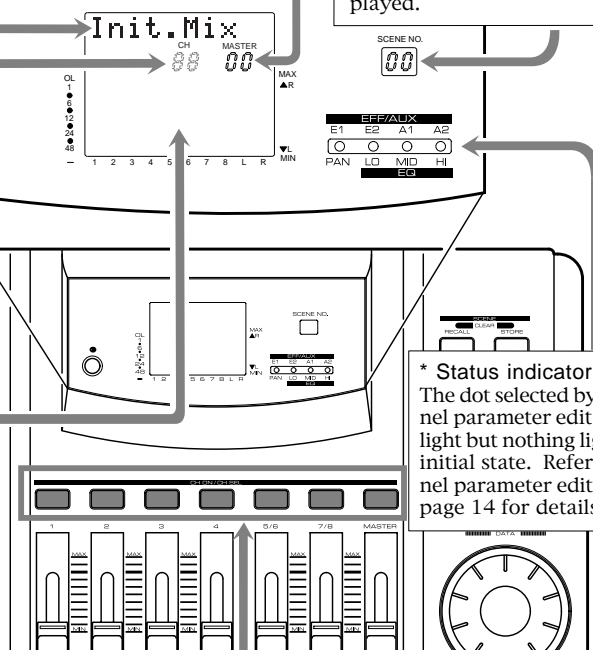

< Please remember this! >

- \* The scene number of the sber of the ssber of the scene memory which the user can setup are [00] ~ [20] but the preset scene [00] cannot be changed. Refer to page 24 for details on the scene memory.
- \* If, for some reason, you would like to return the VM08 setting to the factory default figure, refer to [Reset of VM08] on page 6.

## Normal Mix Mode

Normal mix mode means each INPUT fader/MASTER fader is active, and the ON/OFF of each channel is operational so basic mixing functions can be executed. When the VM08 is in [Initial state of VM08], as explained in the previous section, if the INPUT fader of the channel to which a signal is being input (Example: The channel 1 INPUT fader if a sound source is connected to INPUT 1.) and the MASTER fader is raised, signals will be output from the rear panel STEREO OUT L, R jacks and the S/P DIF optical connector. Also, if headphones are connected to the PHONES jack, the same signal will be heard in the headphones. The headphone monitoring sound volume can be adjusted by the top panel PHONES knob. Throughout these operation, the VM08 LCD display will change as explained below.

\* Character display section:  
[E] lights following the [Init.Mix] display. This [E] symbol means "edit" and indicates that the setting had been changed from the initial state. At this point of operation, the initial state had been changed by this moving the INPUT and MASTER faders.

\* The MASTER fader display section:  
The present position to which the MASTER fader is set will be indicated by numbers 00 ~ 99. The standard level setup number is [80].

\* Level display section:  
The input signal level will be displayed for channels 1 ~ 4, 5/6 and 7/8 and the output level in accordance to the MASTER fader position indicated by L and R.

\* Scene number display section:  
The current scene number will be displayed.

\* Status display section:  
Nothing will light up in the normal mix mode.

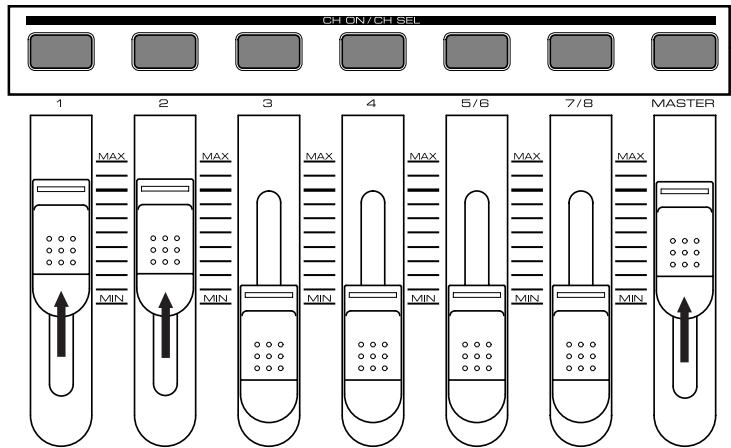
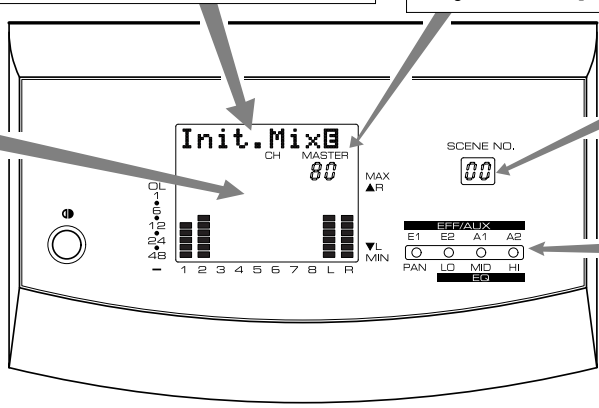

< Useful information !>  
 \* When the MASTER fader is rotated, its position will be digitally indicated in the MASTER fader section in the display and the sound volume will vary. A digital indication of the INPUT fader position will be displayed in the [Channel parameter edit mode] explained in the next section. For details, refer to [Channel parameter edit mode] on page 14.  
 \* The relationship between the actual gain and the INPUT fader and MASTER fader is, 00= -∞, 80dB=0dB, 99=+6dB.

**<CAUTION>**

If [Fader Fix mode], discussed below, in the [Setup mode] is set to [ON], no signal will be output even though the fader is moved. The [FADER FIX mode] is set to [OFF]. For details refer to [Setup mode] on page 27.

**Mute of the various input channel/master output:**

Mute ON/OFF of channels 1 ~ 4, 5/6, 7/8 and master output can be done using the CH ON/CH SEL key. Normally, the CH ON/CH SEL keys for channels 1 ~ 4, 5/6, 7/8 and MASTER are all ON (key LED is lit). Therefore, when the CH ON/CH SEL key of the channel you wish to mute is pressed, sound from that channel only will be muted (the CH ON/CH SEL key LED of the channel that was pressed will be extinguished). Mute ON/OFF alternates with each pressing of the CH ON/CH SEL key.

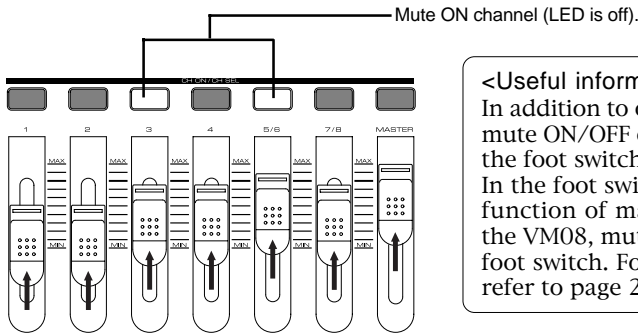

**<Useful information !>**

In addition to operating with the CH ON/CH SEL key, mute ON/OFF of master output is also possible using the foot switch (Optional Model 8051). In the foot switch functional setting is set for [Mute function of master output] in the [Setup mode] of the VM08, mute can be executed by stepping on the foot switch. For details on the [Setup mode], please refer to page 27.

**<Useful information !>**

In the normal mix mode, if the position of the INPUT fader/MASTER fader before switching off power is different from when power is switched on (refer to schematic below), the FADER ADJUST and LEVEL ADJUST key LED's (red) will flash. This is because the fader setting before switching off power is in memory, and the VM08 is indicating that fader and level adjustment is possible. The fader position can be reset to the position prior to switching off power, and the level position can be deliberately set to the present sound volume setting.

\* To return to the setting before switching off power:

Press the flashing FADER ADJUST key (It will enter the fader adjust mode). Subsequently, adjust each fader position by referring to [Fader adjust mode] explanation.

\* To set to the present fader position:

Press the flashing LEVEL ADJUST key and the VM08 will enter the level adjust mode. Then setup by following [Level adjust mode] on page 27.

If it is not necessary to match the fader positions, the FADER ADJUST key flashing will extinguished after all faders are moved and the VM08 will return to the normal mix mode.

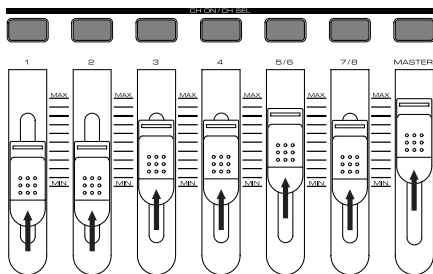

<Setting before switch off of power>

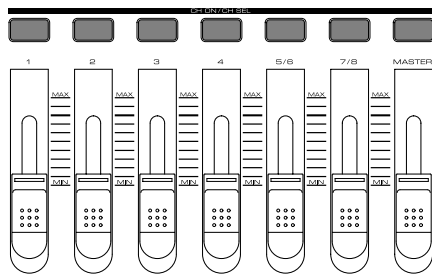

<Setting at switch on again of power>

## Channel Parameter Edit Mode

Twelve items, as shown in list below, can be set by the channel parameter edit mode. Regardless of the VM08's current mode, their respective edit modes can be entered by executing the key operations listed below. To exit from the channel parameter edit mode, press the EXIT key.

Setting Item	Executing Key	Changing the channel	Changing the setup content
Setup of PAN (sound image)	When the PAN/EQ key is repeatedly pressed, the setup item will alternately switch. In the initial state, the channel 1 PAN setup will be displayed.	Channel 1 is selected in the initial state and the channel to be edited is selected by pressing each respective CH ON/CH SEL key. The CH ON/CH SEL key LED (green) of the selected channel will blink.	Setup is changed by utilizing the DATA encoder.
Setup of LO-EQ			
Setup of MID-EQ			
Setup of HI-EQ			
Level setup of EFF SEND 1	When the EFF/AUX key is repeatedly pressed, the setup item will alternately switch. In the initial state, the channel 1 EFF SEND 1 level setup will be displayed.		
Level setup of EFF SEND 2			
Level setup of AUX SEND 1			
Level setup of AUX SEND 2			
PRE/POST setup of EFF SEND 1	If the EFF/AUX key is pressed while pressing on the EXIT key, the setup item will alternately switch.		
PRE/POST setup of EFF SEND 2			
PRE/POST setup of AUX SEND 1	In the initial state, the display will be PRE/POST setup of channel 1 EFF SEND 1.		
PRE/POST setup of AUX SEND 2			

**<Useful Information!>**

When selecting a desired item, each time the respective key is pressed, it will move to the next item, and if the key is held down, it will change one item backward in the setup item list.

### Setup method for PAN setting

Balance of channels 1 ~ 4, 5/6, 7/8 and STEREO MASTER signals must be setup.

1. Press the PAN/EQ key to light up the [PAN] dot in the status display section.  
The LCD will display the following:

\* Character display section:  
[1-Pan: C] will be displayed. Now PAN of channel 1 can be setup, and this indicates that the present PAN setting is for centering the sound image (C).

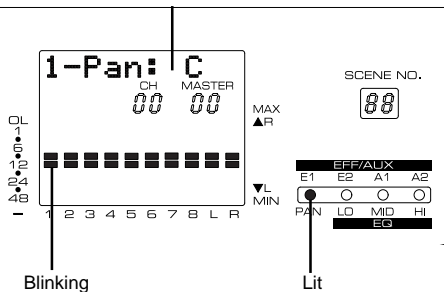

3. The number is adjusted with the DATA encoder. The number can be changed within the range of [L10] ~ [C] ~ [R10] and the sound image position will change accordingly. The graphic display will also change at the same time.

[L10] ~ [L1] ~ [C] ~ [R1] ~ [R10] will be displayed.

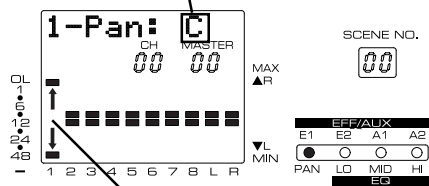

The digit moves up and down.

**<Useful information!>**

When the DATA encoder is activated to set PAN, its position will be displayed digitally in 21 steps within the range of [L10] ~ [C] ~ [R10] but the actual change in sound will be continuous (smooth). If channels 5/6 and 7/8 had been selected, balance between the two channels can be setup. If the MASTER had been selected, balance between L and R can be setup.

## Setup method for EQ setting

Individual setup of the low region (LO), mid region (MID) and high region (HI) for the signals of channels 1 ~ 4, 5/6, 7/8 and STEREO MASTER.

**<Useful information!>**

The equalizer specs of VM08 are, 100Hz +/- 18dB (shelving type) for LO-EQ, 1kHz +/- 18dB (peaking type) for MID-EQ, and 10kHz +/- 18dB (shelving type) for HI-EQ. Each can be adjusted in 1dB steps.

1. [LO], [MID] or [HI] dots in the status display section will light by successively pressing the PAN/EQ key.  
The LCD display will show the following:

Example: Character display section when [LO] is made to light.  
[1-LO: 0] will be displayed. In this condition, LO-EQ of channel 1 can be adjusted and is the indication that the present LO-EQ setting is flat (0dB).

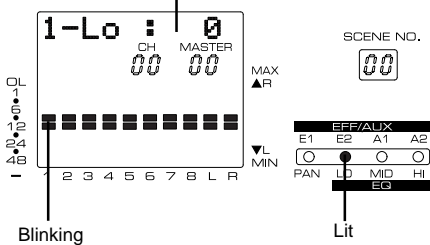

2. The channel you wish to adjust is selected by pressing the desired CH ON/CH SEL key. The selected channel CH ON/CH SEL key will blink.

3. The number is set with the DATA encoder. The number will change in the range of [-18dB] ~ [+18dB] and the equalized sound will also change. The graphic display will also change at the same time.

[+18] ~ [+1] ~ [0] ~ [-1] ~ [-18] will be displayed.

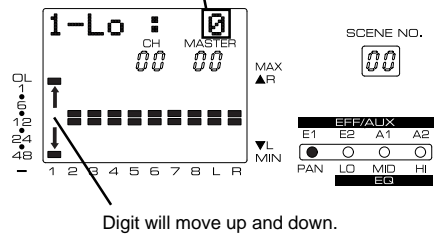

**<Useful information!>**

When channels 5/6 and 7/8 are selected, the two channels will be simultaneously equalized. If MASTER is selected, both L and R will be equalized at the same time.

## Setup method of the EFFECT SEND level

In the following, the effects send level of the signal in the channel to which effects is to be applied is adjusted before sending it to the DSP multi-effects (EFF 1/EFF 2) contained in the VM08. It is also possible for the effect send signal to select either POST (post fader) or PRE (pre-fader). The VM08 is set to POST (post fader) in the initial state.

**<Useful information!>**

- \* The EFFECT SEND signal adjusted in channels 1 ~ 4, 5/6 and 7/8 is sent to the VM08 internal DSP multi-effects (EFF1 or EFF 2). The operating explanation used here is based on the effects type ([Norm. HALL] in EFF 1, [CHORUS] in EFF 2) which are preset in EFF 1/EFF 2. Twenty-eight preset effects for EFF 1 and 38 types for EFF 2 are provided in the VM08. To select other effects or adjust effect parameters, refer to [Effect edit mode] on page 18.
- \* Because EFFECT SEND is set in the post fader (the signal controllable by the INPUT fader) in the initial state, in this explanation it is necessary for the INPUT fader to be raised on the channel in which the EFFECT SEND level is to be adjusted. In addition, the MASTER fader to adjust output level from ST OUT L, R is also raised. To setup of the EFFECT SEND PRE/POST, see page 17.

- Status display section [E1] or [E2] dots are lit by pressing the EFF/AUX key. The LCD will display the following:

Example: Character section when [E1] is lit. [1-Eff1:00] is displayed. Channel 1 EFFECT SEND 1 level can now be adjusted. The present EFFECT SEND 1 level setting is "dry" (0).

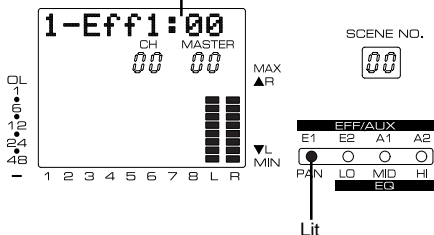

- Select the channel to be adjusted by pressing the desired CH ON/CH SEL key.

- Adjust the number with the DATA encoder. The number will change in a [0] ~ [99] range and the depth of effects will also change. The graphic display will change at the same time.

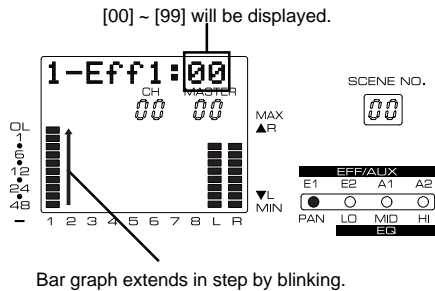

**<Useful information!>**

If channels 5/6 or 7/8 are selected, the two channels will be set at the same time. If MASTER is selected, the effect send level master can be adjusted and the L, R meter used to indicate the level.

## Setup method of the AUX SEND level

Adjusting the signal level output from the VM08 rear panel AUX SEND jack (1/2). The adjusted signal is sent to external equipment (external effects and monitor amplifier) from the AUX SEND jack. The same as with the EFFECT SEND signal, either POST or PRE can be selected for the AUX SEND signal. The VM08 is set to POST in the initial state. To change the setting, please see below [Setup of PRE/POST].

- Light up the [A1] or [A2] dots in the status display section but pressing the EFF/AUX key. The LCD will display the following:

Example: The character display section with light up [A1]. [1-Aux1:00] is displayed. Now, channel 1 AUX SEND 1 level can be adjusted. This also indicates that the present AUX SEND 1 level setting is MIN (00).

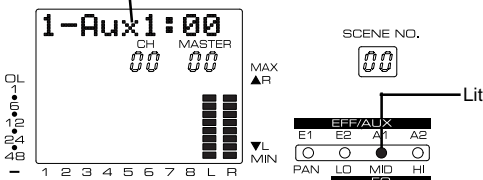

- Press the desired CH ON/CH SEL key and select the channel you wish to adjust.

- Adjust the number with the DATA encoder. The number will change in the [0] ~ [99] range and depth of effects will also change. The graphic display will change at the same time.

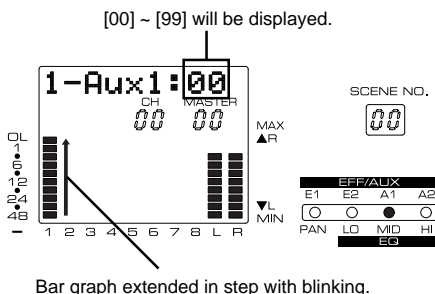

**<Useful information!>**

When channels 5/6 or 7/8 are selected, the two channels will be set at the same time. If MASTER is selected, the effect send level master can be adjusted and the L, R meter used to display the level.



## PRE/POST setup method for EFFECT SEND/AUX SEND

In the procedure here, the effect send and AUX send signals are setup for PRE (pre-fader) or POST (post fader). In the initial state, EFFECT SEND 1, 2, AUX SEND 1, 2 are all setup for POST (post fader).

**<Useful information!>**

PRE (pre-fader) means that the signal is obtained before the INPUT fader and is not affected by the INPUT fader. POST (post fader) means that the signal is obtained following the INPUT fader and is affected by the INPUT fader. In other words, in the PRE setting, although the INPUT fader is at MIN, the EFFECT SEND or AUX SEND levels can be adjusted but in the POST setting, no signal can be sent if the INPUT fader is at MIN.

1. While pressing the EXIT, press the EFF/AUX key to light up [E1], [E2], [A1] or [A2] in the status display section.  
The LCD will display the following:

Example: The character display section with [E1] is lit  
[1-E1: Post] is displayed. Now, channel 1 EFFECT SEND 1 PRE/POST can be setup. This indicates that the present EFFECT SEND 1 PRE/POST is set at POST.

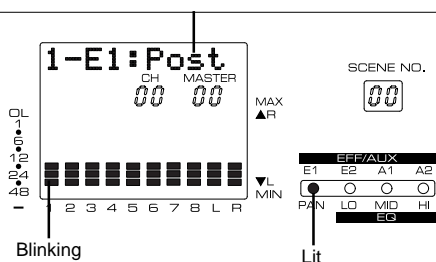

2. Press the desired CH ON/CH SEL key and select the channel you wish to adjust.

3. Adjust the number with the DATA encoder. [Pre] or [Post] can be selected. The graphic display will also change at the same time.

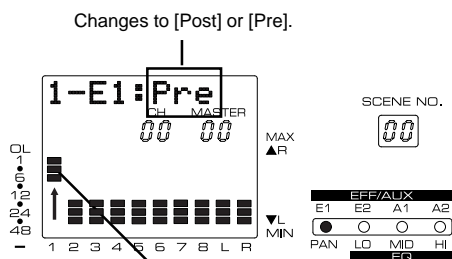

If [Pre] is selected, the blinking 3 digits move upward.

**<Useful information!>**

When channels 5/6 or 7/8 are selected, the two channels will be set at the same time. If MASTER is selected, all channels will be at the same time.

## Effect Edit Mode

The VM08 offers high quality ambient effects by employing the A. S. P. (Fostex Advanced Signal Processing Technology), which is exclusively developed by Fostex. With the A. S. P., you can obtain an incomparably clean and high density Hall Reverb, overwhelmingly clear Room Reverb and wonderfully hi-fidelity Plate Reverb. In addition to these typical Reverbs, the VM08 provides not only various practical algorithms such as Delay, Chorus, Flanger and Pitch Bend, but some combinations of these are also available, e.g., Delay+Reverb.



### \* A. S. P. (Fostex Advanced Signal Processing Technology)

The A. S. P. is an exclusive new digital effect processing technology designed by Fostex. This method extracts maximum efficiency from the limited DSP power. It achieves an overwhelmingly high density Early Reflection sound and wonderfully smooth High Dump response through the H. F. A. (Harmonic Feedback Algorithm). Also, it carries out an elaborate reverb simulation with clear sounds through the H. D. L. P. (Hi-Density Logarithmic Processing), which eliminates the mutual interference between the numerous integrated delay modules and reduce the impurity and girt of the sound.

### \* H. F. A. (Harmonic Feedback Algorithm)

There is one of indispensable elements in the natural echo called "Early Reflection Sound," which is usually sacrificed in commercial reverb products in order to reduce costs. (In practice, the Early Reflection Sound means the very first reverberated sound that bounces back from walls, floors and ceilings of concert halls). The entire reverb sound quality depends on this Early Reflection Sound and how closely it can resemble the real echo. The H. F. A. is an algorithm that enables the effect unit to reproduce a clear and natural Early Reflection Sound by applying an ideal harmonic feedback to each delay module.

### \* H. D. L. P. (Hi-Density Logarithmic Processing)

The reverb sounds consist of lots of small delay elements combined in a complex way, which are produced by many delay modules inside the effect unit. In order to obtain smooth and comfortable reverb sounds, it is very important to efficiently organize the relationship between each delay module and minimize negative mutual interference. The H. D. L. P. is a technology which applies efficient logarithmic processing to each delay module, so that they can work in the most efficient way in order to eliminate harmful reverb elements and roughness. This makes it possible to establish high density and transparent sounds.

Before the partial operation, we will briefly discuss the effect functions here such as Reverb, Delay, Chorus, and Flanger, which are integrated in the VM08.

#### **Reverb:**

The so called Reverb effect consists of various reflection sounds mixed together. For example, when you clap your hands in a tunnel, you will hear the sound linger even after you stop clapping your hands. This is the Reverb.

The sounds we normally hear in daily life have three types of sounds mixed together, i.e., "Direct sound," "Early Reflection sound" and "Late Reflection sound." The Direct sound means the sound directly reaches the ears from the sound source. The Early Reflection sound means the sound that comes after the Direct sound and has rebound off the wall of the tunnel up to a few times. The Late Reflection sound means that the sound rebounds many times long after the Direct sound has disappeared. Our ears normally hear the "Direct sound" - "Early Reflection sound" - "Late Reflection sound" in the order.

#### **Delay:**

This is the effect to added a delayed sound to the original sound. You can obtain a richer sound or completely change the original source sound by using the Delay.

#### **Chorus:**

This makes the one original sound appear to have many sources. The Chorus is used to widen or thicken the original sound.

#### **Flanger:**

The Flanger is one of applications of the Delay. This is used to create a sound like a jet airplane ascending or descending.

## About the effect types

The VM08 contains two independent DSP multi-effect units; EFF 1 and EFF 2.

A variety of effect types are preset for each effect unit. By selecting a suitable effect type, you can process the sound as you wish. You can also edit the parameters of the selected effect type to create your own effect sounds.

The following 28 effect types are preset for EFF 1. The 38 effect types shown on the next page are provided for EFF 2, and these include the same 28 effect types as EFF 1.

### Effect types preset for EFF 1

	Name	Parameter type	Explanation
1	Norm HALL	REVERB	Standard hall reverb; detailed and transparent, with a moderate amount of early reflections.
2	Pres HALL	REVERB	Hall reverb with presence and definition.
3	Wet HALL	REVERB	Hall reverb with restrained high-frequency and a refreshing atmosphere.
4	NoER HALL	REVERB	All-purpose hall reverb with no early reflections, and even decay of all frequencies.
5	Lo-F HALL	REVERB	Hall reverb with lingering low-frequency reverberation.
6	STADIUM	REVERB	Stadium reverb characterized by long early reflections.
7	Auditorium	REVERB	Reverb simulating an auditorium with suppressed reverberation.
8	Space HALL	REVERB	Reverb with a long pre-delay, creating the impression of an extended space.
9	Norm ROOM	REVERB	Room reverb simulating a moderate space with some sparkle.
10	Dead ROOM	REVERB	Room reverb simulating a narrow and dead room. Adding a slight amount will give warmth to the sound.
11	Pres ROOM	REVERB	All-purpose room reverb, with good definition and few early reflections.
12	DrumBOOTH	REVERB	Room reverb simulating a drum booth.
13	GARAGE	REVERB	Room reverb simulating a narrow and live space like a garage, with crisp presence.
14	NormPLATE	REVERB	Modern-sounding plate reverb with wide bandwidth.
15	Old PLATE	REVERB	Standard plate reverb with the character of older plate units.
16	PresPLATE	REVERB	Plate reverb with good definition and extended high-frequencies.
17	Wet PLATE	REVERB	Plate reverb with a gentle character.
18	DigiPLATE	REVERB	Plate reverb that emphasizes a digital character, with metallic early reflections.
19	NormVOCAL	REVERB	All-purpose hall reverb with no early reflections, and uniform decay at all frequencies.
20	PresVOCAL	REVERB	Short reverberation with extended high frequency is added to the early reflections of an ideal vocal booth. Since this adds sparkle to the sound, it is effective when you wish to bring the vocal to the forefront.
21	SoloVOCAL	REVERB	Plate-like reverb is added to a spacious short delay. This blends well with any genre of music.
22	Arena VOC	REVERB	Gentle reverb is added to spacious stadium-type early reflections.
23	Arena CHO	REVERB	Short reverb with extended high frequency is added to spacious stadium-type early reflections. Effective on chorus parts.
24	KARAOKE	REVERB	All-purpose reverb (karaoke style) that makes any vocal sound professional.
25	MnDL-HALL	DLY+REVERB	A combined effect of mono delay and hall reverb.
26	MnDL-PLT	DLY+REVERB	A combined effect of mono delay and plate reverb.
27	PnDL-HALL	DLY+REVERB	A combined effect of panning delay and hall reverb.
28	PnDL-PLT	DLY+REVERB	A combined effect of panning delay and plate reverb.

Effect types preset for EFF 2

	Name	Parameter type	Explanation
1 ~ 28	1-28 are the same effect types as the EFF 1 presets listed on the preceding page. (For details refer to the preceding page.)		
29	MonoDELAY	DELAY	Mono delay
30	PanDELAY	DELAY	Panning delay
31	MonoBpmDL	BPM DELAY	Mono delay. Specify BPM and note value to set the delay time.
32	PanBpmDL	BPM DELAY	Panning delay. Specify BPM and note value to set the delay time.
33	Short DL	SHORT DELAY	Short delay that allows you to set the delay time precisely.
34	DOUBLING	DOUBLING	Doubling that allows you to set separate delay times for L and R.
35	CHORUS	CHORUS	Produces a chorus effect. A doubling effect can also be added.
36	FLANGE	FLANGE	Produces a flanging effect.
37	MonoPITCH	MONO PITCH	Pitch shift adjustable in a +/-2 octave range.
38	DlyPITCH	DELAY PITCH	Pitch shift with a feedback delay, allowing strange effects to be produced.

Selecting the effect type

Here's how to select the effect type for EFF 1 or EFF 2.



- \* As described earlier in "Normal mix mode," raise the INPUT fader of a channel to which a signal is being input and raise the MASTER fader, so that the sound is heard at an appropriate level.
- \* As described earlier in "Setting the effect send level," raise the EFF 1 SEND level or the EFF 2 SEND level for the channel(s) to which you wish to apply the effect.

1. If you wish to set EFF 1, press the EFF EDIT mode EFF 1 key. To set EFF 2, press the EFF 2 key.  
With the initial settings, the following displays will appear.

When the EFF 1 key is pressed:  
With the initial settings, [Norm HALL] will appear.

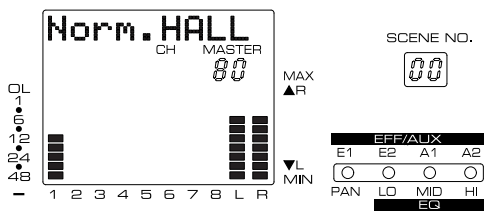

When the EFF 2 key is pressed:  
With the initial settings, [CHORUS] will appear.

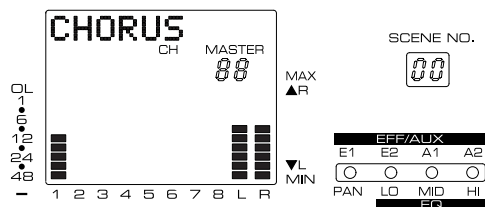

2. Use the DATA encoder to select the effect type.  
The effect types listed in the foregoing tables will appear in succession. When an effect type appears, it will be blinking. The blinking indicates that the effect type has not yet been selected.

- Press the [ENTER] key.  
The effect type will be finalized, and the parameter setting screen will appear.  
The default (initial) parameter values will be displayed.

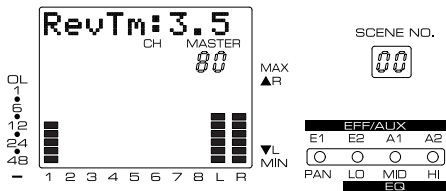

Details on the parameters are given in the following section, "Parameter settings."

- To exit Effect Edit mode, press the EXIT key twice in succession.  
You will return to Normal Mix mode.

< Note >  
When you press the ENTER key to finalize the effect type, the sound will be muted for an instant.

## Effect parameter settings

Here's how to set the effect parameters.

- If the effect parameter that you wish to adjust is not displayed, press the EFF 1 key (or the EFF 2 key) twice.  
One of the parameters of that effect type will appear.
- Press the EFF 1 key (or the EFF 2 key) several times to display the desired parameter.  
The parameters that appear will differ, depending on the effect type that is selected.
- Use the DATA encoder to adjust the value.  
For details on the meaning and range of each parameter, refer to "Effect parameter details" on the next page.
- If you wish to adjust another parameter, repeat from <step 2>.
- When you are finished making settings, press the EXIT key twice to exit Effect Edit mode.

<Useful Information!>  
The parameter display will change as you repeatedly press the EFF 1 (or EFF 2) key. If you hold down the key for a certain length of time, the parameter display will go back to the previous screen.

### <Useful Information!>

When the effect parameter being edited is "Delay Time" or "BPM," you can also use the ENTER key or a foot switch to make the setting by tapping, as an alternative to using the DATA encoder. In order to use the foot switch for tap input, you need to make settings in the Setup mode "Foot switch function setting" menu. For details refer to p.27 "Setup mode."

### < Note for tap input using the ENTER key / foot switch >

When tap input is used, the value will be finalized on the fourth tap. This means that you must tap four times or more.

## Muting an effect

You can mute the effect sound of effect 1 or effect 2.

To mute the effect sound:

Hold down the EXIT key and press the EFF 1 key (or EFF 2 key).  
The effect sound of effect 1 or effect 2 will be muted, and the dry sound will be heard.  
When muting is on, the EFF 1 key (or EFF 2 key) LED will blink.

To cancel muting:

Once again hold down the EXIT key and press the EFF 1 key (or EFF 2 key).  
The dry sound will change back to the effect sound.  
When mute is turned off, the EFF 1 key (or EFF 2 key) LED is off.

### <Useful Information!>

Effect muting can also be switched on/off by a foot switch (separately sold) as an alternative to the above procedure.

The foot switch can be used to switch muting on/off for effect 1 or effect 2, or can simultaneously mute both effect 1 and effect 2. For details refer to p.27 "Setup mode."

## Effect parameter details

The parameters that can be adjusted will depend on the parameter type.

### Reverb effect parameters (parameter type: REVERB)

For effect types 1--24 of the preceding "Effect type" table, the following four parameters can be adjusted.

- |                |  |
|----------------|--|
| 1. REVERB TIME | Adjust the length of reverberation. Range: 0.1--9.9 seconds (99 steps in 0.1 second units)                     |
| 2. PRE DELAY   | Adjust the time from the original sound until reverberation begins. Range: 0--100 ms (101 steps in 1 ms units) |
| 3. HI RATIO    | Adjust the decay ratio of the high frequencies. Range: 0--10 (11 steps in increments of 1)                     |
| 4. E/R BALANCE | Adjust the volume of the early reflections. Range: 0--99 (100 steps in increments of 1)                        |

### Delay+reverb effect parameters (parameter type: DELAY+REVERB)

For effect types 25--28 of the preceding "Effect type" table, the following four parameters can be adjusted.

- |                |   |
|----------------|---|
| 1. DELAY TIME  | Adjust the delay time: Range: 1--230 ms (230 steps in 1 ms units)<br>* The ENTER key / foot switch can be used for tap input (refer to p.21). |
| 2. FEEDBACK    | Adjust the number of delay repeats. Range: 0--99 (100 steps in increments of 1)   |
| 3. DLY BAL     | Adjust the delay balance. Range: 0--99 (100 steps in increments of 1)   |
| 4. REVERB TIME | Adjust the length of reverberation. Range: 0.1--9.9 seconds (99 steps in 0.1 second units)  |

### Delay effect parameters (parameter type: DELAY)

For effect types 29 and 30 of the preceding "Effect type" table, the following four parameters can be adjusted.

- |               |   |
|---------------|---|
| 1. DELAY TIME | Adjust the delay time. Range: 5--680 ms (136 steps in 5 ms units)<br>* The ENTER key / foot switch can be used for tap input (refer to p.21).   |
| 2. FEEDBACK   | Adjust the number of delay repeats. Range: 0--99 (100 steps in increments of 1)   |
| 3. HI RATIO   | Adjust the decay ratio of the high frequencies. Range: 0--10 (11 steps in increments of 1)  |
| 4. FILTER     | Adjust the tone of the delay sound. Range: L9-L1, -, H1-H9<br>* [-] is Filter Off<br>* L1-L9 = LPF (larger numbers will lower the cutoff frequency)<br>* H1-H9 = HPF (larger numbers will raise the cutoff frequency) |

### BPM delay effect parameters (parameter type: BPM DELAY)

For effect types 31 and 32 of the preceding "Effect type" table, the following four parameters can be adjusted.

- |             |   |
|-------------|---|
| 1. BPM      | Adjust the BPM. Range: 30--250 bpm (221 steps in units of 1)<br>* The ENTER key / foot switch can be used for tap input (refer to p.21).  |
| 2. NOTE     | Select the note value for the delay. Range: 24, 16, 8T, 16..8, 4T, 8., 4, 2T, 4., 2, 2., 1<br>* 24 = 16th note sextuplets, 16 = 16th notes, 8T = 8th note triplets, 16. = dotted sixteenth notes, 8 = 8th notes, 4T = quarter note triplets, 8. = dotted eighth notes, 4 = quarter notes, 2T = half-note triplets, 4. = dotted quarter notes, 2 = half notes, 2. = dotted half notes, 1 = whole notes<br>* The "." shown in the ninth character of the LCD indicates a dotted note.<br>* The "T" shown in the ninth character of the LCD indicates a triplet. |
| 3. FEEDBACK | Adjust the number of delay repeats. Range: 0--99 (100 steps in increments of 1)   |
| 4. FILTER   | Adjust the tone of the delay sound. Range: L9-L1, -, H1-H9<br>* [-] is Filter Off<br>* L1-L9 = LPF (larger numbers will lower the cutoff frequency)<br>* H1-H9 = HPF (larger numbers will raise the cutoff frequency)   |

### Short delay effect parameters (parameter type: SHORT DELAY)

For effect type 33 of the preceding "Effect type" table, the following four parameters can be adjusted.

- |               |   |
|---------------|---|
| 1. DELAY TIME | Adjust the delay time. Range: 0.1--9.9 ms (99 steps in 0.1 ms units), 10--99 ms (90 steps in 1 ms units), 100--200 ms (51 steps in 2 ms units)<br>* The ENTER key / foot switch cannot be used for tap input.         |
| 2. FEEDBACK   | Adjust the number of delay repeats. Range: 0--99 (100 steps in increments of 1)   |
| 3. HI RATIO   | Adjust the decay ratio of the high frequencies. Range: 0--10 (11 steps in increments of 1)  |
| 4. FILTER     | Adjust the tone of the delay sound. Range: L9-L1, -, H1-H9<br>* [-] is Filter Off<br>* L1-L9 = LPF (larger numbers will lower the cutoff frequency)<br>* H1-H9 = HPF (larger numbers will raise the cutoff frequency) |

**Doubling effect parameters (parameter type: DOUBLING)**

For effect type 34 of the preceding "Effect type" table, the following three parameters can be adjusted.

- |                   |  |
|-------------------|--|
| 1. Lch DELAY TIME | Adjust the delay time of the L channel. Range: 0.1--9.9 ms (99 steps in 0.1 ms units), 10--99 ms (90 steps in 1 ms units), 100--200 ms (51 steps in 2 ms units)<br>* The ENTER key / foot switch cannot be used for tap input. |
| 2. Rch DELAY TIME | Adjust the delay time of the R channel. Range: 0.1--9.9 ms (99 steps in 0.1 ms units), 10--99ms (90 steps in 1 ms units), 100--200 ms (51 steps in 2 ms units)<br>* The ENTER key / foot switch cannot be used for tap input.  |
| 3. FILTER         | Adjust the tone of the delay sound. Range: L9-L1, -, H1-H9<br>* [-] is Filter Off<br>* L1-L9 = LPF (larger numbers will lower the cutoff frequency)<br>* H1-H9 = HPF (larger numbers will raise the cutoff frequency)          |

**Chorus effect parameters (parameter type: CHORUS)**

For effect type 35 of the preceding "Effect type" table, the following four parameters can be adjusted.

- |                     |   |
|---------------------|---|
| 1. DEPTH            | Adjust the chorus depth. Range: 0--99 (100 steps in increments of 1)  |
| 2. DOUBLING TIME    | Adjust the time difference of the doubling effect. Range: 0--99 (100 steps in increments of 1)  |
| 3. DOUBLING BALANCE | Adjust the volume of the doubling effect. Range: 0--99 (100 steps in increments of 1)   |
| 4. FILTER           | Adjust the tone of the delay sound. Range: L9-L1, -, H1-H9<br>* [-] is Filter Off<br>* L1-L9 = LPF (larger numbers will lower the cutoff frequency)<br>* H1-H9 = HPF (larger numbers will raise the cutoff frequency) |

**Flanger effect parameters (parameter type: FLANGE)**

For effect type 36 of the preceding "Effect type" table, the following four parameters can be adjusted.

- |              |  |
|--------------|--|
| 1. RATE      | Adjust the speed of modulation. Range: 0.1--2.0 Hz (200 steps in 0.01 Hz units)      |
| 2. DEPTH     | Adjust the depth of modulation. Range: 0--99 (100 steps in increments of 1)          |
| 3. MOD DELAY | Adjust the modulation delay. Range: 0--200 (201 steps in increments of 1)            |
| 4. FEEDBACK  | Adjust the number of modulation repeats. Range: 0--99 (100 steps in increments of 1) |

**Delay pitch effect parameters (parameter type: DELAY PITCH)**

For effect type 38 of the preceding "Effect type" table, the following four parameters can be adjusted.

- |             |  |
|-------------|--|
| 1. PITCH    | Adjust the amount of pitch shift. Range: -24--0--24 (49 steps in semitone units)<br>* +/-12 is one octave, +/-24 is two octaves.   |
| 2. ADJUST   | Make fine adjustments to the amount of pitch shift. Range: -50--0--50 (101 steps in increments of 1)<br>* +50 is a semitone sharp, -50 is a semitone flat.                             |
| 3. DLY TIME | Adjust the delay time until the pitch-shifted sound is heard. Range: 0--500 (251 steps in increments of 2)<br>* The ENTER key / foot switch can be used for tap input (refer to p.21). |
| 4. FEEDBACK | Adjust the number of delay repeats. Range: 0--99 (100 steps in increments of 1)  |

**Mono pitch effect parameters (parameter type: MONO PITCH)**

For effect type 37 of the preceding "Effect type" table, the following three parameters can be adjusted.

- |           |  |
|-----------|--|
| 1. PITCH  | Adjust the amount of pitch shift. Range: -24--0--24 (49 steps in semitone units)<br>* +/-12 is one octave, +/-24 is two octaves.                           |
| 2. ADJUST | Make fine adjustments to the amount of pitch shift. Range: -50--0--50 (101 steps in increments of 1)<br>* +50 is a semitone sharp, -50 is a semitone flat. |
| 3. MODE   | Select the processing method. Range: 1--3 (3 steps)  |

## Scene Memory Mode

The VM08 provides 21 scene memories (scene numbers 00--20). Of these, scene number [00] is a preset scene named "Initial Mix," and cannot be modified by the user. Your own settings can be stored in scene numbers [01]--[20]. Each scene stores the contents of Normal Mix mode, Channel Parameter Edit mode, and Effect Edit mode as a set. An eight-character alphanumeric name can be assigned to each scene memory you store.

### Storing a scene memory

Here's how to store the current mix data as a scene memory.

1. Press the SCENE STORE key.

The number and name of the currently selected scene will blink.

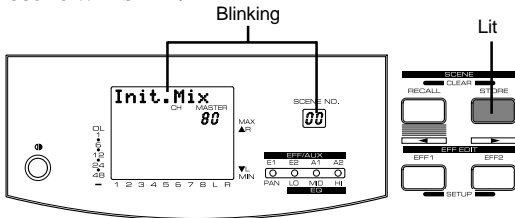

2. Rotate the DATA encoder to select the scene number [01]--[20] into which you wish to store the settings.

3. Press the ENTER key.

The store destination scene number will be finalized, and you will now be able to input the scene name. The current scene name will be displayed.

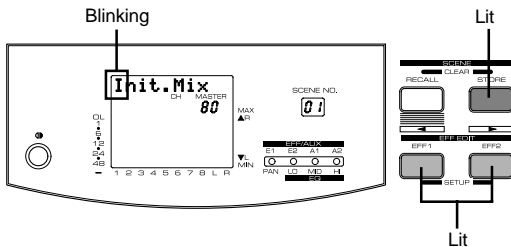

#### < Note >

If you select scene number [00] and attempt to store, the display will indicate [Read Only], and the operation will be ignored.

4. Use the DATA encoder and cursor keys (EFF 1 key / EFF 2 key) to input the scene name. A scene name of up to eight characters can be assigned, using the following characters and symbols.

A ~ Z a ~ z 0 ~ 9 + - \* / # & ! ? ( ) [ ]  
< > : . , <- -> \_

5. When you have finished entering the scene name, press the ENTER key.

#### <Useful Information!>

The scene memories you store are preserved even when the power is turned off. However if you reset the VM08 (by pressing the RESET key), all scene memories other than scene number [00] will return to the initial state.

If you decide to halt the process during the scene memory store procedure, press the EXIT key. From any point in the procedure, this will return you to Normal Mix mode.

### Recalling a scene memory

Here's how to recall a previously-stored scene memory.

1. Press the SCENE RECALL key.

The scene number and scene name will blink.

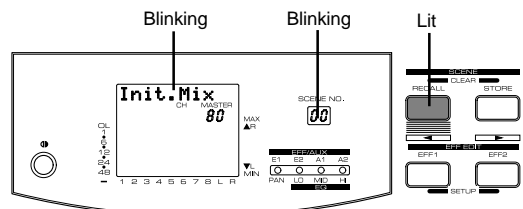



2. Rotate the DATA encoder to select the scene number [00]--[20] that you wish to recall.  
As the scene number changes, the corresponding scene name will be displayed.

3. Press the ENTER key.  
The scene will be recalled.

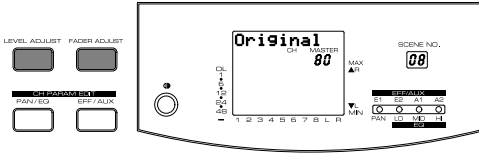

< Note >

- \* The contents that are recalled will depend on the Setup mode settings "Channel fader recall" and "Master fader recall" described later in this manual. For details refer to "Setup mode" later in this manual.
- \* Regardless of the position of the faders when a scene is recalled, the sound will be output at the stored volumes from the instant of the recall. If you are monitoring through headphones, be careful of the sudden loud sounds that may occur when a scene is recalled.

## Level adjust

When the physical fader locations and the actual volumes do not match (for example, after a scene memory has been recalled), you can use this function to force the volume levels to the current fader locations.

1. Press the LEVEL ADJUST key.  
The display will ask [Level Adj?].

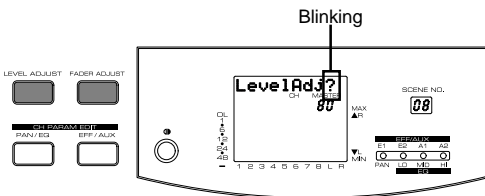

2. Press the ENTER key.  
The Level Adjust operation will be executed.  
This will cause the volumes to change to the current fader locations.

## Fader adjust

When the physical fader locations and the actual volumes do not match (for example, after a scene memory has been recalled), you can use this function to manually adjust the fader locations.

< Note >

Fader Adjust will function in Normal Mix mode as well as after a scene is recalled. In Normal Mix mode, the FADER ADJUST key / LEVEL ADJUST key will blink to indicate that the fader locations before the VM08's power is turned off are different than the fader locations when the power was turned on.

1. Press the FADER ADJUST key.  
The display will indicate [Fader Adj]. The level section of the display will show dots to indicate the current locations of the faders, and blinking dots to indicate the current actual volume levels.

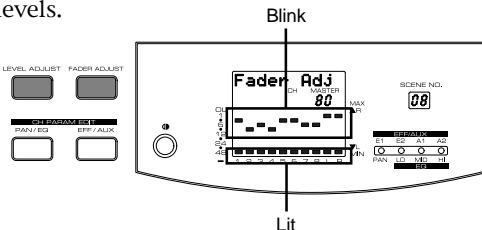

Raising or lowering the faders will not affect the actual volume that you are hearing.

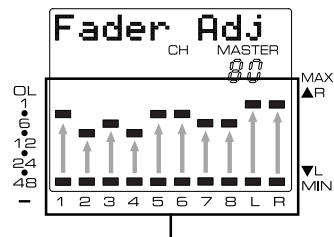

Move each fader so that the lit dots coincide with the blinking dots.

2. Move each fader so that the lit dots move to the locations of the blinking dots.

3. Press the EXIT button to exit the Fader Adjust function.

## Directly recalling a scene memory

In addition to the method described earlier in "Scene recall," a scene memory can also be recalled directly using the following method of stepping consecutively through the stored scenes.

**< Note >**

Only user scene memories (scene numbers [01]--[20]) can be selected using this method of direct recall. Preset scene number [00] cannot be recalled.

1. Hold down the EXIT key and press the SCENE RECALL key.

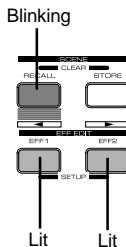
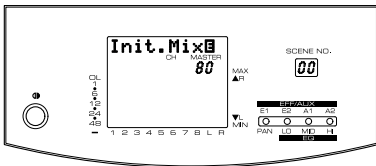

2. Press the EFF 1 key or EFF 2 key. Pressing the EFF 2 key will make the scene number change in the forward direction. Pressing the EFF 1 key will make the scene number change in the backward direction.
3. To exit this mode, press the EXIT key. You will exit scene direct recall mode and return to normal mix mode.

**<Useful Information!>**

Scene direct recall can also be performed using a separately sold foot switch. If you connect an unlatch type foot switch (e.g., model 8051) to the FOOT SW jack, you can use the foot switch to perform the procedure described above. When you press the foot switch, you will enter scene direct recall mode, and pressing the foot switch again will step through the scene numbers. If you hold down the foot switch, you will return to the previous scene number. Here too, you can press the EXIT key to exit scene direct recall mode. In order to use a foot switch to recall scenes, you must make the appropriate setting in "Setup mode" described later in this manual. For details refer to "Setup mode" on the following page.

## Clearing a scene memory

Here's how to clear a specific scene memory.

1. Simultaneously hold down the SCENE RECALL key and SCENE STORE key. The number and name of the currently selected scene will be displayed.
2. Rotate the DATA encoder to select the scene number that you wish to clear, and press the ENTER key. The display will ask whether you wish to clear the selected scene number. (The example screen shown here is when you have selected scene number [02].)

3. Press the ENTER key. The scene memory will be cleared.

**< Note >**

If you select scene number [00] and attempt to clear it, the display will indicate [Read Only], and the operation will be ignored. Only scene numbers [01]--[20] can be cleared.

The display will indicate [Clear 02 ?], and [?] will blink.

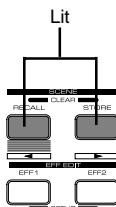
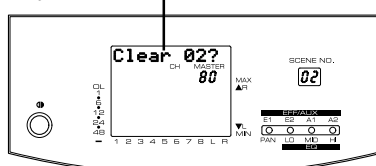

## Setup Mode

In Setup mode you can make the following settings to specify how the VM08 will operate.

1. INPUT 5/6 setting (specify INPUT 5/6 as stereo or mono input)
2. INPUT 7/8 setting (specify INPUT 7/8 as stereo or mono input)
3. Fader Fix setting (turn Fader Fix mode on/off)
4. ChFdrRcl setting (turn Recall mode on/off for the channel faders)
5. MsFdrRcl setting (turn Recall mode on/off for the master fader)
6. Foot Sw setting (specify the function of the foot switch)
7. BattVolt check (check the voltage of the internal battery)

### Making settings in setup mode

To make settings in Setup mode, use the following procedure to select the menu item that contains the setting you wish to change. (However, the internal battery check is for display only, and cannot be modified.)

1. Simultaneously press the EFFECT EDIT keys EFF 1 and EFF 2.  
You will enter Setup mode.

The previously-selected setup menu item will appear.

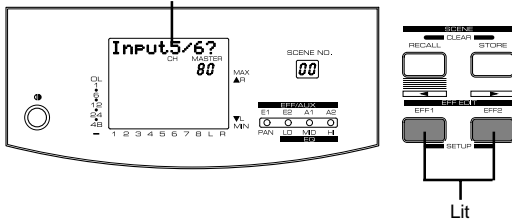

2. Use the DATA encoder to select the desired setup menu item.
3. Press the ENTER key.  
The currently selected item will blink in the display.

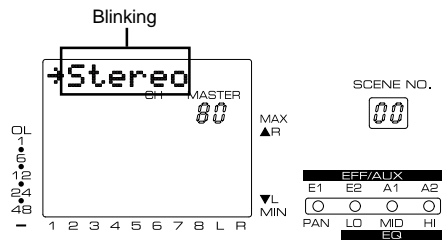

4. Use the DATA encoder to select the desired setting.  
For details on the available settings, refer to the following page.
5. Press the ENTER key.  
The selection will be finalized, and you will return to the display of <step 1>.
6. Press the EXIT key.  
You will return to Normal Mix mode.

### Details of the setup menu

**INPUT 5/6 input setting (Display: [Input5/6?])**  
Here you can specify the input mode for INPUT 5/6.

<Settings>  
Stereo (default)  
In 5>Mono

If Stereo is selected, the INPUT 5/6 jack will be used in stereo input mode, and separate signals will be sent to channels 5 and 6. Use this setting when inputting a stereo signal. If In 5>Mono is selected, mono input mode will be used, and the same signal will be input to channels 5 and 6. Use this setting when inputting a mono signal. For more about the INPUT 5/6 jack, refer to p.8 "Connecting other equipment."

**INPUT 7/8 input setting (Display: [Input7/8?])**  
Here you can specify the input mode for INPUT 7/8.

<Settings>  
Stereo (default)  
In 7>Mono

If Stereo is selected, the INPUT 7/8 jack will be used in stereo input mode, and separate signals will be sent to channels 7 and 8. Use this setting when inputting a stereo signal. If In 7>Mono is selected, mono input mode will be used, and the same signal will be input to channels 7 and 8. Use this setting when inputting a mono signal. For more about the INPUT 7/8 jack, refer to p.8 "Connecting other equipment."

**Fader Fix setting (Display: [FaderFix ?])**

<Settings>  
ON  
OFF (default)

If this setting is turned on, the faders will no longer function in any mode. This allows you to prevent the fader positions from being changed by accident or by vibration.

**Channel fader recall setting (Display: [ChFdrRcl ?])**

<Settings>  
ON (default)  
OFF

If this setting is turned off, only the input fader settings of each channel will be unaffected when you recall a scene. In other words, the six input faders will maintain the settings that they had immediately before the scene was recalled. Regardless of this on/off setting, the input faders will continue to function normally in all modes, as well as when you store a scene.

**Master fader recall setting (Display: [MsFdrRcl ?])**

<Settings>  
ON (default)  
OFF

If this setting is turned off, the setting of the master fader will be unaffected when you recall a scene. In other words, the master fader will maintain the setting that it had immediately before the scene was recalled. This is convenient when you wish to set just the output level yourself, for example during a live performance. Regardless of this on/off setting, the master fader will continue to function normally in all modes, as well as when you store a scene.

**Foot Switch setting (Display: [Foot Sw ?])**

Here you can specify the function of the foot switch.

<Settings>  
-> SceneU/D (default)  
-> ST Mute  
-> EFF1 Mute  
-> EFF2 Mute  
-> E1&E2 Mute  
-> Delay Tap

**SceneU/D:** Access the Scene Direct Recall function. Pressing the foot switch once will enter Scene Direct Recall mode; subsequent presses of the foot switch will advance the scene number forward, and holding down the foot switch will return to the previous scene number. To exit Direct Recall mode, press the EXIT key.

**ST Mute:** Switch muting on/off for the ST master signal

**EFF1 Mute:** Switch muting on/off for EFF 1

**EFF2 Mute:** Switch muting on/off for EFF 2

**E1&E2 Mute:** Switch muting on/off for EFF 1 / EFF 2.

**Delay Tap:** When editing effect parameters, use the foot switch for tap in put of Delay Time or BPM.

**Battery check (Display: [BattVolt ?])**

This lets you check the voltage of the internal battery. After selecting this menu item, press the ENTER key. The voltage of the internal battery will be displayed, allowing you to check it. When you have checked the voltage, press the EXIT key to exit Setup mode.

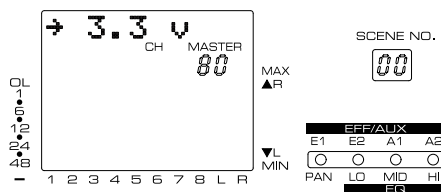

The life of the internal battery is approximately two years. When the battery runs down and the voltage decreases to a certain level, a warning message of [Batt Empty] will appear in the display when the VM08 is powered-on. It is not possible for the user to replace the internal battery. Please contact a nearby Fostex office or service station. For details on the [Batt Empty] message, refer to page 6 "Before Operation."

# Specifications

## <INPUT 1 ~ 4>

Connector :  $\phi$ 6mm phone jack/Un-balanced (x 4)  
 Input impedance : 20k $\Omega$  ore more  
 Input level : -50dBV ~ -6dBV

## <INPUT 5/6 ~ 7/8>

Connector :  $\phi$ 6mm TRS phone jack Un-balanced (x 2)  
 Input impedance : 20k $\Omega$  ore more  
 Input level : -6dBV

## <STEREO OUT L, R>

Connector :  $\phi$ 6mm phone jack/Un-balanced (x 2)  
 Load impedance : 10k $\Omega$  ore more  
 Output level : -10dBV

## <AUX SEND 1/2>

Connector :  $\phi$ 6mm TRS phone jack Un-balanced (x 1)  
 Load impedance : 10k $\Omega$  ore more  
 Output level : -10dBV

## <PHONES OUT>

Connector :  $\phi$ 6mm stereo phone jack (x 1)  
 Load impedance : 16 $\Omega$  ore more  
 Output Level : 20mW (at 16 $\Omega$  load)

## <S/P DIF OUT>

Connector : Optical (x 1)  
 Format : IEC 60958 (S/P DIF)

## <FOOT SWITCH>

Connector :  $\phi$ 6mm phone jack (x 1)  
 Model 8051 foot switch

## <OTHERS>

Equalizer  
 HI : 10kHz +/-18dB (shelving type)  
 MID : 1kHz +/- 18dB (peaking type)  
 LO : 100Hz +/- 18dB (shelving type)  
 Frequency response : 20Hz ~ 20kHz (TYPICAL)  
 Dynamic range : 90dB (TYPICAL)  
 A/D : 20bit 64 times over sampling  $\Delta\Sigma$   
 D/A : 24bit 128 times over sampling  $\Delta\Sigma$   
 Sampling frequency : 44.1kHz  
 Total harmonic distortion : 0.01% (TYPICAL)  
 Crosstalk : 70dB or more @1kHz

## <GENERAL:>

Dimensions : 300 (W)x70 (H)x212 (D) mm  
 Weight : Approx. 1.2kg  
 DC IN : DC9V, 650mA, AC adaptor (AD-9B)

\* Specifications and appearance are subject to change without notice for product improvement.

## Block Diagram

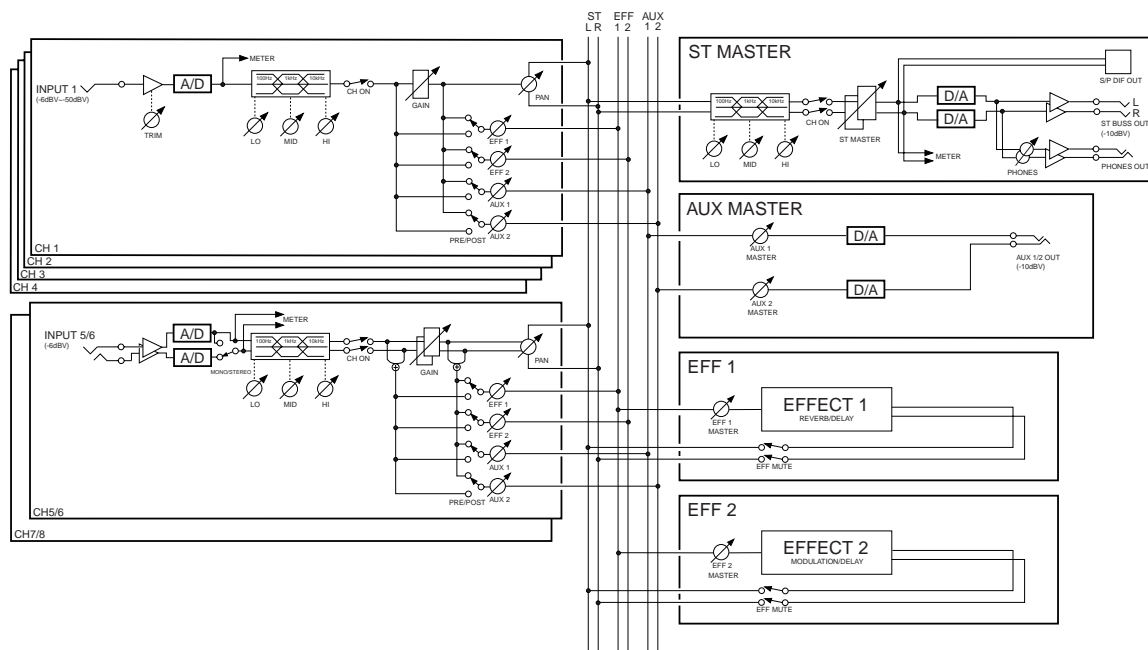

## Declaration of EC Directive

This equipment is compatible with the EMC Directive (89/336/EEC) - Directive on approximation of member nation's ordinance concerning the electromagnetic compatibility and with the Low Voltage Directive (73/23/EEC) - Directive on approximation of member nation's ordinance concerning electric equipment designed to be used within the specified voltage range.

### The Affect of Immunity on This Equipment

The affect of the European specification EN50082-1 (coexistence of electromagnetic waves - common immunity specification) on this equipment are as shown below.

In the electrical fast transient / burst requirements, radiated electromagnetic field requirements and static electricity discharging environment, this could be affected by generation of noise in some cases.

## Fostex Distributors List In Europe

\* Including non - EU countries. \* underlined: contracted distributors (as of April, 1999)

### <AUSTRIA>

NAME: ATEC Audio-u. Videogeraete VertriebsgesmbH.  
ADD: Im Winkel 5, A-2325 Velm, Austria  
TEL: (+43) 2234-74004, FAX: (+43) 2234-74074

### <BELGIUM>

NAME: EML Sound Industries NV  
ADD: Bijvenestraat 1A, B3500 Hasselt, Belgium  
TEL: (+32) 11-232355, FAX: (+32) 11-232172

### <DENMARK>

NAME: SC Sound ApS  
ADD: Malervej 2, DK-2630 Taastrup, Denmark  
TEL: (+45) 4399-8877, FAX: (+45) 4399-8077

### <FINLAND>

NAME: Noretron Oy Audio  
ADD: P. O. Box 22, FIN-02631 Espoo, Finland  
TEL: (+358) 9-5259330, FAX: (+358) 9-52593352

### <FRANCE>

NAME: Musikengro  
ADD: ZAC de Folliouses, B. P. 609, 01706 Les Echets, France  
TEL: (+33) 472 26 27 00, FAX: (+33) 472 26 27 01

### <GERMANY>

NAME: Studiosound & Music GmbH  
ADD: Industriestrasse 20, D-35041 Marburg, F. R. Germany  
TEL: (+49) 6421-92510, FAX: (+49) 6421-925119

### <GREECE>

NAME: Bon Studio S. A.  
ADD: 6 Zaimi Street, Exarchia, 106.83 Athens, Greece  
TEL: (+30) 1-3809605-8, 3302059, FAX: (+30) 1-3845755

### <ICELAND>

NAME: I. D. elrf. electronic Ltd.  
ADD: Armula 38 108 Reykjavik, Iceland  
TEL: (+354) 588 5010, FAX: (+354) 588 5011

### <ITALY>

NAME: Recoton Italia Srl.  
ADD: V. 1 Maggio, N 18, 40050 Quarto Inferiore, (BO) Italy  
TEL: (+39) 051-768576, FAX: (+39) 051-768336

### <THE NETHERLANDS>

NAME: IEMKE ROOS AUDIO B. V.  
ADD: Kuiperbergweg 20, 1101 AG Amsterdam, The Netherlands  
TEL: (+31) 20-697-2121, FAX: (+31) 20-697-4201

### <NORWAY>

NAME: Siv. Ing. Benum A/S  
ADD: P. O. Box 145 Vinderen, 0319 Oslo 3, Norway  
TEL: (+47) 22-139900, FAX: (+47) 22-148259

### <PORTUGAL>

NAME: Caius - Tecnologias Audio e Musica, Lda.  
ADD: Rua de Santa Catarina, 131 4000 Porto, Portugal  
TEL: (+351) 2-2086009/2001394, FAX: (+351) 2-2054760/2087488

### <SPAIN>

NAME: Multitracker. S. A.  
ADD: C/Garcilaso No. 9, Madrid 28010, Spain  
TEL: (+34) 91-4470700, 91-4470898, FAX: (+34) 91-5930716

### <SWEDEN>

NAME: TTS Professional Television AB  
ADD: Kavallerivagen 24, 172 48 Sundbyberg, Sweden  
TEL: (+46) 8-59798000, FAX: (+46) 8-59798001

### <SWITZERLAND>

NAME: Audio Bauer Pro AG  
ADD: Bernerstrasse-Nord 182, CH-8064 Zurich, Switzerland  
TEL: (+41) 1-4323230, FAX: (+41) 1-4326558

### <UK>

NAME: SCV London  
ADD: 3A 6-24 Southgate Road, London N1 3JJ, England, UK  
TEL: (+44) 171-923-1892, FAX: (+44) 171-241-3644