



SIP1

USERGUIDE



Stages Indoor Cycling® LLC
www.stagesindoorcycling.com
support@stagesindoorcycling.com
1-800-717-8076

Offices:

Sales, Accounting and Administrative ,Tech. Support: 1732 NW Quimby,
Ste 250, Portland, OR 97209 USA

Design, Manufacturing, and Warehouse: 3090 Sterling Cir, Ste 102,
Boulder, CO 80301 USA

Specifications

- Batteries AA x 2 – service life, approximately 2000 hours of riding time
- Wireless transmission: 2.4GHz, ANT+™ and Bluetooth® Smart (BTLE 4.0)
- Accuracy: +/-2.5% of measured power
- Power measurement range: (watts): 0 – 2500
- Cadence range (RPM): 20-220
- Water resistance rating: IPX7



This product is ANT+ certified and complies with the following specified
ANT+ Device Profiles:



www.thisisant.com/directory

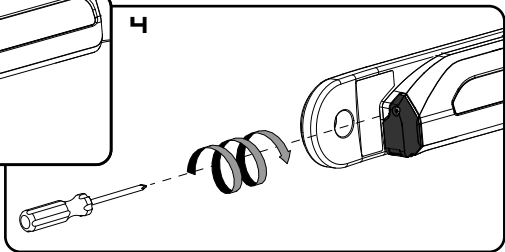
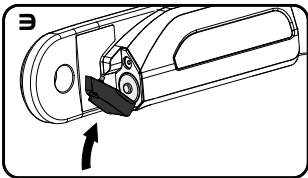
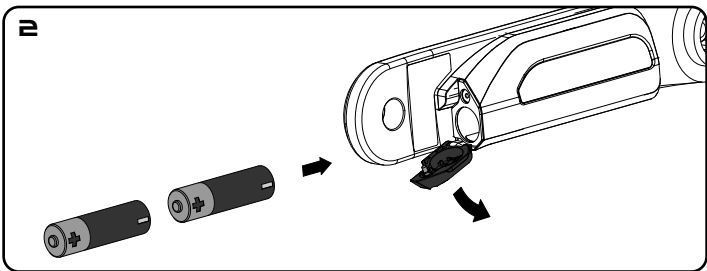
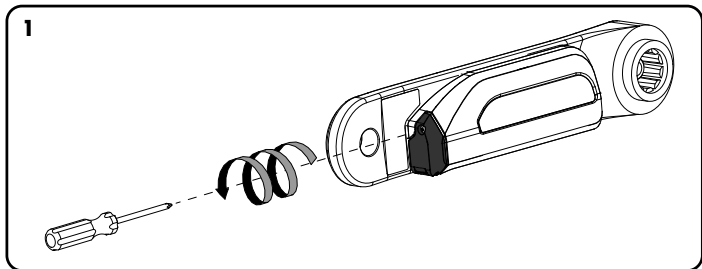

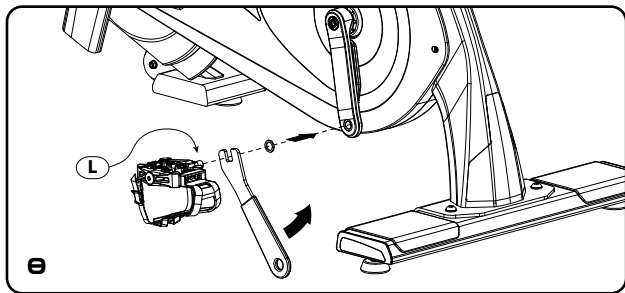
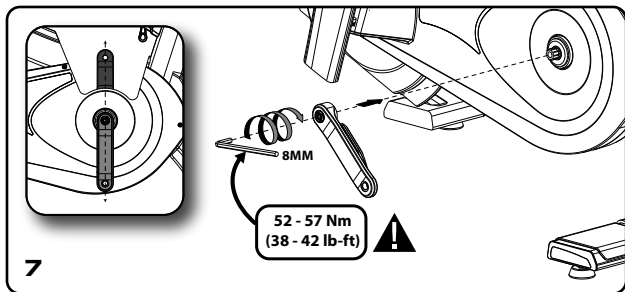
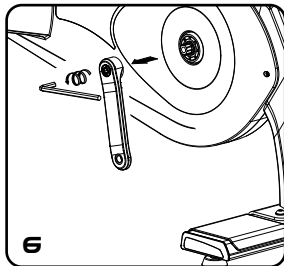
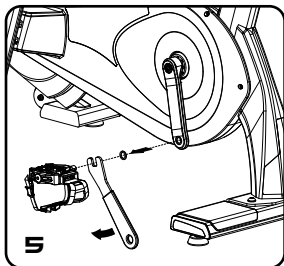

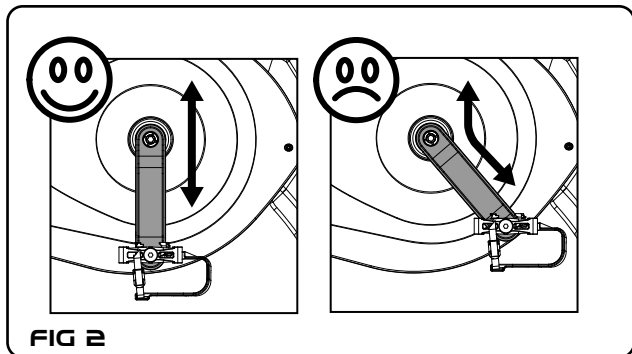
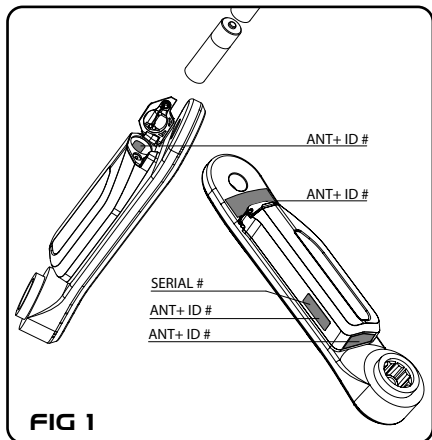

Pairing the power meter

The power meter must be connected or “paired” to the Stages SIC1 display console or cycle computer (collectively referred to as display units) according to the manufacturer’s instructions. Each power meter has a unique ANT+ device ID. During the pairing process the applicable device ID is recorded by the display and will be used to communicate with the corresponding power meter. The ANT+ ID number is printed in the locations shown in FIG 1 and also supplied with the documentation. Once paired to the power meter, ride data (Watts and RPM) will be transmitted from the power meter to the display unit. Other important functions such as resetting the power meter’s zero offset will also be enabled through the display unit. **The ANT+ is permanently assigned to the power meter and is not affected by changing the power meter battery.**

When Pairing to a Stages SIC1 Console: Ensure the power meter has fully charged AA batteries properly installed. Rotate the crank arm one time to ensure the power meter is awake. Follow the instructions in the Stages console user guide for pairing the power meter to the console.

When Pairing to Another Type of Compatible ANT+ Display: Ensure the power meter has fully charged AA batteries properly installed. Rotate the crank arm one time to ensure the power meter is awake and ready to communicate. Follow the ANT+ device manufacturer’s instructions for pairing a power meter to the display unit. The procedures may vary between manufacturers.

Zero Offset Calibration

The zero offset calibration is an important feature of the power meter that resets the zero offset value for the power meter sensors. There are physical and environmental conditions that may affect the zero offset value and there are methods both manual and automatic that will adjust this value to accommodate for the changing physical and environmental condition. The zero offset of the power meter is essentially the sensor reading or values measured when the power meter has no pedaling load (torque) applied. The act of calibrating the zero offset causes the power meter to measure the value at zero load and then records this value as the baseline for power measurement.

Loads applied while pedaling will then be measured as torque and used by the sensor to determine power in Watts. The zero offset value can be affected by the installation of the crank arm and the tightening of the securing hardware. The torque applied to the securing hardware can impart some strain into the crank material that is easily accounted for by manually calibrating the zero offset. Any time the power meter is removed from the bike and reinstalled, the zero offset should be calibrated.

How to calibrate the zero offset

Calibrating the zero offset is a function controlled by the Stages SIC1 display console, or cycle computer (display units) paired to the power meter. Please note that some device manufacturers refer to the step of resetting the zero offset as “calibration”. When paired to a Stages SIC1 display console or other compatible ANT+ cycle computer, the power meter and display units are in two-way communication. The display unit will send a command to the power meter to calibrate the zero offset value and in some cases the resulting zero offset value will be sent back from the power meter to the display unit and be shown on the screen. Please note the displayed zero offset value will NOT be zero but rather a number that corresponds to the measurement taken by the sensor. The display units will also indicate if the procedure was successful or failed.

Before attempting to calibrate the zero offset value of the power meter, ensure that a working battery is in use and the pedal is attached. Rotate the power meter one revolution to ensure the power meter is awake and ready to communicate.

The left crank arm with power meter **MUST** be positioned straight down (6 o'clock position) and ensure there is no load on the pedals and the bike is stable. See FIG 2 for a visual reference. If the left crank arm is not straight down the reset procedure for zero offset will fail.

To calibrate the zero offset of the power meter, follow the instructions supplied with Stages SIC1 display console or ANT+ display console being used with the power meter.

Troubleshooting

If no power (watts) or cadence (RPM) signal is being received by your compatible display unit when riding the bike, please confirm the following items:

1. Confirm that working AA batteries are properly installed in the power meter according to assembly steps 1-4 on page 3.
2. Ride the bike with a pedaling cadence of greater than 20 RPM. Your power meter will not send cadence or wattage to the display unless a true pedaling force is applied. If you pedal the bike by hand the display will not show cadence or watts — this is not a problem — as soon as you ride the bike you will see your cadence and power values displayed.
3. Ensure that the power meter has been successfully paired to the display unit being used according the manufacturer's specific instructions.
4. For further assistance with Troubleshooting, FAQs, videos and useful tips, please visit our website.

Maintenance and cleaning

The only items of the power meter that can be serviced by the owner are the batteries, battery door, and battery door gasket. No other items are serviceable and no attempt should be made to adjust or alter any other items.

When cleaning the power meter use only water dampened cloth to wipe off dirt and debris. Never use any harsh cleaning chemicals that may damage the plastic housing. Inspect the battery compartment to ensure the batter contact is clean of any corrosion.

Firmware

Firmware is the programming that operates the power meter's computer. The power meter has been designed to allow over-the-air (OTA) firmware updates. Updated firmware may be developed and released by Stages Cycling to provide added or improved functionality. Firmware updates may be sent to the power meter by way of the Stages Cycling Utility Apps for Apple® iOS devices such as iPhone and iPads, as well as Android devices (running Android software 4.4 or newer). Compatible mobile devices must support Bluetooth Smart (BTLE 4.0). Please visit

www.stagesindoorcycling.com/support

for links to the available utility Apps hosted in the App stores as well as instructions on how to utilize the App for firmware update and other procedures.

Warranty procedures

Complete warranty details are available in our Important Product Information document and at our website FAQ page:

<http://www.stagesindoorcycling.com/support>

To pursue a warranty claim please contact the dealer that sold the power meter. If the power meter was purchased directly contact Stages Indoor Cycling:

In all cases a Return Authorization Number (RA#) must be issued by Stages Indoor Cycling before any product is returned for warranty inspections and service.

The Stages power meter device may be protected by USA or foreign patents or patents pending.

This document may contain trademarks or registered trademarks of Stages Cycling LLC as represented by the use of ™ and ® respectively.

ANT+™ is a trademark of Dynastream Innovations Inc.

Bluetooth® is a registered trademark of Bluetooth SIG, Inc.

Apple®, iPhone®, iPad® are registered trademarks of Apple Inc.

Android™ is a trademark of Google Inc.

Copyright ©Stages Indoor Cycling LLC, 2015

Stages Indoor Cycling™

Important Product Information

Contact Information:
Stages Indoor Cycling LLC
1732 NW Quimby
Suite 250
Portland, OR 97209
www.stagesindoorcycling.com
Support@stagesindoorcycling.com

Product Name: Stages Indoor Power Meter
Model Name: SIP1
FCC ID: ZBM-SIP1
IC ID: 9327A-SIP1

California Proposition 65

The enclosed hardware and its packaging contain chemicals the State of California has found to cause cancer, birth defects or reproductive harm.

RoHS

Stages Cycling certifies that this product and its packaging are in compliance with European Union Directive 2011/65/EU on the Restriction of the Use of Certain Hazardous Substances in Electrical and Electronics Equipment, commonly known as RoHS.

FCC Rules Part 15

The enclosed hardware device complies with part 15 of the FCC Rules. Operation is subject to the following two conditions: (1) This device may not cause harmful interference and (2) it must accept any interference received, including interference that may cause undesired operation.

FCC Compliance Statement:

This equipment has been tested and found to comply with limits for a Class B digital device, pursuant to Part 15 of the FCC rules. These limits are designed to provide reasonable protection against harmful interference in residential installations. This equipment generates, uses, and can radiate radio frequency energy, and if not installed and used in accordance with the instructions, may cause harmful interference to radio communications. However, there is no guarantee that interference will not occur in a particular installation. If this equipment does cause interference to radio or television equipment reception, which can be determined by turning the equipment off and on, the user is encouraged to try to correct the interference by one or more of the following measures:

- Reorient or relocate the receiving antenna
- Increase the separation between the equipment and receiver
- Connect the equipment into an outlet on a circuit different from that to which the receiver is connected.
- Consult the dealer or an experienced radio/TV technician for help

To assure continued compliance, any changes or modifications not expressly approved by the party responsible for compliance could void the user's authority to operate this equipment. (Example- use only shielded interface cables when connecting to a computer or peripheral devices).

⚠ Caution! The manufacturer is not responsible for any radio or TV interference caused by unauthorized modifications to this equipment. Such modifications could void the users authority to operate the equipment.

FCC Radiation Exposure Statement

This equipment complies with FCC RF radiation exposure limits set forth for an uncontrolled environment. This equipment should be installed and operated with a minimum distance of 0.5 centimeters between the radiator and your body. This transmitter must not be co-located or operating in conjunction with any other antenna or transmitter.

The antennas used for this transmitter must be installed to provide a separation distance of at least 0.5 cm from all persons and must not be co-located or operating in conjunction with any other antenna or transmitter.

IC Statement

This device complies with Industry Canada license-exempt RSS standard(s). Operation is subject to the following two conditions: (1) this device may not cause interference, and (2) this device must accept any interference, including interference that may cause undesired operation of the device. The device meets the exemption from the routine evaluation limits in section 2.5 of RSS 210 and users can obtain Canadian information on RF exposure and compliance.

Le présent appareil est conforme aux CNR d'Industrie Canada applicables aux appareils radio exempts de licence. L'exploitation est autorisée aux deux conditions suivantes: (1) l'appareil ne doit pas produire de brouillage, et (2) l'utilisateur de l'appareil doit accepter tout brouillage radioélectrique subi, même si le brouillage est susceptible d'en compromettre le fonctionnement. Le dispositif rencontre l'exemption des limites courantes d'évaluation dans la section 2.5 de RSS102 et les utilisateurs peuvent obtenir l'information canadienne sur l'exposition et la conformité de rf.

CE statement :

Europe – EU Declaration of Conformity This device complies with the essential requirements of the R&TTE Directive 1999/5/EC. The following test methods have been applied in order to prove presumption of conformity with the essential requirements of the R&TTE Directive 1999/5/EC:

EN 60950-1:2006+A11:2009+A1:2010+A12:2011+A2:2013

EN 301 489-1 : V1.9.2 (2011)

EN 301 489-17: V2.2.1 (2012)

EN 300 328 (v1.8.1, 2012-6)

EN62479 (2010)

This device is a 2.4 GHz wideband transmission system (transceiver), intended for use in all EU member states and EFTA countries, except in France and Italy where restrictive use applies. In Italy the end-user should apply for a license at the national spectrum authorities in order to obtain authorization to use the device for setting up outdoor radio links and/or for supplying public access to telecommunication-tions and/or network services. This device may not be used for setting up outdoor radio links in France and in some areas the RF output power may be limited to 10 mW EIRP in the frequency range of 2454 – 2483.5 MHz. For detailed information the end-user should contact the national spectrum authority in France. Hereby, Stages Indoor Cycling declares that these products are in compliance with the essential requirements and other relevant provisions of Directive 1999/5/EC.

STAGES INDOOR CYCLING LLC (1) One Year Limited Warranty

HOW CONSUMER LAW RELATES TO THIS WARRANTY

THIS WARRANTY GIVES YOU SPECIFIC LEGAL RIGHTS, AND YOU MAY HAVE OTHER RIGHTS THAT VARY FROM STATE TO STATE (OR BY COUNTRY OR PROVINCE). OTHER THAN AS PERMITTED BY LAW, STAGES INDOOR CYCLING DOES NOT EXCLUDE, LIMIT OR SUSPEND OTHER RIGHTS YOU MAY HAVE. FOR A FULL UNDERSTANDING OF YOUR RIGHTS YOU SHOULD CONSULT THE LAWS OF YOUR COUNTRY, PROVINCE OR STATE.

WARRANTY LIMITATIONS THAT MAY AFFECT CONSUMER LAW

TO THE EXTENT PERMITTED BY LAW, THIS WARRANTY AND THE REMEDIES SET FORTH ARE EXCLUSIVE AND IN LIEU OF ALL OTHER WARRANTIES, REMEDIES AND CONDITIONS, WHETHER ORAL, WRITTEN, STATUTORY, EXPRESS OR IMPLIED. STAGES INDOOR CYCLING DISCLAIMS ALL STATUTORY AND IMPLIED WARRANTIES, INCLUDING WITHOUT LIMITATION, WARRANTIES OF MERCHANTABILITY AND FITNESS FOR A PARTICULAR PURPOSE AND WARRANTIES AGAINST HIDDEN OR LATENT DEFECTS, TO THE EXTENT PERMITTED BY LAW. IN SO FAR AS SUCH WARRANTIES CANNOT BE DISCLAIMED, STAGES INDOOR CYCLING LIMITS THE DURATION AND REMEDIES OF SUCH WARRANTIES TO THE DURATION OF THIS EXPRESS WARRANTY AND, AT STAGES INDOOR CYCLING'S OPTION, THE REPAIR OR REPLACEMENT SERVICES DESCRIBED BELOW. IN NO EVENT WILL THE VALUE OF THE WARRANTY PROVIDED EXCEED THE ORIGINAL PURCHASE PRICE. SOME STATES (COUNTRIES AND PROVINCES) DO NOT ALLOW LIMITATIONS ON HOW LONG AN IMPLIED WARRANTY (OR CONDITION) MAY LAST, SO THE LIMITATION DESCRIBED ABOVE MAY NOT APPLY TO YOU.

WHAT IS COVERED BY THIS WARRANTY?

Stages Indoor Cycling warrants the Stages Cycling-branded hardware product and accessories contained in the original packaging ("Stages Cycling Product") against defects in materials and workmanship when used normally in accordance with Stages Indoor Cycling's published guidelines for a period of ONE (1) YEAR from the date of original retail purchase by the end-user purchaser ("Warranty Period"). This warranty only applies to the original owner and is not transferable.

WHAT IS NOT COVERED BY THIS WARRANTY?

This warranty applies to Stages Cycling branded products including but not limited to crank arms when packaged or sold with Stages Cycling hardware. Manufacturers, suppliers, or publishers, other than Stages Indoor Cycling, may provide their own warranties to you but Stages Indoor Cycling, in so far as permitted by law, provides their products "AS IS". Stages Indoor Cycling does not warrant that the operation of the Stages Cycling Product will be uninterrupted or error-free. Stages Indoor Cycling is not responsible for damage arising from failure to follow instructions relating to the Stages Cycling Product's use. Stages Indoor Cycling's published guidelines include but are not limited to information contained in technical specifications, user manuals and service communications.

This warranty does not apply: (a) to consumable parts, such as batteries or protective coatings that are designed to diminish over time, unless failure has occurred due to a defect in materials or workmanship; (b) to cosmetic damage, including but not limited to scratches and dents; (c) to damage caused by use with another product; (d) to damage caused by accident, impact, abuse, misuse, fire, earthquake or other external cause; (e) to damage caused by operating the Stages Cycling Product outside Stages Indoor Cycling's published guidelines; (f) to damage caused by service, modifications or alterations performed by anyone other than Stages Indoor Cycling or an authorized Stages Indoor Cycling Service Provider (h) to defects caused by normal wear and tear or otherwise due to the normal aging of the Stages Cycling Product, or (i) if any serial number has been removed or defaced from the Stages Cycling Product.

IMPORTANT RESTRICTION

Stages Indoor Cycling may restrict warranty service to the country where Stages Indoor Cycling or its Authorized Distributors originally sold the Stages Cycling Product.



STAGES[®]
C Y C L I N G

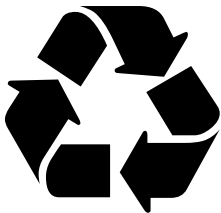

**PLEASE
RECYCLE**

Printed using soy ink on 30% recycled, acid free paper