

Thank you for purchasing the **Office Storage Island**. Before you begin to assemble your new piece of furniture, please check to ensure that all hardware and parts have been supplied. This page lists all contents included in the carton(s).

Follow instructions closely as deviation from them may present a possible safety risk and may void your warranty.

It is recommended that assembly is done on a soft surface such as carpet to avoid any damage.

If you experience any problems with your new purchase please phone Freedom Customer Service (FCS) on 1300 135 588. Customers outside Australia should contact their closest Freedom store.

## Care Information

Periodically check and re-tighten any fasteners. Avoid direct sunlight. Dust the surface weekly using a soft cloth. Please note that high gloss surfaces are delicate and with everyday use you must expect some visual signs of wear on the surface of the product. It is important to remove moist substances immediately. Remove stains with a soft cloth to avoid marks on the surface.

## Hardware (Supplied)



Part A x 27



Part B x 27



Part C x 22

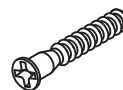

Part D x 11



Part E x 6

## Tools Required (Not Supplied)

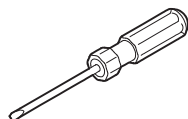

Flat Head Screwdriver

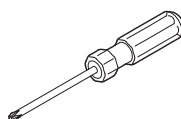

Phillips Head Screwdriver

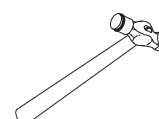

Hammer

## Parts

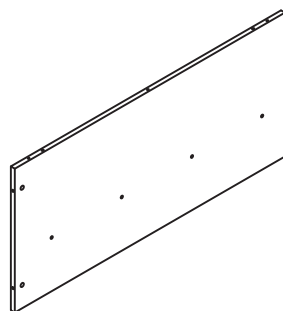

Part F x 1

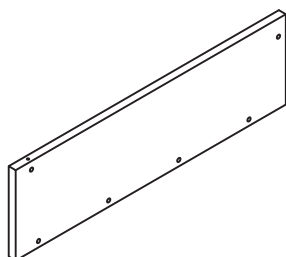

Part G x 2

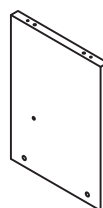

Part H x 2



Part I x 2

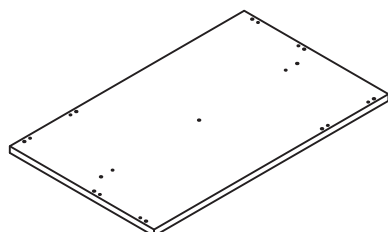

Part J x 1

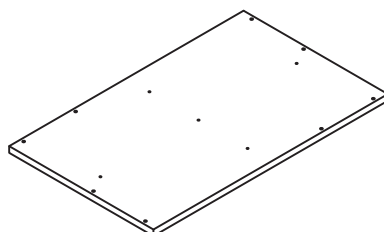

Part K x 1

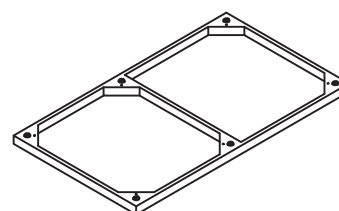

Part L x 1

## Step 1.

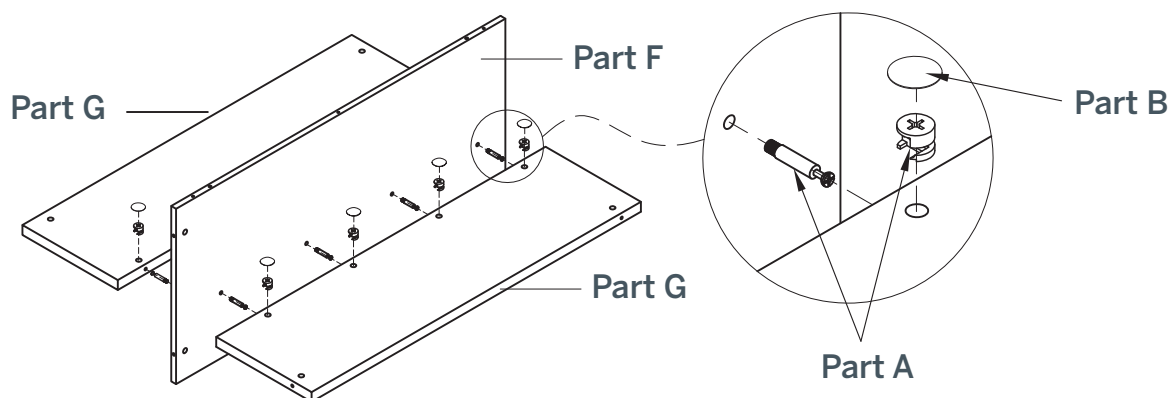

## Step 2.

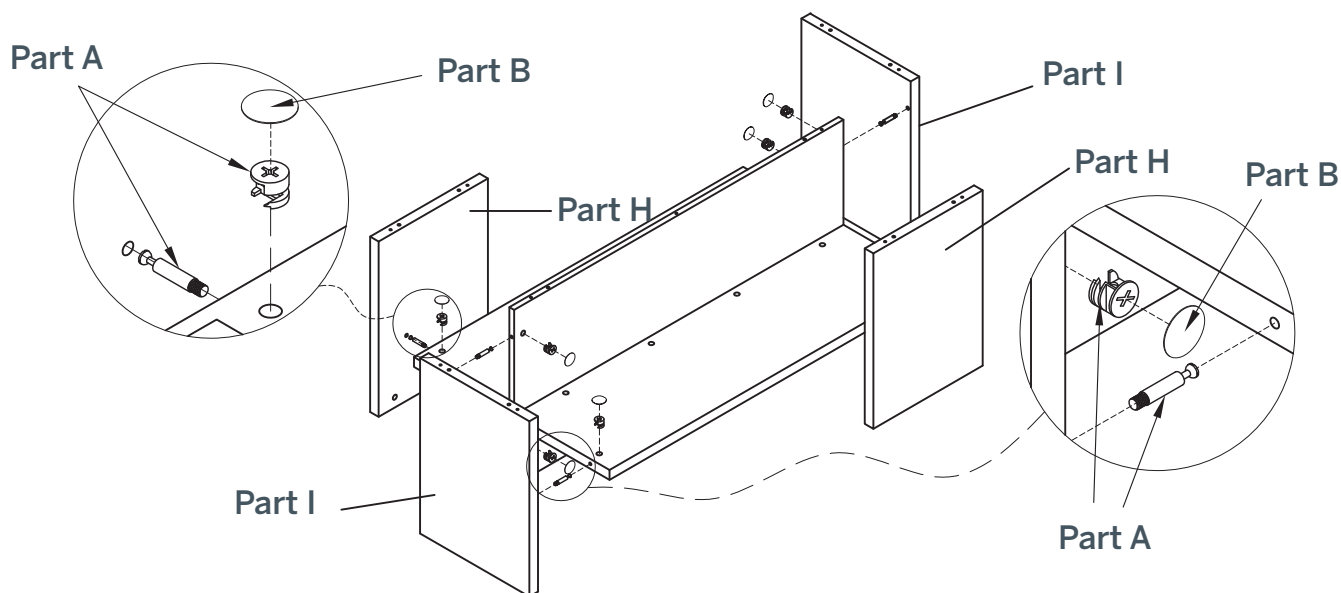

## Step 3.

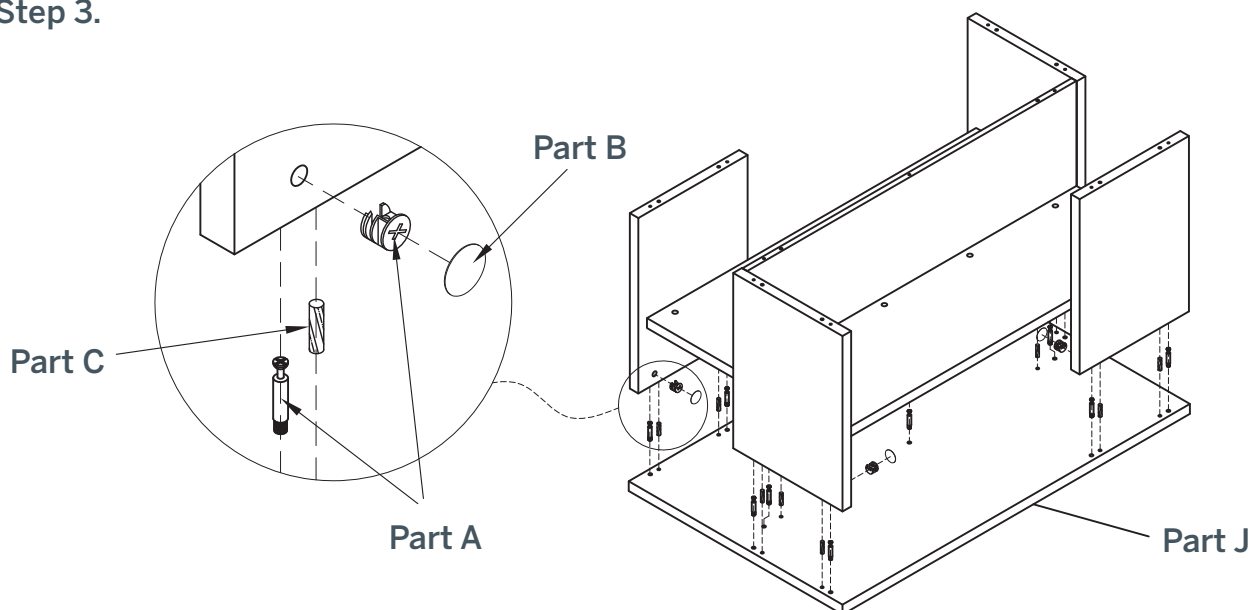

Step 4.

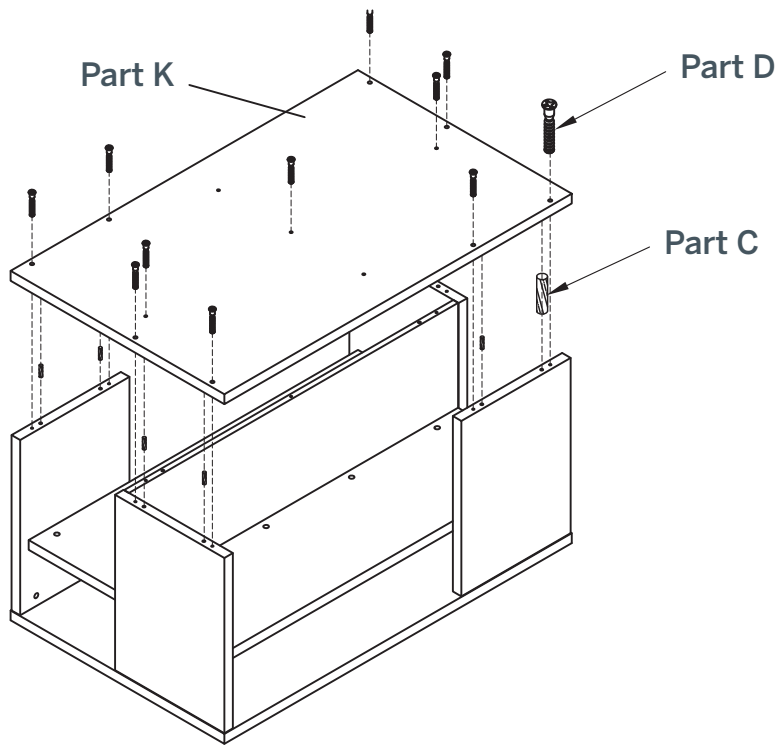

Step 5.

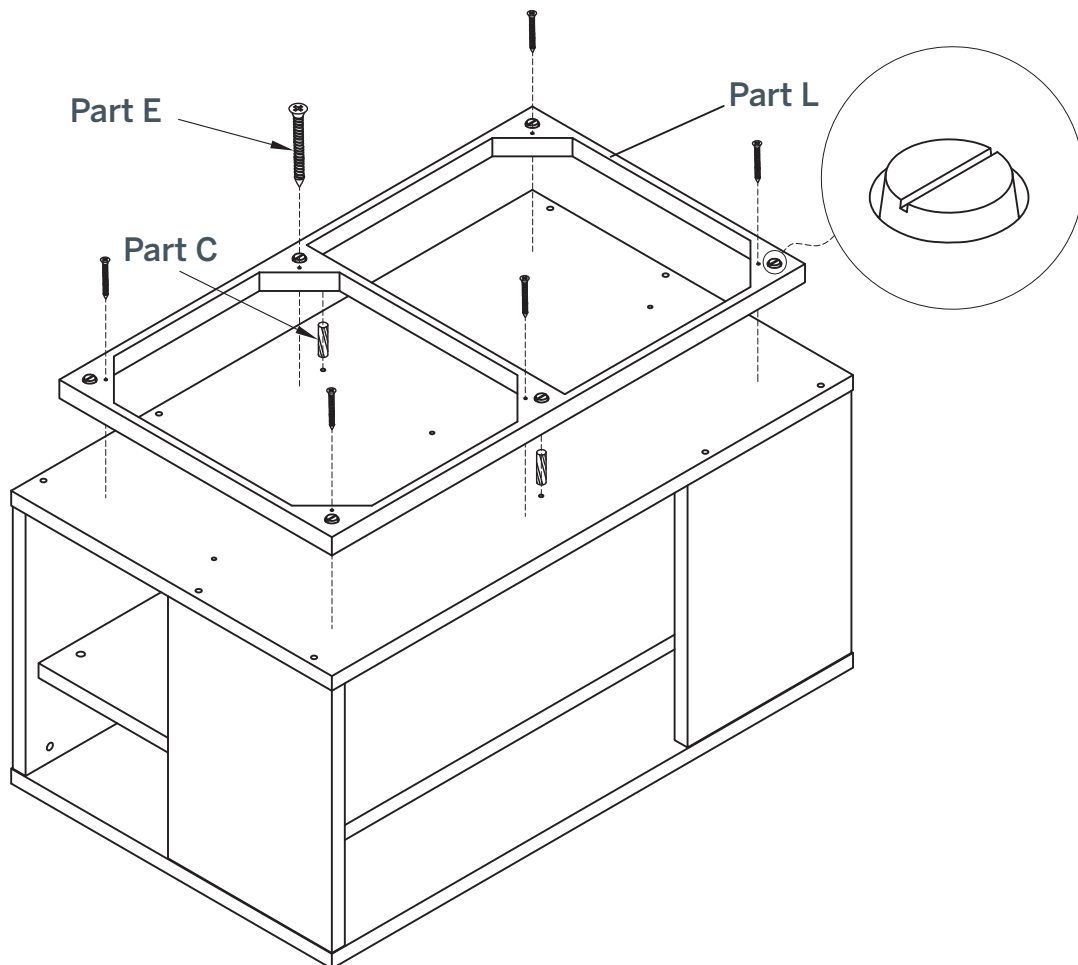

# Office Storage Island

23284272

Finished.

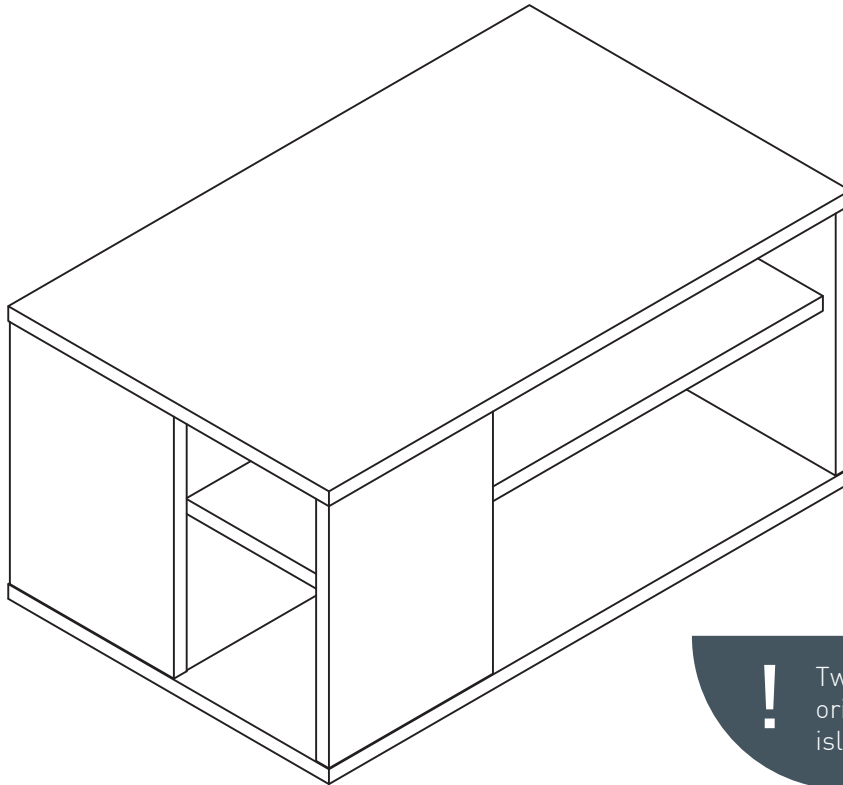

Two people required to orientate the storage island onto its base.