

Assembly Instructions

Zed Desk

- Before you begin to assemble your piece of furniture, please check to ensure that all parts have been supplied.
- Follow instructions closely as deviation from them may void your warranty and present a possible safety risk.
- It is recommended that assembly is done on a soft surface like carpet to avoid any damage.
- If you experience any problems with your new purchase please phone our Customer Service Hotline 1800 807 416 (Customers outside Australia should contact their closest Freedom store.)

Care Information:

Periodically check and re-tighten any fasteners. Wipe down all surfaces weekly with a clean cloth.

Do not clean with harsh abrasives or chemicals.

Clean Glass using a recognised glass cleaning product. Avoid any overspray. Although Tempered Glass is stronger than normal glass it must still be treated with care.

Hardware

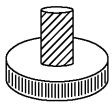

4 X Part A

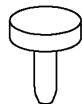

6 X Part B

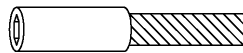

6 X Part C



1 X Part D

Parts

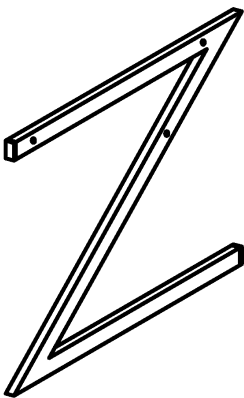

1 X Part E (Left Side)

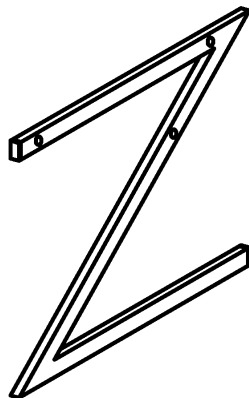

1 X Part F (Right Side)



2 X Part H

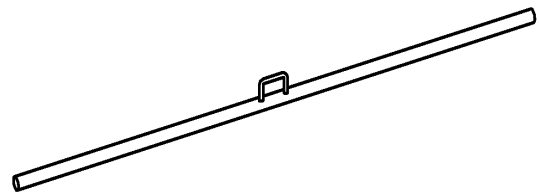

1 X Part I

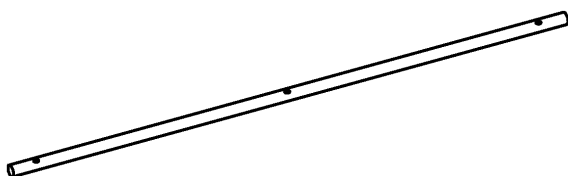

2 X Part G

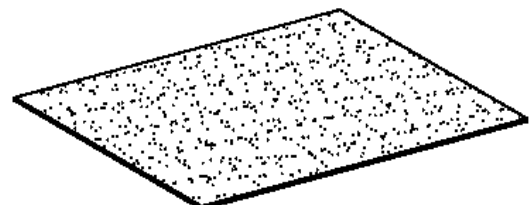

1 X Part J

Assembly Instructions

Zed Desk

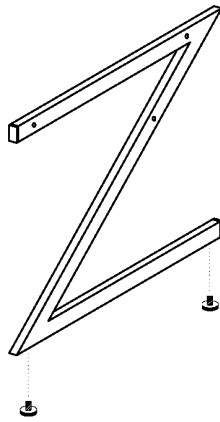

Step 1.

-Screw the 4 Part A into the bottom of the Left and Right sides.

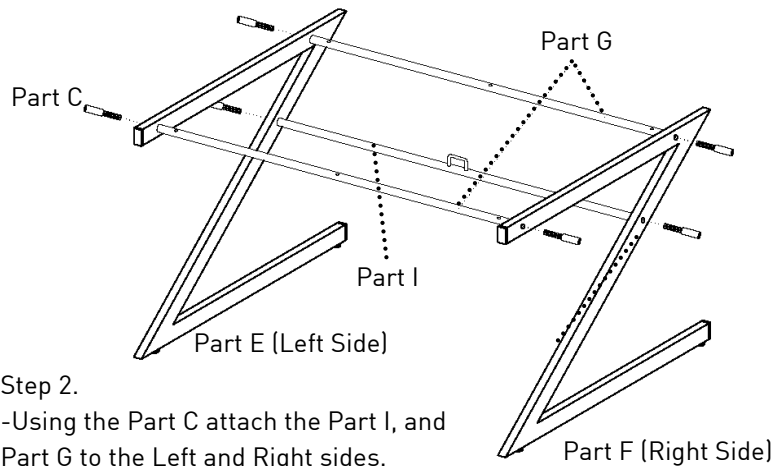

Step 2.

-Using the Part C attach the Part I, and Part G to the Left and Right sides.
BIG HOLD FCAE outside

Note: Remove any plastic caps that are on the rods before assembly.

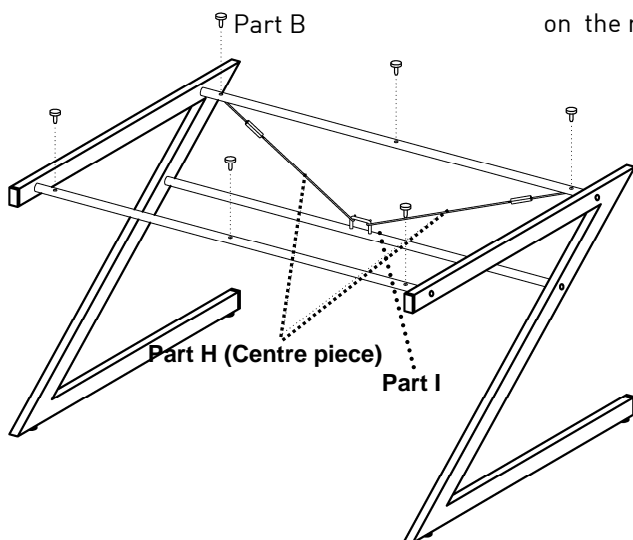

-Hook Part H onto Part I.

By screwing the Part H (Centre piece), slot the hook into Part G holes.

Tighten the Part H by twisting the Part H (centre piece).

-Insert the 6 Part C into holes on Part G.

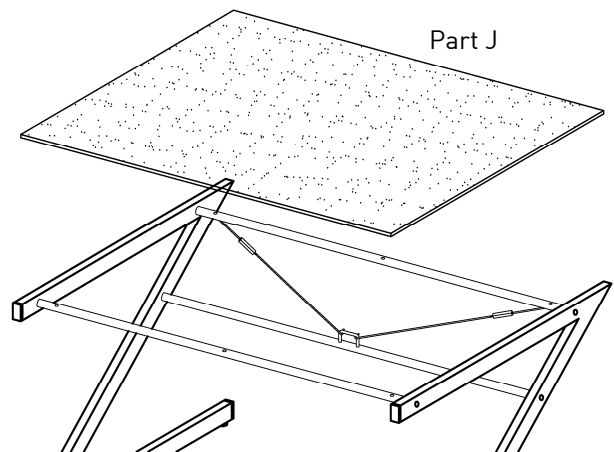

Step 4.

-Carefully locate Part J onto the Part B.

-Once all pieces are together firmly tighten all screws. Leave desk by Part A.

Finished :

