

FREEMOTION[®] treadmill t7.5

Model No. VMTL83607.1

Serial No. _____

Write the serial number in the space above for future reference.

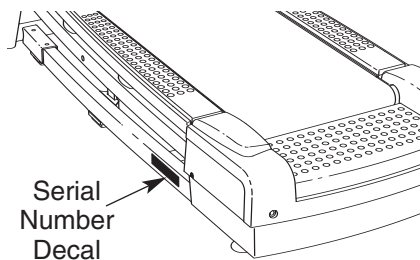

USER'S MANUAL

QUESTIONS?

At FreeMotion Fitness, we are committed to providing complete customer satisfaction. If you have questions, or if parts are damaged or missing, **PLEASE CONTACT THE STORE WHERE YOU PURCHASED THIS PRODUCT.**

If you are unable to contact the store, please see HOW TO CONTACT CUSTOMER CARE on page 2.

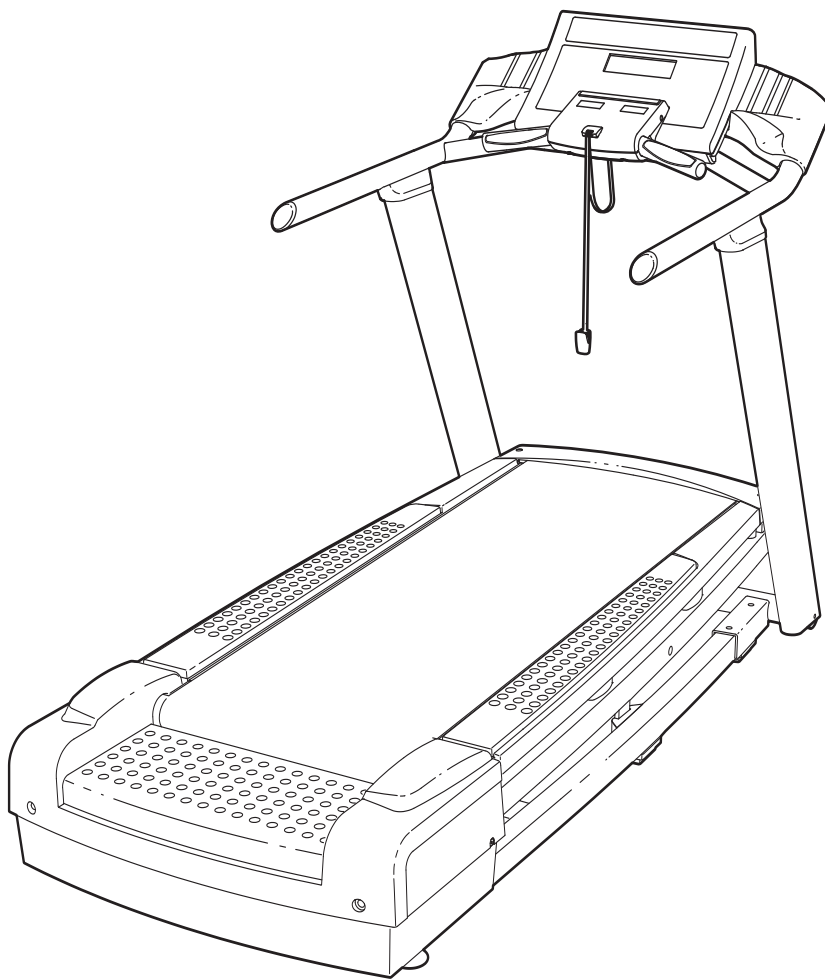

CAUTION

Read all precautions and instructions in this manual before using this equipment. Keep this manual for future reference.



Visit our website at

www.freemotionfitness.com

TABLE OF CONTENTS

	How to Contact Customer Care	2
SECTION 1		
	Important Precautions	3
	Warning Decal Placement	5
	Before You Begin	6
	Assembly	7
	How to Move the Treadmill	12
SECTION 2		
	Treadmill Operation	13
	How to Upgrade the Console	14
SECTION 3		
	Preventive Maintenance	25
	Six-month Preventive Maintenance Record	28
	Troubleshooting	29
SECTION 4		
	Exercise Guidelines	31
SECTION 5		
	Limited Warranty	33
	Part List	34
	Exploded Drawing	36

HOW TO CONTACT CUSTOMER CARE

If you have questions after reading this manual, if you require assistance, or if you need to order replacement parts, please contact Customer Care at the address or phone number listed below. Please be prepared to provide the following information:

- the model number and serial number of the product (see the front cover of this manual)
- the name of the product (see the front cover of this manual)

When ordering replacement parts, please also provide the KEY NUMBER and DESCRIPTION of the part(s) (see the PART LIST and the EXPLODED DRAWING near the end of this manual).

Call

Toll-free in the US: 1-866-799-8946, Mon.–Fri. 8 a.m.–5 p.m. MST

International: +1-719-533-2911

Email

US: fmvcustomerservice@freemotionfitness.com

International: intlcustomercare@freemotionfitness.com

Write

FreeMotion Fitness

1096 Elkton Drive Suite 600

Colorado Springs, CO 80907

IMPORTANT PRECAUTIONS

⚠ WARNING: To reduce the risk of serious injury, read all important precautions and instructions in this manual and all warnings on your treadmill before using your treadmill. FREEMOTION FITNESS assumes no responsibility for personal injury or property damage sustained by or through the use of this product.

1. Before beginning any exercise program, consult your physician. This is especially important for persons over the age of 35 or persons with pre-existing health problems.
2. It is the responsibility of the owner to ensure that all users of the treadmill are adequately informed of all warnings and precautions.
3. Use the treadmill only as described in this manual.
4. Place the treadmill on a level surface, with at least 8 ft. (2.4 m) of clearance behind it and 2 ft. (0.6 m) on each side. Do not place the treadmill on any surface that blocks air openings. To protect the floor or carpet from damage, place a mat under the treadmill.
5. Keep the treadmill indoors, away from moisture and dust. Do not place the treadmill in a garage or covered patio, or near water.
6. Do not operate the treadmill where aerosol products are used or where oxygen is being administered.
7. Do not operate the treadmill until it is properly assembled (see ASSEMBLY on page 7).
8. Inspect and properly tighten all parts of the treadmill regularly.
9. Keep children under the age of 12 and pets away from the treadmill at all times.
10. The treadmill should not be used by persons weighing more than 350 lbs. (159 kg). Do not allow more than one person on the treadmill at a time.
11. Wear appropriate exercise clothes when using the treadmill. Do not wear loose clothes that could become caught in the treadmill. Athletic support clothes are recommended for both men and women. *Always wear athletic shoes. Never use the treadmill with bare feet, wearing only stockings, or in sandals.*
12. When connecting the power cord (see page 13), plug the power cord into a surge suppressor (not included) and plug the surge suppressor into a grounded circuit capable of carrying 15 or more amps. No other appliance should be on the same circuit. Do not use an extension cord.
13. Use only a single-outlet surge suppressor that meets all the specifications described on page 13. To purchase a surge suppressor, contact the store where you purchased this product, or see your local electronics store. If you are unable to contact a store, please see HOW TO CONTACT CUSTOMER CARE on page 2 and order part number 146148.
14. Failure to use a properly functioning surge suppressor could result in damage to the control system of the treadmill. If the control system is damaged, the walking belt may change speed, accelerate, or stop unexpectedly, which may result in a fall and serious injury.
15. Keep the power cord and the surge suppressor away from heated surfaces.
16. Never move the walking belt while the power is turned off. Do not operate the treadmill if the power cord or plug is damaged or if the treadmill is not working properly. (See TROUBLESHOOTING on page 29 if the treadmill is not working properly.)
17. Read, understand, and test the emergency stop procedure before using the treadmill (see page 16).
18. Never start the treadmill while you are standing on the walking belt. Always hold the handrails while using the treadmill.
19. The treadmill is capable of high speeds. Adjust the speed in small increments to avoid sudden jumps in speed.

20. Never leave the treadmill unattended while it is running. Always remove the key, unplug the power cord, and move the reset/off circuit breaker to the “off” position when the treadmill is not in use. (See the drawing on page 6 for the location of the reset/off circuit breaker.)
21. Do not change the incline of the treadmill by placing objects under it.
22. Never insert or drop any object into any opening on the treadmill.
23. Make sure to perform all maintenance procedures outlined in this manual. Failure to do so will void the warranty and may result in damage to the treadmill.
24. **DANGER:** Always unplug the power cord immediately after use, before cleaning the treadmill, and before performing the maintenance and adjustment procedures described in this manual. Servicing other than the procedures in this manual should be performed by an authorized service representative only.
25. The treadmill is intended for in-home use or light commercial use only. Do not use the treadmill in a commercial, rental, or institutional setting.

SAVE THESE INSTRUCTIONS

WARNING DECAL PLACEMENT

The decal shown here has been applied in the indicated locations. **If the decal is missing or illegible, see the front cover of this manual and request a free replacement decal. Apply the decal in the location shown.** Note: The decal may not be shown at actual size.

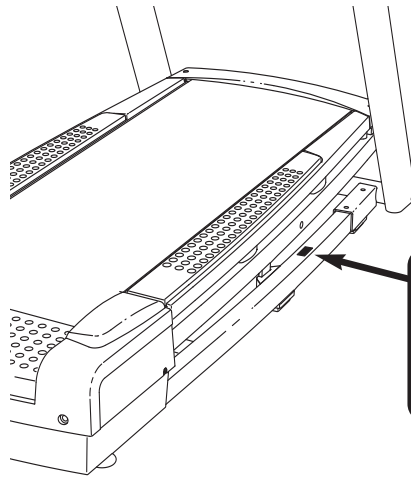

CAUTION

KEEP HANDS AND FEET AWAY FROM THIS AREA WHILE THE TREADMILL IS IN OPERATION.

Note: There is one decal on each side.

BEFORE YOU BEGIN

Congratulations for selecting the revolutionary FREEMOTION® t7.5 treadmill. The t7.5 treadmill offers an impressive array of features designed to help you achieve your fitness goals in the convenience and privacy of your home.

For your benefit, read this manual carefully before using the treadmill. If you have questions after read-

ing this manual, please see the front cover of this manual. To help us assist you, note the product model number and serial number before contacting us. The model number and the location of the serial number decal are shown on the front cover of this manual.

Before reading further, please familiarize yourself with the parts that are labeled in the drawing below.

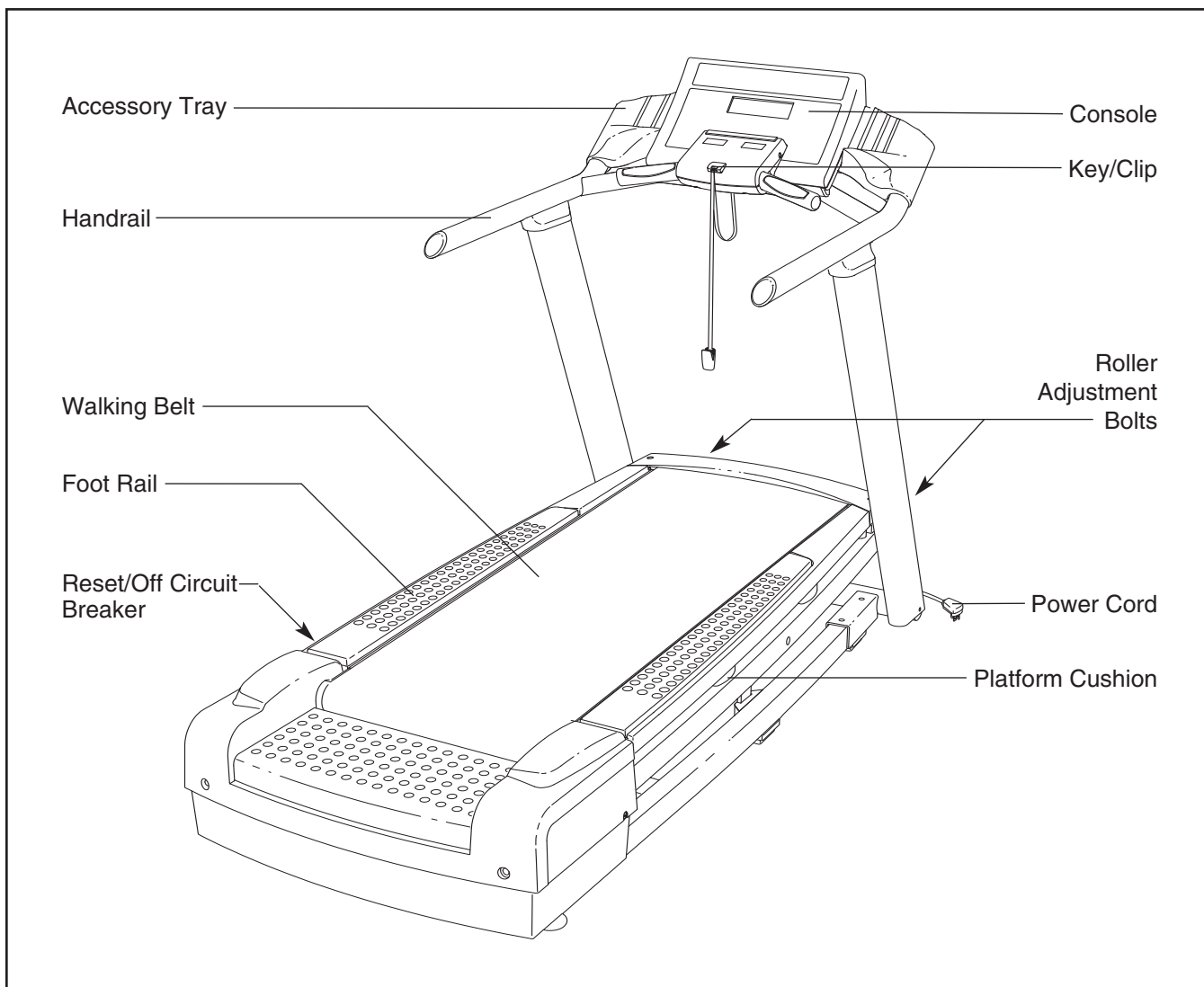

ASSEMBLY

Assembly requires two persons. Set the treadmill in a cleared area and remove all packing materials. Do not dispose of the packing materials until assembly is completed. **Assembly can be completed using the included hex key and your own adjustable wrench**  .

Note: The underside of the treadmill walking belt is coated with high-performance lubricant. During shipping, a small amount of lubricant may be transferred to the top of the walking belt or the shipping carton. This is a normal condition and does not affect treadmill performance. If there is lubricant on top of the walking belt, simply wipe off the lubricant with a soft cloth and a mild, non-abrasive cleaner.

Use the drawings below to identify the assembly hardware. The number in parentheses below each drawing is the key number of the part, from the PART LIST near the end of this manual. The number after the parentheses shows the quantity needed for assembly. **Note: If a part is not in the parts bag, check to see if it is pre-attached to one of the parts to be assembled. Extra hardware may be included. To avoid damaging plastic parts, do not use power tools for assembly.**

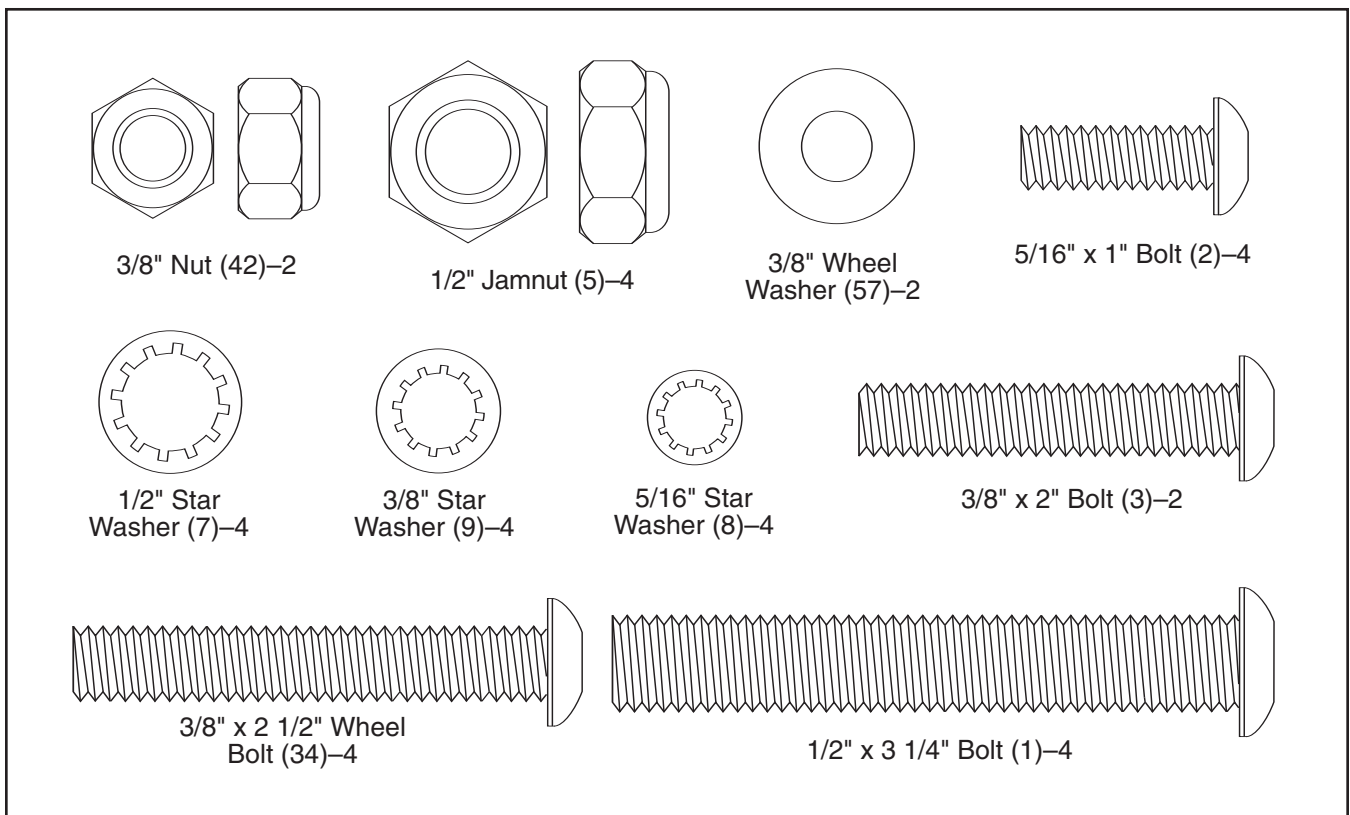

1. Place the Uprights (96) near the front of the Base Frame (75) as shown.

Connect the 80" Wire Harness (46) in the Base Frame (75) to the 55" Wire Harness (48) in the right Upright (96). **See the inset drawing. The connectors should slide together easily and snap into place.** If they do not, turn one connector and try again. **IF THE CONNECTORS ARE NOT INSERTED PROPERLY, THE CONSOLE MAY BE DAMAGED WHEN THE POWER IS TURNED ON.**

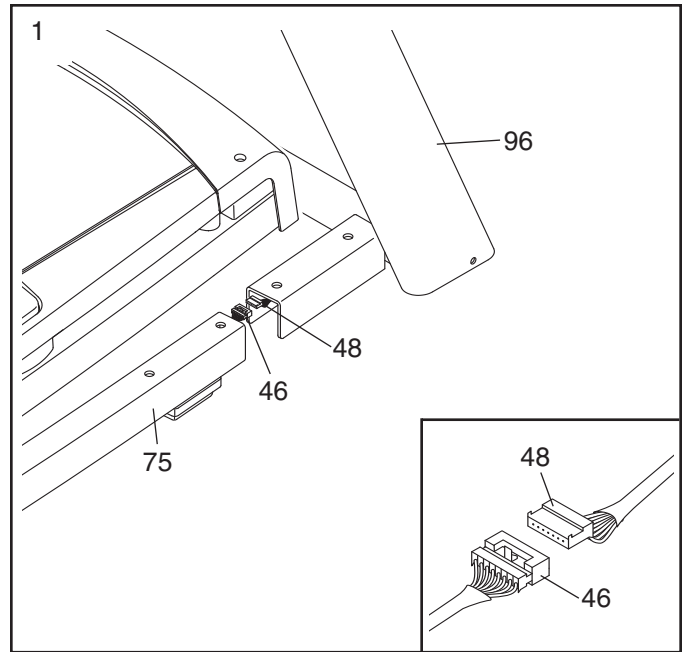

2. With the help of a second person, align the indicated holes in the Uprights (96) above the holes in the Base Frame (75), and slide the Uprights down onto the Base Frame. **Be careful not to pinch the wires.** Make sure to keep the holes aligned.

Tighten four 1/2" x 3 1/4" Bolts (1) with four 1/2" Star Washers (7) and four 1/2" Jamnuts (5) (only two of each are shown) into the Uprights (96) and the Base Frame (75). **Start all four Bolts before tightening any of them.**

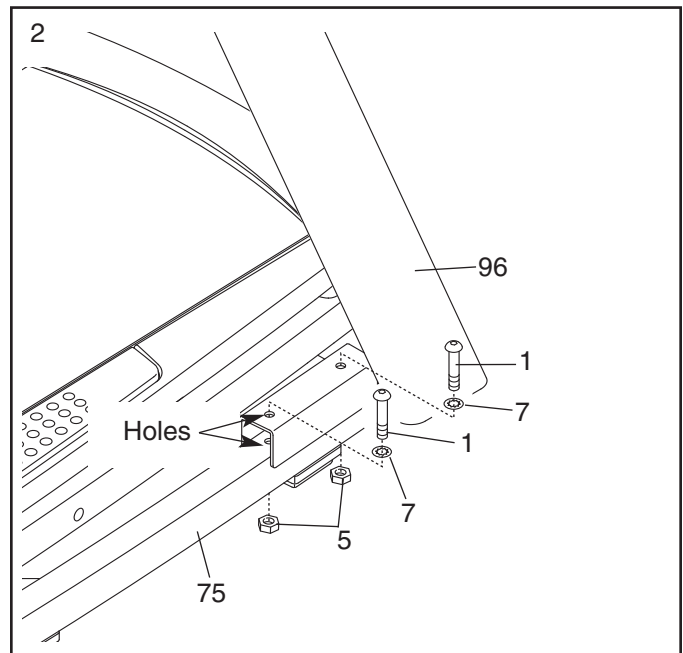

3. **The Wheels (91) may be preattached. If they are not, complete this step.**

With the help of a second person, carefully raise the Uprights (96) and insert a Wheel (91) inside the bottom of each Upright.

Attach the Wheels (91) with two 3/8" x 2 1/2" Wheel Bolts (34), two 3/8" Wheel Washers (57), and two 3/8" Nuts (42) (only one of each is shown). **Do not overtighten the Nuts; the Wheels must turn freely.**

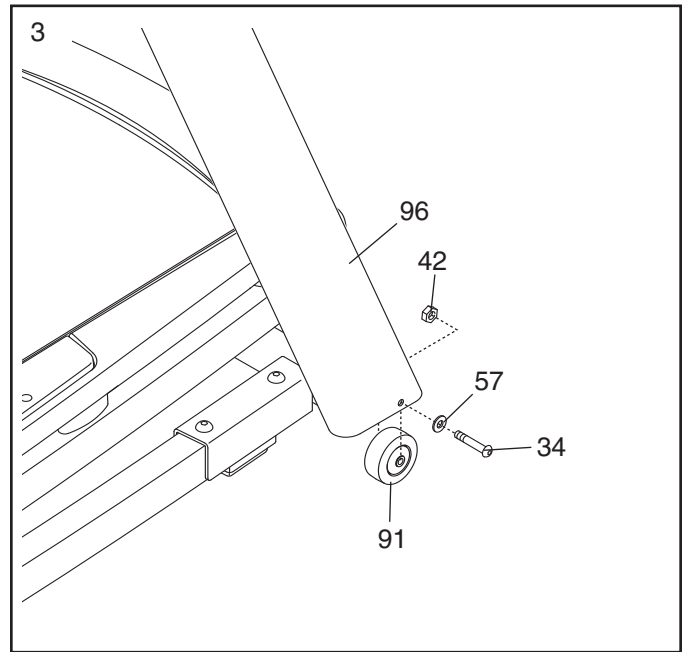

4. **The Upright Brackets (98, 99) may be preattached. If they are not, complete this step.**

Insert the TV cables through the Left Upright Bracket (99). Press the Left Upright Bracket onto the left Upright (96). **Be careful not to pinch the wires.**

Insert the 55" Wire Harness (48) through the Right Upright Bracket (98). Press the Right Upright Bracket onto the right Upright (96). **Be careful not to pinch the Wire Harness.**

Attach the Upright Brackets (98, 99) with four 3/8" x 2" Bolts (3) and four 3/8" Star Washers (9).

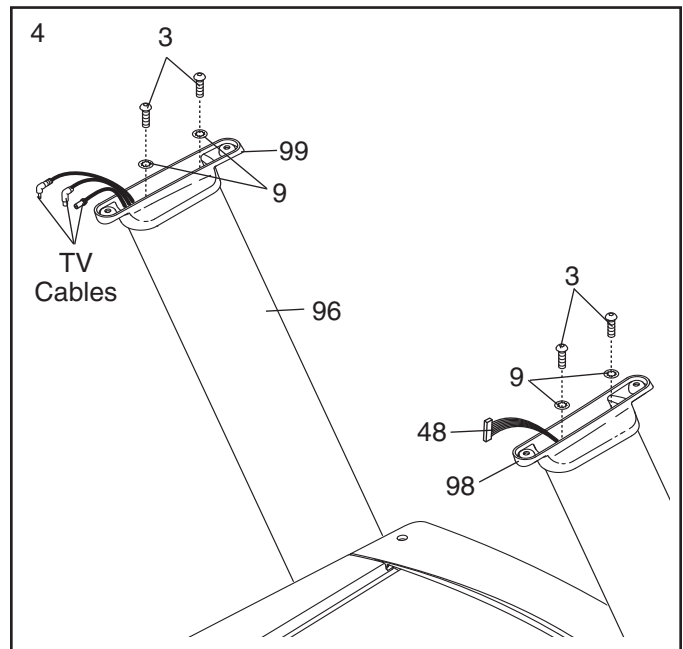

5. Have a second person hold the Handrail (100) near the Upright Brackets (98, 99). Connect the TV cables in the Handrail to the TV cables in the Left Upright Bracket.

Connect the 55" Wire Harness (48) in the Right Upright Bracket (98) to the 35" Wire Harness (47). **See the inset drawing in step 1. The connectors should slide together easily and snap into place.** If they do not, turn once connector and try again. **IF THE CONNECTORS ARE NOT INSERTED PROPERLY, THE CONSOLE MAY BE DAMAGED WHEN THE POWER IS TURNED ON.**

Attach the Handrail (100) to the Upright Brackets (98, 99) with four 5/16" x 1" Bolts (2) and four 5/16" Star Washers (8). **Start all four Bolts before tightening any of them. Be careful not to pinch the wires.**

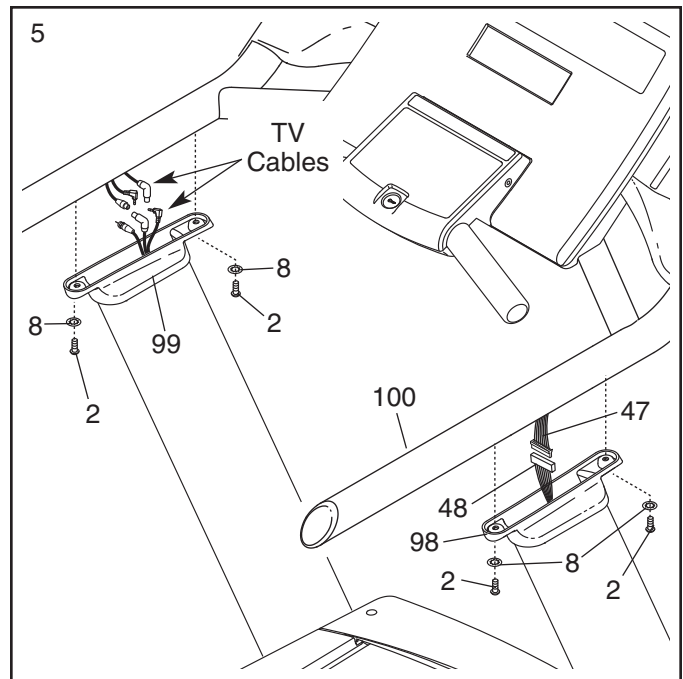

6. **Make sure that all parts are properly tightened before you use the treadmill.** To protect the floor or carpet, place a mat beneath the treadmill.

If you purchased the optional personal television, follow the steps below.

7. Remove the three #8 x 1/2" Console Cover Screw (121) from the Console Cover (105). Discard the Console Cover.

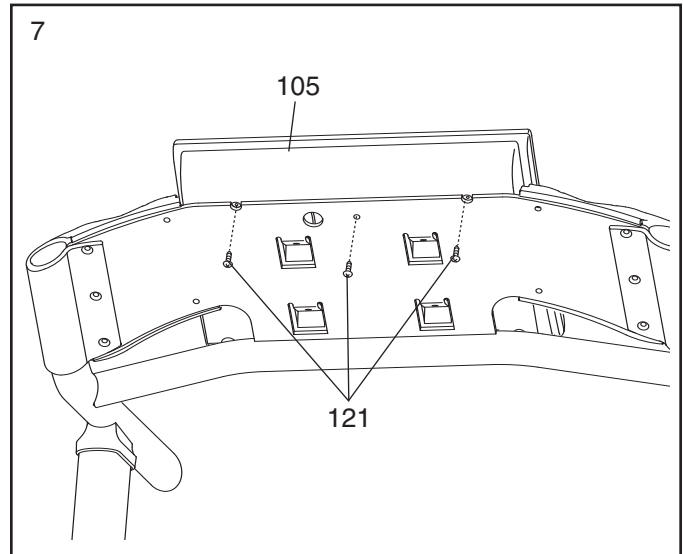

8. Have a second person hold the TV Console (138) near the Console Back (49). Connect the TV cable (A) in the TV Console to the 45" TV Cable (125) in the Console Back.

Connect the wire harness (B) in the TV Console (138) to the wire harness (C) in the Console Back (138). **See the inset drawing in step 1. The connectors should slide easily and snap into place.** If they do not, turn one connector and try again. **IF THE CONNECTORS ARE NOT INSERTED PROPERLY, THE CONSOLE MAY BE DAMAGED WHEN THE POWER IS TURNED ON.**

Attach the TV Console (138) to the Console Back (49) with the #8 x 1/2" Console Cover Screws (121) you removed in step 5. **Be careful not to pinch the wires.**

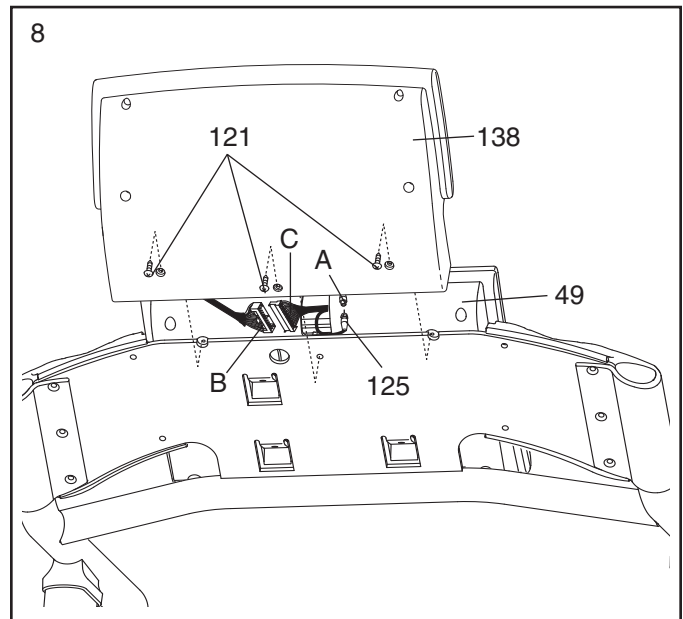

HOW TO MOVE THE TREADMILL

Before moving the treadmill, unplug the power cord.

Due to the size and weight of the treadmill, moving it requires two or three persons. Hold the metal frame firmly in the location shown at the right. **CAUTION: To decrease the possibility of damage to the treadmill or of injury, do not lift the frame by the plastic front cover or by the handrail.** Carefully roll the treadmill on the wheels to the desired location and then lower it to the level position. **CAUTION: To reduce the risk of injury, use extreme caution while moving the treadmill. Do not attempt to move the treadmill over uneven surfaces.**

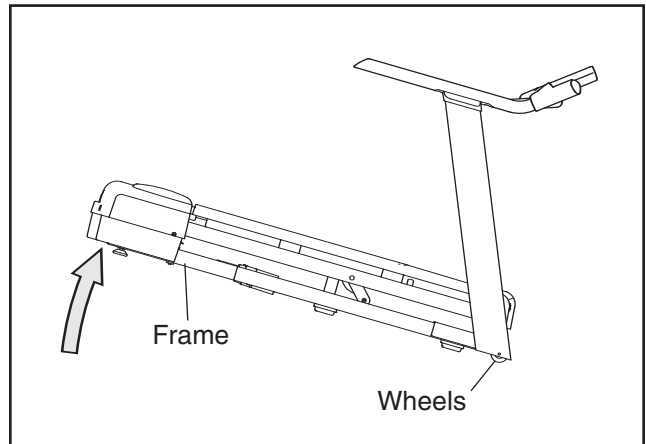

After the treadmill is placed in the location where it will be used, make sure that both leveling feet and the base pads rest firmly on the floor (only one side is shown). If the treadmill rocks even slightly, turn one of the leveling feet clockwise or counterclockwise until the rocking motion is eliminated.

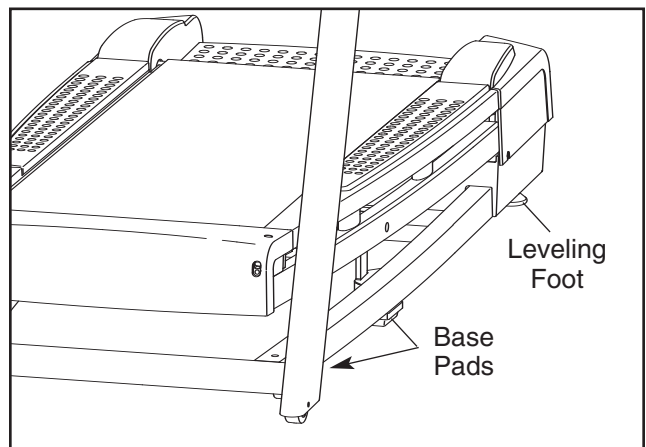

TREADMILL OPERATION

THE PRE-LUBRICATED WALKING BELT

Your treadmill features a walking belt coated with high-performance lubricant. **IMPORTANT: Never apply substances to the walking belt or the walking platform. Silicone spray and other substances will deteriorate the walking belt and cause excessive wear.**

⚠ DANGER: Improper connection of the equipment-grounding conductor can result in an increased risk of electric shock. Check with a qualified electrician or serviceman if you are in doubt as to whether the product is properly grounded. Do not modify the plug provided with the product—if it will not fit the outlet, have a proper outlet installed by a qualified electrician.

HOW TO PLUG IN THE POWER CORD

Your treadmill, like any other type of sophisticated electronic equipment, can be seriously damaged by sudden voltage changes in your home's power. Voltage surges, spikes, and noise interference can result from weather conditions or from other appliances being turned on or off. **To decrease the possibility of your treadmill being damaged, always use a surge suppressor with your treadmill (see drawing 1 at the right). To purchase a surge suppressor, contact the store where you purchased this product, or see your local electronics store. If you are unable to contact a store, please see HOW TO CONTACT CUSTOMER CARE on page 2 and order part number 146148.**

Use only a single-outlet surge suppressor that is UL 1449 listed as a transient voltage surge suppressor (TVSS). The surge suppressor must have a UL suppressed voltage rating of 400 volts or less and a minimum surge dissipation of 450 joules. The surge suppressor must be electrically rated for 120 volts AC and 15 amps. There must be a monitoring light on the surge suppressor to indicate whether it is functioning properly. Failure to use a properly functioning surge suppressor could result in damage to the control system of the treadmill. If the control system is damaged, the walking belt may change speed, accelerate, or stop unexpectedly, which may result in a fall and serious injury.

This product must be grounded. If it should malfunction or break down, grounding provides a path of least

resistance for electric current to reduce the risk of electric shock. This product is equipped with a cord having an equipment-grounding conductor and a grounding plug. **Plug the power cord into a surge suppressor, and plug the surge suppressor into an appropriate outlet that is properly installed and grounded in accordance with all local codes and ordinances. IMPORTANT: The treadmill is not compatible with GFCI-equipped outlets.**

This product is for use on a nominal 120-volt circuit, and has a grounding plug that looks like the plug illustrated in drawing 1 below. A temporary adapter that looks like the adapter illustrated in drawing 2 may be used to connect the surge suppressor to a 2-pole receptacle as shown in drawing 2 if a properly grounded outlet is not available.

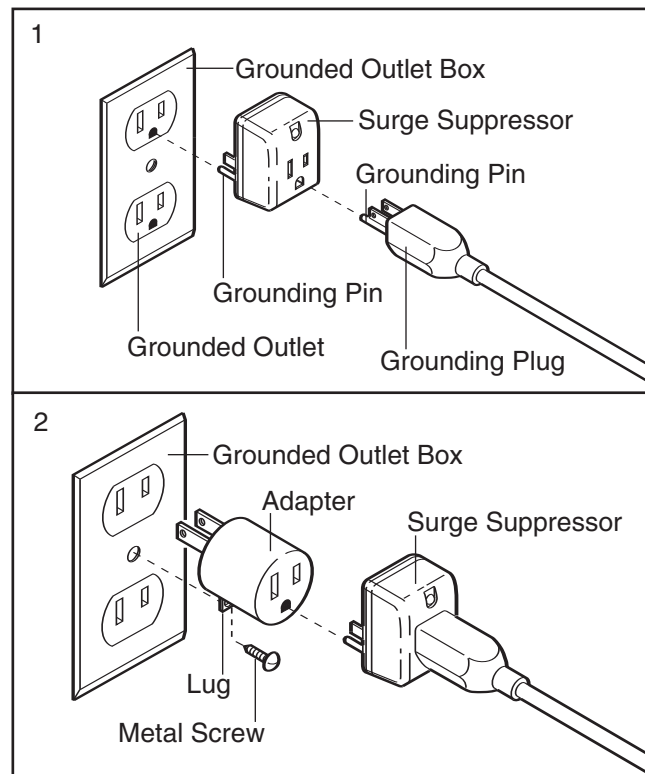

The temporary adapter should be used only until a properly grounded outlet (drawing 1) can be installed by a qualified electrician.

The green-colored rigid ear, lug, or the like extending from the adapter must be connected to a permanent ground such as a properly grounded outlet box cover. Whenever the adapter is used it must be held in place by a metal screw. **Some 2-pole receptacle outlet box covers are not grounded. Contact a qualified electrician to determine if the outlet box cover is grounded before using an adapter.**

HOW TO UPGRADE THE CONSOLE

This console features an optional personal television, which offers additional functionality. With the optional personal television, you can watch the television programs of your choice, or connect and use your own VCR or DVD player. To purchase the optional personal television, please see the front cover of this manual.

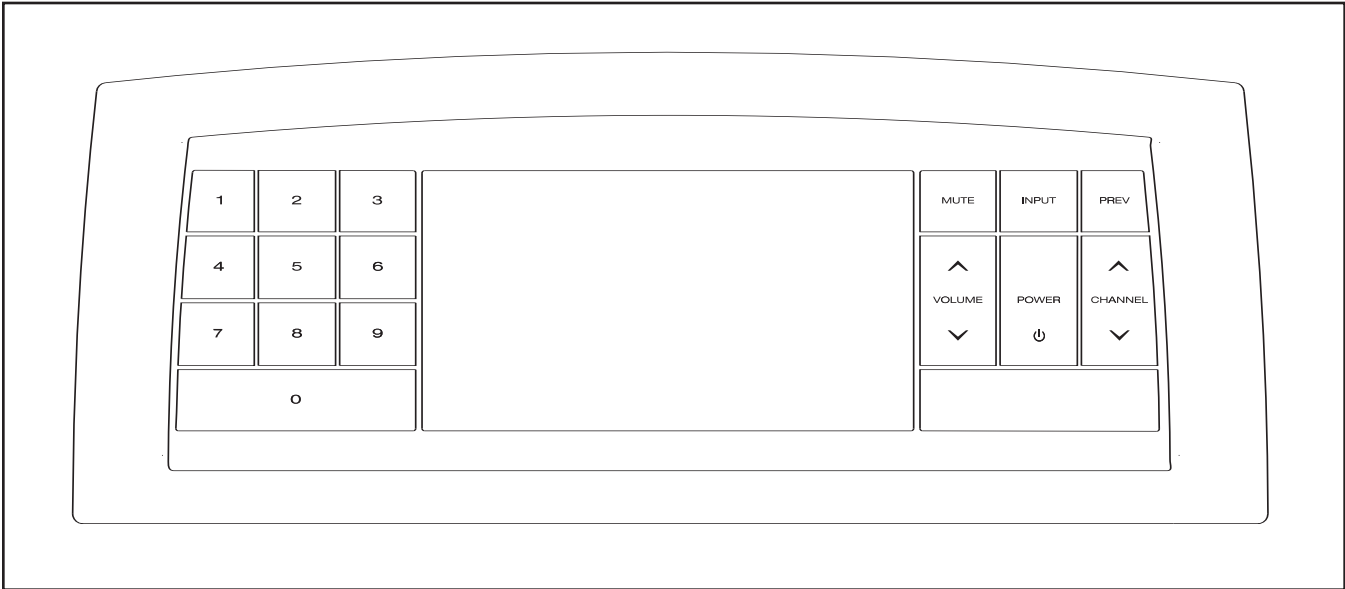

CONSOLE DIAGRAM

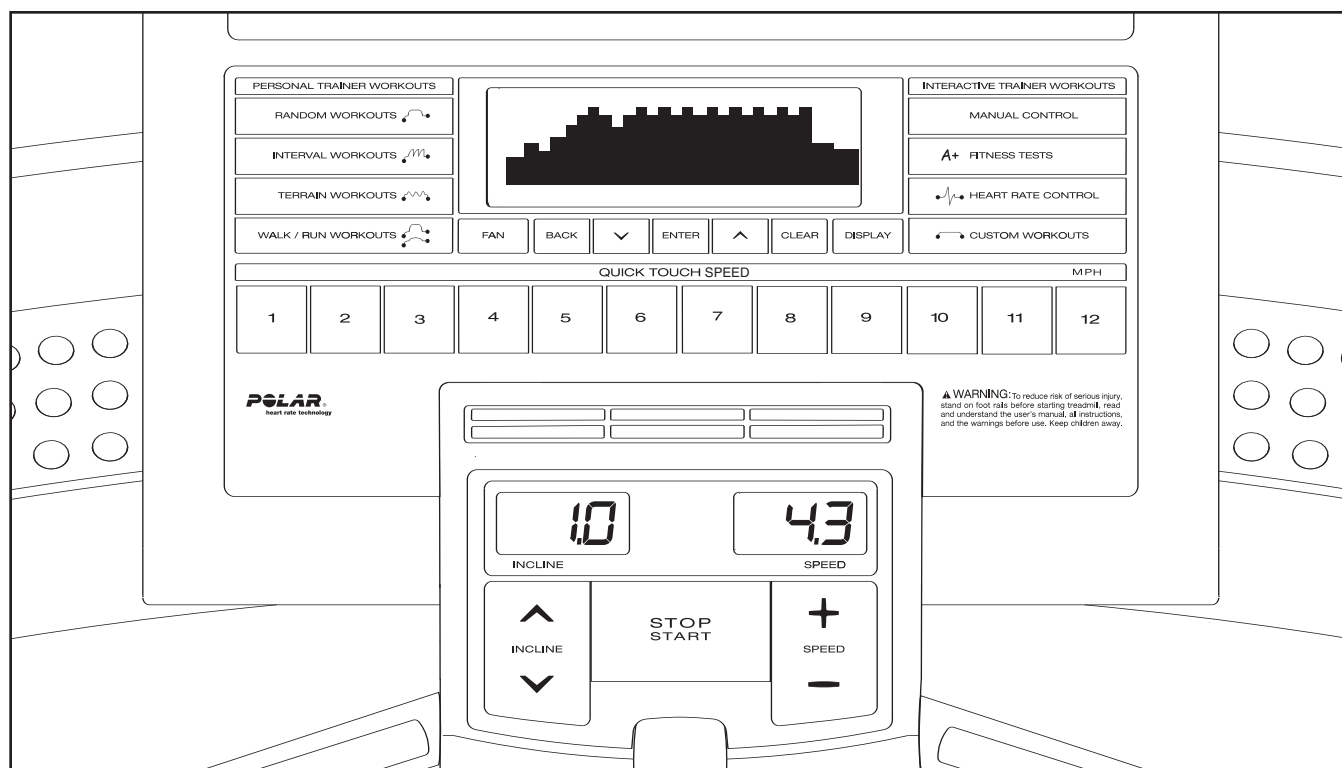

FEATURES OF THE CONSOLE

The treadmill console offers an impressive array of features designed to make your workouts more effective and enjoyable. When you use the manual mode of the console, you can change the speed and incline of the treadmill with the touch of a button. As you exercise, the console will display continuous exercise feedback.

In addition, the console features fourteen personal trainer workouts. Each preset workout automatically controls the speed and incline of the treadmill as it guides you through an effective workout.

The console also offers twelve interactive trainer workouts that allow you to customize your workout. The interactive trainer workouts include three heart rate workouts that control the speed and incline of the treadmill to keep your heart rate near the target heart rate settings. In addition, three fitness test workouts measure your fitness level or your VO₂ max.

The console also features the new iFIT Interactive Workout system. The iFIT system is compatible with iFIT Interactive Workout Cards containing workout pro-

grams designed to help you achieve specific fitness goals. For example, lose unwanted pounds with the iFIT Weight Loss program, or train for a long-distance run with the iFIT Marathon program. iFIT programs automatically control the speed and incline of the treadmill. **To purchase iFIT cards, please see the front cover of this manual or go to www.iFIT.com. iFIT cards are also available at select stores.**

Whether you select the manual mode or a preset workout, you can watch the television programs of your choice on the optional personal television. You can even listen to your favorite workout music or audio books with the console's stereo sound system.

To turn on the power, follow the steps beginning on page 16. **To use the manual mode**, see page 16. **To use a personal trainer workout**, see page 18. **To use a walk/run workout or a manual control workout**, see page 19. **To use a fitness test workout**, see page 20. **To use a heart rate workout**, see page 21. **To use a custom workout**, see page 22. **To use an iFIT workout**, see page 23. **To use the maintenance mode**, see page 24. **To use the stereo sound system**, see page 24.

HOW TO TURN ON THE POWER

IMPORTANT: If the treadmill has been exposed to cold temperatures, allow it to warm to room temperature before turning on the power. If you do not do this, the console displays or other electrical components may become damaged.

Plug in the power cord (see page 13). Next, locate the reset/off circuit breaker on the treadmill frame near the power cord. Make sure that the circuit breaker is in the “reset” position.

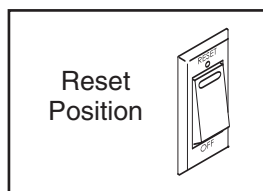

Next, stand on the foot rails of the treadmill. Locate the clip attached to the key (see the drawing at the right), and slide the clip securely onto the waistband of your clothes.

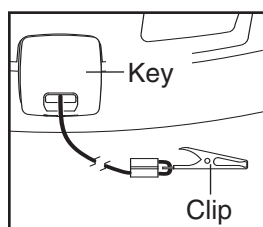

Then, insert the key into the console. After a moment, the displays will light. **IMPORTANT:** In an emergency situation, the key can be pulled from the console, causing the walking belt to slow to a stop. Test the clip by carefully taking a few steps backward; if the key is not pulled from the console, adjust the position of the clip.

IMPORTANT: If there is a sheet of clear plastic on the face of the console, remove the plastic. To prevent damage to the walking platform, wear clean athletic shoes while using the treadmill. The first time the treadmill is used, observe the alignment of the walking belt, and center the walking belt if necessary (see page 30).

Note: Your console will display speed and distance in either miles or kilometers. For simplicity, all instructions in this section refer to miles.

HOW TO USE THE MANUAL MODE

1. Insert the key into the console.

See HOW TO TURN ON THE POWER at the left.

2. Select the manual mode.

Each time the key is inserted, the manual mode will be selected. If you have selected a workout, press any of the workout buttons repeatedly until zeros appear in the display.

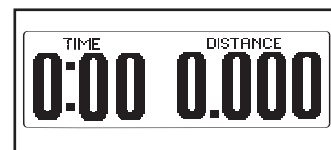

3. Start the walking belt and adjust the speed.

To start the walking belt, press the Start/Stop button, the Speed increase button, or one of the Quick Touch Speed buttons numbered 1 to 12. As you exercise, change the speed of the walking belt as desired by pressing the Speed increase and decrease buttons next to the Start/Stop button. Each time you press a button, the speed setting will change; if you hold down a button, the speed setting will change in larger increments. After you press one of the Quick Touch Speed buttons, press the Enter button or press the speed button again to confirm the speed.

To stop or restart the walking belt, press the Start/Stop button.

4. Change the incline of the treadmill as desired.

To change the incline of the treadmill, press the Incline increase or decrease button. Each time you press one of the buttons, the incline will gradually change until it reaches the selected incline setting.

5. Select a display mode and monitor your progress with the display.

When the manual mode is selected, the console offers seven display modes. The display mode that you select will determine which workout information is shown. Press the Display button repeatedly to select the desired display mode.

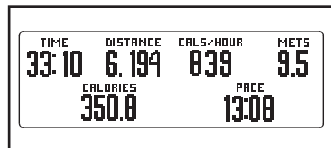

As you walk or run on the treadmill, the upper display can show the following workout information:

- The elapsed time.
- The distance that you have walked or run.
- The speed of the walking belt.
- The incline level of the treadmill.
- The approximate number of calories you have burned.
- The approximate number of calories burned per hour.
- Your exercise intensity in mets. One met is the amount of energy you use while resting.
- Your walking or running pace, in minutes per mile or minutes per kilometer.
- Your power output in watts.
- An animation of a road.

Regardless of which display mode you select, the speed or incline setting will appear in the display for a few seconds each time you change the setting.

As you switch between workouts and the manual mode, the console will keep track of the total distance that you have walked or run and the approximate number of calories you have burned. You can keep your totals even when you switch to a new workout. To reset the console, press the Clear button.

6. Measure your heart rate if desired.

Before using the handgrip pulse sensor, remove the sheets of clear plastic from the metal contacts. In addition, make sure that your hands are clean.

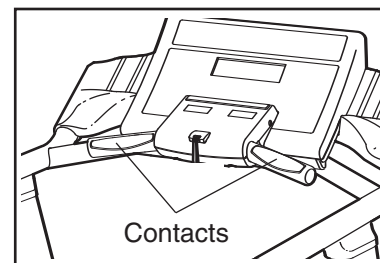

To measure your heart rate, **stand on the foot rails. Hold the contacts for approximately ten seconds—avoid moving your hands.** When your pulse is detected, your heart rate will be shown. **For the most accurate heart rate reading, continue to hold the contacts for about 15 seconds.**

7. Turn on the fan if desired.

The fan has high and low speed settings. Press the Fan button repeatedly to select a fan speed or to turn off the fan. Note: If the fan is on when the walking belt stops, the fan will automatically turn off after a few minutes.

8. When you are finished exercising, remove the key from the console.

Step onto the foot rails, press the Stop button, remove the key from the console, and put it in a secure place.

When you are finished using the treadmill, switch the reset/off circuit breaker to the “off” position and unplug the power cord. **IMPORTANT: If you do not do this, the treadmill’s electrical components may wear prematurely.**

HOW TO USE A PERSONAL TRAINER WORKOUT

1. Insert the key into the console.

See HOW TO TURN ON THE POWER on page 16.

2. Select one of the personal trainer workouts.

To select a personal trainer workout, press the Random Workouts button, the Interval



Workouts button, or the Terrain Workouts button repeatedly until the name of the desired workout appears in the display. Random workouts use preset random speed and incline settings. Interval workouts use speed settings to provide a personalized workout. Terrain workouts use speed and incline settings to simulate an actual walking experience.

When a workout is selected, the display will show the name, the maximum incline setting, the maximum speed setting and the duration of the workout. The display will also show a profile of the speed settings of the workout.

Press the Enter button to select the desired workout. Select your age, your weight, and the workout duration using the Increase and Decrease buttons next to the Enter button. **Press the Enter button after each selection.** Note: To use the Interval workouts, you must also enter your minimum and maximum speed settings using the Quick Touch Speed buttons or the Speed Increase and Decrease buttons.

3. Press the Start/Stop button to start the workout.

A moment after you press the Start/Stop button, the treadmill will automatically adjust to the first speed and incline settings of the workout. Hold the handrails and begin walking.

Each workout is divided into segments. One speed setting and one incline setting are programmed for each segment. Note: The same speed and/or incline setting may be programmed for consecutive segments.

During the workout, the profile will show your progress. The flashing segment of the profile represents the current segment of the workout. The height of the flashing segment indicates the speed setting for the current segment. At the end of each

segment, the next segment of the profile will begin to flash and the speed and incline settings will appear at the top of the display for a few moments to alert you.

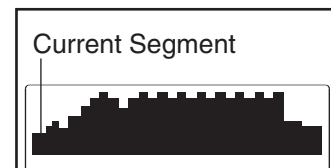

The workout will continue in this way until the last segment of the profile flashes in the display and the last segment ends. The walking belt will then slow to a stop.

If the speed or incline setting is too high or too low at any time during the workout, you can manually override the setting by pressing the Speed or Incline buttons; **however, when the next segment of the workout begins, the treadmill will automatically adjust to the speed and incline settings for the next segment.** Note: If you use an Interval workout, the incline will not adjust automatically.

To stop or restart the workout at any time, press the Start/Stop button.

4. Select a display mode and monitor your progress with the display.

The console offers three display modes. The display mode that you select will determine which workout information is shown. Press the Display button repeatedly to select the desired display mode.

The display can show the speed of the walking belt, the incline of the treadmill, a profile of the workout, the time remaining in the workout, the distance you have walked or run, the approximate number of calories you have burned, your exercise intensity in mets, the approximate number of calories burned per hour, your pace, and your power output in watts.

5. Measure your heart rate if desired.

See step 6 on page 17.

6. Turn on the fan if desired.

See step 7 on page 17.

7. When you are finished exercising, remove the key from the console.

See step 8 on page 17.

HOW TO USE A WALK/RUN WORKOUT OR A MANUAL CONTROL WORKOUT

1. Insert the key into the console.

See HOW TO TURN ON THE POWER on page 16.

2. Select one of the workouts.

To select a walk/run workout, press the Walk/Run Workouts button repeatedly until the 5K Walk, the 10K Walk, or the Cross Country workout appears in the display.

To select a manual control workout, press the Manual Control button repeatedly until the Manual Time, the Manual Distance, or the Manual Calories workout appears in the display.



The display will show the name, the maximum incline setting, the maximum speed setting, and the duration of the workout.

Press the Enter button to select the desired workout. Select your age and then your weight using the Increase and Decrease buttons next to the Enter button. **Press the Enter button after each selection.** Note: To use the cross country workouts, you must also enter your distance goal. To use a manual control workout, enter your time, distance, or calorie goal.

3. Press the Start/Stop button to start the workout.

A moment after you press the Start/Stop button, the treadmill will begin moving. Hold the handrails and begin walking.

During the workout, the profile will show the incline of the walking belt. As you exercise, change the speed and incline of the walking belt as desired by pressing the Speed and Incline increase and decrease buttons.

The workout will continue until you reach your time, distance, or calorie goal. The walking belt will then slow to a stop.

To stop or restart the workout at any time, press the Start/Stop button.

4. Select a display mode and monitor your progress with the display.

See step 4 on page 18.

5. Measure your heart rate if desired.

See step 6 on page 17.

6. Turn on the fan if desired.

See step 7 on page 17.

7. When you are finished exercising, remove the key from the console.

See step 8 on page 17.

HOW TO USE A FITNESS TEST WORKOUT

The fitness test workouts measure your relative fitness level. For the most accurate results, use a fitness test workout when you are not feeling tired, when you have not eaten for at least two hours, and when you have not exercised for at least 24 hours.

The treadmill features three fitness workouts. The Ebbeling Fitness Test measures VO₂ max, or aerobic capacity, and lasts 9 minutes. The Gerkin Fitness Test also measures VO₂ max. The Gerkin Fitness Test begins with a three-minute warm-up period and ends after either 14 minutes or when you reach a certain heart rate. The FreeMotion Fitness Test measures your fitness level on a scale of 1 to 10. The FreeMotion Fitness Test ends after either 28 minutes or when you reach a certain heart rate.

1. Put on a Polar®-compatible chest pulse sensor (not included).

To use a fitness test, you must wear a Polar-compatible chest pulse sensor or use the handgrip pulse sensor. Note: For best results, you should wear a chest pulse sensor. No chest pulse sensor is included.

2. Insert the key into the console.

See HOW TO TURN ON THE POWER on page 16.

3. Select a fitness test workout.

To select a fitness test workout, press the Fitness Tests button repeatedly until the name of the desired fitness test appears in the display.

Press the Enter button to select the desired workout. Select your age and then your weight using the Increase and Decrease buttons next to the Enter button. **Press the Enter button after each selection.** Note: To use the Ebbeling Fitness Test, you must also enter your gender.

4. Press the Start/Stop button to start the workout.

A moment after you press the Start/Stop button, the treadmill will automatically adjust to the first speed and incline settings of the fitness test. Begin walking on the treadmill. Note: For the most accurate results, do not hold the handrails during a fitness test workout.

During the workout, the speed and incline of the treadmill will periodically change. The speed setting or the incline setting will appear in the display to alert you before each change. **IMPORTANT: The Speed and Incline buttons will not function during a fitness test workout.**

Note: If you press the Start/Stop button during the fitness test, the fitness test will end.

When the workout ends, the walking belt will slow to a stop and your fitness level or VO₂ max will appear in the display.

If your pulse is not detected during the workout, the words CHECK HEART RATE MONITOR will appear in the display and the speed of the treadmill may automatically decrease. If your pulse is still not detected, the fitness test will be aborted.

5. Select a display mode and monitor your progress with the display.

See step 4 on page 18. Note: The fitness tests will display your fitness level instead of your exercise intensity in mets.

6. Turn on the fan if desired.

See step 7 on page 17.

7. When you are finished exercising, remove the key from the console.

See step 8 on page 17.

HOW TO USE A HEART RATE WORKOUT

⚠ CAUTION: If you have heart problems, or if you are over 60 years of age and have been inactive, do not use the pulse workouts. If you are taking medication regularly, consult your physician to find out whether the medication will affect your exercise heart rate.

1. Put on a Polar®-compatible chest pulse sensor (not included).

To use a heart rate program, you must wear a Polar-compatible chest pulse sensor or use the handgrip pulse sensor. Note: For best results, you should wear a chest pulse sensor. No chest pulse sensor is included.

2. Insert the key into the console.

See HOW TO TURN ON THE POWER on page 16.

3. Select one of the heart rate workouts.

To select a heart rate workout, press the Heart Rate Control button repeatedly until the desired workout appears in the display. Press the Enter button to select the desired workout.

Select your age and then your weight using the Increase and Decrease buttons next to the Enter button. **Press the Enter button after each selection.** Note: To use the constant heart rate and variable heart rate workouts, you must also enter your target maximum heart rate. If the target maximum heart rate setting is changed, the intensity level of the entire workout will change. Note: To calculate your target maximum heart rate see EXERCISE INTENSITY on page 31.

4. Press the Start/Stop button to start the workout.

A moment after the Start/Stop button is pressed, the walking belt will begin to move and the tread-

mill will automatically adjust to the first speed and incline settings of the workout. Hold the handrails and begin walking.

The heart rate workouts are divided into several one-minute segments. One target heart rate setting is programmed for each segment. The same target heart rate setting may be programmed for consecutive segments. For a shorter workout, simply stop the workout before it ends.

During all heart rate workouts, the console will regularly compare your heart rate to the target heart rate setting. If your heart rate is too far below or above the target heart rate setting for the current segment, the speed of the walking belt will automatically increase or decrease to bring your heart rate closer to the target heart rate setting.

If the speed or incline setting is too high or too low at any time during the workout, you can adjust the setting with the Speed or Incline buttons. However, each time the console compares your heart rate to the target heart rate setting, the speed of the treadmill may automatically change to bring your heart rate closer to the target heart rate setting.

To stop or restart the workout at any time, press the Start/Stop button.

5. Select a display mode and monitor your progress with the display.

See step 4 on page 18.

6. Turn on the fan if desired.

See step 7 on page 17.

7. When you are finished exercising, remove the key from the console.

See step 8 on page 17.

HOW TO USE A CUSTOM WORKOUT

1. Insert the key into the console.

See HOW TO TURN ON THE POWER on page 16.

2. Select one of the custom workouts.

To select a custom workout, press the Custom Workouts button repeatedly until the desired workout appears in the display.

The display will show the name, the maximum incline setting, the maximum speed setting, and the duration of the workout. **Note: To create a custom workout, see step 3 on page 24.**

Press the Enter button to select the desired workout. Select your age and then your weight using the Increase and Decrease buttons next to the Enter button.

3. Press the Start/Stop button to start the workout.

A moment after you press the Start/Stop button, the treadmill will automatically adjust to the first speed and incline settings that you programmed previously. Hold the handrails and begin walking.

Each custom workout is divided into one-minute segments. One speed setting and one incline setting are programmed for each segment.

During the workout, the profile will show your progress. The flashing segment of the profile represents the current segment of the workout. The height of the flashing segment indicates the incline setting for the current

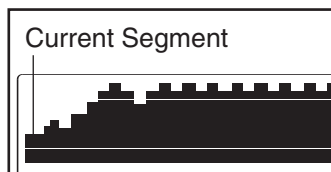

segment. At the end of each segment, a series of tones will sound, the next segment of the profile will begin to flash, and the speed or incline setting for the next segment will appear in the display to alert you.

The workout will continue in this way until the last segment of the profile flashes in the display and the last segment ends. The walking belt will then slow to a stop.

If the speed or incline setting is too high or too low at any time during the workout, you can manually override the setting by pressing the speed or incline buttons; **however, when the next segment of the workout begins, the treadmill will automatically adjust to the speed and incline settings for the next segment.**

To stop or restart the workout at any time, press the Start/Stop button. The speed of the walking belt will gradually increase to the speed setting of the current segment.

4. Select a display mode and monitor your progress with the display.

See step 4 on page 18.

5. Measure your heart rate if desired.

See step 6 on page 17.

6. Turn on the fan if desired.

See step 7 on page 17.

7. When you are finished exercising, remove the key from the console.

See step 8 on page 17.

HOW TO USE AN iFIT WORKOUT

1. Insert the key into the console.

See HOW TO TURN ON THE POWER on page 16.

2. Insert an iFIT card and select a workout.

To use an iFIT workout, insert an iFIT card into the iFIT slot on the back of the console; make sure that the iFIT card is oriented so the missing corner is facing downward and is inserted into the iFIT slot.

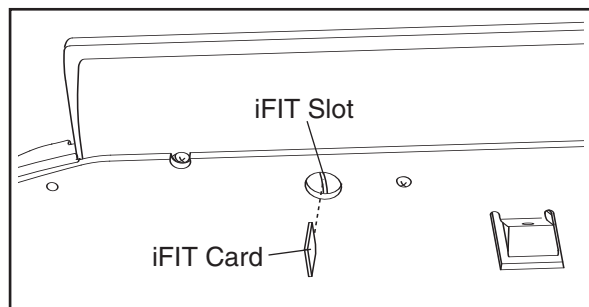

Next, select an iFIT workout by pressing the Increase and Decrease buttons next to the Enter button. When an iFIT workout is selected, the display will show the name of the workout, the maximum incline setting and the maximum speed setting of the workout, and the workout time.

Each iFIT workout is divided into one-minute segments. One speed setting and one incline setting are programmed for each segment. Note: The same speed and/or incline setting may be programmed for consecutive segments.

3. Press the Start/Stop button to start the workout.

A moment after you press the button, the treadmill will automatically adjust to the first speed and incline settings of the workout. Hold the handrails and begin walking.

At the end of each one-minute segment, the speed and incline settings for the next segment will appear in the display and a series of tones will sound to alert you. If a different speed and/or incline setting is programmed for the next segment, three tones will sound.

If the speed or incline setting for the current segment is too high or too low, you can manually override the setting by pressing the Speed or Incline buttons; **however, when the next segment begins, the treadmill will automatically adjust to the speed and incline settings for the next segment.**

To stop the workout at any time, press the Stop button. To restart the workout, press the Start button or the Speed increase button. The walking belt will begin to move. When the next segment of the workout begins, the treadmill will automatically adjust to the speed and incline settings for the next segment.

4. Select a display mode and monitor your progress with the display.

See step 4 on page 18.

5. Measure your heart rate if desired.

See step 6 on page 17.

6. Turn on the fan if desired.

See step 7 on page 17.

7. When you are finished exercising, remove the key from the console.

See step 8 on page 17.

CAUTION: Always remove iFIT cards from the iFIT slot when you are not using them.

HOW TO USE THE MAINTENANCE MODE

The console has a maintenance mode that keeps track of the total number of hours that the treadmill has been operated and the total distance that the walking belt has moved. The maintenance mode also allows you to adjust the maximum workout time, the pause timeout, and the sleep timeout. You can also select the desired language and disable or enable the safety key.

1. Select the maintenance mode.

To select the maintenance mode, hold down the Clear button and the Enter button for three seconds.

Press the Display button to move between screens. Press the Back button to return to a previous screen. To change the settings, press the Increase and Decrease buttons next to the Enter button.

2. Set user preferences.

When you select the maintenance mode, the display will show the total number of hours and the total number of miles (or kilometers) that the walking belt has moved. Press the Display button to move to the next screen.

If desired, set the maximum workout time for the Random, Interval, Terrain, Manual Time, and Heart Rate workouts using the Increase and Decrease buttons.

Next, press the Display button to move the cursor to the pause timeout. Set the pause timeout, if desired. The pause timeout begins when the walking belt stops. When the pause timeout ends, the display will return to the main screen and your distance and calories count will be reset.

Press the Display button to move the cursor to the sleep timeout. Set the sleep timeout, if desired. The sleep timeout begins when the display returns to the main screen. When the sleep timeout ends, the incline will lower to the lowest setting and the screen saver will appear.

Next, press the Display button to move to the next screen. Set the default input, if desired. To use the optional TV, select the TV mode. To use a VCR or DVD player with the optional TV, select the RCA mode. To use a personal media player, select the MP3 mode.

Press the Display button to move to the next screen. You may be able to select one of five languages for the displays. If desired, select a language for the displays.

3. Create custom workouts.

If desired, create a custom workout. Press the Display button until the desired custom workout is shown. Then press the Enter button. Program a speed setting and an incline setting for the first one-minute segment by pressing the Speed and Incline buttons. Press the Enter button to move to the next segment and continuing programming segments for 30 segments. Press the Enter button after you have programmed the last segment. Then press the Display button until you exit the information mode.

4. Enable or disable the safety key.

If desired, disable or enable the safety key. When the safety key is enabled, the key must be inserted into the console for the treadmill to turn on. To disable the safety key, push the Increase or Decrease button. Note: To disable or enable the safety key, you must remove the key from the console before you enter the maintenance mode. For best results, operate the treadmill with the safety key enabled.

To exit the maintenance mode at any time, remove the key from the console.

HOW TO USE THE STEREO SOUND SYSTEM

To play music or audio books through the console's stereo speakers, you must connect your MP3 player, CD player, or other personal audio player to the console. Locate the audio wire and plug it into the MP3 jack near the Start/Stop button. Then, plug the other end into a jack on your MP3 player, CD player, or other personal audio player. **Make sure that the audio wire is fully plugged in.**

Next, press the Play button on your MP3 player, CD player, or other personal audio player. Then, adjust the volume on your personal audio player.

If you are using a personal CD player and the CD skips, set the CD player on the floor or another flat surface instead of on the console.

PREVENTIVE MAINTENANCE

Regular maintenance is necessary for optimal performance and long life of the treadmill. Please read and follow all instructions below. If the treadmill is not maintained as described, components may wear excessively, the treadmill may be damaged, and the warranty will be voided. If you have questions about maintenance, please see the front cover of this manual. **CAUTION: Make sure to remove the key and unplug the power cord before performing any maintenance procedures.**

WEEKLY MAINTENANCE

1. **Unplug the power cord.** Inspect and properly tighten all external parts of the treadmill.
2. Apply a mild multi-purpose cleaner to a 100% cotton cloth and remove any dust and grime from the handrails, uprights, foot rails, frame, and motor hood. In addition, wipe the walking platform along the sides of the walking belt. **Do not wipe under the walking belt.** Apply a small amount of mild multi-purpose cleaner to a 100% cotton cloth and wipe the console and the screens. **Do not spray cleaner directly onto the treadmill or use ammonia or acid-based cleaners.**
3. Make sure that the walking belt is centered and properly tightened. If it is centered and runs smoothly, do not make any adjustments. If the walking belt needs to be adjusted, see pages 29 and 30.

MONTHLY MAINTENANCE

1. **Unplug the power cord.** Remove the two 1/4" x 3/4" Bolts (23) and the two 1/2" x 1" Bolts (37) attaching the Motor Hood (82), and lift off the Motor Hood.

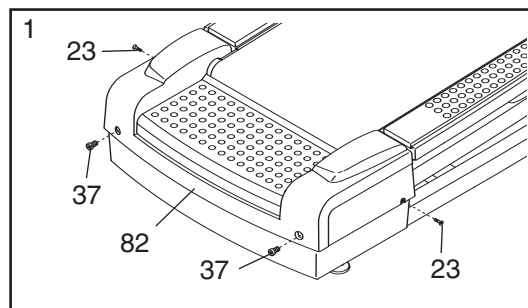

2. Using a hand-held vacuum, clean the area under the Motor Hood (not shown). **Be careful to avoid touching any components.** Check the drive belt for wear and cracks. If the drive belt needs to be replaced, please see the front cover of this manual.

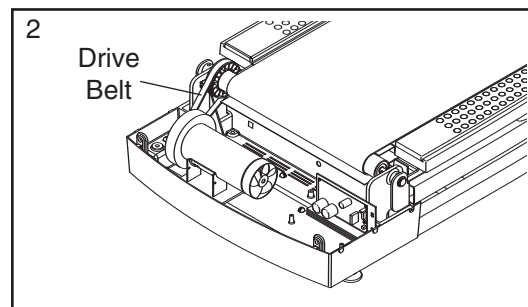

3. Plug in the power cord and insert the key into the console. Press the Start/Stop button. **IMPORTANT: Be careful to avoid injury; keep your hands away from moving parts and make sure that your clothes cannot become caught in moving parts.** While the walking belt is moving, check the treadmill for unusual noises or odors. If any of these problems exists, please see the front cover of this manual. **Remove the key and unplug the power cord.** Reattach the Motor Hood (82) with the two 1/4" x 3/4" Bolts (23) and the two 1/2" x 1" Bolts (37).

REPLACING THE WALKING BELT

When the walking belt becomes worn, it should be replaced. The walking belt will need to be replaced after every 10,000 to 15,000 miles (16,000 to 24,000 kilometers). See the Service Manual for replacement instructions. Please see the front cover of this manual to order a new walking belt.

REPLACING THE WALKING PLATFORM

When both sides of the walking platform become worn, the walking platform should be replaced. The walking platform will need to be replaced after every 20,000 to 30,000 miles (32,000 to 48,000 kilometers). Please see the front cover of this manual to order a new walking platform. Follow the instructions below to replace the walking platform.

TURNING THE WALKING PLATFORM

Both sides of the walking platform are designed to be used as walking surfaces. Inspect the walking platform periodically for wear. If there is any wood showing through the phenolic coating, or if the surface is damaged, the walking platform should be turned over. The walking platform will need to be turned over and the walking belt replaced (see above) after every 10,000 to 15,000 miles (16,000 to 24,000 kilometers). Follow the instructions below to turn over the walking platform.

1. **Remove the key and unplug the power cord.** Remove the four 5/16" x 1" Bolts (28) and the Front Roller Cover (68). Remove the two 5/16" x 4 3/8" Bolts (29) and 5/16" Star Washers (54).

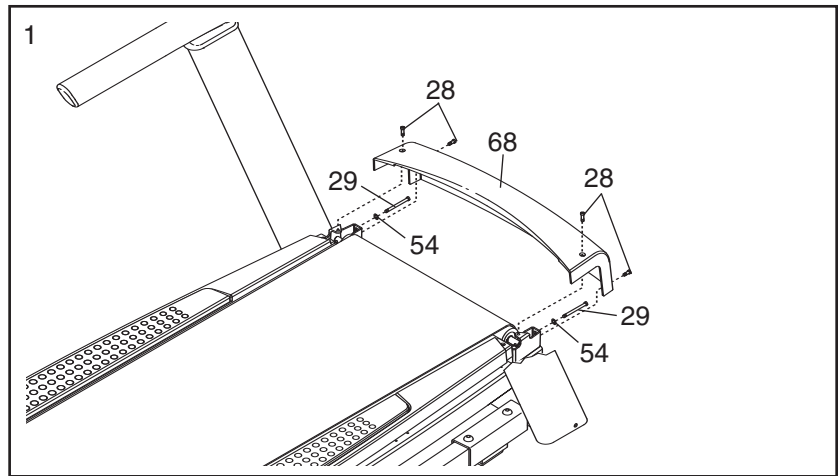

2. Remove the Left and Right Foot Rail Covers (58, 70). Remove the #12 x 1" Screws (20) and the Left and Right Foot Rails (59, 71).

Remove the 1/4" x 1 1/2" Bolts (111), the 3/8" x 1 3/4" Bolts (112), and the 3/8" Platform Nuts (113).

Remove the #10 x 1 1/2" Screws (21) and the Roller Guards (74).

Lift the Front Roller (67) and slide it out of the Walking Belt (64).

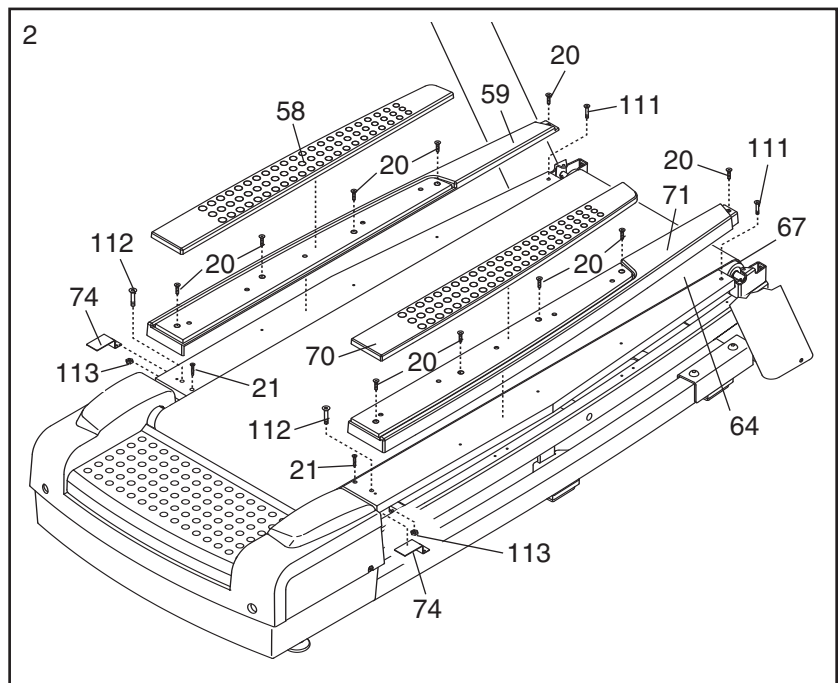

3. **Note: Be very careful to avoid chipping or damaging the phenolic coating on the Walking Platform (63).** Lift the Walking Platform and the Walking Belt (64) to the position shown by the dotted lines. Slide the Walking Platform out of the Walking Belt, turn it, and then slide it back into the Walking Belt.

Lay down the Walking Platform (63) and the Walking Belt (64). Slide the Front Roller (67) back into the Walking Belt.

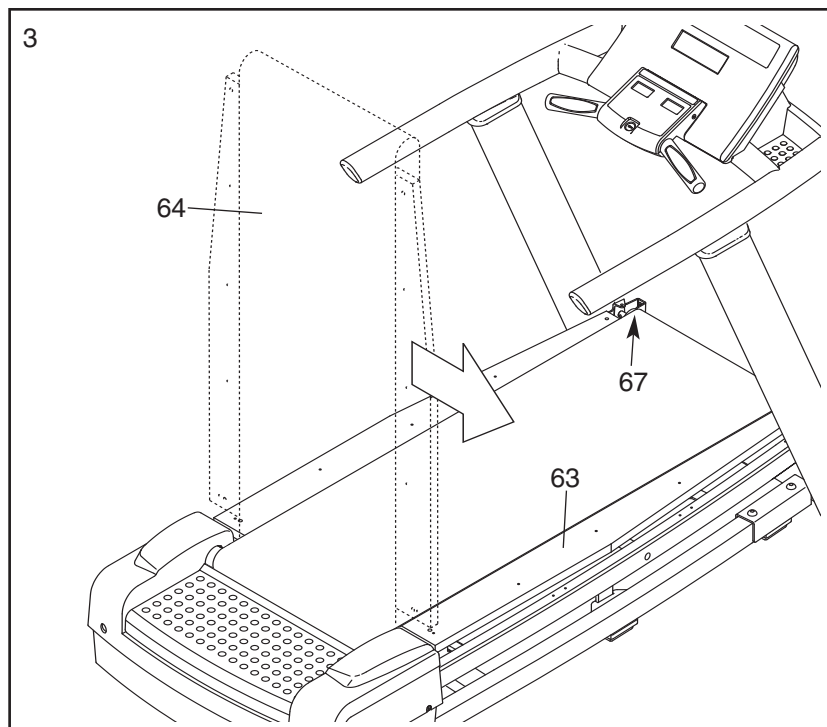

4. **See step 1.** Reattach the 5/16" x 4 3/8" Bolts (29) and the 5/16" Star Washers (54). **Make sure that the walking belt is centered. Do not fully tighten the Bolts; the Bolts should only be tight enough to remove the slack from the walking belt.**
5. **See step 2.** Reattach the Roller Guards (74), the Walking Platform (63), the Foot Rails (59, 71), and the Foot Rail Covers (58, 70).
6. **See step 1.** Reattach the Front Roller Cover (68). **Make sure that the Walking Belt (64) is centered on the Front Roller (67).** Then, partially tighten the 5/16" x 4 3/8" Bolts (29) until the Walking Belt cannot be pushed to the left or right on the Front Roller. **Make sure to turn both Bolts the same number of times.**

7. The tension of the Walking Belt (64) now needs to be adjusted. Turn each 5/16" x 4 3/8" Bolt (29) clockwise four times. Center the Walking Belt if necessary (see page 30). Then, step onto the Footrails (59, 71), insert the key into the console, and press the Start/Stop button. Hold the handrails and gently press one foot against the moving Walking Belt. If the Walking Belt stops moving, remove the key from the console and turn each Bolt one more time. Continue to test the tension of the Walking Belt until the Walking Belt no longer slips. Make sure to keep the Walking Belt centered. **If the Front Roller (67) stops moving, do not further tighten the Bolts; please see the front cover of this manual.**

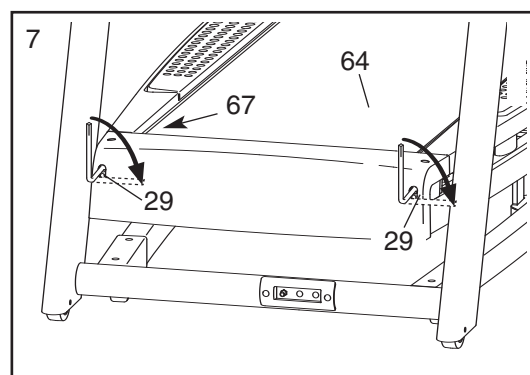

IMPORTANT: The ideal tension is just enough to prevent the walking belt from slipping. This will maximize the life of the walking belt, the roller, and the drive system. Overtightening the walking belt can lead to premature walking belt failure and excess wear to the bearings and drive components.

SIX-MONTH PREVENTIVE MAINTENANCE RECORD

Photocopy this form and use it to record the preventive maintenance performed on the treadmill. Each copy of the form can be used for six months (26 weeks). When maintenance is performed, write the date in the appropriate spaces. **Make sure to perform each maintenance procedure as described on pages 25 to 27. If the procedures are not performed as described, components may wear excessively, the treadmill may be damaged, and the warranty will be voided.**

	Weekly Maintenance			Monthly Maintenance		
	Inspect and tighten all external parts of the treadmill.	Clean the treadmill.	Check the walking belt for proper tension and alignment.	Remove the motor hood and vacuum the motor compartment.	Check the motor belt for cracks and other wear.	Check the motor for arcing; check for noises or odors.
Week 1	/ /	/ /	/ /			
Week 2	/ /	/ /	/ /			
Week 3	/ /	/ /	/ /			
Week 4	/ /	/ /	/ /	/ /	/ /	/ /
Week 5	/ /	/ /	/ /			
Week 6	/ /	/ /	/ /			
Week 7	/ /	/ /	/ /			
Week 8	/ /	/ /	/ /	/ /	/ /	/ /
Week 9	/ /	/ /	/ /			
Week 10	/ /	/ /	/ /			
Week 11	/ /	/ /	/ /			
Week 12	/ /	/ /	/ /			
Week 13	/ /	/ /	/ /	/ /	/ /	/ /
Week 14	/ /	/ /	/ /			
Week 15	/ /	/ /	/ /			
Week 16	/ /	/ /	/ /			
Week 17	/ /	/ /	/ /	/ /	/ /	/ /
Week 18	/ /	/ /	/ /			
Week 19	/ /	/ /	/ /			
Week 20	/ /	/ /	/ /			
Week 21	/ /	/ /	/ /	/ /	/ /	/ /
Week 22	/ /	/ /	/ /			
Week 23	/ /	/ /	/ /			
Week 24	/ /	/ /	/ /			
Week 25	/ /	/ /	/ /			
Week 26	/ /	/ /	/ /	/ /	/ /	/ /

Walking Platform Turned/Replaced	/ /	/ /	Walking Belt Replaced	/ /
----------------------------------	-----	-----	-----------------------	-----

TROUBLESHOOTING

Most treadmill problems can be solved by following the steps below. Find the symptom that applies, and follow the steps listed. If further assistance is needed, please see the front cover of this manual.

PROBLEM: The power does not turn on

SOLUTION: a. Make sure that the power cord is plugged into a surge suppressor, and that the surge suppressor is plugged into a properly grounded outlet (see page 13). Use only a single-outlet surge suppressor that meets all of the specifications described on page 13. Important: The treadmill is not compatible with GFCI-equipped outlets.

b. After the power cord has been plugged in, make sure that the key is inserted into the console.

c. Check the reset/off circuit breaker located on the treadmill frame near the power cord. If the switch protrudes as shown, the circuit breaker has tripped. To reset the circuit breaker, wait for five minutes and then press the switch back in.

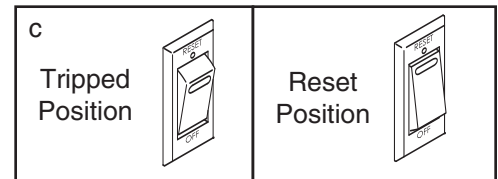

PROBLEM: The power turns off during use

SOLUTION: a. Check the reset/off circuit breaker (see the drawing above). If the circuit breaker has tripped, wait for five minutes and then press the switch back in.

b. Make sure that the power cord is plugged in. If the power cord is plugged in, unplug it, wait for five minutes, and then plug it back in.

c. Remove the key from the console. Reinsert the key into the console.

d. If the power still turns off during use, see the front cover of this manual.

PROBLEM: The walking belt slows when walked on

SOLUTION: a. Use only a single-outlet surge suppressor that meets all of the specifications described on page 13.

b. If the walking belt is overtightened, performance may decrease and the walking belt may be damaged. If the walking belt is properly tightened, you should be able to lift each edge of the walking belt 2 to 3 in. (5 to 7.6 cm) off the walking platform. **If adjustments need to be made, first remove the key and unplug the power cord.** Using the included hex key, turn both 5/16" x 4 3/8" Bolts (29) counterclockwise 1/4 of a turn. Then, plug in the power cord, insert the key, and use the treadmill for a few minutes. Be careful to keep the walking belt centered. Repeat until the walking belt is properly tightened. Note: To tighten the walking belt, see step c on page 30.

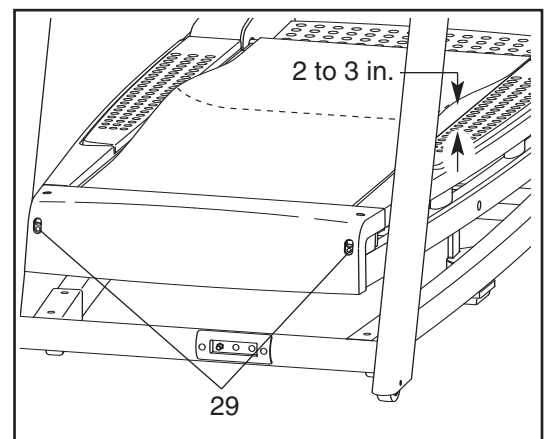

c. If the walking belt still slows when walked on, see the front cover of this manual.

PROBLEM: The walking belt is off-center or slips when walked on

SOLUTION: a. If the walking belt has shifted to the right:
Remove the key and unplug the power cord.
Using the included hex key, turn the 5/16" x 4 3/8" bolts in the directions shown, 1/4 of a turn each. Be careful not to overtighten the walking belt. Then, plug in the power cord, insert the key, and use the treadmill for a few minutes. Repeat until the walking belt is centered.

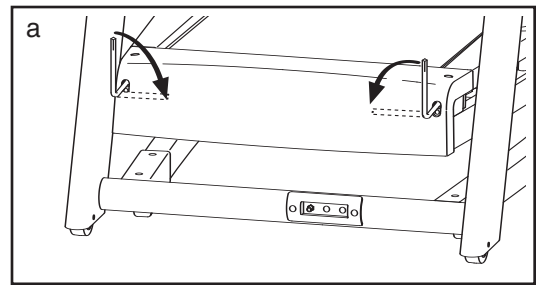

b. If the walking belt has shifted to the left:
Remove the key and unplug the power cord.
Using the included hex key, turn the 5/16" x 4 3/8" bolts in the directions shown, 1/4 of a turn each. Be careful not to overtighten the walking belt. Then, plug in the power cord, insert the key, and use the treadmill for a few minutes. Repeat until the walking belt is centered.

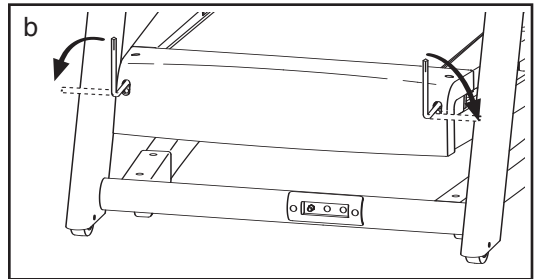

c. If the walking belt slips when walked on:
Remove the key and unplug the power cord.
Using the included hex key, turn both 5/16" x 4 3/8" bolts clockwise 1/4 of a turn. When the walking belt is properly tightened, you should be able to lift each edge of the walking belt 1 to 2 in. (2.5 to 5 cm) off the walking platform. The center of the walking belt should just touch the walking platform. Make sure to keep the walking belt centered. Then, plug in the power cord, insert the key, and run the treadmill for a few minutes. Repeat until the walking belt is properly tightened. Note: As you tighten the roller adjustment bolts, the front roller will move. **If the front roller stops moving, do not further tighten the roller adjustment bolts; please see the front cover of this manual.**

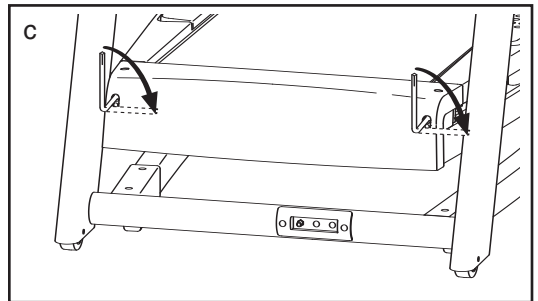

PROBLEM: The incline of the treadmill does not change correctly

SOLUTION: a. The incline system may need to be calibrated. To initiate the calibration routine, turn the power switch off, wait 5 seconds and then turn the power switch back on. During the calibration routine, the treadmill will automatically travel to the highest incline level and then return to the initial level.

b. If the incline system still does not function properly, please see the front cover of this manual.

EXERCISE GUIDELINES

⚠️ WARNING: Before beginning any exercise program, consult your physician. This is especially important for persons over the age of 35 or persons with pre-existing health problems.

The pulse sensor is not a medical device. Various factors may affect the accuracy of heart rate readings. The pulse sensor is intended only as an exercise aid in determining heart rate trends in general.

These guidelines will help you to plan your exercise program. For detailed exercise information, obtain a reputable book or consult your physician. Remember, proper nutrition and adequate rest are essential for successful results.

EXERCISE INTENSITY

Whether your goal is to burn fat or to strengthen your cardiovascular system, exercising at the proper intensity is the key to achieving results. You can use your heart rate as a guide to find the proper intensity level. The chart below shows recommended heart rates for fat burning and aerobic exercise.

165	155	145	140	130	125	115	♥♥
145	138	130	125	118	110	103	♥
125	120	115	110	105	95	90	♥
<hr/>							
20	30	40	50	60	70	80	

To find the proper intensity level, find your age at the bottom of the chart (ages are rounded off to the nearest ten years). The three numbers listed above your age define your “training zone.” The lowest number is the heart rate for fat burning, the middle number is the heart rate for maximum fat burning, and the highest number is the heart rate for aerobic exercise.

Burning Fat—To burn fat effectively, you must exercise at a low intensity level for a sustained period of time. During the first few minutes of exercise, your body uses *carbohydrate calories* for energy. Only after the first few minutes of exercise does your body begin to use stored *fat calories* for energy. If your goal is to burn fat, adjust the intensity of your exercise until your heart rate is near the lowest number in your training zone. For maximum fat burning, exercise with your heart rate near the middle number in your training zone.

Aerobic Exercise—If your goal is to strengthen your cardiovascular system, you must perform aerobic exercise, which is activity that requires large amounts of oxygen for prolonged periods of time. For aerobic exercise, adjust the intensity of your exercise until your heart rate is near the highest number in your training zone.

WORKOUT GUIDELINES

Warming up—Start with 5 to 10 minutes of stretching and light exercise. A warm-up increases your body temperature, heart rate, and circulation in preparation for exercise.

Training Zone Exercise—Exercise for 20 to 30 minutes with your heart rate in your training zone. (During the first few weeks of your exercise program, do not keep your heart rate in your training zone for longer than 20 minutes.) Breathe regularly and deeply as you exercise—never hold your breath.

Cooling down—Finish with 5 to 10 minutes of stretching. Stretching increases the flexibility of your muscles and helps to prevent post-exercise problems.

EXERCISE FREQUENCY

To maintain or improve your condition, complete three workouts each week, with at least one day of rest between workouts. After a few months of regular exercise, you may complete up to five workouts each week, if desired. Remember, the key to success is to make exercise a regular and enjoyable part of your everyday life.

SUGGESTED STRETCHES

The correct form for several basic stretches is shown at the right. Move slowly as you stretch—never bounce.

1. Toe Touch Stretch

Stand with your knees bent slightly and slowly bend forward from your hips. Allow your back and shoulders to relax as you reach down toward your toes as far as possible. Hold for 15 counts, then relax. Repeat 3 times. Stretches: Hamstrings, back of knees and back.

2. Hamstring Stretch

Sit with one leg extended. Bring the sole of the opposite foot toward you and rest it against the inner thigh of your extended leg. Reach toward your toes as far as possible. Hold for 15 counts, then relax. Repeat 3 times for each leg. Stretches: Hamstrings, lower back and groin.

3. Calf/Achilles Stretch

With one leg in front of the other, reach forward and place your hands against a wall. Keep your back leg straight and your back foot flat on the floor. Bend your front leg, lean forward and move your hips toward the wall. Hold for 15 counts, then relax. Repeat 3 times for each leg. To cause further stretching of the achilles tendons, bend your back leg as well. Stretches: Calves, achilles tendons and ankles.

4. Quadriceps Stretch

With one hand against a wall for balance, reach back and grasp one foot with your other hand. Bring your heel as close to your buttocks as possible. Hold for 15 counts, then relax. Repeat 3 times for each leg. Stretches: Quadriceps and hip muscles.

5. Inner Thigh Stretch

Sit with the soles of your feet together and your knees outward. Pull your feet toward your groin area as far as possible. Hold for 15 counts, then relax. Repeat 3 times. Stretches: Quadriceps and hip muscles.

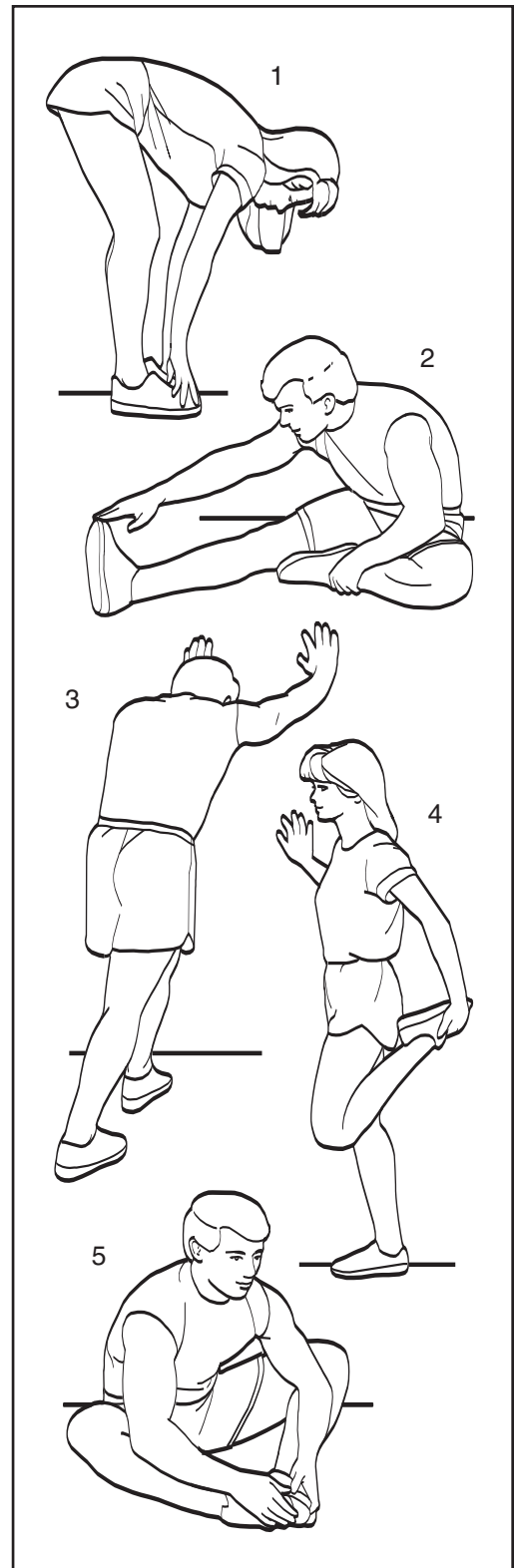

LIMITED WARRANTY

FreeMotion Fitness warrants this product to be free from defects in workmanship and material under normal use and service conditions. The warranty period commences on the invoice date of purchase. Any parts repaired or replaced during this warranty period will be warranted for the remainder of the original warranty period.

WARRANTY PERIODS AND COVERAGE

Residential

This product when used in a residential setting is warranted for the following periods

Frame: Lifetime

Motor: 10 years

Parts: 10 years

Labor: 2 years

Light Commercial

When used in a light commercial setting the warranty is as follows.

Frame: 7 years

Motor: 3 years

Parts: 2 years

Labor: 1 year

Light commercial use is defined as a non-dues-paying institutional setting to include hotels, apartment fitness centers, corporate fitness centers, fire/police stations, and hospital/physical therapy settings. This product is not intended to be used in large, heavy-use settings such as health clubs, colleges/universities, community centers, or military installations. Use of this product in such facilities will void this warranty.

CONDITIONS AND LIMITATIONS

The following will void the warranty on this product:

1. This warranty only applies to the original owner and is non-transferable.
2. Any misuse, abuse, or improper service.
3. Users who weigh more than 350 lbs. (159 kg).
4. Damage caused by moving the product or improper storage, including moving or storing the product on its side.

5. Use or storage of the product outdoors or in high-humidity environments including spa and pool areas.
6. Damage caused by improper wiring or insufficient electrical current.

This warranty shall not apply to the following:

1. Cosmetic items including grips, seats, decals, and labels.
2. Pick-up, delivery, or freight charges involved with a repair.
3. Any problem as a result of improper assembly or delivery.

WHAT TO DO IF SERVICE IS REQUIRED

FreeMotion Fitness warranty service may be obtained by contacting the authorized dealer that you purchased your equipment from. Be sure to retain your original invoice and serial number information. If this product experiences a failure under the warranty terms set forth, FreeMotion Fitness shall provide at their option either repair, replacement or refund of the purchase price. FreeMotion Fitness compensates service providers for warranty trips within their service area. You may be charged additionally for service calls beyond this service area.

FreeMotion Fitness is not responsible or liable for indirect, special or consequential damages arising out of or in connection with the use or performance of the product or damages with respect to any economic loss, loss of property, loss of revenues or profits, loss of enjoyment or use, cost of removal, installation or other consequential damages. Some states do not allow the exclusion or limitation of consequential damages. Accordingly, the above limitation may not apply to you. This warranty gives you specific rights and you may have other rights which vary from state to state.

TO CONTACT FREEMOTION FITNESS

See HOW TO CONTACT CUSTOMER CARE on page 2.

PART LIST—Model No. VMTL83607.1

R0108A

To locate the parts listed below, see the EXPLODED DRAWING near the end of this manual.

Key No.	Qty.	Description	Key No.	Qty.	Description
1	4	1/2" x 3 1/4" Bolt	51	1	Key/Clip
2	4	1/4" x 1" Bolt	52	4	Motor Washer
3	4	3/8" x 2" Bolt	53	4	1/5" Star Washer
4	2	Upper Handrail Endcap	54	2	5/16" Star Washer
5	4	1/2" Jamnut	55	4	3/8" Star Washer
6	4	1/4" "U"-nut	56	1	Front Belly Pan
7	4	1/2" Star Washer	57	2	3/8" Wheel Washer
8	4	1/4" Star Washer	58	1	Left Foot Rail Cover w/Adhesive
9	4	3/8" Star Washer	59	1	Left Foot Rail
10	4	Roller Bracket Screw	60	4	Isolator
11	4	1/4" x 3/4" Bolt	61	2	Belt Guide
12	1	Console	62	2	Front Isolator
13	1	Power Cord Ground Wire	63	1	Walking Platform
14	1	Motor Ground Wire	64	1	Walking Belt
15	8	#8 x 1/2" Screw	65	1	Left Roller Bracket
16	1	Electrical Board Ground Wire	66	1	Right Roller Bracket
17	10	#8 x 3/4" Screw	67	1	Front Roller
18	17	#8 x 1/2" Belly Pan Screw	68	1	Front Roller Cover
19	2	#6 x 1/4" Screw	69	1	Frame
20	10	#12 x 1" Screw	70	1	Right Foot Rail Cover w/Adhesive
21	2	#10 x 1 1/2" Screw	71	1	Right Foot Rail
22	2	#10 x 3/4" Screw	72	2	Frame Bushing
23	2	1/4" x 3/4" Bolt	73	1	Rear Roller
24	2	Motor Bolt	74	2	Roller Guard
25	8	1/4" x 1/2" Bolt	75	1	Base Frame
26	1	1/4" x 2" Bolt	76	4	Base Pad
27	2	1/4" x 3/4" Belt Guide Bolt	77	2	Leveling Foot
28	4	5/16" x 1" Bolt	78	2	Link Arm
29	2	5/16" x 4 3/8" Bolt	79	1	Lift Frame
30	4	3/8" x 1" Motor Bolt	80	1	Incline Motor
31	2	3/8" x 3 1/4" Bolt	81	1	Hood Cover w/Adhesive
32	2	3/8" x 1" Bolt	82	1	Motor Hood
33	4	3/8" x 1 1/2" Bolt	83	1	Controller
34	2	3/8" x 2 1/2" Wheel Bolt	84	1	Magnet
35	1	1/2" x 2" Bolt	85	2	Pulse Grip
36	1	1/2" x 2 1/2" Bolt	86	1	Small Console
37	2	1/2" x 1" Bolt	87	1	Power Cord
38	2	5/8" x 1 1/2" Bolt	88	1	Dust Cover
39	2	Frame Pin	89	1	Belly Pan
40	2	1/4" Speed Sensor Nut	90	1	Power Cord Grommet
41	2	#8 Nut	91	2	Wheel
42	6	3/8" Nut	92	1	Reset/Off Circuit Breaker
43	2	1/2" Nut	93	1	Hex Key
44	1	1/4" Nut	94	1	Drive Motor Isolator
45	1	Drive Belt	95	1	Drive Motor
46	1	80" Wire Harness	96	1	Uprights
47	1	35" Wire Harness	97	1	1/4" Roller Star Washer
48	1	55" Wire Harness	98	1	Right Upright Bracket
49	1	Console Back	99	1	Left Upright Bracket
50	8	1/2" Flat Washer	100	1	Handrail

Key No.	Qty.	Description	Key No.	Qty.	Description
101	6	Accessory Tray Screw	124	1	35" A/V Wire
102	1	Speed Sensor	125	1	45" TV Cable
103	3	1/4" x 1/2" Bracket Bolt	126	1	65" Audio Wire
104	1	Hand Grip Bracket	127	1	65" A/V Wire
105	1	Console Cover	128	1	65" TV Wire
106	2	Caution Decal	129	2	1/4" x 3/4" Bolt
107	1	Cable Tie	130	1	AV Cover
108	1	Cable Tie Screw	131	4	Cable Nut
109	2	3/8" x 2" Bolt	132	2	Runner Bushing
110	2	#10 "U"-nut	133	1	Fan Grill
111	2	1/4" x 1 1/2" Bolt	134	1	Digital Player Tray
112	2	3/8" 1 3/4" Bolt	135	1	Fan
113	2	3/8" Platform Nut	136	4	Fan Screw
114	2	#10 Star Washer	137	1	Audio Wire
115	2	#8 x 3/4" Ground Screw	138	1	TV Console
116	5	#8 Locknut	139	1	TV Console Back
117	7	8" Cable Tie	140	7	TV Console Screw
118	1	Wire Tie	141	1	Left Accessory Tray
119	1	#10 x 3/4" Wire Tie Screw	142	1	Right Accessory Tray
120	4	3/8" Flat Washer	143	2	Lower Handrail Endcap
121	5	#8 x 1/2" Console Cover Screw	*	-	User's Manual
122	2	5/16" x 1 3/4" Bolt			
123	1	35" Audio Wire			

*These parts are not illustrated.
Specifications are subject to change without notice.

EXPLODED DRAWING A—Model No. VMTL83607.1

R0108A

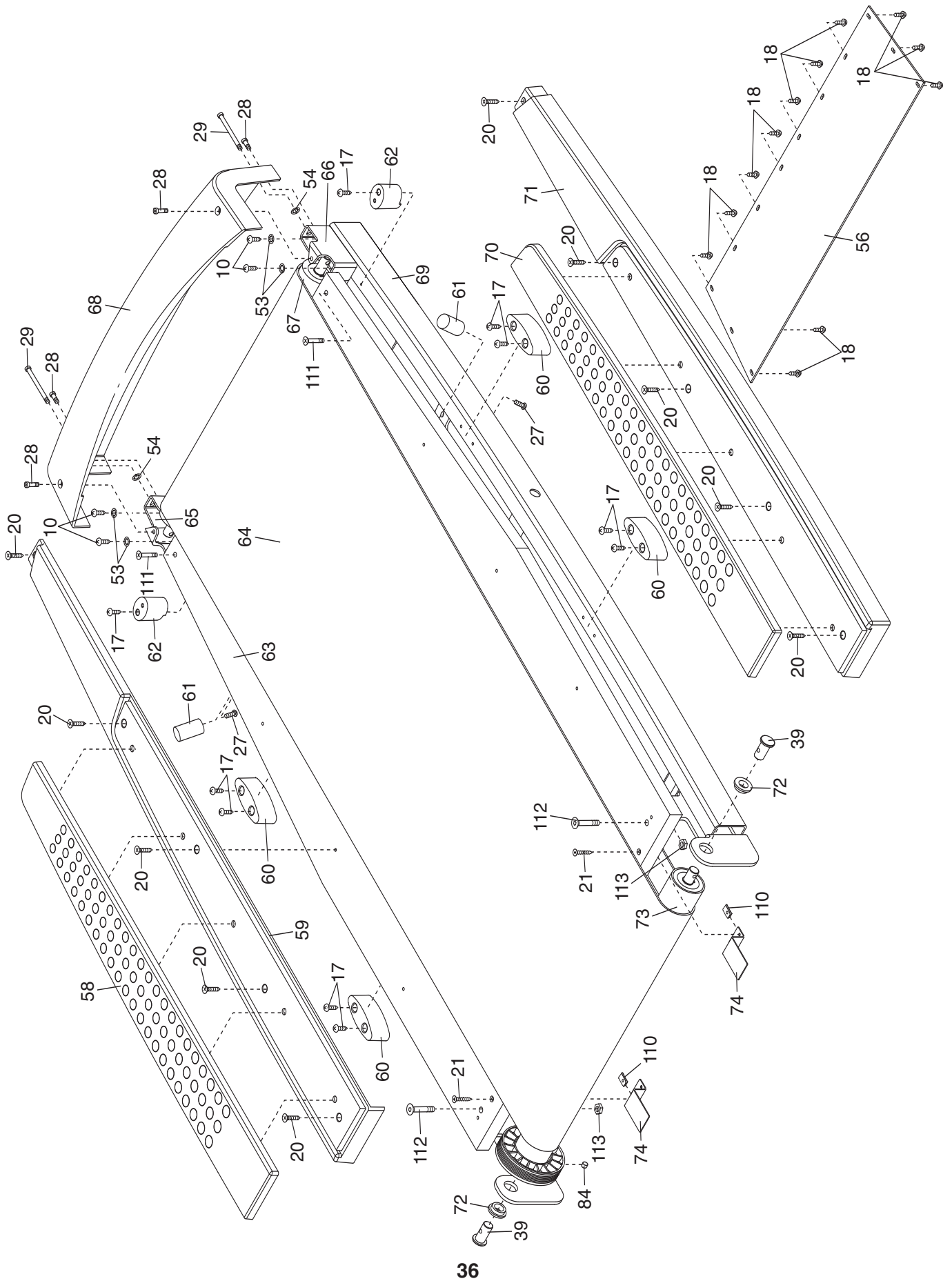

EXPLODED DRAWING B—Model No. VMTL83607.1

R0108A

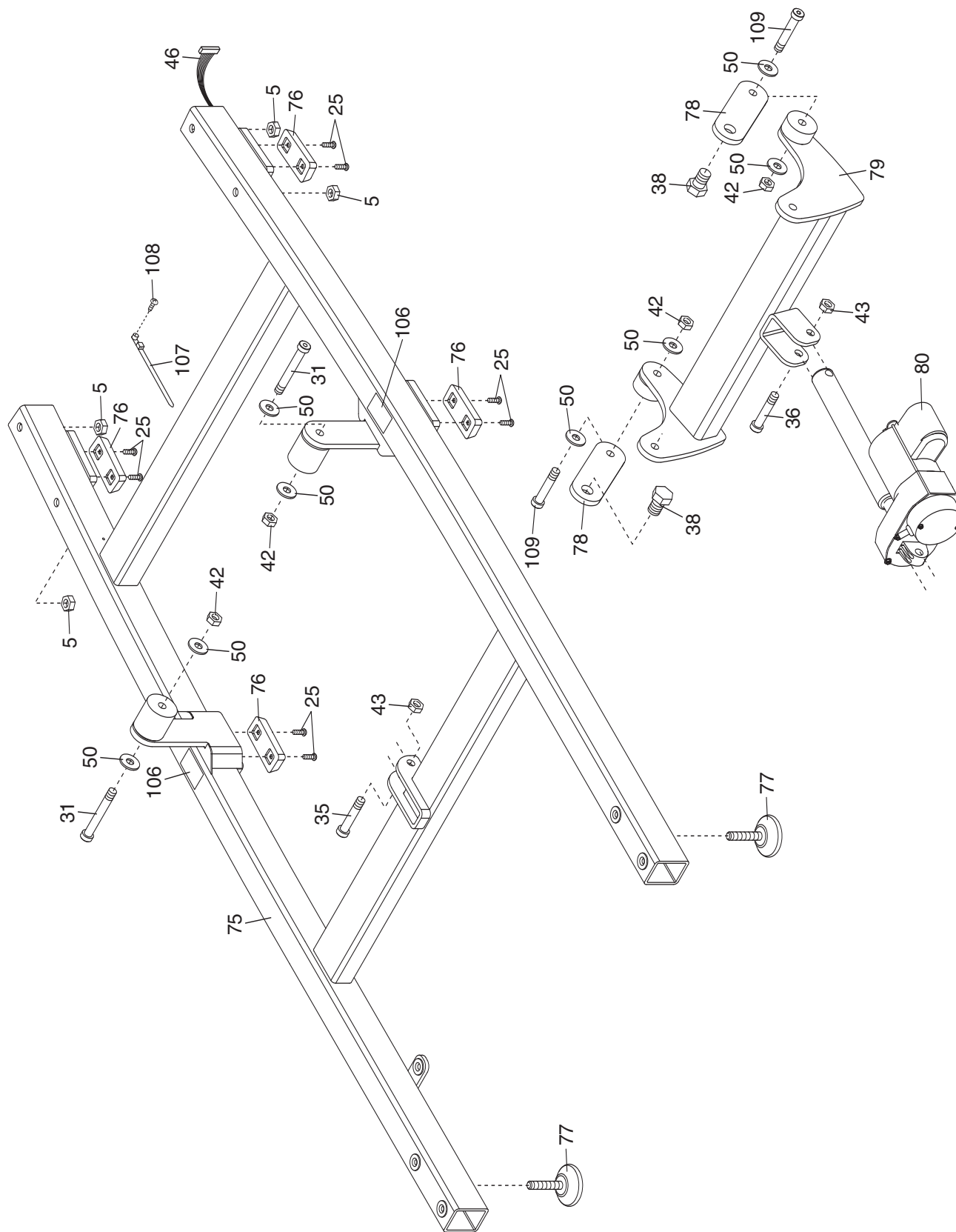

EXPLODED DRAWING C—Model No. VMTL83607.1

R0108A

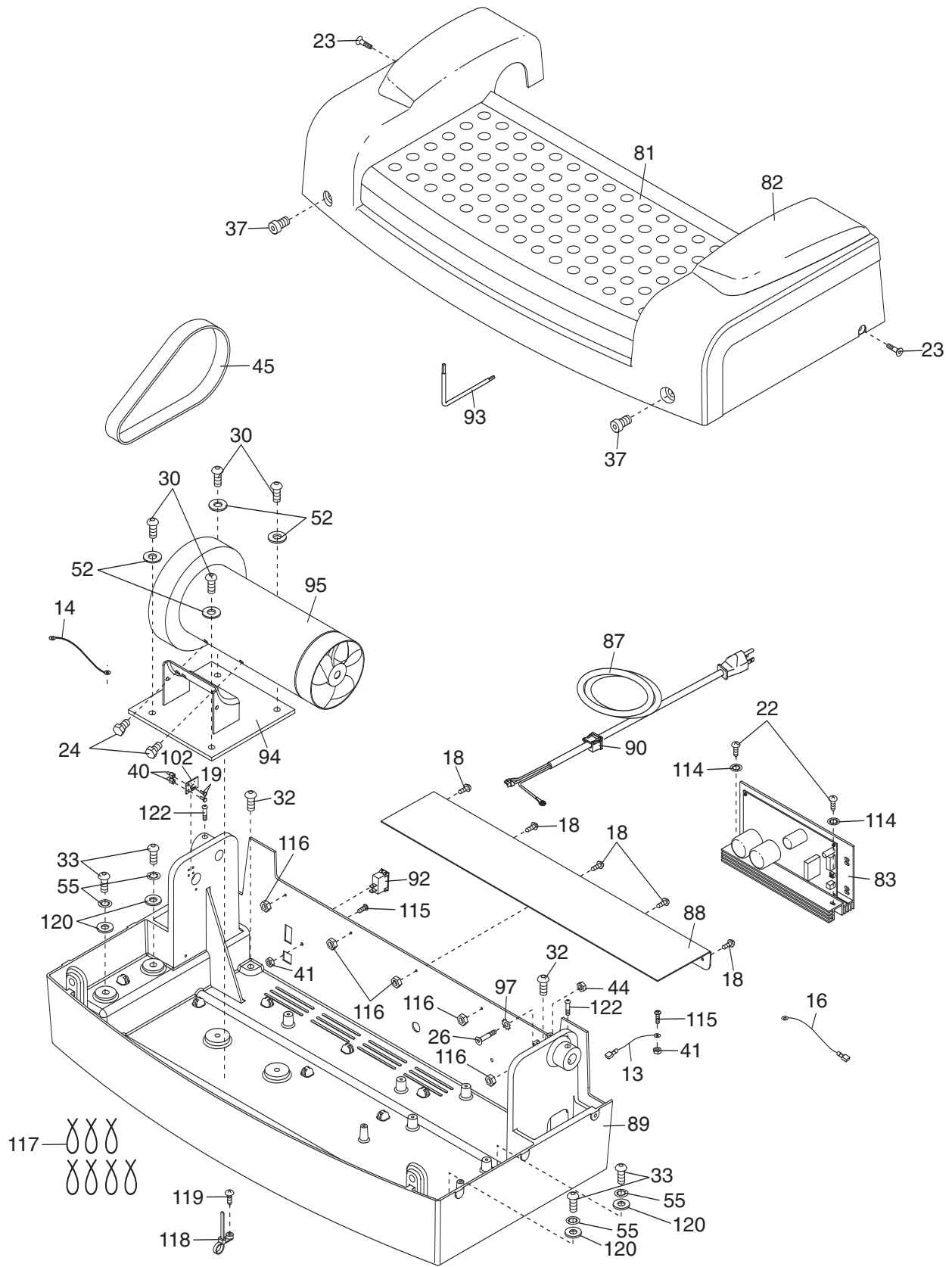

EXPLODED DRAWING D—Model No. VMTL83607.1

R0108A

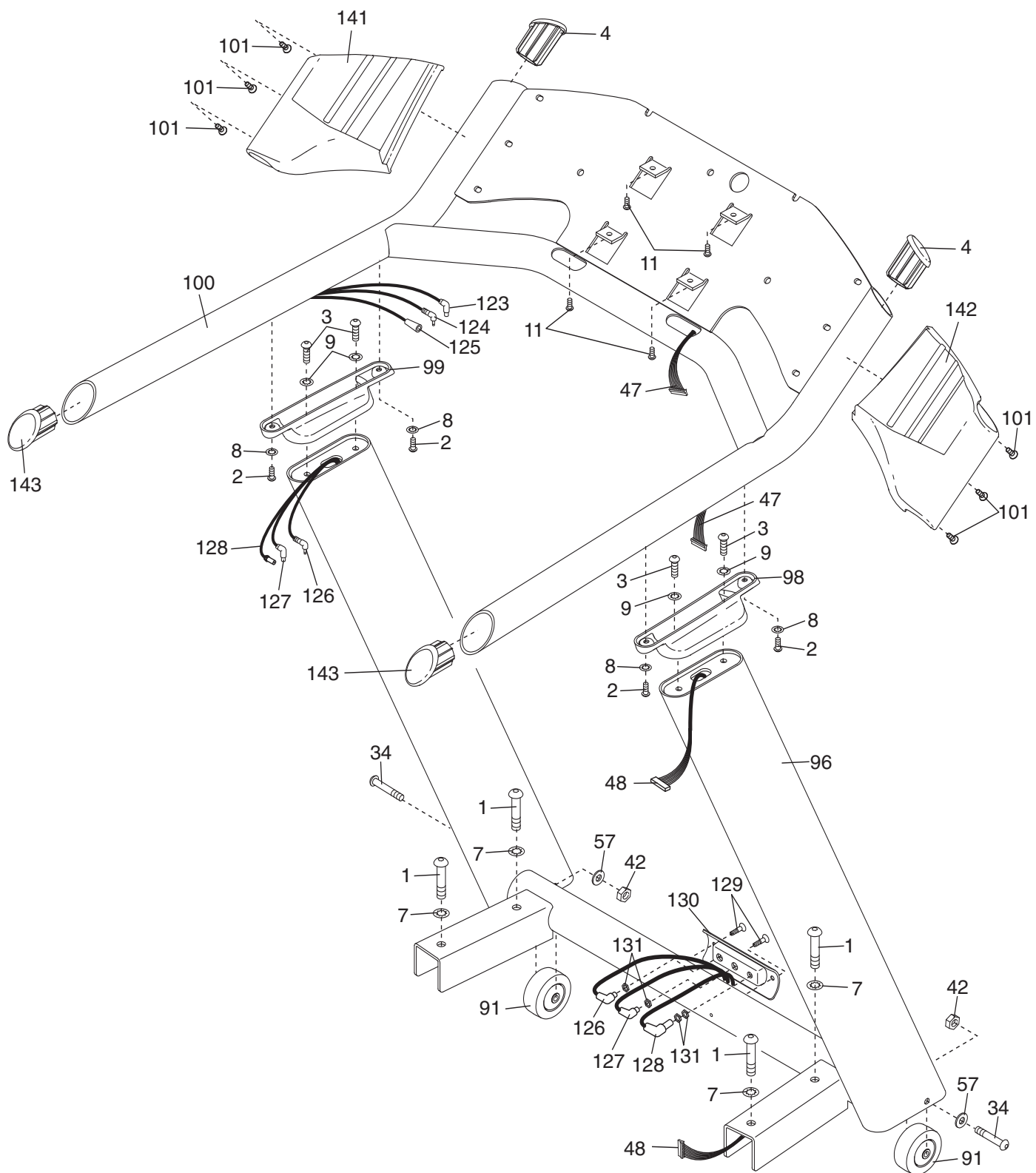

NOTES



FreeMotion Fitness, Inc. • 1096 Elkton Drive, Suite 600 • Colorado Springs, CO 80907