USB-KW2X Hardware

Reference Manual

Document Number: USB-KW2XHWRM

Rev. 0.1

03/2014

How to Reach Us:**Home Page:**
freescale.com**Web Support:**
freescale.com/support

Information in this document is provided solely to enable system and software implementers to use Freescale products. There are no express or implied copyright licenses granted hereunder to design or fabricate any integrated circuits based on the information in this document.

Freescale reserves the right to make changes without further notice to any products herein. Freescale makes no warranty, representation, or guarantee regarding the suitability of its products for any particular purpose, nor does Freescale assume any liability arising out of the application or use of any product or circuit, and specifically disclaims any and all liability, including without limitation consequential or incidental damages. "Typical" parameters that may be provided in Freescale data sheets and/or specifications can and do vary in different applications, and actual performance may vary over time. All operating parameters, including "typicals," must be validated for each customer application by customer's technical experts. Freescale does not convey any license under its patent rights nor the rights of others. Freescale sells products pursuant to standard terms and conditions of sale, which can be found at the following address: freescale.com/SalesTermsandConditions.

Freescale, the Freescale logo, Altivec, CodeWarrior, ColdFire, ColdFire+, Energy Efficient Solutions logo, PowerQUICC, QorIQ, StarCore, Symphony, and VortiQa are trademarks of Freescale Semiconductor, Inc., Reg. U.S. Pat. & Tm. Off. CoreNet, Layerscape, QorIQ Qonverge, QUICC Engine, Tower, and Xtrinsic are trademarks of Freescale Semiconductor, Inc. All other product or service names are the property of their respective owners. ARM and Cortex are registered trademarks of ARM Limited. ARMnnn is the trademark of ARM Limited.

© 2014 Freescale Semiconductor, Inc.



About This Book

Audience	v
Organization	v
Revision History	v

Chapter 1 Safety Information

1.1	FCC Guidelines.	1-1
1.1.1	Labeling	1-1
1.1.2	Operating Conditions	1-1
1.1.3	Exposure Limits	1-1
1.1.4	Antenna Restrictions.	1-1
1.2	Regulatory Approval For Canada (IC RSS 210)	1-2
1.2.1	26 PART 5 – Appendix	1-2
1.3	Electrostatic Discharge Considerations	1-2
1.4	Disposal Instructions.	1-2

Chapter 2 USB-KW24D512 Development Platform Overview and Description

2.1	Introduction.	2-1
2.2	Board Features	2-1
2.2.1	USB-KW24D512 Board.	2-1
2.3	Software and Driver Considerations.	2-3

Chapter 3 USB-KW24D512

3.1	USB-KW24D512 Overview.	3-1
3.1.1	PCB Board Features	3-1
3.1.2	Form Factor.	3-1
3.1.3	Board Level Specifications.	3-2
3.2	Functional Description	3-3
3.2.1	RF Performance and Considerations	3-4
3.2.2	Clocks	3-5
3.2.3	Power Management	3-5
3.2.4	USB-KW24D512 Peripheral Functions	3-6
3.3	Schematic, Board Layout, and Bill of Material	3-7
3.3.1	Bill of Materials	3-9

Chapter 4 PCB Manufacturing Specifications

4.1	Single PCB Construction	4-1
4.2	Panelization.	4-2

4.3	Materials	4-2
4.4	Solder Mask	4-3
4.5	Silk Screen	4-3
4.6	Electrical PCB Testing	4-3
4.7	Packaging	4-3
4.8	Hole Specification/Tool Table	4-3
4.9	File Description	4-4

About This Book

This manual describes Freescale's MKW2xDxxx development platform hardware. The MKW2xDxxx is an IEEE® 802.15.4 compliant evaluation environment based on the Freescale MKW2xDxxx device. The MKW2xDxxx family is Freescale's latest generation ZigBee™ platform, which incorporates a complete low power 2.4 GHz radio frequency transceiver and a Kinetis family low power, mixed-signal ARM® eCortex™-M4 MCU into a single package. This family of products is targeted to meet the higher performance requirements of ZigBee Pro and ZigBee IP based applications, especially Smart Energy and Commercial Building Automation. This product is a cost-effective solution that matches or exceeds competitive solutions.

Audience

This manual is intended for system designers.

Organization

This document is organized into the following chapters.

- Chapter 1 Safety Information — Highlights some of the FCC requirements.
- Chapter 2 MKW2xDxxx Development Platform Overview and Description — Provides an overview of the boards that comprise the MKW2xDxxx development platform.
- Chapter 3 USB-KW24D512 — This chapter details the USB-KW24D512 evaluation board.
- Chapter 4 PCB Manufacturing Specifications — This chapter provides the specifications used to manufacture the various MKW2xDxxx printed circuit boards (PCBs).

Revision History

The following table summarizes revisions to this document since the previous release (Rev. 0.0).

Revision History

Location	Revision
Entire document	First public release
Entire document	Rev. 0.1, Rename KW24512-USB to USB-KW24D512 development board.

Definitions, Acronyms, and Abbreviations

The following list defines the acronyms and abbreviations used in this document.

ADC	Analog to Digital Converter
AES	Advanced Encryption Standard
CTS	Clear to Send
DAC	Digital to Analog Converter
I2C	Inter-Integrated Circuit is a multi-master serial computer bus
ISM	Industrial Scientific Medical 2.4 GHz radio frequency band
JTAG	Joint Test Action Group
LGA	Land Grid Array
MAC	Media Access Controller
MCU	Microcontroller Unit
PCB	Printed circuit board
PiP	Platform in Package
PWM	Pulse-width modulation
RCM	Remote Control Module
REM	Remote Extender Board
RTS	Request to Send
SMA Connector	SubMiniature version “A” connector
SoC	System on Chip
SPI	Serial Peripheral Interface
SSI	Synchronous Serial Interface
TACT Switch	A switch that provides a slight “snap” or “click” to the user to indicate function.
TELCO	Telephone Company
TWR	Tower System
USB	Universal Serial Bus
VCP	Virtual Com Port

Chapter 1

Safety Information

1.1 FCC Guidelines

This equipment is for use by developers for evaluation purposes only and must not be incorporated into any other device or system. This device may not be sold to the general public. Integrators will be responsible for reevaluating the end product (including the transmitter) and obtaining a separate FCC authorization.

FCC approval of this device only covers the original configuration of this device as supplied. Any modifications to this product, including changes shown in this manual, may violate the rules of the Federal Communications Commission and Industry Canada and make operation of the product unlawful.

1.1.1 Labeling

FCC labels are physically located on the back of the board.

1.1.2 Operating Conditions

This device complies with part 15 of the FCC Rules. Operation is subject to the following two conditions:

- This device may not cause harmful interference.
- This device must accept any interference received, including interference that may cause undesired operation.

1.1.3 Exposure Limits

This equipment complies with FCC radiation exposure limits set forth for an uncontrolled environment. The antenna(s) used for this equipment must be installed to provide a separation distance of at least 8 inches (20cm) from all persons.

1.1.4 Antenna Restrictions

An intentional radiator is designed to ensure that no antenna other than that furnished by the responsible party is used with the device. The use of a permanently attached antenna or of an antenna that uses a unique coupling to the intentional radiator is considered sufficient to comply with the provisions of this Section. The manufacturer may design the unit so that a broken antenna can be replaced by the user, but the use of a standard antenna jack or electrical connector is prohibited. This requirement does not apply to carrier current devices or to devices operated under the provisions of Sections 15.211, 15.213, 15.217, 15.219, or 15.221. Further, this requirement does not apply to intentional radiators that must be professionally

installed, such as perimeter protection systems and some field disturbance sensors, or to other intentional radiators which, in accordance with Section 15.31(d), must be measured at the installation site. However, the installer is responsible for ensuring that the proper antenna is employed so that the limits in this Part are not exceeded.

1.2 Regulatory Approval For Canada (IC RSS 210)

This device complies with Industry Canada licence-exempt RSS standard(s). Operation is subject to the following two conditions:

1. This device may not cause interference, and
2. This device must accept any interference, including interference that may cause undesired operation of the device.

1.2.1 26 PART 5 – Appendix

Le présent appareil est conforme aux CNR d'Industrie Canada applicables aux appareils radio exempts de licence. L'exploitation est autorisée aux deux conditions suivantes:

1. l'appareil ne doit pas produire de brouillage, et
2. l'utilisateur de l'appareil doit accepter tout brouillage radioélectrique subi, même si le brouillage est susceptible d'en compromettre le fonctionnement.

1.3 Electrostatic Discharge Considerations

Although damage from electrostatic discharge (ESD) is much less common on these devices than on early CMOS circuits, normal handling precautions should be used to avoid exposure to static discharge. Qualification tests are performed to ensure that these devices can withstand exposure to reasonable levels of static without suffering any permanent damage.

All ESD testing is in conformity with the JESD22 Stress Test Qualification for Commercial Grade Integrated Circuits. During the device qualification ESD stresses were performed for the human body model (HBM), the machine model (MM) and the charge device model (CDM).

All latch-up test testing is in conformity with the JESD78 IC Latch-Up Test.

When operating or handling the development boards or components, Freescale strongly recommends using at least the grounding wrist straps plus any or all of the following ESD dissipation methods:

- Flexible fabric, solid fixed size, or disposable ESD wrist straps
- Static control workstations, static control monitors and table or floor static control systems
- Static control packaging and transportation materials and environmental systems

1.4 Disposal Instructions

This product may be subject to special disposal requirements. For product disposal instructions, refer to www.freescale.com/productdisposal.

Chapter 2

USB-KW24D512 Development Platform Overview and Description

2.1 Introduction

The USB-KW24D512 development platform is an evaluation environment based on the Freescale MKW24D512 SIP device (MKW2x).

The MKW2x device family is Freescale's latest generation ZigBee™ platform which incorporates a complete low power IEEE® 802.15.4 Standard 2.4 GHz radio frequency transceiver and a Kinetis family low power, mixed-signal ARM Cortex™- M4 MCU into a single package.

Freescale supplements the MKW2x with tools and software that include hardware evaluation and development boards, software development IDE and applications, drivers, custom PHY usable with Freescale's IEEE 802.15.4 compatible MAC.

The USB-KW24D512 development platform contains the MKW24D512 device with 32 MHz reference oscillator crystal, RF circuitry including antenna, and supporting circuitry in a USB stick hardware format. The board is a standalone and can be used for application development or as a packet sniffer.

Whether the USB-KW24D512 is used in a simple standalone application or in combination with another boards, Freescale provides a complete software development environment called the Freescale BeeKit Wireless Connectivity Toolkit (BeeKit). BeeKit is a comprehensive codebase of wireless networking libraries, application templates, and sample applications. A wide range of software functionality are available to complement the USB-KW24D512 platform and these are provided as codebases within BeeKit.

2.2 Board Features

2.2.1 USB-KW24D512 Board

The USB-KW24D512 development platform contains the MKW24D512 device and is one of the simplest reference designs utilizing the on chip USB block for power and communication. The USB-KW24D512 is a small form factor self-contained board for evaluation of wireless applications and can be used as packet sniffer. The USB Type A connection is used with USB enabled hardware such as a computer.

[Figure 2-1](#) shows the USB-KW24D512 development platform.



Figure 2-1. USB-KW24D512

The USB-KW24D512 development platform includes the following Features:

- Freescale’s low-power MKW24D512 SIP ZigBee™ platform
- Fully compliant IEEE 802.15.4 Standard 2006 transceiver supports 250 kbps O-QPSK data in 5.0 MHz channels and full spread-spectrum encode and decode.
- USB form factor for reference design and small footprint, low cost RF node
 - Differential input/output port used with external balun for single port operation
 - Low external component count
 - Programmable output power from -32 dBm to $+8$ dBm feed to the Antenna
 - Receiver sensitivity: -101 dBm, typical (@1% PER for 20 byte payload packet) feed to the antenna
- Integrated PCB Folded F-type antenna
- 32 MHz reference oscillator
- 2.4 GHz frequency operation (ISM)
- Programmable frequency clock output (CLK_OUT)
- Full speed USB 2.0
- Cortex 10-pin (0.05”) JTAG debug port for target MCU
- 2 blue LED indicators
- 1 push button switch
- 1 Reset push button

Figure 2-2 shows a simplified block diagram of the Freescale USB-KW24D512 board.

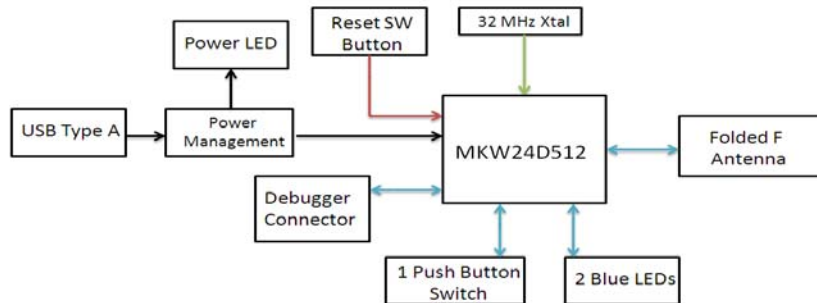

Figure 2-2. Simplified USB-KW24D512 Block Diagram

2.3 Software and Driver Considerations

Install the BeeKit Wireless Connectivity Toolkit package found under Software and Tools at the following URL before proceeding to use the boards:

- www.freescale.com/zigbee

When users first connect a KW2x based platform to a PC, they may be prompted to install drivers. Platform drivers can be found under the installation Beekit folder as denoted below. Once BeeKit is installed, do not allow Windows to automatically search for and install the drivers. Instead, select manual installation and steer Windows to the following directory:

- C:\Program Files\Freescale\Drivers

Follow the instructions as they appear on the screen to complete driver installation.

NOTE

If the BeeKit software package is installed in another drive or directory, indicate the Drivers proper folder location where BeeKit was installed.

If BeeKit is not installed, consider the following:

- When prompted, download the appropriate Windows driver and follow the instructions to complete the driver installation.
- The required drivers to be installed will depend on the reference design platform.
 - The KW2x boards come imaged with MSD OpenSDA firmware for board to PC connectivity. The target is pre-loaded with the SMAC Connectivity Test application.
 - Use the OpenSDA USB port (J15) to connect via Virtual COM Port (VCP) using P&E's OpenSDA Windows driver (See the TWR-OSDAUG.pdf guide).

For additional information about our 2.4 GHz Kinetis family ZigBee™ platforms, refer to the following:

- www.freescale.com/KW2x
- TWR-OSDAUG - OpenSDA User's Guide
- SMACDAUG - SMAC User's Guide

Chapter 3

USB-KW24D512

3.1 USB-KW24D512 Overview

The USB-KW24D512 is an evaluation board based on the Freescale MKW24D512 device. The USB-KW24D512 provides a platform to evaluate the USB-KW24D512 SIP IC, develop software and applications. The core device is accompanied by the 32 MHz reference oscillator crystal, RF circuitry including a printed board antenna, and supporting circuitry.

This basic board is intended as the core PCB for USB-KW24D512 evaluation and application development and can be used as a simple standalone evaluation solution or use a packet sniffer.

3.1.1 PCB Board Features

The USB-KW24D512 provides the following features:

- USB small form factor
- 4-Layer metal, 0.062 inch thick FR4 board
- LGA footprint and power supply bypass
- Printed metal folded F-Antenna
- 32 MHz reference oscillator crystal

3.1.2 Form Factor

Figure 3-1 shows the USB-KW24D512 connector and header locations.

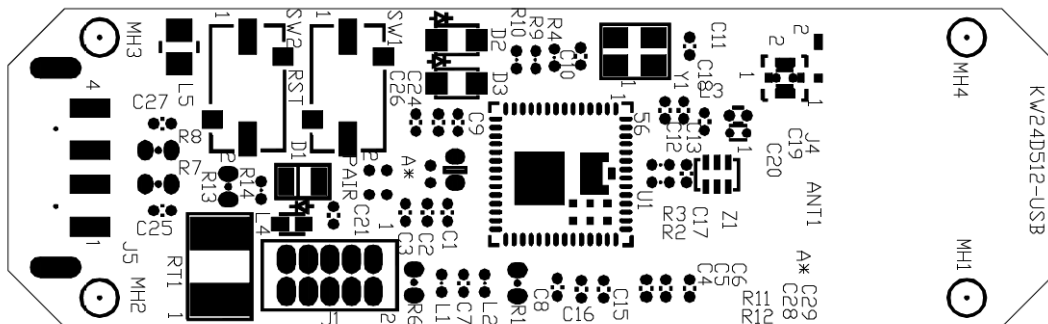

Figure 3-1. USB-KW24D512

Figure 3-2 shows a footprint of the USB-KW24D512 with the location of the header and connectors

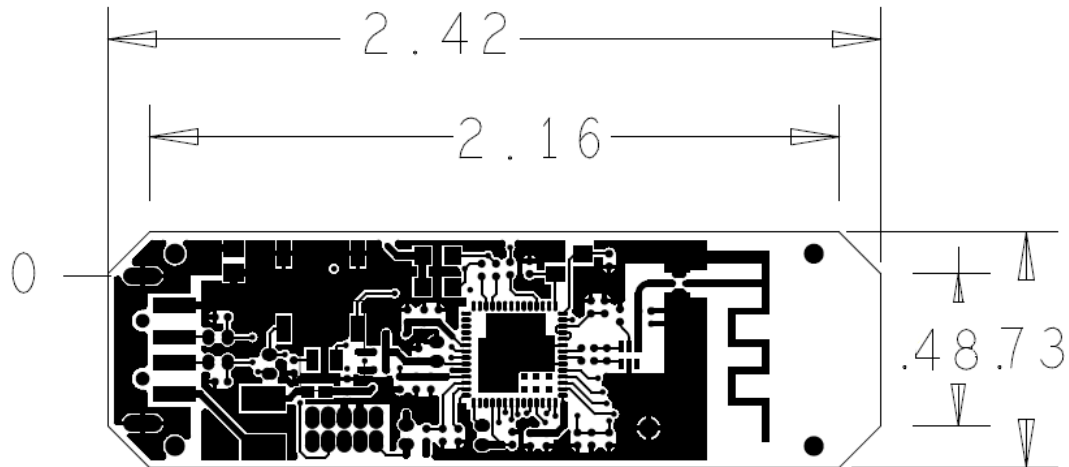

Figure 3-2. USB-KW24D512 Top Side (Component Side) Footprint

3.1.3 Board Level Specifications

Table 3-1. USB-KW24D512 Specifications

Parameter	Min	Typ	Max	Units	Notes/Conditions
General					
Size (PCB: X, Y)			61.4 x 18.5 2.42 x 0.73	mm inches	
Layer build (PCB)		1.57 0.062		mm inches	4-Layer
Dielectric material (PCB)					FR4
Power					
Current consumption				mA	Refer to datasheet
Temperature					
Operating temperature (see note)	-40	+25	+70	°C	• Operating temperature is limited to +70 °C due to switches. Basic circuit is good for a maximum temperature of +85 °C.
Storage temperature	-30	+25	+70	°C	
RF					
802.15.4 Frequency range	2405		2480	MHz	All 16 channels in the 2450 MHz band
RF Receiver					
Saturation (maximum input level)		+10		dBm	Datasheet
Sensitivity for 1% packet error rate (PER) (+25 °C)		-102		dBm	Datasheet
RF Transmitter					

Table 3-1. USB-KW24D512 Specifications (continued)

Parameter	Min	Typ	Max	Units	Notes/Conditions
RF Power Output	-32		+8	dBm	Programmable in 2dB steps. At the antenna feed with no trap. ¹ .
2nd harmonic		<-50	<-40	dBm	Datasheet
3rd harmonic		<-50	<-40	dBm	Datasheet
Regulatory Approval					
FCC					Product is approved accordingly to the FCC part 15 standard
CE (ETSI)					Product is approved accordingly to the EN 300 328 V1.7.1 (2006-10) standard
CE (EMC)					Product is approved accordingly to the EN 301 489-1 V1.6.1 (2005-09) and EN 301 489-17 V1.2.1 (2002-08) standards
Safety					
UL					Product is approved accordingly to the IEC 60950-1 and EN 60950-1, First Edition standards
Environment					
RoHS					Product complies with the EU Directive 2002/95/EC of 27 January 2003
WEEE					Product complies with the EU Directive 2002/95/EC of 27 January 2003

¹ Trap will add 1 to 2 dB of loss.

3.2 Functional Description

The USB-KW24D512 is built around Freescale's MKW24D512 63-pin (56-pin usable) LGA platform. This board is intended as a simple evaluation platform and as a building block for application development. The 4-layer board provides the MKW24D512 with its required RF circuitry, 32 MHz reference oscillator crystal, and power supply bypassing. The layout for this base level functionality can be used as a reference layout by the user target board. [Figure 3-3](#) shows a simple block diagram.

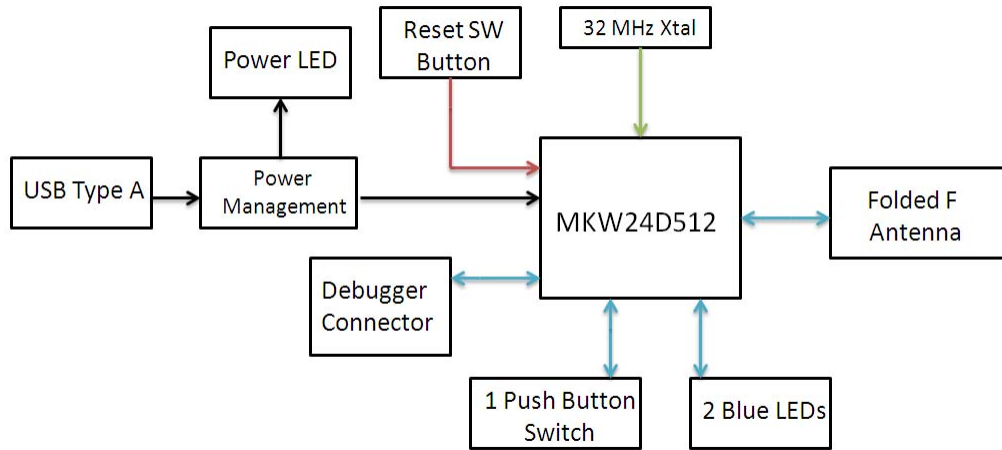

Figure 3-3. USB-KW24D512 Block Diagram

3.2.1 RF Performance and Considerations

USB-KW24D512 transceiver includes a 1mW nominal output power, PA with internal voltage controlled oscillator (VCO), integrated transmit/receive switch, on-board power supply regulation, and full spread-spectrum encoding and decoding. The USB-KW24D512 utilizes a minimum number of components while providing good RF performance. Key specifications for USB-KW24D512 are:

- Nominal output power is set to 0 dBm
- Programmable output power from -32 dBm to +8 dBm measured at the antenna feed
- Typical sensitivity is -101 dBm (@1% PER for 25 °C) measured at the antenna feed
- Frequency range is 2360 to 2480 MHz
- Folded “F” printed metal antenna for a small footprint, low cost design
- Uses a minimum number of RF marching components and external 50:50 balun

An external 50 (unbal): 50(bal) balun connects a single-ended 50-ohm port to the differential RF port of the MKW24D512 radio. The layout has provision for out-of-band signal suppression (components L5 and C19) if required. Figure 3-4 shows the typical topology for the RF circuitry. The RF switch J4 has been designed in for measurement purposes and is left as DNP.

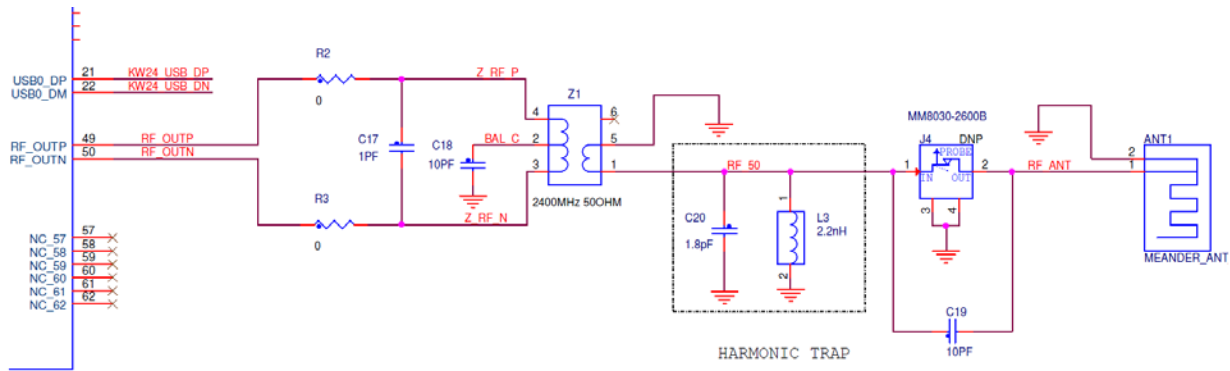

Figure 3-4. USB-KW24D512 RF Circuitry

3.2.2 Clocks

The USB-KW24D512 provides one clock:

- 32 MHz Reference Oscillator — [Figure 3-5](#) shows the external 32 MHz external crystal Y1. This mounted crystal must meet the specifications outlined in the AN3251 application note. The IEEE 802.15.4 Standard requires that the frequency be accurate to less than ± 40 ppm.
 - Capacitors C10 and C11 provide the bulk of the crystal load capacitance. Onboard trim capacitors can be programmed to center the frequency. At 25°C, it is desired to have the frequency accurate to ± 10 ppm or less to allow for temperature variation.
 - To measure the 32 MHz oscillator frequency, signal CLK_OUT (TP5) can optionally be programmed to provide a buffered output clock signal.

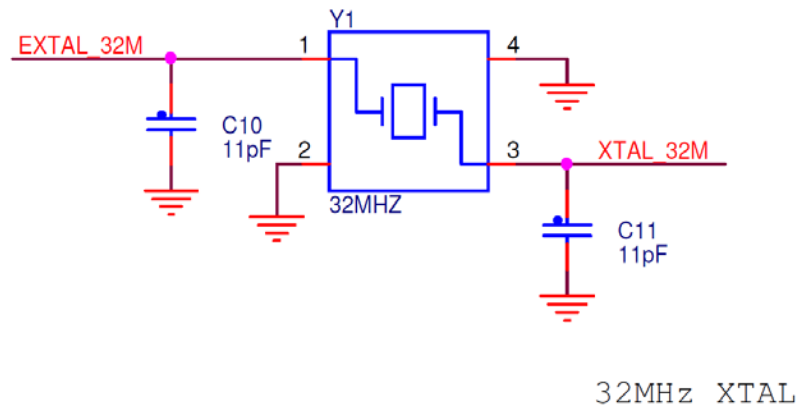

Figure 3-5. USB-KW24D512 32 MHz Reference Oscillator Circuit

3.2.3 Power Management

The USB-KW24D512 power management circuit is shown in [Figure 3-6](#).

3.3 Schematic, Board Layout, and Bill of Material

Figure 3-7. USB-KW24D512 Schematic

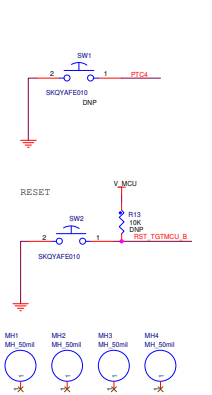
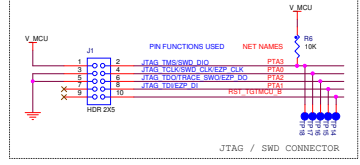
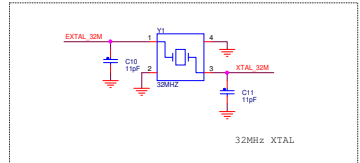
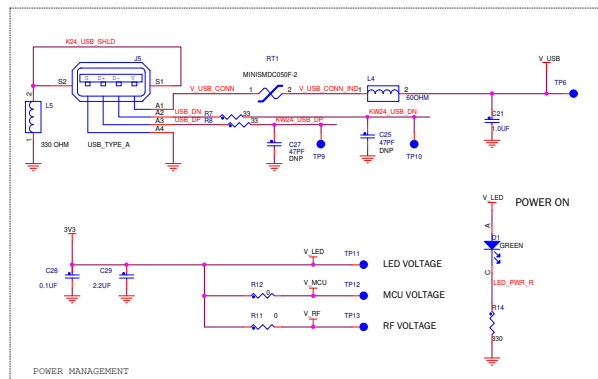
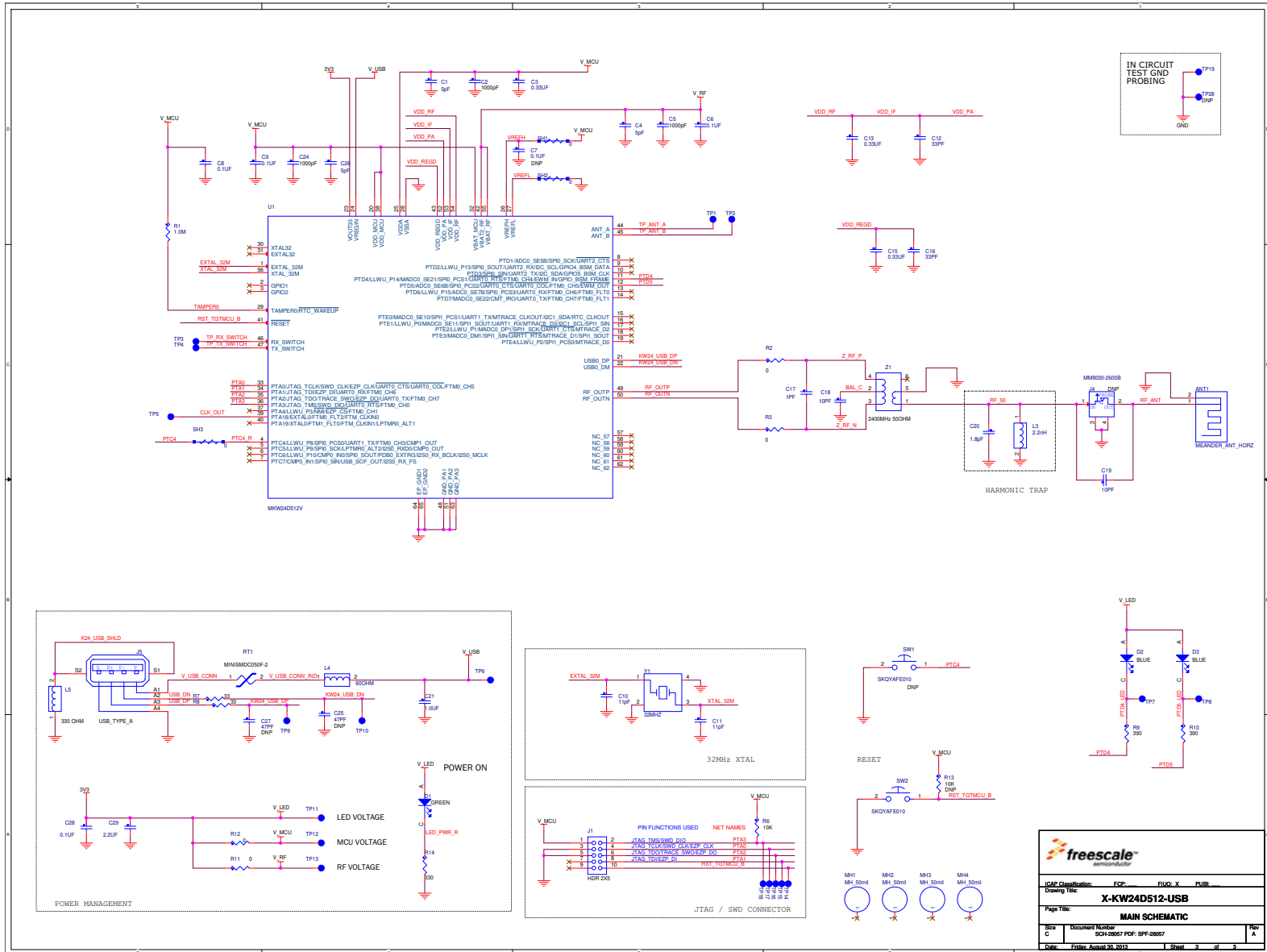

freescale Microsemi	
ICAP Classification:	EEP, EMO, X, PUR
Device ID:	X-KW24D512-USB
Page Title:	MAIN SCHEMATIC
Doc ID:	Document Number: 6591-28857-100-00000000
Date:	File Name: SW_2013_1_Schem_3 of 3

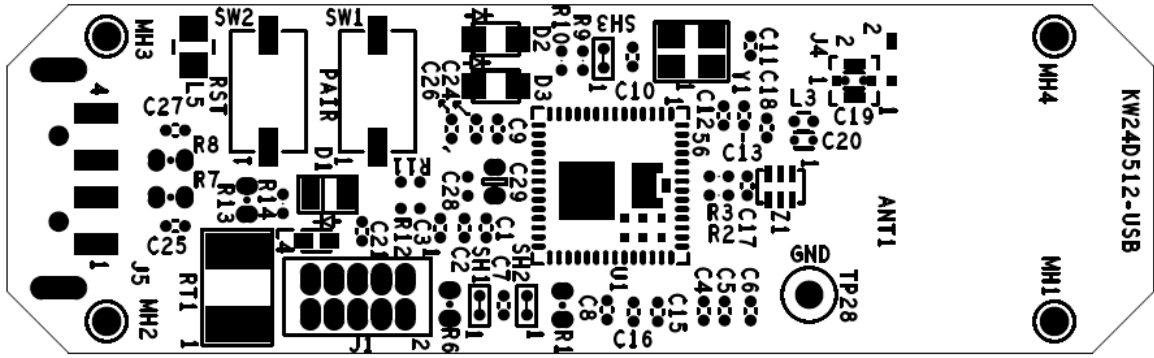

Figure 3-8. USB-KW24D512 Reference Board PCB Component Location (Top View)

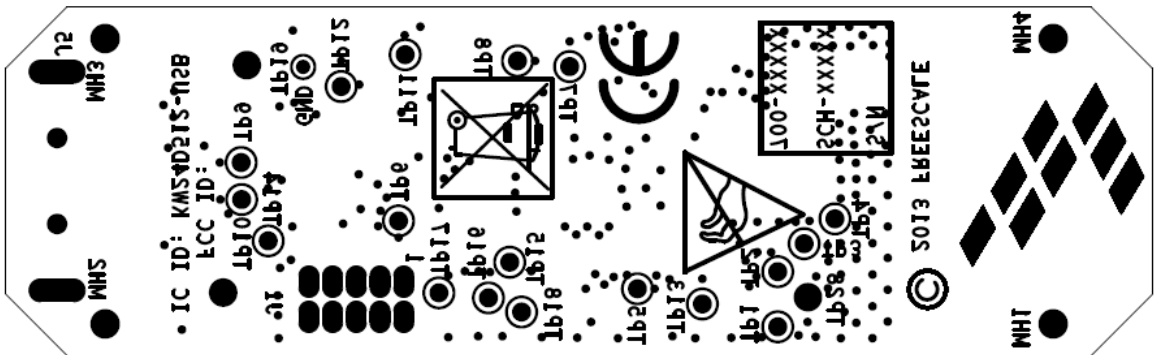

Figure 3-9. USB-KW24D512 Reference Board PCB Test Points

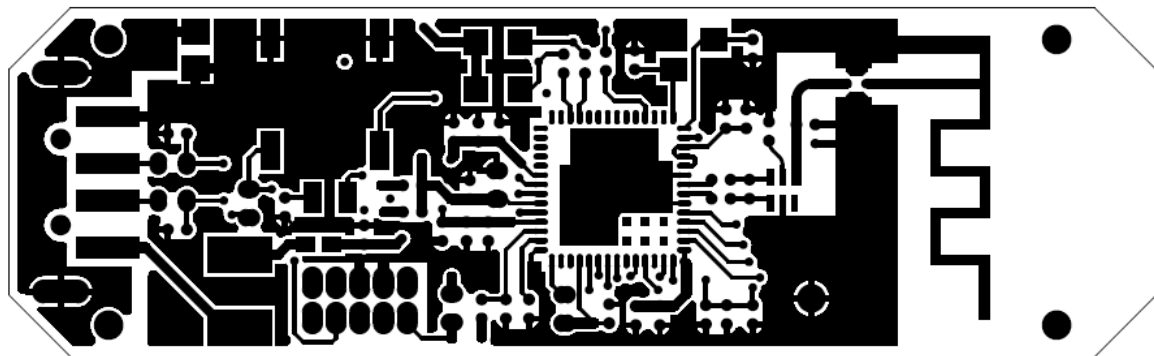

Figure 3-10. USB-KW24D512 Reference Board PCB Layout (Top View)

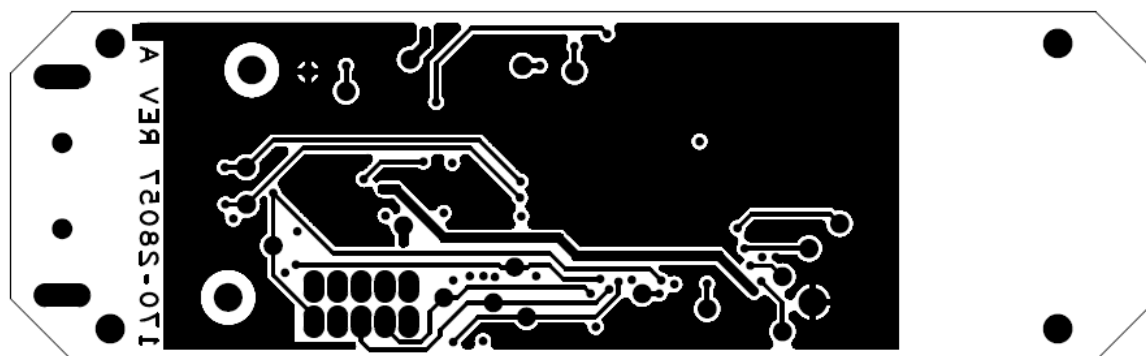

Figure 3-11. USB-KW24D512 Reference Board PCB Layout (Bottom View)

3.3.1 Bill of Materials

Table 3-2. Bill of Materials (Common parts for all frequency bands) (Sheet 1 of 3)

Item	Qty	Reference	Value	Description	Mfg. Name	Mfg. Part Number
1	1	ANT1	MEANDER_ ANT_HORZ	PCB MEANDER ANTENNA HORIZONTAL, NO PART ORDER		
2	3	C1,C4,C26	5pF	CAP CER 5pF 50V 5% C0G 0402	MURATA	GJM1555C1H5R0CB01D
3	3	C2,C5,C24	1000pF	CAP CER 1000PF 50V 5% C0G 0402	MURATA	GRM1555C1H102JA01D
4	3	C3,C13,C15	0.33UF	CAP CER 0.33UF 6.3V 10% X5R 0402	MURATA	GRM155R60J334KE01D
5	4	C6,C8,C9,C28	0.1UF	CAP CER 0.1UF 16V 10% X7R 0402	KEMET	C0402C104K4RAC
6	1	C7 DNP	0.1UF	CAP CER 0.1UF 16V 10% X7R 0402	KEMET	C0402C104K4RAC
7	2	C10,C11	11pF	CAP CER 11pF 50V 5% C0G 0402	TDK	C1005C0G1H110J
8	2	C12,C16	33PF	CAP CER 33PF 50V 5% C0G 0402	VENKEL COMPANY	C0402C0G500-330JNE
9	1	C17	1PF	CAP CER 1PF 50V 5% C0G 0402	MURATA	GRM1555C1H1R0CA01B
10	2	C18,C19	10PF	CAP CER 10PF 50V 5% C0G 0402	AVX	04025A100JAT2A
11	1	C20	1.8pF	CAP CER 1.8PF 50V 0.25PF C0G 0402	MURATA	GRM1555C1H1R8CA01D
12	1	C21	1.0UF	CAP CER 1.0UF 10V 10% X5R 0402	YAGEO AMERICA	CC0402KRX5R6BB105

Table 3-2. Bill of Materials (Common parts for all frequency bands) (Sheet 2 of 3)

Item	Qty	Reference	Value	Description	Mfg. Name	Mfg. Part Number
13	2	C25,C27 DNP	47PF	CAP CER 47PF 16V 5% C0G 0402	AVX	0402YA470JAT2A
14	1	C29	2.2UF	CAP CER 2.2UF 10V 10% X7R 0603	TAIYO YUDEN	LMK107B7225KA-T
15	1	D1	GREEN	LED GRN SGL 30MA SMT 0805	LITE ON	LTST-C171KGKT
16	2	D2,D3	BLUE	LED BLUE SGL 20MA SMT 0805	LITE ON	LTST-C171TBKT
17	1	J1	HDR 2X5	CONN,HEAD,2X5,STR,50/50 CON-2RH-10-50	SAMTEC	FTS-105-01-F-D
18	1	J4 DNP	MM8030-26 00B	CON COAX SMT 1.9MM SP 40H AU	MURATA	MM8030-2610B
19	1	J5	USB_TYPE _A	CON 1X4 USB_TYPE_A_MALE RA SMT -- 178H AU	SAMTEC	USB-AM-S-S-B-SM1
20	1	L3	2.2nH	IND -- 2.2NH@500MHZ 220mA 4% 0402	MURATA	LQP15MN2N2B02
21	1	L4	60OHM	IND FER BEAD 60OHM@100MHZ 500MA -- 0603	MURATA	BLM18PG600SN1D
22	1	L5	330 OHM	IND FER BEAD 330OHM@100MHZ 2.5A -- SMT	TDK	MPZ2012S331A
23	4	MH1,MH2, MH3,MH4	MH_50mil	Rework Hole Non-Plated 50mil Drill size 65mil Soldermask TH, NO PART TO ORDER		
24	1	RT1	MINISMDC 050F-2	FUSE PLYSW 0.5A 24V SMT	TYCO ELECTRONICS	MINISMDC050F-2
25	1	R1	1.0M	RES MF 1.0M 1/10W 5% 0603	BOURNS	CR0603-JW-105ELF
26	4	R2,R3,R11, R12	0	RES MF ZERO OHM 1/16W 5% 0402	ROHM	MCR01MZPJ000
27	1	R6	10K	RES MF 10K 1/10W 5% 0603	KOA SPEER	RK73B1JTDD103J
28	2	R7,R8	33	RES MF 33 OHM 1/10W 5% 0603	VISHAY INTERTECHNOLOGY	CRCW060333R0JNE A
29	2	R9,R10	390	RES MF 390 OHM 1/16W 5% 0402	VISHAY INTERTECHNOLOGY	CRCW0402390RJNE D
30	1	R13 DNP	10K	RES MF 10K 1/10W 5% 0603	KOA SPEER	RK73B1JTDD103J
31	1	R14	330	RES MF 330 OHM 1/16W 5% 0402	VISHAY INTERTECHNOLOGY	CRCW0402330RJNE D
32	3	SH1,SH2,S H3	0	ZERO OHM CUT TRACE 0402 PADS; NO PART TO ORDER		
33	1	SW1 DNP	SKQYAFE0 10	SW SPST MOM PB 50MA 12V SMT	ALPS ELECTRIC (USA) INC.	SKQYAFE010
34	1	SW2	SKQYAFE0 10	SW SPST MOM PB 50MA 12V SMT	ALPS ELECTRIC (USA) INC.	SKQYAFE010

Table 3-2. Bill of Materials (Common parts for all frequency bands) (Sheet 3 of 3)

Item	Qty	Reference	Value	Description	Mfg. Name	Mfg. Part Number
35	18	TP1,TP2,TP3,TP4,TP5,TP6,TP7,TP8,TP9,TP10,TP11,TP12,TP13,TP14,TP15,TP16,TP17,TP18	TPAD_040	TEST POINT PAD 40MIL DIA SMT, NO PART TO ORDER		
36	1	TP19	TPAD_030	TEST POINT PAD 30MIL DIA SMT, NO PART TO ORDER		
37	1	TP28 DNP	TEST POINT WHITE	TEST POINT WHITE 40 MIL DRILL 180 MIL TH 109L	COMPONENTS CORPORATION	TP-105-01-09
38	1	U1	MKW24D512V	IC MCU XCVR 2.4GHZ 64KB RAM 512KB FLASH - USB 1.8-3.6V LGA63	Freescale Semiconductor	MKW24D512VHA5
39	1	Y1	32MHZ	XTAL 32MHZ 9PF -- SMT 3.2X2.5MM	NDK	EXS00A-CS02368
40	1	Z1	2400MHz 50OHM	XFMR BALUN 2400 +/-100MHZ SMT	MURATA	LDB212G4005C-001

Chapter 4

PCB Manufacturing Specifications

This chapter provides the specifications used to manufacture the KW2x Development hardware printed circuit board (PCB) described in this manual.

The KW2x Development hardware PCBs must comply with the following:

- The PCB must comply with Perfag1D/3C (<http://www.perfag.dk/Uk/ukindex.htm>)
- The PCB manufacturer's logo is required
- The PCB production week and year code is required
 - The manufacturer's logo and week/year code must be stamped on the back of the PCB solder mask
 - The PCB manufacturer can not insert text on the PCB either in copper or in silkscreen without written permission from Freescale Semiconductor, Inc.
- The required Underwriter's Laboratory (UL) Flammability Rating
 - The level is 94V-0 (<http://www.ul.com/plastics/flame.html>)
 - The UL information must be stamped on the back of the PCB solder mask

NOTE

- A complete set of design files is available for the KW2x Development hardware at the Freescale web site (<http://www.freescale.com/KW2x>) under the "Software and Tools" tab. This design or one of a number of other reference designs should be used as a starting point for a custom application.
- The *Freescale IEEE 802.15.4 / ZigBee Package and Hardware Layout Considerations Reference Manual*, (ZHDCRM) is also available at the same web site to provide additional design guidance.

4.1 Single PCB Construction

This section describes individual PCB construction details.

- The USB-KW24D512 PCB is four-layer, multi layer design
- The PCBs contains no blind, buried, or micro vias
- PCB data:
 - USB-KW24D512 Size: Approximately 61.4 x 18.5mm (2.42 x 0.73 inches)
 - USB-KW24D512 Final thickness (Cu/Cu): 1.57 mm (0.62 inches) +/- 10% (excluding solder mask)

The following table defines some of the layers of the completed PCB. The artwork identification refers to the name of the layer in commonly used terms.

Table 4-1. USB-KW24D512 Layer by Layer Overview

Layer	Artwork Identification	File Name
1	Silkscreen Top	SILK_TOP.art
2	Top Layer Metal	TOP.art
3	Ground Layer	GND.art
4	Power Layer	PWR.art
5	Bottom Layer Metal	BOTTOM.art
6	Silkscreen Bottom	SILK_BOTTOM.art

NOTE

The USB-KW24D512 contains high frequency 2.4 GHz RF circuitry. As a result, RF component placement, line geometries and layout, and spacing to the ground plane are critical parameters. As a result, BOARD STACKUP GEOMETRY IS CRITICAL. Dielectric and copper thicknesses and spacing must not be changed; follow the stackup (see Figure 4-1) information is provided with the reference design.

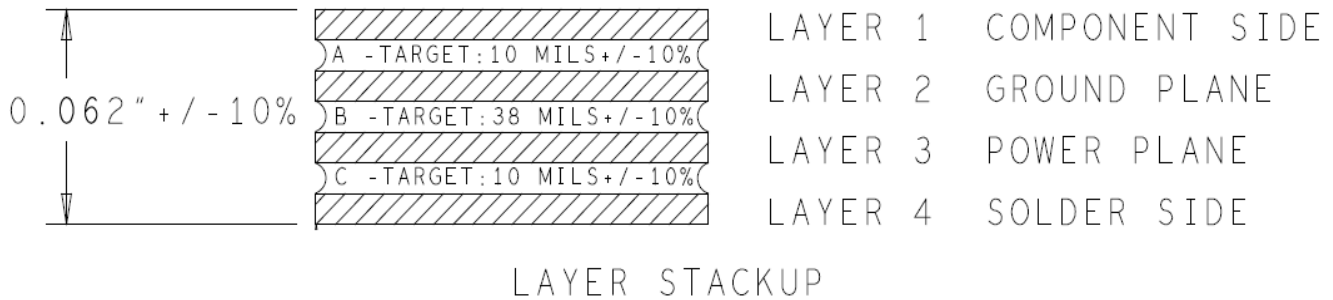

Figure 4-1. USB-KW24D512 PCB Stackup Cross-Section (Four Layer)

- Solder mask is required
- Silk screen is required

4.2 Panelization

The panel size can be negotiated depending on production volume.

4.3 Materials

The PCB composite materials must meet the following requirements:

- Laminate - The base laminate material (laminate) must be FR4. If the laminate material were changed the RF electrical characteristics may change and degrade RF performance.
- Copper Foil -
 - Top and Bottom copper layers must be 1 oz. copper
 - Interior layers must be 1oz. copper
- Plating - All pad plating must be Hot Air Levelling (HAL)

4.4 Solder Mask

The solder mask must meet the following requirements:

- Solder mask type: Liquid Film Electra EMP110 or equivalent
- Solder mask thickness: 10 – 30 μm

4.5 Silk Screen

The silk screen must meet the following requirements:

- Silkscreen color: White
- Silkscreen must be applied after application of solder mask if solder mask is required
- The silkscreen ink must not extend into any plated-thru-holes
- The silk screen must be clipped back to the line of resistance

4.6 Electrical PCB Testing

- All PCBs must be 100 percent tested for opens and shorts
- Impedance Measurement - An impedance measurement report is not mandatory

4.7 Packaging

Packaging for the PCBs must be the following requirements:

- Finished PCBs must remain in panel
- Finished PCBs must be packed in plastic bags that do not contain silicones or sulphur materials. These materials can degrade solderability.

4.8 Hole Specification/Tool Table

See the `ncdrill-1-4.tap` file included with the Gerber files and the `FAB-28057.pdf` file.

4.9 File Description

Files included with the download include Design, Gerber and PDF files.

Gerber files are RS-274x format. Not all files included with the Gerber files are for PCB manufacturing.

PDF files included are:

- FAB-28057.pdf — USB - Board fabrication drawing
- GRB-28057.zip — USB - Metal layers, solder mask, solder paste and silk screen
- SPF-28057.pdf — USB - Schematic

Design files are in Allegro format with OrCAD schematic capture.