

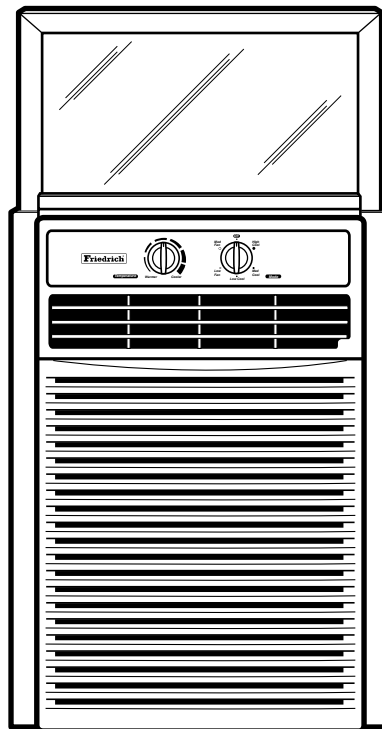

Room Air Conditioner Service and Parts Manual



Slider Casement

115Volts • SV08A10A • SV10A10A • SV12A10A

CONTENTS

1. PREFACE

1.1 SAFETY PRECAUTIONS.....	2
1.2 INSULATION RESISTANCE TEST.....	2
1.3 SPECIFICATIONS.....	3
1.4 FEATURES.....	4
1.5 CONTROL LOCATIONS	4

2. DISASSEMBLY INSTRUCTIONS

2.1 MECHANICAL PARTS	5
2.1.1 FRONT GRILLE	5
2.1.2 CABINET	5
2.1.3 CONTROL BOX	5
2.2 AIR HANDLING PARTS	6
2.2.1 AIR GUIDE AND TURBO FAN.....	6
2.2.2 FAN	6
2.2.3 SHROUD	7
2.3 ELECTRICAL PARTS.....	7
2.3.1 OVERLOAD PROTECTOR.....	7
2.3.2 COMPRESSOR.....	7
2.3.3 CAPACITOR.....	8
2.3.4 POWER CORD	8
2.3.5 THERMOSTAT	8
2.3.6 ROTARY SWITCH	8
2.3.7 MOTOR	9

2.4 REFRIGERATION CYCLE	9
2.4.1 CONDENSER.....	9
2.4.2 EVAPORATOR.....	9
2.4.3 CAPILLARY TUBE	10

3. INSTALLATION

3.1 HOW TO INSTALL THE UNIT.....	12
3.2 CHECKING INSTALLATION	12
3.3 HOW TO DRAIN.....	12
3.4 WINDOW REQUIREMENTS	13
3.5 INSTALLATION KITS CONTENTS	13
3.6 HORIZONTAL SLIDING WINDOW INSTALLATION	14
3.7 CASEMENT WINDOW INSTALLATION	15

4. TROUBLESHOOTING GUIDE

4.1 OUTSIDE DIMENSIONS	16
4.2 PIPING SYSTEM.....	16
4.3 TROUBLESHOOTING GUIDE	17

5. SCHEMATIC DIAGRAM

5.1 CIRCUIT DIAGRAM	21
5.2 CIRCUIT DIAGRAM	22

6. EXPLODED VIEW

7. REPLACEMENT PARTS LIST

1. PREFACE

This SERVICE MANUAL provides various service information, including the mechanical and electrical parts etc. This room air conditioner was manufactured and assembled under a strict quality control system. The refrigerant is charged at the factory. Be sure to read the safety precautions prior to servicing the unit.

1.1 SAFETY PRECAUTIONS

1. When servicing the unit, set the ROTARY SWITCH or POWER SWITCH to OFF and unplug the power cord.
2. Observe the original wire insulation.
If a short circuit is found, replace all parts which have been overheated or damaged by the short circuit.
3. After servicing the unit, make an insulation resistance test to protect the customer from being exposed to shock hazards.

1.2 INSULATION RESISTANCE TEST

1. Unplug the power cord and connect a jumper between 2 pins (black and white).
2. The grounding conductor (green) is to be open.
3. Measure the resistance value with an ohm meter between the jumpered lead and each exposed metallic part on the equipment at all the positions (except OFF) of the ROTARY SWITCH.
4. The value should be over 1MΩ.

1.3 SPECIFICATIONS

1.3.1 FOR SV08A10A / SV10A10A / SV12A10A

ITEMS		MODELS	SV08A10A	SV10A10A	SV12A10A
POWER SUPPLY			1Ø115V, 60Hz		
COOLING CAPACITY	(Btu/h)		8,000	10,000	12,000
INPUT	(W)		840	1,050	1,260
RUNNING CURRENT	(A)		7.7	9.6	11.5
E.E.R	(BTU/W·h)		9.5		
OPERATING CONDITION	INDOOR (°C)		26.7(DB)*	19.4(WB)**	
	OUTDOOR (°C)		35(DB)*	23.9(WB)**	
REFRIGERANT (R-22) CHARGE			460g(16.2 oz)	520g(18.3 oz)	615g(21.7 oz)
EVAPORATOR			2 ROW 16 STACKS, SLIT FIN TYPE	3 ROW 16 STACKS, SLIT FIN TYPE	
CONDENSER			2 ROW 23 STACKS, LOUVER FIN TYPE		3 ROW 23 STACKS, LOUVER FIN TYPE
FAN, INDOOR			TURBO FAN		
FAN, OUTDOOR			AXIAL FAN		
FAN SPEEDS, FAN/COOLING			2/3		
FAN MOTOR			6 POLES		
OPERATION CONTROL			ROTARY SWITCH		
ROOM TEMP. CONTROL			THERMOSTAT		
AIR DIRECTION CONTROL			VERTICAL LOUVER (RIGHT & LEFT)		
			HORIZONTAL LOUVER (UP & DOWN)		
CONSTRUCTION			TOP-DOWN CHASSIS		
PROTECTOR	COMPRESSOR		OVERLOAD PROTECTOR		
	FAN MOTOR		INTERNAL THERMAL PROTECTOR		
POWER CORD			3 WIRE WITH GROUNDING		
			ATTACHMENT PLUG (CORD-CONNECTED TYPE)		
DRAIN SYSTEM			DRAIN PIPE SPLASHED BY FAN SLINGER		
NET WEIGHT	(lbs/kg)		66/30	77/35	79/36
OUTSIDE DIMENSION (W x H x D)	(inch)		14 ¹ / ₂ x 20 ¹ / ₂ x 23 ³ / ₅		
	(mm)		368 x 521 x 607		

* DB:Dry Bulb

**WB:Wet Bulb

1.4 FEATURES

- Designed for COOLING ONLY.
- Powerful and whispering cooling.
- Simple installation and service.
- Low air-intake, top cooled-air discharge.

- Built-in adjustable THERMOSTAT
- Washable one-touch filter
- Compact size
- Reliable and efficient rotary compressor is equipped.

1.5 CONTROL LOCATIONS

1.5.1 COOLING ONLY MODEL

• VENTILATION

The ventilation lever must be in the CLOSE position in order to maintain the best cooling conditions.

When fresh air is necessary in the room, set the ventilation lever OPEN position.

The damper is opened and room air is exhausted.

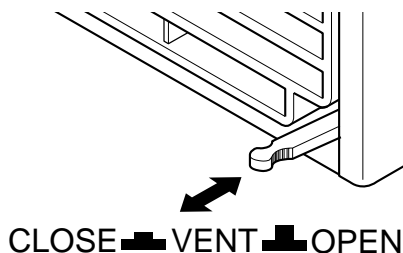

• TEMPERATURE

Thermostat will automatically control the temperature of the room. Select a higher grade for a cooler temperature in the room. The temperature is selected by moving the knob to the desired position.

• MODE

OFF - Turns air conditioner off.

MED FAN - Med speed fan operation without cooling.

LOW FAN - Low speed fan operation without cooling.

HI COOL - Cooling with high speed fan operation.

MED COOL - Cooling with med speed fan operation.

LOW COOL - Cooling with low speed fan operation.

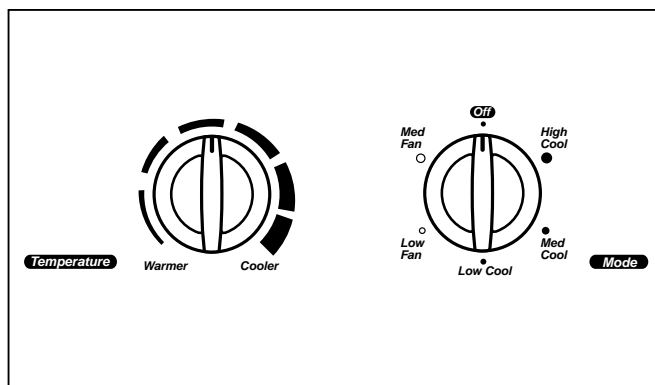

NOTE!

Before using the air conditioner secure the front grille with two screws enclosed with the owner's manual.

1. Open the inlet grille downward and remove the air filter.
2. Fasten the front grille with screws.
3. Reinstall the air filter.
4. Close the inlet grille.

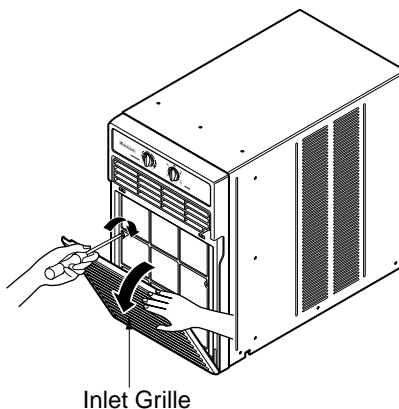

2. DISASSEMBLY INSTRUCTIONS

— Before the following disassembly, set POWER SWITCH to OFF and disconnect the power cord.

2.1 MECHANICAL PARTS

2.1.1 FRONT GRILLE

1. Open the inlet grille downward and remove the air filter.
2. Remove the screws which fasten the front grille.(See Figure 1)
3. Pull the front grille from the right side.
4. Remove the front grille.(There are 4 hooks.)
5. Re-install the components by referring to the removal procedure, above.

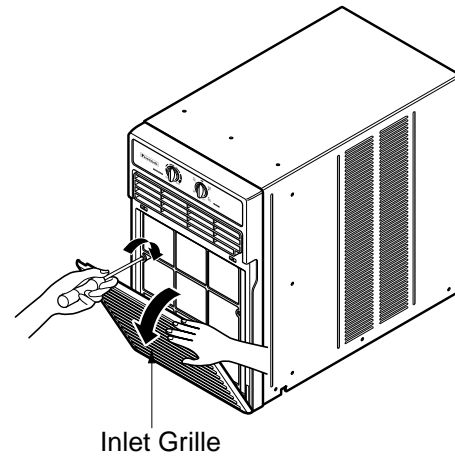

Figure 1

2.1.2 CABINET

1. After disassembling the FRONT GRILLE, remove the 6 screws which fasten the cabinet at both sides.(See Figure 2)
2. Remove the 4 screws which fasten the cabinet at back.
3. Remove the cabinet.
4. Re-install the components by referring to the removal procedure, above.

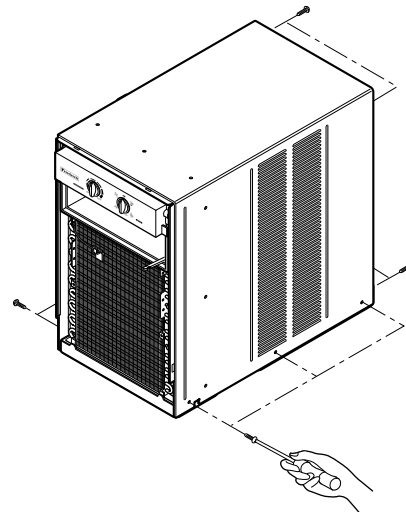

Figure 2

2.1.3 CONTROL BOX

1. Remove the front grille. (Refer to section 2.1.1)
2. Remove the cabinet. (Refer to section 2.1.2)
3. Remove the 1 screw which fasten the power cord. (See Figure 3)
4. Disconnect the grounding screw from the evaporator channel.
5. Remove the 2 screws which fasten the control box.(See Figure 3)
6. Remove the housing which connects motor wire in the control box.
7. Remove three leads which connect compressor.
8. Discharge the capacitor by placing a 20,000 ohm resistor across the capacitor terminals.
9. Raise the control box upward completely.
10. Re-install the components by referring to the removal procedure, above.
(Refer to the circuit diagram found on pages 21~22 in this manual and on the control box.)

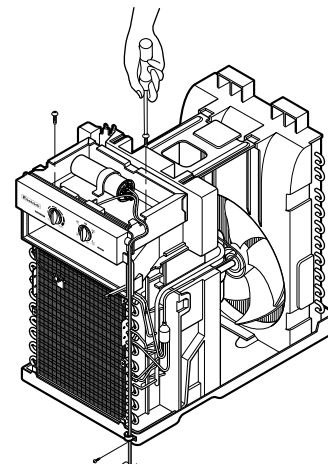

Figure 3

2.2 AIR HANDLING PARTS

2.2.1 AIR GUIDE AND TURBO FAN

1. Remove the front grille. (Refer to section 2.1.1)
2. Remove the cabinet. (Refer to section 2.1.2)
3. Remove the control box. (Refer to section 2.1.3)
4. Remove the 4 screws which fasten the brace.
5. Remove the brace.
6. Remove the 2 screws which fasten the upper air guide. (See Figure 4)
7. Remove the upper air guide.
8. Remove the 2 screws which fasten the evaporator.
9. Move the evaporator forward while pulling it upward slightly. (See Figure 5)
10. Remove orifice by pulling two taps.
11. Remove the clamp with a hand plier which secures the turbo fan.
12. Remove the turbo fan. (See Figure 6)
13. Remove the motor. (Refer to section 2.3.7)
14. Remove the 2 screws which fastens the lower air guide from the base pan.
15. Remove the 2 screws which fasten the motor mount from the base pan.
16. Remove the 2 screws which fasten the lower air guide and motor mount.
17. Move the lower air guide backward and pull out from the base pan. (Move the lower air guide carefully.)
18. Re-install the components by referring to the removal procedure, above.

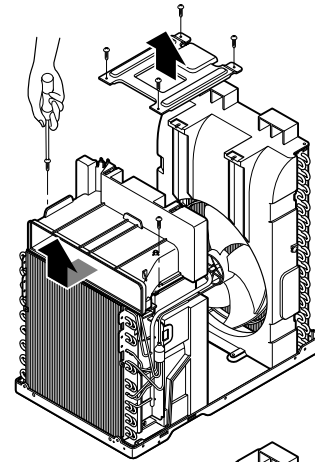

Figure 4

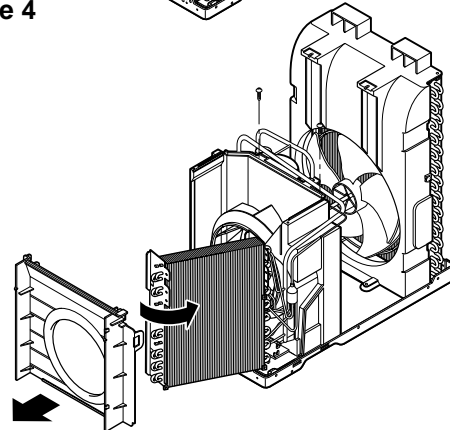

Figure 5

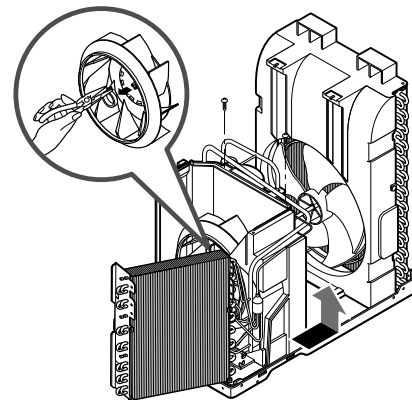

Figure 6

2.2.2 FAN

1. Remove the cabinet. (Refer to section 2.1.2)
2. Remove the brace (Refer to section 2.2.1)
3. Remove 6 screws which fasten the condenser.
4. Move the condenser to the right carefully.
5. Remove the clamp which secures the fan with a pair of hand pliers.
6. Remove the fan. (See Figure 7)
7. Re-install by referring to the removal procedure.

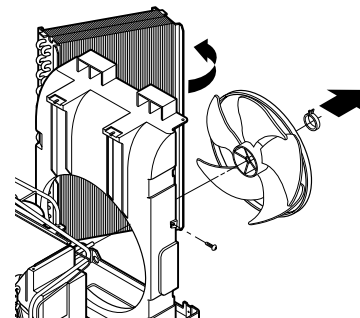

Figure 7

2.2.3 SHROUD

1. Remove the fan. (Refer to section 2.2.2)
2. Remove the shroud. (See Figure 8)
3. Re-install the components by referring to the removal procedure, above.

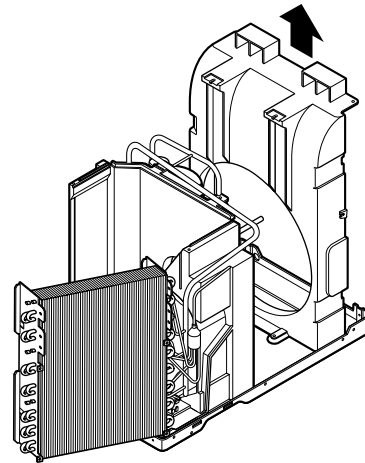

Figure 8

2.3 ELECTRICAL PARTS

2.3.1 OVERLOAD PROTECTOR

1. Remove the cabinet. (Refer to section 2.1.2)
2. Remove the nut which fastens the terminal cover.
3. Remove the terminal cover. (See Figure 9)
4. Remove all the leads from the overload protector.
5. Remove the overload protector.
6. Re-install the components by referring to the removal procedure, above.

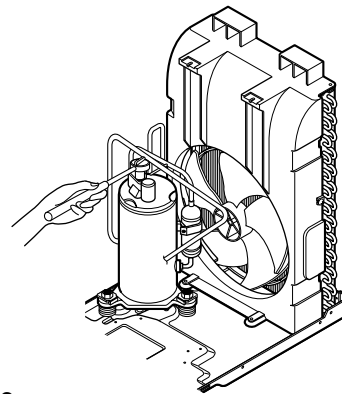

Figure 9

2.3.2 COMPRESSOR

1. Remove the cabinet. (Refer to section 2.1.2)
2. Discharge the refrigerant system using a Freon™ Recovery System.
If there is no valve to attach the recovery system to install one (such as a WATCO A-1) before venting the Freon™. Leave the valve in place after servicing the system.
3. Remove the overload protector. (Refer to section 2.3.1)
4. After purging the unit completely, unbrazed the suction and discharge tubes at the compressor connections.
5. Remove the 3 nuts and the 3 washers which fasten the compressor to the base pan.
6. Remove the compressor. (See Figure 10)
7. Re-install the components by referring to the removal procedure, above.

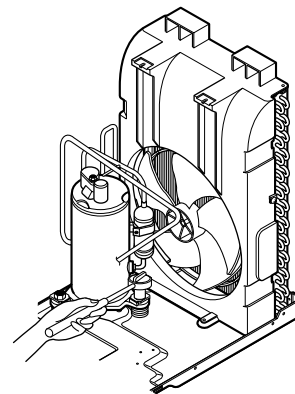

Figure 10

2.3.3 CAPACITOR

1. Remove the cabinet. (Refer to section 2.1.2)
2. Remove the screw and the clamp which fasten the capacitor.
3. Disconnect all the leads of capacitor terminals.
4. Re-install the components by referring to the removal procedure, above. (See Figure 11)

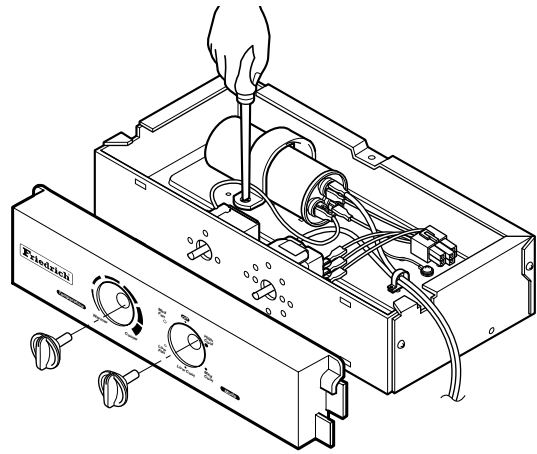

Figure 11

2.3.4 POWER CORD

1. Remove the cabinet. (Refer to section 2.1.2)
2. Disconnect the grounding screw from the control box.
3. Disconnect the 2 receptacles.
4. Remove a screw which fastens the cord clip. (See Figure 12)
5. Remove the power cord.
6. Re-install the component by referring to the removal procedure, above. (Use only one ground-marked hole \oplus for ground connection.)
7. If the supply cord of this appliance is damaged, it must be replaced by the same cord that can be obtained from an authorized parts dealer.

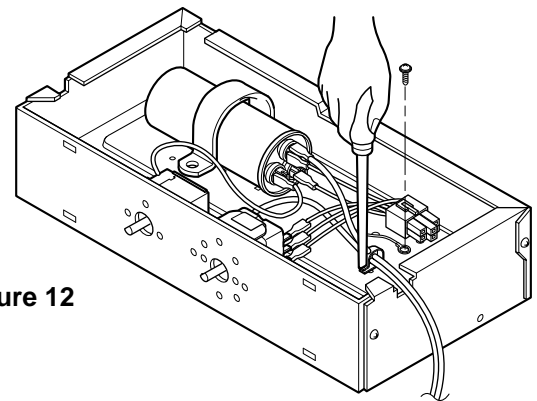

Figure 12

2.3.5 THERMOSTAT

1. Remove the cabinet. (Refer to section 2.1.2)
2. Remove the 2 screws which fasten the thermostat.
3. Disconnect 2 leads of thermostat terminals.
4. Remove the thermostat.
5. Re-install the components by referring to the above removal procedure. (See Figure 13)

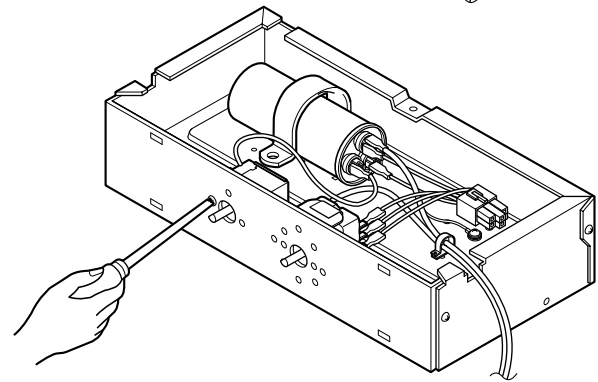

Figure 13

2.3.6 ROTARY SWITCH

1. Remove the cabinet. (Refer to section 2.1.2)
2. Remove the 2 screws which fasten the rotary switch.
3. Disconnect all the leads of the rotary switch terminals.
4. Remove the rotary switch.
5. Re-install the components by referring to the above removal procedure. (See Figure 14)

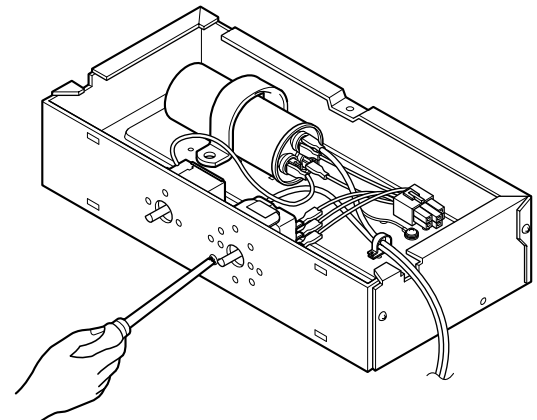

Figure 14

2.3.7 MOTOR

1. Remove the cabinet. (Refer to section 2.1.2)
2. Remove the turbo fan. (Refer to section 2.2.1)
3. Remove the fan. (Refer to section 2.2.2)
4. Remove the 4 screws which fasten the motor from the Motor Mount. (See Figure 15)
5. Remove the motor.
6. Re-install the components by referring to the removal procedure, above.(See Figure 15)

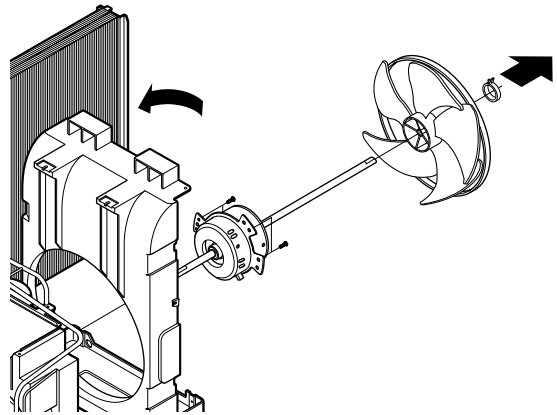

Figure 15

2.4 REFRIGERATING CYCLE

2.4.1 CONDENSER

CAUTION

Discharge the refrigerant system using a Freon™ Recovery System. If there is no valve to attach the recovery system to install one (such as a WATCO A-1) before venting the Freon™. Leave the valve in place after servicing the system.

1. Remove the cabinet. (Refer to section 2.1.2)
2. Remove the 4 screws which fasten the brace.
3. Remove the 4 screws which fasten the condenser and shroud. (See Figure 16)
4. Remove the 2 screws which fasten the condenser and base pan.
5. After discharging the refrigerant completely, unbrazed the interconnecting tube at the condenser connections.
6. Remove the condenser.
7. Re-install the components by referring to notes on p10. (See Figure 16)

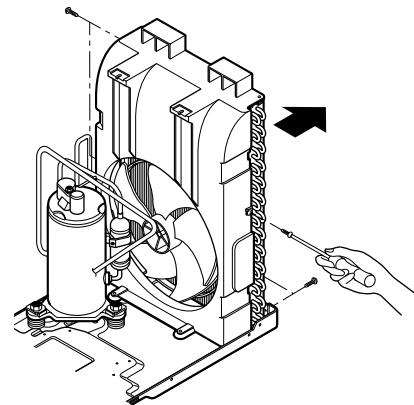

Figure 16

2.4.2 EVAPORATOR

1. Remove the cabinet. (Refer to section 2.1.2)
2. Remove the control box.(Refer to section 2.1.3)
3. Remove the upper air guide. (Refer to section 2.2.1)
4. Remove the 2 screws which fasten the evaporator to the lower air guide.
5. Carefully move the evaporator sideways. (Refer to section 2.2.1)
6. After discharging the refrigerant completely, unbrazed the interconnecting tube at the evaporator connections.
7. Remove the evaporator.
8. Re-install the components by referring to notes on page 10. (See Figure 17)

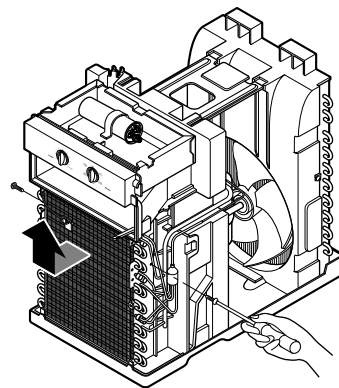

Figure 17

2.4.3 CAPILLARY TUBE

1. Remove the cabinet. (Refer to section 2.1.2)
2. After discharging the refrigerant completely, unbraid the interconnecting tube at the capillary tube. (see caution on previous page)
3. Remove the capillary tube.
4. Re-install the components by referring to notes on page 11.

NOTES

— Replacement of the refrigerant.

1. When replacing the refrigerant, be sure to Discharge the refrigerant system using a Freon™ recovery System.
If there is no valve to attach the recovery system to, install one (such as a WATCO A-1) before venting the Freon™. Leave the valve in place after servicing the system.
 2. After discharging the unit completely, remove the desired component, and unbraid the pinch-off tubes.
 3. Solder service valves into the pinch-off tube ports, leaving the valves open.
 4. Solder the pinch-off tubes with Service valves.
 5. Evacuate as follows.
 - 1) Connect the vacuum pump, as illustrated figure 18A, on page 11.
 - 2) Start the vacuum pump and slowly open manifold valves A and B with two full turns counterclockwise and leave the valves open. The vacuum pump is now pulling through valves A and B up to valve C by means of the manifold and entire system.
 6. Recharge as follows :
 - 1) Refrigeration cycle systems are charged from the High-side. If the total charge cannot be put in the High-side, the balance will be put in the suction line through the access valve which you installed as the system was opened.
 - 2) Connect the charging cylinder as shown in figure 18B, on page 11.
With valve C open, discharge the hose at the manifold connection.
 - 3) Open valve A and allow the proper charge to enter the system. Valve B must remain closed.
 - 4) If more charge is required, the high-side will not take it. Close valve A.
 - 5) With the unit running, open valve B and add the balance of the charge.
 - a. Do not add the liquid refrigerant to the Low-side.
 - b. Watch the Low-side gauge; allow pressure to rise to 30 lbs.
 - c. Turn off valve B and allow pressure to drop.
 - d. Repeat steps b. and c. until the balance of the charge is in the system.
 - 6) When satisfied that the unit is operating correctly, use the pinch-off tool with the unit still running and clamp on to the pinch-off tube. Using a tube cutter, cut the pinch-off tube about 2" from the top of the pinch-off tool. Use sil-fos solder and solder pinch-off tube closed. Turn off the unit, allow it to set for a while, and then test the leakage of the pinch-off connection.
- 3) Operate the vacuum pump for 20 to 30 minutes, until 600 microns of vacuum is obtained. Close valves A and B, and observe vacuum gauge for a few minutes. A rise in pressure would indicate a possible leak or moisture remaining in the system. With valves A and B closed, stop the vacuum pump.
 - 4) Remove the hose from the vacuum pump and place it on the charging cylinder. See figure 18B, on page 11.
Open valve C.
Discharge the line at the manifold connection.
 - 5) The system is now ready for final charging.

CAUTION

If high vacuum equipment is used, adjust valves A and B so they are opened only slightly for a few minutes, then open slowly with the two full turns counterclockwise. This will keep oil from foaming and being drawn into the vacuum pump.

Equipment needed: Vacuum pump, Charging cylinder, Manifold gauge, Brazing equipment. Pinch-off tool capable of making a vapor-proof seal, Leak detector, Tubing cutter, Hand Tools to remove components, Service valve.

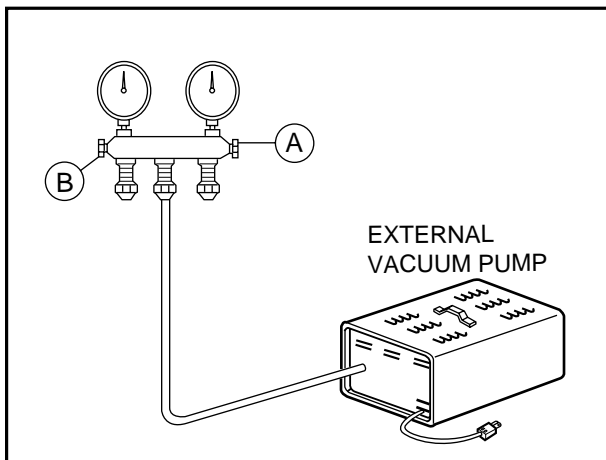
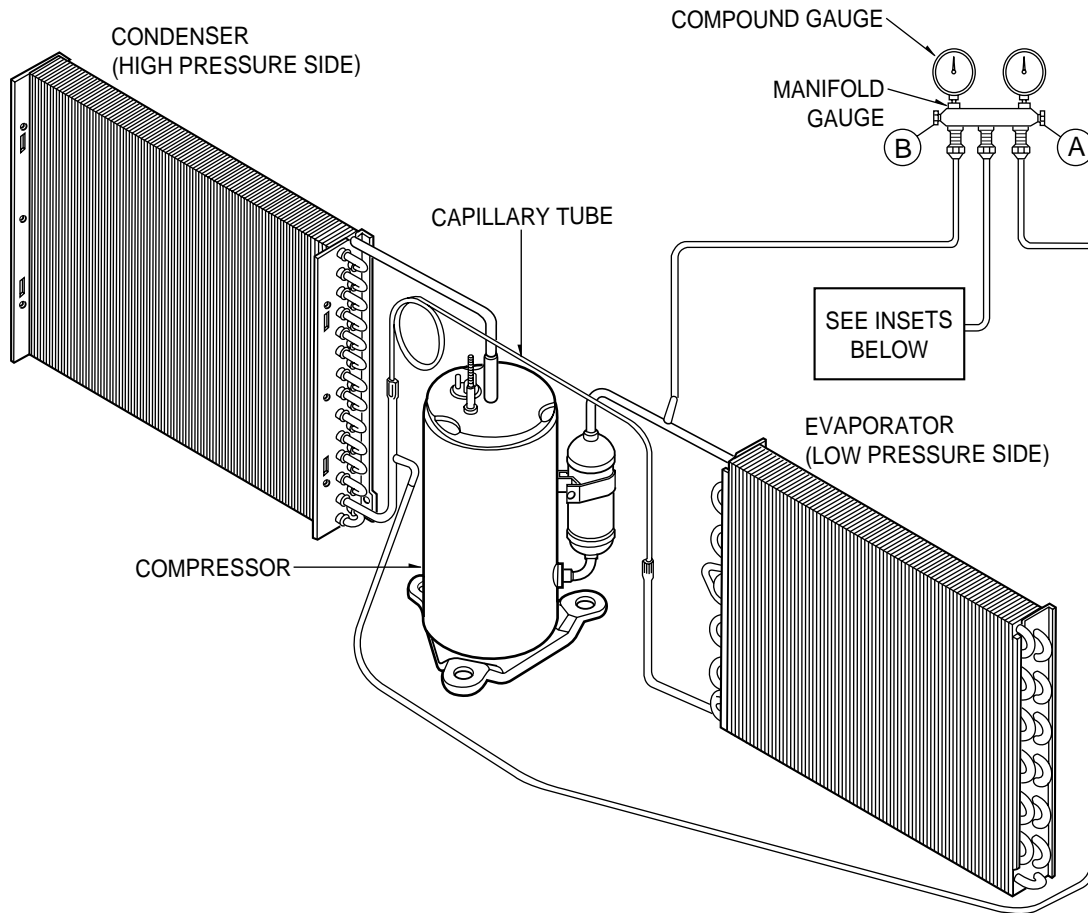

Figure 18A-Pulling Vacuum

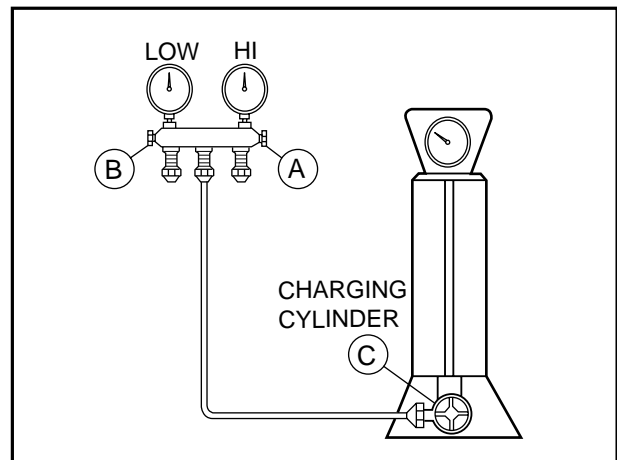

Figure 18B-Charging

3. INSTALLATION

3.1 HOW TO INSTALL THE UNIT

1. To avoid vibration and noise, make sure the unit is installed securely and firmly.
2. Install the unit where the sunlight does not shine directly on the unit.
If the unit receives direct sunlight, build an awning to shade the cabinet.
3. There should be no obstacle, like a fence, within 20" which might restrict heat radiation from the condenser.
4. To prevent reducing performance, install the unit so that louvers of the cabinet are not blocked.
5. Install the unit with a slight downward slope towards the outside (about 1/4"), to ensure that all condensate drains outside.
6. Install the unit with its bottom portion 30~60" above the interior floor level.
7. Stuff the foam gasket between the top of the unit and the wall to prevent air and insects from getting into the room.
8. The power cord must be connected to an independent circuit. The green wire must be grounded.
9. Connect the drain tube to the base pan hole in the rear side if you need to run a drain hose.(consult a dealer).
Plastic hose or equivalent may be connected to the drain tube.

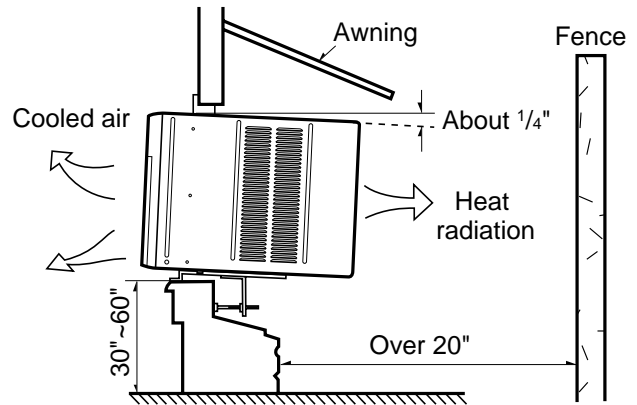

Figure 19

3.2 CHECKING INSTALLATION

The setting conditions must be checked prior to initial start up.

The items mentioned below are important check points to review when the installation is complete.

1. A grounding wire (Green or Green and Yellow) is provided in the power cord. The green wire must be grounded.
2. Connect to a single-outlet 15A circuit.
3. To avoid vibration or noise, make sure the air conditioner is securely installed.
4. Avoid placing furniture or draperies in front of the air inlet and outlet.

3.3. HOW TO DRAIN (When using drain pipe)

The air conditioner must be installed with a slight tilt towards the outside for proper water drainage.

On exceptionally hot and humid days the air conditioner may overflow condensed water to the outside.

If the air conditioner is used in a high humidity zone, exchange the ① DRAIN CAP for the ② DRAIN PIPE.(See Figure 20, Figure 21)

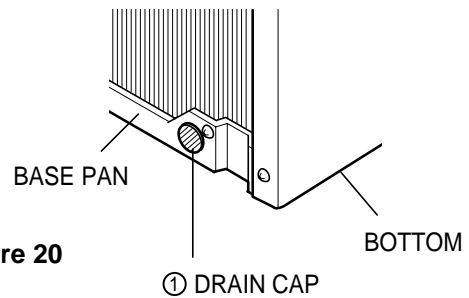

Figure 20

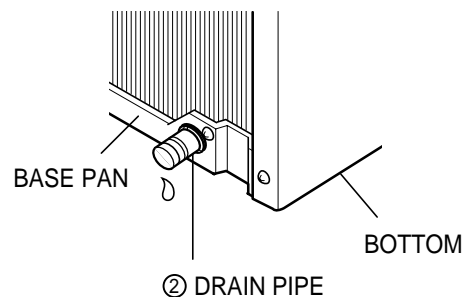
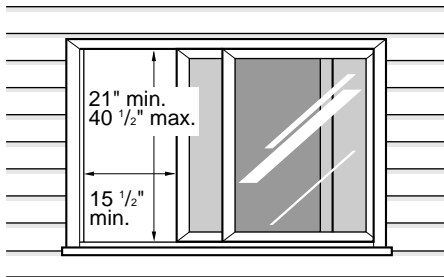

Figure 21

3.4 WINDOW REQUIREMENTS

1. These instructions are for a horizontal sliding or a casement window.
2. The electrical outlet must be within reach of the power cord.

For installation in a casement window, the window frame assembly and the side of the building must be adequate to support the weight of the air conditioner.



Horizontal sliding window

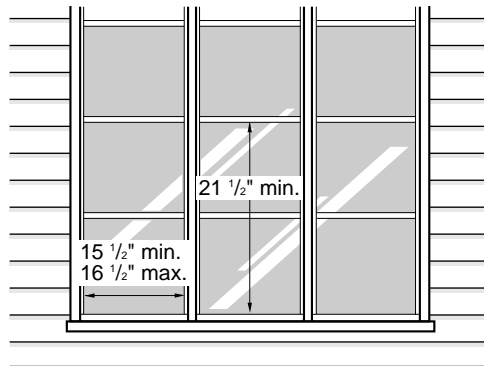

Casement window

3.5 INSTALLATION KIT CONTENTS

Bolt (2)	Nut (2)	Washer (2)	Type A (9)	Type B (3)	Type C (8)

3.6 HORIZONTAL SLIDING WINDOW INSTALLATION

1. Loosely attach the support bracket to the bottom of bracket using bolts, washers, and nuts. Attach the leveling bolt and nut. (See Figure 22)

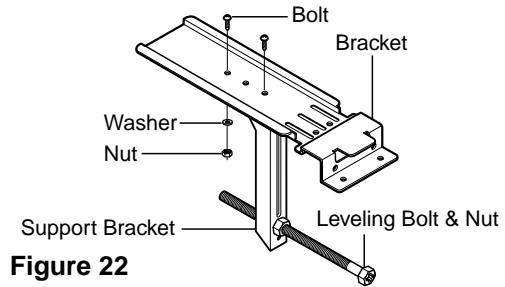

Figure 22

2. Remove protective backing from window track seal and apply seal to window track. (See Figure 23)

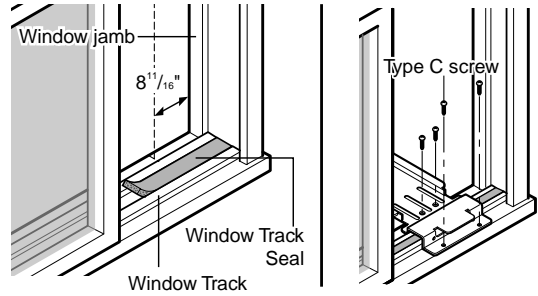

Figure 23

3. Measure and lightly mark a line 8-1/4" from window jamb. Center the support bracket assembly on the window track and fasten with 4-type C screws. (See Figure 23)

4. Put the support bracket against the outside wall and tighten the bolts on top of the bracket. Adjust the leveling bolt so that the air conditioner will be installed with a very slight tilt (about 1/4") downward toward the outside for proper drainage. Tighten the nut. (See Figure 24)

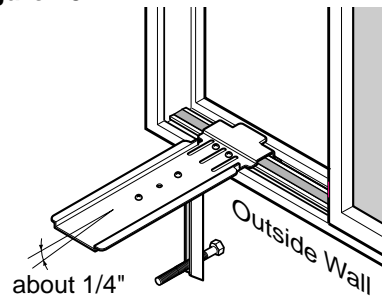

Figure 24

NOTE: DO NOT drill a hole in the bottom of the base pan. The air conditioner is designed to operate with the bottom of the base pan approximately half-full of water.

5. Fasten side guides to the sides of the air conditioner using 3-type A screws per guide. start with first screw at middle of guide. (See Figure 25)

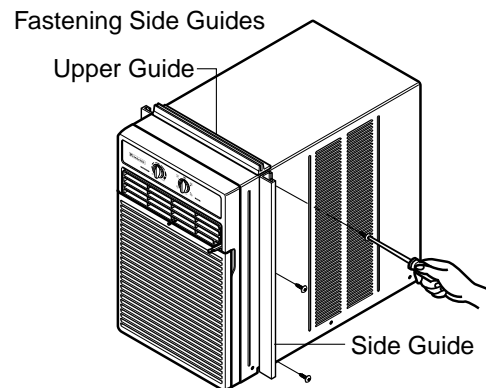

Figure 25

6. Fasten upper guide on the top of the air conditioner using 3-type A screws. (See Figure 25)

7. Measure height of window opening from top of bracket assembly as shown Fig. 26. Subtract 20-3/4". Mark this measurement on curtain and cut the curtain. (See Figure 26)

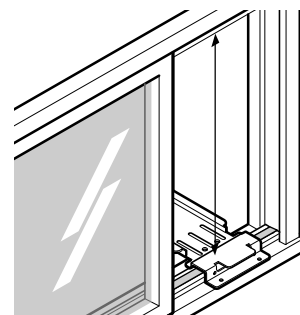

Figure 26

8. Slide curtain into curtain frame. Slide curtain frame assembly into side guides of the air conditioner cabinet. Make sure curtain is firmly enclosed on all sides by the frame. (See Figure 27)

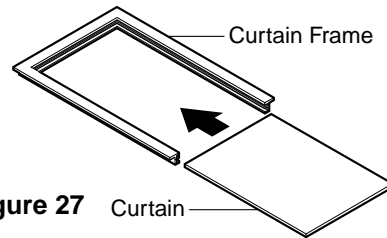

Figure 27 Curtain

9. Cut side guide seal into 2 equal lengths. Remove protective backing and apply it to the rear side of cabinet side guides, starting just below curtain frame assembly. Pinch off excess length so seal is even with the bottom of side guide. (See Figure 28)

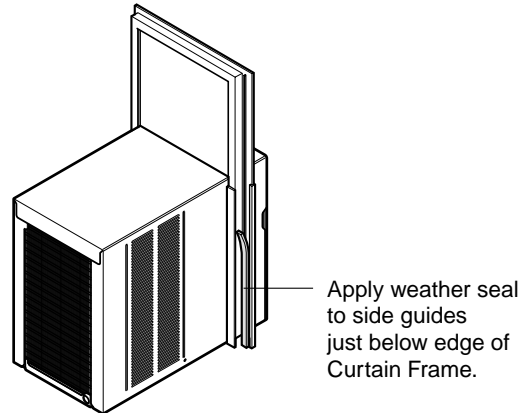

Figure 28

10. Place air conditioner in window opening. It should sit on bracket assembly so that curtain frame and cabinet side guides are against top and side window jambs. Mate front of bracket with base guide attached to the bottom of base pan.

11. Drill 1/8 inch holes in window track through the existing holes on base guide. Screw 4-type C screws through the holes. (See Figure 29)

12. If this is a casement window installation, proceed to casement window installation. If not, slide inner window sash firmly against side of the cabinet.

13. Drill 1/8 inch hole in window jamb to align with the existing holes in the curtain frame. Attach curtain frame to window frame with 2-type B screws. (See Figure 29)

NOTE: Check all seals and plug any remaining air gaps with a suitable weatherproof caulk.

14. If this is a casement window installation, proceed to casement window installation. If not, stuff the foam seal strip between the vertical sash and the window glass. (See Figure 30)

15. Attach the window locking bracket with a type B screw. (See Figure 30)

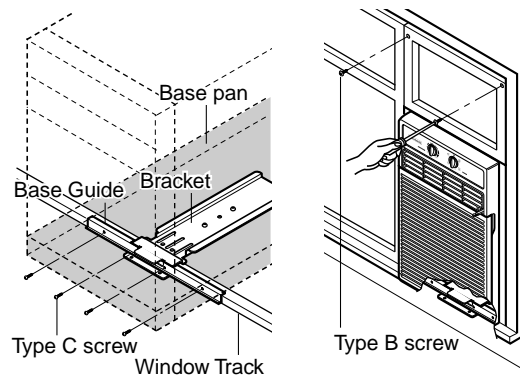

Figure 29

3.7 CASEMENT WINDOW INSTALLATION

- Installation procedure is the same as that described in steps 1 through 11 and step 13 of the horizontal sliding window installation.
- If the window opening is wider than 15-3/4" you will need to install a filler panel. Make this panel from 3/4 inch thick wood and run it the full length of the window. Attach it securely to the window frame and paint it to protect it from the weather.
- Since styles and sizes of casement windows vary widely, it is advisable to have the air conditioner installed by someone skilled in this type of installation.

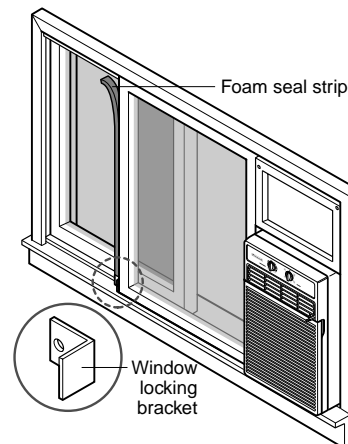
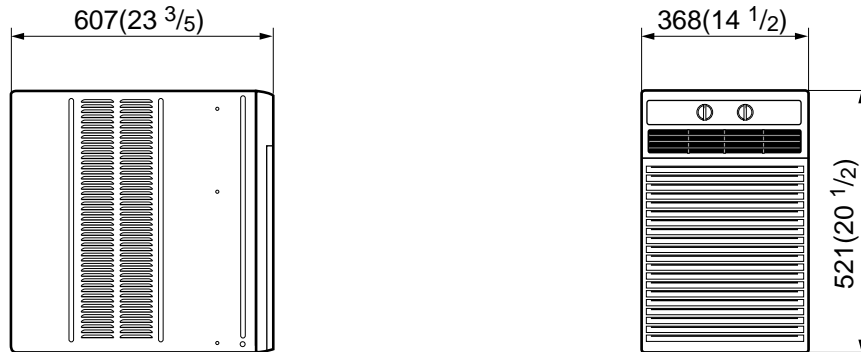

Figure 30

4. TROUBLESHOOTING GUIDE

4.1 OUTSIDE DIMENSIONS

Unit: mm(inchs)



4.2 PIPING SYSTEM

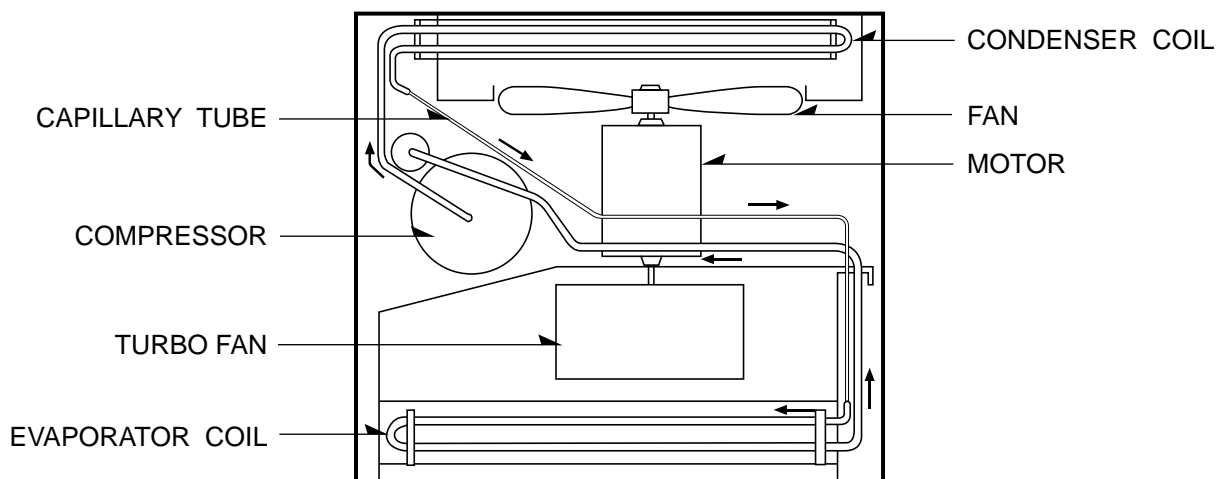

Following is a brief description of the important components and their functions in the refrigeration system. Refer to Fig. 31 to follow the refrigeration cycle and the flow of the refrigerant in the cooling cycle.

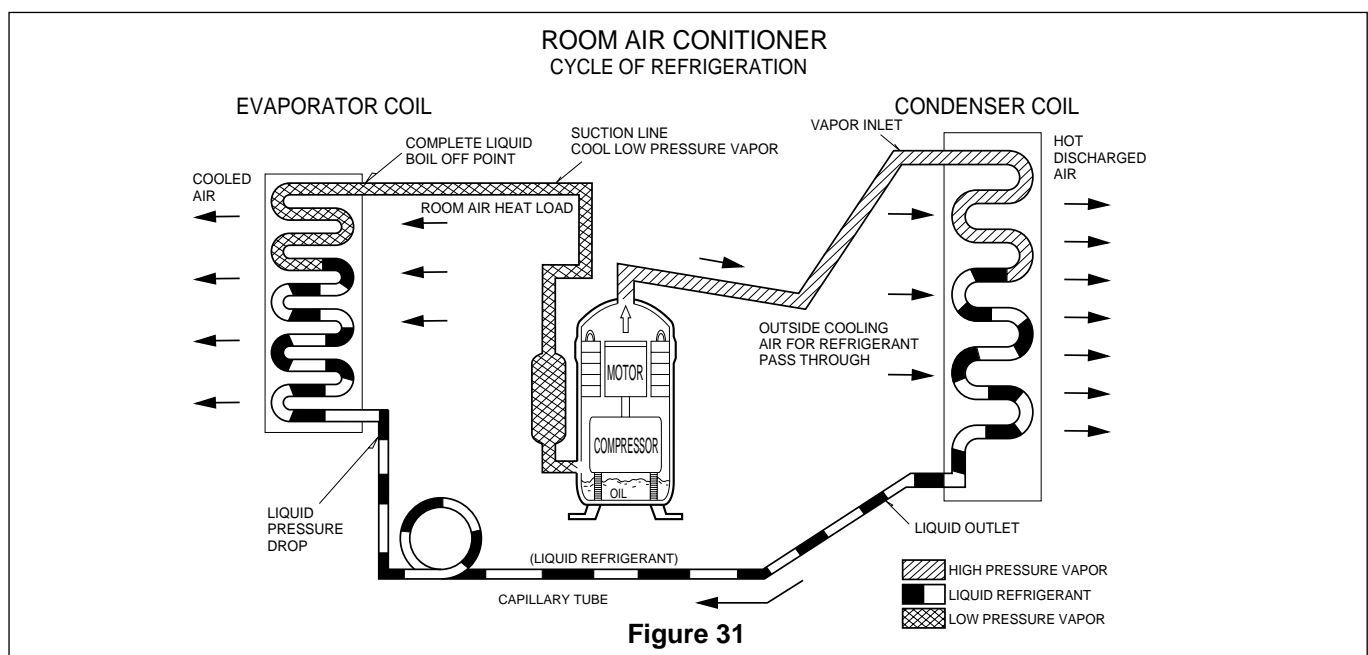

Figure 31

4.3 TROUBLESHOOTING GUIDE

In general, possible trouble is classified in two kinds.

The one is called Starting Failure which is caused from an electrical defect, and the other is ineffective Air Conditioning caused by a defect in the refrigeration circuit and/or improper application.

Unit runs but poor cooling.

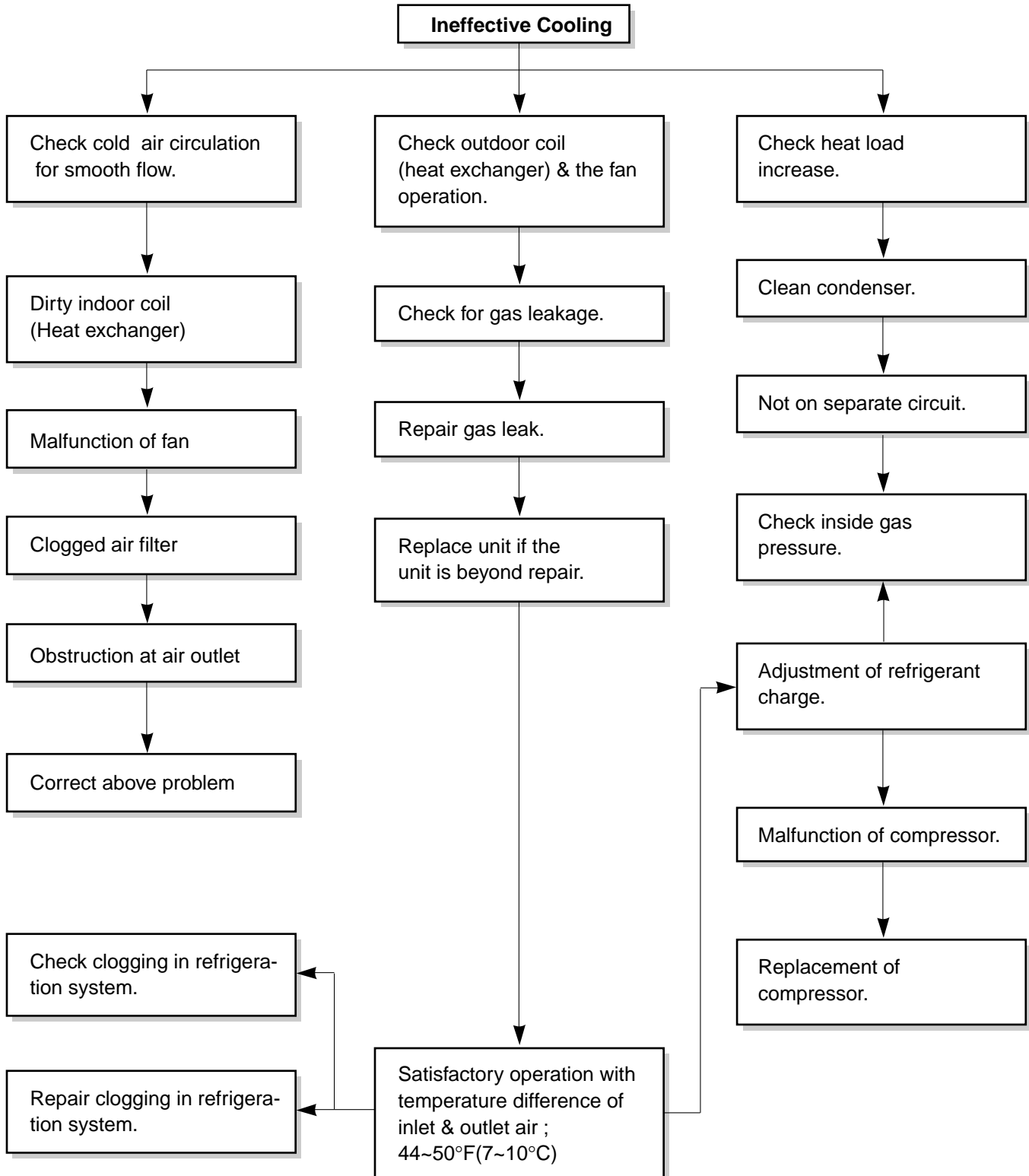

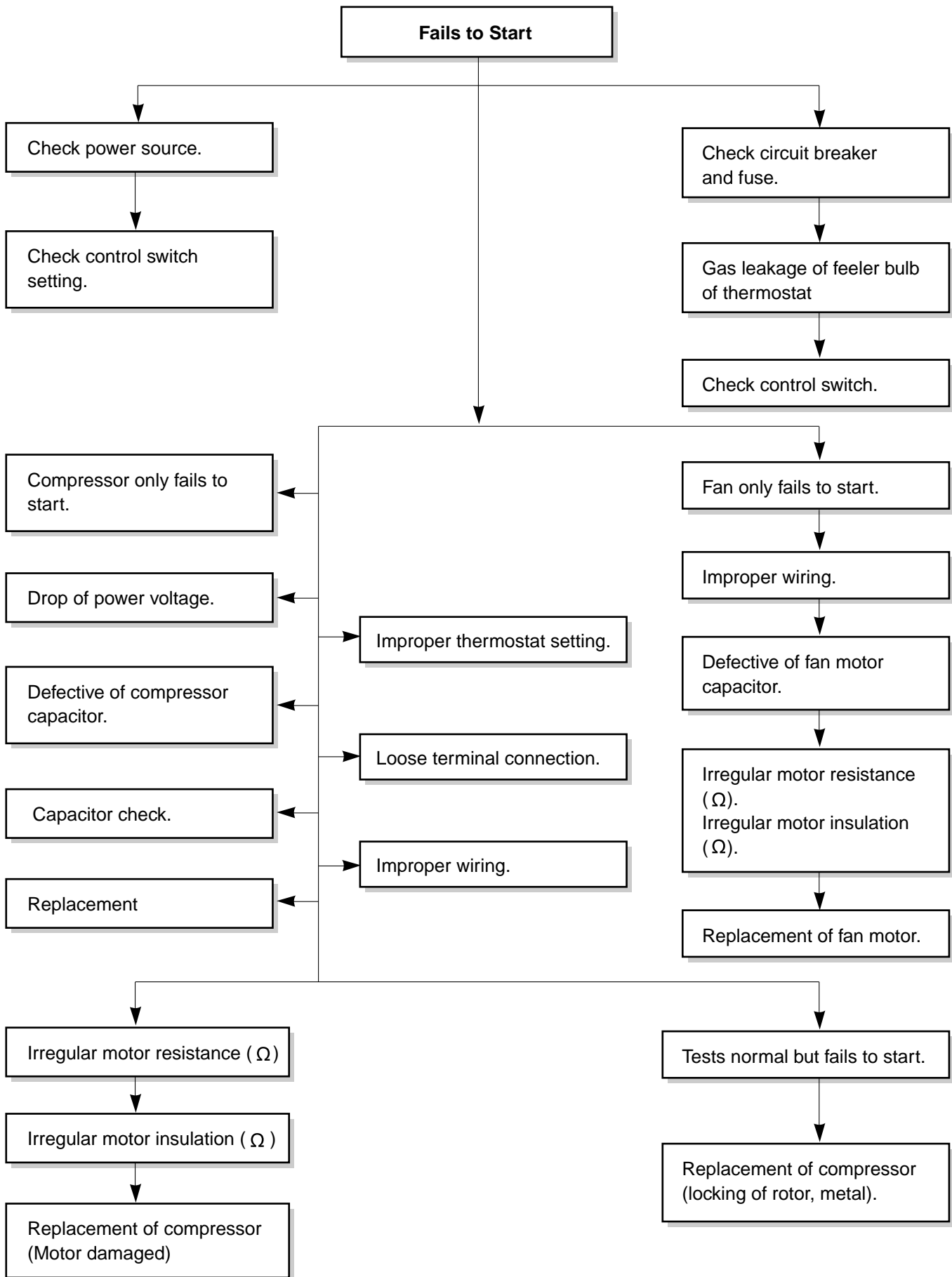

ROOM AIR CONDITIONER VOLTAGE LIMITS

NAME PLATE RATING	MINIMUM	MAXIMUM
115V ±10%	103.5V	126.5V

COMPLAINT	CAUSE	REMEDY
Fan motor will not run	No power	Check voltage at outlet. Correct if none.
	Power supply cord	Check voltage to rotary switch. If none, check power supply cord. Replace cord if circuit is open.
	Rotary switch	Check switch continuity. Refer to wiring diagram for terminal identification. Replace switch if defective.
	Wire disconnected or connection loose	Connect wire. Refer to wiring diagram for terminal identification. Repair or replace loose terminal.
	Capacitor (Discharge capacitor before testing.)	Test capacitor. Replace if not within ±10% of manufacturer's rating. Replace if shorted, open, or damaged.
	Will not rotate	Fan blade hitting shroud or blower wheel hitting scroll. Realign assembly. Units using slinger ring for condenser fan must have $\frac{1}{4}$ to $\frac{5}{16}$ inch clearance to the base. If it hits the base, shim up the bottom of the fan motor with mounting screw(s). Check fan motor bearings; if motor shaft will not rotate, replace the motor.
Fan motor runs intermittently	Revolves on overload.	Check voltage. If not within limits, call an electrician. Test capacitor. Check bearings. Does the fan blade rotate freely? If not, replace fan motor. Pay attention to any change from high speed to low speed. If the speed does not change, replace the motor.
Fan motor noise	Fan	If cracked, out of balance, or partially missing, replace it.
	Blower	If cracked, out of balance, or partially missing, replace it.
	Loose clamper	Tighten it.
	Worn bearings	If knocking sounds continue when running or loose, replace the motor. If the motor hums or noise appears to be internal while running, replace motor.
Compressor will not run, but fan motor runs	Voltage	Check voltage. If not within limits, call an electrician.
	Wiring	Check the wire connections, if loose, repair or replace the terminal. If wires are off, refer to wiring diagram for identification, and replace. Check wire locations. If not per wiring diagram, correct.
	Rotary	Check for continuity, refer to the wiring diagram for terminal identification. Replace the switch if circuit is open.

COMPLAINT	CAUSE	REMEDY
Compressor will not run, but fan motor runs.	Thermostat	Check the position of knob. If not at the coldest setting, advance the knob to this setting and restart unit. Check continuity of the thermostat. Replace thermostat if circuit is open.
	Capacitor (Discharge capacitor before servicing.)	Check the capacitor. Replace if not within $\pm 10\%$ of manufacturer's rating. Replace if shorted, open, or damaged.
	Compressor	Check the compressor for open circuit or ground. If open or grounded, replace the compressor.
	Overload	Check the compressor overload, if externally mounted. Replace if open. (If the compressor temperature is high, remove the overload, cool it, and retest.)
Compressor cycles on overload.	Voltage	Check the voltage. If not within limits, call an electrician.
	Overload	Check overload, if externally mounted. Replace if open. (If the compressor temperature is high, remove the overload, cool, and retest.)
Compressor cycles on overload.	Fan motor	If not running, determine the cause. Replace if required.
	Condenser air flow restriction	Remove the cabinet. inspect the interior surface of the condenser; if restricted, clean carefully with a vacuum cleaner (do not damage fins) or brush. Clean the interior base before reassembling.
	Condenser fins (damaged)	If condenser fins are closed over a large area on the coil surface, head pressures will increase, causing the compressor to overload. Straighten the fins or replace the coil.
Compressor cycles on overload.	Capacitor	Test capacitor.
	Wiring	Check the terminals. If loose, repair or replace.
	Refrigeration System	Check the system for a restriction.
Insufficient cooling or heating	Air filter	If restricted, clean or replace.
	Exhaust damper door	Close if open.
	Unit undersized	Determine if the unit is properly sized for the area to be cooled.
Excessive noise	Blower or fan	Check the set screw or clamp. If loose or missing, correct. If the blower or fan is hitting the air guide, rearrange the air handling parts.
	Copper tubing	Remove the cabinet carefully and rearrange tubing so that it doesn't contact the cabinet, compressor, shroud, and barrier.

5. SCHEMATIC DIAGRAM

5.1 CIRCUIT DIAGRAM

■ MODEL : SV10A10A / SV1210A

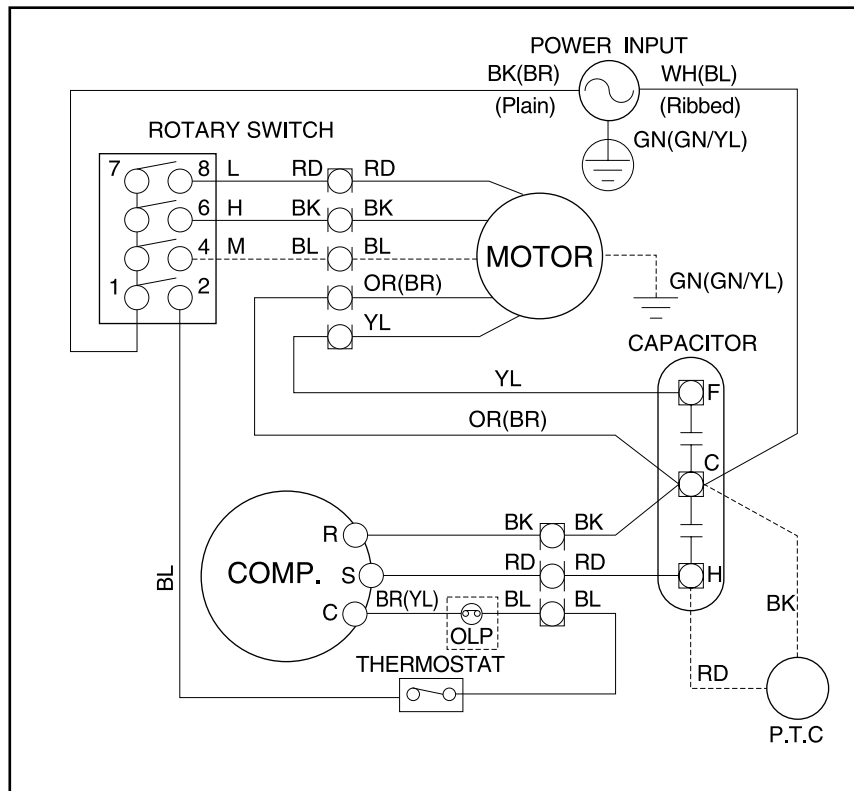

S: Service Parts
N: Non Service Parts

LOCATION NO.	DESCRIPTION	PART NO.		Q'TY PER SET	RE-MARKS
		SV10A10A	SV12A10A		
1	POWER CORD	-	-	1	S
2	ROTARY SWITCH	67300501		1	S
3	FAN MOTOR	67303015		1	S
4	CAPACITOR	67300709	-	1	S
5	THERMOSTAT	67300403		1	S
6	COMPRESSOR	67301614	67301615	1	S

5.2 CIRCUIT DIAGRAM

■ MODEL : SV08A10A

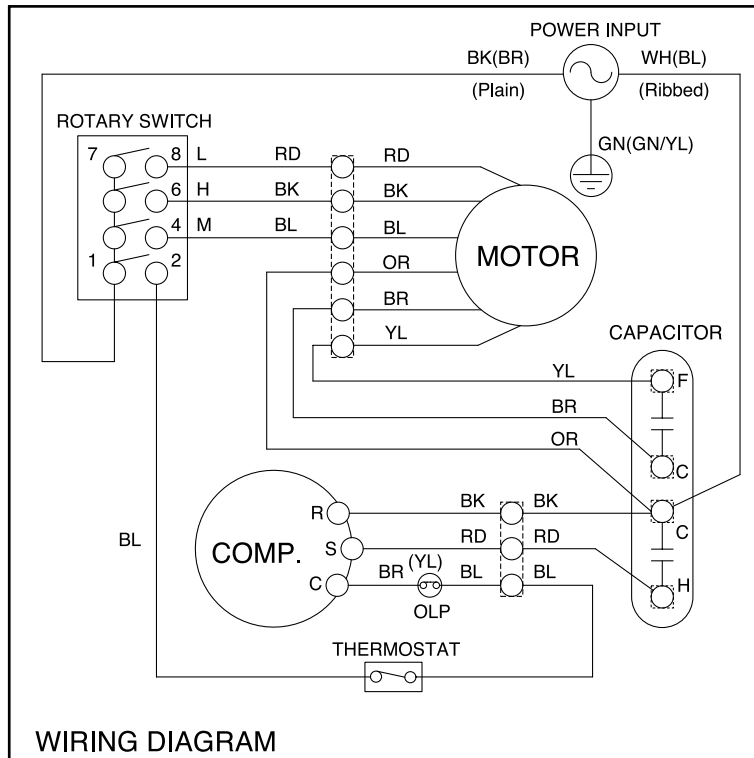

S: Service Parts
N: Non Service Parts

LOCATION NO.	DESCRIPTION	PART NO.	Q'TY PER SET	RE-MARKS
		SV08A10A		
1	POWER CORD	67300005	1	S
2	ROTARY SWITCH	67300501	1	S
3	FAN MOTOR	67303014	1	S
4	CAPACITOR	67300712	1	S
5	THERMOSTAT	67300403	1	S
6	COMPRESSOR	67301612	1	S

6. EXPLODED VIEW

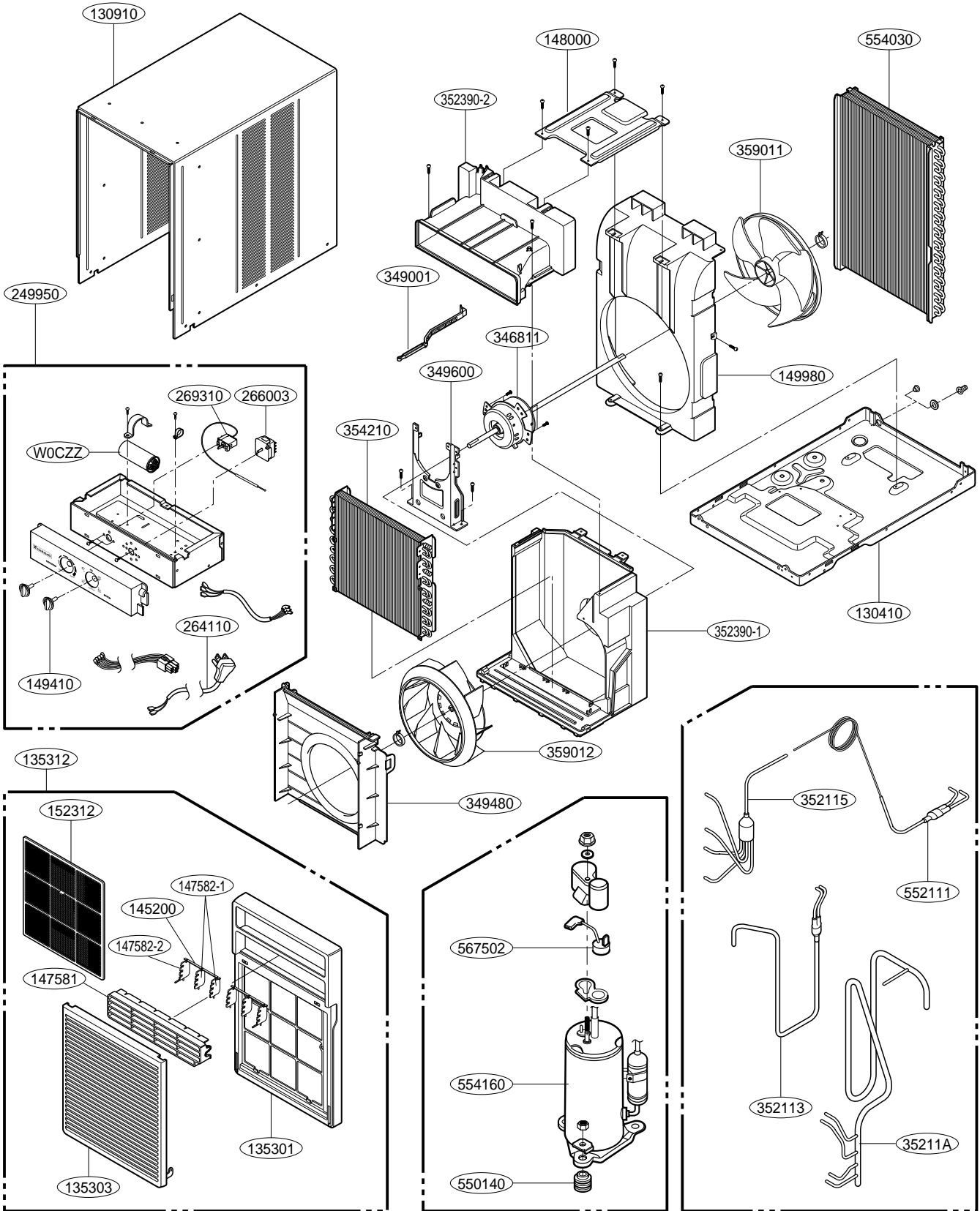

7. REPLACEMENT PARTS LIST

■ MODEL : SV08A10A, SV10A10A, SV12A10A

LOCATION No.	DESCRIPTION	P/No			REMARK
		SV08A10A	SV10A10A	SV12A10A	
130410	BASE ASSEMBLY, SINGLE	67302911	67302910		R
130910	CABINET ASSEMBLY, SINGLE	67303706			R
135303	GRILLE INLET	67306105			R
135312	GRILLE ASSEMBLY, FRONT	67306007			R
147581	VANE, HORIZONTAL	67306204			R
147582	VANE, VERTICAL	67306254	67306255		R
148000	BRACE	67303904			R
149410	KNOB ASSEMBLY	67304104			R
149980	SHROUD ASSEMBLY	67303109			R
152312	FILTER ASSEMBLY	67304305			R
264110	POWER CORD ASSEMBLY	67300005	67300006	67300007	R
266003	SWITCH, ROTARY	67300501			R
269310	THERMOSTAT ASSEMBLY	67300403			R
346811	MOTOR ASSEMBLY, SINGLE	67303014	67303015		R
349001	DAMPER	67303505			R
349480	ORIFICE	67303407			R
349600	MOUNT, MOTOR	67303608			R
352380	AIR GUIDE-LOWER ASSEMBLY	67302715			R
352390	AIR GUIDE ASSEMBLY-UPPER	67302714			R
354210	EVAPORATOR ASSEMBLY	67302411	67302412		R
359011	FAN ASSEMBLY AXIAL	67303206			R
359012	FAN ASSEMBLY, TURBO	67302610			R
550140	ISOLATOR, COMP	67301900			R
552111	TUBE ASSEMBLY, CAPILLARY	67302108	67302109	67302110	R
554030	CONDENSER ASSEMBLY	67303310	67303311		R
554160	COMPRESSOR	67301612	67301614	67301615	R
567502	O.L.P	67301410	67301409	67301407	R
W0CZZ	CAPACITOR, DRAWING	67300712	67300709	67300713	R
731273	INSTALLATION KIT	67306306			
237900	WINDOW, DISPLAY	67308101			R
132100	FRAME, PANEL	67308100			R
749740-1	GUIDE, UPPER	67304004			R
749740-2	GUIDE, FRAME	67306402			R
W4810-1	BRACKET	67303905			R
W4810	SUPPORT, BRACKET	67303906			

MEMO

MEMO

Use Factory Certified Parts...



FRIEDRICH AIR CONDITIONING CO.
Visit our web site at www.friedrich.com

Post Office Box 1540 • 4200 N. Pan Am Expressway • San Antonio, Texas 78295-1540
• (210) 357-4400 • FAX (210) 357-4480

P/NO.: 3828A20190X

Printed in the U.S.A

SV08 / SV10 / SV12 (01/05)