

SERVICE DATA SHEET

P/N: 808463501 Rev.B
 Artwork: 808463501 Rev.002

FRIGIDAIRE
 Electronic Series

COLOR CODE

BK.....Black
 BU.....Blue
 PK.....Pink
 R.....Red
 Viol.....Violet
 W.....White
 Y-BK.....Yellow/BK
 R-Y.....Red/Yellow
 BK-W.....Black/White
 R-W.....Red/White

OPERATION

The dishwasher responds to user inputs only when its door is open.
 To select a new cycle or option: Press to select desired cycle and/or option (indicator lights will change).
 To delay start : Press DELAY START repeatedly until the desired delay time is displayed.
 For controls lock: Press and hold DELAY START for 3 seconds (its LED will illuminate when lock is set)
 To start: Press START/CANCEL and close the door.

DISPLAY CODES (READOUT)

PF Flashes when a Power Failure has occurred
 CL Close and latch the door
 Er Switch failure (shorted keypad)
 Th Open/shorted thermistor
 Tu Open/shorted turbidity sensor
 hS Pump rpm error
 Uo Vent stuck open
 uC Vent stuck closed
 uF Vent rpm too low or stopped

DISPLAY CODES (LED)

Delay Displayed when unit is counting down a delay
 Clean Displayed to indicate the cycle is complete
 Sanitize Displayed to indicate sanitization was achieved

This information is intended for use by persons having electrical and mechanical training and a level of knowledge of these subjects generally considered acceptable in the appliance repair trade. Electrolux Home Products North America cannot be responsible, nor assume any liability, for injury or damage of any kind arising from the use of this Service Data Sheet.

WATER/SERVICE TEST

To activate the Water/Service Test, cycle the circuit breaker to put the unit in Power Failure Mode. Simultaneously press "DRY" and START/CANCEL for 3 seconds.

The dishwasher will then step through the test cycle per the chart. If START/CANCEL is pressed during the test the current step is terminated and the test advances to the next cycle step.

Interval Number	Fill Number	Description	Interval Duration Sec.	Motor Speed (rpm)	Water Valve	Circulation Motor	Drain Motor	Heater	Dispenser	Blower	Washing LED	Drying LED	Sanitize LED	Clean LED	Monitored Device	On display upon detection of failure
1	1	Fill/Det. Dispenser	60	0	1	0	0	0	1	0	1	0	0	0	fan damper	uo
2	1	Fill	27	0	1	0	0	0	0	0	1	0	0	0	turbidity	tu
3	1	Wash/Heat/Det.Disp.	45	3400	0	1	0	1	1	0	1	0	0	0	hall sensor	hS
4	1	Pause/Heat	0.4	0	0	0	0	1	0	0	1	0	0	0		
5	1	Wash/Heat	75	2800	0	1	0	1	0	0	0	0	0	0		
6	1	Wash/Heat/Det.Disp.	60	3400	0	1	0	1	1	0	0	0	0	0	thermistor	th
7	1	Drain	90	0	0	0	1	0	0	1	0	0	0	0	fan speed	uF
8	1	Dry	90	0	0	0	0	1	0	1	0	1	0	0	fan damper	uC
9	1	End State		0	0	0	0	0	0	0	0	0	1	1		

Note: End State remains in effect until door is opened

WIRING DIAGRAM

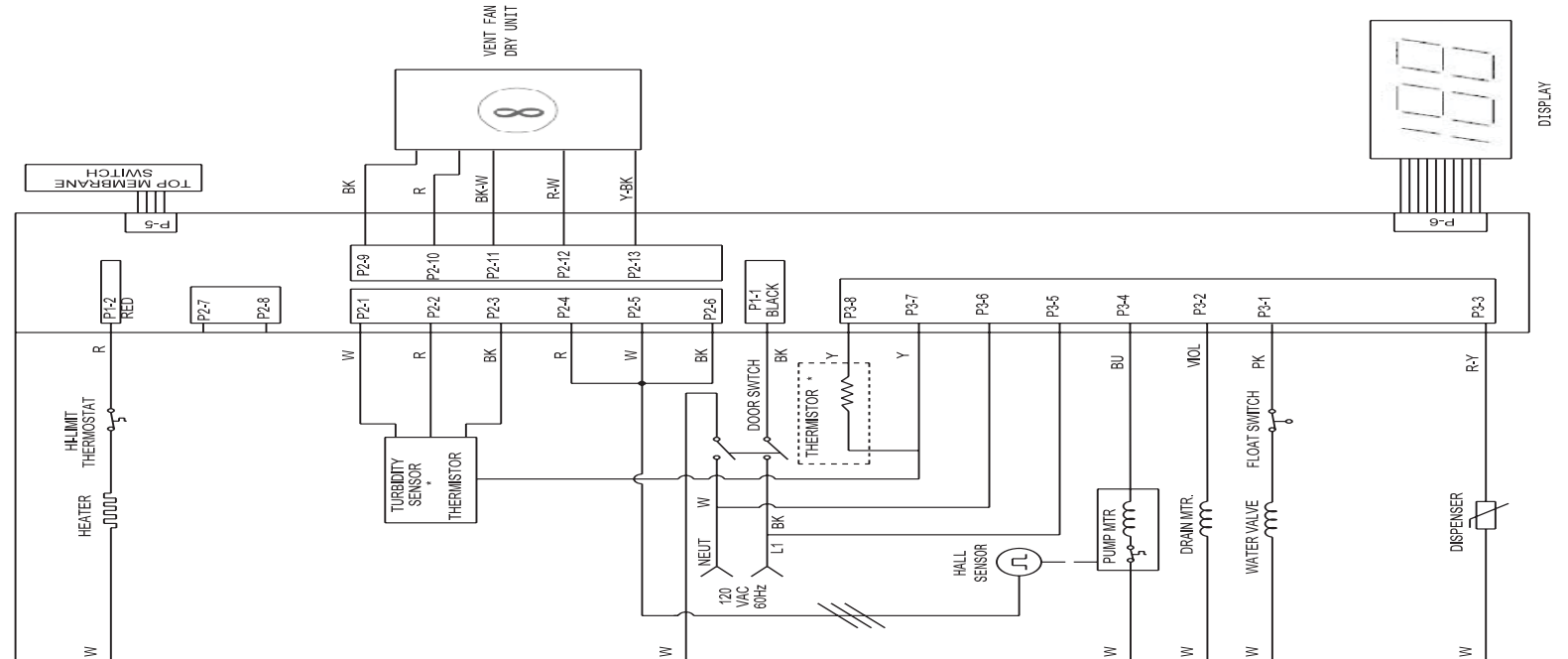

CYCLE SELECTION OPTIONS

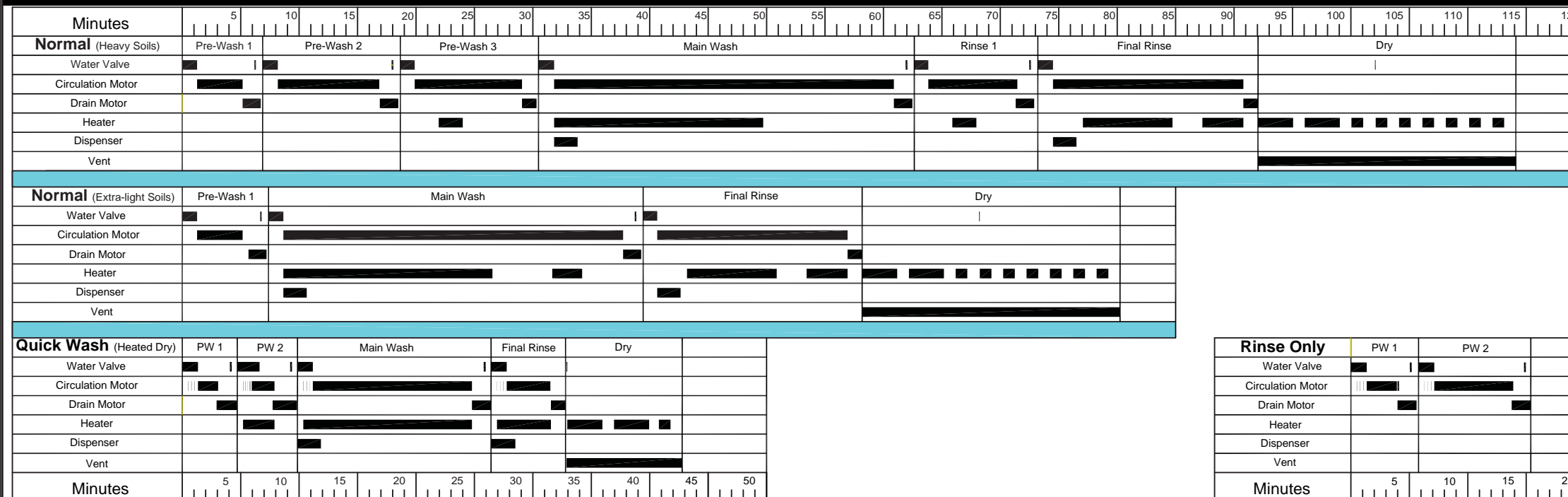

NOTE:

- In all cycles except Rinse Only and Quick Wash the main wash and final rinse may be lengthened when needed to reach optimal wash temperatures.
- If Normal Wash is the first cycle run after applying power the heavy soil response shown here will result. Thereafter, the sensor will be calibrated. Then, the cycle will automatically adjust to the amount of food soil by running only as many of the pre-washes or pre-rinses as appropriate. Normal Wash will run the extra-light soil response shown here when run empty or with dishware having extra-light or no soil are installed.
- In the Quick Wash and Rinse Only cycles it is normal for the circulation pump to pulse during fills .

EXPLODED VIEW OF WASH SYSTEM

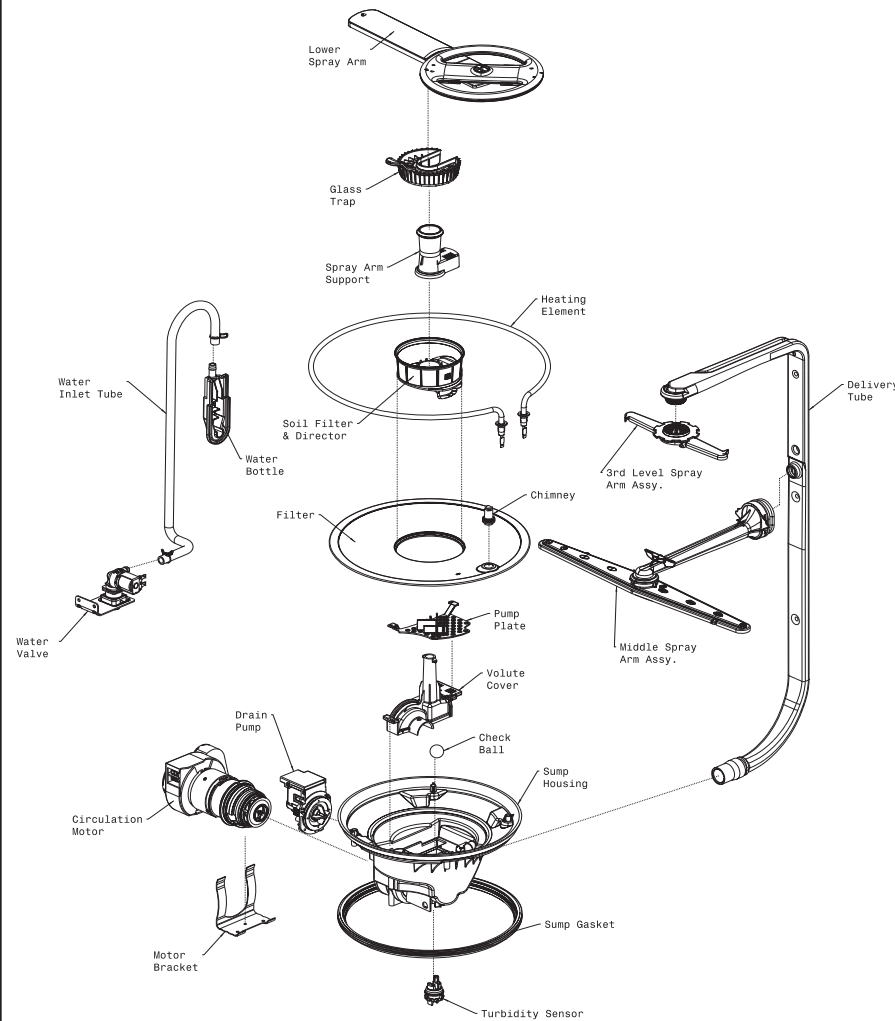

Pump Assembly

The pump assembly is driven by a synchronous motor. Rotation is in the counterclockwise direction at up to 3600 RPM. The motor drives a pump which supplies 100 percent filtered water at a rate of approximately 12 GPM to one spray arm at a time. The spray arm's operation is alternated by small "pauses" of the motor during the wash cycle.

Draining is accomplished by using a small separate synchronous drain pump mounted to the side of the sump. The drain check valve is located at the discharge end of the drain pump. The drain hose is attached by a worm gear clamp to the discharge end of the drain pump.

The drain hose must have a loop at a **minimum height of 32 inches** in order to insure proper drainage.

To remove the main circulation (circ) pump do the following in sequence: Shut off electricity to the dishwasher. Disconnect the wiring harness connections located at the circ pump's motor. Remove the two screws that hold the motor bracket. Slide the motor bracket away from the sump. The motor and pump, now held only by friction against O-rings, can be pulled out of the sump.

Standard Dry Air Flow

The heating element at the bottom of the tub and the vent assembly in the top right rear of the tub are used to dry dishware. During the "dry" portion of the cycle the heater, the solenoid that opens the vent's damper and the vent fan are energized. The vent fan draws in cooler, drier air from outside the tub and pushes it down into the tub. Hot moist air rises to

the duct inlet near the top of the door. At the duct exit near the bottom of the door drier air escapes into the kitchen and the condensed water runs into the drain portion of the dishwasher. Energy from the heating element warms the incoming air and augments the energy stored in the dishware. Together their energy causes the water on the dishware to evaporate.

Detergent and Rinse

The detergent and rinse aid dispenser is a one piece component consisting of a molded detergent cup and a built-in rinse aid dispenser.

The detergent cup has a spring loaded cover and the rinse aid dispenser has a removeable cover.

To re-fill, remove the cap and pour rinse aid in until the level shows above the bottom of the cylindrical opening and the sight gauge changes appearance. If any is spilled wipe it up before starting the cycle. The amount of rinse aid released

can be adjusted by turning the arrow indicator from one, being the least amount, to four, being the greatest amount.

To replace dispenser:

- shut off electricity to dishwasher,
- remove outer door panel assembly,
- disconnect wiring to the actuator,
- remove the six screws,
- replace and reinstall screws,
- rewire actuator.

Tub and Door Seal

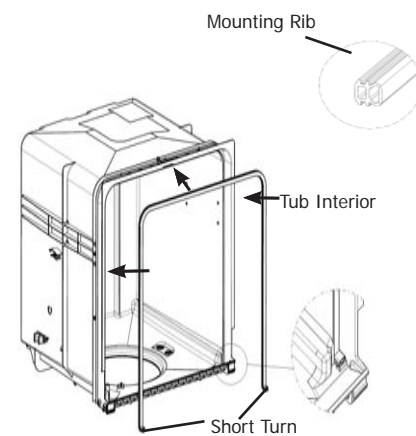

Line up the center mark on the back of the seal with the tub top center and press it into the channel. Move along the channel left and right periodically pressing the seal into place without bunching or stretching it until going around the corners at the top. Next, place the free ends into the channel at the bottom left and right by creating a short turn at the bottom of the tub channel and ensuring the seal extends to the locator ridge at the bottom of the tub (see enlarged portion of the image at left). Then, press the seal periodically into place. Finally slide your fingers over the seal to press it fully in place. When complete a single face of the seal should be visible and flush with the edge of the channel.

Product Specifications

Electrical

Rating.....	120 Volts, 60Hz
Separate Circuit.....	15 amp min.- 20 amp max.
Motor (Amps).....	1.8
Heater Wattage.....	900
Total Amps (load rated).....	10.0
TempAssure.....	140°F±5°F (60°C±3°C) [with outer door in place]
TempBoost.....	145°F±5°F (63°C±3°C) Heated Wash/Heated Rinse
Sanitize.....	150°F±5°F (66°C±3°C)
Hi-Limit Thermostat	200°F (93°C)

Water Supply

Suggested minimum incoming water temperature.....	120
Pressure (PSI) min./max.....	20/120
Connection.....	3/8" NPT or 3/4" Hose Thread
Consumption (Normal Cycle).....	4.9 - 9.7 U.S. gal., 18.5 - 36.7
Water valve flow rate (U.S.GPM).....	83
Water recirculation (U.S. GPM).....	approx. 12
Water fill time.....	87

TROUBLE SHOOTING TIPS

⚠ WARNING

Personal Injury Hazard

Always disconnect the dishwasher from the electrical power source before adjusting or replacing components.

Symptom	Check the Following	Remedy
Dishwasher will not operate when turned on.	<ol style="list-style-type: none"> 1. Fuse (blown or tripped). 2. 120 VAC supply wiring connection faulty. 3. Electronic control board defective. 4. No 12 VAC power to control. 5. Motor (inoperative). 6. Door Switch (open contacts). 7. Door latch not making contact with door switch 8. Touch pad circuit defective. 9. No indicator lamps illuminate when START or OPTIONS are pressed. 	<ol style="list-style-type: none"> 1. Replace fuse or reset breaker. 2. Repair or replace wire fasteners at dishwasher junction box. 3. Replace control board. 4. Replace control board. 5. Replace motor/impeller assembly. 6. Replace latch assembly. 7. Replace latch assembly. 8. Replace console assembly. 9. Replace console assembly.
Motor hums but will not start or run.	<ol style="list-style-type: none"> 1. Motor (bad bearings). 2. Motor stuck due to prolonged non-use. 	<ol style="list-style-type: none"> 1. Replace motor assembly. 2. Rotate motor impeller.
Motor trips out on internal thermal overload protector.	<ol style="list-style-type: none"> 1. Improper voltage. 2. Motor windings shorted. 3. Glass or foreign items in pump. 	<ol style="list-style-type: none"> 1. Check voltage. 2. Replace motor/impeller assembly. 3. Clean and clear blockage.
Dishwasher runs but will not heat.	<ol style="list-style-type: none"> 1. Heater element (open). 2. Electronic control board defective. 3. Wiring or terminal defective. 4. Hi-Limit thermostate defective. 5. Thermistor failure. 	<ol style="list-style-type: none"> 1. Replace heater element. 2. Replace control board. 3. Repair or replace. 4. Replace thermostat. 5. Replace turbidity sensor.
Detergent cover will not latch or open.	<ol style="list-style-type: none"> 1. Latch mechanism defective. 2. Electronic control board defective. 3. Wiring or terminal defective. 4. Broken spring (s). 5. Defective actuator. 	<ol style="list-style-type: none"> 1. Replace dispenser. 2. Replace control board. 3. Repair or replace. 4. Replace dispenser. 5. Replace dispenser.
Dishwasher will not pump out.	<ol style="list-style-type: none"> 1. Drain restricted. 2. Electronic control board defective. 3. Defective drain pump. 4. Blocked impeller. 5. Open windings. 6. Wiring or terminal defective. 	<ol style="list-style-type: none"> 1. Clear restrictions. 2. Replace control board. 3. Replace pump. 4. Check for blockage, clear. 5. Replace pump assembly. 6. Repair or replace.
Dishwasher will not fill with water.	<ol style="list-style-type: none"> 1. Water supply turned off. 2. Defective water inlet fill valve. 3. Check fill valve screen for obstructions. 4. Defective float switch. 5. Electronic control board defective. 6. Wiring or terminal defective. 7. Float stuck in "UP" position. 	<ol style="list-style-type: none"> 1. Turn water supply on. 2. Replace water inlet fill valve. 3. Disassemble and clean screen. 4. Repair or replace. 5. Replace control board. 6. Repair or replace. 7. Clean float.
Dishwasher water siphons out.	<ol style="list-style-type: none"> 1. Drain hose (high) loop too low. 2. Drain line connected to a floor drain not vented. 	<ol style="list-style-type: none"> 1. Repair to proper 32-inch minimum height. 2. Connect to a vented drain.
Detergent left in dispenser.	<ol style="list-style-type: none"> 1. Detergent allowed to stand too long in dispenser. 2. Dispenser wet when detergent was added. 3. Detergent cover held closed or blocked by large dishes. 4. Improper incoming water temperature to properly dissolve detergent. 5. See "Detergent cover will not open". 	<ol style="list-style-type: none"> 1. Instruct customer/user 2. Instruct customer/user 3. Instruct customer/user on proper loading of dishes. 4. Incoming water temperature of 120°F is required to properly dissolve dishwashing detergents.