

## Overview

The Venice 8 FS2028 module provides a colour touch radio solution for Internet radio, home network streaming, premium streaming content services, DAB/DAB+/DMB-Radio and FM-RDS products. It provides the simplest route to market for premium high-quality audio streaming from live Internet radio stations or network-based music collections.

Several hardware and software configurations are available, with different combinations of integrated RF receivers for Wi-Fi networks, DAB Band III, FM reception and Ethernet.

Based around Frontier Silicon's Chorus 3 processor, Venice 8 streams radio stations and music files in a variety of formats and protocols including AAC+, MP3, Real and WMA, enabling a new generation of stand-alone networked touchscreen-based audio products.

Frontier Silicon also provides a complete reference platform, Jupiter 8, for rapid evaluation of Venice 8 and development of Venice 8-based systems.

Applications include a wide range of audio products, from kitchen and alarm clock radios to CD micro systems, boomboxes and HiFi tuners.

## Modes

- Live Internet radio broadcasts from over 12,000 radio stations
- Internet radio "listen again" on-demand content
- Music streaming from UPnP devices with playlist capability
- Music streaming from USB stick
- Microsoft DRM 10 Streaming (on request)
- DAB Digital Audio Broadcast radio
- DAB+ with additional AAC+ codec
- DMB-Radio (on request)
- FM radio reception with RDS

## Connectivity

- Wi-Fi 802.11b/g with WPS, WEP, WPA and WPA2 security

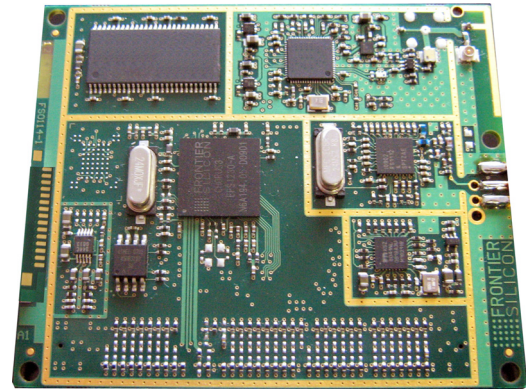

- Full colour graphical UI with touch driven interface
- 10/100 Mb/s Ethernet
- USB 2.0 device or host
- On-board audio DAC with stereo analogue line output
- Digital audio output -S/PDIF or I<sup>2</sup>S
- Infrared remote control
- Rotary encoder

## Features

- Microsoft DRM 10 (digital rights management) playback (on request)
- Codecs: MP3, WMA, AAC+, RealAudio, FLAC, PCM and WAV
- Simple registration and configuration
- Remote control
- Internet portal
- Clock/alarms
- Automatically software upgradable in the field through the Internet or via USB
- UPnP support

## Ordering information

Product code	Description
FS2028-WEB	Wi-Fi, DAB, DAB+, DMB-Radio, FM, Ethernet, USB 2.0, MP3, WMA, AAC+

Further variants are described in [Hardware build options on page 27](#).

## Legal and precautionary notices

Copyright © 2010 Frontier Silicon Ltd. and its licensors. All Rights Reserved.

This document is confidential and proprietary to Frontier Silicon. It may not be copied nor its contents disclosed without written permission from Frontier Silicon. All external recipient organisations must sign a non-disclosure agreement.

This document supersedes all previous versions. In line with its policy of continuous improvement, Frontier Silicon reserves the right to make changes to products and documentation without notice.

Frontier Silicon accepts no liability for any losses alleged to have arisen from use of this document or associated products.

The Frontier Silicon logo is a trademark of Frontier Silicon.

MPEG-4 HE-AAC audio coding technology licensed by Fraunhofer IIS, [www.iis.fraunhofer.de](http://www.iis.fraunhofer.de).

DAB and MP3 technologies are subject to end-user patent licences: please contact Frontier Silicon for more details.



Frontier Silicon Limited  
137, Euston Road  
London  
NW1 2AA  
United Kingdom  
Tel: +44 207 391 0620  
Fax: +44 207 388 6420  
E-mail: [info@frontier-silicon.com](mailto:info@frontier-silicon.com)  
Web: [www.frontier-silicon.com](http://www.frontier-silicon.com)

**CAUTION:** The product(s) described in this document contain static-sensitive parts and must be handled in a static-controlled environment.



Please see also the FCC statement in Section 10.4.

# Contents

	List of figures .....	6
	List of tables .....	7
	Revision history .....	8
	Document maturity key .....	8
	Feedback .....	8
<b>1</b>	<b>Applications .....</b>	<b>9</b>
<b>2</b>	<b>Introduction .....</b>	<b>10</b>
	2.1 Features .....	10
<b>3</b>	<b>Power supplies .....</b>	<b>12</b>
	3.1 Power-on timing .....	12
	3.2 Power-off timing .....	12
	3.3 Reset thresholds .....	12
	3.4 Boot up considerations .....	13
<b>4</b>	<b>Software .....</b>	<b>14</b>
<b>5</b>	<b>Hardware interfaces .....</b>	<b>15</b>
	5.1 J6 main connector pin assignments .....	16
	5.2 Interfaces .....	20
	5.2.1 TFT touchscreen .....	20
	5.2.2 Touchscreen interface .....	21
	5.2.3 Backlight control .....	21
	5.2.4 Rotary Encoder .....	21
	5.2.5 Key switches .....	21
	5.3 Analogue audio .....	22
	5.3.1 Analogue audio output .....	22
	5.3.2 Analogue inputs .....	22
	5.4 Digital audio outputs .....	23
	5.4.1 I <sup>2</sup> S .....	23
	5.4.2 S/PDIF out .....	23

- 5.5 Asynchronous serial port (UART for iPod docking) .....24
- 5.6 Serial control port (SCP) .....24
- 5.7 Ethernet interface .....25
- 5.8 SPI interface .....25
- 5.9 Infrared remote .....26
- 5.10 USB 2.0 interface .....26
- 5.11 General purpose I/O .....26
- 6 Hardware build options ..... 27**
  - 6.1 Main variants and functionality .....27
  - 6.2 Broadcast radio .....27
    - Reception ..... 27
    - Connectors ..... 27
  - 6.3 Wi-Fi antenna connector .....27
  - 6.4 Flash memory .....28
- 7 Performance characteristics ..... 29**
  - 7.1 Introduction .....29
  - 7.2 Wi-Fi performance .....29
  - 7.3 RF performance .....30
    - 7.3.1 DAB Band III ..... 30
    - 7.3.2 FM ..... 30
  - 7.4 Audio performance (internal DAC) .....31
- 8 Electrical specifications ..... 32**
  - 8.1 Absolute maximum ratings .....32
  - 8.2 Operating Conditions (operation outside this range is not guaranteed) .....32
  - 8.3 Typical power consumption .....33
  - 8.4 Main signal levels .....33
- 9 Mechanical specification ..... 34**
  - 9.1 Physical specification .....34
  - 9.2 Physical layout .....35
    - 9.2.1 Connectors ..... 36
- 10 Compliance standards ..... 37**

10.1	Electromagnetic compatibility (EMC) .....	37
10.2	Electrostatic discharge (ESD) protection .....	37
10.3	Restriction of hazardous substances (RoHS) .....	37
10.4	FCC statement .....	38
10.4.1	Caution: Exposure to radio frequency radiation .....	38
10.4.2	Federal Communications Commission notice .....	38
10.4.3	Modifications .....	38
10.5	RF exposure .....	39
10.5.1	Occupational exposure levels .....	39
10.5.2	General public exposure levels .....	39
	<b>Glossary</b> .....	<b>40</b>

## List of figures

Figure 1: Example master mode implementation.....9

Figure 2: Module block diagram.....11

Figure 3: Main connector location and pin numbering scheme (rear view) .....15

Figure 4: (front view) .....15

Figure 5: Module top and side dimensions .....35

Figure 6: RF antenna connector area dimensions .....36

Figure 7: Main board connector .....36

## List of tables

Table 1: Revision history	8
Table 2: Reset threshold levels	12
Table 3: Main connector pin assignment	16
Table 4: TFT control signals (outputs)	20
Table 5: Touchscreen interface	21
Table 6: Backlight control	21
Table 7: Rotary encoder	21
Table 8: Key switches	21
Table 9: Analogue audio output	22
Table 10: Analogue inputs	22
Table 11: I2S bus signals	23
Table 12: S/PDIF audio output	23
Table 13: Asynchronous serial port (UART)	24
Table 14: Serial control port (SCP)	24
Table 15: Ethernet interface	25
Table 16: SPI interface	25
Table 17: Infrared remote	26
Table 18: USB 2.0 interface	26
Table 19: Venice 8 main variants and functionality	27
Table 20: Wi-Fi performance	29
Table 21: DAB Band III performance	30
Table 22: FM performance	30
Table 23: Audio analogue output	31
Table 24: Absolute maximum ratings	32
Table 25: Operating conditions	32
Table 26: Typical power consumption	33
Table 27: Main signal levels	33

## Revision history

Revision number	Date	Document maturity	Description
1	December 2009	Initial	First release
2	December 2010	Preliminary	FCC statement added to Compliance Standards; other minor changes made
3	December 2010	Preliminary	Changes made to FCC statement.

Table 1: Revision history

### Document maturity key

- Initial** Initial data, all subject to change.
- Preliminary** Preliminary data; minor details may be missing or subject to change.
- Complete** All sections complete.
- Revised** Additions/corrections incorporated.
- Obsolete** Document refers to a discontinued or soon-to-be-discontinued product. Withdrawn from external distribution.

### Feedback

To contribute feedback on this document, please e-mail [technical-publications@frontier-silicon.com](mailto:technical-publications@frontier-silicon.com).

Include the following information:

- document title, number and date:  
Venice 8 FS2028 Datasheet, FSM 0002 8613 Rev 3, 15 December 2010,
- section number and heading if referring to a specific part of the document.



# 1 Applications

Venice 8 is designed for high-end mains-powered colour GUI connected audio products including:

- Colour touch Internet radio,
- Kitchen radio,
- Clock radio,
- Table top,
- Semi-portable,
- Tuner products,
- Hi-fi or micro system.

Digital radio and premium streaming audio services' availability varies by country, so different markets require different hardware and software builds of the module. The main target markets for Venice 8-based systems currently include the US, UK, Europe and Australia.

*Figure 1* shows a typical implementation, with the module functioning as main system controller.

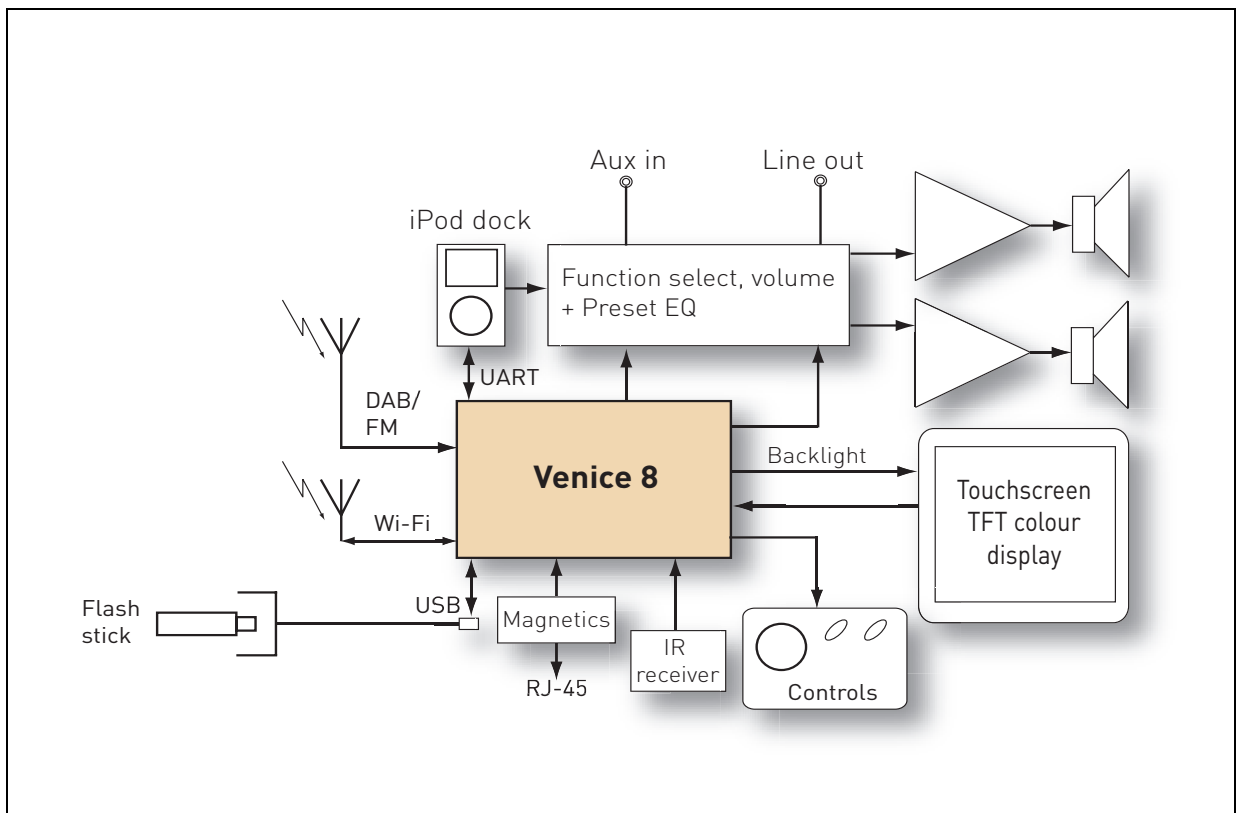

Figure 1: Example master mode implementation

## 2 Introduction

Venice 8 has been designed as the next step in the evolution of connected audio products. Based around the new Frontier Silicon Chorus 3 baseband audio processor, it builds on the functionality of the Venice 6.2 Internet radio module to facilitate a new type of touchscreen connected audio product, with new features, performance and ergonomics ensuring the highest possible performance.

Venice 8 features a new, highly customisable UI, making full use of the latest TFT display technology with resistive touch, to improve ease-of-use.

### 2.1 Features

Figure 2 shows a block diagram of Venice 8. The main components are the RF front end, Chorus 3 FS1230 baseband processor, serial boot Flash, SDRAM and audio DAC.

The Chorus 3 processor is based around a high performance advanced RISC/DSP. In addition to the core DAB demodulation functions, this processor is well suited to running digital radio/connected audio application code.

Venice 8 measures 65 x 80 mm (see [Chapter 9: Mechanical specification](#)). All components are mounted on the top of the module. The underside of the module has a solid copper ground plane. With the exception of the connectors and screw holes, all components are fitted inside the four-chamber screening can. The RF, Wi-Fi, baseband and analogue audio sections are all screened from each other.

Venice 8 has been designed to use a 3.5 inch TFT colour touchscreen module with a resolution of QVGA (320 x 240) and an LED backlight.

Stereo audio outputs are provided in analogue line level and S/PDIF digital formats

Venice 8 has two MAC addresses, one for Wi-Fi and one for Ethernet. It is supplied with 4 MAC address labels for the Wi-Fi (the Ethernet MAC address is the Wi-Fi MAC address plus one).

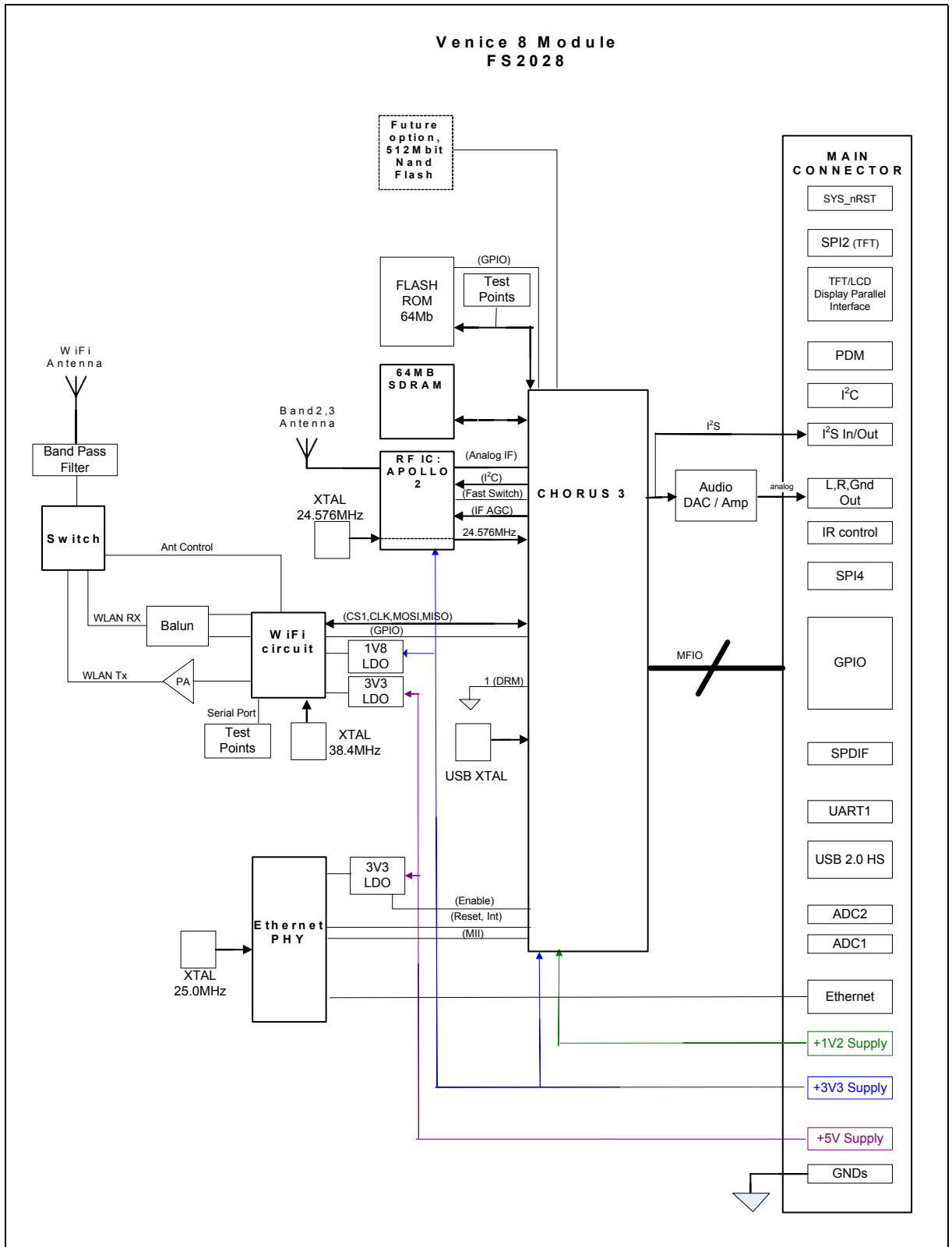

Figure 2: Module block diagram

### 3 Power supplies

Venice 8 requires a  $1.2\text{ V} \pm 5\%$ , supply for the digital baseband and  $3.3\text{ V} \pm 5\%$  for the RF circuits and other baseband devices such as the audio DAC and  $5\text{ V} \pm 5\%$  for Wi-Fi and Ethernet . All supplies should be clean with low ripple. Any noise on these supplies will affect performance.

The module includes some supply filtering on its DC supply lines. This takes the form of a Pi network with a ferrite bead inductor in the supply line and with one or more capacitors to ground on either side.

The voltage rails must be regulated with over-specified regulators and bulk decoupling to cope with the burst requirements of the DAB receiver, Wi-Fi TX and to reduce noise and ripple. The capacitors and regulators should be mounted as close as possible to J1.

For best performance, the system PCB should include a solid ground plane. If this is not possible, the PCB should use large power tracks, with the ground connections from each regulator and smoothing capacitor joining close to the module.

#### 3.1 Power-on timing

The 5.0 V, 3.3 V and 1.2 V supplies may be applied in any order but extended periods of delay should be avoided.

#### 3.2 Power-off timing

Venice 8 is designed so that the power can be removed in any order at any time without affecting the module.

#### 3.3 Reset thresholds

The 1.2 V, 3V3 and 5V supplies to Venice 8 should be kept within the operating limits. The module’s operation may become unstable if the supply deviates from these limits.

Venice 8 incorporates an on-board reset to cope with supply interruptions.

Supply	Symbol	Parameter	Typ	Units
3.3V	$V_{TH+}$	Reset threshold rising level	2.25	V
	$V_{TH-}$	Reset threshold falling level	2.15	
1.2V	$V_{TH+}$	Reset threshold rising level	0.95	
	$V_{TH-}$	Reset threshold falling level	0.90	

Table 2: Reset threshold levels

### 3.4 **Boot up considerations**

1. Care must be taken to ensure that SPDIF\_OUT (pin 19) is driven low during the reset cycle.
2. USB\_VBUS\_FAULT (pin 38) must not have any external pull-ups fitted as there is a 100 k $\Omega$  in the module. Failure to do this will result in boot up problems.

## 4 Software

Frontier Silicon normally provides Venice 8 pre-installed with software. This can be configured to customer requirements.

The module is intended to be used as the basis for a standalone connected audio system (see [Figure 1 on page 9](#)). The only external parts needed are a power source, antenna(s), TFT touchpad display, infrared receiver, backlight, iPod authentication, keypad (two switches), rotary encoder (optional), amplifier and speaker(s).

Soft FM (RDS) software allows the module to function as an FM radio receiver without the need for a separate FM tuner chip. An FM user interface provides access to all RDS features.

Please contact Frontier Silicon for further information.

# 5 Hardware interfaces

Venice 8 supports numerous hardware interfaces (physical layout shown in [Section 9.2.1](#)). The characteristics of these interfaces are detailed below.

*Note: Some of these interfaces may be mutually exclusive.*

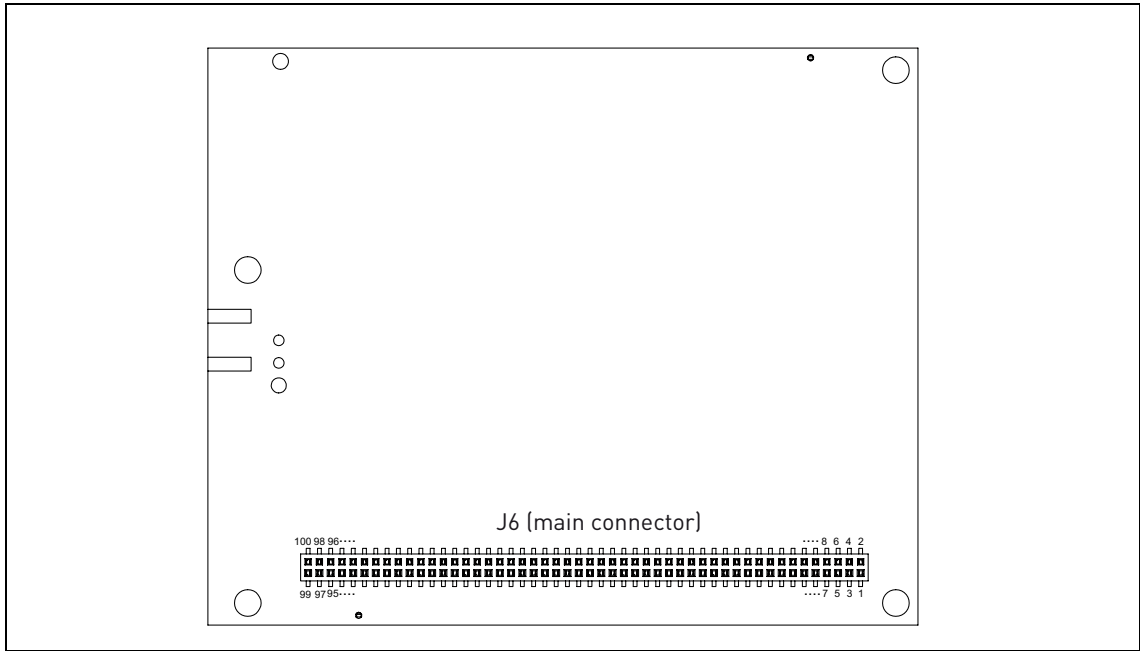

Figure 3: Main connector location and pin numbering scheme (rear view)

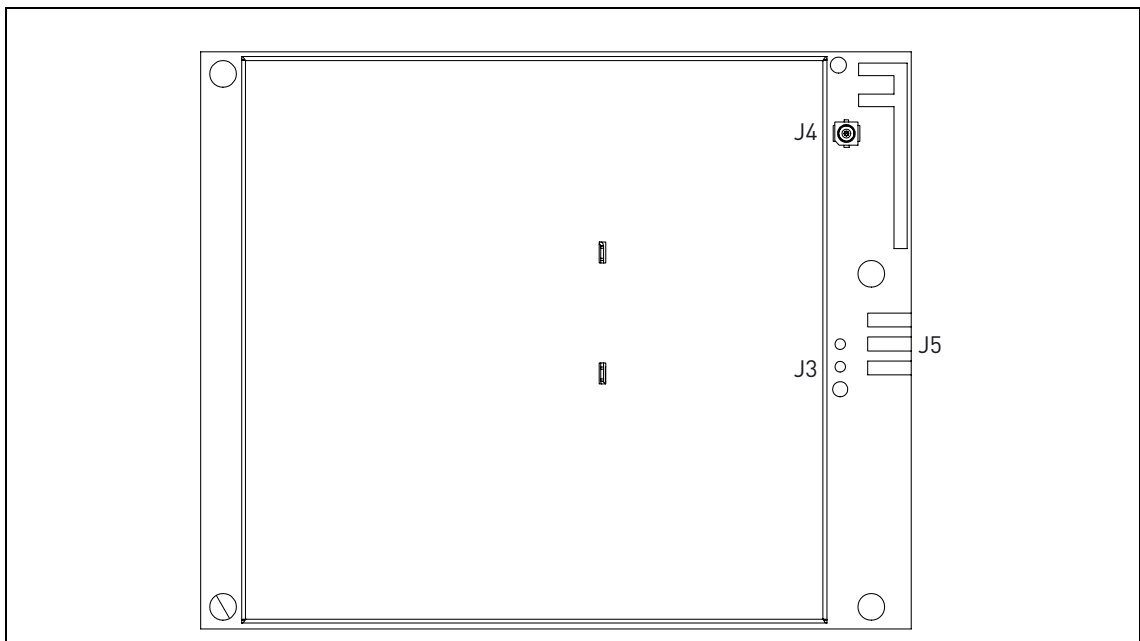

Figure 4: (front view)

## 5.1 J6 main connector pin assignments

Pin no	Pin name	Usage	Alternative Usage	Drive (mA)
1	5V_Input	5V supply	-	-
2	1V2_Input	1.2 supply	-	-
3	GND	Ground	-	-
4	3V3_Input	3.3V supply	-	-
5	AUD_L	Analogue output left	-	DAC
6	AUD_R	Analogue output right	-	DAC
7	GND	Ground	-	-
8	AUD_GND	Audio ground	-	-
9	I2S_MCLK_FILT	I2S	GPIO	4
10	GND	Ground	-	-
11	I2S_SCLK_FILT	I2S	GPIO	4
12	I2S_SFR_FILT	I2S	GPIO	4
13	I2S_SDIN	I2S	GPIO	4
14	I2S_SDOUT0_FILT	I2S	GPIO	4
15	AUDIO_MUTE	Audio control	GPIO	4
16	AUDIO_AMP_ON	Audio control	GPIO	4
17	HEADPHONE_DET	Audio control	GPIO	8
18	SPDIF_PWR_SW	SPDIF	GPIO	4
19	SPDIF_OUT	SPDIF	GPIO	4
20	IPOD_ACC_POWER	iPod	GPIO	4
21	IPOD_DET	iPod	GPIO	4
22	S1_DIN	iPod	GPIO	4
23	S1_DOUT	iPod	GPIO	8
24	SPI1_SCK_F	SPI	-	4
25	SPI1_MISO2	SPI	GPIO	8
26	SPI1_MOSI_F	SPI	-	4
27	SPI_CS <sub>n</sub> 4	SPI	GPIO	8
28	SPI_CS <sub>n</sub> 2	SPI	GPIO	4
29	SPI1_MISO4/ IPOD_ACC_DET	iPod	GPIO	8
30	SCP1_CLK	I2C	GPIO	8
31	SCP1_DATA	I2C	GPIO	8
32	GND	Ground	-	-

Table 3: Main connector pin assignment



Pin no	Pin name	Usage	Alternative Usage	Drive (mA)
33	USB_DP	USB D+	-	A
34	USB_DN	USB D-	-	A
35	USB_VBUS	USB	-	A
36	USB_COM	Ground	-	-
37	USB_VBUS_DRIVE	USB	GPIO	4
38	USB_VBUS_FAULT	USB	GPIO	4
39	GND	Ground	Ground	-
40	GP_ADC1	Analogue input	-	A
41	GP_ADC0	Analogue input	-	A
42	SYS_nRST	Module reset	-	8
43	IR_REMOTE	IR	GPIO	8
44	KYBRD_COL_2	GPIO	GPIO	8
45	KYBRD_COL_1	GPIO	GPIO	8
46	KYBRD_COL_4	GPIO	GPIO	8
47	KYBRD_COL_3	GPIO	GPIO	8
48	KYBRD_ROW_2	GPIO	GPIO	8
49	KYBRD_ROW_1	GPIO	GPIO	8
50	MFIO_87	GPIO	-	4
51	MFIO_85	GPIO	-	8
52	MFIO_86	GPIO	-	8
53	MFIO_82	GPIO	-	8
54	MFIO_81	GPIO	-	8
55	MFIO_83	GPIO	-	8
56	MFIO_84	GPIO	-	8
57	MFIO_88	GPIO	-	4
58	MFIO_73	GPIO	-	8
59	GND	Ground	-	-
60	MFIO_89	GPIO	-	4
61	TFT_VDDEN_GD	TFT Display	GPIO	4
62	GND	Ground	-	-
63	TFT_BLUE_4	TFT Display	GPIO	4
64	TFT_BLUE_5	TFT Display	GPIO	4

Table 3: Main connector pin assignment

Pin no	Pin name	Usage	Alternative Usage	Drive (mA)
65	TFT_BLUE_2	TFT Display	GPIO	4
66	TFT_BLUE_3	TFT Display	GPIO	4
67	TFT_BLUE_0/ MFIO_117	TFT Display	GPIO	4
68	TFT_BLUE_1	TFT Display	GPIO	4
69	TFT_GREEN_4	TFT Display	GPIO	4
70	TFT_GREEN_5	TFT Display	GPIO	4
71	TFT_GREEN_2	TFT Display	GPIO	4
72	TFT_GREEN_3	TFT Display	GPIO	4
73	TFT_GREEN_0	TFT Display	GPIO	4
74	TFT_GREEN_1	TFT Display	GPIO	4
75	GND	Ground	-	-
76	GND	Ground	-	-
77	TFT_RED_4	TFT Display	GPIO	4
78	TFT_RED_5	TFT Display	GPIO	4
79	TFT_RED_2	TFT Display	GPIO	4
80	TFT_RED_3	TFT Display	GPIO	4
81	TFT_RED_0/MFIO_105	TFT Display	GPIO	4
82	TFT_RED_1	TFT Display	GPIO	4
83	TFT_HSYNC_NR	TFT Display	GPIO	4
84	TFT_PANELCLK	TFT Display	GPIO	4
85	TFT_BLANK_LS	TFT Display	GPIO	4
86	TFT_VSYNC_NS	TFT Display	GPIO	4
87	TFT_PWRSAVE	TFT Display	GPIO	4
88	TFT_VD12ACB	TFT Display	GPIO	4
89	DIM_F	PDM	GPIO	4
90	TOUCH_SCR_INTn_F	GPIO	GPIO	4
91	GND	Ground	-	-
92	GND	Ground	-	-
93	ETH_TX+	Ethernet	-	PHY
94	ETH_SPEED	Ethernet LED	-	PHY
95	ETH_GND	Ground	-	PHY
96	ETH_TX-	Ethernet	-	PHY
97	ETH_RX+	Ethernet	-	PHY
98	ETH_CT	Ethernet	-	PHY

**Table 3: Main connector pin assignment**

<b>Pin no</b>	<b>Pin name</b>	<b>Usage</b>	<b>Alternative Usage</b>	<b>Drive (mA)</b>
99	ETH_NWAYEN	Ethernet LED	-	PHY
100	ETH_RX-	Ethernet	-	PHY

**Table 3: Main connector pin assignment**

## 5.2 Interfaces

### 5.2.1 TFT touchscreen

Venice 8 supports 18 bit TFT displays. The Venice 8 module supports a 240 x 320 pixel transmissive display with LED backlight.

Pin no	Pin name	Pin description
<b>Outputs</b>		
88	TFT_VD12ACB	12V digital supply enable or AC bias output
87	TFT_PWRSAVE	Power save (Shut down display)
84	TFT_PANELCLK	Pixel clock
83	TFT_HSYNC_NR	Horizontal synchronisation pulse
85	TFT_BLANK_LS	Data output enable
86	TFT_VSYNC_NS	Vertical synchronisation pulse
61	TFT_VDDEN_GD	TFT panel VDD enable
81	TFT_RED_0/MFIO_105	Red data bit 0
82	TFT_RED_1	Red data bit 1
79	TFT_RED_2	Red data bit 2
80	TFT_RED_3	Red data bit 3
77	TFT_RED_4	Red data bit 4
78	TFT_RED_5	Red data bit 5
67	TFT_BLUE_0/MFIO_117	Blue data bit 0
68	TFT_BLUE_1	Blue data bit 1
65	TFT_BLUE_2	Blue data bit 2
66	TFT_BLUE_3	Blue data bit 3
63	TFT_BLUE_4	Blue data bit 4
64	TFT_BLUE_5	Blue data bit 5
73	TFT_GREEN_0	Green data bit 0
74	TFT_GREEN_1	Green data bit 1
71	TFT_GREEN_2	Green data bit 2
72	TFT_GREEN_3	Green data bit 3
69	TFT_GREEN_4	Green data bit 4
70	TFT_GREEN_5	Green data bit 5

**Table 4: TFT control signals (outputs)**

### 5.2.2 Touchscreen interface

Pin no	Pin name	Pin description
90	TOUCH_SCR_INTn_F	Touchscreen pen down interrupt
30	SCP_CLK	I2C bus clock (shared with other peripherals)
31	SCP1_DAT	I2C bus clock (shared with other peripherals)

Table 5: Touchscreen interface

### 5.2.3 Backlight control

Backlight control of the LCD can be achieved using a Linear Tech LT3465 which varies the current provided to the backlight with an analogue voltage. On Venice 8 a PDM output is converted to an analogue voltage using an onboard RC filter.

Pin no	Pin name	Pin description
89	DIM_F	Backlight control. Pulse density modulated output1 filtered to an analogue voltage

Table 6: Backlight control

### 5.2.4 Rotary Encoder

Two GPIO are dedicated to implement a rotary encoder for volume control. The push to mute or select function is implemented as on of the dedicated Key Switches.

Pin no	Pin name	Pin description
48	KYBRD_ROW_2	Rotary encoder I/P
49	KYBRD_ROW_1	Rotary encoder I/P

Table 7: Rotary encoder

### 5.2.5 Key switches

Four GPIO are dedicated for key switches to interact with the UI.

Pin no	Pin name	Pin description
45	KYBRD_COL_1	Snooze
44	KYBRD_COL_2	Standby
47	KYBRD_COL_3	Spare
46	KYBRD_COL_4	Rotary push

Table 8: Key switches

### 5.3 Analogue audio

#### 5.3.1 Analogue audio output

The onboard audio DAC provides an analogue stereo line-level output.

Pin number	Pin name	Pin description
5	AUD_L	Analogue audio output left
6	AUD_R	Analogue audio output right
7	AUD_GND	Audio ground
15	AUDIO_MUTE	Audio mute
16	AUDIO_AMP_ON	Amp on
17	HEADPHONE_DET	Headphones detect

Table 9: Analogue audio output

#### 5.3.2 Analogue inputs

Venice 8 has two analogue inputs for functions such as measuring battery voltage, ambient lights etc.

Pin number	Pin name	Pin description
41	GP_ADC0	Analogue input 0
40	GP_ADC1	Analogue input 1

Table 10: Analogue inputs

## 5.4 Digital audio outputs

### 5.4.1 I<sup>2</sup>S

An I<sup>2</sup>S bus is provided, comprising of a master clock, bit clock, sample frame, and stereo out for basic stereo operation with an external DAC or CODEC. A bank of four 0R resistors can be fitted on the I<sup>2</sup>S bus. These have been removed by default to enhance EMC performance. If required a variant can be provided that supports I<sup>2</sup>S out.

Sample Rate: 48 kHz

Master Clock Rate: 256/384 x sample rate (24.576 MHz)

Sample Resolution: 16, 18, 20 or 24 bits (controlled by software)

Pin number	Pin name	Pin description
9	I2S_MCLK_FILT	I <sup>2</sup> S audio master clock
12	I2S_SFR_FILT	I <sup>2</sup> S serial audio frame
11	I2S_SCLK_FILT	I <sup>2</sup> S serial audio data clock
14	I2S_SDOUT0_FILT	I <sup>2</sup> S serial audio data out channel 0
13	I2S_SDIN	I <sup>2</sup> S serial audio data in

Table 11: I2S bus signals

### 5.4.2 S/PDIF out

The S/PDIF out signal is provided on the main connector. The S/PDIF audio output carries a stereo digital audio output on a single wire using the signal format defined in IEC60958.

Sample Rate: 48 kHz

Sample Resolution: 24 bits

Pin number	Pin name	Pin description
18	SPDIF_PWR_SW	GPIO to control power to SPDIF device (shared with other peripherals)
19	SPDIF_OUT	S/PDIF out

Table 12: S/PDIF audio output

Note: SPDIF\_OUT must be low during reset for reliable booting.

### 5.5 Asynchronous serial port (UART for iPod docking)

The UART provides a standard asynchronous serial port with a maximum speed of 115200 baud.

Pin number	Pin name	Pin description
23	S1_DOUT	Serial port data out
22	S1_DIN	Serial port data in
21	IPOD_DET	iPod detect
20	IPOD_ACC_POWER	Accessory power
29	IPOD_ACC_DET	Accessory detect

Table 13: Asynchronous serial port (UART)

### 5.6 Serial control port (SCP)

The serial control port (I<sup>2</sup>C-compatible) is a bidirectional, 2-wire, open-collector style bus and other external peripherals..

The functionality of the SCP is master/slave transmitter/receiver in standard or fast mode (100/400 kHz). Multi-master operation is not supported. The SCP pins are NOT 5 V-tolerant.

Pin number	Pin names	Pin description
31	SCP1_DATA	I2C bus data (shared with other peripherals)
30	SCP1_CLK	I2C bus clock (shared with other peripherals)

Table 14: Serial control port (SCP)

Note: These pins require external pull-ups to 3.3V (4.7 kΩ).



## 5.7 Ethernet interface

Venice 8 supports 10/100BaseT Ethernet. An RJ-45 Mag Jack (Magnetic Jack) is required on the application to provide the necessary isolation and connection to a wired network.

Routing from the module to the RJ-45 must be 100  $\Omega$  differential impedance controlled transmission lines.

Pin number	Pin name	Pin description
93	ETH_TX+	Physical transmit or receive signal (+ differential)
94	ETH_SPEED	Ethernet Speed LED
96	ETH_TX-	Physical transmit or receive signal (- differential)
97	ETH_RX+	Physical receive or transmit signal (+ differential)
98	ETH_CT	Supply for Magnetics centre tap
99	ETH_NWAYEN	Ethernet Link LED control
100	ETH_RX-	Physical receive or transmit signal (- differential)

Table 15: Ethernet interface

## 5.8 SPI interface

The serial peripheral interface (SPI) pins can be used to interface the Venice 8 module to an SPI display.

Pin number	Pin name	Pin description
24	SPI1_SCK_F	SPI serial clock
25	SPI1_MISO2	SPI master input
26	SPI_MOSI_F	SPI master output
27	SPI_CS <sub>n</sub> 4	SPI chip select 4
28	SPI_CS <sub>n</sub> 2	SPI chip select 2
29	SPI1_MISO4	SPI master Input

Table 16: SPI interface

Venice 8 has multiple MISO lines. Should an SPI device not tri-state its data output line. If you have two SPI devices and they both tri-state their serial data outputs then you can save one of the MISO pins.

## 5.9 Infrared remote

An infrared remote (IR) interface is present on the main connector. The Philips RC5 IR protocol is supported.

Pin number	Pin name	Pin description
43	IR_REMOTE	IR remote

Table 17: Infrared remote

## 5.10 USB 2.0 interface

The USB 2.0 interface supports device and host operation in USB hi-speed and full speed modes.

Pin number	Pin name	Pin description
34	USB_DN	USB differential data (negative)
33	USB_DP	USB differential data (positive)
36	USB_COM	Ground
35	USB_VBUS	USB supply present
38	USB_VBUS_FAULT	USB power supply fault
37	USB_VBUS_DRIVE	USB Power supply enable

Table 18: USB 2.0 interface

*Note: USB\_DN and USB\_DP should be routed as 90 Ω balanced differential pair.*

## 5.11 General purpose I/O

There are several dedicated GPIO lines, but as described above, many of the other digital interfaces have alternative usage as additional GPIO.

Each GPIO line may be configured by software as an input or output. The state of each GPIO input can be read by software. The logic level and tri-state drive of each GPIO output can be controlled by software.

## 6 Hardware build options

Venice 8 has been designed for flexibility in application and use. The following hardware build options can be provided.

### 6.1 Main variants and functionality

Product code		Wi-Fi	DAB	FM	Ethernet
FS2028-	W	•			
	WB	•	•	•	
	WF	•		•	
	WE	•			•
	WEB	•	•	•	•
	WEF	•		•	•

Table 19: Venice 8 main variants and functionality

### 6.2 Broadcast radio

#### Reception

Venice 8 can be supplied with or without broadcast radio reception components for DAB/DAB+/DMB-Radio/FM.

#### Connectors

the DAB/DMB-Radio/FM RF inputs, can be fitted with any one of the following RF connectors:

- UMP,
- SMA,
- SMB,
- KRD (0.2" 2 pin header),
- none.

If no connector is fitted, connection can be made to J3 with a coaxial flying lead (pig-tail, 75 Ω).

### 6.3 Wi-Fi antenna connector

J4, the Wi-Fi antenna connector, can be fitted with either of the following RF connectors:

- On board PIFA,
- IPEX
- Direct solder connector

If no connector is fitted, the onboard Wi-Fi PCB antenna is used.

## 6.4 Flash memory

Venice 8 will support 64Mbit Flash memory and also has potential for future support of 512Mbits (64Mbytes (x8) of NAND Flash.

## 7 Performance characteristics

### 7.1 Introduction

Venice 8 is a Eureka 147 DAB receiver conforming to EN61000-4-2 supporting Band 3 and Korean Band 3 with typical performance equal to or better than EN50248:2001 [\[reference 9\]](#).

Venice 8 supports Band 2 Soft FM (87.5 MHz to 108 MHz) and meets parts of the BS 5942-2:1987 Hi-Fidelity minimum performance when tested to BS 60315-4 [\[reference 10\]](#).

For the following specifications, operating conditions are  $T_a = 25^\circ\text{C}$ ,  $V_{CC} = 3.3\text{ V}$ .

### 7.2 Wi-Fi performance

Venice 8 supports the mandatory modes required by 802.11b and 802.11g plus some optional modes, as listed in [Table 20](#). The maximum transmit power of the Wi-Fi module is limited to 20 dBm Effective Isotropic Radiated Power (EIRP). The Wi-Fi module's transmit power and the antenna gain added together must not exceed 20 dBm EIRP.

Standard	Mode	Bit rate, Mbit/s	Receiver sensitivity		
			Min	Typ	Units
802.11b	DSSS	1	-79	-92	dBm @ 8%PER
	DSSS	2	-79	-92	
	HR/DSSS	5.5	-79	-91	
	HR/DSSS	11	-79	-87	
802.11g	ERP-OFDM	6	-82	-86	dBm @10% PER
		9	-81	-85	
		12	-79	-85	
		18	-77	-84	
		24	-74	-80	
		36	-70	-79	
		48	-66	-73	
		54	-65	-72	

Table 20: Wi-Fi performance

For a nominal transmit power of 15 dBm, the minimum power is 12.5 dBm, and the maximum is 17 dBm.

### 7.3 RF performance

The terrestrial radio RF input for DAB band III and FM band II is AC coupled to cater for DC powered distribution systems.

#### 7.3.1 DAB Band III

Operating mode = decoding one DAB stereo audio channel at 192 kbit/s.

Parameters		Min	Typ	Max	Units
Tuning range	Band III	174.928	-	214.736	MHz
	Korean Band III	174.928	-	239.200	
Large signal		-5	0		dBm
Sensitivity		-97	-99		
Far off selectivity		40	65		dB
Adjacent channel rejection		35	38		

Table 21: DAB Band III performance

#### 7.3.2 FM

Operating mode = decoding one FM stereo audio channel at +/- 67.5 kHz with 1 kHz tone.

Parameters	Min	Typ	Max	Units
Band 2 tuning range	87.5	-	108	MHz
Sensitivity (S+N)/N=26 dB	-106	-108	-	dBm
Large signal handling capacity	-	0	-	
(S+N)/N ultimate signal-to-noise ratio (mono)	-	50	-	dB
THD (1 kHz, mono, A-weighted)	-	0.3	-	%
Tuning step size	-	50	-	KHz
FM selectivity (mono) ± 200 kHz	-	TBD	-	dB
Stereo separation	25	40	-	

Table 22: FM performance

## 7.4 Audio performance (internal DAC)

Operating conditions: internal DAC, 40 Hz - 12.5 kHz

Parameter	Min	Typ	Max	Units	Comments
Load resistance	3.0		-	k $\Omega$	To mid-rail or AC coupled
Signal level	-	0.6	-	V <sub>RMS</sub>	into 10 k $\Omega$
THD (full scale)	-	0.01	0.02	%	THD full scale
SNR	95	97	-	dB	In DAB mode
3 dB audio bandwidth (referenced to 1 kHz level)	<20	-	20000	Hz	
	<40	-	12500	Hz	In FM mode

Table 23: Audio analogue output

## 8 Electrical specifications

### 8.1 Absolute maximum ratings

**CAUTION:** Exceeding these values may damage the module.

Parameter	Min	Typ	Max	Comments	Units
Total standby power	-	-	1	Complies with Eco certification	W
5 V power terminal	0	5	5.5		V
3.3 V power terminal	0	3.3	3.63		
1.2 V power terminal	0	1.2	1.32		
V <sub>IN</sub>	1.17	-	3.3V	Other than supply pins	
Storage temperature	-40	-	+85		°C
Operating temperature	0	-	+60		
Humidity	0	-	90	Non-condensing	%
RF input		-	+10		dBm
Other inputs	-0.3	-	3.6		V
Outputs	-20	-	+20		mA

Table 24: Absolute maximum ratings

### 8.2 Operating Conditions (operation outside this range is not guaranteed)

Parameter	Min	Typ	Max	Units
5V power terminal	4.75	5	5.25	V
3.3V power terminal	3.135	3.3	3.316	
1.2V power terminal	1.14	1.2	1.26	

Table 25: Operating conditions



### 8.3 Typical power consumption

Table 26 shows typical power consumption at a temperature of 25 °C. This includes GPIO driving current to the display, but not the display backlight, the current for which is supplied externally to the module.

Operating Mode	Supply Voltage	Supply Current (mA)	
		Typical	Maximum
DAB only	5.0V	0	5
	3.3V	197	230
	1.2V	97	130
Soft FM only	5.0V	0	5
	3.3V	203	230
	1.2V	95	130
Wi-Fi Internet radio	5.0V	1	5
	3.3V	390	450
	1.2V	105	140
Ethernet Internet radio	5.0V	112	130
	3.3V	194	230
	1.2V	106	130
iPod play back	5.0V	0	5
	3.3V	146	180
	1.2V	89	120

Table 26: Typical power consumption

### 8.4 Main signal levels

Parameter	Min	Typ	Max	Units
LOW level input voltage	-	-	0.8	V
HIGH level input voltage	2	-	-	
Schmitt trigger low-to-high threshold	1.67	1.73	1.79	
Schmitt trigger high-to-low threshold	1.01	1.07	1.15	

Table 27: Main signal levels

## 9 Mechanical specification

Reflecting the fact that Venice 8 is designed for a completely new kind of connected audio device, the module has a new form factor 65 x 80 mm, and is not backwards-compatible with previous Frontier Silicon radio modules.

### 9.1 Physical specification

Venice 8 is a single-sided assembly built with a 8-layer printed circuit board. The RF and baseband circuitry are shielded to meet EMC and RF performance specifications. The shielding separates the RF and baseband sections.

The mating connector for Venice 8 is:

Manufacturer: Samtec

Description: Con PLG 100 way (50 x 2) pin header vertical 1.27 SMT

Part number: REF-146673-01



9.2.1 Connectors

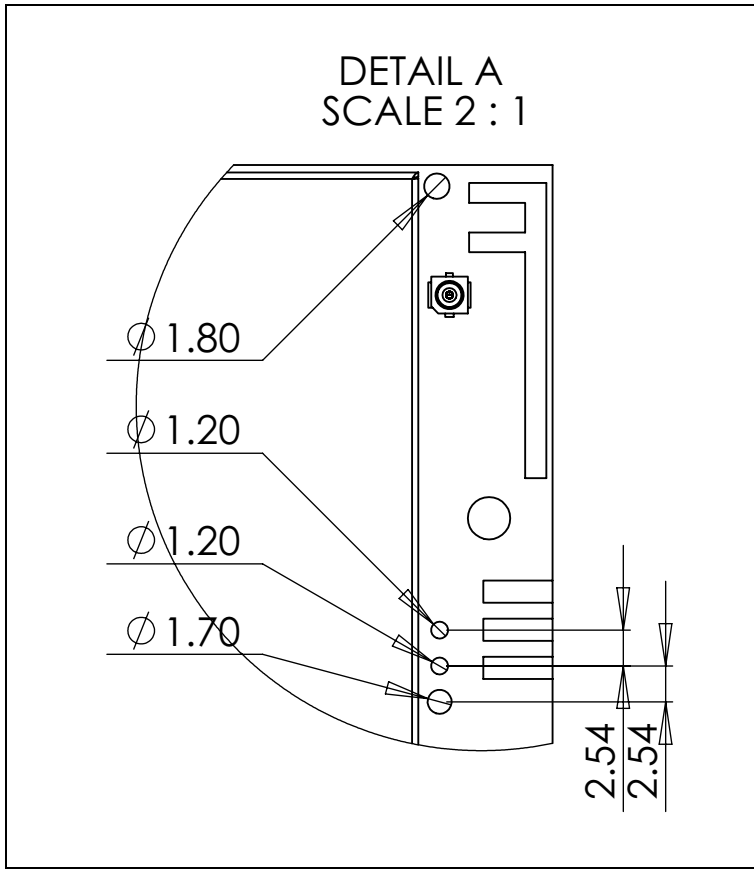

Figure 6: RF antenna connector area dimensions

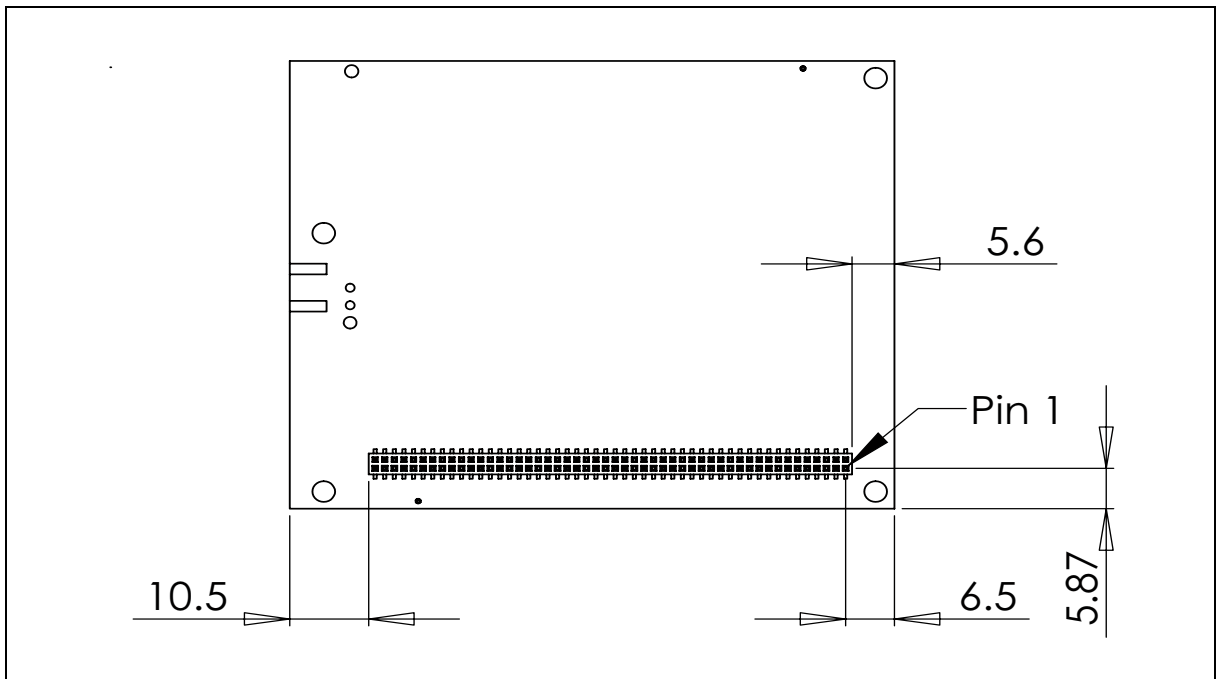

Figure 7: Main board connector

## 10 Compliance standards

Venice 8 is designed to allow customers' finished products to gain compliance with the following certifications:

- CE,
- Wi-Fi Alliance,
- DLNA 1.5,
- WWi,
- MFi,
- FCC.

### 10.1 Electromagnetic compatibility (EMC)

Venice 8 is tested in configurations representative of typical DAB consumer products to the following standards:

- BS EN 55013: 2001 for emissions,
- BS EN 55020: 2002 for immunity.

The electromagnetic compatibility of a particular product is dependent upon the use and installation of the module within the product. Care should be taken to integrate the module with due regard to the effects of conducted and radiated signals.

### 10.2 Electrostatic discharge (ESD) protection

Venice 8 is an ESD-sensitive device. It is tested to the standard EN61000 (4 kV on RF inputs). Special handling precautions should be used during manufacturing and testing.

### 10.3 Restriction of hazardous substances (RoHS)

All Frontier Silicon products meet the requirements of the EU RoHS directive 2002/95/EC RoHS, use RoHS-certified components and are assembled using lead-free processes. See the *Frontier Silicon Declaration of Materials Compliance* [\[reference 2\]](#).

Additionally, Frontier Silicon adheres to best industry practice regarding the avoidance of environmentally harmful substances in products, above and beyond legal requirements such as RoHS.

## 10.4 FCC statement

The Venice 8 module is conformant with FCC standards under the "modular approval" only. The FCC ID for the Venice 8 module is YYX-HA-FS2028-F.

### DECLARATION OF CONFORMITY WITH FCC RULES FOR ELECTROMAGNETIC COMPATIBILITY

Frontier Silicon Limited declares under its sole responsibility that the product FCC-ID: YYX-HA-FS2028-F, to which this declaration relates, complies with Part 15 of the FCC Rules in WiFi operating mode only.

It is the responsibility of the final product manufacturer to achieve conformance with Part 15 of the FCC rules for all other operating modes, in the final application. The Venice 8 module is compliant with Part 15 of the FCC Rules in WiFi, DAB, FM and Ethernet modes in Frontier Silicon's reference platform Jupiter 8.

Operation is subject to the following two conditions:

- (1) This device may not cause harmful interference, and
- (2) this device must accept any interference received, including interference that may cause undesired operation.

The manufacturer of the final product containing the Venice 8 module must ensure that the product includes an exterior label with the following wording: "Contains FCC ID: YYX-HA-FS2028-F".

### 10.4.1 Caution: Exposure to radio frequency radiation

The device is compliant to FCC standards in terms of radiated signal levels. Nevertheless, the device shall be used in such manner that proximity and the potential for human contact with the radiating antenna, during normal operation, is minimised.

In order to avoid the possibility of exceeding the FCC radio frequency exposure limits, human proximity to the antenna shall not be less than 20cm (8 inches) during normal operation.

See the Venice 8 Application Note for further information.

### 10.4.2 Federal Communications Commission notice

This equipment has been tested and found to comply with the limits for a Class B digital device, pursuant to Part 15 of the FCC Rules. These limits are designed to provide reasonable protection against harmful interference in a residential installation.

This equipment generates, uses, and can radiate radio frequency energy. If not installed and used in accordance with the instructions, it may cause harmful interference to radio or television reception, which can be determined by turning the equipment off and on, in which case the user is encouraged to try and correct the interference by increasing the distance between the equipment and the receiver.

### 10.4.3 Modifications

The FCC requires the user to be notified that any changes or modifications to this device that are not expressly approved by Frontier Silicon Limited may void the user's authority to operate the equipment. Such modifications also invalidate FCC approval of the device.

## **10.5 RF exposure**

### **10.5.1 Occupational exposure levels**

The Venice 8 module meets the Occupational Exposure Levels described in the ICNIRP Guidelines, FCC 47 CFR § 1.1310 Guidelines, Health Canada's RF exposure guideline Safety Code 6 and the Australian ARPANSA limits at 20.0cm, the point of investigation.

### **10.5.2 General public exposure levels**

The Venice 8 module meets the General Public Exposure Levels described in the ICNIRP Guidelines, FCC 47 CFR § 1.1310 Guidelines, Health Canada's RF exposure guideline Safety Code 6 and the Australian ARPANSA limits at 20.0cm, the point of investigation.

## Glossary

<b>DAB</b>	Digital Audio Broadcasting
<b>FM</b>	Frequency Modulation
<b>GPIO</b>	General Purpose Input/Output
<b>IC</b>	Integrated Circuit
<b>RDS</b>	(FM) Radio Data System
<b>SCP</b>	Serial Control Protocol
<b>SPI</b>	Serial Peripheral Interface
<b>SPI master</b>	Provides SPI clock and initiates data transactions and requests
<b>SPI slave</b>	Receives SPI clock and responds to data transactions and requests
<b>S/PDIF</b>	Sony/Philips Digital Interface
<b>SRAM</b>	Static Random Access Memory
<b>TFT</b>	Thin Film Transistor [display]
<b>UART</b>	Universal Asynchronous Receiver Transmitter
<b>USB</b>	Universal Serial Bus
<b>WWi</b>	Works With iPhone



