



# H50 Series Gas Fryers

Service and Parts Manual



Frymaster, a member of the Commercial Food Equipment Service Association, recommends using CFESA Certified Technicians.

24-Hour Service Hotline 1-800-551-8633

JUNE 2005

\* 8190001 \*

**NOTICE**

IF, DURING THE WARRANTY PERIOD, THE CUSTOMER USES A PART FOR THIS ENODIS EQUIPMENT OTHER THAN AN UNMODIFIED NEW OR RECYCLED PART PURCHASED DIRECTLY FROM FRYMASTER/DEAN, OR ANY OF ITS AUTHORIZED SERVICE CENTERS, AND/OR THE PART BEING USED IS MODIFIED FROM ITS ORIGINAL CONFIGURATION, THIS WARRANTY WILL BE VOID. FURTHER, FRYMASTER/DEAN AND ITS AFFILIATES WILL NOT BE LIABLE FOR ANY CLAIMS, DAMAGES OR EXPENSES INCURRED BY THE CUSTOMER WHICH ARISE DIRECTLY OR INDIRECTLY, IN WHOLE OR IN PART, DUE TO THE INSTALLATION OF ANY MODIFIED PART AND/OR PART RECEIVED FROM AN UNAUTHORIZED SERVICE CENTER.

**NOTICE**

This appliance is intended for professional use only and is to be operated by qualified personnel only. A Frymaster/DEAN Factory Authorized Service Center (FASC) or other qualified professional should perform installation, maintenance, and repairs. Installation, maintenance, or repairs by unqualified personnel may void the manufacturer's warranty. See Chapter 1 of this manual for definitions of qualified personnel.

**NOTICE**

This equipment must be installed in accordance with the appropriate national and local codes of the country and/or region in which the appliance is installed. See NATIONAL CODE REQUIREMENTS in Chapter 2 of this manual for specifics.

**NOTICE TO U.S. CUSTOMERS**

This equipment is to be installed in compliance with the basic plumbing code of the Building Officials and Code Administrators International, Inc. (BOCA) and the Food Service Sanitation Manual of the U.S. Food and Drug Administration.

**NOTICE**

Drawings and photos used in this manual are intended to illustrate operational, cleaning and technical procedures and may not conform to onsite management operational procedures.

**NOTICE TO OWNERS OF UNITS EQUIPPED WITH COMPUTERS**

**U.S.**

This device complies with Part 15 of the FCC rules. Operation is subject to the following two conditions: 1) This device may not cause harmful interference, and 2) This device must accept any interference received, including interference that may cause undesired operation. While this device is a verified Class A device, it has been shown to meet the Class B limits.

**CANADA**

This digital apparatus does not exceed the Class A or B limits for radio noise emissions as set out by the ICES-003 standard of the Canadian Department of Communications.

Cet appareil numérique n'émet pas de bruits radioélectriques dépassant les limites de classe A et B prescrites dans la norme NMB-003 édictée par le Ministre des Communications du Canada.

**⚠ DANGER**

Improper installation, adjustment, maintenance or service, and unauthorized alterations or modifications can cause property damage, injury, or death. Read the installation, operating, and service instructions thoroughly before installing or servicing this equipment. Only qualified service personnel may convert this appliance to use a gas other than that for which it was originally configured.

**⚠ DANGER**

No structural material on the fryer should be altered or removed to accommodate placement of the fryer under a hood. Questions? Call the Frymaster/Dean Service Hotline at 1-800-551-8633.

**⚠ DANGER**

Adequate means must be provided to limit the movement of this appliance without depending upon the gas line connection. Single fryers equipped with legs must be stabilized by installing anchor straps. All fryers equipped with casters must be stabilized by installing restraining chains. If a flexible gas line is used, an additional restraining cable must be connected at all times when the fryer is in use.

**⚠ DANGER**

The front ledge of the fryer is not a step! Do not stand on the fryer. Serious injury can result from slips or contact with the hot oil.

**⚠ DANGER**

Do not store or use gasoline or other flammable liquids or vapors in the vicinity of this or any other appliance.

**⚠ DANGER**

Instructions to be followed in the event the operator smells gas or otherwise detects a gas leak must be posted in a prominent location. This information can be obtained from the local gas company or gas supplier.

**⚠ DANGER**

This product contains chemicals known to the state of California to cause cancer and/or birth defects or other reproductive harm.

Operation, installation, and servicing of this product could expose you to airborne particles of glasswool or ceramic fibers, crystalline silica, and/or carbon monoxide. Inhalation of airborne particles of glasswool or ceramic fibers is known to the State of California to cause cancer. Inhalation of carbon monoxide is known to the State of California to cause birth defects or other reproductive harm.

**⚠ DANGER**

The crumb tray in fryers equipped with a filter system must be emptied into a fireproof container at the end of frying operations each day. Some food particles can spontaneously combust if left soaking in certain shortening material.

**⚠ WARNING**

Do not bang fry baskets or other utensils on the fryer's joiner strip. The strip is present to seal the joint between the fry vessels. Banging fry baskets on the strip to dislodge shortening will distort the strip, adversely affecting its fit. It is designed for a tight fit and should only be removed for cleaning.

## H50 SERIES GAS FRYERS TABLE OF CONTENTS

---

### CHAPTER 1: Service Procedures

1.1	Functional Description.....	1-1
	The Electronic Ignition System.....	1-1
	Interface Boards.....	1-2
	Thermostats.....	1-5
1.2	Accessing Fryers for Servicing.....	1-5
1.3	Cleaning the Gas Valve Vent Tube.....	1-5
1.4	Checking the Burner Manifold Gas Pressure.....	1-6
1.5	Measuring Flame Current.....	1-8
1.6	Replacing Fryer Components.....	1-8
	1.6.1 Replacing the Controller or the Controller Wiring Harness.....	1-8
	1.6.2 Replacing the Temperature Probe or High-Limit Thermostat.....	1-8
	1.6.3 Replacing the Interface Board.....	1-9
	1.6.4 Replacing an Ignition Module.....	1-9
	1.6.5 Replacing an Ignitor Assembly.....	1-10
	1.6.6 Replacing or Cleaning a Combustion Air Blower.....	1-10
	1.6.7 Replacing a Gas Valve.....	1-13
	1.6.8 Replacing a Burner Assembly.....	1-14
	1.6.9 Replacing the Frypot.....	1-15
	1.6.10 Replacing Frypot Insulation and/or Upper Burner Rails.....	1-16
1.7	Troubleshooting and Problem Isolation.....	1-21
	1.7.1 Ignition Failures.....	1-21
	1.7.2 Improper Burner Functioning.....	1-22
	1.7.3 Improper Temperature Control.....	1-24
	1.7.4 Computer-Related Problems.....	1-25
	1.7.5 Filtration Problems.....	1-26
	1.7.6 Leakage.....	1-29
	1.7.7 Basket Lift Malfunctions.....	1-29
	1.7.8 Interpretation of Digital Controller Lights.....	1-32
1.8	Troubleshooting Guide.....	1-32
	Probe Resistance Chart.....	1-37
1.9	Simplified Wiring Diagrams.....	1-38
1.10	Principal Wiring Connections.....	1-43
	1.11 Wiring Diagrams – Main.....	1-44
	1.12 Wiring Diagrams – Transformer Boxes.....	1-50
	1.13 Wiring Diagrams – Basket Lifts.....	1-52
	1.14 Wiring Diagrams – Filter Boxes.....	1-55
	1.14 Wiring Diagrams – Oil Return.....	1-56

### CHAPTER 2: Parts List

2.1	Accessories.....	2-1
-----	------------------	-----

## H50 SERIES GAS FRYERS TABLE OF CONTENTS

---

2.2	Basket Lift Assemblies and Component Parts .....	2-3
2.2.1	Bell Crank Basket Lifts .....	2-3
2.2.2	Modular Basket Lifts .....	2-5
2.3	Blower Assemblies and Associated Components .....	2-7
2.4	Burner Ignition System Components and Associated Hardware .....	2-9
2.5	Cabinet Assemblies and Component Parts .....	2-10
2.5.1	FPH150 .....	2-10
2.5.2	FPH50 Batteries .....	2-11
2.5.3	FH150 and MJH150 .....	2-13
2.5.4	MJH50 Batteries .....	2-14
2.5.5	FMH50 Batteries with Built-In Filtration .....	2-15
2.5.6	Filter Magic II Add-On .....	2-17
2.6	Casters, Legs, and Restraints .....	2-19
2.7	Component Box Assemblies and Associated Component Parts .....	2-20
2.8	Control Panel Assemblies, Flue Caps, Top Caps, and Related Components .....	2-21
2.9	Controller Assemblies .....	2-23
2.10	Door Assemblies .....	2-24
2.11	Drain System Components .....	2-25
2.11.1	Filter Magic II Square Drain Components, Standard Configuration .....	2-25
2.11.2	Filter Magic II Square Drain Components, Non-Standard Configurations .....	2-26
2.11.3	FootPrint III Square Drain Components, Standard Configuration .....	2-27
2.11.4	FootPrint III Square Drain Components, Rear Flush Configuration .....	2-28
2.11.5	FootPrint III Square Drain Components, Foodmaker Configuration .....	2-29
2.12	Drain Valves, Drain Valve Assemblies, and Associated Parts .....	2-30
2.12.1	Drain Valves and Drain Extensions .....	2-31
2.12.2	MJH50 Dual Vat (1-inch) Drain Valve Assemblies .....	2-31
2.12.3	FMH50 Dual Vat (1-inch) Drain Valve Assemblies .....	2-32
2.12.4	FMH50 Full Vat (1¼-inch) Drain Valve Assembly .....	2-33
2.12.5	FPH50 Dual Vat (1-inch X 1¼-inch) Valve Assemblies .....	2-34
2.12.6	FPH50 Full Vat (1¼-inch) Valve Assemblies .....	2-35
2.13	Filtration Systems and Component Parts (Other Than Drain Components) .....	2-36
2.13.1	Filter Magic II/Single FootPrint III Filter Pan Assembly .....	2-36
2.13.2	FootPrint III Filter Pan Assembly .....	2-37
2.13.3	FootPrint III Filter Base Assemblies .....	2-38
2.13.4	Filter Magic Oil Return Plumbing Components (Including Pump & Motors) .....	2-39
2.13.5	FootPrint III Filter Motors and Pump Plumbing Components .....	2-41
2.13.6	FootPrint III with Power Shower Oil Return Plumbing Components .....	2-43
2.13.7	FootPrint III with Rear Flush Oil Return Plumbing Components, Standard ...	2-45
2.13.8	FootPrint III with Rear Flush Oil Return Plumbing Components, KFC .....	2-47
2.13.9	FPH150-2 Oil Return Plumbing .....	2-49
2.13.10	Oil Return Handle Assembly, Filter Magic & Standard FootPrint III .....	2-51

## H50 SERIES GAS FRYERS TABLE OF CONTENTS

---

2.13.11	Power Shower Assemblies (All Systems).....	2-52
2.13.12	Oil Disposal Systems Plumbing.....	2-53
2.13.13	Assembly Wand Plumbing (Japan).....	2-55
2.13.14	Oil Disposal Wand Assembly.....	2-56
2.14	Frypot Assemblies and Component Parts.....	2-56
2.14.1	Replacement Frypots and Frypot Insulation Kits.....	2-56
2.14.2	Full Vat Frypot Assembly, Component Parts.....	2-57
2.14.3	Dual Vat Frypot Assembly, Component Parts.....	2-59
2.15	Gas Supply System Assemblies and Component Parts.....	2-61
2.15.1	FM/MJH50 Gas Manifold Assemblies.....	2-61
2.15.2	Gas Valves, Gas Lines, and Fittings.....	2-63
2.16	Probe, Probe Guard, and Thermostat.....	2-65
2.18	Relays, Transformers, Wiring Assemblies, and Related Parts.....	2-66
2.18.1	Filter Box Components.....	2-66
2.18.2	Transformer Box Components.....	2-67
2.19	Wiring Harnesses, Wiring Assemblies, and Plug Assemblies.....	2-69
2.20	Wiring Connectors and Pin Terminals.....	2-73

# H50 SERIES GAS FRYERS

## CHAPTER 1: SERVICE PROCEDURES

---

### 1.1 Functional Description

H50 Series fryers contain a welded stainless steel frypot that is directly heated by a high efficiency infrared burner system requiring approximately 43% less energy than conventional burners to cook the same volume.

Self-contained combustion chambers (referred to as “burners”) are fitted into rails attached to the sides of the frypot, one on each side. Each combustion chamber is fitted with special ceramic tiles that are heated by the burning of a forced air/gas mixture. The tiles transfer their heat to the frypot by means of infrared radiation, providing much more constant and uniform heat dispersion over the surface of the frypot than do conventional burners. Because less heat is lost to the atmosphere in the process, compared to “open-burner” designs, less fuel is required to achieve and maintain a given frypot temperature.

In full vat units, gas flow to both of the burners is regulated by one electromechanical gas valve. In dual vat units, each burner has its own valve. All fryers in this series are equipped with 24VAC gas valve systems, and all are configured with electronic ignition.

### THE ELECTRONIC IGNITION SYSTEM

An ignition module mounted in the component box or “shield” (located behind the control panel) is connected to an ignitor assembly at the burner. The ignition module performs four important functions: it provides fuse protection for the 24-volt circuit, provides an ignition spark, supplies voltage to the gas valve, and proofs the burner flame. The module contains a 4-second time delay circuit and a coil that activates the gas valve. Three types are in use. A closed-box design is used in most fryers, but in some fryers built for export the module resembles an interface board. A single dual-spark module is used on current production full-vat fryers. Two single-spark modules were used on full-vat fryers built before August 2000. All dual-vat fryers use two single-spark modules.

Inside the Ignition Module

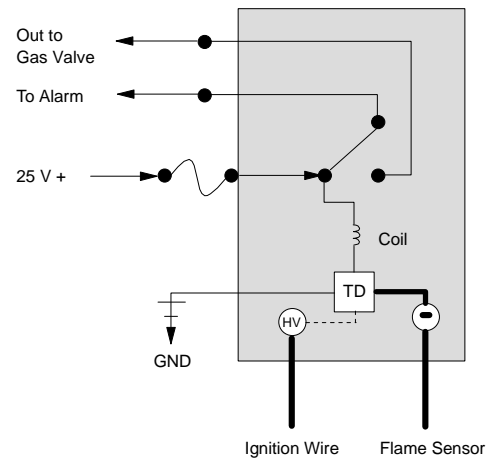

The ignitor assembly consists of a spark plug, an enrichment tube, and a flame sensor.

At start-up, the power switch is placed in the ON position, supplying approximately 12-volts DC to the heat control circuitry in the controller or computer and to one side of the heat relay coils on the interface board. If resistance in the temperature probe indicates the temperature in the frypot is below 180°F (82°C), the current flows through a melt cycle circuit where a timer switch alternately closes for 6 seconds and opens for 24 seconds. If the temperature is 180°F (82°C) or above, the current flows through a heat circuit, bypassing the timer switch. In either case, ground is supplied to

the other leg of the heat relay coils, which then close electronic switches in the 24 VAC circuit to provide current to the ignition module. Circuitry in the ignition module sends 24 VAC to the gas valve via a normally closed high-limit switch (and, in fryers with built-in filtration systems, a normally closed drain safety switch). Simultaneously, the module causes the ignitor to spark for 4 seconds to light the burner. A flame sensor verifies the burner ignition by measuring the flow of microamps through the flame. If the burner does not light (or is extinguished), current to the ignition module is cut, the gas valve closes, and the ignition module “locks out” until the power switch is turned off and then back on. A probe monitors the temperature in the frypot. When the programmed setpoint temperature is reached, resistance in the probe causes the heat cycle circuitry in the controller to cut off current flow through the heat relay. This in turn cuts off the 24 VAC to the ignition module, causing the gas valve to close.

### INTERFACE BOARDS

All fryers in this series have an interface board located in the component box located behind the control panel. The interface board provides a link between the controller/computer and the fryer’s individual components without requiring excessive wiring, and allows the controller to execute commands from one central point. The H50 Series of fryers has been in production since 1983. Consequently, servicers are likely to encounter three different interface board designs. Although the boards differ slightly in appearance, basic functioning and electrical connections are the same from one to another. In the earlier design 806-3398 interface board (used between June 1996 and July 1999), the diagnostic LEDs are arrayed in a row across the bottom of the board as shown in the left-hand illustration below. In later design 806-3398 interface boards (and in the 106-0396 interface boards that replaced them in current production fryers), the LEDs (labeled D1 though D7) are scattered around the board as shown in the right-hand illustration. The primary difference between the earlier design boards and the later design boards is the combining of the separate blower motor relay (K4) and the heat relays (K1 and K2) into a pair of replaceable relays (K2 and K3) in the latter. Also, the 106-0386 interface board has an additional fuse located in the upper right hand corner. Prior to June 1996, a board with replaceable relays very similar in appearance to the 106-0386 board was used. It is distinguished from the 106-0386 board by the absence of fuses.

**NOTE:** Although the printing on many boards indicates 2 Amp fuses, 3 Amp fuses (P/N 807-3843) must be used.

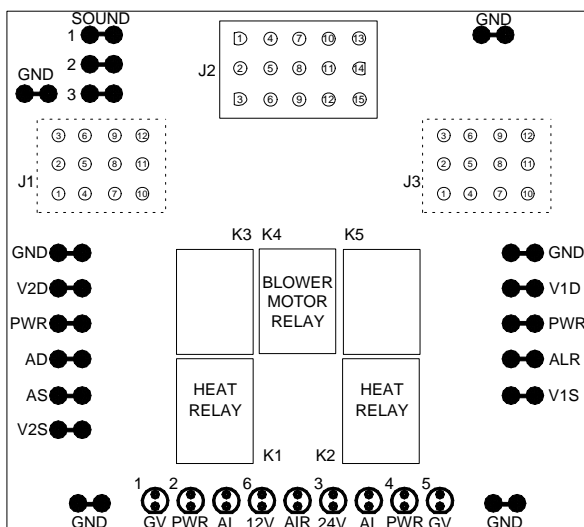

EARLIER DESIGN INTERFACE BOARD P/N 806-3398

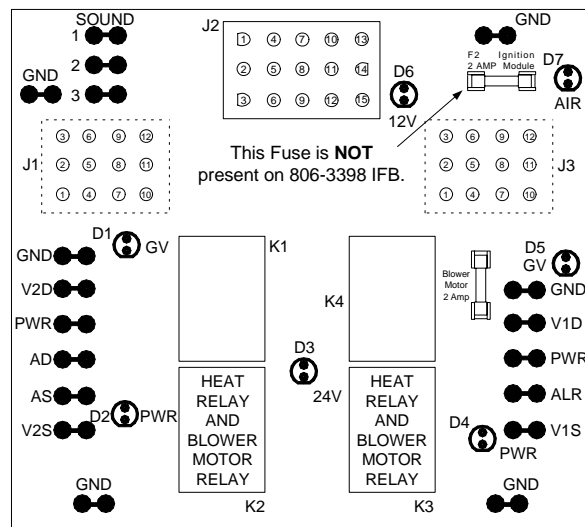

LATER DESIGN INTERFACE BOARDS P/N 806-3398 and 106-0386



FREQUENTLY USED TEST POINTS FOR INTERFACE BOARDS 806-3398 AND 106-0386			
Test	Meter Setting	Pins	Results
12VAC Power to Controller	50VAC Scale	1 and 3 on J3 or J2	12-18
24VAC Power to Right Module	50VAC Scale	8 on J3 and GROUND	22-28
24VAC Power to Left Module (if present)	50VAC Scale	8 on J1 and GROUND	22-28
120 VAC Power	250VAC Scale	11 on J3 and GROUND	110-125
120 VAC Power to Blowers	250VAC Scale	12 on J3 and GROUND	110-125
24VAC Power to Full- or Right-vat High-Limit	50VAC Scale	9 on J3 and GROUND	22-28
24VAC Power to Left High-Limit (if present)	50VAC Scale	9 on J1 and GROUND	22-28
Probe Resistance (Full- or Right-vat) *	R x 1000 OHMS	2 and 6 on J3 or 13 and 14 on J2	**
Probe Resistance (Left - if present) *	R x 1000 OHMS	2 and 6 on J1 or 14 and 15 on J2	**
Probe Isolation	R x 1000 OHMS	6 on J1 or J3 and GROUND	***
High-Limit Continuity (Full- or Right-vat)	R x 1 OHM	9 on J3 and Wire 13C on Gas Valve	0
High-Limit Continuity (Left - if present)	R x 1 OHM	9 on J1 and Wire 12C on Gas Valve	0
* Disconnect 15-pin harness from controller before testing probe circuit.			
** See Probe Resistance Chart at end of chapter.			
*** 5 mega-Ohms or greater.			

These standard interface boards are also used in a number of fryer types besides the H50 Series. **The information contained in this section applies to H50 Series applications ONLY.**

Earlier design 806-3398 boards (used from June 1996 through July 1999) contain two heat relays (K1 and K2) that switch 24VAC to the ignition and gas valve circuits when the computer/controller heat logic circuit calls for heat. Relay K4 switches 120VAC to the blower motor when either K1 or K2 closes. The relays on these boards are soldered on – if one fails, the whole board must be replaced.

The later design 806-3398 (and 106-0386 boards that replaced them in current production fryers) have only two relays. In this design, K2 and K3 are double-pole-double throw (dpdt) relays that supply 24VAC to the ignition and gas valve circuits, as well as 120VAC to the blower motor. The relays on this board plug into sockets. If a relay fails, that relay can be replaced.

The tables below identify the diagnostic LEDs and their meaning.

EARLIER DESIGN INTERFACE BOARD LED DIAGNOSTIC LIGHTS	
<b>12V</b>	Indicates 12 VAC from transformer
<b>24V</b>	Indicates 24 VAC from transformer
<b>GV</b>	Indicates 24 VAC to gas valve (left or right)
<b>PWR</b>	Indicates 24 VAC to module (left or right)
<b>AL</b>	Indicates module lock-out (left or right)
<b>AIR</b>	CE and Japanese units only: air switch closed

LATER DESIGN INTERFACE BOARD LED DIAGNOSTIC LIGHTS	
<b>D1</b>	24 VAC to left gas valve (dual vat only)
<b>D2</b>	24 VAC to left ignition module
<b>D3</b>	24 VAC from transformer
<b>D4</b>	24 VAC to right ignition module
<b>D5</b>	24 VAC to gas valve (right valve if dual vat)
<b>D6</b>	12 VAC from transformer
<b>D7</b>	CE and Japanese units only: air switch closed

# INTERFACE BOARD

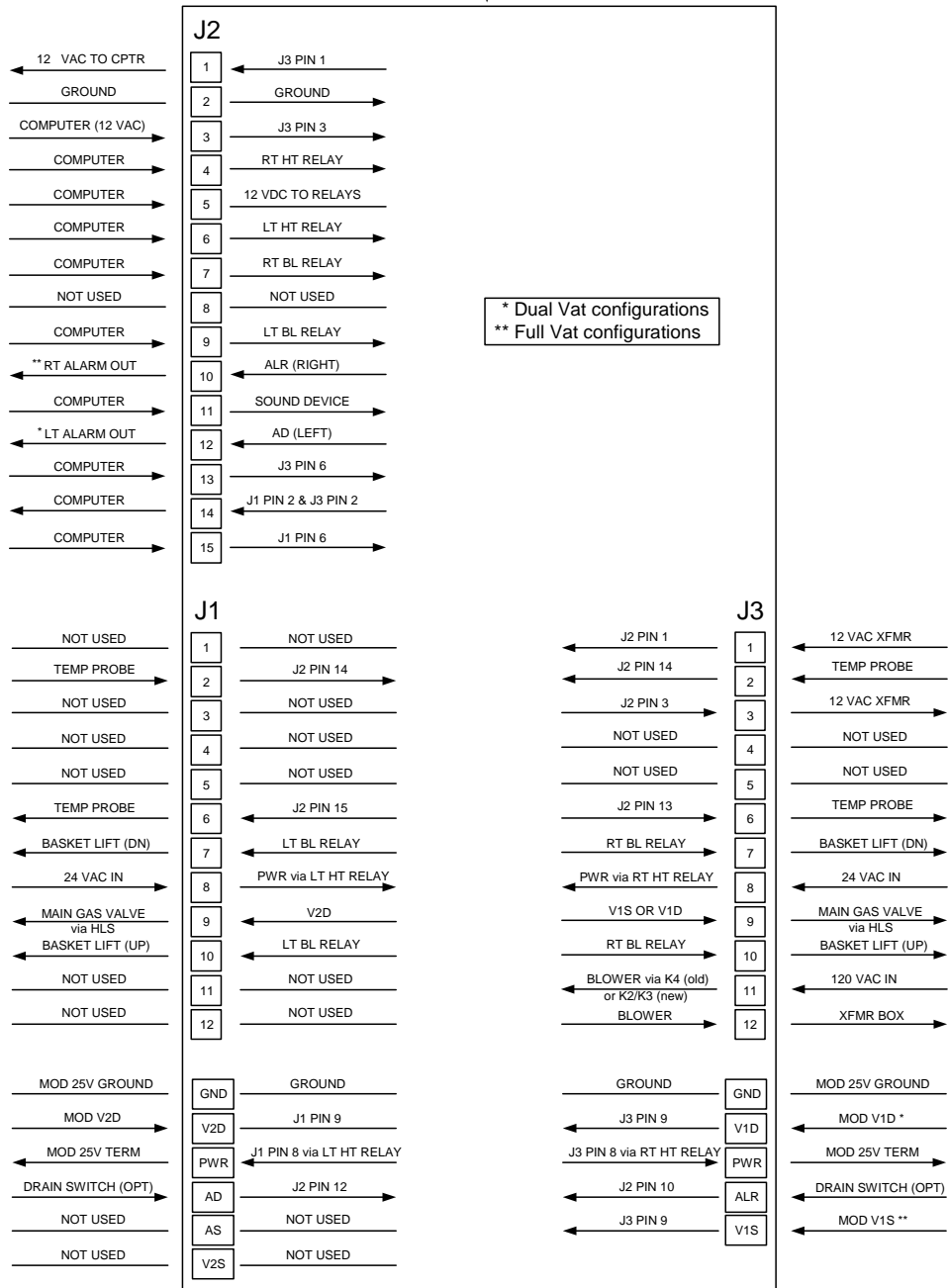

LEFT VAT

FULL OR RIGHT VAT

## CURRENT FLOW THROUGH INTERFACE BOARDS 806-3398 AND 106-0386 (H50 APPLICATION)

## THERMOSTATS

All fryers in the H50 Series have *temperature probes* located on the front centerline of each frypot. (Dual-vat frypots have two probes, one in each vat.) In this type thermostat, the probe resistance varies directly with the temperature. That is, as the temperature rises, so does resistance, at a rate of approximately 2 ohms for every 1° F. Circuitry in the controller monitors the probe resistance and controls burner firing when the resistance exceeds or falls below programmed temperatures (setpoints). The temperatures are programmed by means of a keypad on the face of the controller.

H50 Series fryers are also equipped with a *high-limit thermostat*. In the event that the fryer fails to properly control the oil temperature, the high-limit thermostat prevents the fryer from overheating to the flash point. The high-limit thermostat acts as a normally closed power switch that opens when exposed to temperatures above 425°F to 450°F (218°C to 232°C). The different types of thermostats have different part numbers for CE and Non-CE models, and are not interchangeable.

### 1.2 Accessing Fryers for Servicing

 **DANGER**

**Moving a fryer filled with cooking oil may cause spilling or splattering of the hot liquid. Drain the fryer before attempting to relocate a fryer for servicing.**

1. Shut off the gas supply to the unit. Unplug the power cords. Disconnect the unit from the gas supply.
2. Remove any attached restraining devices.
3. Relocate the fryer for service accessibility.
4. After servicing is complete, reconnect the unit to the gas supply, reattach restraining devices, and plug in the electrical cords.

### 1.3 Cleaning the Gas Valve Vent Tube

1. Set the fryer power switch and the gas valve to the OFF position.
2. Carefully unscrew the vent tube from the gas valve. **NOTE:** The vent tube may be straightened for ease in removal.
3. Pass a piece of ordinary binding wire (.052 inch diameter) through the tube to remove any obstruction.
4. Remove the wire and blow through the tube to ensure it is clear.
5. Reinstall the tube and bend it so that the opening is pointing downward.

## 1.4 Checking the Burner Manifold Gas Pressure

1. **On non-CE fryers**, ensure that the gas valve knob is in the OFF position.

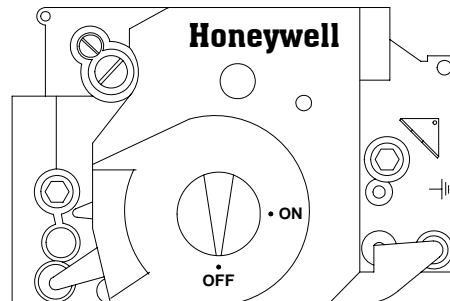

2. Remove the pressure tap plug from the gas valve assembly.

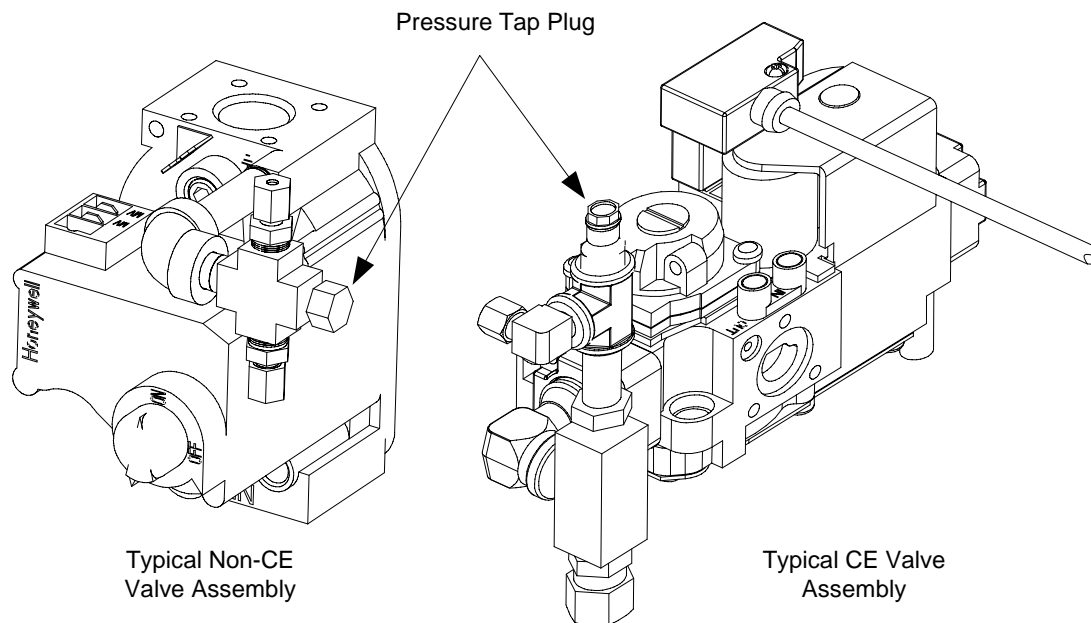

2. Insert the fitting for a gas pressure-measuring device into the pressure tap hole.
3. **On non-CE fryers only**, place the gas valve in the ON position.
4. Place the fryer power switch in the ON position. When the burner has lit and burned steadily for at least one minute, compare the gas pressure reading to the pressure for the corresponding gas in the appropriate table found on the following page. The tables list the burner manifold gas pressures for each of the gas types that can be used with this equipment.

CE Standard Burner Manifold Gas Pressures for Fryers Manufactured After April 1999		
Gas	Pressure (mbar)	
	Single Vat	Dual Vat
Natural Gas Lacq (G20) under 20 mbar	7	7
Natural Gas Gronique* (G25) under 25 mbar	10	10
Natural Gas Gronique (G25) under 20 mbar	10	10
Butane/Propane (G30) at 28/30 or 50 mbar	17	17
Propane (G31) under 37 or 50 mbar	20	20

\* Belgian G25 = 7,0 mbar (single or dual)

CE Standard Burner Manifold Gas Pressures for Fryers Manufactured Through April 1999		
Gas	Pressure (mbar)	
	Single Vat	Dual Vat
Natural Gas Lacq (G20) under 20 mbar	7	6,5
Natural Gas Gronique* (G25) under 25 mbar	10	9
Natural Gas Gronique (G25) under 20 mbar	10	9
Butane (G30) at 28/30 or 50 mbar	17	16,5
Propane (G31) under 37 or 50 mbar	20,2	18,5

\* Belgian G25 = 7,0 mbar (single) or 6,5 (dual)

Non-CE Standard Burner Manifold Gas Pressures	
Gas	Pressure
Natural	3" W.C. 0.73 kPa
Propane	8.25" W.C. 2.5 kPa

- To adjust the burner gas pressure, remove the cap from the gas valve regulator and adjust to the correct pressure.

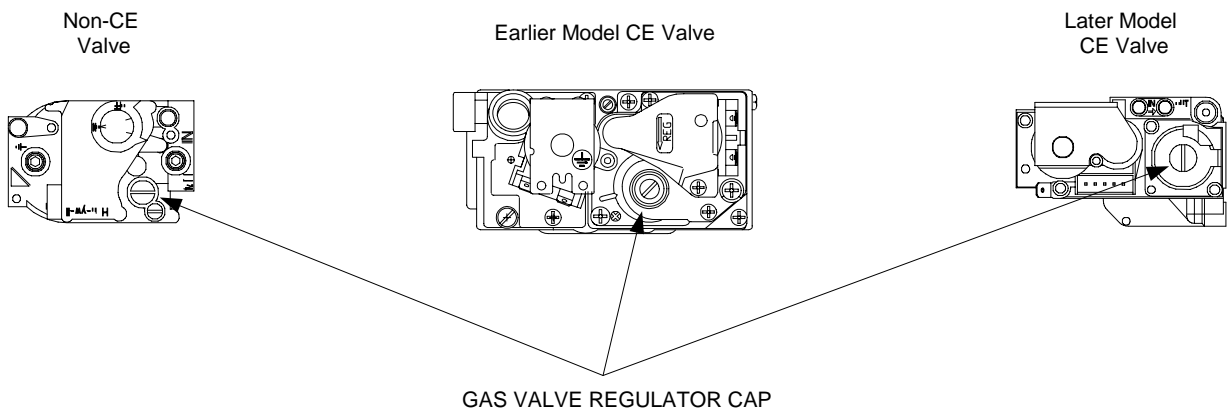

- Place the fryer power switch (and the gas valve in non-CE fryers) in the OFF position. Remove the fitting from the pressure tap hole and reinstall the pressure tap plug.

## 1.5 Measuring Flame Current

When the burner flame is properly adjusted, it will produce a current between 2.5  $\mu\text{A}$  and 3.5  $\mu\text{A}$ . Flame current is measured by placing a *microamp* (not milliamp) meter in series with the sensing wire on the ignitor. This is accomplished as follows:

1. Place the fryer power switch in the OFF position.
2. Disconnect the sensing wire from one of the burner ignitors and connect it to the positive lead of the meter. Connect the negative lead of the meter to the terminal from which the sensing wire was removed.
3. Place the fryer power switch in the ON position to light the burners. Wait at least one minute after the frypot temperature reaches 200°F (93°C) before checking the reading. **NOTE:** The closer the unit is to normal operating temperature, the more accurate the reading will be.

## 1.6 Replacing Fryer Components

### 1.6.1 Replacing the Controller or the Controller Wiring Harness

1. Disconnect the fryer from the electrical supply.
2. Remove the two screws in the upper corners of the control panel and swing the panel open from the top, allowing it to rest on its hinge tabs.
3. Disconnect the wiring harness from the back of the controller and, if replacing the harness, disconnect it from the interface board.
4. Disconnect the ground wire from the controller, and remove the controller by lifting it from the hinge slots in the control panel frame.
5. Reverse the procedure to install a new controller or wiring harness. **NOTE:** Ensure that the ferrite bead (black ring) in the harness is at the controller end.

### 1.6.2 Replacing the Temperature Probe or High-Limit Thermostat

1. Disconnect the fryer from the electrical supply.
2. Drain cooking oil below the level of the probe or thermostat.
3. Remove the screws from the upper corners of the control panel and swing the panel open from the top, allowing it to rest on its hinge tabs.
4. Unplug the controller wiring harness from the back of the controller.
5. Remove the controller by lifting it from the hinge slots in the control panel frame.
6. If the fryer has a built-in filtration system, loosen the bolt securing the oil return handle to the oil return operating rod.

7. Disconnect the ignition cables from the ignitors by grasping the boots and gently pulling toward you.
8. Remove the component box mounting screws.
9. Rotate the top of the component box out of the frame and carefully pull it out enough to disconnect the wiring harness plug(s) from the back of the box.
10. Remove the box and set it aside.
11. Make a note of the location of the existing wires. Using a pin-pusher, disconnect the temperature probe wires (or high-limit thermostat wires) from the connector plug.
12. Unscrew and remove the temperature probe (or high limit thermostat) from the frypot.
13. Apply Loctite<sup>®</sup> PST56765 pipe thread sealant or equivalent to the replacement part threads.
14. Screw the replacement part into the frypot and torque to 180 inch-pounds.
15. Connect the wires from the new component to the connector plug, referring to the note made in step 11.
16. Reverse steps 1 through 9 to complete the procedure.

### **1.6.3 Replacing the Interface Board**

1. Remove the component box per steps 1 through 10 of Section 1.6.2.
2. Unplug the controller wiring harness from the interface board.
3. Disconnect the wires attached to the interface board, marking or making a note of the wires and terminals to facilitate reconnection.
4. Remove the nuts at each corner of the interface board and pull it from the studs.
5. Reverse the procedure to install the replacement board, being sure to reinstall the spacers behind the interface board.

### **1.6.4 Replacing an Ignition Module**

1. Disconnect the fryer from the electrical supply.
2. Remove the screws from the upper corners of the control panel and swing the panel open from the top, allowing it to rest on its hinge tabs.
3. Disconnect the wires from the ignition module, marking or making a note of the wires and terminals to facilitate reconnection.
4. Remove the four ignition module screws and pull the module from the component box.

5. Reverse the procedure to install the replacement module.

### 1.6.5 Replacing an Ignitor Assembly



**DANGER**

**Drain the frypot or remove the handle from the drain valve before proceeding further.**

1. Disconnect the fryer from the electrical supply.
2. Disconnect the ignition cable from the ignitor by grasping the boot and gently pulling toward you.
3. Remove the sheet metal screw securing the ignitor to the mounting plate and pull the ignitor from the fryer.
4. Reverse the procedure to install the replacement ignitor.

### 1.6.6 Replacing or Cleaning a Combustion Air Blower

A sheet metal shield or shield assembly prevents inadvertent access to the blower assembly. The specific design varies depending upon the particular configuration of the fryer and the country for which manufactured, but in all cases, the shield is attached to the cabinet framing by sheet metal screws. Remove the screws that secure the shield or shield assembly to the cabinet framing and pull the shield out of the fryer to expose the combustion air blower assembly.

1. Disconnect the blower wiring harness and remove the blower assembly mounting nuts.

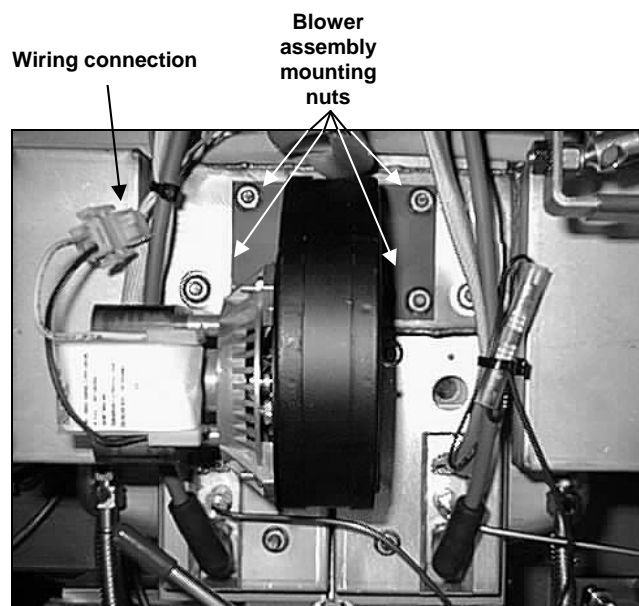

2. Remove the three fasteners that secure the blower motor assembly to the blower housing, and separate the two components.



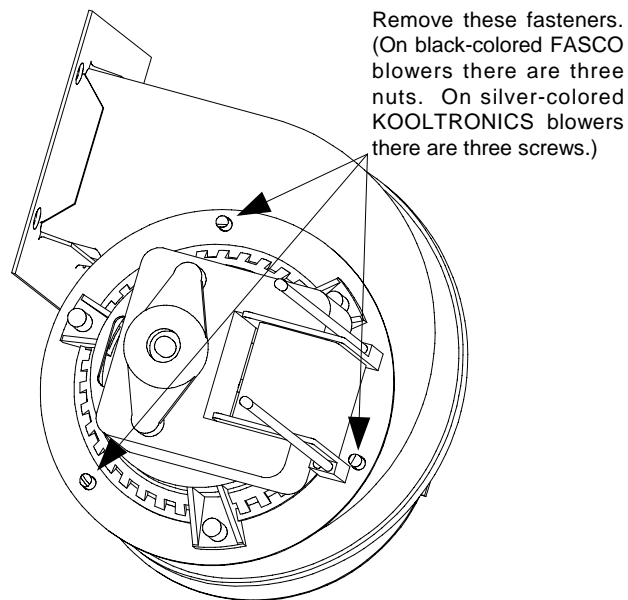

3. Wrap the motor with plastic wrap to prevent water from entering it. Spray degreaser or detergent on the blower wheel and the blower housing. Allow it to soak for five minutes. Rinse the wheel and housing with hot tap water, then dry with a clean cloth.

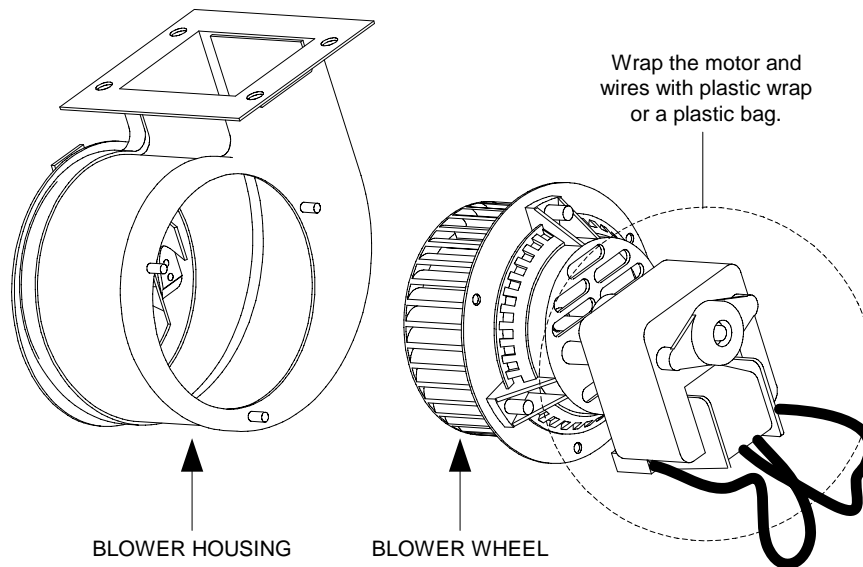

4. Remove the plastic wrap from the blower motor assembly. Reassemble the blower motor assembly and blower housing. Reinstall the blower assembly in the fryer.
5. Reinstall the blower shield or shield assembly.
6. Light the fryer in accordance with the procedure described in Chapter 3, Section 3.1 of the H50 Series Installation and Operation Manual (P/N 819-5000).
7. After the burners have been lit for at least 90 seconds, observe the flames through the burner viewing ports located on each side of the combustion air blower.

Left Viewing Port is Behind Motor  
(NOTE: Blower shield omitted for clarity.)

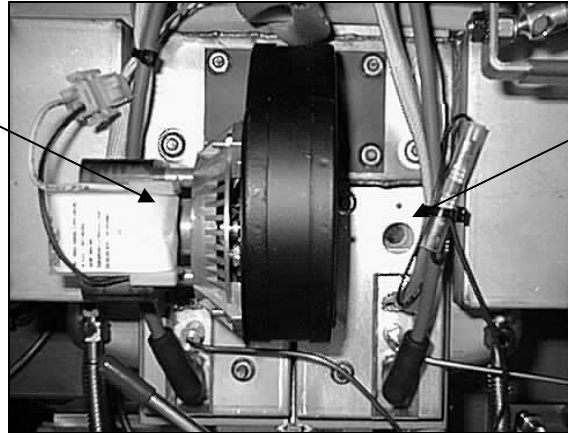

Right Viewing Port

The air/gas mixture is properly adjusted when the burner manifold pressure is in accordance with the applicable table on page 1-7 and the burners display a bright orange-red glow. If a blue flame is observed, or if there are dark spots on a burner face, the air/gas mixture requires adjustment.

### Adjusting Air/Gas Mixture Non-CE Units and CE Units Built After April 1999

On the side of the blower housing opposite the motor is a plate with one or two locking nuts. Loosen the nut(s) enough to allow the plate to be moved, then adjust the position of the plate to open or close the air intake opening until a bright orange-red glow is obtained. Carefully hold the plate in position and tighten the locking nut(s).

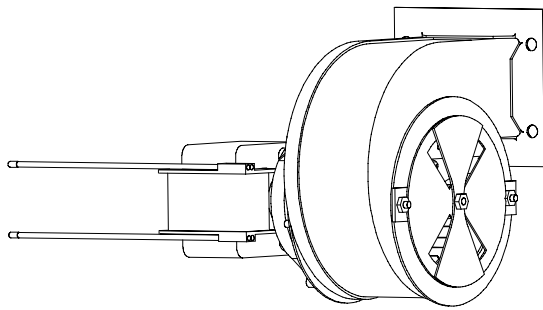

TYPICAL NON-CE BLOWER ASSEMBLY

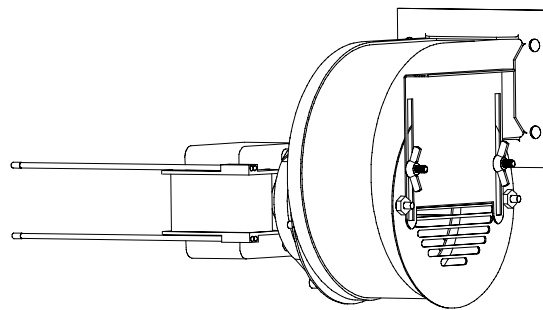

TYPICAL CE BLOWER ASSEMBLY  
ON UNITS BUILT AFTER APRIL 1999

### Adjusting Air/Gas Mixture CE Units Built Through April 1999

CE units built through April 1999 are equipped with a shield assembly in front of the blowers. An air shutter plate on the face of the shield assembly regulates the amount of airflow to the blower intake. To adjust the shutter plate, loosen the locking screws and slide the shutter to the left or right as necessary to obtain a bright orange-red glow. Carefully hold the shutter plate in position and tighten the locking screws.

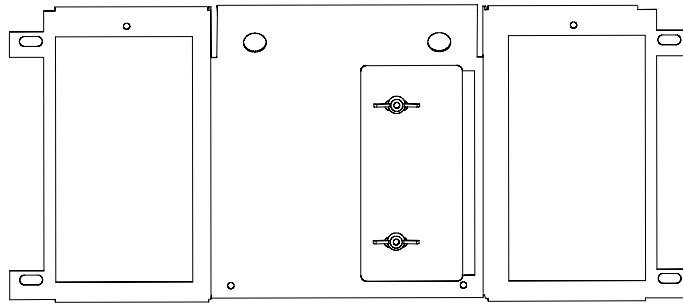

TYPICAL CE BLOWER SHIELD ASSEMBLY  
ON UNITS BUILT THROUGH APRIL 1999

#### 1.6.7 Replacing a Gas Valve



**DANGER**

**Drain the frypot or remove the handle from the drain valve before proceeding further.**

1. Disconnect fryer from electrical and gas supplies.
2. Disconnect the wires from the gas valve terminal block, marking each wire to facilitate its reconnection.
3. Remove the vent tube and the enrichment tube fitting from the valve.
4. Disconnect the flexible gas line(s).
5. Carefully unscrew the valve from the manifold. NOTE: Some models may have the valve attached to the manifold by means of a pipe union. In such cases, remove the valve by uncoupling the union.
6. Remove all fittings from the old gas valve and install them on the replacement valve, using Loctite<sup>®</sup> PST56765 or equivalent pipe thread sealant.
7. Apply Loctite<sup>®</sup> PST 56765 or equivalent pipe thread sealant to the threads of the manifold (or union). Reverse steps 1-5 to install the replacement gas valve.

## 1.6.8 Replacing a Burner Assembly



**Drain the frypot or remove the handle from the drain valve before proceeding further.**

1. Disconnect the unit from the electrical and gas supplies.
2. Remove the combustion air blower per the procedure found in Section 1.6.6.
3. Remove the four nuts from the air plenum assembly and pull the assembly straight out toward you until it clears the burner tubes.  
**NOTE:** On a dual vat fryer, it will be necessary to remove the drain valve handles before the plenum can be removed.
4. Disconnect the ignition cables from the ignitors by grasping their boots and pulling toward you.
5. Disconnect the gas lines and enrichment tubes from the burner orifices and ignitor assemblies.
6. Remove the four ¼” (6mm) nuts securing the outer front covers to the frypot assembly.
7. Remove the sheet metal screws at the top of the outer front covers and pull the covers straight out toward you until clear of the mounting studs.
8. Remove the washers and tubular spacers from the mounting studs, then pull the inner covers straight out toward you until clear of the mounting studs.
9. Grasp the burner firmly and pull it toward you until it clears the burner channels, taking care not to damage the ceramic tiles in the process.
10. Clean all debris from the burner channels and combustion area.
11. Inspect the upper and lower burner rails for cracked or burned-out welds.
  - a. If the welds in the lower rail are cracked or burned out, the frypot must be replaced. Refer to Section 1.6.9 for procedure.
  - b. If the welds in the upper rail are cracked or burned out, the upper rail must be replaced. Refer to Section 1.6.10 for procedure.
12. Place a new insulating strip along the top, rear, and bottom edge of the burner and carefully slide it straight into the rails.  
**NOTE:** Use P/N 826-0931 for full vat frypots and P/N 826-0932 for dual vat frypots.
13. Reverse steps 1 through 9 to reassemble the components.
14. Fill the frypot with oil. Turn the fryer on, turn off or bypass the melt cycle, and operate the unit for at least 10 minutes.

15. Examine the burner flame. The color and intensity on both sides should be the same.
16. Use an inspection mirror to check for leaks in areas that cannot be directly observed.
17. If a leak is detected, tighten all the lower insulation retainer nuts, allow the frypot to run for five additional minutes, and repeat steps 15 and 16.
18. If the leak persists, use a rubber hammer and a small block of wood to tap the corners of the lower combustion chamber insulation retainers. Repeat steps 15 through 17. **Repeat this step until no leakage is detected.**

### **1.6.9 Replacing the Frypot**

1. Drain cooking oil from the frypot.
2. Remove all accessories, e.g., frypot covers, basket lift arms, etc. from the fryer.
4. Disconnect the fryer from gas and electrical supplies.
5. Remove the screws from the topcap above the control panel and lift it up and off the fryer(s).
6. Remove the screws from the upper left and right corners of the control panel. Open the panel, disconnect the controller wiring harness and ground wire. Remove the controller from the fryer.
7. Disconnect the ignition wires from the ignitor plugs by grasping their boots and pulling toward you.
8. Remove the screws securing the component box to the frame, and then rotate the top of the box forward and out of the fryer enough to disconnect the wiring harness connector plug(s) on the rear of the box. Set the component box aside.
9. Using a pin pusher, remove the temperature probe and high-limit thermostat wires from the plug(s), marking each wire to facilitate re-assembly.
10. On fryers with built-in filtration, remove the cover from the safety drain switch, disconnect the wires from the switch, and pull them out of the switch box.
11. On fryers with built-in filtration, remove the section(s) of square drain from the drain valve(s) of the frypot to be removed.
12. Disconnect the gas lines and enrichment tubes from the burner orifices and ignitor assemblies.
13. Remove the frypot hold down bracket.
14. Remove the screws from the flue cap sides and back and lift it clear of the fryer(s).
15. On units equipped with built-in filtration, disconnect the oil return line(s) from the frypot to be removed.

16. Carefully lift the frypot from the fryer cabinet.
17. Remove the drain valve(s), temperature probe(s), high-limit thermostat(s), and ignitor assemblies. Inspect each of these components carefully and install them in the replacement frypot if they are in serviceable condition. Use Loctite<sup>®</sup> PST56765 sealant or equivalent on component threads.  
  
**NOTE:** Some servicers, based upon their experience, recommend that probes and thermostats be replaced whenever a frypot is replaced, but this remains the customer's decision.
18. Reverse steps 1-16 to reassemble fryer.
19. Perform steps 14 through 18 of Section 1.6.8 to ensure that there are no leaks in the burner insulation.

 **CAUTION**

**Before installing the temperature probe, high-limit thermostat, and drain valve on the replacement frypot, clean their threads and apply Loctite<sup>®</sup> PST56765 thread sealant or equivalent.**

#### **1.6.10 Replacing Frypot Insulation and/or Upper Burner Rails**

**NOTE:** Replacing the burner rails requires completely tearing down the frypot and installing new frypot insulation. Refer to the frypot exploded view on page 1-18 for component identification. A CD containing a PowerPoint presentation detailing the procedure is also available (P/N 819-5805).

1. Remove the frypot per Section 1.6.9.
2. Remove the burner assemblies (1).
3. Remove insulation retainers and blanket insulation (2).
4. Remove the upper oil zone insulation bracket and upper oil zone insulation (3).
5. Remove the plenum (4).
6. Remove the front lower combustion chamber insulation retainer and insulation (5), and the front lower combustion chamber inner insulation retainer and insulation (6).

**NOTE:** Full vat units have two-piece insulation retainer and insulation components. Dual vat units have one-piece components.

7. Remove the upper combustion chamber insulation retainer and insulation (7).
8. Remove the inner upper combustion chamber insulation retainer and insulation (8).
9. Remove the rear lower combustion chamber retainers, back, and insulation (9).

**NOTE:** Full vat units have two-piece backs and four retainers. Dual vat units have one-piece backs and two retainers.

10. Remove the flue assembly (10).
11. Remove the upper burner rails (11).

**NOTE:** For the following steps, refer to the frypot exploded view on page 3-19 for component identification.

12. Remove any residual insulation, sealant, and/or oil from the exterior of the frypot.
13. Place the “L” shaped pieces of combustion chamber insulation (1) in the front and rear corners of both upper rail-retaining slots.
14. Use a small amount of furnace or muffler repair cement to seal the gaps at each end of both lower rails. (See inset, page 3-19.)
15. Install the upper burner rails (2) with the heat deflectors slanting toward the rear of the frypot. The rails will cover the “L” shaped pieces of combustion chamber insulation previously installed.
16. Place the upper inner combustion chamber insulation and insulation retainers (3) on the top two studs on each side of the front of the frypot and secure with ¼-20 washer-nuts. (It is normal for the retainers to slice off the overhanging insulation.)
17. Place the lower rear combustion chamber insulation (4) on the lower four studs at the rear of the frypot.
18. Place one 1.625-inch tubular spacer (5) on each of the flue assembly (upper) studs at the rear of the frypot.

**NOTE:** There are three different sizes of spacers. Verify the size to ensure the correct spacers are installed.

19. Press the flue assembly (6) over the burner rails. It may be necessary to use a rubber mallet or screwdriver to align the components. Use four ¼-20 washer nuts to secure the flue assembly. **Do not tighten the retainer nuts at this point. They should be finger-tight only.**

**NOTE:** The flue edge will cover one to two inches of the lower insulation.

20. Install the lower rear combustion chamber back(s) and retainer(s) (7) with the flanged edge(s) against the flue. Secure with ¼-20 washer nuts.

**NOTE:** Full vat units have two-piece backs and four retainers. Dual vat units come with one-piece backs and only two retainers.

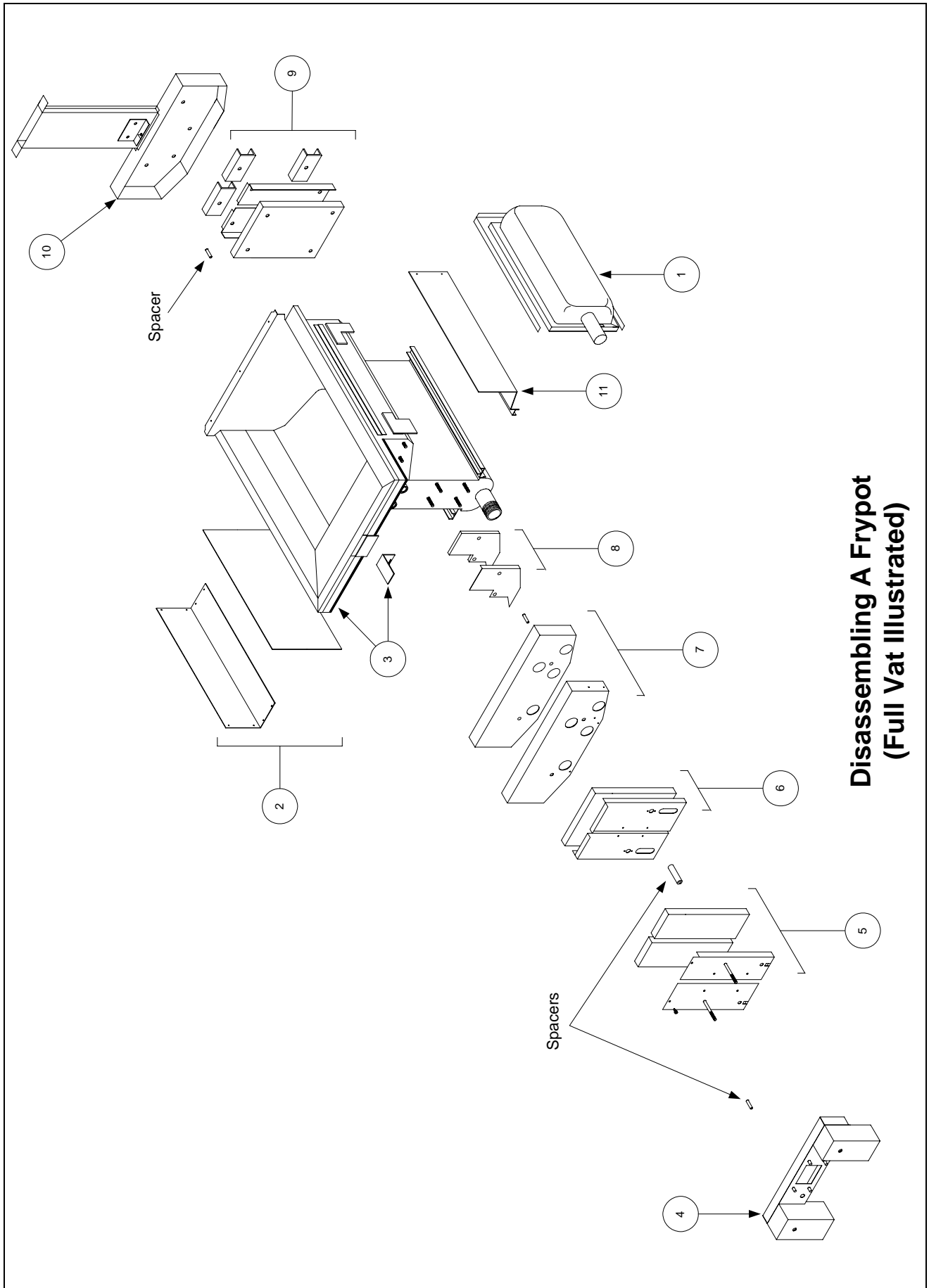

**Disassembling A Frypot  
(Full Vat Illustrated)**



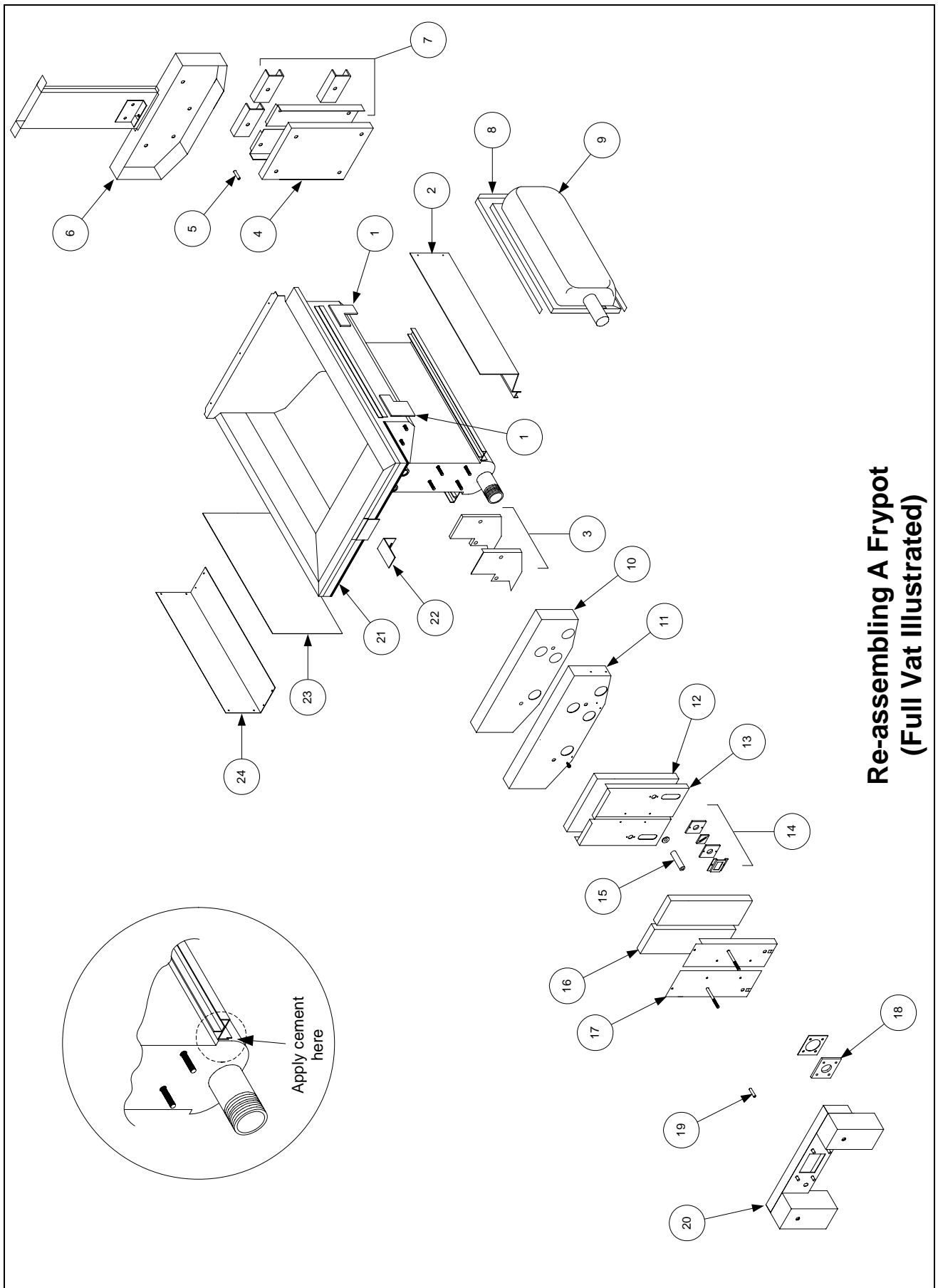

**Re-assembling A Frypot  
(Full Vat Illustrated)**

21. Insert the burners (9) into the rails to ensure the rail spacing and alignment are correct. The burner should slide freely into and out of the rails. The upper rail can be bent slightly to increase or decrease tension on the burner, and the edges of the slot can be closed or opened slightly to best fit the burner frame.
22. Carefully wrap a strip of burner insulation (8) tightly around the rear and sides of the burner frame (9), with the glass-tape side of the strip on the outside. **Do not use duct tape or adhesive to secure the strip to the burner frame.**
23. Align the burner to the burner rails while maintaining tension on the insulation strip. Insert the burner at a slight angle and begin pushing the burner slowly into the rails until it contacts the rear combustion chamber. The fit should be snug, but not excessively tight.
24. Verify that the burners are flush with the front edge of the burner rails. Remove the excess burner insulation by cutting with a knife or diagonal pliers. **Do not try to tear the insulation!**
25. Insert the upper front insulation (10) into its retainer (11), making sure that the holes in each piece are aligned with one another. Install the assembly with the insulation side toward the frypot and secure with ¼-20 washer-nuts. **Do not over tighten.**
26. Place a washer on each of the four lower studs on the front of the frypot. Install the lower inner front insulation (12) with the rectangular openings toward the drain valve nipple. Install the lower inner front insulation retainer(s) (13).  
  
**NOTE:** Full vat units have a two-piece insulation retainer. Dual vat units have a one-piece retainer.
27. If necessary, replace the sight-glasses and insulation (14).
28. Place one washer and one 1.888-inch spacer (15) on each stud.  
  
**NOTE:** There are three different sizes of spacers. Verify the size to ensure the correct spacers are installed.
29. Insert the front lower insulation (16) into the front lower insulation retainer(s) (17) and install assembly on frypot. Secure with ¼-20 washer-nuts. If frypot uses two retainers, connect them together with two ¼” self-tapping screws.  
  
**NOTE:** Full vat units have a two-piece insulation retainer and two pieces of insulation. Dual vat units have one-piece components.
30. Return to the rear of the frypot and fully tighten all washer-nuts.
31. Remove and replace the plenum gaskets (18).
32. Place a 0.938-inch spacer (19) on the plenum-mounting studs, and mount the plenum (20). Ensure the gaskets are clear of the burner tubes by pulling the plenum back slightly. Place a washer on each stud and secure plenum with ¼-20 locknuts.

33. Install the upper oil-zone insulation (21) by pressing it under the upper combustion chamber metalwork. Secure the insulation with the bracket (22) and ¼” self-tapping screws.
34. Install the upper burner rail blanket insulation (23). Position any excess insulation toward the top of the frypot. Avoid overhang past the bottom of the upper burner rail. Overhang in this area will make future burner replacement more difficult.
35. Cover the insulation with the insulation retainer (24), and secure with ¼” self-tapping screws.
36. Reinstall probes, drain valves, high-limit thermostats and other pipefittings using Loctite® PST56765 sealant or equivalent on their threads.

## **1.7 Troubleshooting and Problem Isolation**

Because it is not feasible to attempt to include in this manual every conceivable problem or trouble condition that might be encountered, this section is intended to provide technicians with a general knowledge of the broad problem categories associated with this equipment, and the probable causes of each. With this knowledge, the technician should be able to isolate and correct any problem encountered.

Problems you are likely to encounter can be grouped into seven broad categories:

1. Ignition failures
2. Improper burner functioning
3. Improper temperature control
4. Computer-related problems
5. Filtration problems
6. Leakage
7. Basket lift malfunctions.

The probable causes of each category are discussed in the following sections. A series of Troubleshooting Guides is also included at the end of the chapter to assist in identifying some of the more common problems.

### **1.7.1 Ignition Failures**

Ignition failure occurs when the ignition module fails to sense a flame within the 4-second time delay period and locks out. When this happens, the module sends 24 VAC through the interface board alarm circuit to the controller/computer.

Analog controllers indicate ignition failure by illuminating the heat light and trouble light simultaneously. Digital, Computer Magic III, and Basket Lift Timer controls display “H E L P.”

The three primary reasons for ignition failure, listed in order of probability, are:

1. Problems related to the gas and/or electrical power supplies
2. Problems related to the electronic circuits
3. Problems related to the gas valve.

## PROBLEMS RELATED TO THE GAS AND/OR ELECTRICAL POWER SUPPLIES

The main indicators of this are that an entire battery of fryers fails to light and/or there are no indicator lights illuminated on the fryer experiencing ignition failure. Verify that the quick disconnect fitting is properly connected, the fryer is plugged in, the main gas supply valve is open, and the circuit breaker for the fryer electrical supply is not tripped.

## PROBLEMS RELATED TO THE ELECTRONIC CIRCUITS

If gas and electrical power are being supplied to the fryer, the next most likely cause of ignition failure is a problem in the 24 VAC circuit. If the fryer is equipped with a built-in filtration system, first verify that the drain valve is fully closed. (The valve is attached to a microswitch that must be closed for power to reach the gas valve. Often, although the valve handle appears to be in the closed position, the microswitch is still open.) If the valve is fully closed, or the fryer does not have a built-in filtration system, refer to the troubleshooting guides **TROUBLESHOOTING THE 24 VAC CIRCUIT**.

Some typical causes of ignition failure in this category include a defective sensing wire in the ignitor assembly, a defective module, a defective ignition wire, and a defective ignitor.

Occasionally you may encounter an ignition failure situation in which all components appear to be serviceable and the microamp reading is within specification, but the unit nevertheless goes into ignition failure during operation. The probable cause in this case is an intermittent failure of an ignition module. When the unit is opened up for troubleshooting, the module cools down enough to operate correctly, but when the unit is again closed up and placed back into service the module heats up and fails.

## PROBLEMS RELATED TO THE GAS VALVE

If the problem is not in the 24 VAC circuit, it is most likely in the gas valve itself, but before replacing the gas valve refer to **TROUBLE SHOOTING THE GAS VALVE**.

### 1.7.2 Improper Burner Functioning

With problems in this category, the burner ignites but exhibits abnormal characteristics such as “popping,” dark spots on the burner ceramics, fluctuating flame intensity, and flames shooting out of the flue.

“*Popping*” indicates delayed ignition. In this condition, the main gas valve is opening but the burner is not immediately lighting. When ignition does take place, the excess gas “explodes” into flame, rather than smoothly igniting.

The primary causes of popping are:

- Incorrect or fluctuating gas pressure
- A defective or incorrectly adjusted combustion air blower
- Inadequate make-up air
- Heat damage to the controller or ignition module
- A cracked ignitor or broken ignition wire
- A defective ignition module
- Cracked burner tile (this typically causes a very loud pop)

If popping occurs only during peak operating hours, the problem may be incorrect or fluctuating gas pressure. Verify that the incoming gas pressure (pressure to the gas valve) is in accordance with the appropriate table below, and that the pressure remains constant throughout all hours of usage. Refer to **Check Burner Manifold Pressure** in the section of 1.4 for the procedure for checking the pressure of gas supplied to the burner.

CE Standard for Incoming Gas Pressures for Fryers Manufactured After April 1999					
Gas	Pressure (mbar) <sup>(1)</sup>	Orifice Diameter		Regulator Pressure	
		Single Vat	Dual Vat	Single Vat	Dual Vat
G20	20	2 x 3.40	2 x 3.40	7 mbar	7 mbar
G25	20 or 25	2 x 3.40	2 x 3.40	10 mbar	10 mbar
G30	28/30 or 50	2 x 2.05	2 x 2.05	17 mbar	17 mbar
G31	37 or 50	2 x 2.05	2 x 2.05	20 mbar	20 mbar

(1) mbar = 10,2 mm H<sub>2</sub>O

CE Standard for Incoming Gas Pressures for Fryers Manufactured Through April 1999					
Gas	Pressure (mbar) <sup>(1)</sup>	Orifice Diameter		Regulator Pressure	
		Single Vat	Dual Vat	Single Vat	Dual Vat
G20	20	2 x 3.40	2 x 3.40	7 mbar	7 mbar
G25	20 or 25	2 x 3.40	2 x 3.40	10 mbar	9 mbar
G30	28/30 or 50	2 x 2.05	2 x 2.05	17 mbar	16,5 mbar
G31	37 or 50	2 x 2.05	2 x 2.05	20,2 mbar	18,5 mbar

(1) mbar = 10,2 mm H<sub>2</sub>O

Non-CE Standard for Incoming Gas Pressures		
Gas	Minimum	Maximum
Natural	6" W.C.	14" W.C.
	1.49 kPa	3.48 kPa
	14.93 mbar	34.84 mbar
LP	11" W.C.	14" W.C.
	2.74 kPa	3.48 kPa
	27.37 mbar	34.84 mbar

If popping is consistent during all hours of operation, the most likely cause is an insufficient air supply. Check for “negative pressure” conditions in the kitchen area. If air is flowing into the kitchen area, this indicates that more air is being exhausted than is being replenished and the burners may be starved for air.

If the fryer’s gas and air supplies are okay, the problem is most likely with one of the electrical components. Examine the ignition module and controller for signs of melting/distortion and/or discoloration due to excessive heat build-up in the fryer. (This condition usually indicates improper flue performance.) A melted or distorted ignition module is automatically suspect and should be replaced, but unless the condition causing excessive heat is corrected, the problem is likely to recur.

Verify that the ignition wire is tightly connected at both ends and free of obvious signs of damage. Again, if damage is due to excessive heat in the fryer, that problem must also be corrected.

Check for proper operation by disconnecting the wire from the ignitor (spark plug), inserting the tip of a screw driver into the terminal, and holding it near the frame of the fryer as the power switch is placed in the ON position. A strong, blue spark should be generated for at least 4 seconds.

 <b>DANGER</b> <b>MAKE SURE YOU ARE HOLDING THE INSULATED HANDLE OF THE SCREWDRIVER  AND NOT THE BLADE. THE SPARKING CHARGE IS APPROXIMATELY 25,000  VOLTS.</b>
---

Examine the ignitor (spark plug) for any signs of cracking. A cracked ignitor must be replaced.

If all other causes have been ruled out, examine the burner tiles for any signs of cracking. If cracks are found, the burner must be replaced.

*Fluctuating flame intensity* is normally caused by either improper or fluctuating incoming gas pressure, but may also be the result of variations in the kitchen atmosphere. Verify incoming gas pressure in the same way as for “popping,” discussed in the preceding paragraphs. Variations in the kitchen atmosphere are usually caused by air conditioning and/or ventilation units. As they start and stop, the pressure in the kitchen may change from positive or neutral to negative, or vice versa. They may also cause changes in airflow patterns that may affect flame intensity.

*Dark spots on the burner tiles* are the result of an improper air/gas mixture. Adjust the combustion air blower to reduce the amount of air in the mixture to correct this problem.

*Flames shooting out of the flue* are usually an indication of negative pressure in the kitchen. Air is being sucked out of the burner enclosure and the flames are literally following the air. If negative pressure is not the cause, check for high burner manifold gas pressure in accordance with the procedure in Section 1.4.

An *excessively noisy burner*, especially with *flames visible above the flue opening*, may indicate that the gas pressure is too high, or it may simply be that the gas valve vent tube is blocked. If the incoming gas pressure is correct and the vent tube is unobstructed, the gas valve regulator is probably defective.

Occasionally a burner may apparently be operating correctly, but nevertheless the fryer has a *slow recovery rate* (the length of time required for the fryer to increase the oil temperature from 250°F to 300°F (121°C to 149°C)). The primary causes of this are an over-filled vat, a dirty or out-of-adjustment combustion air blower, low burner manifold pressure, and/or damaged burner tiles. Adding oil to the frypot during the recovery process will also cause a slow recovery rate. If these causes are ruled out, the probable cause is a misadjusted gas valve regulator. Refer to the **Check Burner Manifold Pressure** procedure Section 1.4.

### 1.7.3 Improper Temperature Control

Temperature control, including the melt cycle, is a function of several interrelated components, each of which must operate correctly. The principle component is the temperature probe. Other components include the interface board, the controller itself, and the ignition module.

Improper temperature control problems can be categorized into melt cycle problems and failure to control at setpoint problems.

#### MELT CYCLE PROBLEMS

In fryers equipped with analog controls, the melt cycle must be initiated by pressing the melt cycle switch. With all other controllers, initiation of the melt cycle is automatic. Problems may be with the controller itself, the temperature probe, or a malfunctioning heat relay on the interface board.

## FAILURE TO CONTROL AT SETPOINT

Problems in this category may be with the temperature probe, the interface board, or the controller.

### 1.7.4 Computer-Related Problems

#### COMPUTER MAGIC III FEATURES

##### SENSITIVITY OR “STRETCH AND SHRINK TIME”

Sensitivity or stretch time is a programmable feature, patented by Frymaster, which increases or decreases the cooking time countdown based on variations in the oil temperature from the set point.

The sensitivity for each product button has ten settings (0 through 9). A zero sensitivity setting will disable the feature (no change in cooking time), while a nine will provide the highest sensitivity or most change. The correct sensitivity for any product is based on the product, its density, the set point temperature, and the customer’s own requirements.

##### RECOVERY TIME

*Recovery time* is a method of measuring a fryer’s performance. Put simply, it is the time required for the fryer to increase the oil temperature from 250°F to 300°F (121°C to 149°C). This range is used as a standard since ambient kitchen temperatures can effect the test if lower ranges are used.

The Computer Magic III performs the recovery test each time the fryer warms up. An operator can view the results of the test any time the fryer is above the 300°F (149°C) point by pressing the  button and entering the code 1652. The test results will be displayed in the computer’s LED panel in minutes and seconds. The maximum acceptable recovery time for the H50 Series of fryers is two minutes and twenty-five seconds.

#### COMMON COMPUTER COMPLAINTS

Most problems concerning computers have to do with programming them. There are four common complaints. The complaints, their causes, and corrective actions are:

1. Fryer constantly displays “HI.”

Cause: Setpoint incorrect or missing.

Corrective Action: Press  1650, enter the correct setpoint using keypad, then press  to lock in the setpoint.

2. Temperature is displayed in Celsius.

Cause: Computer is programmed to display in Celsius.

Corrective Action: Press  1658.

3. Temperature is constantly displayed.

Cause: Computer is programmed for constant temperature display.

Corrective Action: Press  165L.

4. Computer times down too slowly or too quickly.

Cause: Computer is compensating for oil temperature via the sensitivity setting.

Corrective Action: Reprogram the sensitivity setting for each product in accordance with the programming instructions in the Computer Magic III Chapter of the Frymaster Fryer Controllers Operator's Manual (P/N 819-5916).

### 1.7.5 Filtration Problems

The majority of filtration problems arise from operator error. One of the most common errors is placing the filter paper on the bottom of the filter pan rather than over the filter screen.

Whenever the complaint is “the pump is running, but no oil is being filtered,” check the installation of the filter paper, including that the correct size is being used. While you are checking the filter paper, verify that the O-ring on the bottom of the filter pan is present and in good condition. A missing or worn O-ring will allow the pump to suck air and decrease its efficiency.

If the pump motor overheats, its thermal overload will trip and the motor will not start until it is reset. If the pump motor does not start, press the red reset switch located on the rear of the motor. If the pump then starts, something caused the motor to overheat. It may just be that several frypots were being filtered one after the other and the pump got hot. Letting the pump cool down for at least a half-hour is all that is required in this case. More often, the pump overheated for one of the following reasons:

- Shortening was solidified in the pan or filter lines.
- The operator attempted to filter oil or shortening that was not heated. Cold oil and shortening are thicker and cause the pump motor to work harder and overheat.

If the motor hums but the pump does not rotate, there is a blockage in the pump. Incorrectly sized or installed paper will allow food particles and sediment to pass through the filter pan and into the pump. When sediment enters the pump, the gears can bind up causing the motor to overload, again tripping the thermal overload. Solidified shortening in the pump will also cause it to seize, with the same result.

A pump seized by debris or hard shortening can usually be freed by manually moving the gears with a screwdriver or other instrument as illustrated below. **Make sure power to the pump motor is off before trying this.**

1. Disconnect power to the filter system.
2. Remove the input plumbing from the pump.
3. Use a screwdriver to manually turn the gears.
  - Turning the pump gears backwards will release a hard particle and allow its removal.
  - Turning the pump gears forward will push softer objects and solid shortening through the pump and allow free movement of the gears.



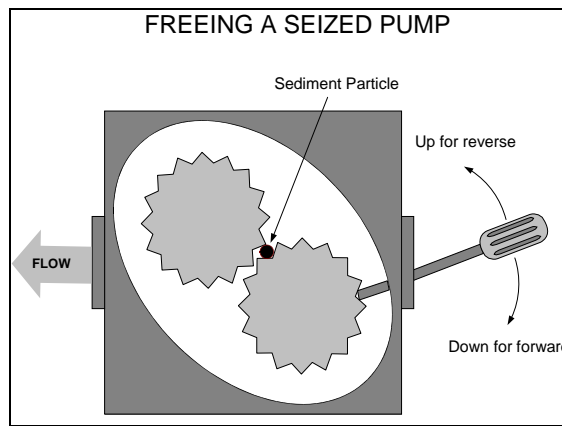

Incorrectly sized or installed paper will also allow food particles and sediment to pass through and clog the suction tube on the bottom of the filter carriage. Particles large enough to block the suction tube may indicate that the crumb tray is not being used.

Pan blockage can also occur if shortening is left in the pan and allowed to solidify. The heater strip on the suction tube is designed to prevent solidification of residual shortening left in the tube. It will not melt or prevent solidification of shortening in the pan.

Blockage removal can be accomplished by forcing the item out with an auger or drain snake. ***Never attempt to use compressed air or other pressurized gases to force out the blockage.***

Possible problems with the Power Shower include clogged openings, shortening solidified in the tubes, missing clean-out plugs, and missing or worn O-rings. Cleaning the unit and replacing missing plugs and missing or worn O-rings will correct these problems.

The electronics of the Filter Magic and FootPrint III systems are simple and straightforward. Microswitches, attached to handles for each vat and wired in parallel, provide the 24 VAC required to activate the pump relay coil when the handles are moved to the ON position. The activated pump relay coil pulls in the pump motor switch, supplying power to the pump motor.

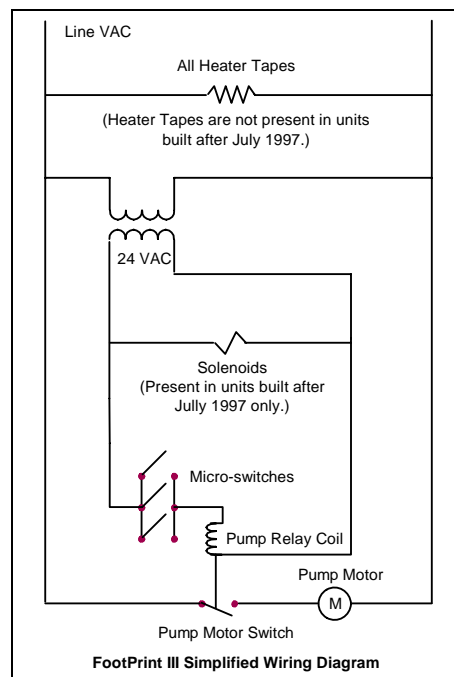
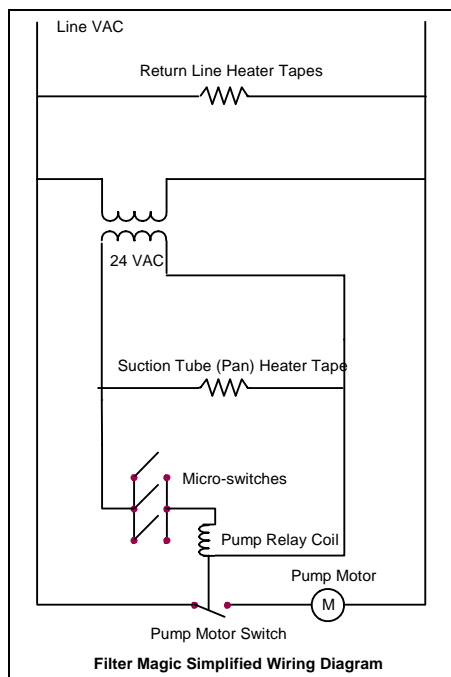

The oil return line heater tapes in the Filter Magic system are wired directly into the line VAC source and remain energized as long as the unit is plugged in. The filter pan suction tube heater tape, however, is wired into the 24 VAC circuit. The suction tube tape is activated only when the filter pan is positioned all the way to the rear of the cabinet, allowing a pair of “bullet” contactors mounted on the pan to touch a corresponding pair of contactors mounted on the cabinet frame.

For FootPrint III systems built before August 1997, all heater tapes are wired directly into the line VAC source. They remain energized as long as the unit is plugged in. In systems built in August 1997 and later, oil return line heater tapes have been eliminated. In these units, the only heater tape used is on the suction tube and pump. This tape is still wired directly into the line voltage. A pair of vacuum-breaking solenoids is wired into the 24 VAC circuit.

In units built from August 1997 onward, the oil return system allows oil to drain back to the filter pan when the filter system is turned off, eliminating the need for most heated oil return components. For a short time, one-piece, welded oil return manifolds were used. The one-piece manifolds have been replaced with Dormont stainless steel flexlines and nipples and are no longer available.

<b>PRE-AUGUST 1997 VS CURRENT DESIGN FP-III FILTRATION SYSTEM</b>	
<b>Original System</b>	<b>Redesigned System</b>
Return lines and manifolds wrapped with silicone strip heaters and aluminum tape.	No heater strips or aluminum tape on return lines.
Filter base assembly connected to unit with a black, heated return hose beneath the filter.	Non-heated Teflon hose with a swivel joint connects the filter base assembly to the unit above the filter.
Filter base assembly equipped with swivel casters.	Filter base assembly has no casters.
Operator-removable filter base assembly. (Filter base assembly stoplocks in cabinet can be rotated to remove tray.)	Filter base assembly is not removable except by a qualified service technician. (Filter base assembly stoplocks fitted with a screw and nut to prevent filter removal.)
Oil remains in return lines when filter system is turned off.	Oil gravity-drains back to the filter pan when filter system is turned off, leaving no oil or shortening in return lines.

***Power Shower Sub-System***

A solenoid vent valve is mounted on the left end of the front oil return assembly. It prevents vacuum-lock of the system as oil drains back to the filter pan when the unit is turned off. The solenoid valve is connected to the square drain sub-system by a clear 3/8” O.D. Teflon tube and threaded fittings. Stainless steel Dormont flexlines connect the manifolds to the valves. Standard 1/2” X 1/2” X 90° black metal street elbows are used to make the connections.

A 22-inch Dormont stainless steel flexline, running above the filter assembly, connects the front oil return assembly to the rear manifold.

***Filter Base Assembly and Pump Sub-System***

Castors have not been used on filter base assemblies built since August 1997. When the castors were eliminated from the filter base assembly, the assembly was redesigned to prevent it from being taken out of the cabinet without removing a set of machine screws and nuts.

A new Teflon hose with a braided stainless steel covering connects the pump to the rear manifold and replaces the heated hose running from the pump discharge under the unit to the Power Shower

plumbing. The new hose is fitted with a 90° swivel at the manifold end and a straight swivel at the pump end to prevent kinking.

The pump plumbing features a solenoid valve at the pump discharge, a ¼” I.D. Dormont stainless steel flexline that connects the solenoid valve to the pump inlet fittings, and miscellaneous standard black metal fittings for connections. This design allows oil to bypass the pump as it drains from the oil return lines back into the filter pan when the system is turned off. Bypassing the pump expedites draining of the lines. The pump solenoid leads are connected to Pins 7 and 9 of the upper 9-pin plug assembly of the filter box.

### ***Filter Wiring Box***

The original-design 5-lead cable connecting the filter assembly to the filter wiring box has been replaced with a new, universal 7-lead cable to accommodate the solenoid mounted on the front manifold. The two new leads have a separate connector for attachment to the solenoid. When a filter cable is ordered for either filtration system configuration (original or redesigned), the new 7-wire cable will be sent. The two extra wires and connector will not interfere with the original filtration system or its operation.

### ***Verifying Solenoid Operation***

Proper operation of the 24VAC manifold and pump solenoids can be verified by removing the pump motor lead from terminal 4 of the pump motor relay in the filter wiring box and then activating the oil return lever. Proper solenoid operation will be evidenced by an audible “click” or vibration of both the pump solenoid and the manifold solenoid.

## **1.7.6 Leakage**

Leakage of the frypot is usually due to improperly sealed high limit thermostats, temperature probes, and drain fittings. When installed or replaced, each of these components must be sealed with Loctite® PST56765 sealant or equivalent to prevent leakage and torqued to 180 inch-pounds. In very rare cases, a leak may develop along one of the welded edges of the frypot. When this occurs, the frypot must be replaced.

If the sides and/or ends of the frypot are coated with oil, the most likely cause is spillage over the top of the frypot rather than leakage.

The clamps, which hold the drain tube sections together, may loosen over time as the tubes expand and contract with heating and cooling during use. If the section of drain tube connected to the drain valve is removed for whatever reason, make sure that its grommet is in good condition and properly fitted around the nipple of the drain when it is reinstalled. Also, ensure that the drain tube runs downward from the drain along its whole length and has no low points, where oil may accumulate.

## **1.7.7 Basket Lift Malfunctions**

H50 Series fryers may optionally be equipped with automatic basket lifts to ensure uniform cooking times. Basket lifts will always come in pairs, although each operates independently of the other. Depending upon the specific model, date of manufacture, and customer specifications, an H50 fryer may be equipped with a bell crank style basket lift, or a “modular” basket lift.

A **modular basket lift** (illustrated below) consists of a toothed rod to which the basket lift arm is attached, a reversible-drive gear motor, and a pair of roller-activated microswitches. The gear motor engages the teeth in the rod, moving it up or down depending upon the direction of rotation of the motor. Microswitches at the upper and lower limits of movement stop the motor when the basket is in the full up or full down position.

Timing circuitry in the controller initiates and stops basket lift operation depending upon the variables programmed by the operator. When the product button is pressed, the timing circuitry activates a coil in the basket lift relay to supply power to the lower microswitch. The microswitches stop the motor at the lift's upper and lower travel limits and reverse the direction of current flow, thus reversing the motor direction.

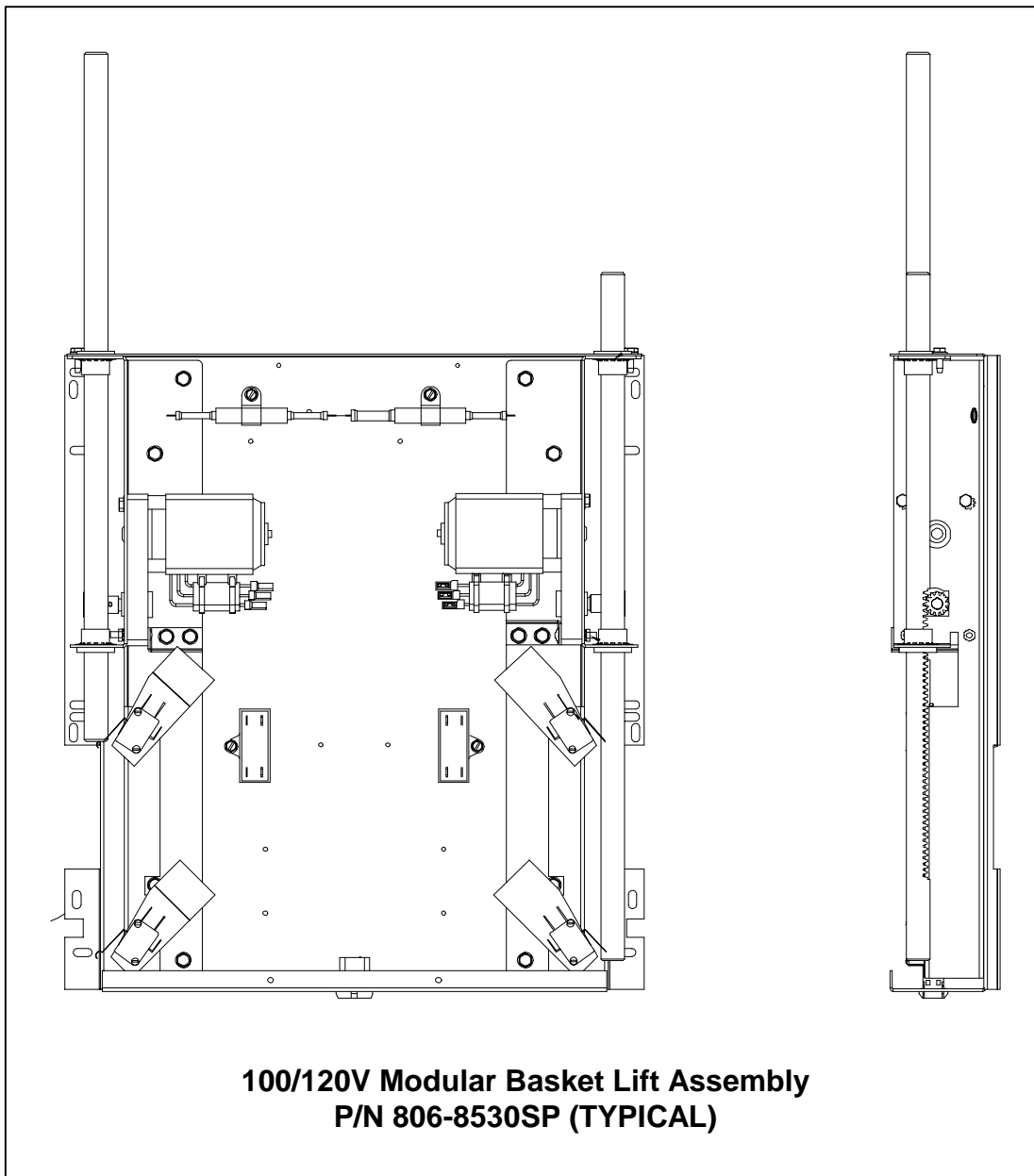

A **bell crank style basket lift** consists of a cam and bell crank that are connected to the basket lift arm by a flat metal link. The cam is attached to a drive motor. The motor rotates the cam, thus raising or lowering the lift arm linked to the bell crank. A roller-activated microswitch is used to limit travel. When the roller in the microswitch is in contact with the cam, the motor is energized. As the cam rotates, the microswitch roller eventually loses contact with the cam and the circuit is broken, de-energizing the motor.

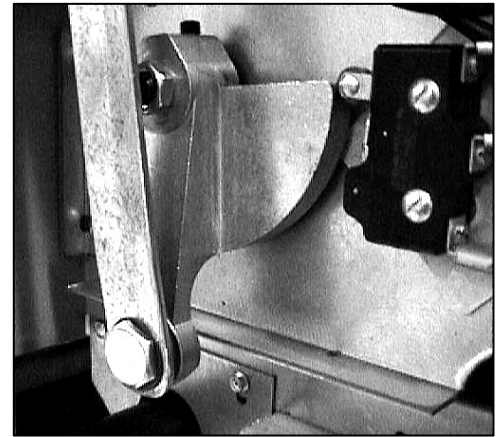

**Bell crank and cam with basket lift link shown in down position. Note microswitch in upper right corner.**

Timing circuitry in the controller initiates and stops basket lift operation depending upon the variables programmed by the operator. When the product button is pressed, the timing circuitry activates a coil in the basket lift relay to supply power to the motor. The microswitch stops the motor at the lift's lower travel limit and the switch contacts are reversed. At the end of the programmed cooking time, the timing circuit activates the coil once more and the lift rises until the microswitch again loses contact with the cam, opening the circuit and stopping the motor.

Problems with either basket lift design can be grouped into three categories:

- Binding/jamming problems
- Motor and gear problems
- Electronics problems

### **BINDING/JAMMING PROBLEMS**

Noisy, jerky or erratic movement of the lifts is usually due to lack of lubrication of the rods and their bushings. Apply a light coat of Lubriplate<sup>®</sup> or similar lightweight white grease to the rod and bushings to correct the problem.

With the modular basket lift, another possible cause of binding is improper positioning of the motor, which prevents the gear from correctly engaging the teeth in the rod. To correct the problem, loosen the screws that hold the motor in place and move it forward or backward until the rod has just enough slack to be rotated slightly.

### **MOTOR AND GEAR PROBLEMS**

With the modular basket lift, the most likely problem to be encountered in this category is erratic motion of the lift due to a worn drive gear. Failure to keep the lift rod and bushings properly lubricated will cause unnecessary wear of the gear. The problem is corrected by replacing the worn gear.

If the lift cycles correctly but fails to remain in the up position (i.e., goes up, but then slowly settles back down into the frypot), the problem is a failed motor brake. A failed motor brake cannot be repaired and requires replacement of the motor itself.

If power is reaching the motor but the motor fails to run, the motor is burned out and must be replaced.

## **ELECTRONICS PROBLEMS**

Within this category are problems associated with the relays, microswitches, capacitors, resistors, interface board, wiring, and controls. The most common problem in this category is a lift that continuously travels up and down. This is usually caused by a microswitch that is out of adjustment.

Troubleshooting the electronics of either type basket lift is simply a process of verifying current flow through the individual components up to and including the motor. Using a multimeter set to the 250 VAC range, check the connections on both sides of the component for the presence of the applied line voltage. The accompanying simplified wiring diagrams identify the components and wiring connection points.

### **1.7.8 Interpretation of Digital Controller Lights**

#### **Power light on, heat light cycling, trouble light off, and melt light on:**

- If fryer oil temperature is below 180°F (82°C), the lights indicate the unit is operating normally.
- If the oil temperature is above 180°F (82°C) and the heat light continues to cycle as if in the melt cycle, this may indicate a defective probe circuit or low incoming 12VAC to the controller.

#### **Power light on, heat light on, trouble light off, and melt light off:**

- If the fryer oil temperature is above 180°F (82°C) and below the setpoint temperature, the lights indicate the unit is operating properly.
- If the oil temperature is above the temperature set on the control knob and the heat light remains lit, this may indicate a defective probe circuit.

#### **Power light on, heat light off, trouble light on, and melt light off:**

- If the fryer oil temperature is below 410°F (210°C), the lights indicate one of the following:
  - a. The probe circuit is defective, or
  - b. There is a connection problem on pins 2 or 10 on the 15-pin wiring harness.
- If the fryer oil temperature is above 410°F (210°C), the lights indicate a run-away heating circuit.

## **1.8 Troubleshooting Guide**

The troubleshooting guide that follows is intended to assist service technicians in quickly isolating the probable causes of equipment malfunctions. An additional set of operator troubleshooting guides is contained in Chapter 6 of the H50 Series Installation and Operation Manual (P/N 819-5000). It is suggested that service technicians thoroughly familiarize themselves with both sets.

PROBLEM	PROBABLE CAUSES	CORRECTIVE ACTION
<p style="text-align: center;"><b>24V circuit is suspect.</b></p> <p><b>NOTE:</b> All voltage measurements must be made within 4 seconds of the controller calling for heat. If the burners do not fire within 4 seconds, the ignition modules will lock out and the controller must be turned off and then back on to reset them.</p>	<p>A. Failed 24V transformer.</p> <p><i>Check:</i> LED 3 (24V) is not lit continuously.</p>	<p>A. If the wiring and connections between the 24V transformer and the interface board are intact, replace the transformer.</p>
	<p>B. Failed interface board.</p> <p><i>Check 1:</i> LED 3 (24V) is lit continuously, but 24 VAC is not present on the right PWR terminal (LED 4) (and/or the left PWR terminal (LED 2), if dual-vat).</p> <p><i>Check 2:</i> 24VAC is present on V1s (or V1D and V2D, if dual vat).</p>	<p>B. Replace the interface board.</p>
	<p>C. Open or failed drain safety switch.</p> <p><i>Check:</i> If 24VAC is present on the gas valve main coil (PV terminal) (on both PV terminals, if dual-vat), check the connections and the continuity of the drain safety switch.</p>	<p>C. Adjust or replace the drain safety switch as appropriate.</p>
	<p>D. Failed high limit.</p> <p><i>Check:</i> If 24VAC is present on the gas valve main coil (PV terminal) (on both PV terminals, if dual-vat), check the continuity of the high limit.</p>	<p>D. If the high limit is open, replace.</p>
	<p>E. Failed ignition module.</p> <p><i>Check:</i> 24VAC is not present on V1S (or V1D and V2D, if dual vat).</p>	<p>E. If the fuse in the ignition module is not blown, replace the ignition module.</p>

Refer also to the diagrams of the 24 Volt Circuit on the following pages.

**24 VOLT CIRCUIT**  
 With Interface Board 806-3398 or 106-0386 and  
 Two 807-1006 (FV/DV), 807-2971 (FV/DV), or 807-3365 (DV) Ignition Modules

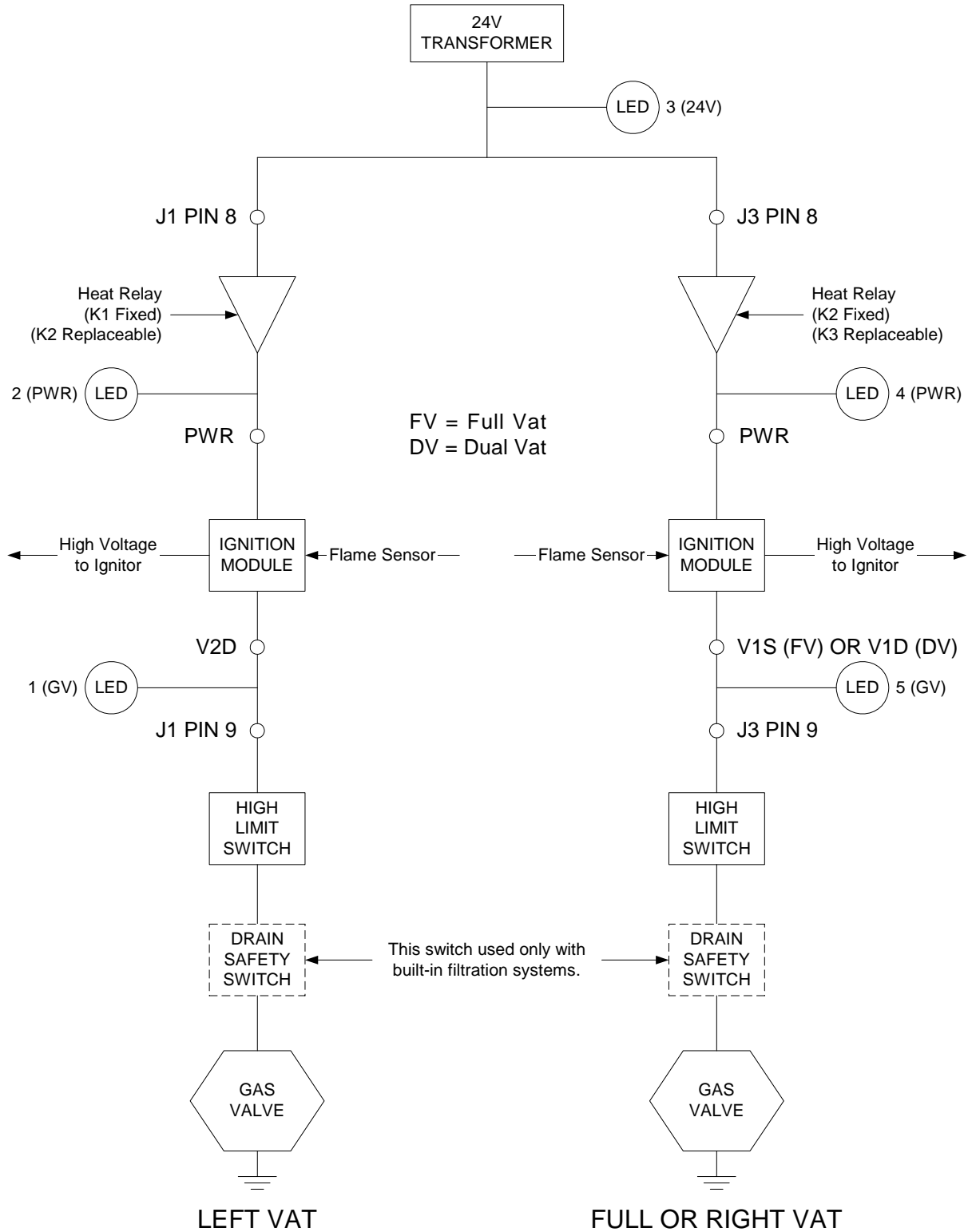



## 24 VOLT CIRCUIT

With Interface Board 806-3398 or 106-0386 and  
One 807-3366 (FV) Ignition Module

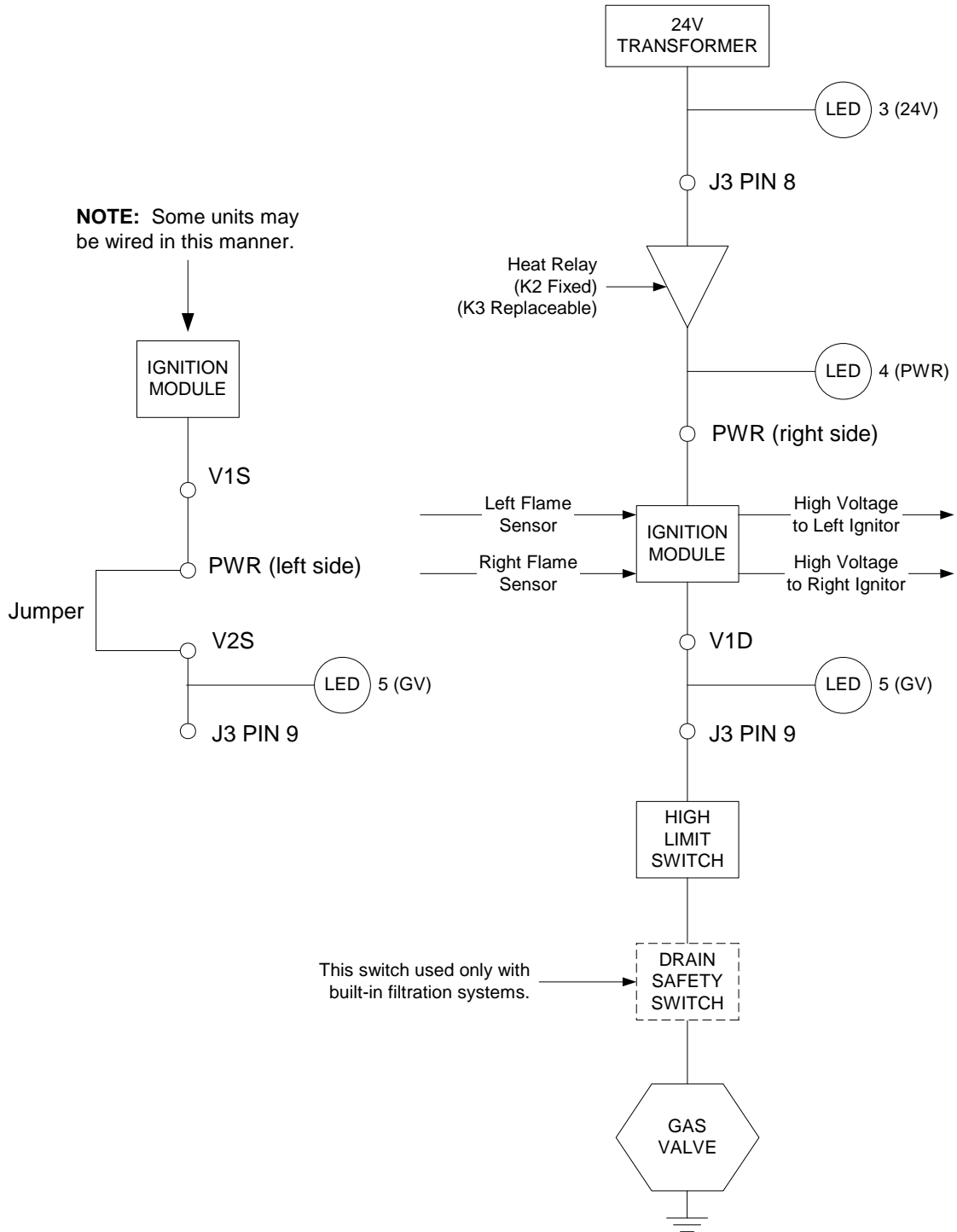

PROBLEM	PROBABLE CAUSES	CORRECTIVE ACTION
<p><b>Gas supply or gas valve is suspect.</b></p>	<p>A. Gas valve in non-CE is in OFF position.</p>	<p>A. Place gas valve in ON position.</p>
	<p>B. Gas valve in non-CE is in OFF position.</p>	<p>B. Place gas valve in ON position.</p>
	<p>C. Improper incoming gas pressure.</p> <p><i>Check:</i> Incoming gas pressure is in accordance with the appropriate table on Page 1-23 of this manual.</p>	<p>C. Bring incoming gas pressure into accordance with the appropriate table on Page 1-23 of this manual.</p>
	<p>D. Improper burner manifold gas pressure.</p> <p><i>Check:</i> Burner manifold pressure is in accordance with the appropriate table on Page 1-7 of this manual.</p>	<p>D. Adjust the gas valve (see procedure 1.4 of this manual) to bring the burner manifold pressure into accordance with the appropriate table on Page 1-7 of this manual. If the manifold pressure cannot be properly adjusted, replace the gas valve.</p>
<p><b>Temperature probe is suspect.</b></p>	<p>A. Damaged probe.</p> <p><i>Check:</i> While it is still in the frypot, inspect the probe for damage.</p>	<p>A. Replace the probe if the body is bent, dented, or cracked, or if its wiring is burned, broken, frayed, or kinked.</p>
	<p>B. Failed probe.</p> <p><i>Check 1:</i> Determine the temperature of the oil in the frypot using a thermometer or pyrometer placed at the tip of the probe, then check the for a resistance through J3 pins 2 and 6 (J1 pins 2 and 6 for the left side of a dual vat) approximately equal to that given in the Probe Resistance Chart for the corresponding temperature.</p> <p><i>Check 2:</i> Check for at least 5 megaohms of resistance through each of the previously tested pins to ground.</p>	<p>B. If probe does not test OK for both checks, replace the probe.</p>

# Probe Resistance Chart

*For use with H50 Series fryers manufactured with Minco Thermistor probes only.*

F	OHMS	C	F	OHMS	C	F	OHMS	C	F	OHMS	C	F	OHMS	C
60	1059	16	130	1204	54	200	1350	93	270	1493	132	340	1634	171
65	1070	18	135	1216	57	205	1361	96	275	1503	135	345	1644	174
70	1080	21	140	1226	60	210	1371	99	280	1514	138	350	1654	177
75	1091	24	145	1237	63	215	1381	102	285	1524	141	355	1664	179
80	1101	27	150	1247	66	220	1391	104	290	1534	143	360	1674	182
85	1112	29	155	1258	68	225	1402	107	295	1544	146	365	1684	185
90	1122	32	160	1268	71	230	1412	110	300	1554	149	370	1694	188
95	1133	35	165	1278	74	235	1422	113	305	1564	152	375	1704	191
100	1143	38	170	1289	77	240	1432	116	310	1574	154	380	1714	193
105	1154	41	175	1299	79	245	1442	118	315	1584	157	385	1724	196
110	1164	43	180	1309	82	250	1453	121	320	1594	160	390	1734	199
115	1174	46	185	1320	85	255	1463	124	325	1604	163	395	1744	202
120	1185	49	190	1330	88	260	1473	127	330	1614	166	400	1754	204
125	1195	52	195	1340	91	265	1483	129	335	1624	168	405	1764	207



# H50 SERIES— FULL-VAT— BEFORE JUNE 1996 & AFTER JULY 1999 (ONE DUAL FUNCTION HEAT/BLOWER RELAY (K3) AND TWO IGNITION MODULES)

**DRAIN SAFETY SWITCH  
ONLY ON MODELS WITH  
BUILT-IN FILTRATION**

**AIR SWITCH  
ONLY ON CE AND SOME  
EXPORT UNITS**

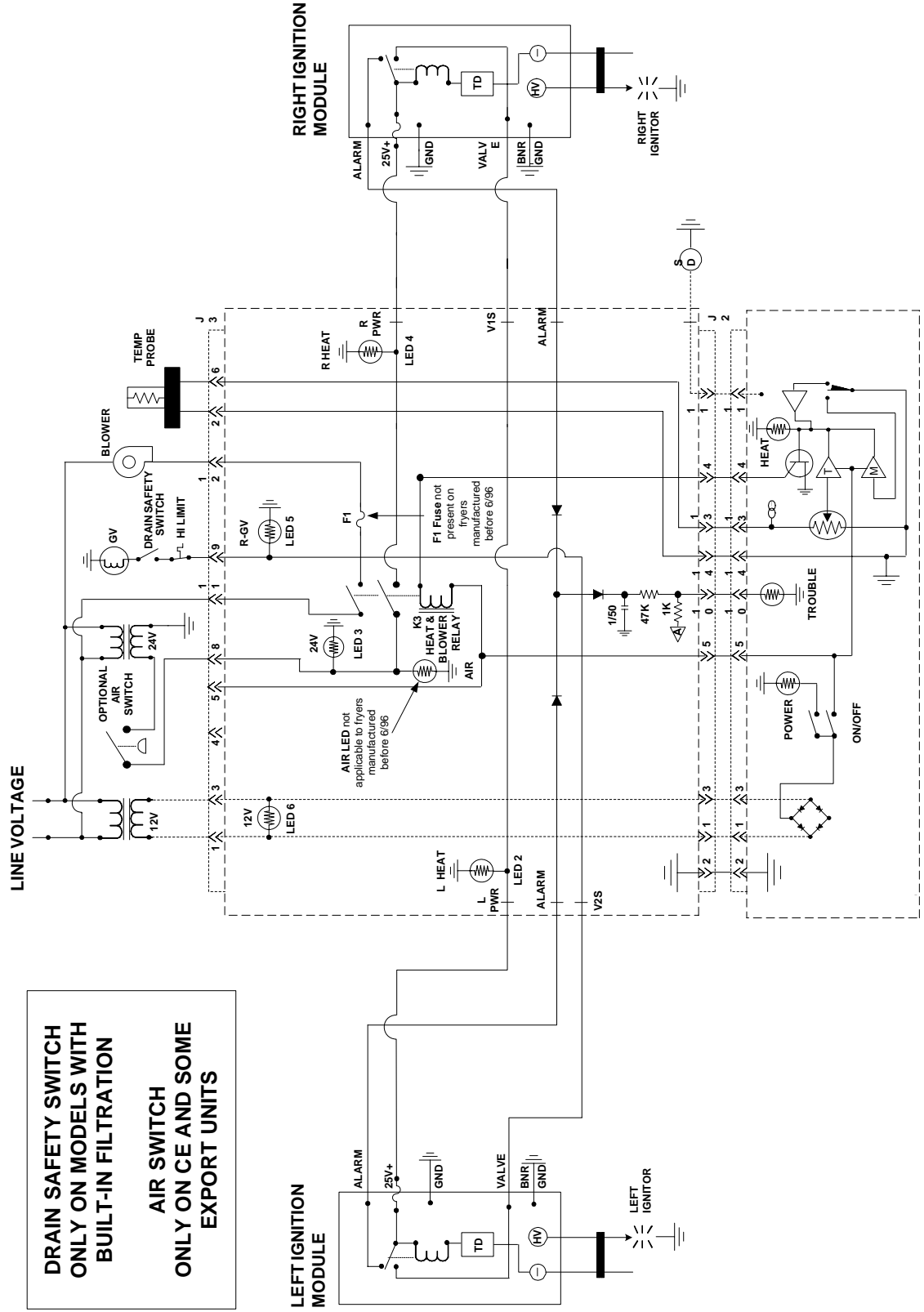

# H50 SERIES— FULL-VAT WITH ONE DUAL-SPARK IGNITION MODULE (ONE DUAL FUNCTION HEAT/BLOWER RELAY (K3))

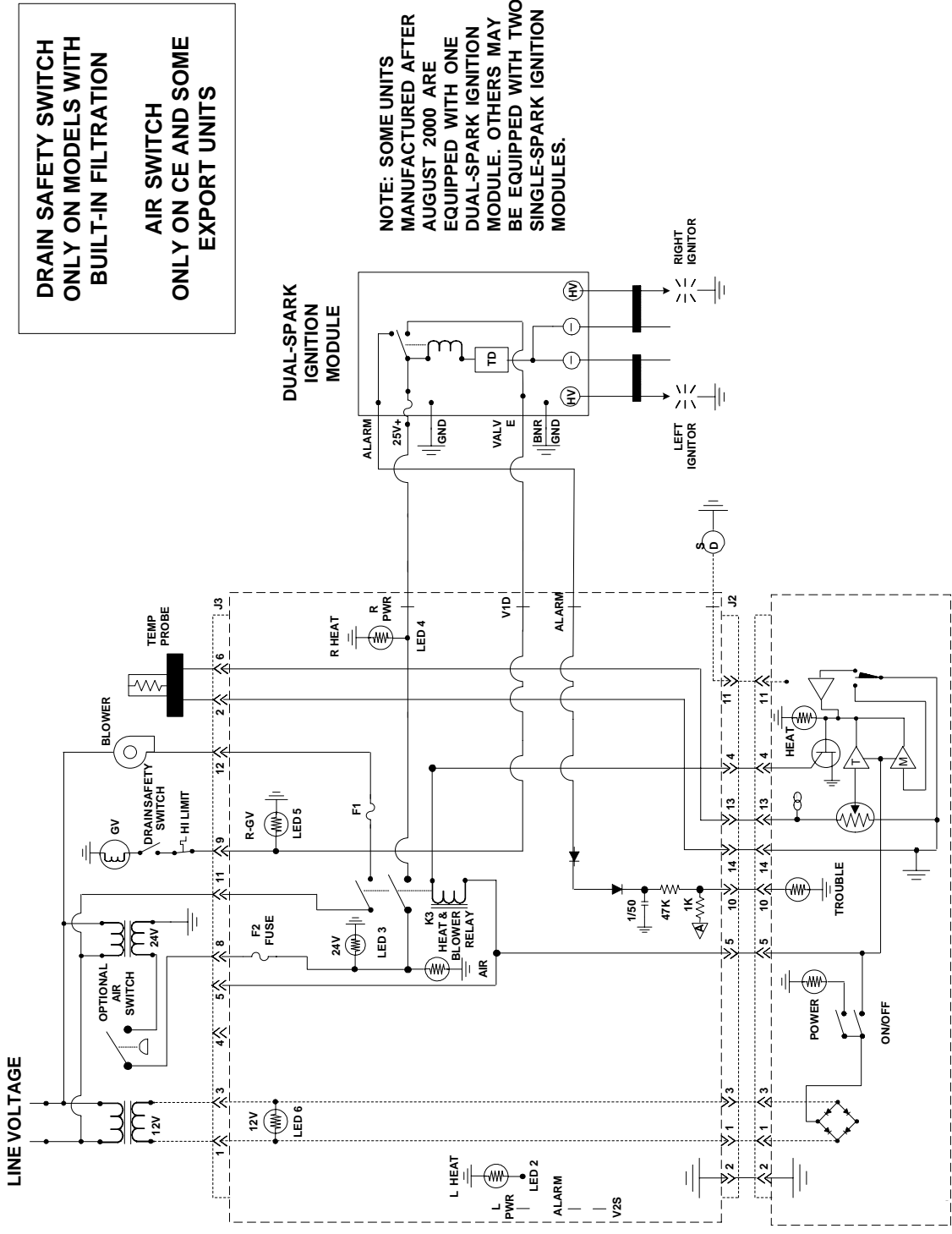

**DRAIN SAFETY SWITCH ONLY ON MODELS WITH BUILT-IN FILTRATION**

**AIR SWITCH ONLY ON CE AND SOME EXPORT UNITS**



# H50 SERIES — DUAL-VAT — BEFORE JUNE 1996 & AFTER JULY 1999 (TWO DUAL-FUNCTION HEAT/BLOWER RELAYS (K1 & K2))

**DRAIN SAFETY SWITCH  
ONLY ON MODELS WITH  
BUILT-IN FILTRATION**

**AIR SWITCH  
ONLY ON CE AND SOME  
EXPORT UNITS**

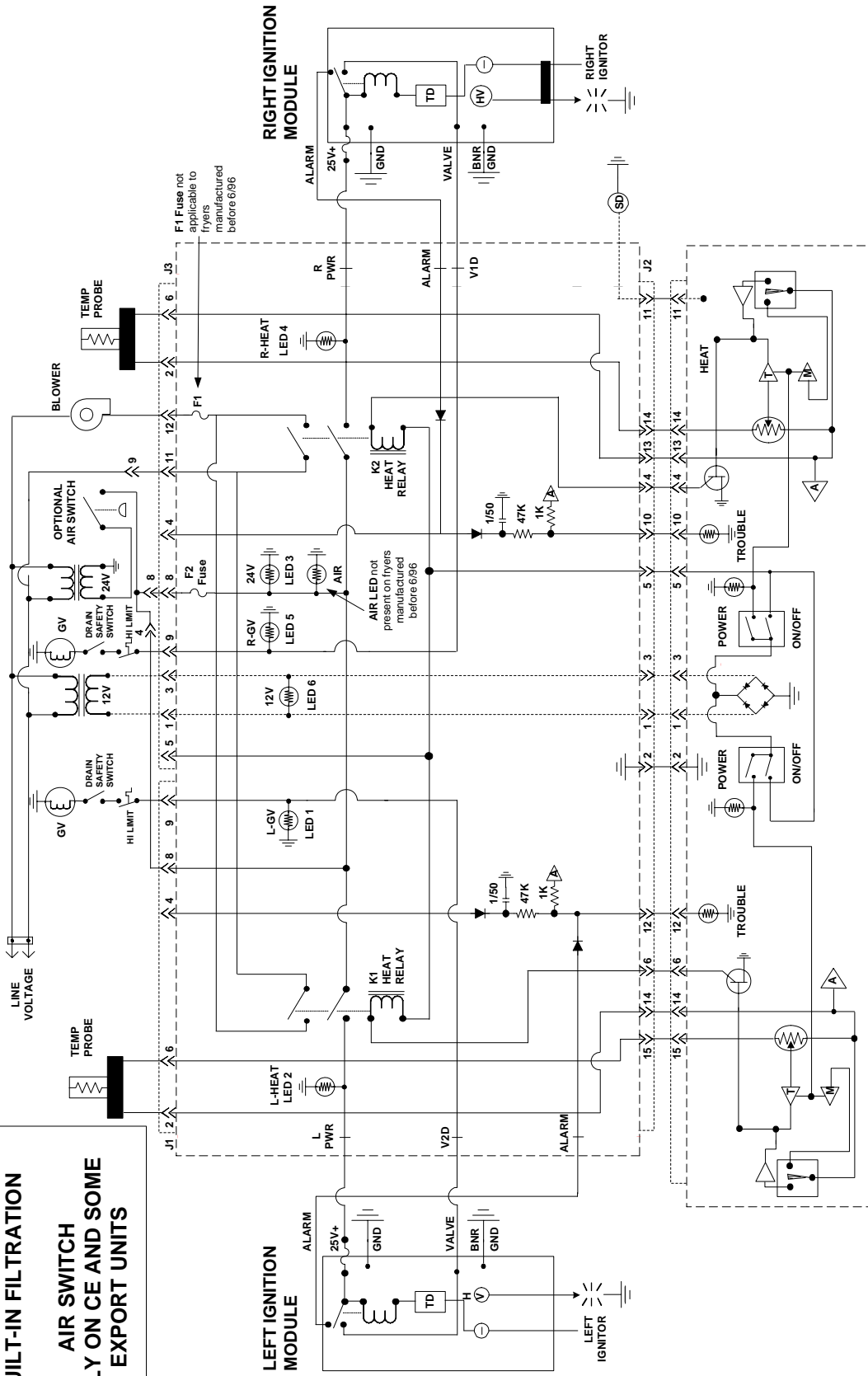



# 1.10 Principal Wiring Connections

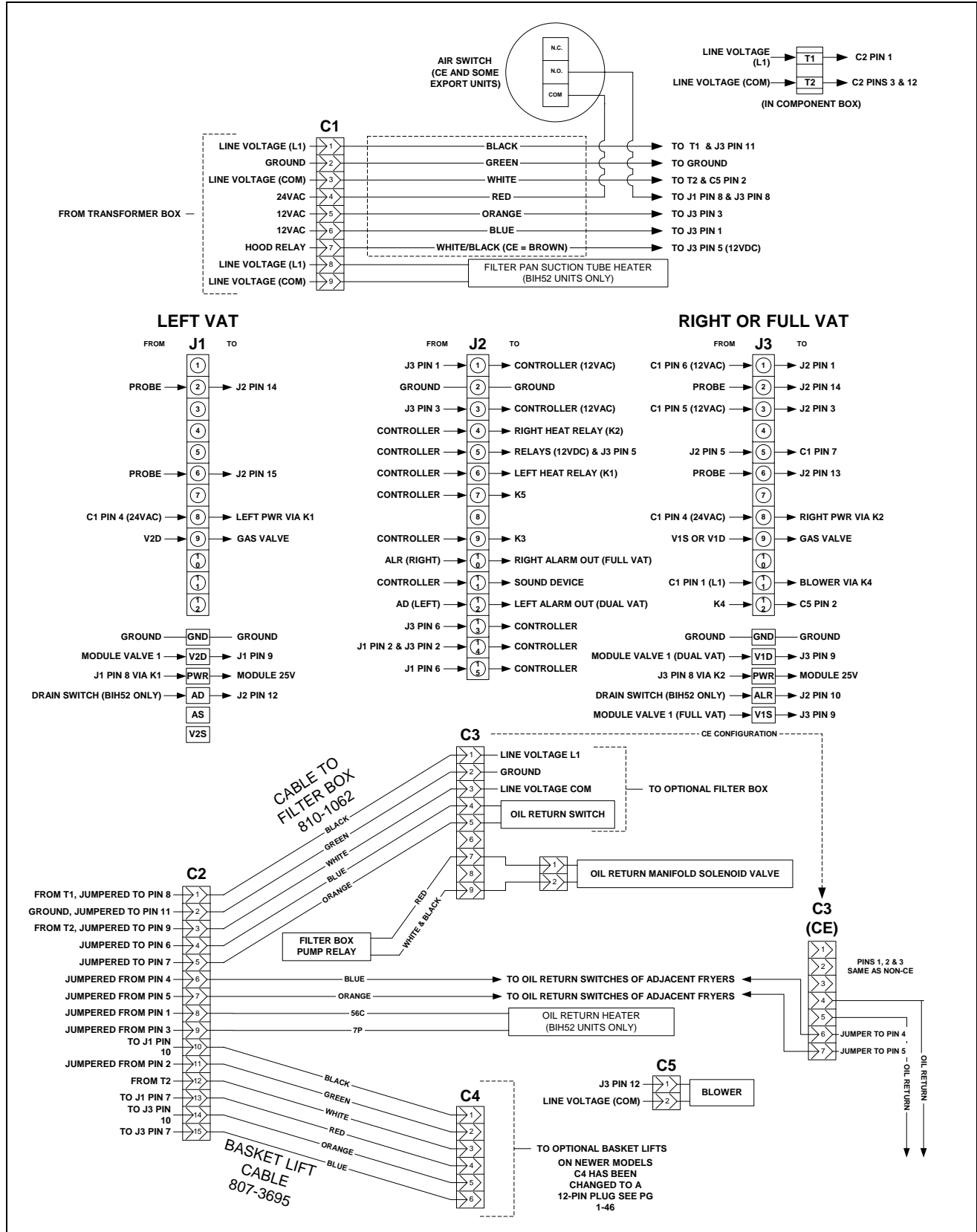

# 1.11 WIRING DIAGRAMS - MAIN

## FPH150 ONLY (NON-CE)

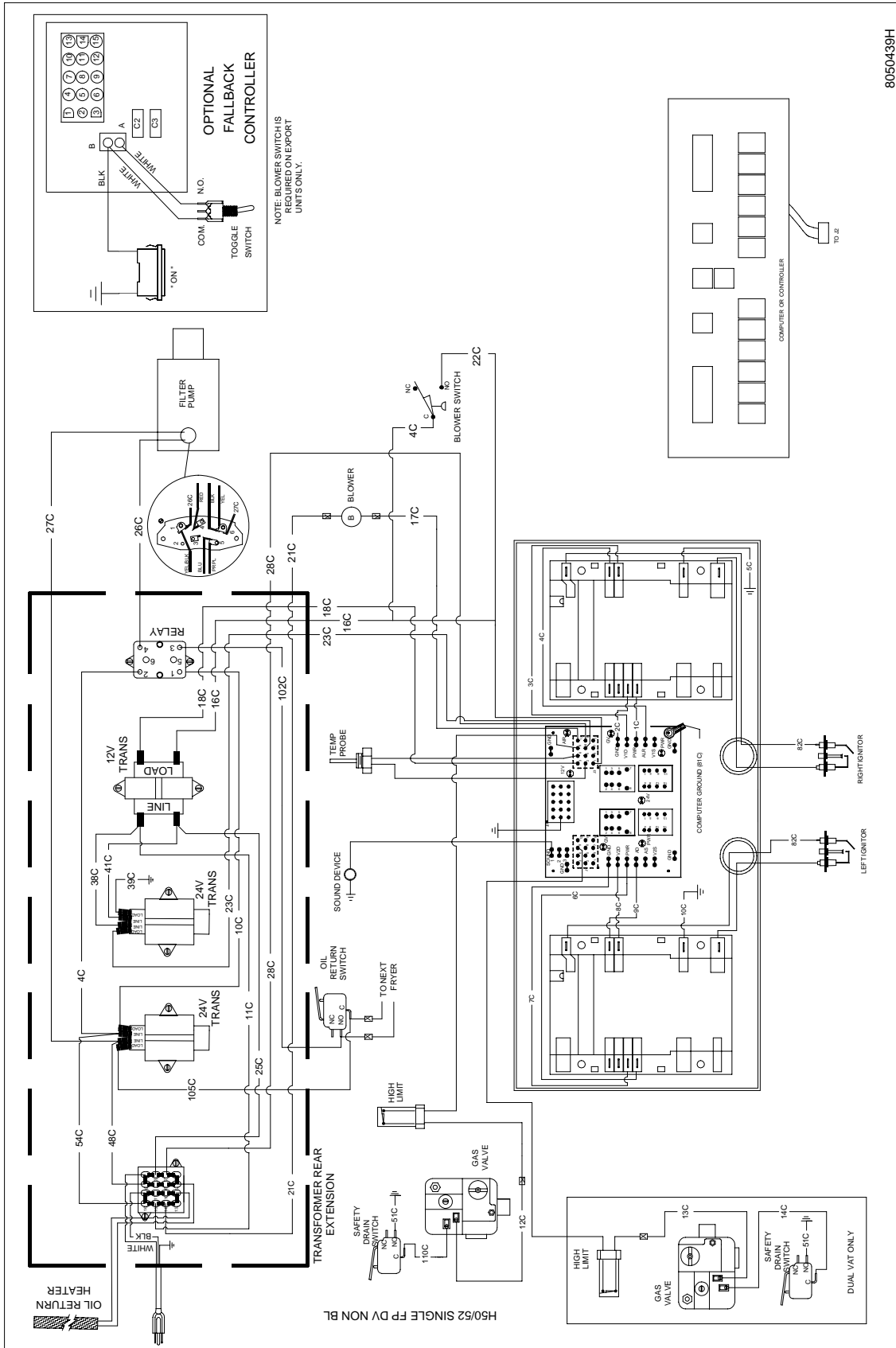

8050439H

FPH150 ONLY (CE)

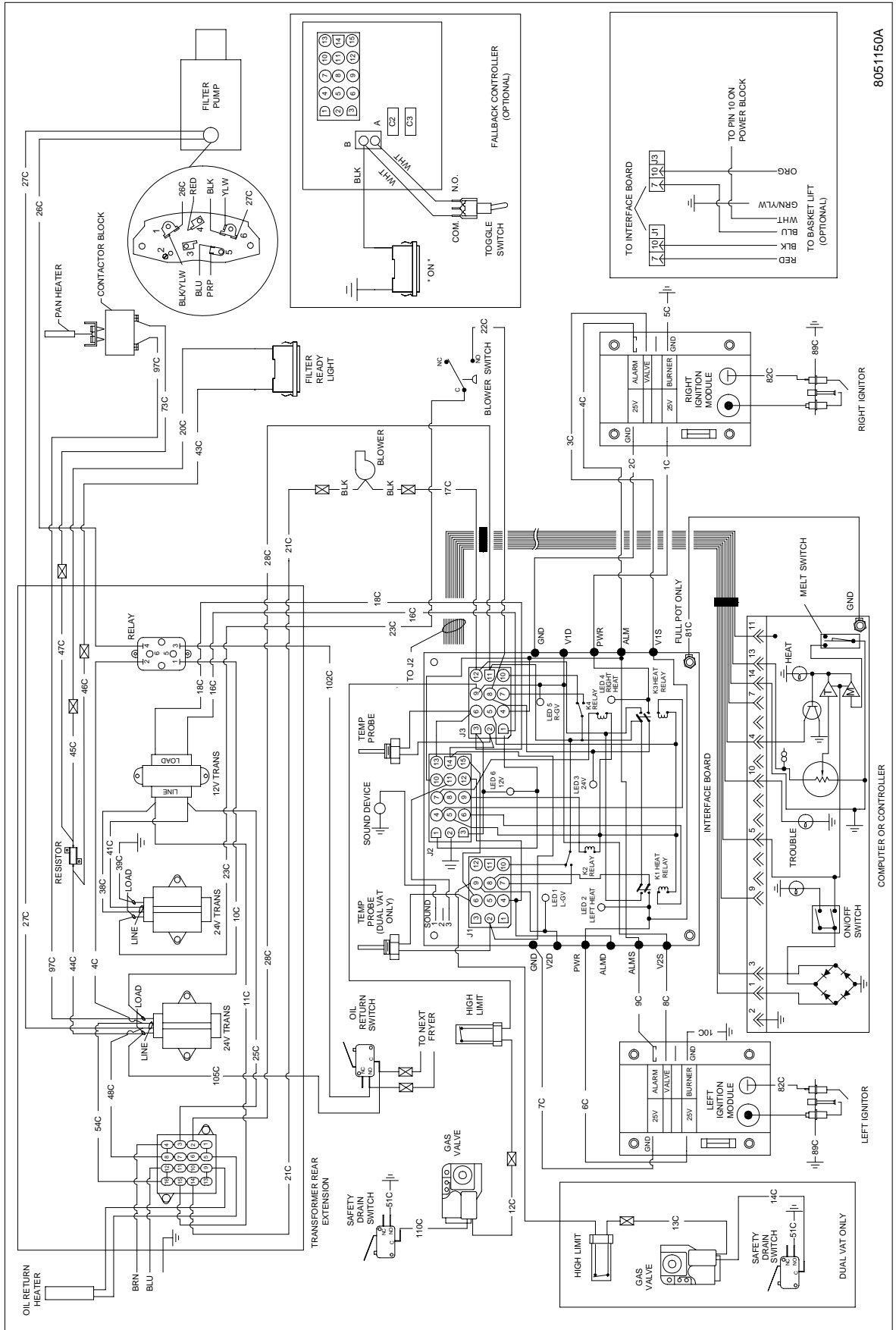

8051150A

# H50 SERIES (NON-CE) OTHER THAN FPH150 AND MANUFACTURED GAS UNITS (Old Single Spark Ignition Module)

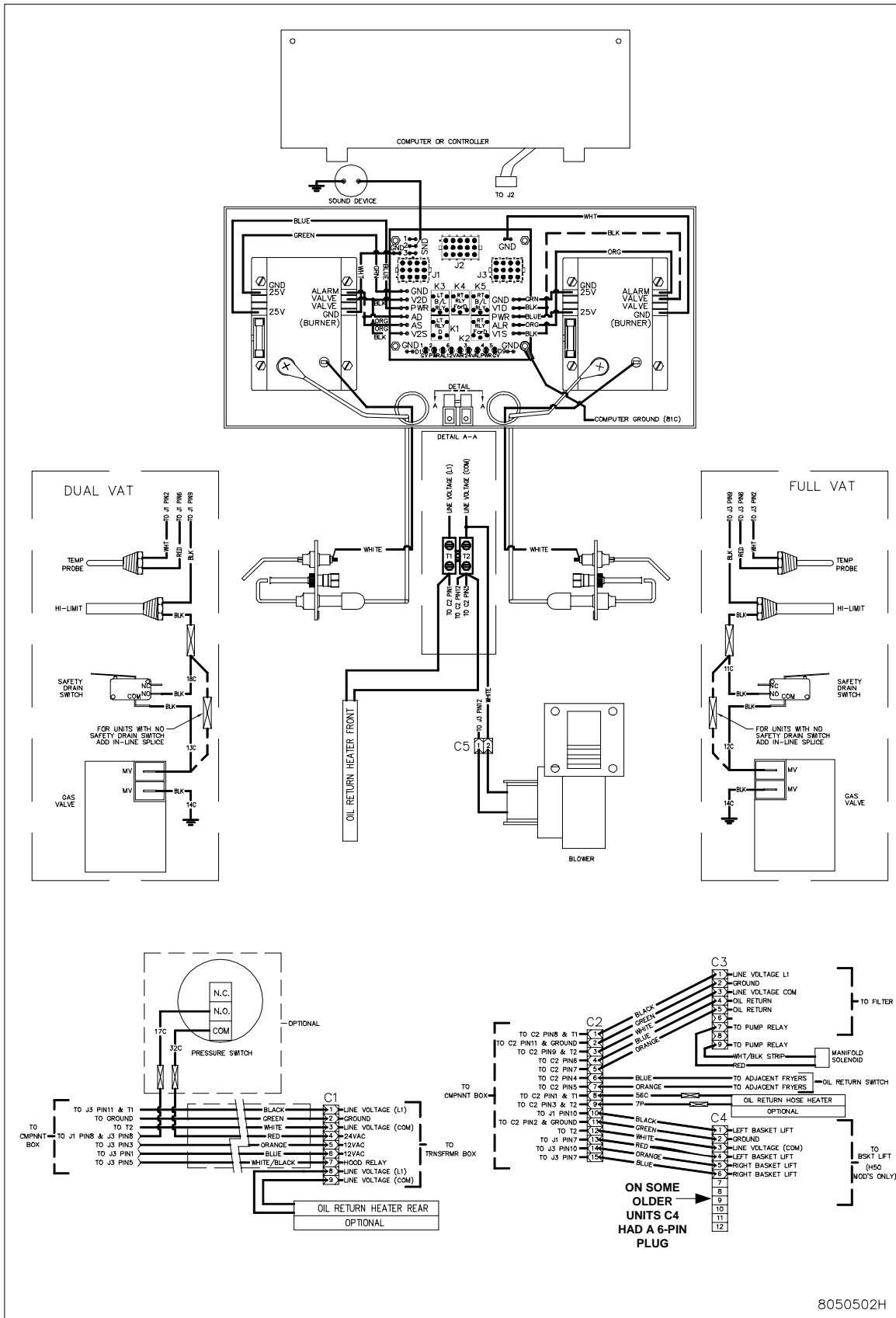

8050502H

# H50 SERIES (NON-CE) OTHER THAN FPH150 AND MANUFACTURED GAS UNITS (Newer Dual-Spark Ignition Module)

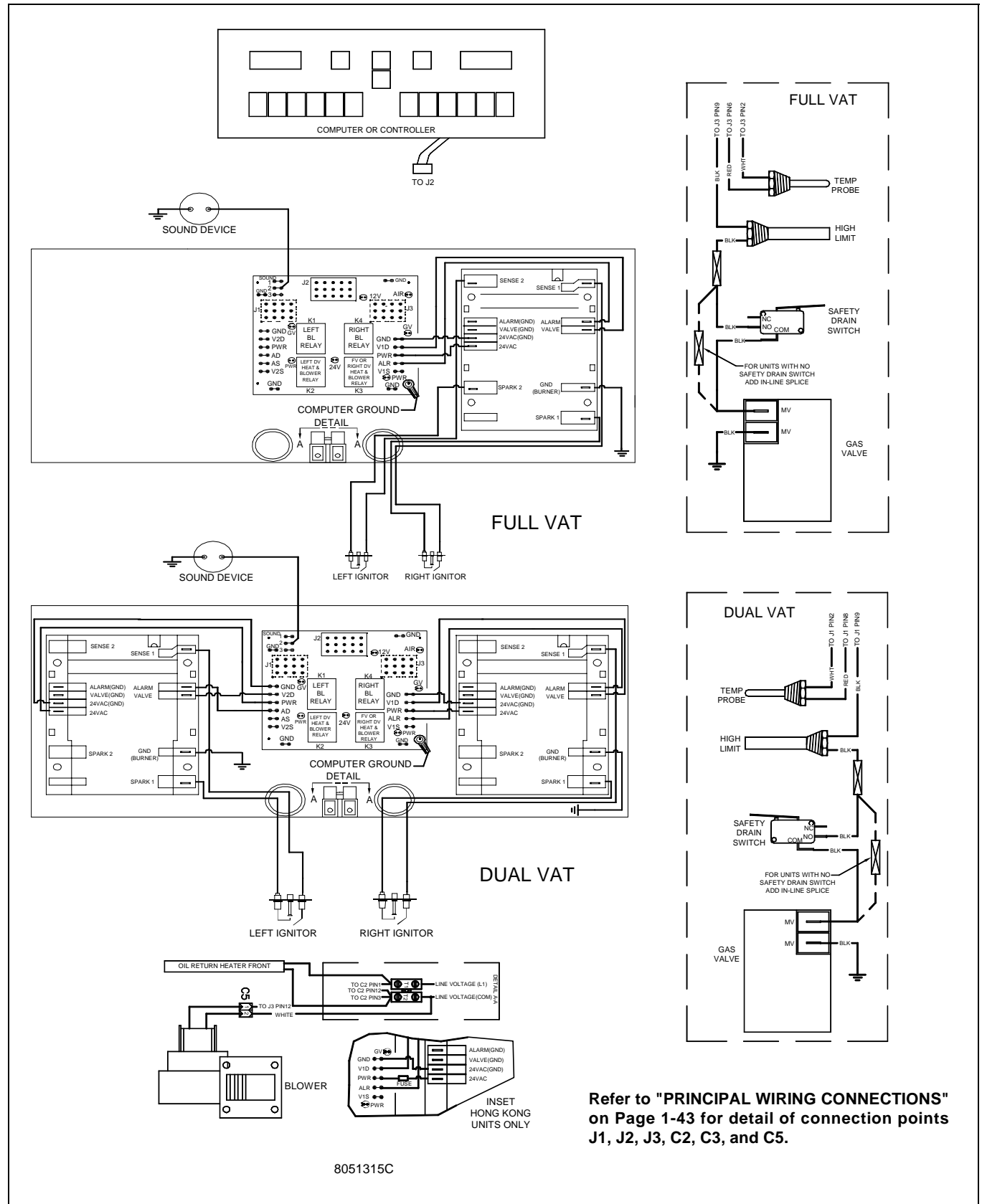

Refer to "PRINCIPAL WIRING CONNECTIONS" on Page 1-43 for detail of connection points J1, J2, J3, C2, C3, and C5.

# H50 SERIES (CE) OTHER THAN FPH150 AND MANUFACTURED GAS UNITS

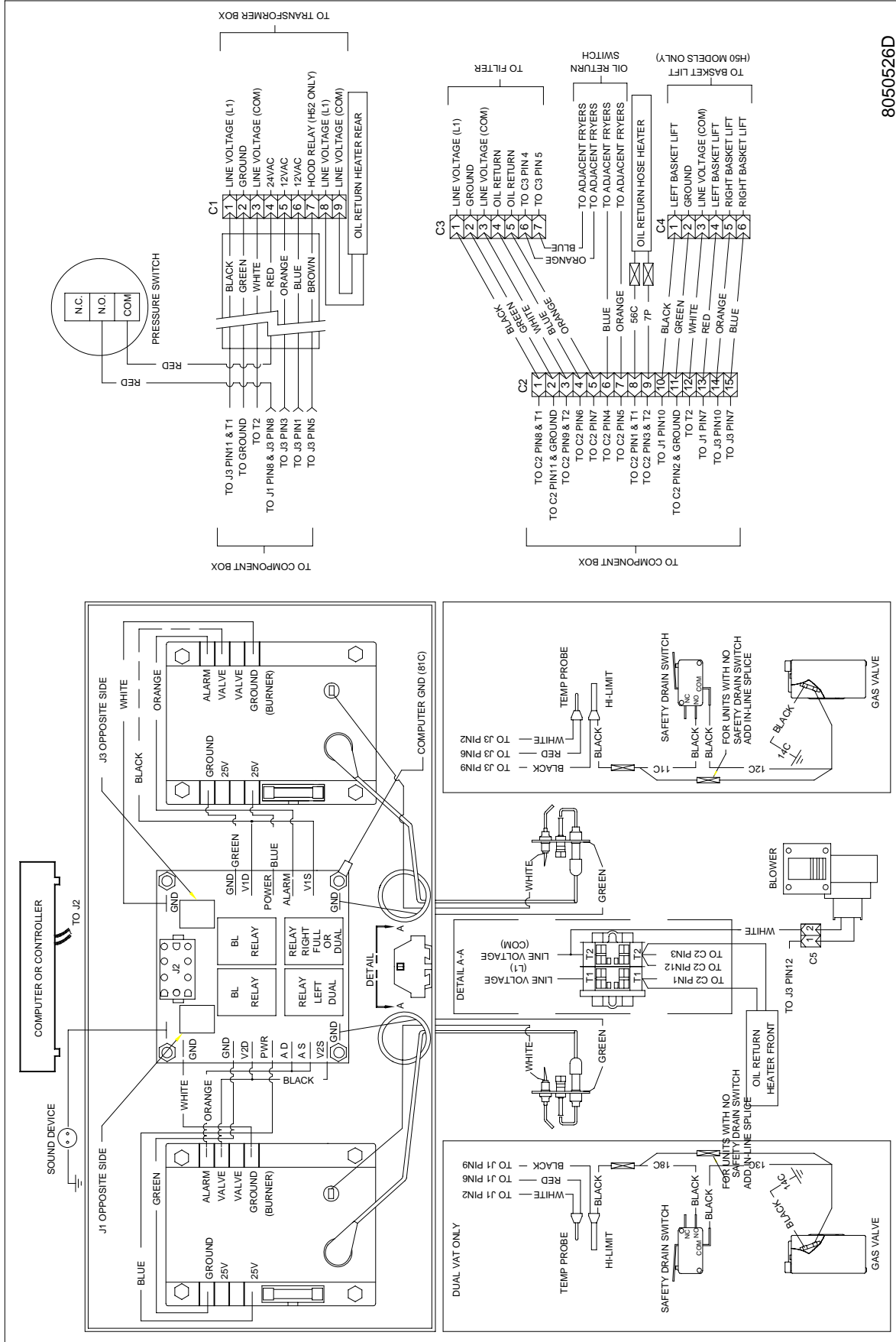

8050526D



# 1.12 WIRING DIAGRAMS – TRANSFORMER BOXES

## Non-CE Transformer Boxes

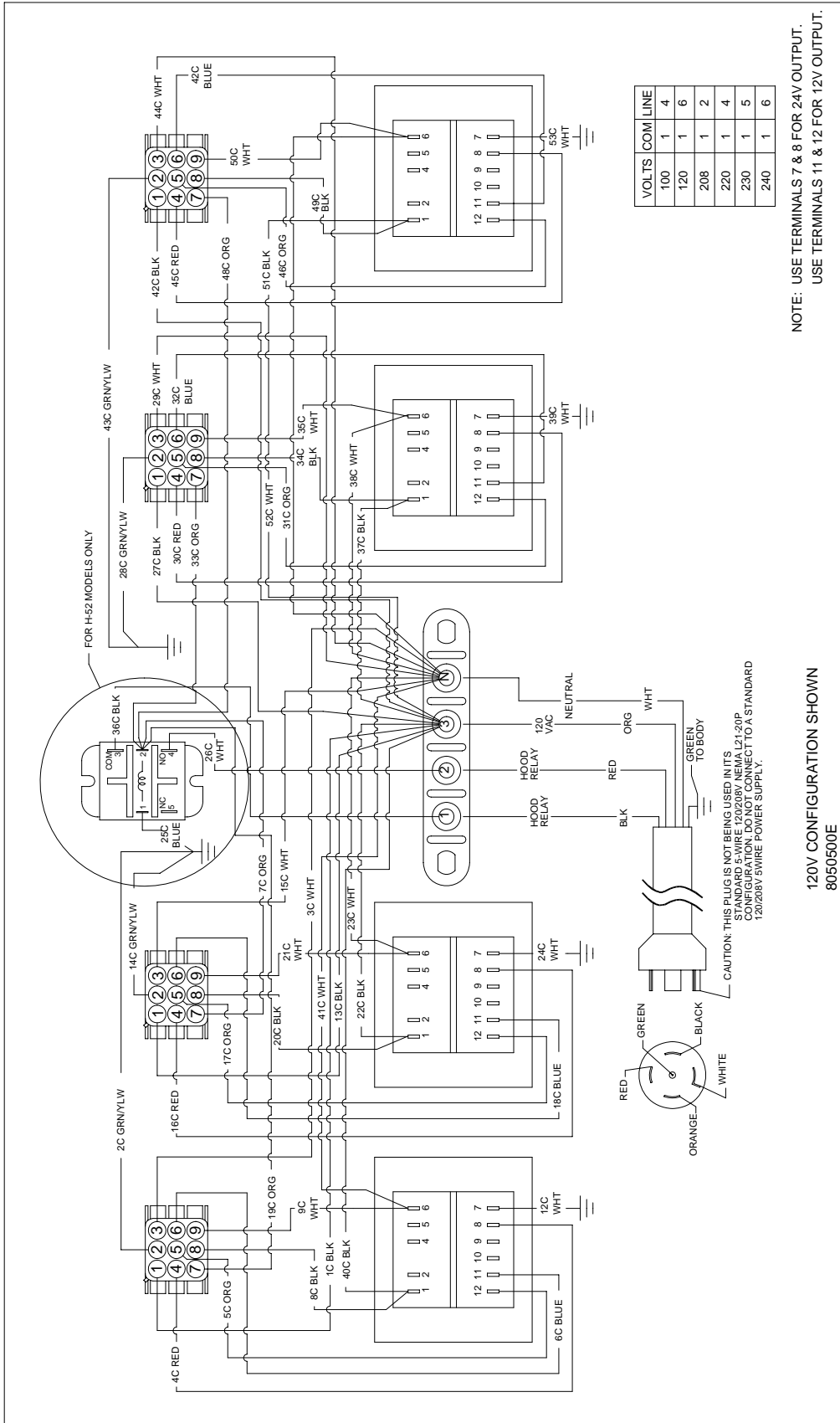



# CE Transformer Boxes

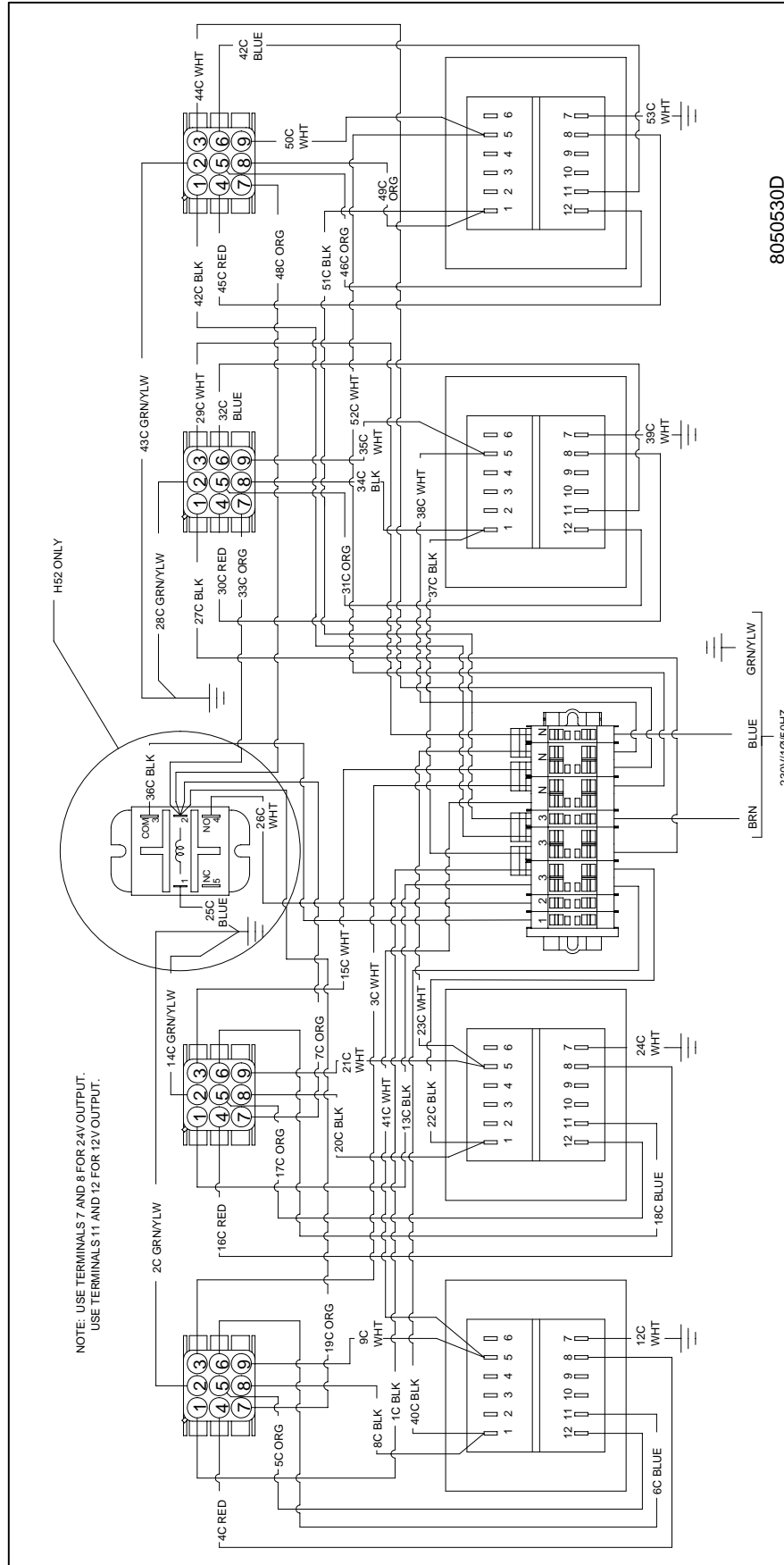

### 1.13 WIRING DIAGRAMS – BASKET LIFTS

Modular Basket Lift – 100/120V (NOTE: There is no CE version of this option.)

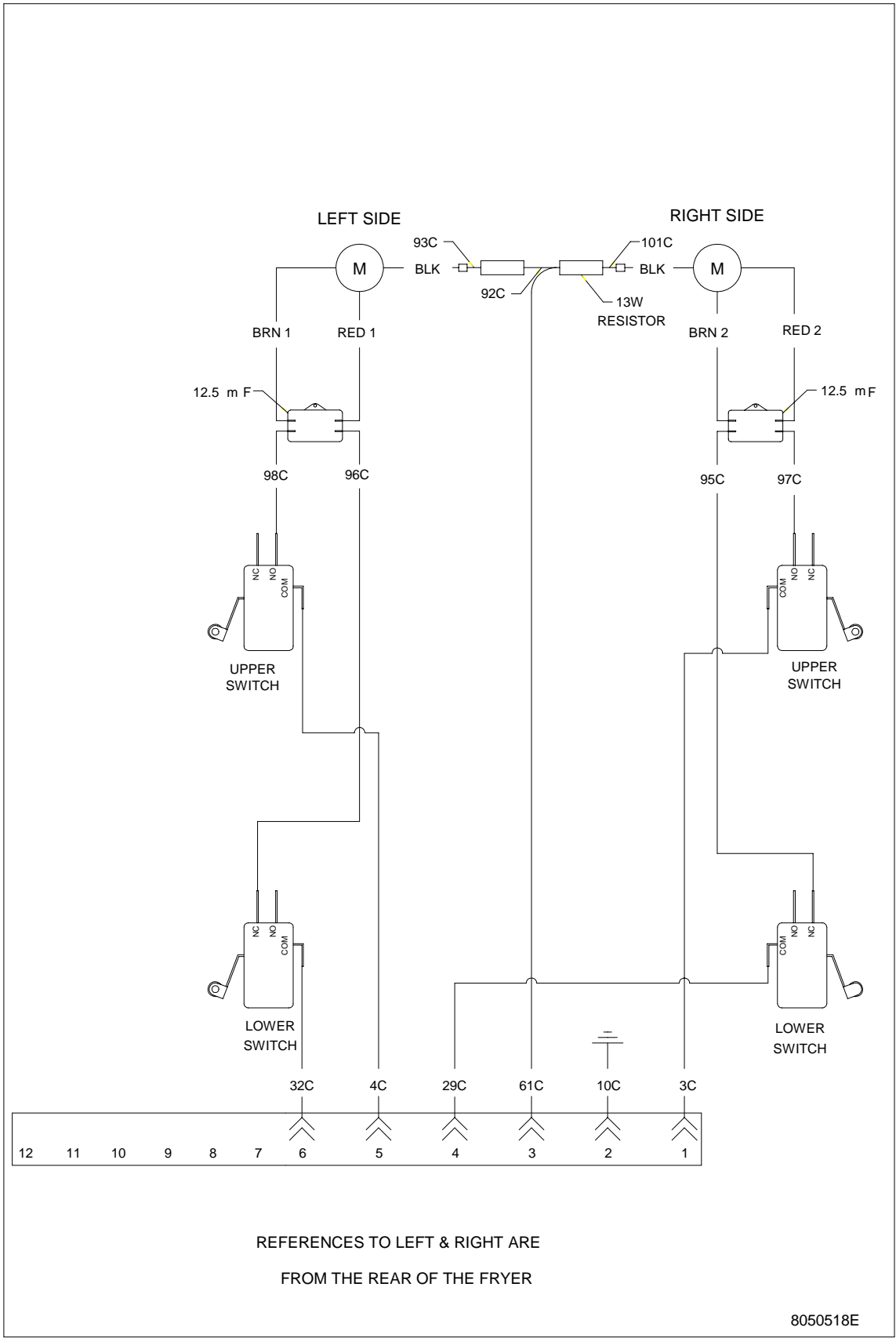

8050518E

**Modular Basket Lift – 208/250V (NOTE: This diagram is used for both CE and Non-CE applications.)**

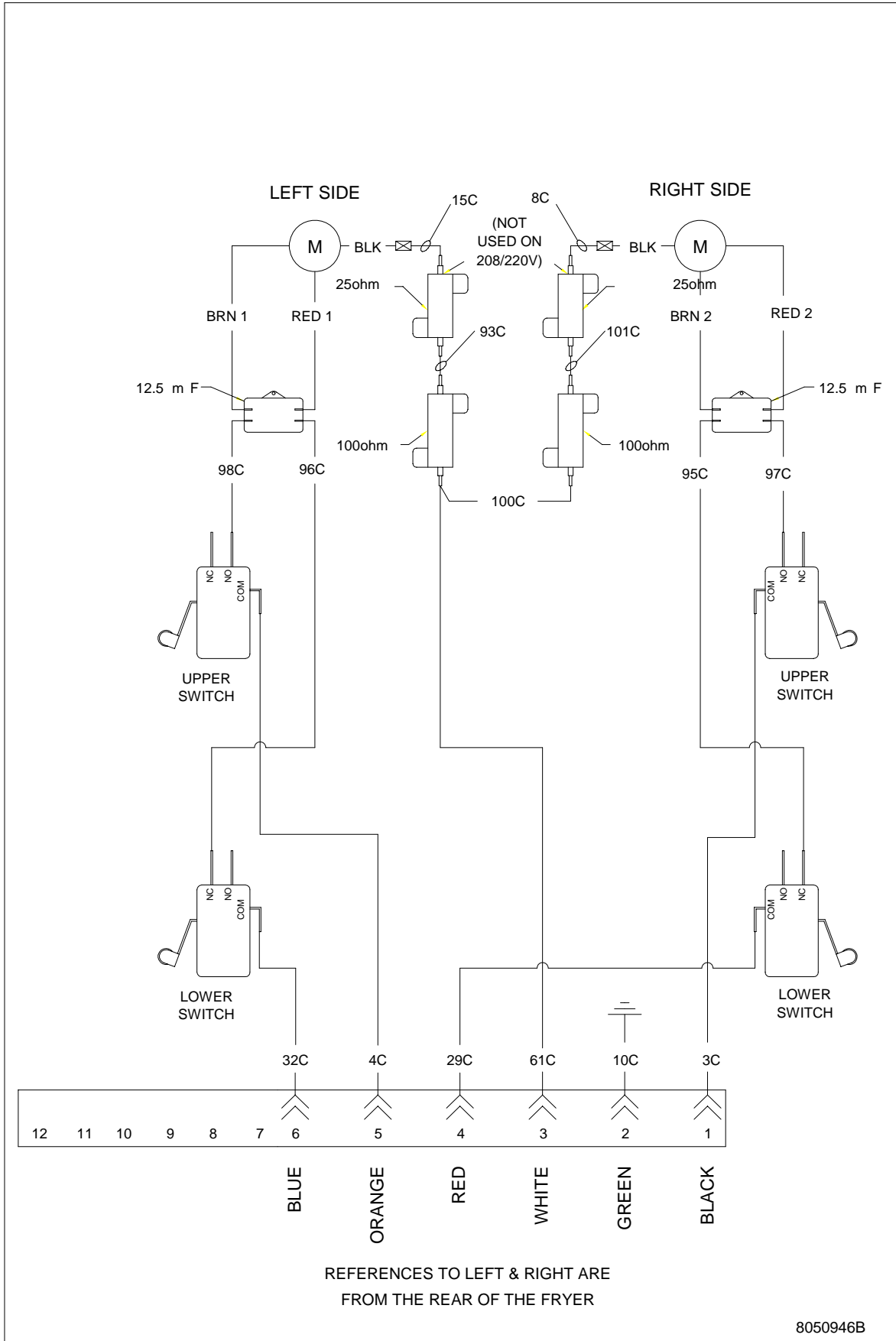

**Bell Crank Basket Lift (NOTE: There is no CE version of this option.)**

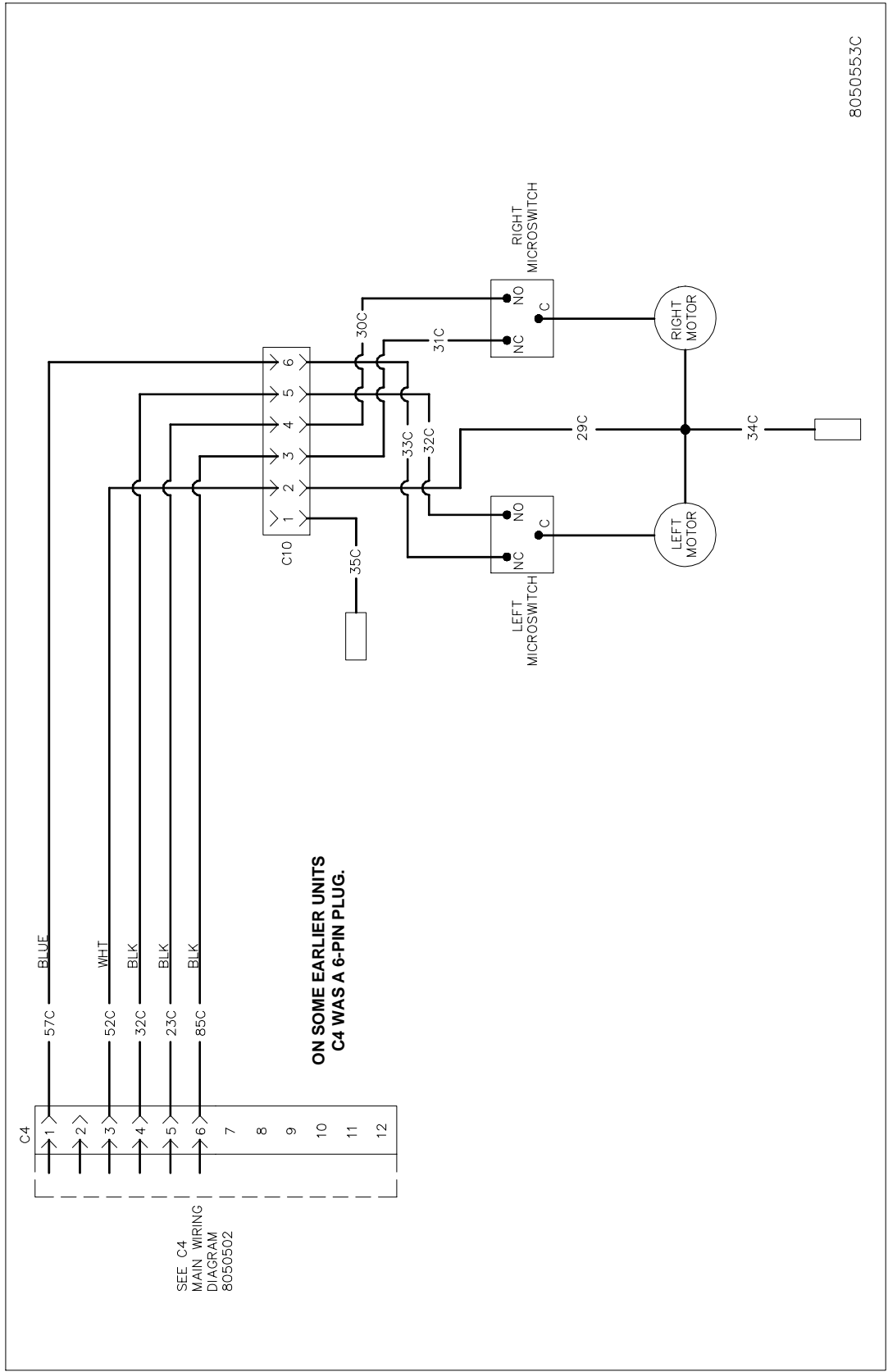

8050553C

## 1.14 WIRING DIAGRAMS – FILTER BOXES

FootPrint III Prior to August 1997 (NOTE: This diagram is used for both CE & Non-CE applications.)

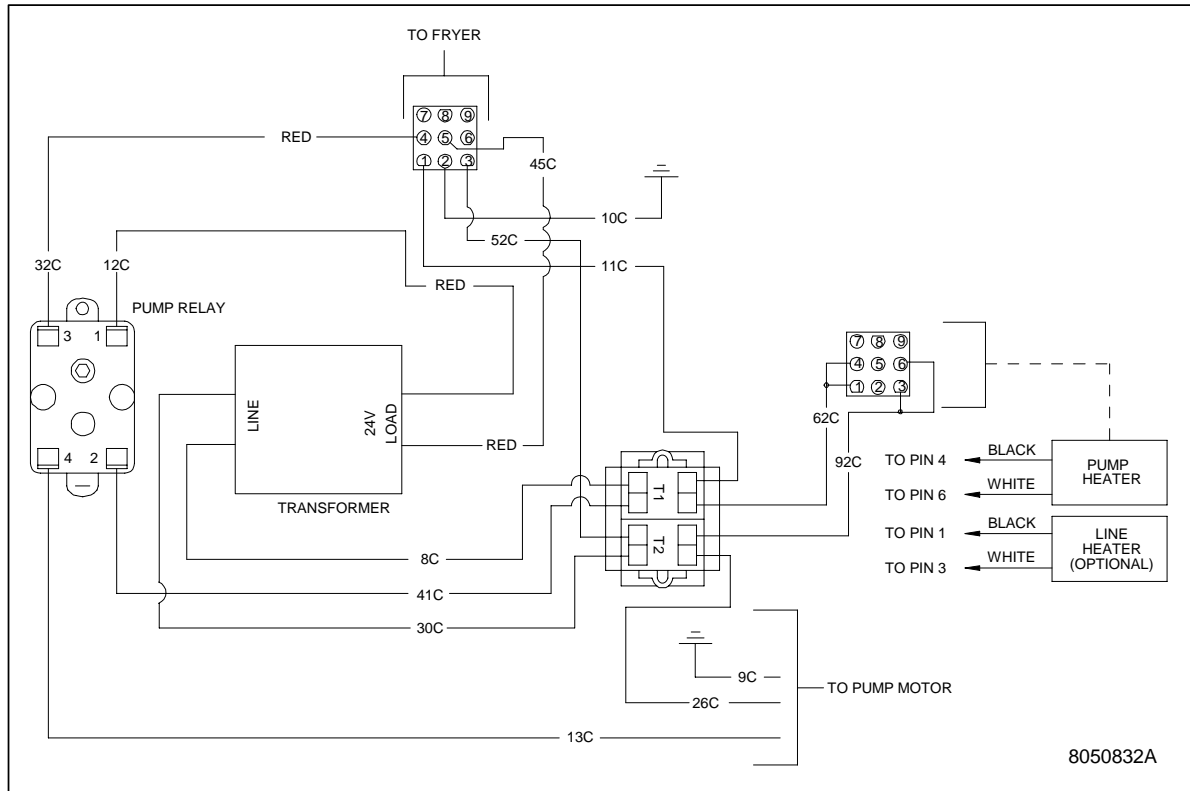

FootPrint III August 1997 and Later (NOTE: This diagram is used for both CE & Non-CE applications.)

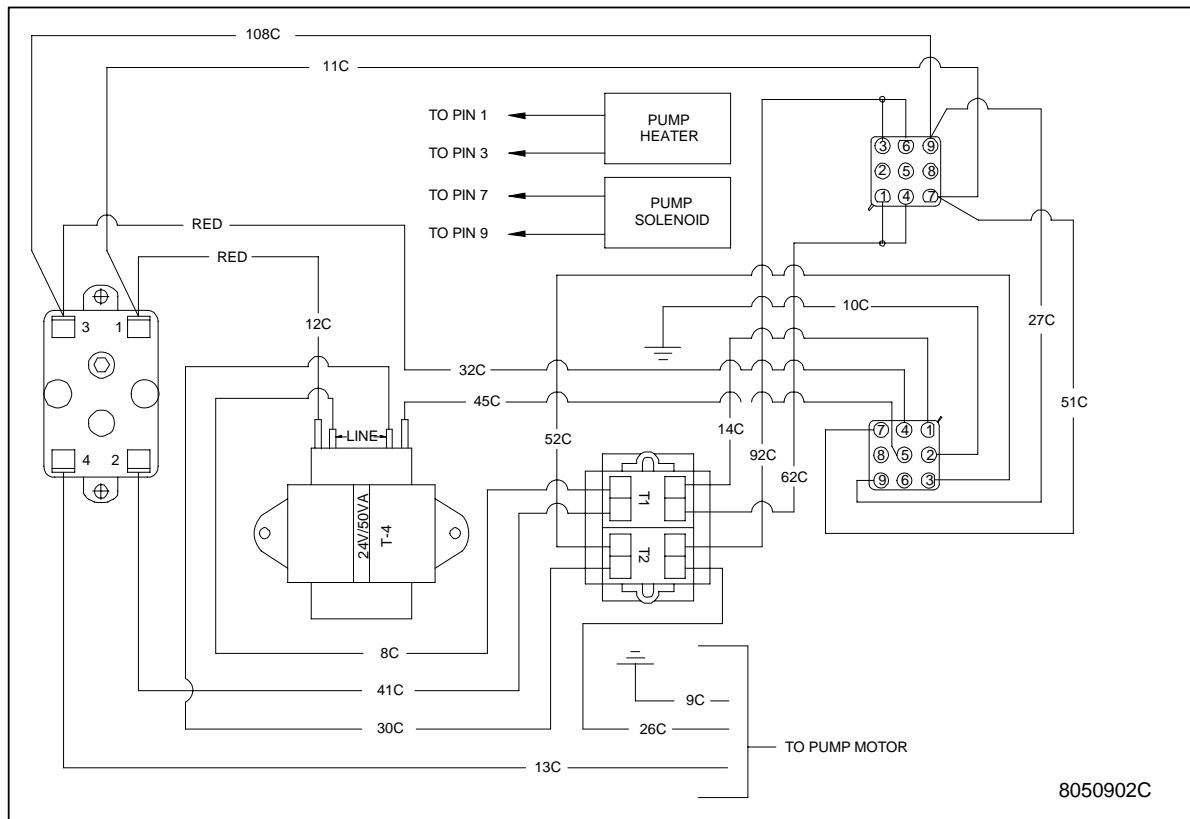

**Filter Magic II (NOTE: This diagram is used for both CE and Non-CE applications.)**

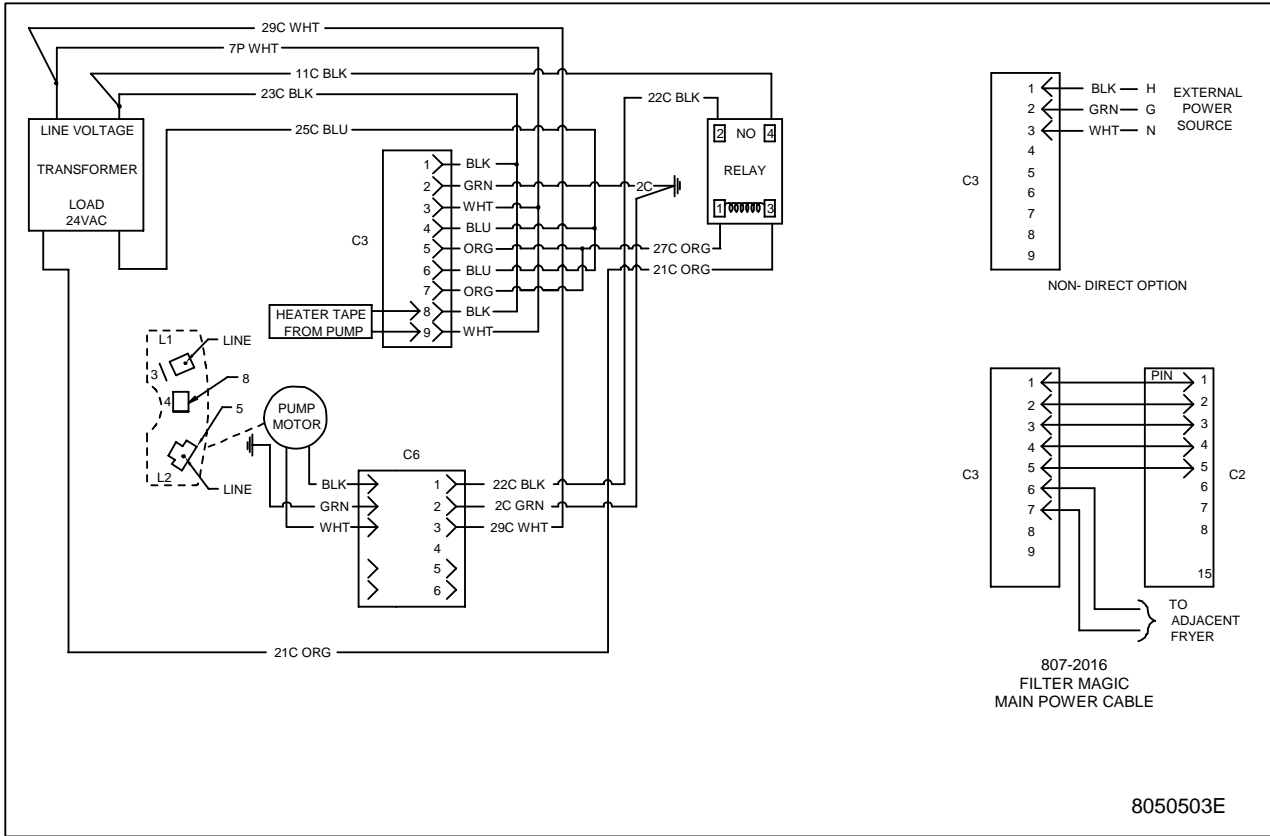

**1.15 WIRING DIAGRAMS – OIL RETURN**

**Oil Return/Disposal Wand Wiring (Japan/Lotteria)**

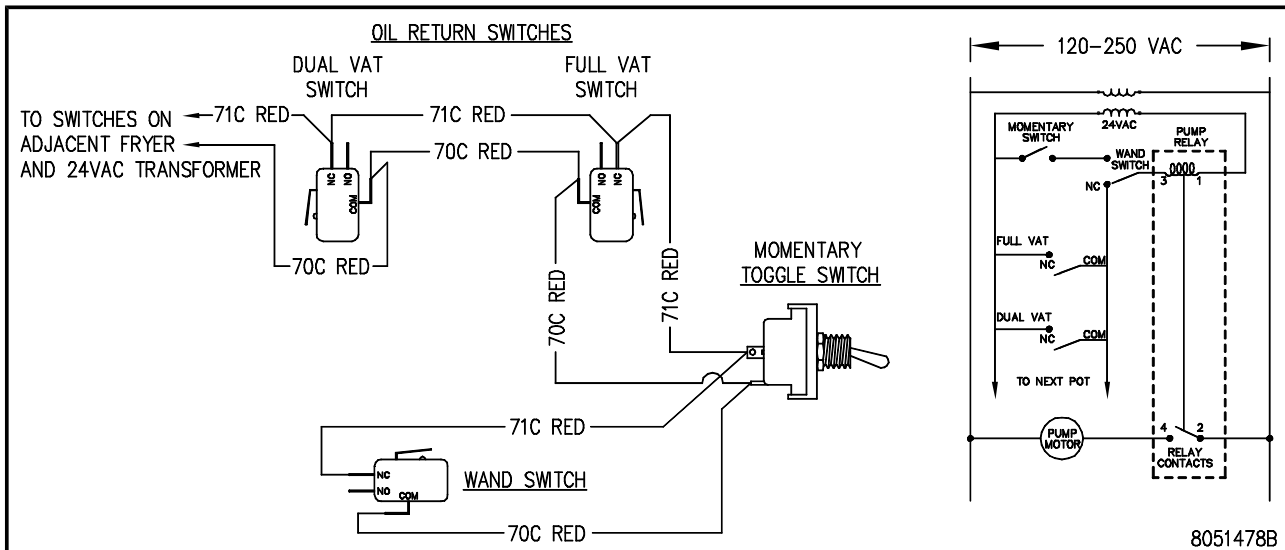

### Oil Return/Wand Wiring (Japan)

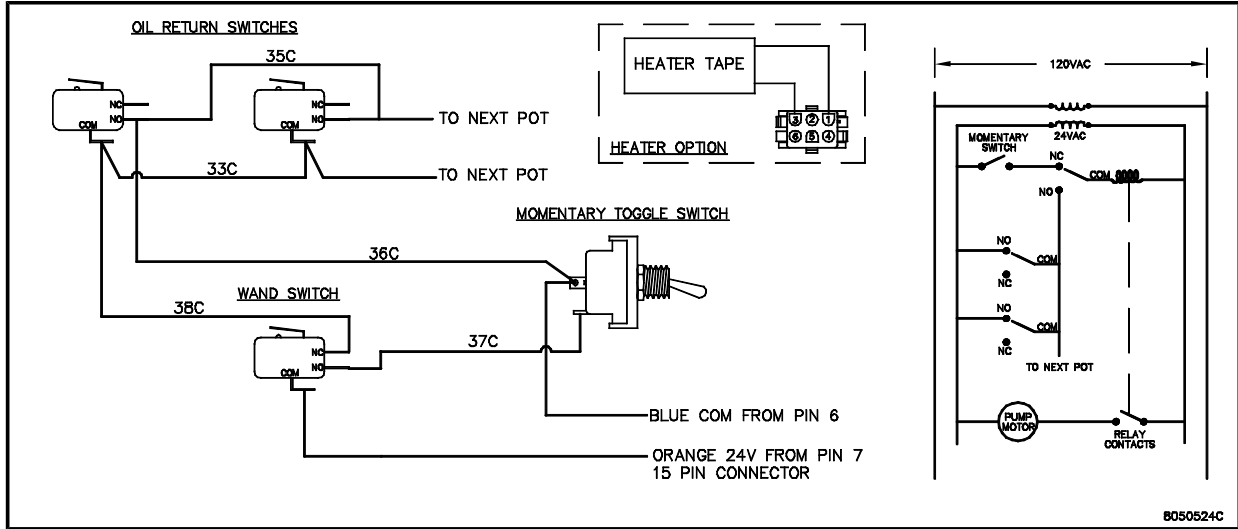

### Oil Return/Disposal Wand Wiring (Sonic)

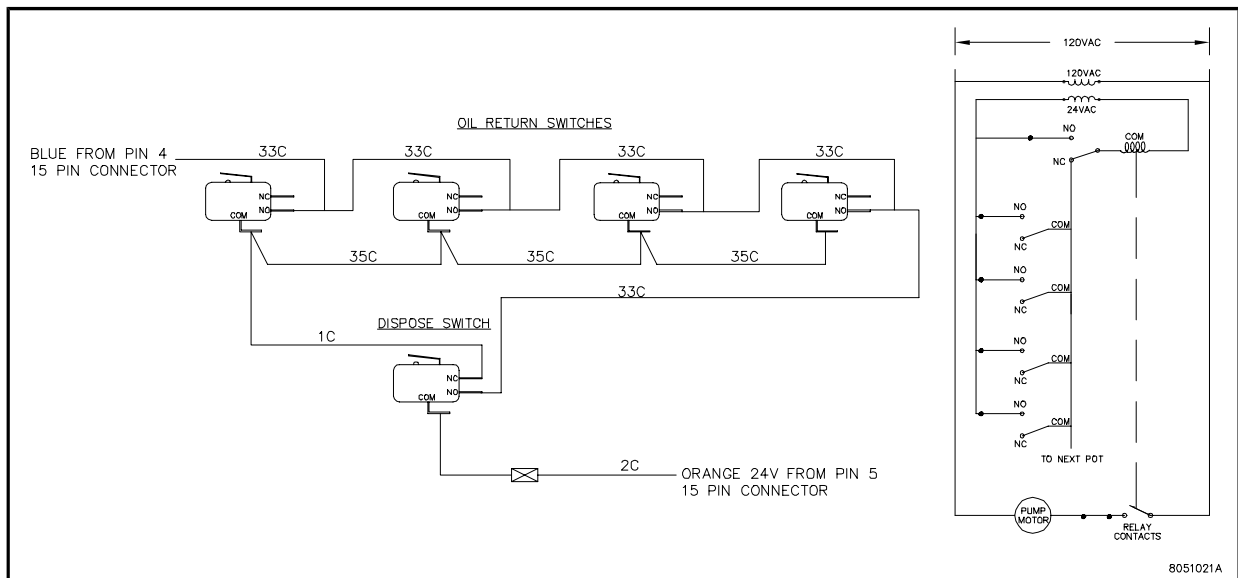

# H50 SERIES GAS FRYERS

## CHAPTER 2: PARTS LIST

### 2.1 Accessories

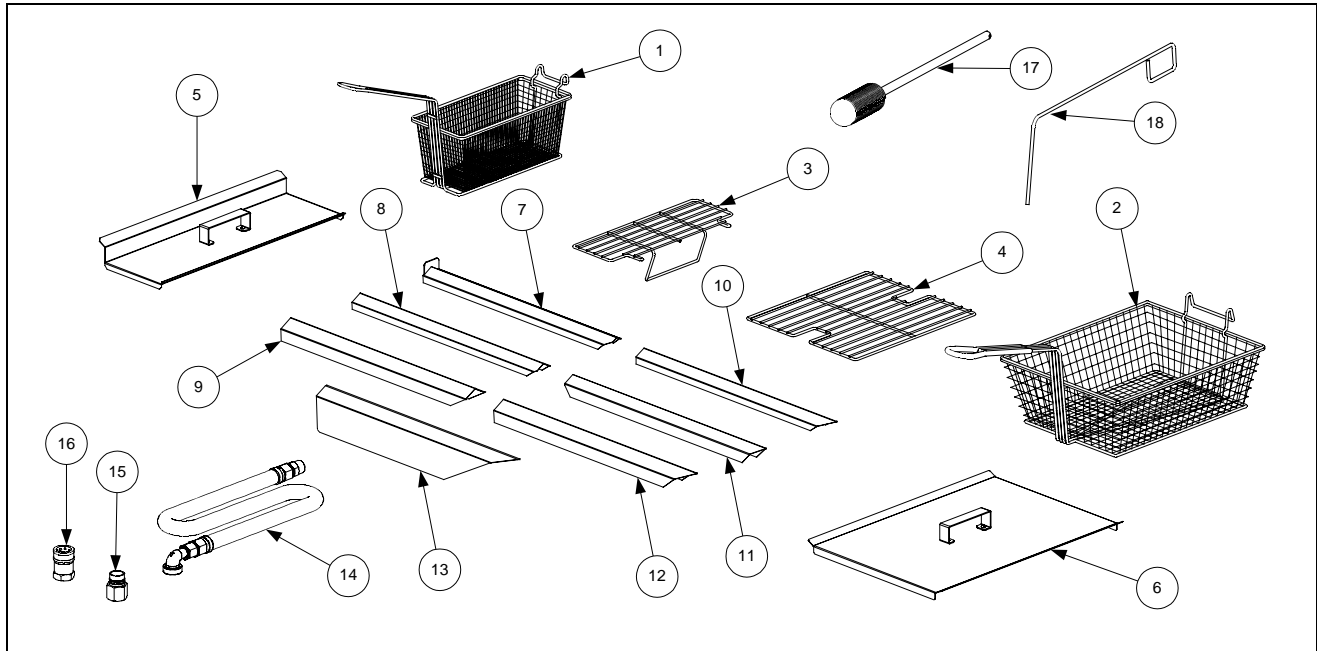

ITEM	PART #	COMPONENT
1	803-0271	Basket, Twin
2	803-0099	Basket, Full (cannot be used with basket lifts)
3	803-0133	Basket Support Rack, Dual Vat
4	803-0132	Basket Support Rack, Full Vat
*	803-0136	Basket Support Screen, Full Vat (screen w/handle used in place of Item 4)
5	806-3232	Cover, Frypot, Dual Vat
6	806-5518	Cover, Frypot, Full Vat
*	826-0993SP	Handle Kit, Frypot Cover (includes handle and screws)
7	823-1885	Connecting Strip w/back plate (Burger King only)
8	910-4617	Connecting Strip (blunt point, 1/2" sides, 20.70" long) –Applebee's Fryer to Filter
9	910-2285	Connecting Strip (blunt point, 1" sides, 20.80" long)- B.K. Wide
10	910-7515	Connecting Strip (sharp point, 1/2" sides, 21.73" long)- B.K. Dump Station to Fryer, Also Applebee's
11	910-7443	Connecting Strip (sharp point, 1" sides, 21.73" long)
12	910-7515	Connecting Strip (sharp point, 1" sides, 21.84" long)
13	910-2572	Connecting Strip (sharp point, 3" sides, 21.84" long)
14		Gas Line, 1-Inch Dormont Flexible (includes Items 15 and 16)
	806-1698	36-Inch (for gas line only (w/o Items 15 and 16), use 810-0088)
	806-1699	42-Inch (for gas line only (w/o Items 15 and 16), use 810-0085)

Continued on the following page



ITEM	PART #	COMPONENT
15	810-0074	Quick-Disconnect Fitting, 1-Inch Male
16	810-0073	Quick-Disconnect Fitting, 1-Inch Female
17	803-0209	Brush, Frypot Cleaning
18	803-0197	Fryer's Friend 27" (Clean-out Rod)
*	910-3557	Flue Deflector
*	810-1306	Valve, Manual Gas Shut Off 1/2"
*	810-1307	Valve, Manual Gas Shut Off 3/4"

\* Not illustrated.

**NOTE:** Sediment Trays: 803-0103 (Full-Vat), 803-0107 (Left Dual-Vat), and 803-0108 (Right Dual-Vat)

## 2.2 Basket Lift Assemblies and Component Parts

### 2.2.1 Bell Crank Basket Lifts

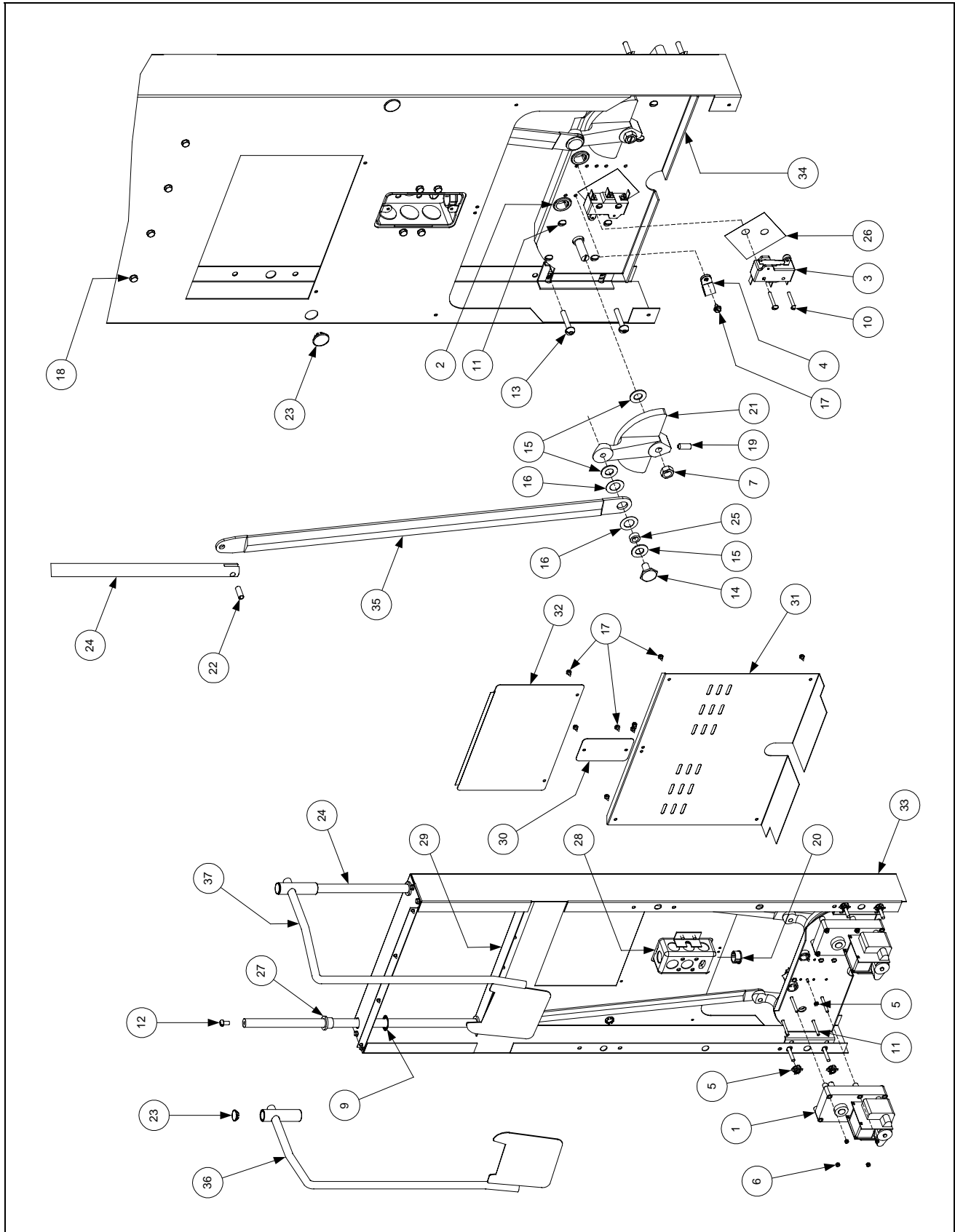

ITEM	PART #	COMPONENT
1		Gear Motor, Basket Lift
	807-0107	120VAC
	807-0108	240VAC
2	807-0124	Bushing, Plastic
3	807-0240	Microswitch
4	826-1680	Clamp, Plastic Wire (Pkg. of 8)
5	826-1358	Nut, 6-32 Hex (Pkg. of 25)
6	809-0050	Nut, 2-32 Hex
7	809-0063	Nut, Jam 3/8-16 Hex
8	809-0076	Nut, 1/4-20 x 3/4 Expansion
9	809-0082	Ring, Truarc Retaining
10	809-0097	Screw, 6-32 X 1-inch Slotted Truss Head
11	809-0113	Screw, 2-32 X 1 1/2-inch Slotted Truss Head- Req 2 + 2 (809-0503 Motor Mounts)
12	809-0127	Screw, 1/4-20 X 1/2-inch Slotted Round Head
13	826-1370	Screw, 1/4-20 X 1 1/4-inch Slotted Round Head (Pkg. of 10)
14	809-0155	Leveling Screw
15	809-0196	Washer, 3/8-inch Steel Flat
16	826-1381	Washer, Nylon (Package of 10 each 809-0203)
17	809-0360	Screw, 2-32 X 3/8-inch Slotted Hex Washer Head
18	826-1374	Screw, 10 X 1/2-inch Hex Washer Head (Pkg. of 25)
19	809-0480	Setscrew, 1/4-28 X 5/8-inch Hex Socket Head
20	810-0045	Bushing, Plastic
21	810-0052	Bellcrank and Cam
22	810-0170	Pin, Connecting
23	810-0172	Plug, 5/8-inch Hole S/S
24	810-0192	Rod, Basket Lift
25	810-0220	Spacer, Tubular
26	812-0138	Insulation, Paper (Fishpaper)
27	813-0035	Bushing, Bronze
28	823-1419	Box, Electrical Wiring
29	900-4110	Angle, Bearing Support
30	910-0119	Cover, Electrical Wiring Box
31	910-3177	Panel, Stainless Steel Rear Access (for mild steel, use 900-3177)
32	910-3783	Cover, Stainless Steel Rear Cabinet (for mild steel, use 900-3783)
33	910-9361	Housing, Basket Lift Stainless Steel (for mild steel, use 900-9361)
34	920-3233	Plate, Basket Lift Motor Mounting
35	920-6076	Link, Basket Lift
36	823-06931	Basket Lift Arm, Left
37	823-06932	Basket Lift Arm, Right
	810-0172	Plug Button SS 5/8" Hole
*	806-2078	Wiring Harness, Basket Lift Power (6-pin male w/5 wires)
*	806-2079SP	Wiring Harness, Basket Lift Motor (6-pin female w/7 wires)
*	806-7019SP	Wiring Harness, Non-Modular Basket Lift (6-pin male & female w/5 wires)
*	807-2000	Wiring Harness, H50 B/L Connecting (15-pin male & female w/13 wires)
*	807-3695	Cable, H50 Basket Lift (15-pin male & 12-pin male w/6 wires) C2 to C4
*	807-2033	Cable, H50 Basket Lift (15-pin male & 6-pin male w/ 6 wires ) Older cable

\* Not illustrated.

## 2.2.2 Modular Basket Lifts

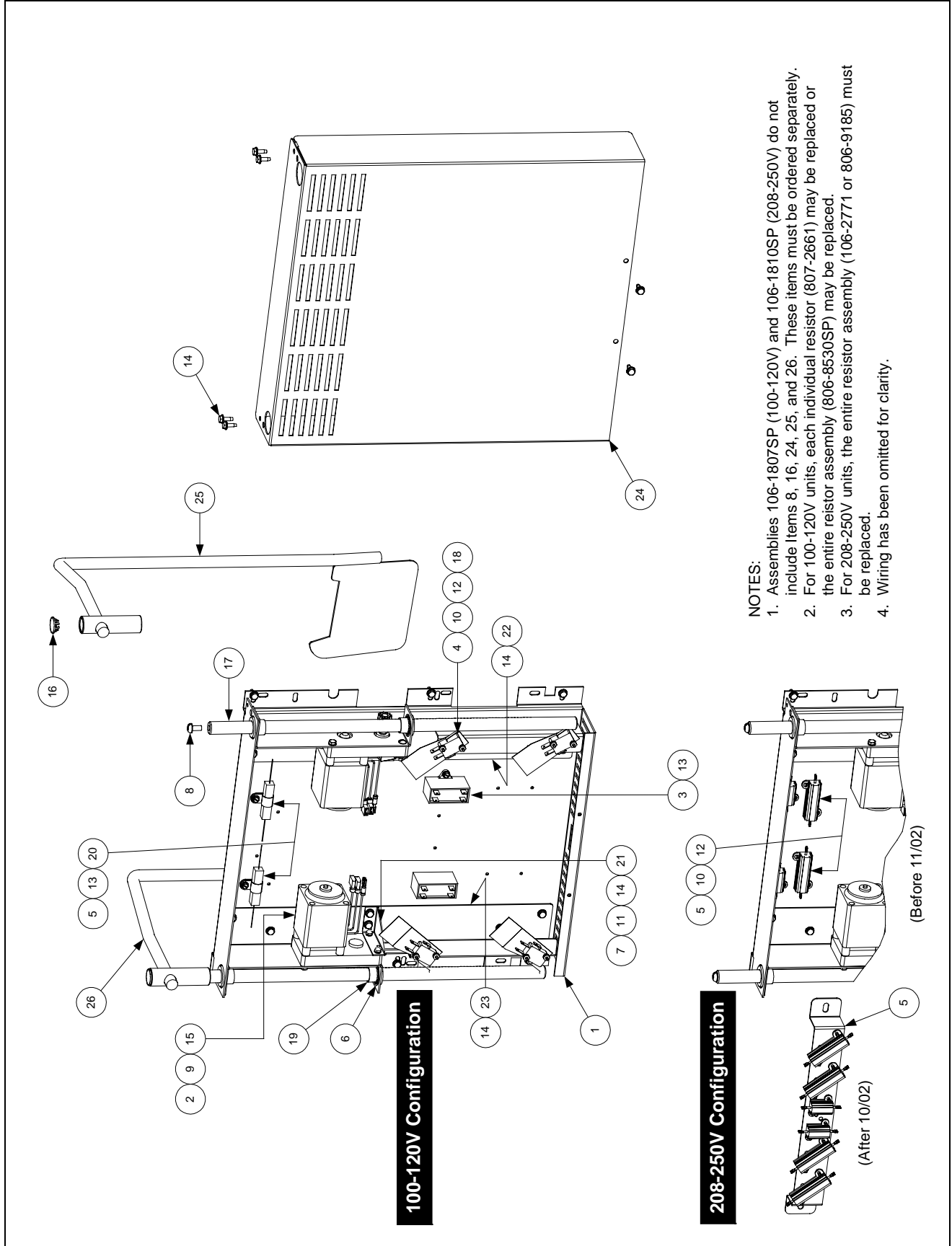

ITEM	PART #	COMPONENT
1		Mount, Modular Basket Lift**
	200-2942	For use on units with 12-pin connectors
	900-7655	For use on units with 6-pin connectors
2	806-5964SP	Motor Assembly, Modular Basket Lift
	810-1013	Gear, Modular Basket Lift ( <i>809-0504 Set Screw, 6-32 x .185</i> )
3	807-2513	Capacitor, 12.5 µFarad, 250VAC Motor Run
4	807-2572	Microswitch
5		Resistor Assembly
	806-8530SP	100-120V Modular Basket Lift (see Note 2 in illustration) <i>807-2661 Resistor only</i>
CE	106-2771	208-250V Modular Basket Lift (before 11/02 use 806-9185; see Note 3)
6	809-0082	Ring, Truarc Retaining
7	826-1361	Screw, 2-32 X 1-inch Slotted Truss Head (Pkg. of 25)
8	809-0127	Screw, ¼-20 X ½-inch Slotted Round Head
9	809-0186	Lock Washer w/External Teeth, #8
10	826-1366	Nut, 4-40 Hex Keps (Pkg. of 25)
11	809-0247	Nut, 2-32 Hex Keps
12	826-1359	Screw, 4-40 X ¾-inch Slotted Round Head (Pkg. of 25)
13	826-1371	Screw, #8 X ½-inch Hex Head Drill Point (Pkg. of 25)
14	826-1374	Screw, #10 X ½-inch Hex Head (Pkg. of 25)
15	809-0503	Screw, 2-32 X ½-inch Hex Head
16	810-0172	Plug, ⅝-inch Stainless Steel Hole
17	810-1012	Rod, Modular Basket Lift
18	812-0442	Insulation, Microswitch
19	813-0035	Bushing, Bronze, .640" ID
20	816-0033	Tie Wrap, Screw Mount
21	900-5529	Gusset, Modular Basket Lift Motor
22	901-8499	Chassis, Modular Basket Lift, Left
23	902-8499	Chassis, Modular Basket Lift, Right
24	910-4776	Cover, S/S Modular Basket Lift (for CRS cover use 900-4776)
	826-1991	Cover, Kit S/S Modular Basket Lift with screws
25	823-06931	Arm Rod Assembly, Left Basket Lift
26	823-06932	Arm Rod Assembly, Right Basket Lift
*		<b>Connector, Panel Mount**</b>
	807-0159	12-pin
	807-0158	6-pin
		<b>Wire Assemblies**</b>
*	806-9014SP	For 100-120V Modular Basket Lift w/6-Pin Connector
*	806-8555SP	For 202-250V Modular Basket Lift w/6-Pin Connector
*	106-1822SP	For 100-120V Modular Basket Lift w/12-Pin Connector
*	106-1804SP	For 202-250V Modular Basket Lift w/12-Pin Connector
		<b>Basket Lift Assemblies</b> (see Note 1 in illustration)
*	106-1807SP	100-120V w/o Relay
*	106-1810SP	202-250V w/o Relay

\* Not illustrated.

\*\* Basket lift assemblies manufactured prior to February 2002 have 6-pin connectors; those manufactured February 2002 and later have 12-pin connectors. Verify the type of connector in use before ordering wiring assemblies or mounts.

## 2.3 Blower Assemblies and Associated Components

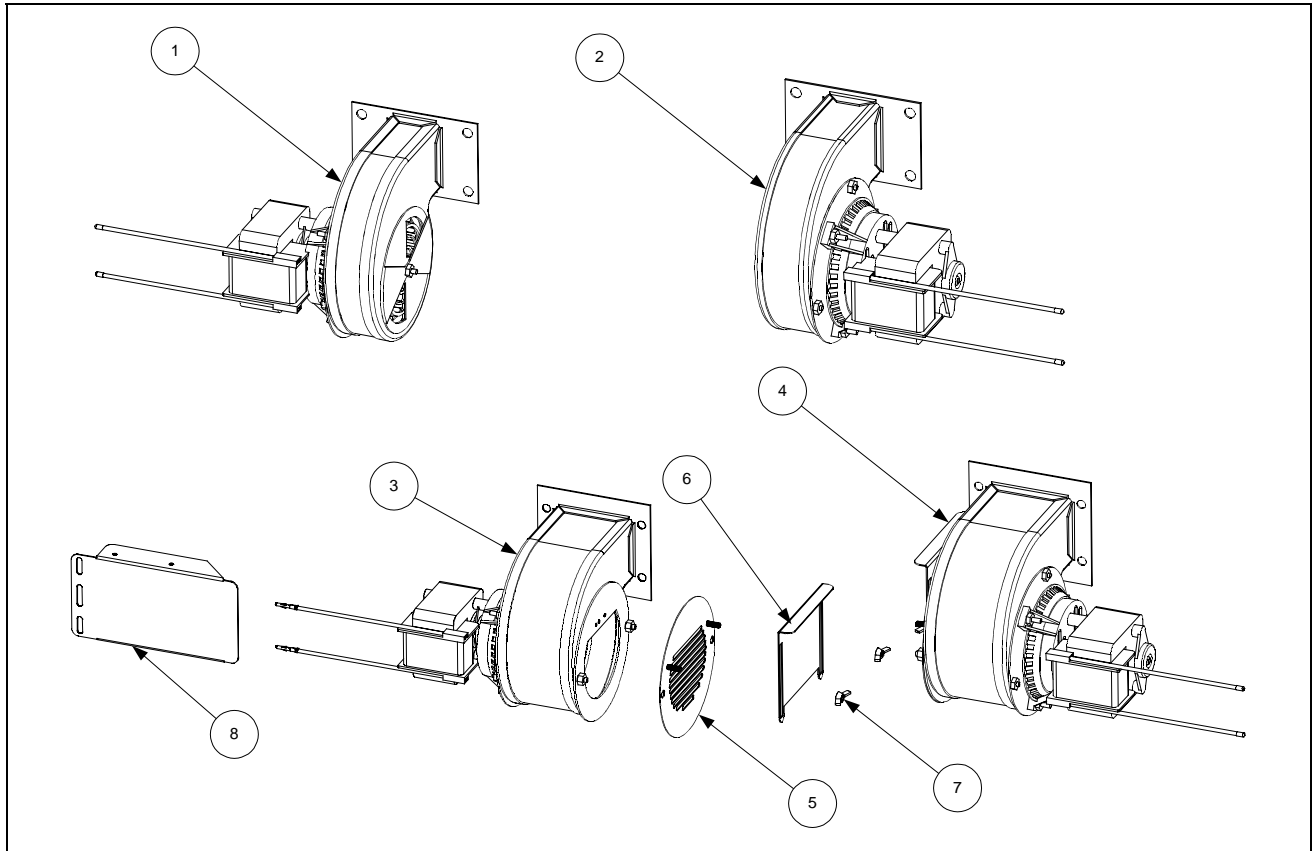

ITEM	PART #	COMPONENT
1		Blower, Left (with 1.54-inch (3.91 cm) narrow housing)
	106-2996SP	100V, 50/60 Hz
	106-2994SP	115V, 50/60 Hz
	806-5841SP	230V, 50 Hz
	106-2995SP	240V, 50 Hz
2		Blower, Right (with 1.54-inch (3.91 cm) narrow housing)
	806-4697SP	100V, 50/60 Hz
	106-2997SP	115V, 50/60 Hz
	807-7060SP	230V, 50 Hz
	106-2998SP	240V, 50 Hz
3	106-3000SP	Blower, Assembly Left, 230V, 50/60 Hz (with 2.2-inch (7.11 cm) wide housing) non-CE and CE
	106-3002SP	Blower, Assembly Left, 24V, 50/60 Hz (with 2.2-inch (7.11 cm) wide housing) non-CE and CE
4	106-3001SP	Blower, Assembly, Right 230V, 50 Hz (with 2.2-inch (7.11 cm) wide housing) CE and non-CE
	106-3003SP	Blower, Assembly, Right 24V, 50 Hz (with 2.2-inch (7.11 cm) wide housing) CE and non-CE
	106-3000SP	Blower Assembly, Left 230V, 50 Hz (CE)
5	806-9689	Finger Guard/Air Flow Inhibitor Adapter (CE)
6	900-8699	Air Flow Inhibitor (CE)
7	826-1382	Wingnut, 2-32 (Pkg. of 10)
8	826-1426	Shield, MH52 Blower Motor

Continued on the following page.

ITEM	PART #	COMPONENT
*	816-0554	Cover, Molded Plastic Blower Motor (fits left- or right-hand blowers)
*	809-0938	Screw, 10-32 X 5/8 Philips Truss Head (secures Blower Motor Cover to motor)
*	826-1383	Washer, 1/4-inch Flat (for mounting blower to plenum) (Pkg. of 5)
*	826-1372	Nut, 1/4-20 Hex (for mounting blowers to plenum) (Pkg. of 10)
*	KIT-0155SP	High Altitude Blower Kit (required above 5000 Ft, 1525 M)

\* Not illustrated.

**NOTES:** Items 5, 6, and 7 are components of Items 3 and 4. In CE units, they replace the rotating air shutter that is standard on 230V Blowers 106-3000SP and 106-3001SP (Items 3 and 4).

Blower Motor Cover P/N 816-0054 and Screw P/N 809-0938 are components of Items 1 through 4.

For Full Vat units, use Blower Assembly 106-2994SP (Non-CE) or 106-3000SP (CE). (Left Assembly.)

**Some earlier CE units were built with blowers having housings 1.54 inches (3.91 cm) wide. Current production CE-units are built with blowers having housings 2.71 inches (6.88 cm) wide. When ordering replacements for CE units, the width of the blower housing must be verified to ensure the correct blower is provided.**

**CE units built before June 1999 were equipped with a blower shield that completely covered the blower assemblies. This shield is no longer required and may be removed. The component parts of the shield are no longer available for replacement.**

## 2.4 Burner Ignition System Components and Associated Hardware

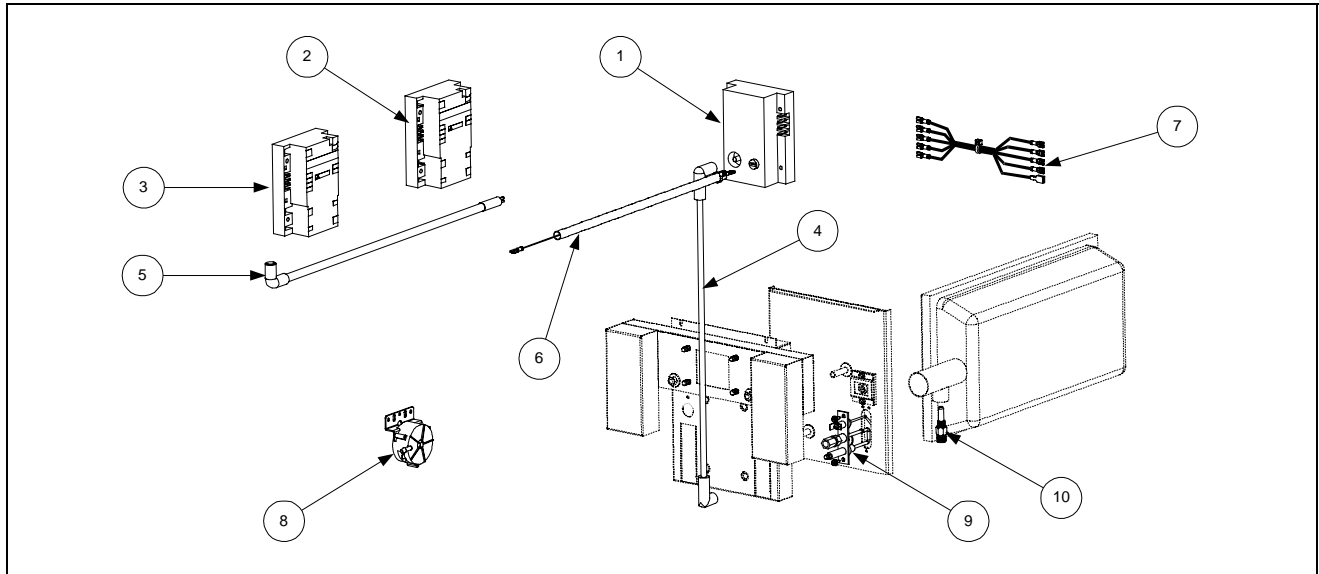

ITEM	PART #	COMPONENT
1	See Pg 2-19	Ignition Module, Full and Dual Vat (original design, with fuse) <i>807-0910 Fuse</i>
2	See Pg 2-19	Ignition Module, Full Vat (new design, without fuse)
*	826-1346	Spacer (Pkg. of 10)
3	See Pg. 2-19	Ignition Module, Dual Vat (new design, without fuse)
4		Ignition Cable
	807-1878	19-inches long (with two 90° connectors, used with Item 1 only)
	807-1200	27-inches long (with one 90° connector and one straight connector)
5	826-1721	Ignition Cable w/ Rajah (with one 90° connector, used with Items 2 and 3 only)
	807-3483	Cable, Ignition 21" (807-3484 Rajah Connector Only)
6	806-6085SP	Wire Assembly, Flame Sensor
7	806-6084SP	Wiring Assembly, Ignition Module
8	807-2263	Switch, Air Pressure ( <i>use 807-2262 in units with 100VAC power supply</i> )
*	KIT1428	CE Export Air Switch Kit
9		Ignitor and Gasket Kit (816-0059 Gasket Only)
	826-0981	Natural Gas (G20, G25)
	826-0982	Propane/Butane (G30, G31)
	826-1002	Manufactured Gas
10		Orifice
	812-1137	1.95 mm Propane/Butane (G30, G31) (0-4999 Ft, 0-1524 M) (CE)
	810-1221	2.00 mm Propane/Butane (0-4999 Ft, 0-1524 M) (Japan only)
	810-0386	2.10 mm Propane/Butane (0-4999 Ft, 0-1524 M)
	810-0413	2.16 mm Propane/Butane (G30, G31) (5000-6999 Ft, 1525-2133 M)
	812-1028	2.20 mm Propane/Butane (G30, G31) (7000-10,999 Ft, 2134-3352 M)
	812-1134	3.10 mm Natural Gas (G20, G25) (0-4999 Ft, 0-1524 M) (Japan only)
	810-0403	3.40 mm Natural Gas (G20, G25) (0-4999 Ft, 0-1524 M)
	810-0437	3.60 mm Natural Gas (G20, G25) (5000-6999 Ft, 1525-2133 M)
	812-1144	3.65 mm Natural Gas (G20, G25) (7000-8999 Ft, 2134-2743 M)
	812-1145	3.70 mm Natural Gas (G20, G25) (9000-10,999 Ft, 2744-3352 M)
	810-0642	5.95 mm Manufactured Gas (0-4999 Ft, 0-1524 M)
*	826-1196	Conversion Kit, Natural Gas (G20, G25) to Propane/Butane (G30, G31)
*	826-1197	Conversion Kit, Propane/Butane (G30, G31) to Natural Gas (G20, G25)

\* Not illustrated.



## 2.5 Cabinet Assemblies and Component Parts

### 2.5.1 FPH150 Cabinet Assembly

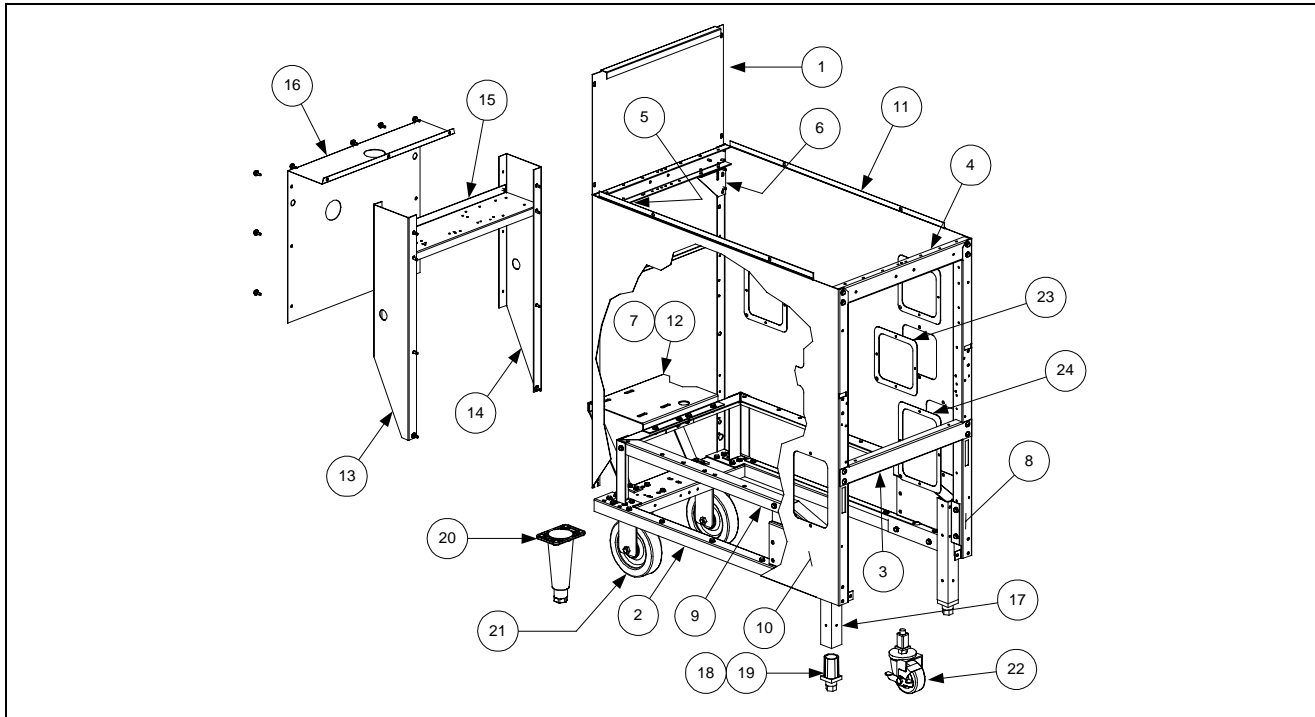

ITEM	PART #	COMPONENT
1	900-7448	Back, Cabinet
2	806-4897SP	Base Assembly ( <i>includes leg pad assembly 806-5209SP (see Page 2-13)</i> )
3	900-4391SP	Brace, Cabinet, Front
4	900-4813SP	Brace, Cabinet, Top
5	901-1405	Gusset, Left
6	902-1405	Gusset, Right
7	900-4551	Motor Mount
8	900-1621	Plate, Rail Mount (located inside lower front edge of Items 10 and 11)
9	806-5317SP	Rail Assembly
10	911-9324	Side, Cabinet, Stainless Steel, Left ( <i>use 901-9324SP for enameled cabinets</i> )
11	912-9324	Side, Cabinet, Stainless Steel, Right ( <i>use 902-9324SP for enameled cabinets</i> )
12	900-1786	Support, Motor Mount
13	902-7447	Rear Extension, Right Side
14	901-7447	Rear Extension, Left Side
15	900-4555	Bracket, Transformer Mounting
16	900-4558	Cover, Rear Extension
17	910-1601	Leg, Filter Cabinet ( <i>use 910-8673 on units with rear casters (Item 20)</i> )
	910-7925	Leg, 6" Single w/ Caster front ( <i>use w/ caster 823-2669 (White Castle)</i> )
18	810-0007	Leg, Adjustable (Inserts into Item 17)
19	910-1832	Retainer, Leg (Holds Item 18 in Item 17)
20	806-5043	Leg, 6" Adjustable
21	810-0750	Caster, 5" Rigid
22	823-2669	Caster, Single FootPrint front
23	910-0889	Cover, Access 5" x 5" SS for 4" x 4" Hole ( <i>use 900-0889 for enameled cabinets</i> )
24	910-0890	Cover, Access 5" x 7" SS for 4" x 6" Hole ( <i>use 900-0890 for enameled cabinets</i> )

## 2.5.2 FPH50 Batteries

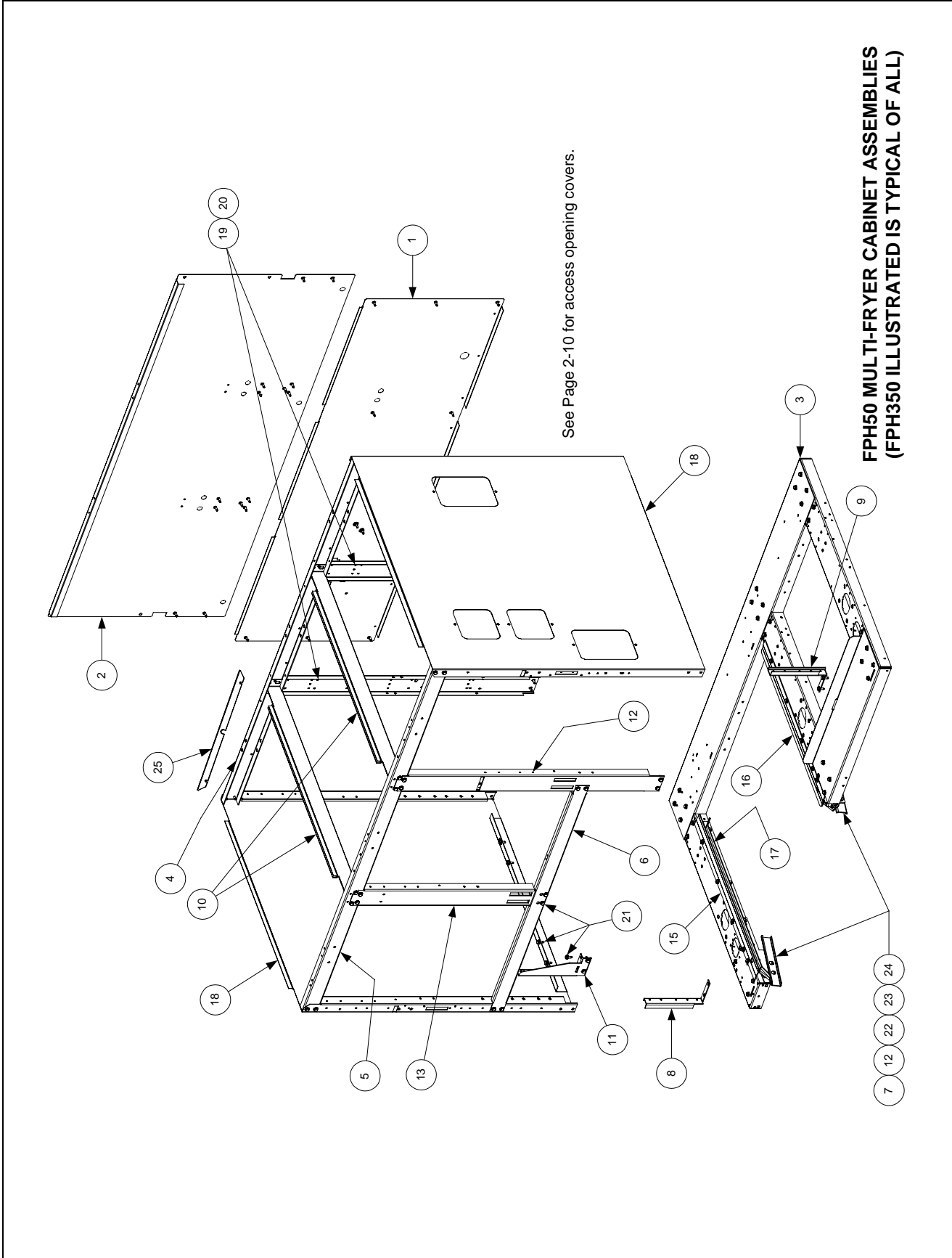

ITEM	PART #	COMPONENT
1		Back, Lower Cabinet
	910-7657	FPH250/FPH450 Stainless Steel ( <i>use 900-7657 for aluminized steel</i> )
	910-9416	FPH350 Stainless Steel ( <i>use 900-9416 for aluminized steel</i> )
2		Back, Upper Cabinet
	910-7658	FPH250/FPH450 Stainless Steel ( <i>use 900-7658 for aluminized steel</i> )
	910-9415	FPH350 Stainless Steel ( <i>use 900-9415 for aluminized steel</i> )
3		Base Assembly ( <i>includes leg pad assembly 806-5209SP (see Page 2-13)</i> )
	806-5861SP	FPH250
	806-5862SP	FPH350
	806-7085SP	FPH450
4		Brace, Cabinet Top, Rear
	900-7327SP	FPH250
	900-9352	FPH350
	900-2666SP	FPH450
5		Brace, Cabinet Top, Front
	900-7730SP	FPH250
	900-9430SP	FPH350
	900-9318	FPH450
6	900-7729	Brace, Cross Cabinet (not used on CE units)
7	900-1959	Bracket, Mounting
8	901-1948	Channel, Side Support, Left
9	902-1948	Channel, Side Support, Right
10	900-7326	Divider, Cabinet
11	901-1810	Gusset, Cabinet, Left
*	902-1810	Gusset, Cabinet, Right ( <i>used on FPH250 only</i> )
12	900-1957	Lock, Filter
13	900-7734	Post, Door, Long
14	900-4773SP	Post, Door, Short ( <i>use 900-2567 on CE units</i> )
15	911-4690	Rail, Filter, Top, Left
16	912-4690	Rail, Filter, Top, Right
17	910-5244	Rail, Filter, Universal
18		Side, Cabinet
	910-7678SP	Stainless Steel with no access openings
	900-7678SP	Enameled with no access openings
	912-7679	Stainless Steel with access openings ( <i>used on Filter Ready units only</i> )
	902-7679SP	Enameled with access openings ( <i>used on Filter Ready units only</i> )
19	809-0413	Spacer, Nylon
20	900-4815	Support, Cabinet Rear
21	826-1374	Screw, #10 X ½-inch Hex Washer Head (Pkg. of 25)
22	809-0422	Screw, 10-32 X 7/16-inch Slotted Truss Head
23	809-0189	Washer, ¼-inch Flat
24	809-0053	Nut, 10-32 Hex
25	900-4253	Flueclip Retainer
		Component Heat Shields
*	901-4314	Heat Shield Left
*	902-4315	Heat Shield Right
*	900-4833	Heat Shield Center

\* Not illustrated.

### 2.5.3 FH150, MJH150, and Spreader Cabinets

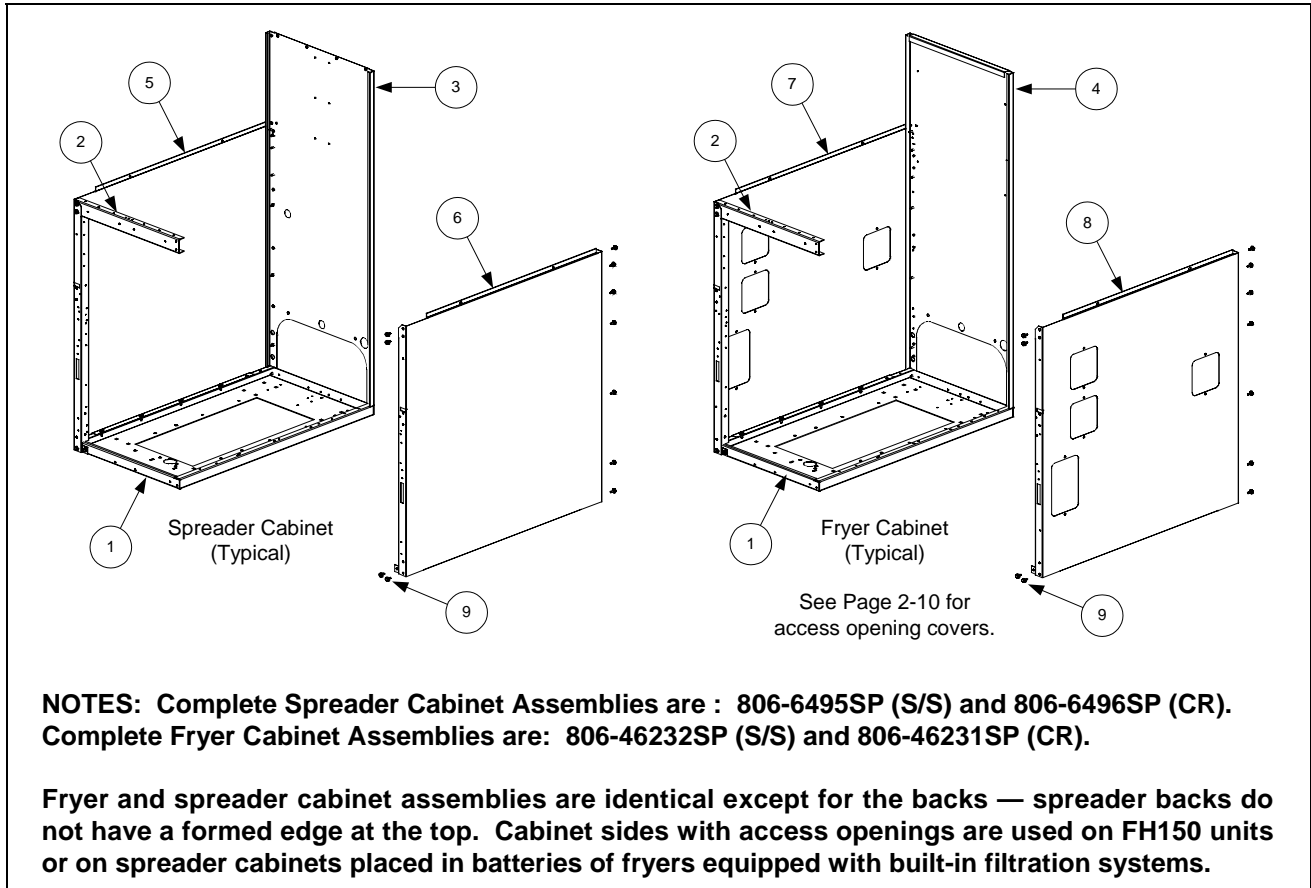

ITEM	PART #	COMPONENT
1	900-2568SP	Base, Cabinet, One-Piece
2	900-4813SP	Brace, Cabinet Top
3		Back, Spreader Cabinet
	910-6983SP	Stainless Steel
	900-6983SP	Aluminized Steel
4		Back, Fryer Cabinet
	910-7213SP	Stainless Steel
	900-7213SP	Aluminized Steel
5		Side, Left Cabinet w/o Access Openings
	911-9323SP	Stainless Steel
	901-9323SP	Enameled
6		Side, Right Cabinet w/o Access Openings
	912-9323SP	Stainless Steel
	902-9323SP	Enameled
7		Side, Left Cabinet w/Access Openings
	911-9324SP	Stainless Steel
	901-9324SP	Enameled
8		Side, Right Cabinet w/Access Openings
	912-9324SP	Stainless Steel
	902-9324SP	Enameled
9	826-1374	Screw, #10 X 1/2-inch Hex Washer Head (Pkg. of 25)

## 2.5.4 MJH50 Batteries

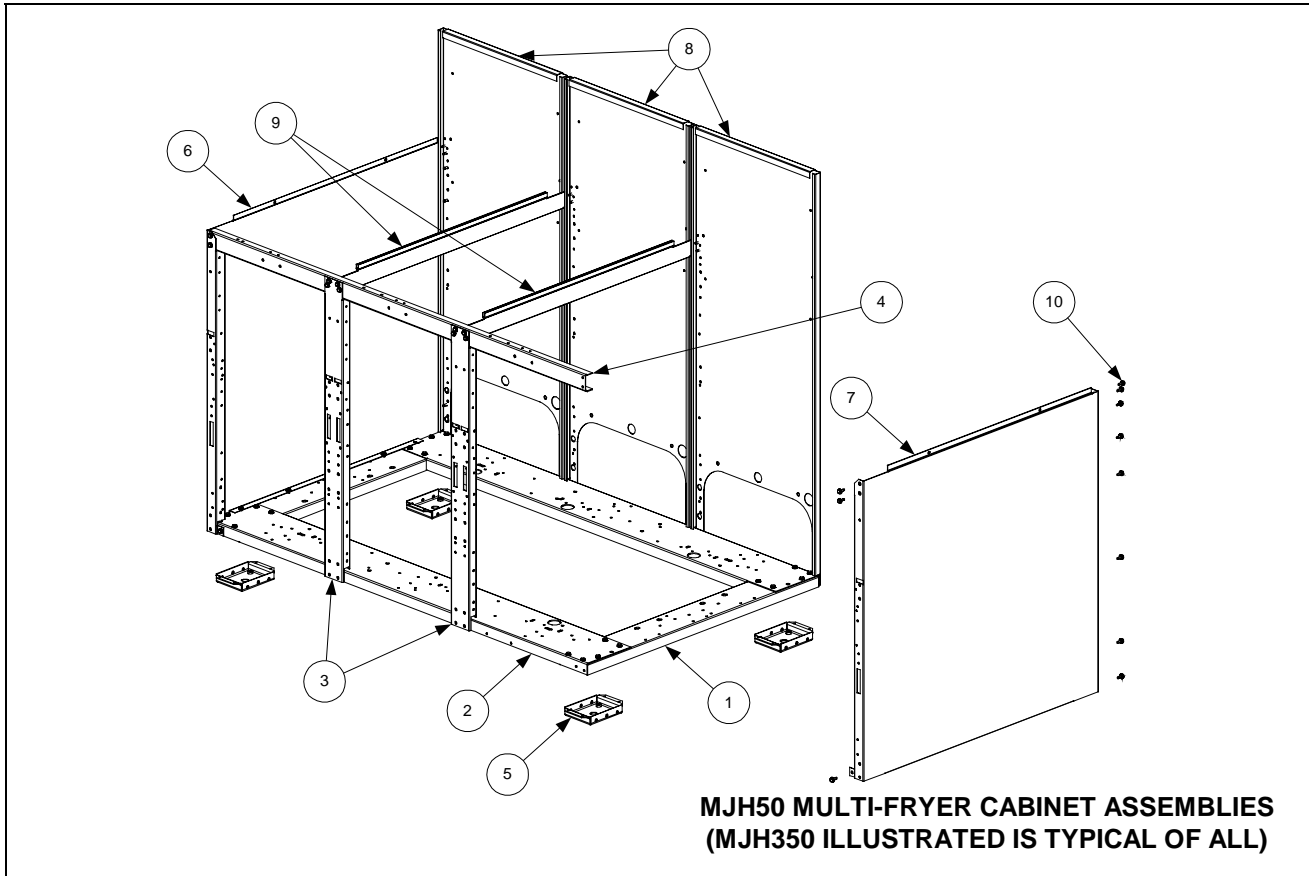

ITEM	PART #	COMPONENT
1	900-4426SP	Channel, Left and Right Side
2		Channel, Front and Rear
	900-2395SP	Double
	900-2396SP	Triple
	900-9373	Quad
3	900-6979SP	Post, Door
4		Brace, Cabinet Top
	900-7730SP	Double
	900-9430SP	Triple
	900-9318	Quad
5	806-5209SP	Leg Pad Assembly
6		Side, Left Cabinet
	911-9323SP	Stainless Steel ( <i>use 911-9324SP for side with access openings</i> )
	901-9323SP	Enameled ( <i>use 901-9324SP for side with access openings</i> )
7		Side, Right Cabinet
	912-9323SP	Stainless Steel ( <i>use 912-9324SP for side with access openings</i> )
	902-9323SP	Enameled ( <i>use 902-9324SP for side with access openings</i> )
8	900-6983SP	Back, Cabinet
9	900-7326	Divider, Cabinet
10	826-1374	Screw, #10 X 1/2-inch Hex Washer Head (Pkg. of 25)
*	826-1494	Kit, Jack in the Box Filter Magic Cold Air Block

\* Not illustrated.

## 2.5.5 FMH50 Batteries with Built-In Filtration

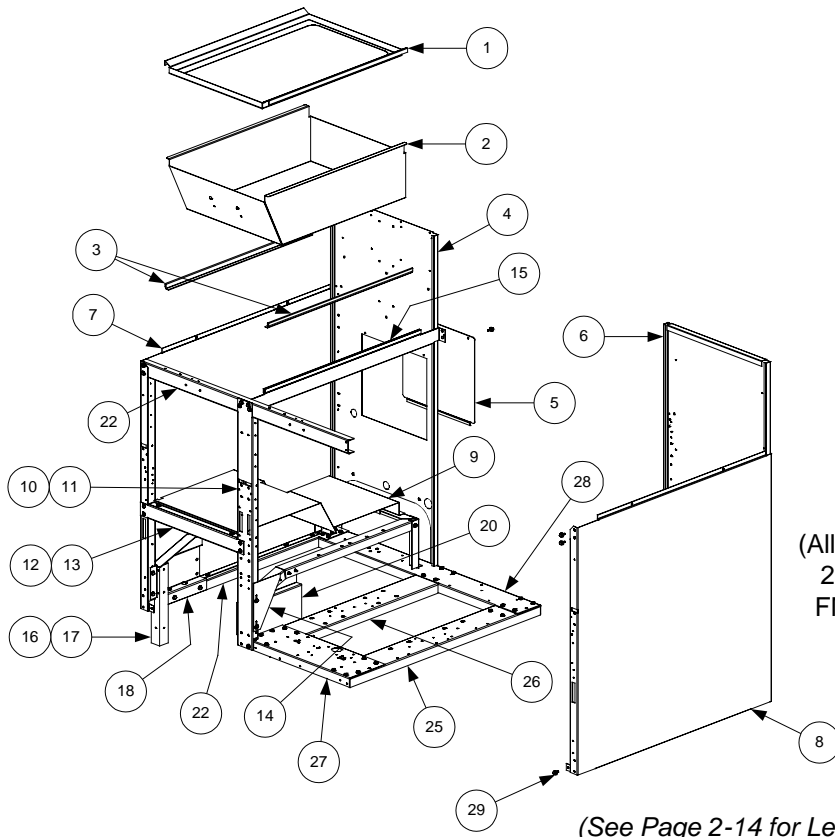

**NOTE:** Items 1-15 are used in all FMH50 Built-In Filter configurations and therefore are not repeated for the FMH250 and FMH150 (Filter on Right) illustrations.

**FMH150 (FILTER ON LEFT)**  
 (All components except Items 27 and 28 are the same for FMH250 and FMH350 units with the filter on the left.)

(See Page 2-14 for Leg Pad Assembly)

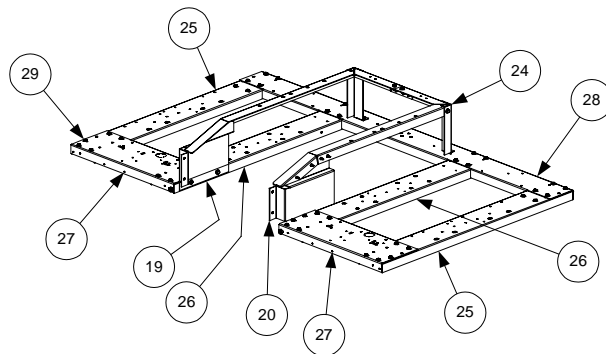

**FMH250 (FILTER BETWEEN FRYERS)**  
 (All components except Items 27 and 28 are the same for FMH350 cabinets with the filter between fryers.)

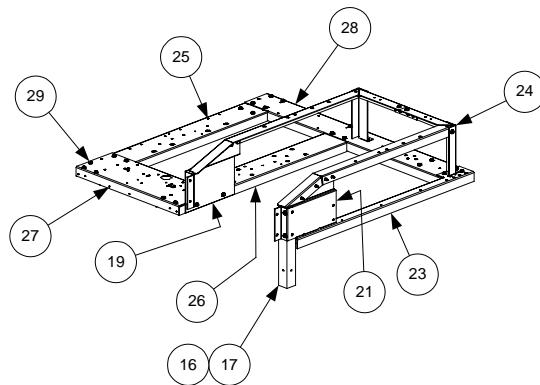

**FMH150 (FILTER ON RIGHT)**  
 (All components except Items 27 and 28 are the same for FMH250 and FMH350 units with the filter on the right.)

ITEM	PART #	COMPONENT
1	910-7480	Trim, Filter Cabinet Top
2	806-8274SP	Pan Assembly, Filter/Spreader Cabinet
3	900-7277	Support, Drain Pan
4		Back w/Access Opening, Filter Cabinet
	910-7274SP	Stainless Steel
	900-7274SP	Aluminized Steel
5	900-4089	Cover, Cabinet Back Access
6		Back, Cabinet
	910-6983SP	Stainless Steel
	900-6983SP	Aluminized Steel
7		Side, Left Cabinet
	911-9323SP	Stainless Steel
	901-9323SP	Enameled
8		Side, Right Cabinet
	912-9323SP	Stainless Steel
	902-9323SP	Enameled
9	900-7414	Shield, Filter Magic Pan
10	900-6979SP	Post, Door
11	809-0413	Spacer, .25 x .160 8 Gauge Nylon (located behind Item 10 at bottom)
12	900-4391SP	Brace, Front Cabinet
13	826-1379	Screw, #10 x ½-inch Philips Truss Head (package of 10)
14	900-1700	Bracket, Drain Support
15	900-7314SP	Divider, Cabinet
16	910-1601	Leg, Filter
17	900-1621	Plate, Rail Mount (located inside front edge of Item 7)
18	901-1599	Bracket, Left Pan Rail (used on cabinets with filter on left)
19	901-1595	Bracket, Left Pan Rail (used on cabinets with filter on right or in middle)
20	902-1599	Bracket, Right Pan Rail (used on cabinets with filter on right or in middle)
21	902-1595	Bracket, Right Pan Rail (used on cabinets with filter on right)
22	901-4390	Channel, Left Filter Side
23	902-4390	Channel, Right Filter Side
24	806-4917	Rail Assembly, Filter Magic
25	900-4426	Channel, Fryer Outside
26	900-4383	Channel, Fryer Inside
27		Channel, Fryer Front
	900-2394	Single Fryer
	900-2395	Double Fryer
	900-2396	Triple Fryer
28		Channel, Filter Magic Cabinet Rear
	900-1631	FMH150 Filter Left
	900-7243	FMH250 Filter Left
	900-9319	FMH350 Filter Left
	900-1630	FMH150 Filter Right
	900-7244	FMH250 Filter Right
	900-9322	FMH350 Filter Right
	900-7242	FMH250 Filter Middle
	900-9321	FMH350 (Fryer, Fryer, Filter, Fryer)
	900-9320	FMH350 (Fryer, Filter, Fryer, Fryer)
29	826-1374	Screw, #10 X ½-inch Hex Washer Head (Pkg. of 25)

## 2.5.6 Filter Magic Add-On Cabinetry

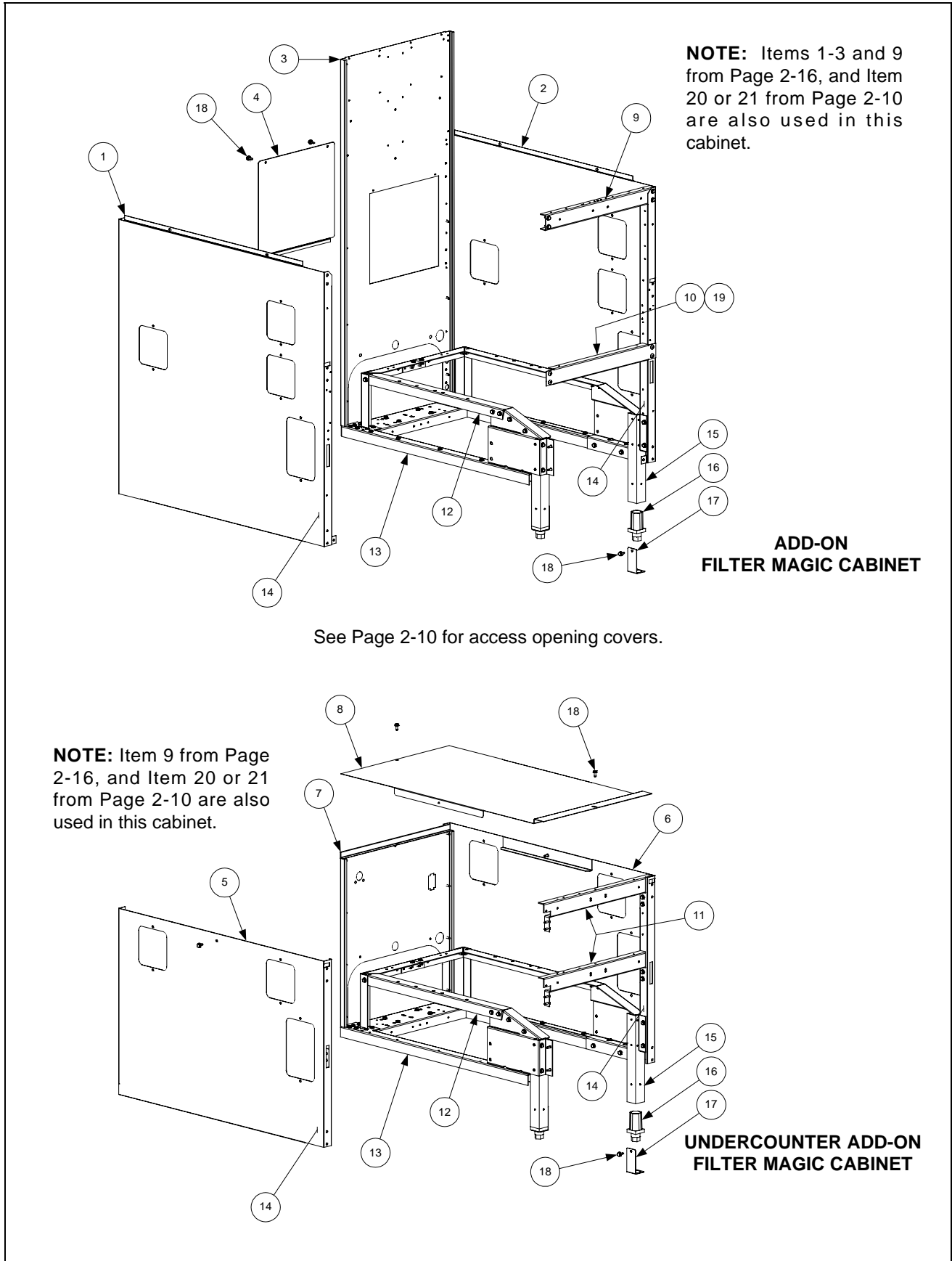



ITEM	PART #	COMPONENT
1		Side, Left Cabinet, w/Access Openings
	911-9324SP	Stainless Steel
	901-9324SP	Enameled
2		Side, Right Cabinet, w/Access Openings
	912-9324SP	Stainless Steel
	902-9324SP	Enameled
3		Back w/Access Opening, Filter Cabinet
	910-7274SP	Stainless Steel
	900-7274SP	Aluminized Steel
4	900-4089	Cover, Cabinet Back Access
5		Side, Left Undercounter Cabinet
	911-7677SP	Stainless Steel
	901-7677SP	Enameled
6		Side, Right Undercounter Cabinet
	912-7677SP	Stainless Steel
	902-7677SP	Enameled
7		Back, Undercounter Cabinet
	910-4786	Stainless Steel
	900-4786	Aluminized Steel
8	910-7680	Cover, Undercounter Cabinet
9	900-4813SP	Brace, Cabinet Top
10	900-4391SP	Brace, Cabinet Front
11	900-4785	Brace, Undercounter Cabinet Top and Center
12	806-5317SP	Rail Assembly
13	806-4897SP	Base Assembly ( <i>includes leg pad assembly 806-5209 (see Page 2-13)</i> )
14	900-1621	Plate, Rail Mount (located inside lower front edge of Items 1, 2, 5, and 6)
15	910-1601	Leg, Filter Cabinet ( <i>use 910-8673 on units with rear casters</i> )
16	810-0007	Leg, Adjustable
17	910-1832	Retainer, Leg Insert, Full Height
18	826-1374	Screw, #10 X ½-inch Hex Washer Head (Pkg. of 25)
19	826-1379	Screw, #10 X ½-inch Philips Truss Head (Pkg. of 10)
*	910-8503	Front Panel HE Filter Magic
*	802-0391	Label, FMII Control Panel
*	900-8906	Liner, Floor One Piece Base
*	901-1599	Bracket, Left Pan Rail Leg
*	902-1599	Bracket, Right Pan Rail Leg
*	910-0889	Cover, 4" Cabinet Side Hole S/S
*	910-0890	Cover, 7" Cabinet Side Hole S/S

\* Not illustrated

## 2.6 Casters, Legs, and Restraints

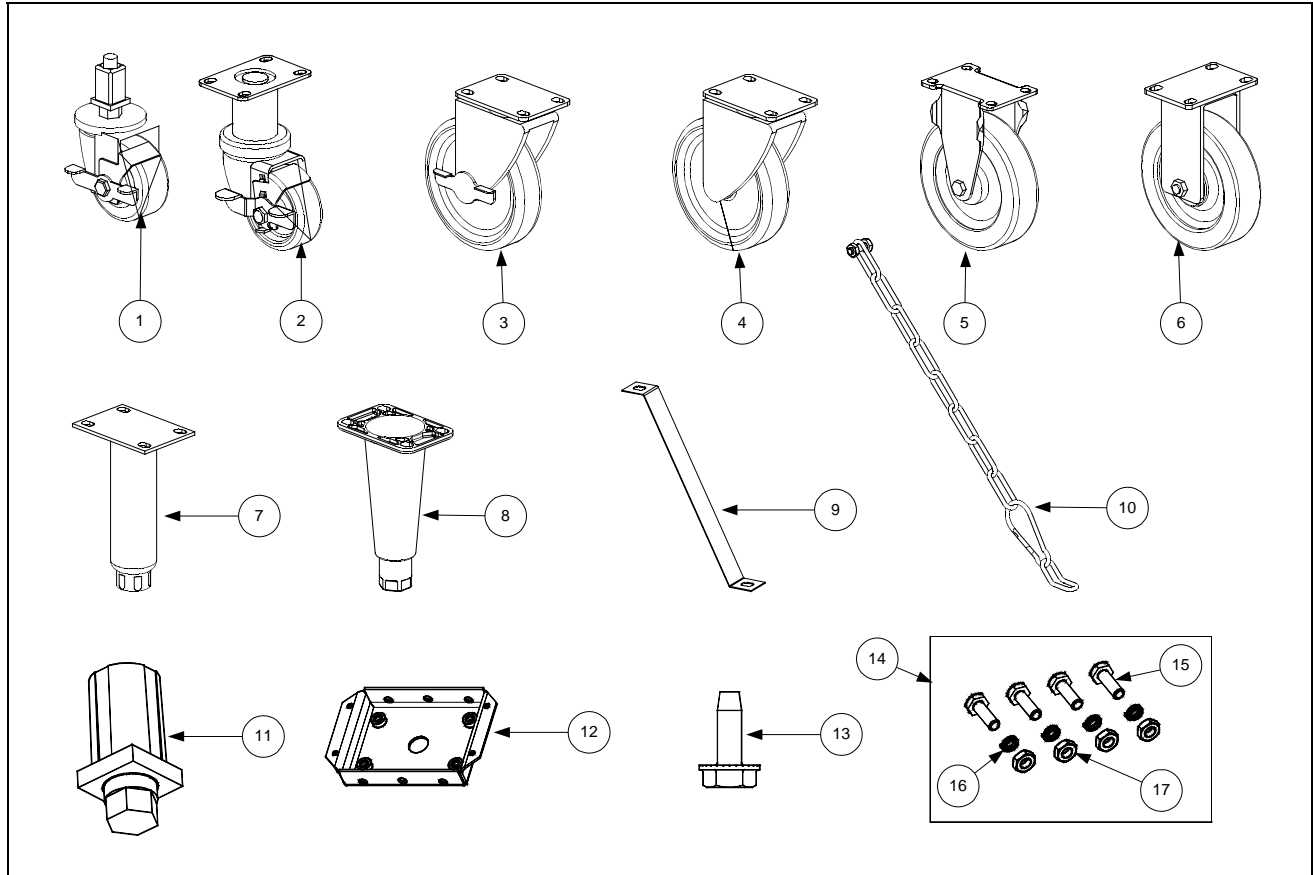

ITEM	PART #	COMPONENT
1	823-2669	Caster, Single FootPrint Front
*	910-7925	Mounting Leg for Caster 823-2669
2	826-1130	Caster, 3" Swivel w/Brake (810-0651)
3	826-1118	Caster, 5" Swivel w/Brake (810-0357)
4	826-1117	Caster, 5" Swivel w/o Brake (810-0356)
5	826-1138	Caster, 5" Rigid w/o Brake (810-0378)
6	826-1114	Caster, 5" Rigid w/o Brake (810-0750)
7	826-1237	Leg Assembly, Stainless Steel (810-1205)
8	826-1115	Leg Assembly, Nickel Plated (806-5043)
9	826-1095	Anchor Strap Kit (for use on single fryers w/legs)
10	826-0900	Chain Restraint Kit (for use on fryers w/casters)
11	810-0007	Leg, Square Tube
12	806-5209SP	Leg Pad (mounts with 826-1374)
13	826-1374	Screw, #10-1/2 HX Washer HD NP
14	826-1113	Caster Fastener Kit (One Caster)
15	826-1389	Screw, Hex Head 1/4-20 x 3/4
16	809-0191	Washer, 1/4 Lock Spring ZP
17	826-1362	Nut, 1/4-20 Hex

**NOTE:** Items 2 through 8 include 1 caster or leg, 4 mounting bolts, and 4 lock washers.

## 2.7 Component Box Assemblies and Associated Component Parts

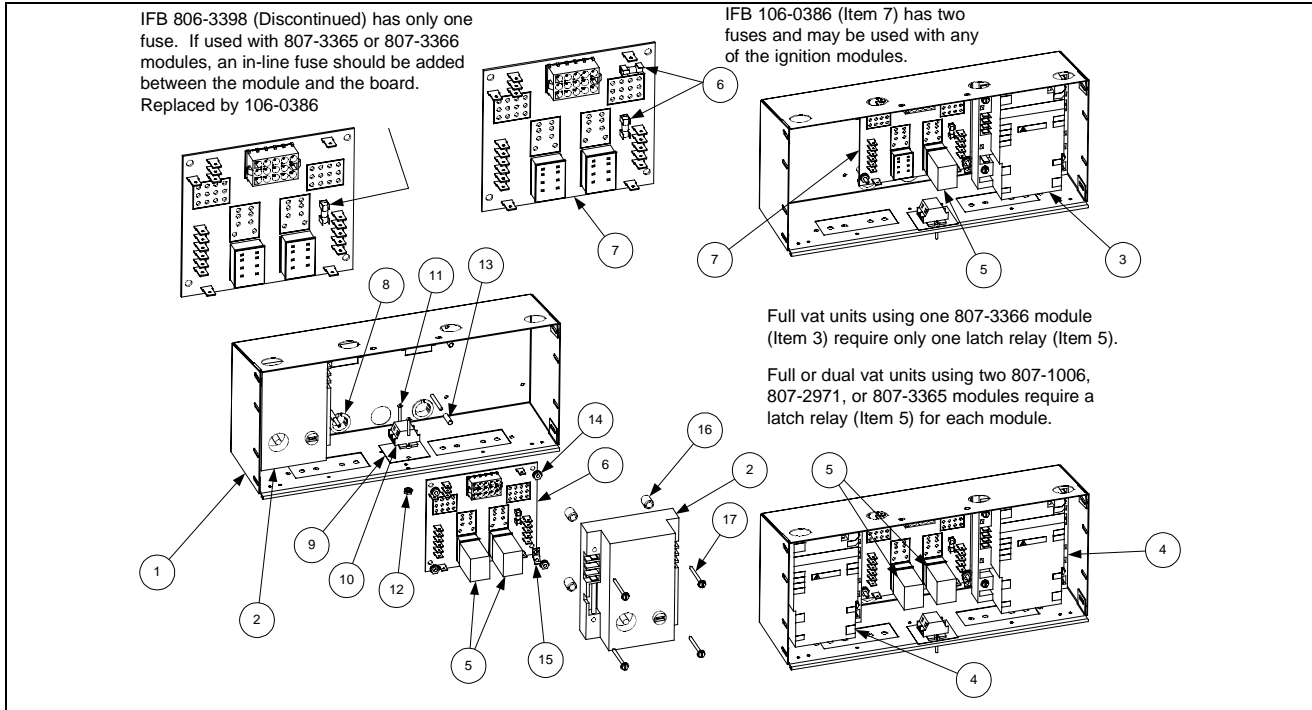

ITEM	PART #	COMPONENT
1	200-5996	Box Assembly, One-Piece Component
2	807-1006	Ignition Module, Full or Dual Vat (fuse-protected)
*	807-2971	Ignition Module, Full or Dual Vat (fuse-protected) (Australian units only)
3	807-3366	Ignition Module, Full Vat (unfused)
4	807-3365	Ignition Module, Dual Vat (unfused) <input type="checkbox"/> use 1 wire 1 connector ign. cable 826-2024
5	807-0833	Relay, 12V 5Amp Latch ( <i>use Relay Clip 810-2243 to secure relay in place</i> )
*	807-0834	Relay, 12V 5Amp Basket Lift ( <i>use Relay Clip 810-2243 to secure relay in place</i> )
6	807-3843	Fuse, 3A 250V Subminiature
7	106-0386	Interface Board (double fuse-protected)(use w/ 807-3365, 807-1006 or 807-3366)
*	806-4973	Interface Board (used with 240V manufactured gas units only)
*	806-3683	Interface Board (used with Ger. fryers with 24V blowers only) use 5A fuse 807-3293
*	106-3044	Interface Board, FAST Computer ( <i>uses 807-3969 latch relay in place of Item 5</i> )
*	806-3641	Interface Board, (used in Holland)
*	806-4195SP	Interface Board, (used with manufactured gas Hong Kong)
*	806-3535	Interface Board, (used in Churches w/ Far West Computers)
8	807-1926	Bushing, .875 Diameter Split
9	816-0217	Paper, Insulating (Items 9, 10, 11, 12 not used on Hong Kong units)
10	810-1164	Block, Terminal (See Item 9)
11	826-1359	Screw, 4-40 x 3/4-inch Slotted Round Head (See Item 9) (Pkg. of 25)
12	826-1366	Nut, 4-40 Keps Hex (See Item 9) (Pkg. of 25)
13	807-1241	Spacer, Interface Board (.151-inch ID x 5/8-inch)
14	809-0250	Nut, 6-32 Keps Hex
15	826-1337	Tab, Push-On Terminal (Pkg. of 5)
16	826-1346	Spacer, Ignition Module (.260-inch ID x 1/2-inch) (Pkg. of 10)
17	809-0441	Screw, #7 x 1 1/2-inch Slotted Washer Hex Head
*	826-1157	Fuse Kit, Ignition Module 3 Amp (fuse and fuse puller)
*	806-2071	Computer Cable 15-pin
*	806-3660	Sound Device ( <i>For units with KFC1 Computers, use Speaker 807-1617</i> )
*	807-1359	Mount, Tie-Wrap (used on CE units only)

\* Not illustrated.

## 2.8 Control Panel Assemblies, Flue Caps, Top Caps, and Related Components

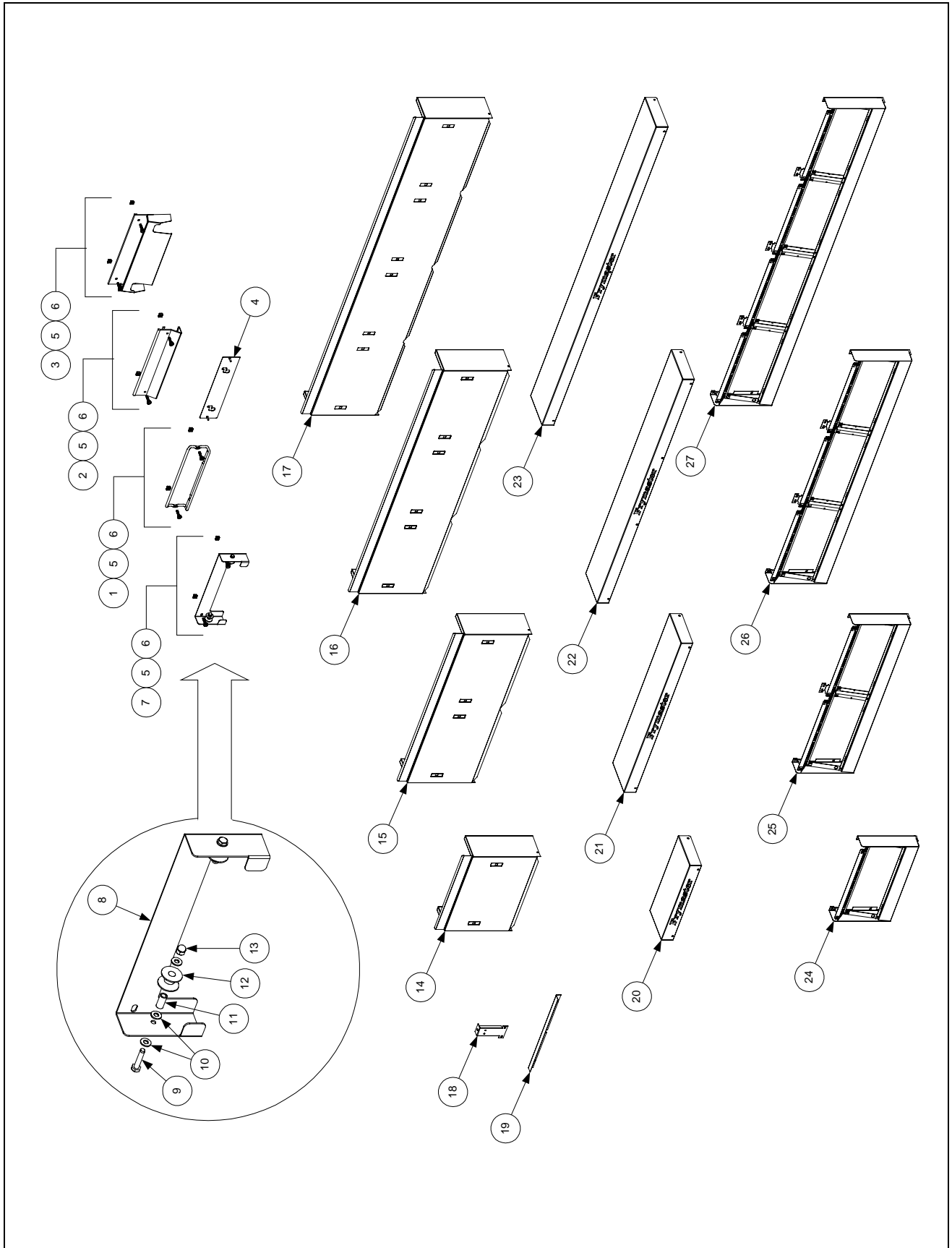

ITEM	PART #	COMPONENT
1	810-2793	Basket Hanger, Wire Form
2	803-0028	Basket Hanger, Extruded Aluminum (replaced by 810-2793)
3	823-1462	Basket Hanger, Burger King
*	106-2186	Basket Hanger Assembly, Burger King (includes Items 1, 4 and 13)
4	106-2185	Bracket, Burger King Easy-Off Basket Hanger (used w/Item 1)
5	809-0171	Thumbscrew, ¼-20 X 1⅜-inch Basket Hanger
*	809-0921	Spacer, Basket Hanger
6	826-1351	Nut, Cage (receives Basket Hanger Thumbscrew) (Pkg. of 10)
7	806-9257SP	Roller Assembly, Basket Lift (Complete)
8	910-8284	Bracket, One-Piece Roller Guide
9	826-1334	Capscrew, ¼ – 20 x 1¼” Stainless Steel Hex Head (Pkg. of 5)
10	809-0190	Washer, ¼” Stainless Steel Flat
11	810-0374	Spacer, Tubular
12	810-0194	Roller, Basket Lift Guide
13	809-0047	Nut, ¼ – 20 Cap (also used w/Item 4)
14		Flue Cap, Single Fryer, w/lip
	910-5018	Standard (use 910-5019 on Burger King fryers)
	910-6545	Optional (without lip along flue opening)
	823-3749	Burger King with Button Studs (used w/Item 4)
15		Flue Cap, 2-Fryer Battery
	823-2540	Standard (use 823-2542 on Burger King fryers)
	823-3536	Burger King with Button Studs (used w/Item 4)
16		Flue Cap, 3-Fryer Battery (use 823-2543 on Burger King fryers)
	823-2541	Standard (use 823-2543 on Burger King fryers)
	823-3537	Burger King with Button Studs (used w/Item 4)
17	823-2569	Flue Cap, 4-Fryer Battery
	823-3538	Burger King with Button Studs (used w/Item 4)
18	900-5486	Support, Flue Cap
19	900-4253	Flue Cap Retaining Strip, Burger King
*	910-3557	Flue Deflector
20		Top Cap, Single Fryer
	824-0404	Standard
	824-0408	H50 side of H50/FB18 Battery
21	824-0405	Top Cap, Two-Fryer Battery
22	824-0406	Top Cap, Three-Fryer Battery
23	824-0407	Top Cap, Four-Fryer Battery
24		Control Panel Assembly, Single Fryer
	806-4732SP	Standard (see Note 1)
	806-5363SP	H50 side of H50/FB18 Battery
25	806-4733SP	Control Panel Assembly, 2-Fryer Battery (see Note 2)
26	806-4734SP	Control Panel Assembly, 3-Fryer Battery (see Note 3)
27	806-5018SP	Control Panel Assembly, 4-Fryer Battery (see Note 4)
*	826-1379	Screw, #10 X ½-inch Philips Head (Pkg. of 10) (attaches top cap)
*	826-1371	Screw, #8 X ½-inch Hex Washer Head (Pkg. of 25) (attaches flue cap)

\* Not illustrated.

**NOTES:**

1. Use 806-9712SP on KFC fryers; use 106-2927SP for units with fallback controllers.
2. Use 806-9713SP on KFC fryers; use 106-2928SP for units with fallback controllers.
3. Use 806-9714SP on KFC fryers; use 106-2929SP for units with fallback controllers.
4. Use 806-9715SP on KFC fryers.

## 2.9 Controller Assemblies

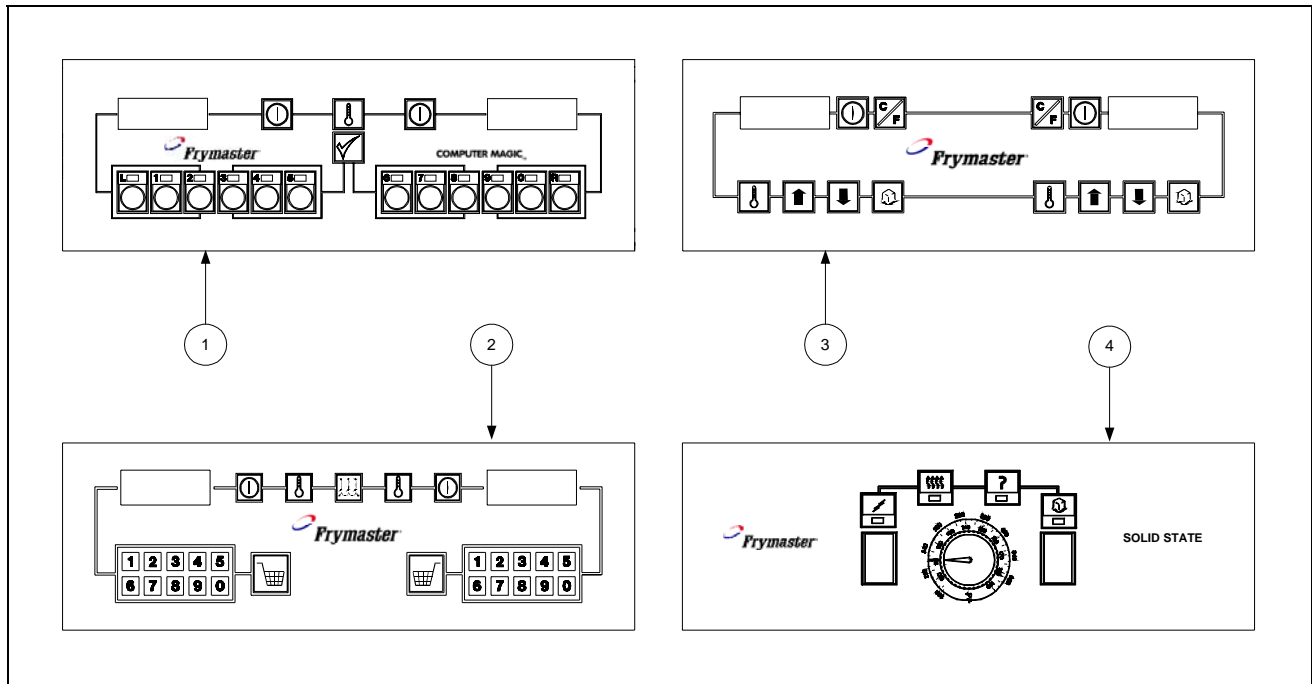

ITEM	PART #	COMPONENT
1		Computer Magic III
	106-1187SP	Dual Vat (CE)
	106-1151SP	Dual Vat (Non-CE)
	106-1155SP	Dual Vat w/ 8 sec. Melt Cycle
	106-1188SP	Full Vat (CE)
	106-1150SP	Full Vat (Non-CE)
	106-1216	Full Vat, Remote BK on the Hood
	106-1226	Full Vat, Remote BK in the Hood
2		Basket Lift Timer
	106-2081SP	Dual Vat (CE)
	106-2074SP	Dual Vat (Non-CE)
	106-2077SP	Full Vat (CE)
	106-2073SP	Full Vat (Non-CE)
	826-1552	Kit, 120v Push Button 15 min timer retrofit
	826-1667	Kit, 240v Push Button
3		Digital Controller
	106-1506SP	Dual Vat (CE)
	106-1510	Dual Vat (Non-CE)
	106-1505SP	Full Vat (CE)
	106-1509SP	Full Vat (Non-CE)
4		Solid State (Analog) Controller ( <i>Controller Knob is 810-0387</i> )
	806-3564E	Dual Vat (CE) w/ 8 sec. Melt Cycle
	806-3008E	Dual Vat (Non-CE)
	806-3563E	Full Vat (CE) w/ 8 sec. Melt Cycle
	806-3006E	Full Vat (Non-CE) ( <i>for Foodmaker units, use 806-7385</i> )807-2236 Overlay
*	106-0613	CM4-S Computer (CE)
*	806-4323	Fallback Controller Assembly

Continued on the following page

## 2.9 Controller Assemblies cont.

ITEM	PART#	COMPONENT
*	806-5300	KFC1 Computer ( <i>requires special control panel assembly – see Page 2-22</i> )
*	826-1032SP	Kit, Bezel Screw and Tinnerman Clip (contains two screws and two clips)
*	826-1379	Screw, #10 X ½-inch Philips Truss Head (computer screws) (Pkg. of 10)
*	910-3690	Blank Panel ( <i>for fryers with remote mounted computers</i> )
*	806-2071	Harness, Main Short Wire 14 ½" 15-pin Computer to Interface Board
*	806-3528	Harness, Main 7 ½' BK 15-pin Computer to Interface Board
*	806-3388	Harness, Main 20' Remote N Pot 15-pin Computer to Interface Board

\* Not illustrated.

## 2.10 Door Assemblies

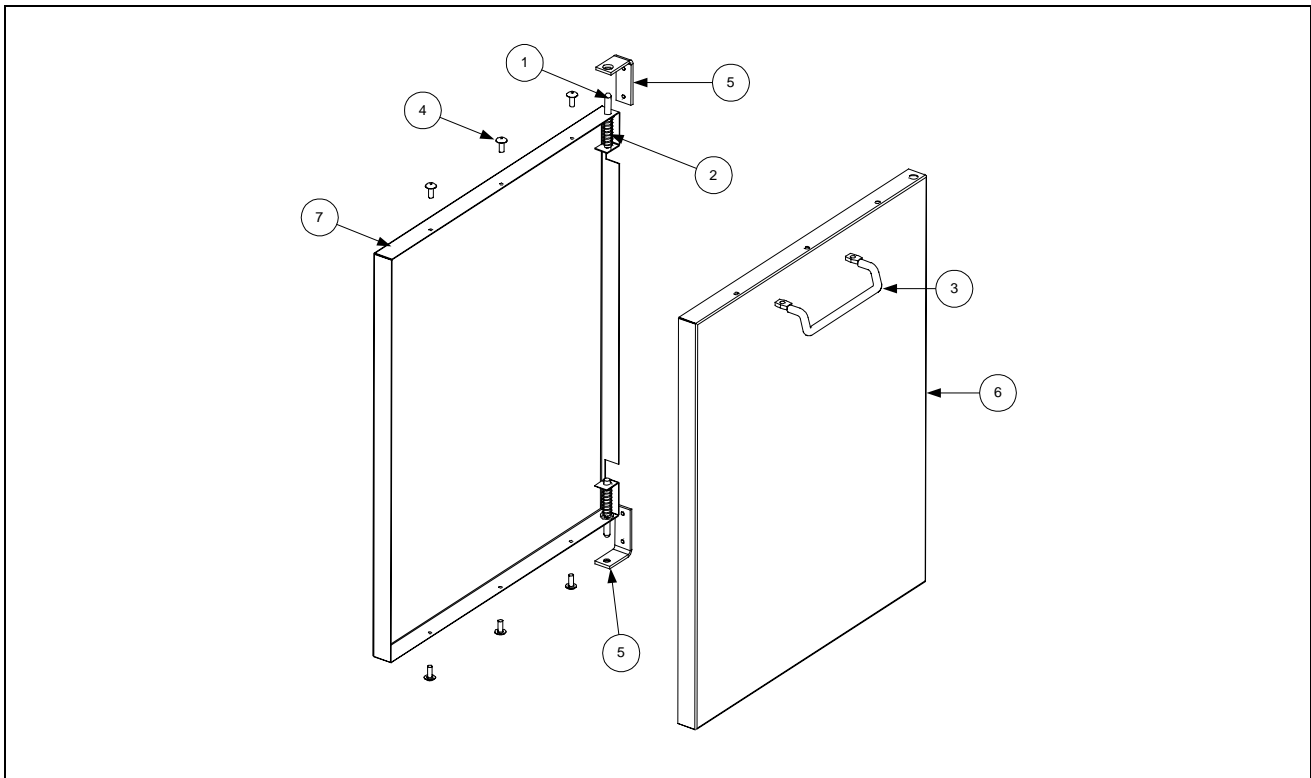

ITEM	PART #	COMPONENT
	806-1962SP	<b>Door Assembly, Complete (for use on MJH50 and FMH50 units)</b>
	806-6405SP	<b>Door Assembly, Complete (for use on FPH50 units)</b>
1	806-4487SP	Door Pin Assembly
2	826-1343	Spring, Door Pin (Pkg. of 10)
3	810-1422	Handle, Door, Wireform, Stainless Steel ( <i>must be ordered separately</i> )
4	826-1379	Screw, #10 x ½" Phillips Head, Zinc Plated (Pkg. of 10)
5	810-1508	Hinge, Door, Universal ( <i>must be ordered separately</i> )
6	824-0616	Panel, Door, Outer
7		Liner, Door
	900-6595	Used with 806-1962SP
	900-4807	Used with 806-6405SP
*		Magnet, Door
	810-0066	Used with 806-1962SP on Door
	810-1105	Used with 806-6405SP on Frame

\* Not illustrated.

## 2.11 Drain System Components

### 2.11.1 Filter Magic II Square Drain Components, Standard Configuration (Units Built Before 03/01/01)

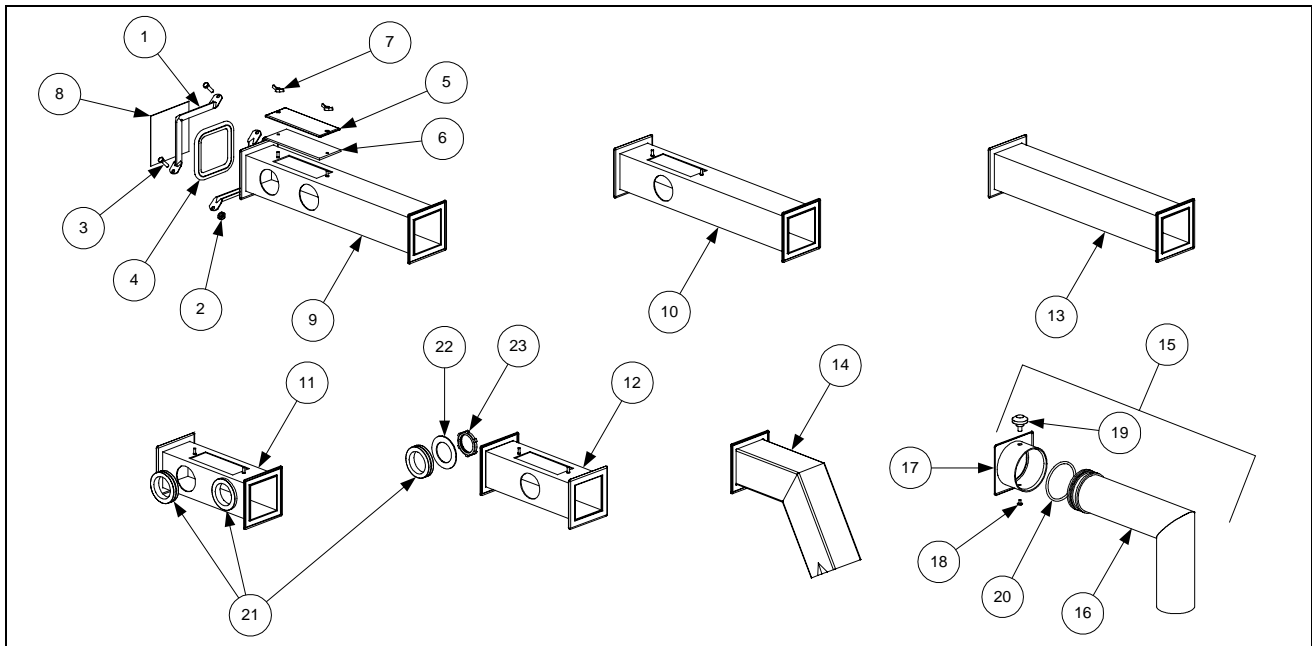

ITEM	PART #	COMPONENT
1	810-0396	Clamp Section (requires 2 per connection)
2	826-1362	Nut, ¼-20 (Pkg. of 10)
3	826-1375	Screw, 10-32 x ¾ (Pkg. of 5)
4	816-0032	Seal (Connection Gasket)
*	826-0877	Kit, Clamp Assembly (2 each of Items 1, 2, and 3, and 1 of Item 4)
5	826-1348	Cover, Cleanout (Pkg. of 5)
6	816-0021	Gasket, Cleanout
7	826-1382	Wing Nut, Cleanout Cover Retaining (Pkg. of 10)
8	900-0757	Cover, Drain End
9	823-0724	Drain Tube, Dual Vat, 15.5" Long
10	823-0717	Drain Tube, Full Vat, 15.5" Long
11	823-0725	Drain Tube, Closed End, Dual Vat, 8.12" Long
12	823-0718	Drain Tube, Closed End, Full Vat, 8.12" Long
13	823-0731	Drain Tube Extension, Spreader Cabinet, 15.5" Long
14	823-0719	Drain Outlet, Fixed
15	806-4068SP	Drain Outlet Assembly, Swivel (contains 1 each of Items 16-20)
16	823-1091	Drain Tube, Swivel
17	823-1092	Collar, Drain
18	809-0115	Screw, 10-32
19	810-0388	Knob, Clamping
20	816-0083	O-Ring, 2.5" ID
21	816-0092	Grommet, 1-inch Drain Tube
22	826-1345	Washer, Drain Tube Retaining (Pkg. of 25)
23	809-0347	Nut, Drain Tube Retaining

\* Not illustrated.



**2.11.2 Filter Magic II Square Drain Components, Non-Standard Configurations (Units Built after 03/01/01)**

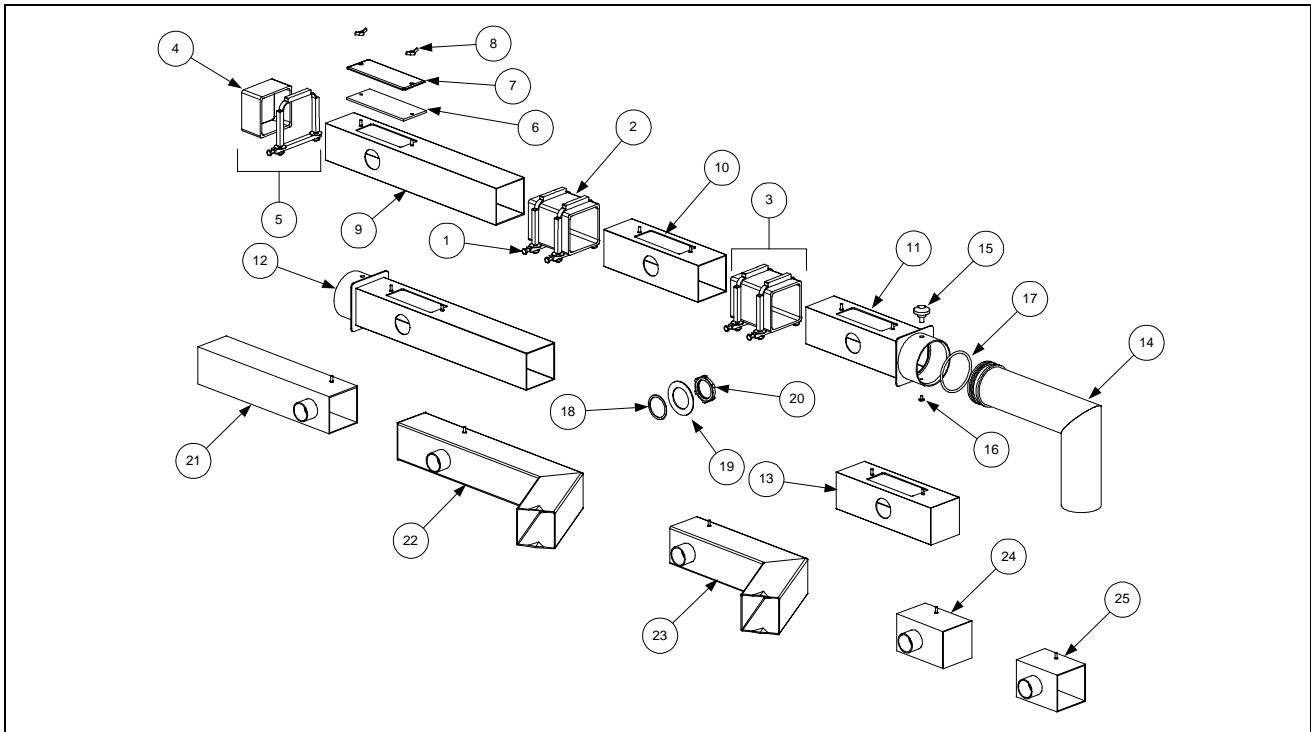

ITEM	PART #	COMPONENT
1	806-6374	Clamp Assembly
2	816-0420	Boot (Connection Seal)
3	KIT-0257SP	Clamp Assembly and Boot Kit (contains 2 of Item 1 and 1 of Item 2)
4	816-0123	Cap, Square Drain End
5	KIT-0256SP	Kit, Square Drain End Cap (contains 1 each of Items 1 and 4)
6	816-0021	Gasket, Cleanout
7	826-1348	Cover, Cleanout (Pkg. of 5)
8	826-1382	Wing Nut, Cleanout Cover Retaining (Pkg. of 10)
9	823-1701	Drain Tube, 15" Long, Open Both Ends
10	823-2128	Drain Tube, 8.3" Long, Open at Both Ends
11	823-1697	Swivel Drain Receiver, Filter Left of Fryer
12	823-1698	Swivel Drain Receiver, Filter Right of Fryer
13	823-1702	Drain Tube, 8.3" Long, Left End Closed
14	823-1091	Drain Outlet, Swivel
15	810-0388	Knob, Clamping
16	809-0115	Screw, 10-32
17	816-0083	O-Ring, 2.5" ID
18	816-0124	Washer, Fiber
19	826-1345	Washer, Drain Tube Retaining (Pkg. of 25)
20	809-0347	Nut, Drain Tube Retaining
21	823-2225	Drain Section, Dual Vat, 11.55" Long
22	823-3755	Drain Elbow, Full Vat Left or Right, 13.8" Long
23	823-3052	Drain Elbow, Dual Vat Left or Right, 9.7" Long
24	823-2221	Drain End, Dual Vat Left or Right
25	823-2212	Drain Section, Dual Vat Left or Right

### 2.11.3 FootPrint III Square Drain Components, Standard Configuration

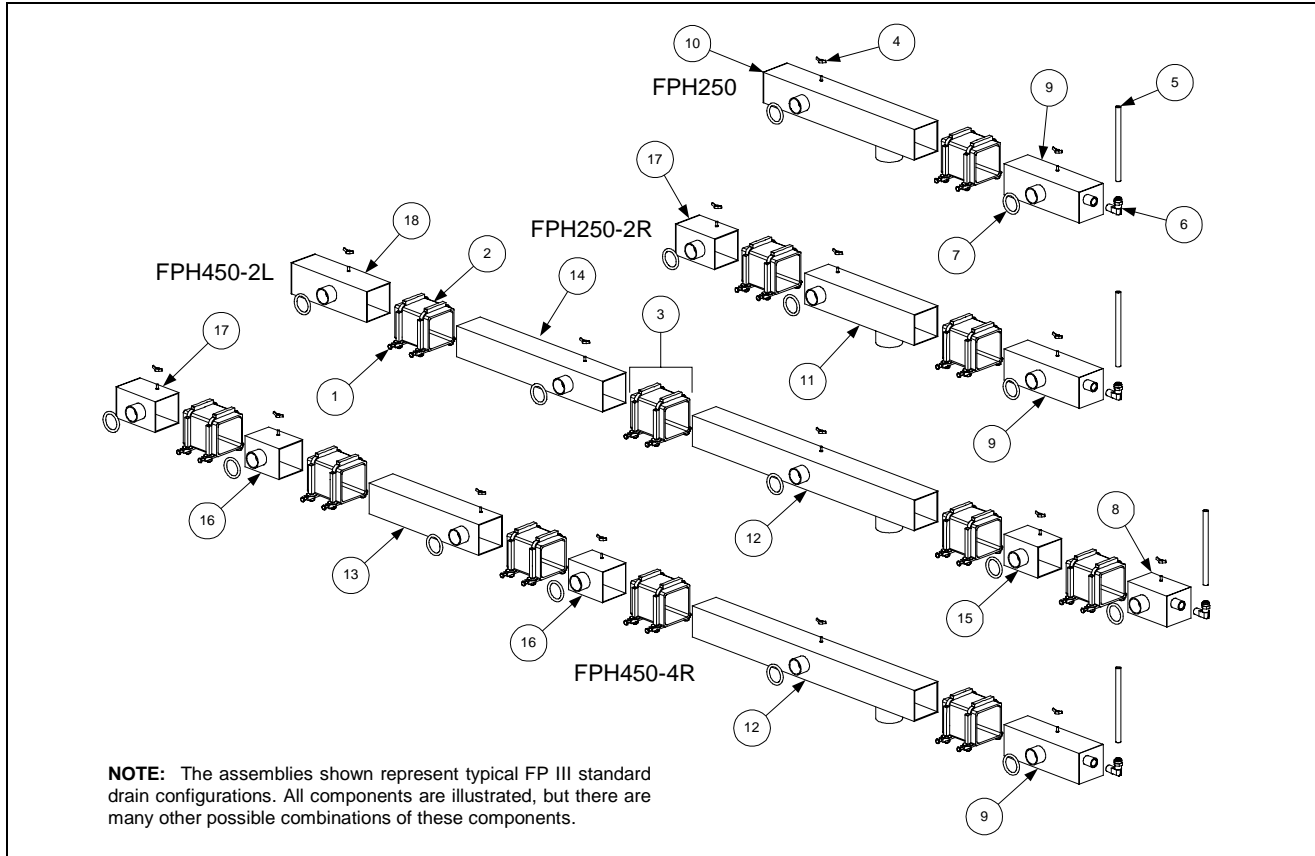

ITEM	PART #	COMPONENT
1	806-6374	Clamp Assembly
2	816-0420	Boot (Connection Seal) 3 1/2"
3	KIT-0257SP	Clamp Assembly and Boot Kit (contains 2 of Item 1 and 1 of Item 2)
4	826-1382	Wing Nut (Pkg. of 10)
5	811-0932	Vent Tube, Teflon, 3/8" OD (FP III units manufactured after Sep 97) per foot
6	810-1372	Fitting, 90°, Vent Tube (for use with Item 5)
7	816-0135	O-Ring
8	823-2444	Left End Section, Dual Vat, 4.06" Long
9	823-2445	Left End Section, Full Vat, 7.95" Long
10	823-2231	Drain Outlet Section, Closed, 15.86" Long
11	823-2294	Drain Outlet Section, Open, Dual Vat, 11.55" Long
12	823-2223	Drain Outlet Section, Open, Full Vat, 23.38" Long
13	823-2225	Drain Section, Dual Vat, 11.55" Long
14	823-2301	Drain Section, Full Vat, 15.39" Long (Hole on Rt. 823-2316)
15	823-2193	Drain Section, Left End, Dual Vat, 3.57" Long (stud left of center)
16	823-2212	Drain Section, Right End, Dual Vat, 3.57" Long (stud right of center)
17	823-2221	Right End Section, Dual Vat, 4.06" Long
18	823-2198	Right End Section, Full Vat, 7.89" Long
*	806-8408SP	Drain Assembly FPH350 w/out Rear Flush
*	806-8414SP	Drain Assembly FPH 450 w/out Rear Flush

## 2.11.4 FootPrint III Square Drain Components, Rear Flush Configuration

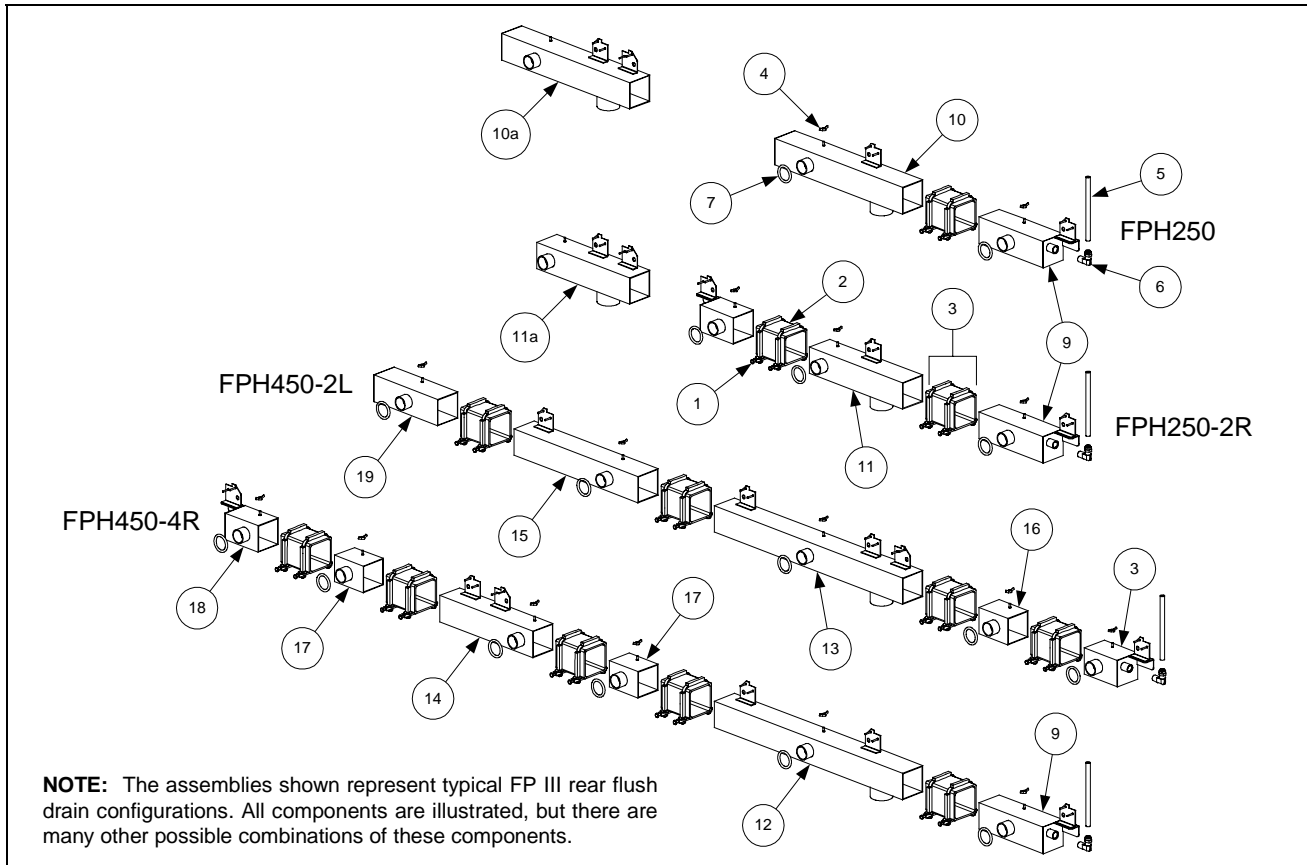

ITEM	PART #	COMPONENT
1	806-6374SP	Clamp Assembly
2	816-0420	Boot (Connection Seal)
3	KIT-0257SP	Clamp Assembly and Seal Kit
4	826-1382	Wing Nut (Pkg. of 10)
5	811-0932	Vent Tube, Teflon, 3/8" OD (FP III units manufactured after Sep 97) per foot
6	810-1372	Fitting, 90°, Vent Tube (for use with Item 5)
7	816-0135	O-Ring (Valve)
8	823-2199	Left End Section, Dual Vat, 4.06" Long
9	823-2197	Left End Section, Full Vat, 7.95" Long
10	823-2211	Drain Outlet Section, Closed, Full Vat, 18.60" Long (one bracket)
10a	823-2210	Drain Outlet Section, Closed, Dual Vat, 15.86" Long (two brackets)
11	823-2204	Drain Outlet Section, Open, Dual Vat, 11.55" Long (one bracket)
11a	823-2192	Drain Outlet Section, Open, Dual Vat, 11.55" Long (two brackets)
12	823-2200	Drain Outlet Section, Open, Full Vat, 23.38" Long (two brackets)
13	823-2207	Drain Outlet Section, Open, Full Vat, 23.38" Long (three brackets)
14	823-2202	Drain Section, Dual Vat, 11.55" Long (two brackets)
15	823-2233	Drain Section, Full Vat, 15.39" Long (one bracket)
16	823-2193	Drain Section, Left End, Dual Vat, 3.57" Long (stud left of center)
17	823-2212	Drain Section, Right End, Dual Vat, 3.57" Long (stud right of center)
18	823-2194	Right End Section, Dual Vat, 4.06" Long
19	823-2198	Right End Section, Full Vat, 7.89" Long

### 2.11.5 FootPrint III Square Drain Components, Foodmaker Configuration

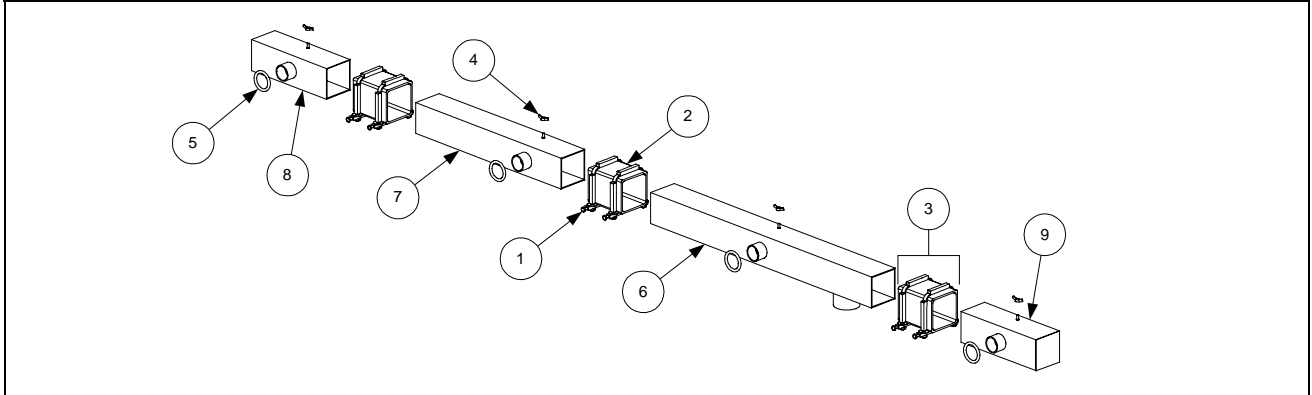

ITEM	PART #	COMPONENT
1	806-6374	Clamp Assembly
2	816-0420	Boot (Connection Seal)
3	KIT-0257SP	Clamp Assembly and Seal Kit
4	826-1382	Wing Nut (Pkg. of 10)
5	816-0135	O-Ring
6	823-2223	Drain Outlet Section, Open 23.38" Long
7	823-2301	Drain Section, 15.39" Long
8	823-2198	Right End Section, 7.95" Long
9	823-2222	Left End Section, 7.95" Long

## 2.12 Drain Valves, Drain Valve Assemblies and Associated Parts

### 2.12.1 Drain Valves and Drain Extensions

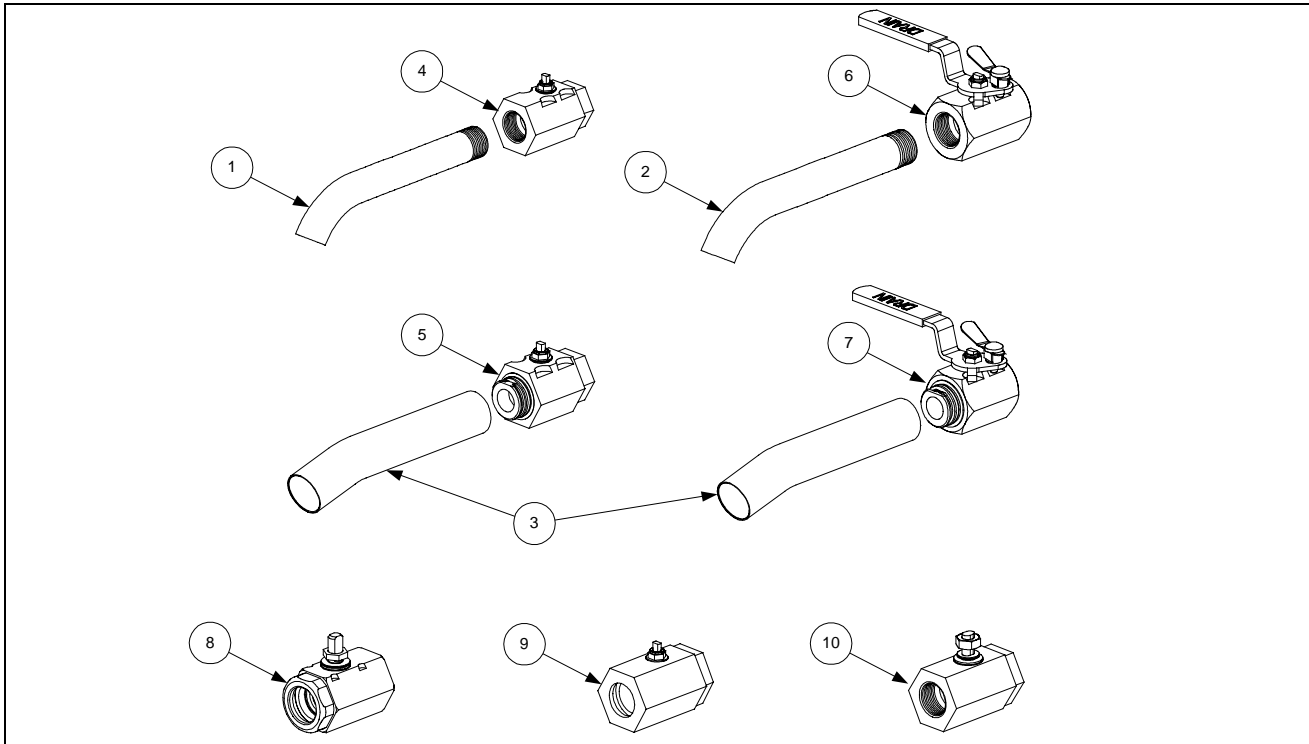

ITEM	PART #	COMPONENT
1	812-1227	Drain Valve Extension, Screw-In DV (1-inch NPT)
2	812-1226SP	Drain Valve Extension, Screw-In FV (1 1/4-inch NPT)
3	210-4175	Drain Valve Extension, Bayonet Connection (used only with Items 5 and 7)
4	810-1338	Drain Valve, 1-inch NPT Inlet and Outlet, Dual Vat
5	810-2536	Drain Valve, 1-inch NPT Inlet, Bayonet Outlet, Non-Filter Dual Vat
6	810-1569	Drain Valve w/Handle, 1/4-inch NPT Inlet and Outlet, Full Vat
	806-4145	Drain Valve, 1/4-inch- CF or High Sediment (Large Bore)
7	810-2535	Drain Valve w/Handle, 1/4-inch NPT Inlet, Bayonet Outlet Non-Filter FV*
8	810-1018	Drain Valve, 1/4-inch NPT Inlet, 1-inch O-Ring Outlet, 1/2-inch Stem, FV*
9	810-1114	Drain Valve, 1/4-inch NPT Inlet, 1-inch O-Ring Outlet, 3/8-inch Stem, DV*
10	810-1020	Drain Valve, 1/4-inch NPT Inlet, 1-inch NPT Outlet, Full Vat (Filter Magic Unit)

\* Full Vat and Dual Vat

**Application Notes:** Item 4 is used on non-filter, Filter Magic, and FootPrint III units. Items 5, 6, and 7 are used only on non-filter units. Items 8 and 9 are used only on FootPrint III units. Item 10 is used on Filter Magic units.

## 2.12.2 MJH50 Drain Valve Assemblies

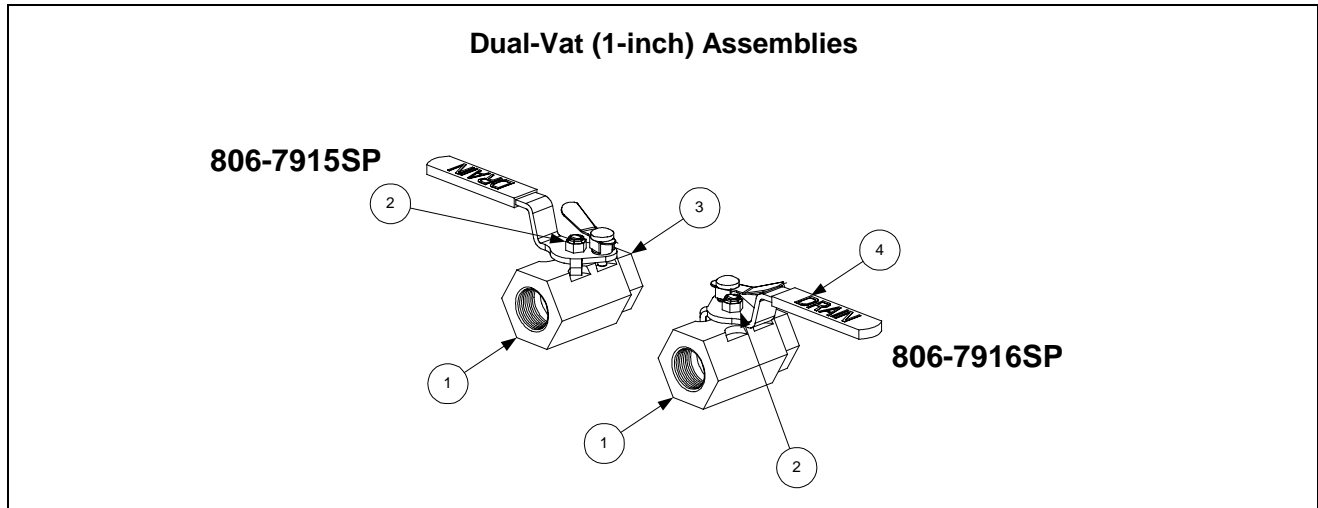

ITEM	PART #	COMPONENT
	806-7915SP	<b>Complete Assembly, Left</b>
	806-7916SP	<b>Complete Assembly, Right</b>
		<b>Components</b>
1	810-1338	Drain Valve, 1-inch NPT Inlet and Outlet ( <i>See NOTE</i> )
2	809-0539	Nut, 2-way Lock, $\frac{3}{8}$ -16
3	810-1568	Handle, Drain Valve, w/Lock Pin, Left
4	810-1567	Handle, Drain Valve, w/Lock Pin, Right

**NOTE:** For a short period in early 2003, some versions of these assemblies were manufactured with valves having a snap-on connection at the outlet end (see Item 5 on Page 2-30). If replacing the valve in this type assembly, use 810-2536 instead of 810-1338.

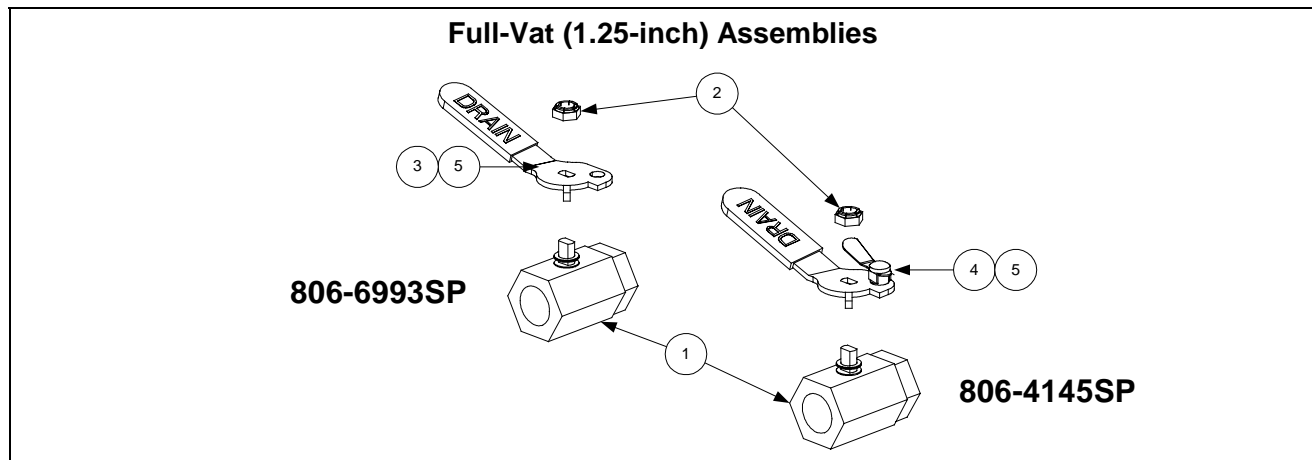

ITEM	PART #	COMPONENT
	806-6993SP	<b>Complete Assembly, Domestic Units</b>
	806-4145	<b>Complete Assembly, Export Units (Including CE)</b>
		<b>Components</b>
1	810-1017	Drain Valve, 1¼-inch Gemini – non-filter
2	809-0589	Nut, ½-inch Lock
3	810-0820	Handle, Drain Valve w/o Lock Pin (used on domestic units)
4	810-1427	Handle, Drain Valve w/Lock Pin (used on export units)
5	816-0211	Sleeve, Valve Handle

### 2.12.3 FMH50 Dual Vat (1-Inch) Valve Assemblies

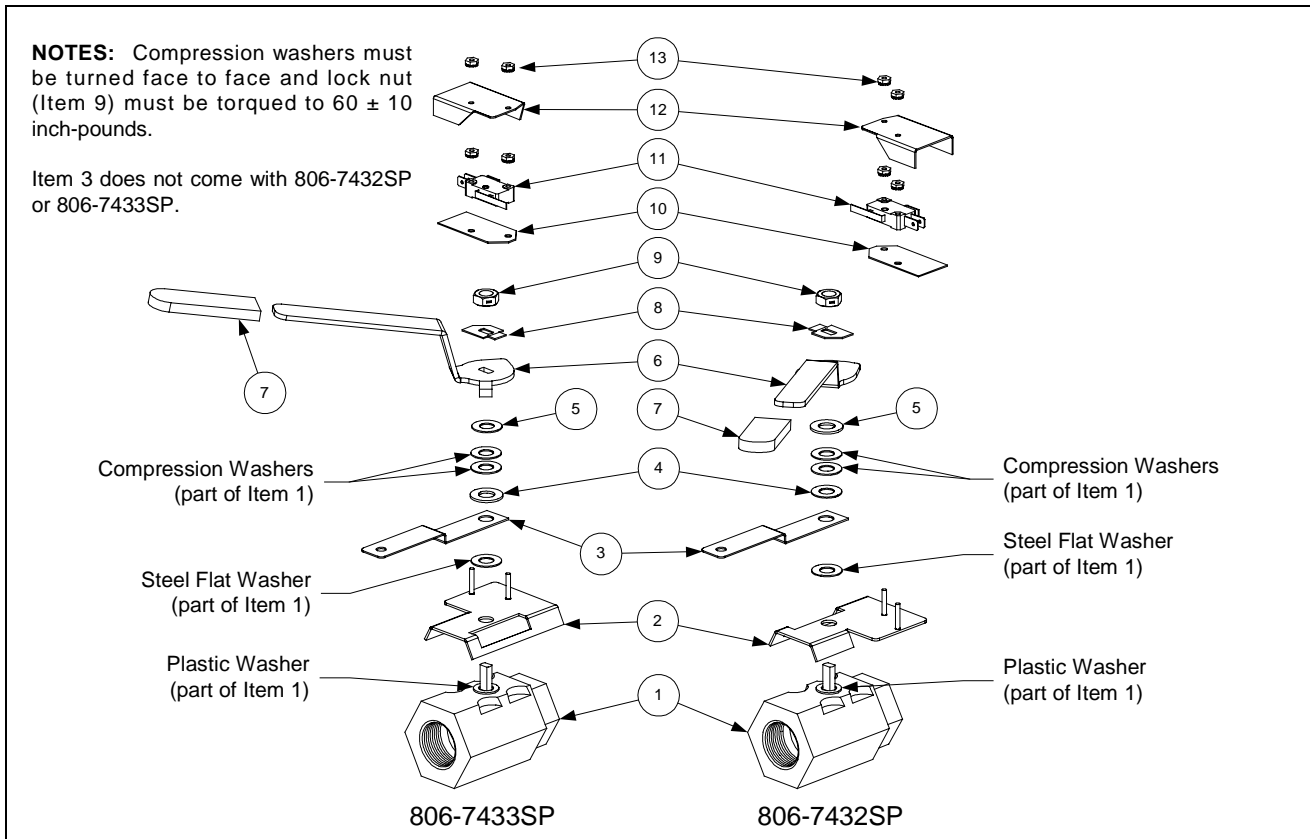

ITEM	PART #	COMPONENT
	806-7433SP	<b>Complete Assembly, Left</b> (does not include Items 3 and 8)
	806-7432SP	<b>Complete Assembly, Right</b> (does not include Items 3 and 8)
		<b>Components</b>
1	810-1338	Drain Valve, 1-inch NPT Inlet and Outlet, Dual Vat
2		Bracket, Drain Valve Microswitch
	106-2671	Left (used in 806-7433SP)
	106-2672	Right (used in 806-7432SP)
3	900-2355	Bracket, DV Drain Valve
4	809-0196	Washer, $\frac{3}{8}$ -inch Flat
5	810-1165	Washer, DV Drain Valve Teflon
6		Handle, DV Drain Valve
	201-3916	Left (used in 806-7433SP)
	202-3916	Right (used in 806-7432SP)
7	814-0047	Sleeve, Red Valve Handle
8	900-2934	Retainer, $\frac{3}{8}$ -inch Nut
9	809-0539	Nut, 2-way Lock, $\frac{3}{8}$ -16
10	816-0220	Insulation, RF Switch
11	807-2103	Microswitch, Lever Activated
12		Cover, Drain Safety Switch
	901-2348	Left (used in 806-7433SP)
	902-2348	Right (used in 806-7432SP)
13	826-1366	Nut, Keps, 4-40, w/external teeth (Pkg. of 25)

## 2.12.4 FMH50 Full Vat (1¼-inch) Valve Assembly

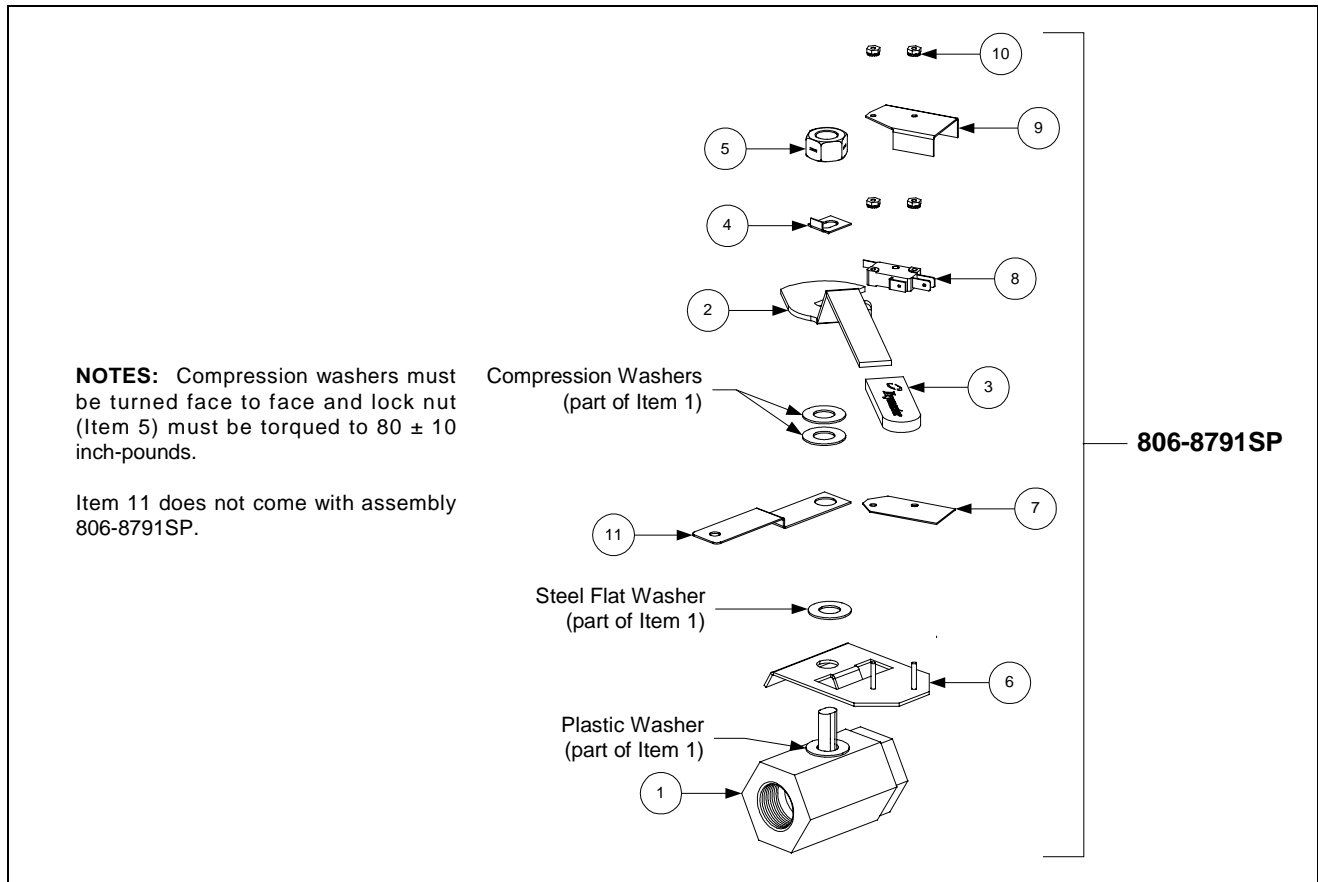

ITEM	PART #	COMPONENT
	806-8791SP	<b>Complete Assembly</b> (does not include Item 11)
1	810-1020	Drain Valve, 1¼-inch NPT Inlet, 1-inch NPT Outlet
	810-1018	Drain Valve, 1 ¼-inch, for Hybrid Units, Single FP and Jack in the Box FM.
2	900-2521	Handle, Drain Valve
3	814-0047	Sleeve, Red Valve Handle
4	900-2936	Retainer, ½-inch Nut
5	809-0540	Nut, 2-way Lock, ½–13
6	806-8137	Bracket, Drain Valve Microswitch
7	816-0220	Insulation, RF Switch
8	807-2103	Microswitch, Lever Activated
9	900-2841	Cover, Drain Safety Switch
10	826-1366	Nut, Keps, 4–40, w/external teeth (Pkg. of 25)
11	900-2354	Bracket, Full Vat Drain Valve



## 2.12.5 FPH50 Dual Vat (1-Inch X 1¼-inch) Valve Assemblies

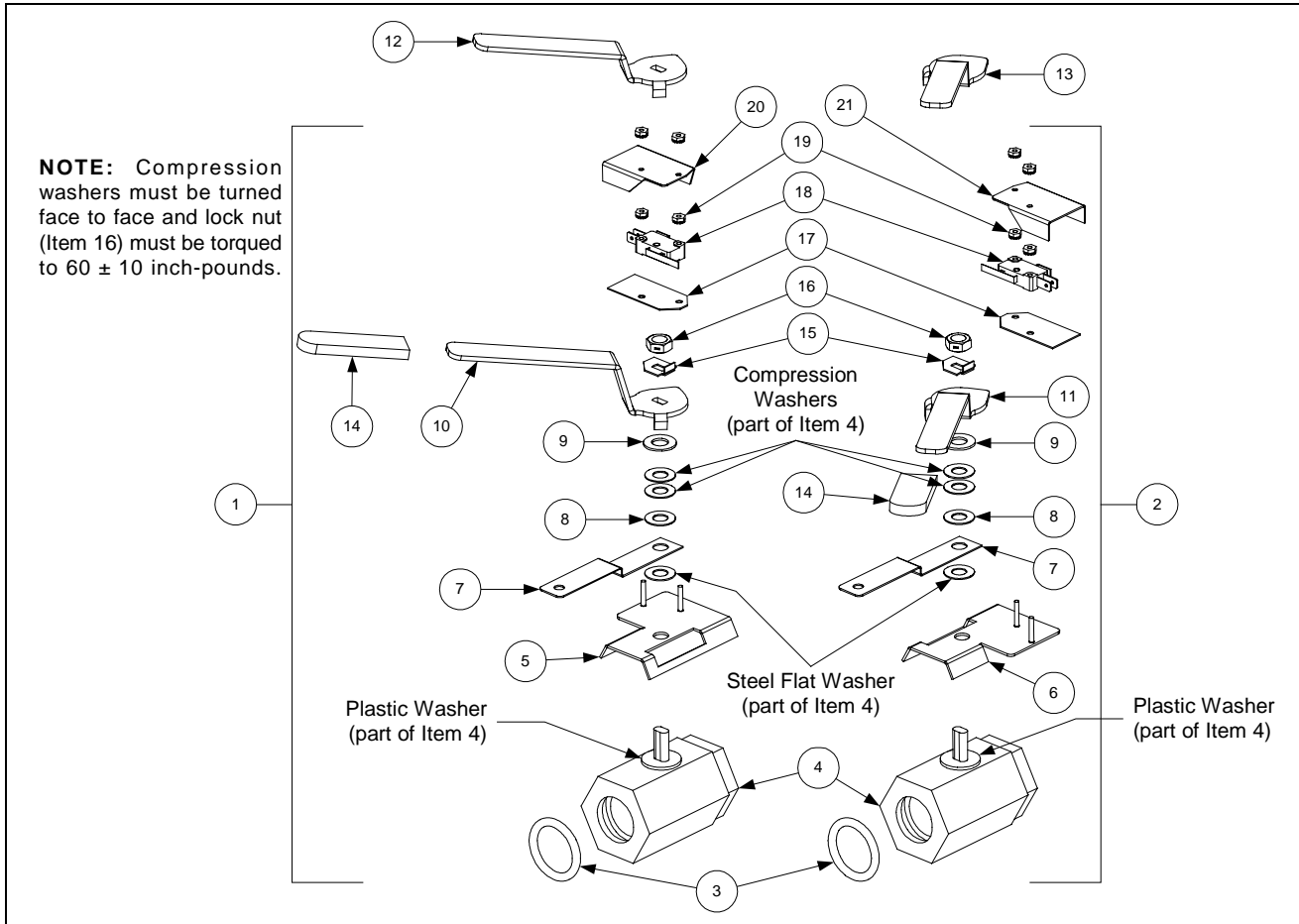

ITEM	PART #	COMPONENT
1	806-6400SP	<b>Complete Assembly, Left (for CE, use 806-6609SP)</b>
2	806-6401SP	<b>Complete Assembly, Right (for CE, use 806-6608SP)</b>
3	816-0135	O-Ring, Drain Valve, 1"
4	810-1114	Drain Valve, 1¼-inch NPT Inlet, 1-inch O-Ring Outlet, ⅜-inch Stem
5	106-2671	Bracket, Drain Valve, Microswitch, Left
6	106-2672	Bracket, Drain Valve, Microswitch, Right
7	900-2355	Bracket, Drain Valve, 1-inch
8	810-1165	Washer, Teflon
10	201-3916	Handle, Drain Valve, Left
11	200-4304	Handle, Drain Valve, Right
12	201-3985	Handle, Drain Valve, Left (replaces Item 10 in 806-6609SP)
13	200-4305	Handle, Drain Valve, Right (replaces Item 11 in 806-6608SP)
14	814-0047	Sleeve, Red Valve Handle
15	900-2934	Retainer, ⅜-inch Nut
16	809-0539	Nut, 2-way Lock, ⅜ –16
17	816-0220	Insulation, RF Switch
18	807-2103	Microswitch, Lever Activated
19	826-1366	Nut, Keps, 4–40, w/external teeth (Pkg. of 25)
20	901-2348	Cover, Drain Safety Switch Left
21	902-2348	Cover, Drain Safety Switch Right

## 2.12.6 FPH50 Full Vat (1¼-inch) Valve Assemblies

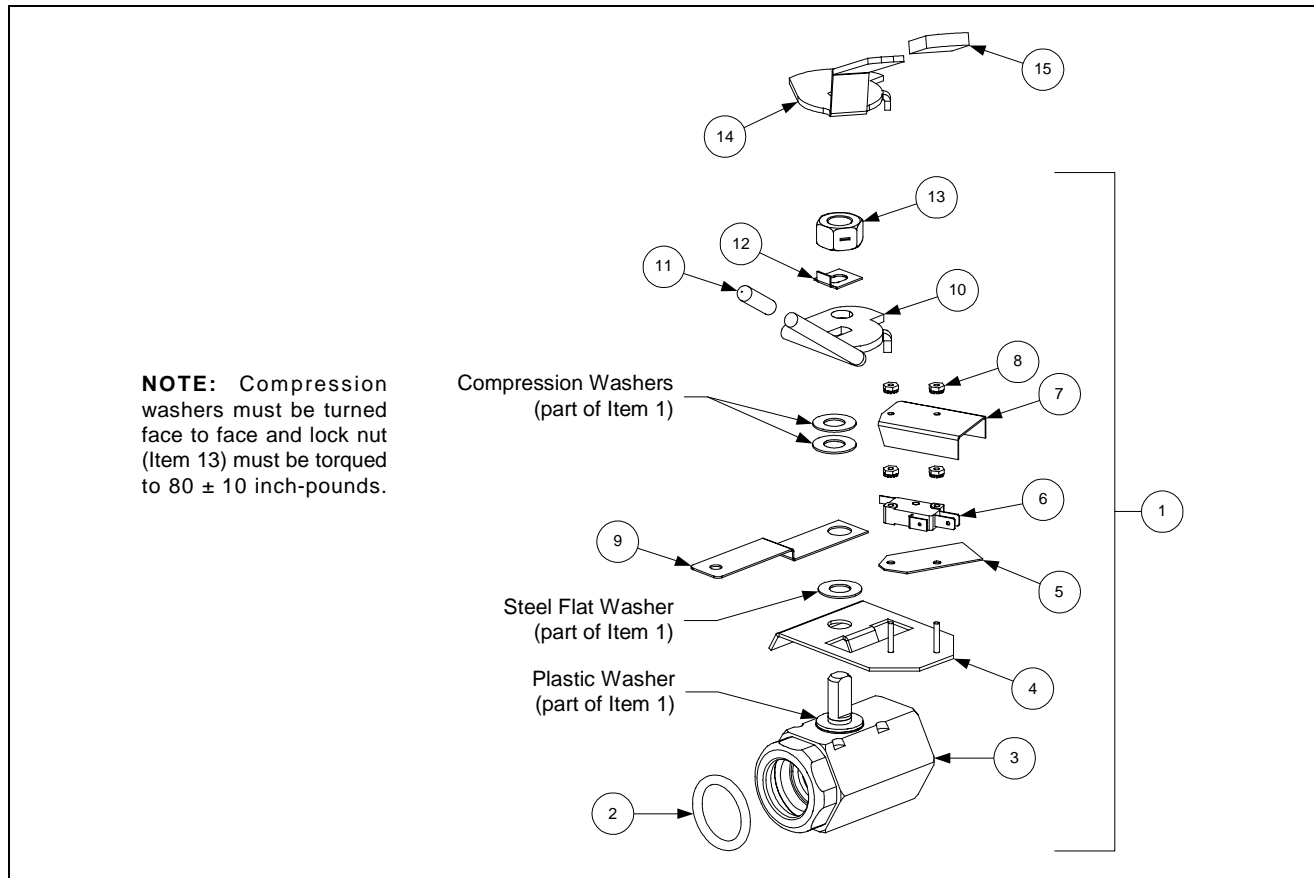

ITEM	PART #	COMPONENT
1	806-6373SP	<b>Complete Assembly (for CE, use 806-6610SP)</b>
	806-6054	Valve Assembly, 1 ¼-inch Left <b>Single FP</b>
2	816-0135	O-Ring, Drain Valve, 1¼-inch I.D.
3	810-1018	Drain Valve, 1¼-inch NPT Inlet, 1-inch O-Ring Outlet, ½-inch Stem, FV
	810-1020	Drain Valve, 1 ¼-inch NPT Inlet, 1-inch O-Ring Outlet, <b>Single FP</b>
4	806-8137	Bracket, Drain Valve, Microswitch
5	816-0220	Insulation, RF Switch
6	807-2103	Microswitch
7		Cover, Drain Safety Switch
	900-2841	Used w/806-6373SP (Item 1)
	901-2348	Replaces 900-2841 in 806-6610SP)
8	826-1366	Nut, Keps, 4–40, w/external teeth (Pkg. of 25)
9	900-2354	Bracket, Drain Valve, 1¼-inch
10	823-2371	Handle, Drain Valve (used w/806-6373SP) (replaced with 900-2609)
	823-2066	Handle, Drain Valve <b>Single FP</b>
11	810-0677	Grip, Plastic Handle
12	900-2936	Retainer, FV Drain Valve Nut
13	809-0540	Nut, 2-way Lock, ½–13 (replaces nut that comes with 810-1018)
14	900-2609	Handle, Drain Valve (replaces Item 10 in 806-6610SP)
15	814-0047	Sleeve, Red Valve Handle

## 2.13 Filtration Systems and Component Parts (Other than Drain Components)

### 2.13.1 Filter Magic II/Single FootPrint III Filter Pan Assembly

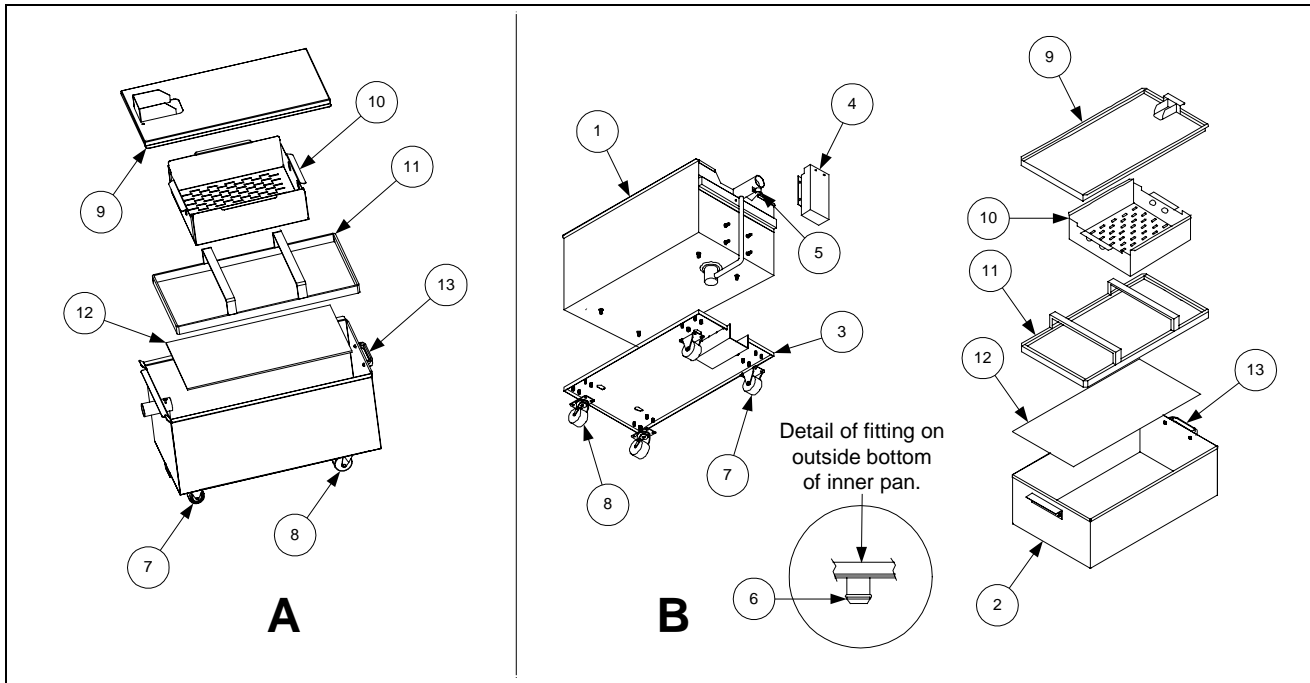

ITEM	PART #	COMPONENT
A	806-9255SP	<b>One-Piece Filter Pan Assembly</b> (Items 7, 8, 11, 12, and 13) used also on Single FP
	106-0089SP	<b>One-Piece Filter Pan Assembly with Magnasol Leaf</b> (Carl's Jr.)
	823-2751SP	One-Piece Pan Only
B	806-6093SP	<b>Two-Piece Pan Assembly, Complete</b> (Unique components are listed below.)
1	823-1360SP	Outer Pan Assembly
2	823-1731SP	Inner Pan Assembly
3	823-1361	Base, Filter Pan Assembly
4	824-0291	Cover, Suction Tube
5	910-1350	Clamp, Suction Tube
6	816-0117	O-Ring, .609 OD
*	806-4373	Heater Strip Assembly
*	811-0861	Insulation, Foam #9812
*	811-0746	Tape, Aluminum (50-yard (46m) roll)
		<b>Components Used on Both Designs</b>
7	810-2807	Caster, Rigid 2-inch
8	810-2805	Caster, Swivel 2-inch Filter Pan
9	823-1930	Cover, Drain Pan
	806-9079SP	Cover, Drain Pan Assy. W/ Handle
10	824-0416	Crumb Screen
11	810-1406	Hold Down Ring Assembly
12	900-8827	SanaGrid Filter Screen
13	810-0180	Handle, Filter Pan
*	803-0170	Paper, Filter (100 sheets) 16 1/2" x 25 3/4"
*	803-0002	Powder, Filter (80- individual packs)

\* Not illustrated

## 2.13.2 FootPrint III Filter Pan Assembly

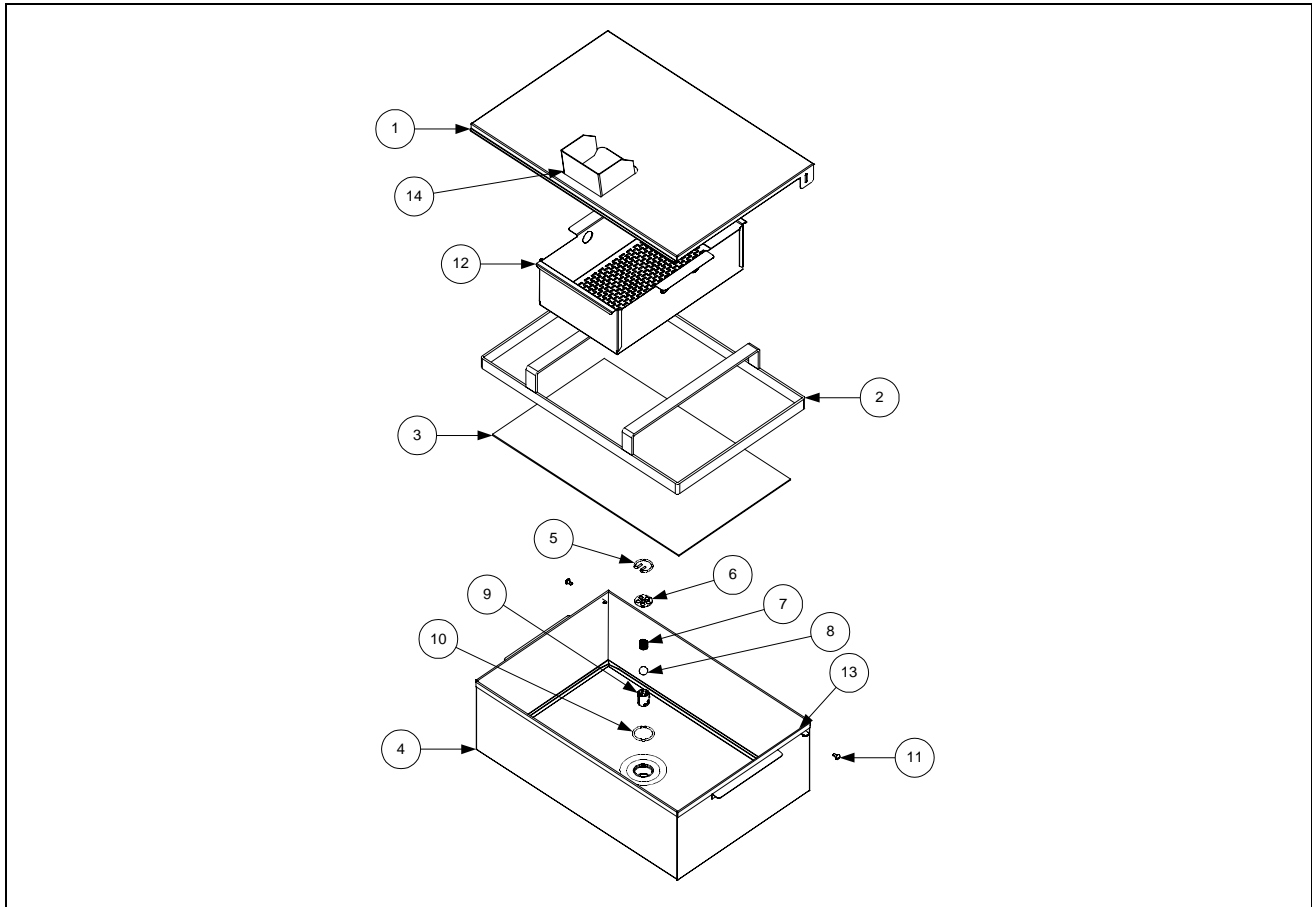

ITEM	PART #	COMPONENT
	806-5618SP	<b>Pan Assembly, Complete</b> (Items 1 through 11)
1	823-2027	Cover
2	810-1408	Hold Down Ring 13 ¾" x 20 ⅝"
3	900-8827	SanaGrid Filter Screen 12" x 19 ½" / 30.5cm x 49.5cm (without holes)
	806-8551SP	Inner Pan Assembly w/ check valve
4	823-1979SP	Pan
	826-1490	Kit, Filter Pan Check Valve Service (consists of Items 5 through 10)
5	810-1387	Retainer, Check Valve
6	900-5448	Strain Plate, Check Valve
7	810-0946	Spring, Check Valve
8	810-0948	Ball, Check Valve
9	810-1388	Tube, Check Valve
10	816-0597	O-Ring, Check Valve
11	809-0422	Screw, Shoulder
12	824-0430	Crumb Screen
13	809-0028	Nut, 10-32
14	910-4816	Splashguard, Filter Lid
*	826-1486	Kit, Swivel for FPIII Service
*	803-0170	Paper, Filter (100 sheets) 16 ½" x 25 ¾"
*	803-0002	Powder, Filter (80 individual packs)

\* Not illustrated

### 2.13.3 FootPrint III Filter Base Assemblies

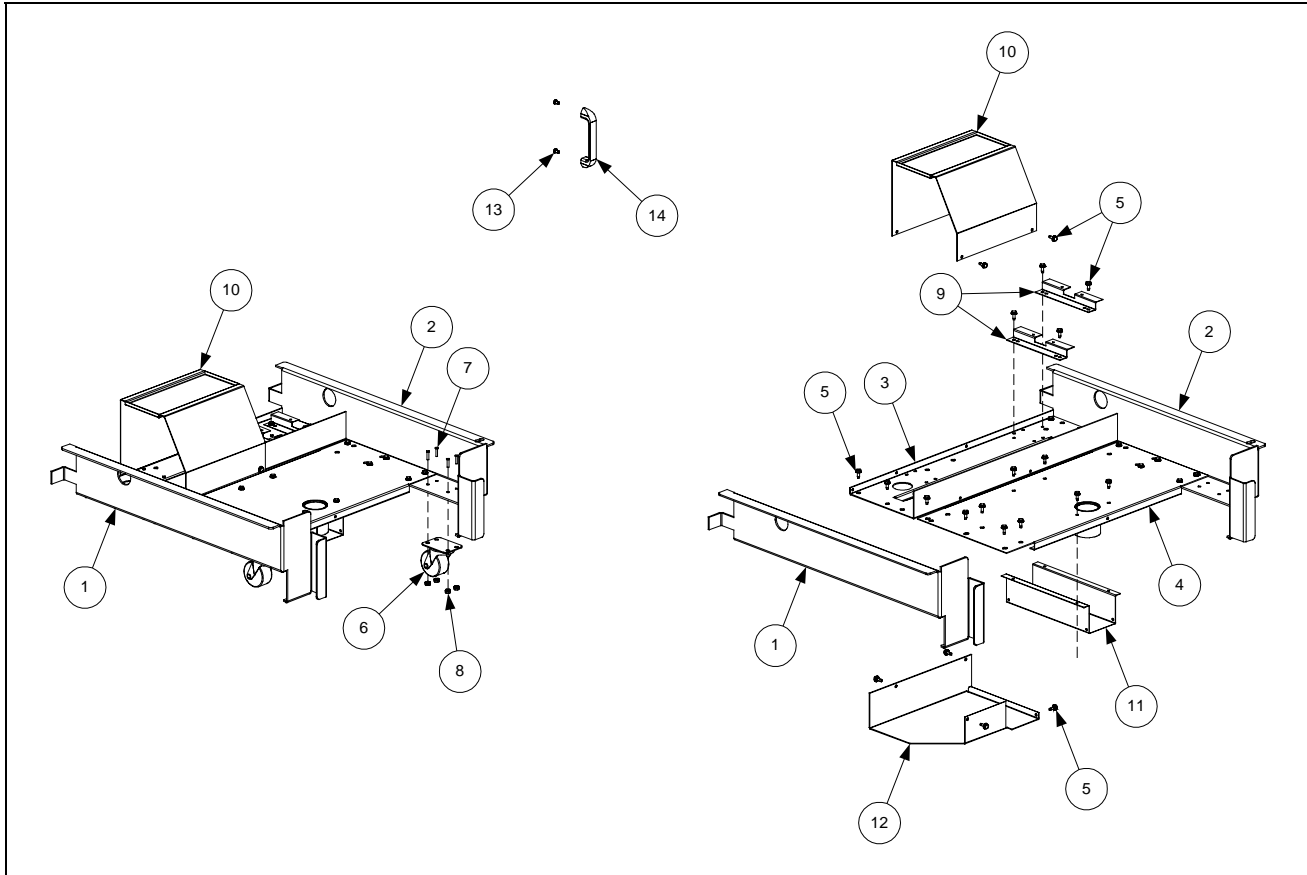

ITEM	PART #	COMPONENT
	806-9619SP	<b>Base Assembly w/o Casters (Items 1- 5)</b>
	806-5954SP	<b>Base Assembly w/Casters (Items 1-8)</b>
1	201-3768	Frame, Left Side
2	202-3768	Frame, Right Side
3	900-5396	Support, Filter Motor
4	823-2289	Support, Filter Pan
5	826-1374	Screw, #10 X ½-inch Hex Washer Head (Pkg. of 25)
6	810-2805	Caster, Swivel 2-inch filter pan
7	809-0021	Stud, 10-32 X ⅝-inch Stainless Steel
8	826-1376	Nut, Keps 10-32 Hex (Pkg. of 10)
9	900-1949	Standoff, Filter Wiring Box (see Page 1-55 for Filter Wiring Box)
10	900-5477	Cover, Motor (August 1997 and later)
*	824-0558	Cover, Motor (Before August 1997)
11	900-7557	Cover, Suction Tube
12	900-9634	Cover, Rear Plumbing (used after August 1999)
13	826-1360	Screw, Handle (Pkg. of 25)
14	810-0180	Handle, Plated Diecast Metal (for use on bases built before August 1997)
*	826-1677	Kit, Pin Extender FPIII
*	KIT1013SP	Kit, FPH50 Filter Module FPIII
*	KIT3258SP	Kit, FPH50 Filter FPIII w/out caster kit

\* Not illustrated.

## 2.13.4 Filter Magic Oil Return Plumbing Components (Including Pump & Motors)

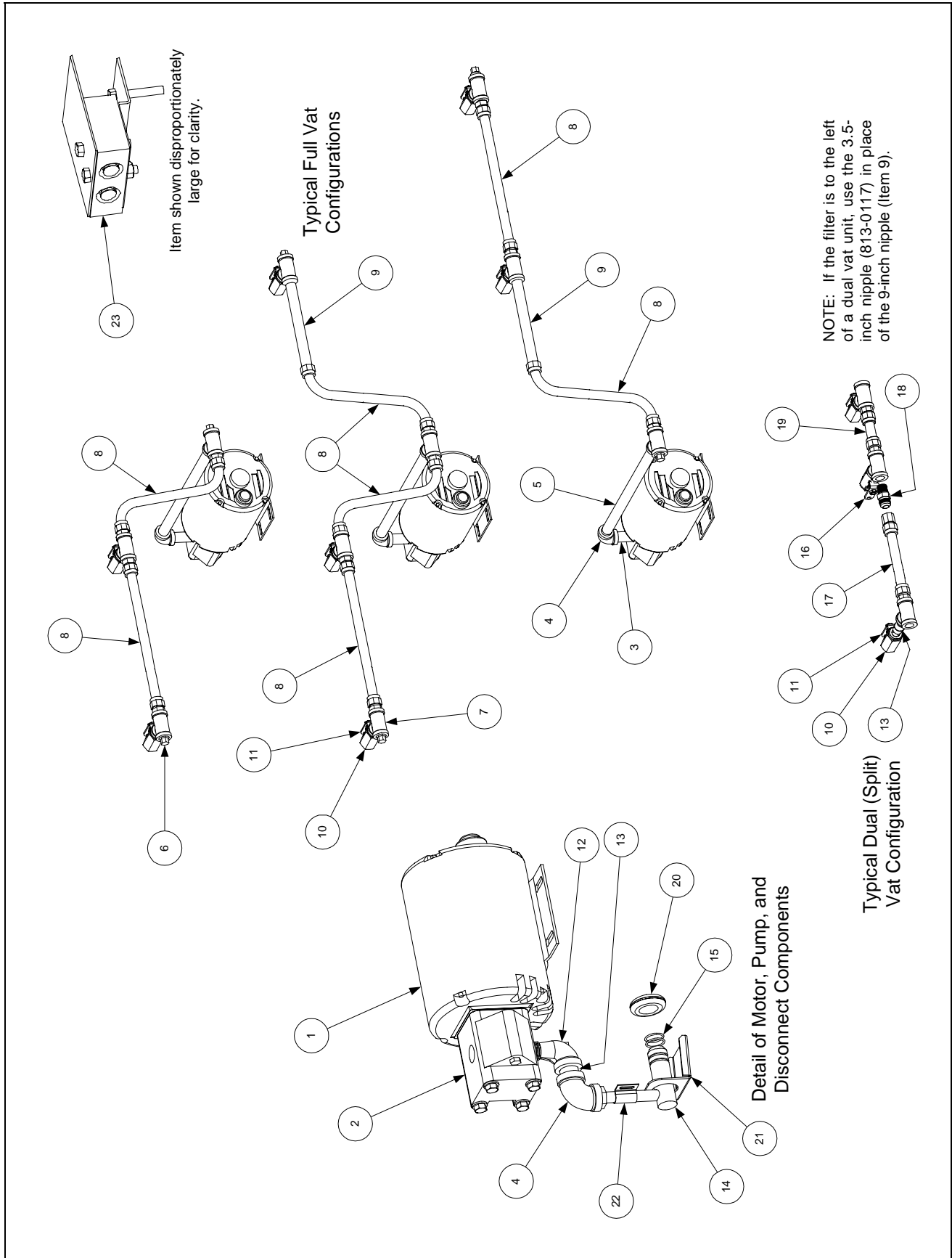

ITEM	PART #	COMPONENT
1		Pump Motor
	826-1712	100-120 VAC 50/60Hz (with gasket 816-0093)
	826-1756	208 VAC 50/60 Hz (with gasket 816-0093)
	826-1270	230-250 VAC 50/60 Hz (with gasket 816-0093)
*	807-11973	Pump Service Kit (gasket, shaft seal, and two O-rings)
*	806-6728SP	Pump Wiring Assembly (this component is furnished with above motors)
2	826-1264	Pump, 4 GPM (15 LPM) (with gasket 816-0093 and mounting screws)
13	826-1360	Screw, Handle (Pkg. of 25)
14	810-0180	Handle, Plated Diecast Metal (for use on bases built before August 1997)
5	813-0368	Nipple, ½-inch x 16-inch
6	813-0156	Pipe Plug, ½-inch
7	813-0003	Tee, ½-inch
8	810-1057	Flexline, ⅝ -inch x 13-inch Oil Return (two female ends)
9	813-0275	Nipple, ½-inch x 9-inch
10	810-0278	Valve, ½-inch Ball
11	902-0883	Handle, Right Valve
	901-0883	Handle, Left Valve
12	813-0165	Elbow, ½-inch x 90° Street
13	813-0022	Nipple, ½-inch Close
14	823-1356	Disconnect Fitting Male
15	826-1392	O-Ring (Pkg. of 5)
16	901-0883	Handle, Left Dual-Vat Valve
17	810-1159	Flexline, 5-inch Oil Return (two female ends)
18	810-1668	Adapter, ⅝ -inch Female to ½-inch Female (used with Item 17)
*	810-1669	Adapter, ⅝ -inch Female to ½-inch Male (used with Item 17)
*	826-1890	Flexline Kit, 7-Inch Oil Return (Items 17, 18, and 810-1669)
19	810-1160	Flexline, 3-inch Oil Return (two female ends)
20	816-0102	Grommet, Oil Diverter
21	900-1472	Diverter, Oil
22	910-1627	Bracket, Male Disconnect Support
23	806-4694SP	Contacting Block Assembly
*	813-0117	Nipple, ¾-inch x 3½-inch
*	807-1600	Thermal Switch, 100-120V Baldor Motors
*	807-1601	Thermal Switch, 200-250V Baldor Motors
*	807-1598	Thermal Switch, 100-120V Magnatek Motors
*	807-1599	Thermal Switch, 200-250V Magnatek Motors
*	810-1062	Wiring Harness, Controller to Filter
*	806-7020SP	Heater Assembly Strip, 120 VAC 50W, 70-inch
	807-1408	Heater Strip Only, 120 VAC 50W, 70-inch
*	806-7021SP	Heater Assembly Strip, 250 VAC 90W, 70-inch
	807-2348	Heater Strip Only, 250 VAC 90W, 70-inch
*	811-0861	Foam Tape Insulation 3-inch wide (by the foot)
*	811-0746	Tape, Aluminum (2-inch x 50-yard (46m) roll)

\* Not illustrated

### 2.13.5 FootPrint III Filter Motors and Pump Plumbing Components

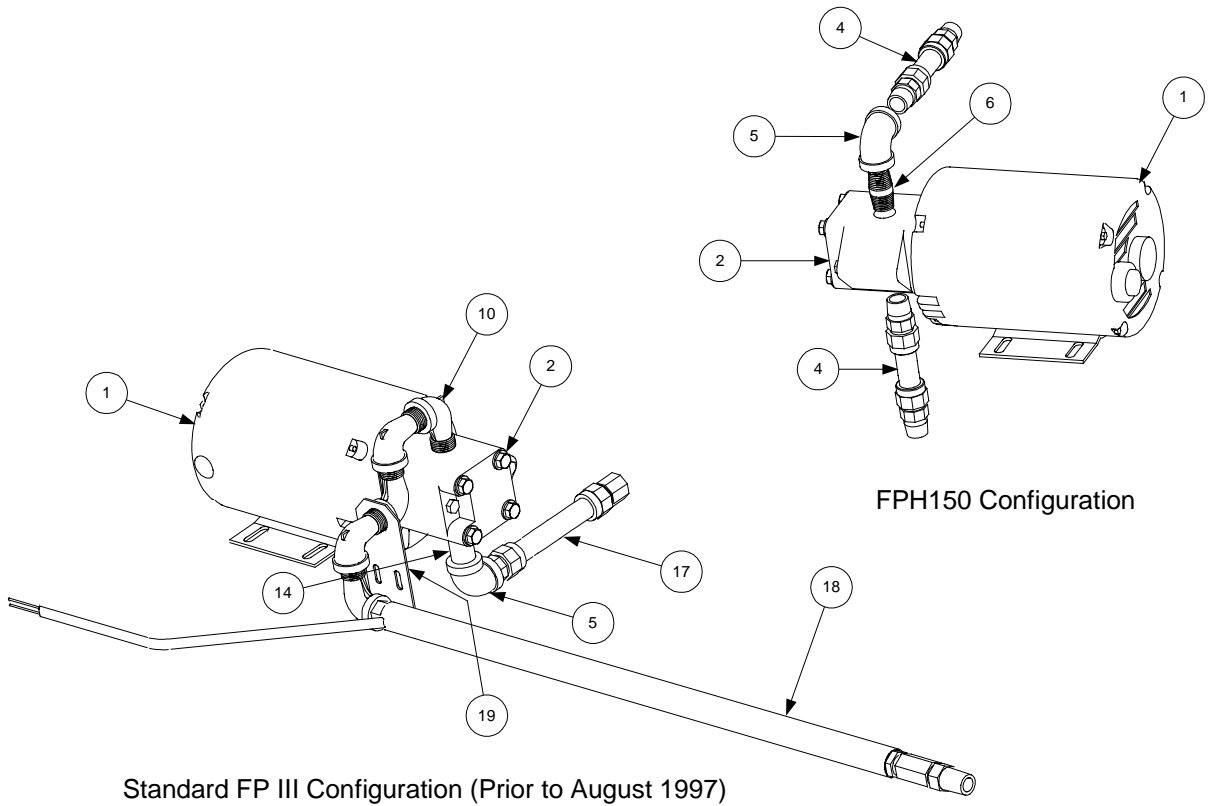

Standard FP III Configuration (Prior to August 1997)

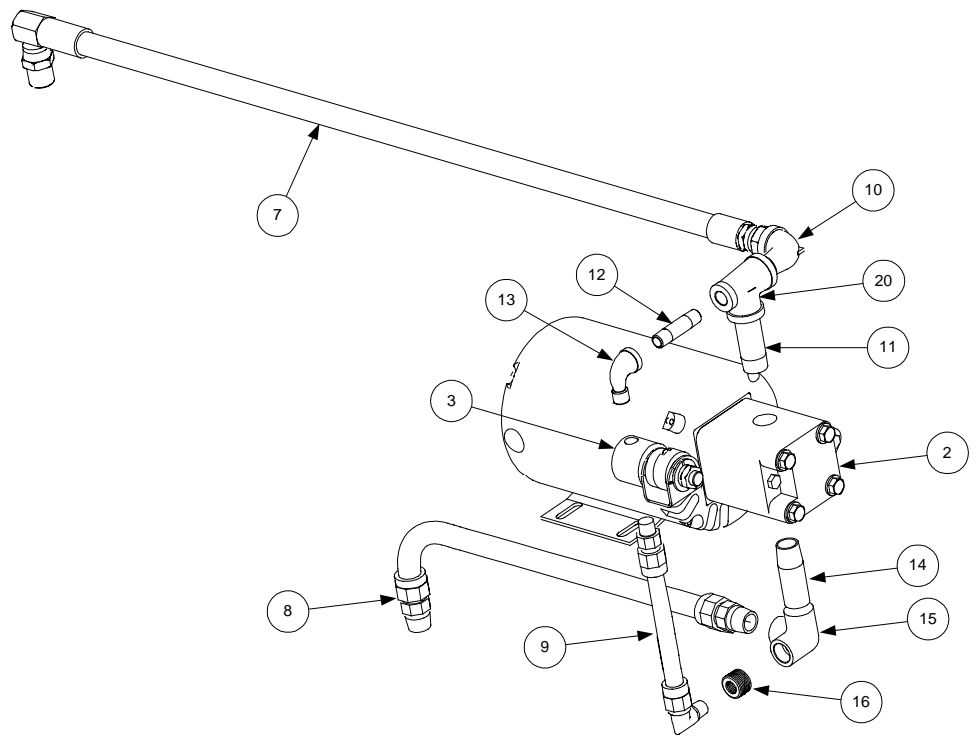

Standard FP III Configuration (August 1997 and Later)



ITEM	PART #	COMPONENT
1		Motor and Gasket Kits
	826-1712	100-120VAC 50/60 Hz (with gasket 816-0093)
	826-1756	208 VAC 50/60 Hz (with gasket 816-0093)
	826-1270	230-250VAC 50/60 Hz (with gasket 816-0093)
*	807-11973	Pump Service Kit (gasket, shaft seal, and two O-rings)
2	826-1264	Pump, 4GPM (15LPM) (includes gasket 816-0093 and mounting screws)
3	807-2484	Valve, Solenoid Vent (145 ohms)
4	810-1160	Flexline, 3-inch Oil Return (two female ends)
5	813-0062	Elbow, ½-inch x 90°
6	813-0022	Nipple, ½-inch x close
7	810-1404	Flexline, Oil Return (pump to rear manifold)
8	810-1057	Flexline, 13-inch Oil Return (two female ends)
9	810-1373	Flexline, Pump Bypass
10	813-0165	Elbow, ½-inch x 90° Street
11	813-0265	Nipple, ½-inch x 2½-inch
12	813-0537	Nipple, ¼-inch x 2-inch
13	813-0543	Elbow, ¼-inch x 90° Street
14	813-0460	Nipple, ½-inch x 3-inch
15	813-0331	Elbow, ½-inch 3-way
16	813-0304	Bushing, ½-inch to ¼-inch Reducer
17	810-1159	Flexline, 5-inch Oil Return (two female ends)
18		Hose, Heated Oil Return
	810-0945	120VAC
	810-1037	202-250VAC
19	900-1958	Support, Oil Return
20	813-0530	Tee, ½-inch x ¼-inch x ½-inch NPT Reducing
*	806-9245SP	Pump Heater Strip Assembly, 120VAC, 25W, 36-inch
*	807-1420	Pump Heater Strip, 120VAC, 25W, 36-inch
*	806-8004SP	Pump Heater Strip Assembly, 120VAC, 40W, 56-inch
	807-1472	Pump Heater Strip, 120VAC, 40W, 56-inch
*	806-7755SP	Pump Heater Strip Assembly, 120VAC, 100W, 72-inch
*	807-2304	Pump Heater Strip, 120VAC, 100W, 72-inch
*	807-1408	Pump Heater Strip, 120VAC, 50W, 70-inch
*	826-1668	Heat Tape Kit, 120VAC 20w
*	826-1669	Heat Tape Kit, 208-250VAC 20w
*	816-0093	Gasket, Pump Motor
*	807-1600	Thermal Switch, 100-120V Baldor Motors
*	807-1601	Thermal Switch, 200-250V Baldor Motors
*	807-1598	Thermal Switch, 100-120V Magnatek Motors
*	807-1599	Thermal Switch, 200-250V Magnatek Motors
*	806-6728SP	Pump Wiring Assembly, FPH150
*	810-1062	Wiring Harness, Controller to Filter
*	811-0861	Foam Tape Insulation 3-inch wide (by the foot)
*	811-0746	Tape, Aluminum (2-inch x 50-yard (46m) roll)

\* Not illustrated

## 2.13.6 FootPrint III with Power Shower Oil Return Plumbing Components

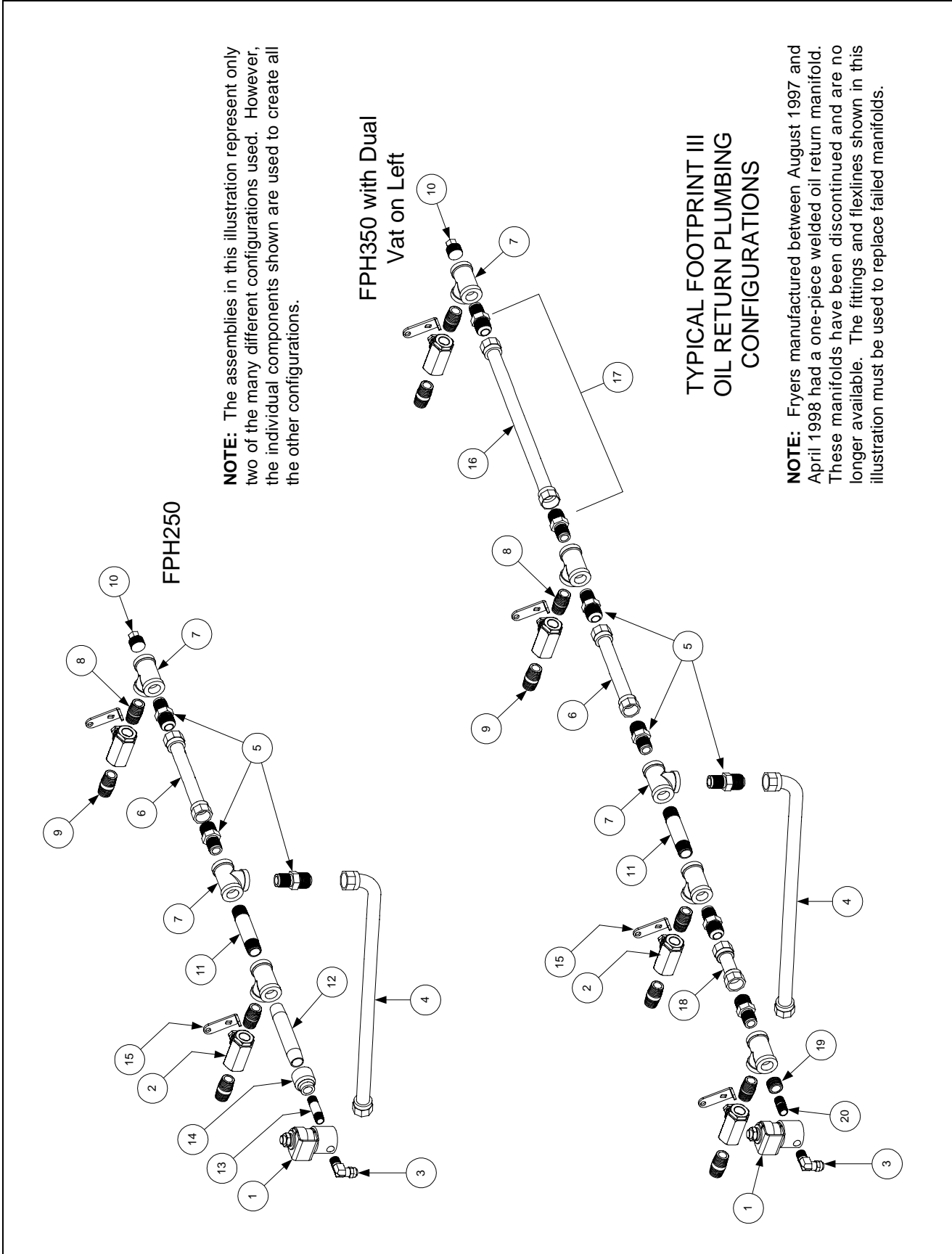

ITEM	PART #	COMPONENT
1	807-2484	Valve, Solenoid Vent
2	810-0278	Valve, ½-inch NPT Ball
3	810-1372	Fitting, ¼-inch NPT x 90°
4	810-1069	Flexline, Oil Return, 29.5-inch
5	810-1668	Adapter, ½-inch NPT Male (converts female to male)
6	810-1680	Flexline, Oil Return, 6.5-inch
7	813-0003	Tee, ½-inch NPT
8	813-0022	Nipple, ½-inch NPT x Close
9	813-0087	Nipple, ½-inch NPT x 1.5-inch
10	813-0156	Plug, ½-inch NPT
11	813-0247	Nipple, ½-inch NPT x 3.5-inch
12	813-0251	Nipple, ½-inch NPT x 4.5-inch
13	813-0537	Nipple, ¼-inch NPT x 2-inch
14	813-0555	Reducer, ½-inch to ¼-inch NPT
15	902-0883	Handle, Oil Return Valve (Right)
	901-0883	Handle, Oil Return Valve (Left)
16	810-1057	Flexline, Oil Return, 13.0-inch
17	806-9437SP	Flexline Assembly, Oil Return, 15.5-inch (2 of Item 5 plus Item 16)
18	810-1160	Flexline, Oil Return, 3.0-inch
19	813-0304	Reducer Bushing, ½-inch to ¼-inch NPT
20	813-0016	Nipple, ¼-inch NPT x Close
*	826-1720	Vent Tube, Teflon, ⅜-inch O.D. x 24-inches
*	811-0932	Vent Tube, Teflon, ⅜-inch O.D. per foot
*	816-0224	Insulation, Rubber 3-inch x 6-inch
<p><b>NOTE:</b> The following Oil Return Flexlines and miscellaneous components may also be used in some specially configured units. When ordering a flexline, it is recommended that the line be measured (from outside of flare fitting to outside of flare fitting) to ensure the correct item is ordered.</p>		
*	810-1160	Flexline, Oil Return, 3.0-inch
*	810-1339	Flexline, Oil Return, 4.5-inch
*	810-1159	Flexline, Oil Return, 5.0-inch
*	810-1067	Flexline, Oil Return, 8.5-inch
*	810-1043	Flexline, Oil Return, 9.5-inch
*	810-1055	Flexline, Oil Return, 11.5-inch
*	810-1369	Flexline, Oil Return, 17.5-inch
*	810-1068	Flexline, Oil Return, 21.5-inch
*	810-1069	Flexline, Oil Return, 29.5 inch
*	810-1056	Flexline, Oil Return, 52.5-inch
*	810-1669	Adapter, ½-inch NPT Female (converts male to female)
*	901-0883	Handle, Oil Return Valve (Left) (mirror of Item 15 above)
*	902-0883	Handle, Oil Return Valve (Right)

\* Not illustrated

## 2.13.7 FootPrint III with Rear Flush Oil Return Plumbing Components, Standard

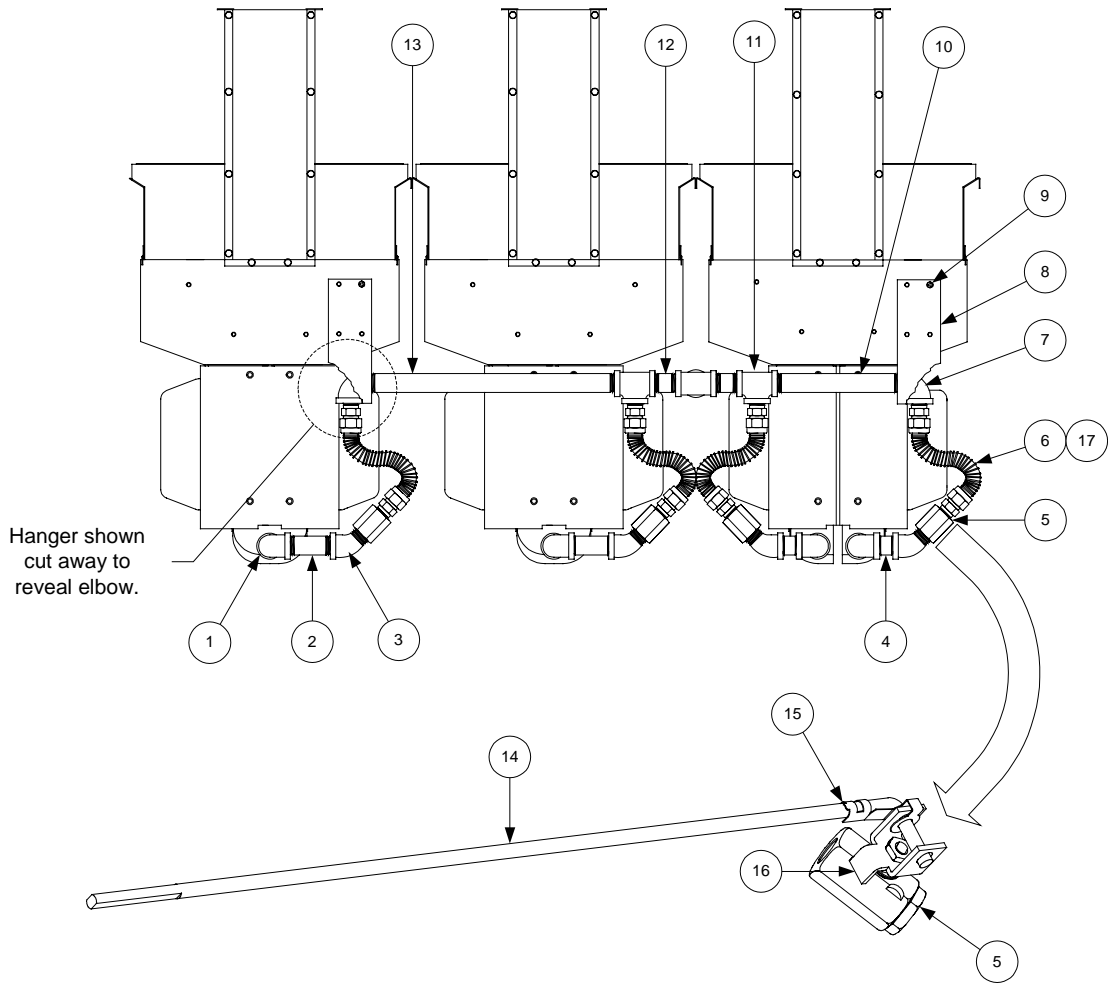

**FPH350-2L Rear Flush (Typical)**

See Page 2-47 for KFCH50 Rear Flush Oil Return Components.

See Page 2-48 for Oil Return Handle Components.

ITEM	PART #	COMPONENT
1	813-0165	Elbow, ½-inch x 90° Street
2	813-0265	Nipple, ½-inch x 2½-inch
3	813-0342	Elbow, ½-inch x 45° Street
4	813-0087	Nipple, ½-inch x 1½-inch
5	810-0278	Valve, ½-inch Ball
*	810-1003	Valve, ½-inch 180° 3-way Ball
6	810-1067	Flexline, 8.5-inch Oil Return
7	813-0062	Elbow, ½-inch x 90°
8	900-2783	Hanger, Rear Flush
9	809-0417	Nut, ¼-20 Serrated Flange
10	813-0320	Nipple, ½-inch x 2-inch
11	813-0003	Tee, ½-inch
12	813-0298	Nipple, ½-inch x 2-inch
13	813-0360	Nipple, ½-inch x 14-inch
14	810-1209	Shaft, Rear Flush Valve
15	809-0601	Clip, Rod End Clevis
16	901-2772	Handle, Left Rear Flush Valve
*	902-2722	Handle, Right Rear Flush Valve
17	810-1668	Adapter, ½-inch NPT Male (converts female to male)
*	810-1056	Flexline, 56-inch Oil Return
*		Strip, Heater
	806-8065SP	100VAC, 18-inch (46cm), 25 Watt
	806-6730SP	100VAC, 56-inch (142cm), 40 Watt
	806-5933SP	120VAC, 18-inch (46cm), 25 Watt
	806-8004SP	120VAC, 56-inch (142cm), 40 Watt
	806-5934SP	200-250VAC, 18-inch (46cm), 25 Watt
	806-5932SP	200-250VAC, 36-inch (91 cm), 45 Watt
	806-6732SP	200-250VAC, 56-inch (142cm), 70 Watt
*	811-0861	Foam Tape Insulation 3-inch wide (by the foot)
*	811-0746	Tape, Aluminum (50-yard (46m) roll)

\* Not illustrated

## 2.13.8 FootPrint III with Rear Flush Oil Return Plumbing Components, KFC

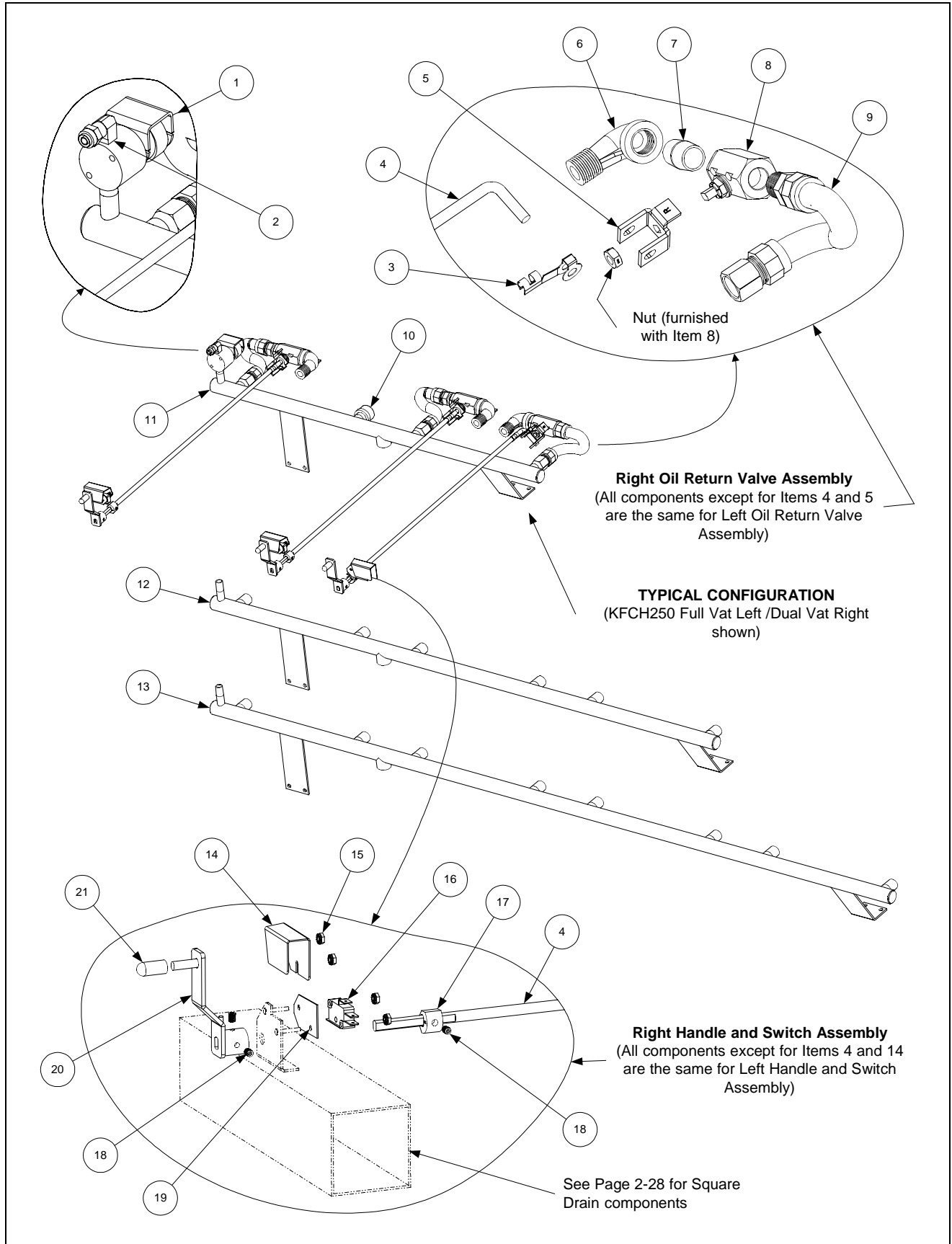

ITEM	PART #	COMPONENT
1	807-2484	Valve, Solenoid Vent
2	810-1372	Elbow, 90° x ¼-inch NPT x ⅜-inch Tube
*	811-0932	Vent Tube, Teflon, ⅜-inch O.D. per foot
3	809-0601	Clip, Rod End Clevis
4		Shaft, Rear Flush Valve
	810-1767	For use in <b>left</b> oil return valve assemblies (see illustration below).
	810-1766	For use in <b>right</b> oil return valve assemblies (see illustration below).
5		Handle, Rear Flush Valve
	901-2772	For use in <b>left</b> oil return valve assemblies.
	902-2772	For use in <b>right</b> oil return valve assemblies.
6	813-0165	Elbow, 90° x ½-inch Street
7	813-0022	Nipple, ½-inch Close
8	810-0278	Valve, ½-inch Ball
*	900-2935	Nut, Oil Return Valve Retainer
*	810-1003	Valve, ½-inch 180° 3-way Ball
9	806-9828SP	Flexline Assembly, 9-inch Oil Return
10	813-0469	Cap, ½-inch Pipe
11	810-1360	Manifold, KFCH250 Rear Flush Oil Return
12	810-1357	Manifold, KFCH350 Rear Flush Oil Return
13	810-1378	Manifold, KFCH450 Rear Flush Oil Return
14		Cover, FPH50 Rear Flush Oil Return Microswitch
	901-2214	For use in <b>left</b> handle and switch assemblies.
	902-2214	For use in <b>right</b> handle and switch assemblies.
15	826-1366	Nut, 4-40 Keps Hex (Pkg. of 25)
16	807-2103	Microswitch
17	810-1186	Cam, Filter System Microswitch
18	826-1377	Setscrew, 10-32 x ¼-inch (Pkg. of 25)
19	816-0220	Insulation, Microswitch
20		Handle, Rear Flush
	823-2295	For use in Non-CE applications (see illustration below).
	823-2259	For use in CE applications only (see illustration below).
21	812-1253SP	Cover, Rear Flush Handle

**NOTE:** *Left* and *right* refer to the fryer as viewed from the front when facing the fryer.

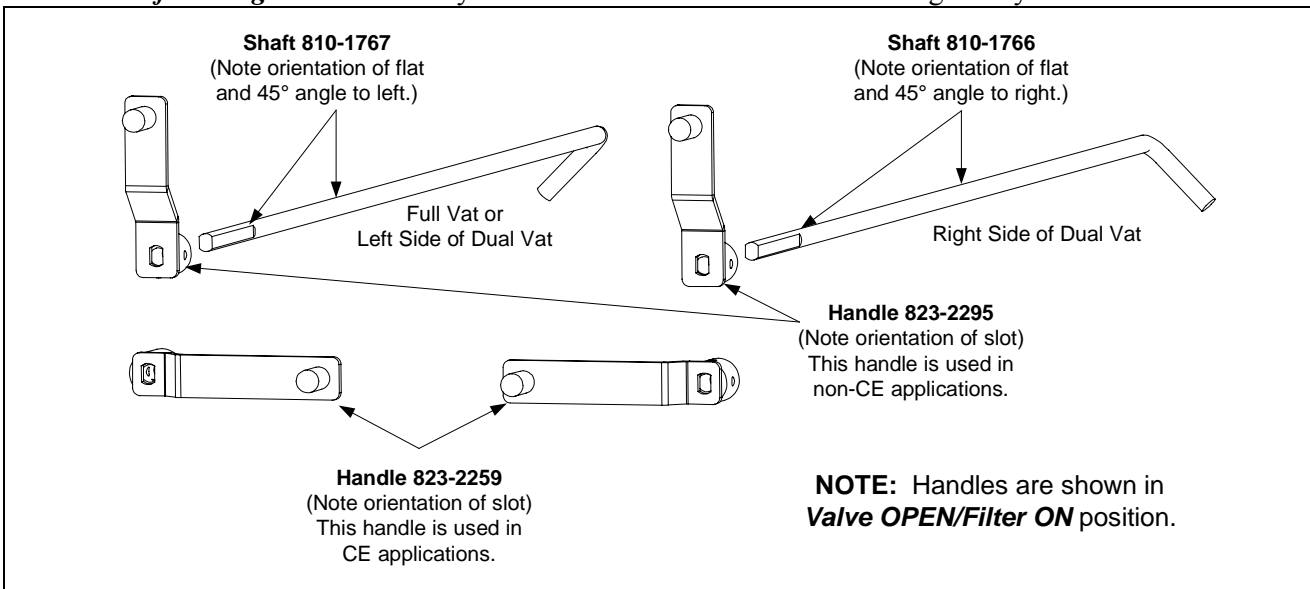

### 2.13.9 FPH150-2 Oil Return Plumbing

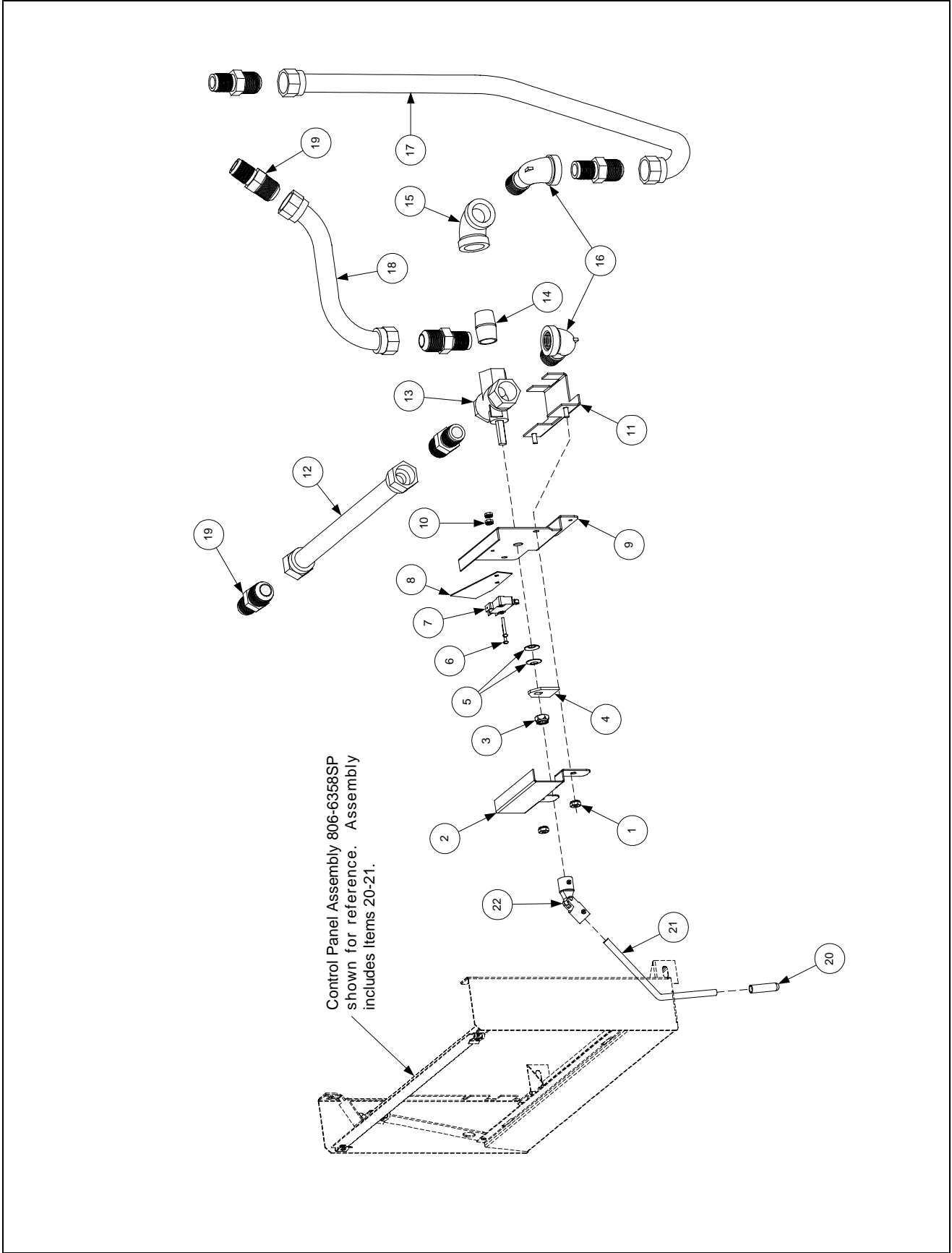



ITEM	PART #	COMPONENT
	806-6309SP	FPH150-2 Oil Return Plumbing Assembly (Items 1-19)
1	826-1376	Nut, 10-32 Keps (Pkg. of 10)
2	900-2110	Cover, Switch
3	809-0056	Locknut, 5/16-inch x 24 Nylon
4	910-2311	Switch, Actuator
5	809-0519	Washer, 5/16 Spring (2 each)
6	826-1359	Screw, 4-40 x 3/4-inch (Pkg. of 10)
7	807-2104	Microswitch, Roller-activated
8	812-0442	Insulation, Microswitch
9	900-2268	Mount, Microswitch
10	826-1366	Nut, 4-40 Keps (Pkg. of 25)
11	806-8342	Bracket, Oil Return Valve
12	810-1055	Flexline, Oil Return, 11.5-inch
13	810-1003	Valve, 1/2-inch NPT 3-way Ball
14	813-0022	Nipple, 1/2-inch NPT x Close
15	813-0062	Elbow, 1/2-inch x 90°
16	813-0165	Elbow, Street, 1/2-inch x 90°
17	810-1068	Flexline, Oil Return, 21.5-inch
18	810-1067	Flexline, Oil Return, 8.5-inch
19	810-1668	Adapter, 1/2-inch NPT Male (converts female to male)
	806-6358	FPH150-2 Control Panel Assembly, Complete (including Items 20-22)
20	810-0677	Grip, Oil Return Handle
21	910-2312	Handle (Rod), Oil Return
22	810-1115	U-Joint

### 2.13.10 Oil Return Handle Assembly, Filter Magic & Standard FootPrint III

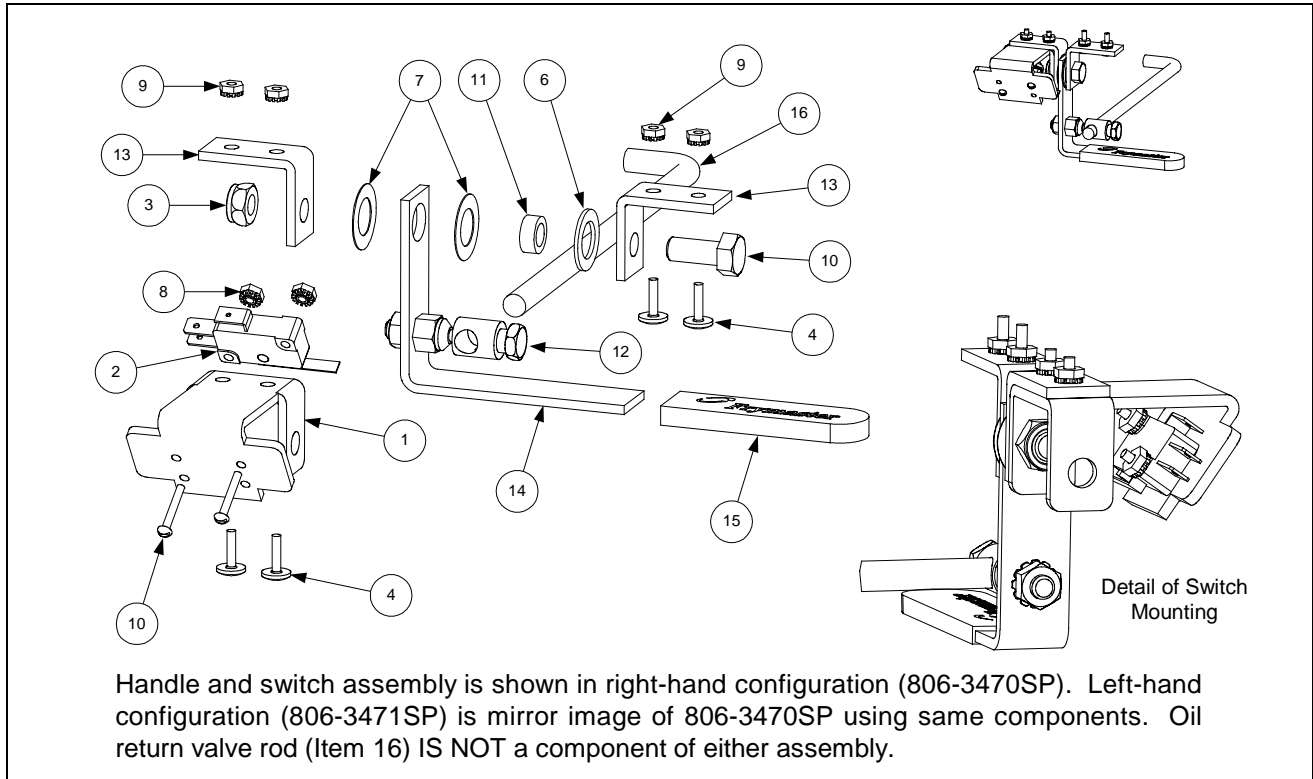

ITEM	PART #	COMPONENT
	806-3470SP	Handle and Switch Assembly, Right (Items 1-15)
	806-3471SP	Handle and Switch Assembly, Left (Items 1-15)
1	200-0821	Bracket, Handle and Microswitch
2	807-2103	Microswitch
3	809-0056	Nut, 5/16 – 24, Hex Head, Nylon Lock
4	809-0103	Screw, 8-32 x 1/2" Slotted Truss Head
5	809-0142	Screw, 5/16 – 24 x 3/4" Hex Head
6	809-0200	Washer, Flat
7	826-1381	Washer, Nylatron (Pkg of 10)
8	826-1366	Nut, 4-40 Hex Keps (Pkg of 25)
9	809-0247	Nut, 8-32 Hex Keps
10	826-1359	Screw, 4-40 x 3/4" Slot Head (Pkg of 25)
11	810-0220	Spacer, Tubular, .493 OD
12	810-0285	Swivel Fitting, Oil Return Valve Linkage
13	810-1999	Bracket, Valve Handle
14	920-0831	Handle, Oil Return
15	814-0047	Sleeve, Handle
16	910-0832	Rod, Oil Return Valve (must be ordered separately from assemblies)
*	810-0278	Valve, Ball 1/2-inch
*	826-1878	Kit, Brace Filter

\* Not illustrated

### 2.13.11 Power Shower Assemblies (All Models)

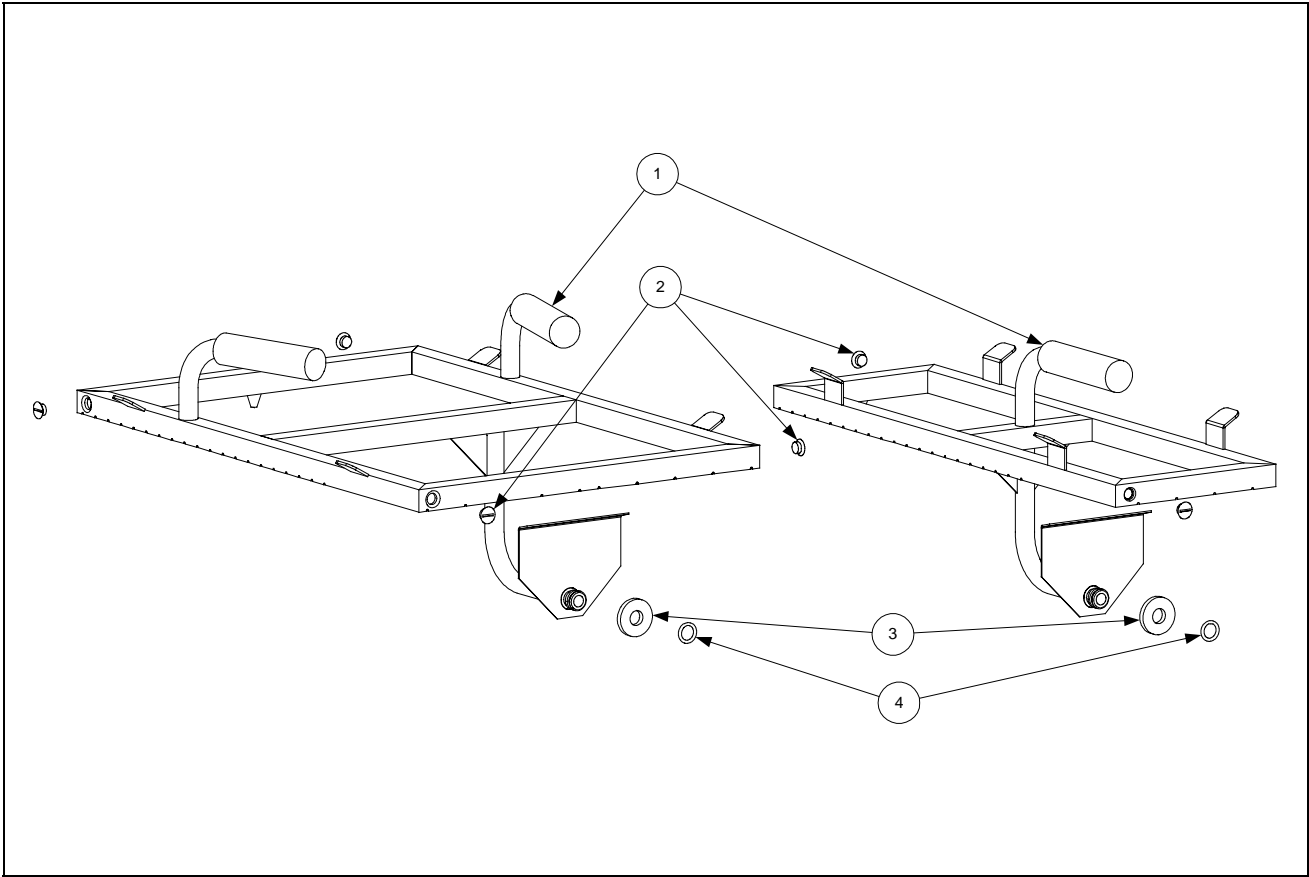

ITEM	PART #	COMPONENT
	806-4442SP	<b>Power Shower Assembly, Full Vat, Complete</b>
	806-4476SP	<b>Power Shower Assembly, Dual Vat, Complete</b>
1	814-0001	Grip, Handle
2	809-0415	Screw, Cleanout
3	826-1390	Seal (Gasket) (pkg of 5)
4	826-1344	O-Ring (pkg of 5)

## 2.13.12 Oil Disposal Systems Plumbing

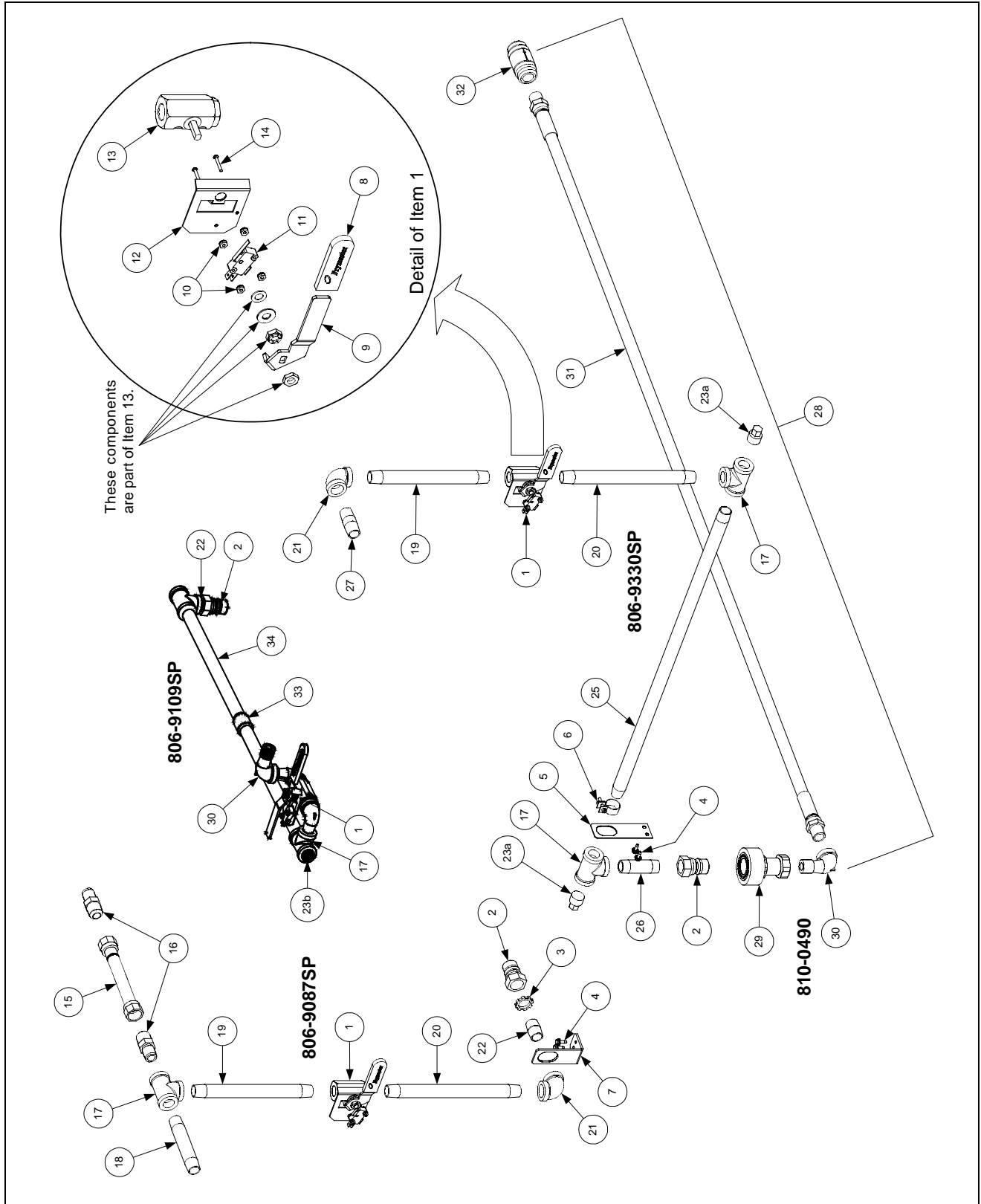

ITEM	PART #	COMPONENT
	806-9087SP	Oil Disposal Plumbing Assembly (side discharge configuration)
	806-9330SP	Oil Disposal Plumbing Assembly (rear discharge configuration) H50 oil Return
1	806-8762SP	Ball Valve with Microswitch Assembly
*	WIR0315SP	Wire Assembly, Ball Valve Microswitch
2	810-0487	Quick Disconnect, 1/2-inch Male
3	809-0454	Nut, 1/2-inch Conduit (mounts between Item 2 and Item 6)
4	826-1374	Screw, #10 x 1/2-inch Hex Head (Pkg of 25)
5	910-8809	Bracket, Oil Disposal Mounting (rear connection configuration)
6	809-0951	Clamp, Hose (limits movement of plumbing through mounting bracket)
7	910-8085	Bracket, Oil Disposal Mounting (side connection configuration)
8	814-0047	Sleeve, Valve Handle
9	900-5953	Handle, Oil Disposal Valve
10	809-0237	Nut, 4-40 Hex Head Keps
11	807-2103	Microswitch, Roller Activated
12	900-8057	Bracket, Microswitch Mounting
13	810-0278	Valve, 1/2-inch Gemini (without handle)
*	900-2935	Nut, Oil Return Valve Retainer
14	809-0354	Screw, 4-40 x 3/4-inch Round Head
15	810-1680	Flexline, 6.5-inch Oil Return
16	810-1668	Adapter, 1/2-inch NPT Male (converts female to male)
17	813-0003	Tee, 1/2-inch x 1/2-inch x 1/2-inch
18	813-0251	Nipple, 1/2-inch x 5-inch
19	813-0320	Nipple, 1/2-inch x 8-inch
20	813-0275	Nipple, 1/2-inch x 9-inch
21	813-0062	Elbow, 1/2-inch x 90°
22	813-0022	Nipple, 1/2-inch x Close
23a	813-0156	Plug, 1/2-inch Pipe Hex Head
23b	813-0463	Plug, 1/2-inch Pipe Counter Sink
24	813-0087	Nipple, 1/2-inch x 1 1/2-inch
25	813-0541	Nipple, 1/2-inch x 2 1/2-inch
26	813-0265	Nipple, 1/2-inch x 2 1/2-inch
27	813-0298	Nipple, 1/2-inch x 2-inch
28**	806-9178SP	Hose Assembly, Oil Disposal (Items 29-32) Sonic
29	810-0490	Quick Disconnect Fitting, 1/2-inch Female
30	813-0165	Elbow, 1/2-inch x 1/2-inch 90° Street
31	810-1434	Hose Assembly, 66-inch Oil
32	810-0667	Check Valve, 1/2-inch
33	813-0037	Coupling, 1/2 NPT x 1-1/8
34	813-0360	Nipple, 1/2 x 14.00-inch NPT BM Pipe
*	KIT3578SP	Kit, Oil Return FPH50 (Sonic)
*	806-9109SP	Kit, Oil Return FM
*	WIR0315SP	Wire Assembly Sonic Oil Disposal

\* Not illustrated.

\*\* Item 28 is NOT a component of either 806-9087SP or 806-9330SP.

### 2.13.13 Assembly Wand Plumbing Japan

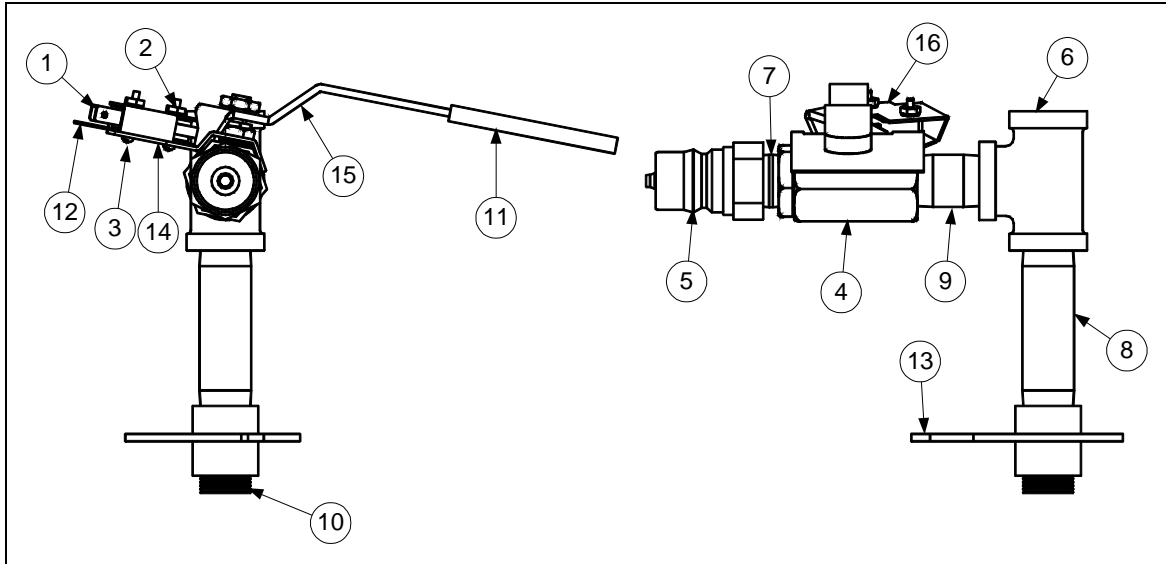

ITEM	PART #	COMPONENT
	806-9700SP	Plumbing Assembly, Japan Wand
1	807-2103	Switch, CE Micro
2	826-1366	Nut, 4-40 (Pkg. of 25)
3	826-1359	Screw, 4-40 x 3/4 (Pkg. of 25)
4	810-0278	Valve, 1/2-inch Ball
5	810-0487	Coupling, Male
6	813-0003	Tee, 1/2 x 1/2 x 1/2
7	813-0002	Nipple, 1/2 x Close NPT
8	813-0156	Plug, 1/2 NPT
9	813-0247	Nipple, 1/2 x 3 1/2-inch NPT
10	813-0298	Nipple, 1/2 x 2-inch NPT
11	814-0047	Sleeve, Handle Valve Red w/ Logo
12	816-0220	Insulation, RF Switch
13	823-2029	Support, Oil Return
14	900-1862	Bracket, Microswitch Mounting 1/2 Ball Valve
15	900-2839	Handle, Valve Wand Japan
16	900-2849	Cover, Wand Microswitch Japan

## 2.13.14 Oil Disposal Wand Assembly

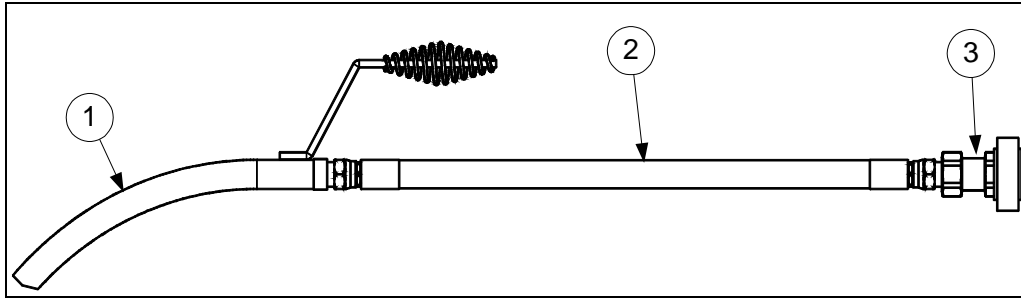

ITEM	PART #	COMPONENT
	806-7459	Assembly, Oil Disposal Wand
1	810-0603	Wand, FB Filter
2	810-1471	Hose, 24 FPH50 Japan
3	810-0490	Quick Disconnect, 1/4-inch Female

## 2.14 Frypot Assemblies and Component Parts

### 2.14.1 Replacement Frypots and Frypot Insulation Kits

ITEM	PART #	COMPONENT
		<b>Replacement Frypot Assemblies, Complete</b>
	106-1026	Full Vat, Non-Filter, Natural Gas
	106-1049SP	Full Vat, Power Shower & Rear Flush, Natural Gas
	106-1050SP	Full Vat, Power Shower & Rear Flush, Propane Gas
	106-1047SP	Full Vat, Power Shower, w/Four Holes, Natural Gas* Replaced by 106-1049SP
	106-1048SP	Full Vat, Power Shower, w/Four Holes, Propane Gas* Replaced by 106-1050SP
	106-1043SP	Full Vat, Power Shower, Manufactured Gas
	106-1058	Dual Vat, Power Shower, Natural Gas
	106-1079SP	Dual Vat, Power Shower & Rear Flush, Natural Gas
	106-1080SP	Dual Vat, Power Shower & Rear Flush, Propane Gas
	106-1066SP	Dual Vat, Power Shower, Manufactured Gas
	106-1070SP	Dual Vat, Rear Flush (KFC, Natural Gas)
	106-1071SP	Dual Vat, Rear Flush (KFC, Propane Gas)
		<b>Replacement Insulation Kits</b>
	826-0929	Full Vat, Complete
	826-0931	Full Vat, Burner Only
	826-0930	Dual Vat, Complete
	826-0932	Dual Vat, Burner Only
	826-1881SP	Hardware Kit, FV Frypot
	826-1882	Hardware Kit, DV Frypot
	106-1019SP	Flue Assembly, FV
	106-1018SP	Flue Assembly, DV
	823-3315	Retainer W/A, Inner Left Front FV
	823-3316	Retainer W/A, Inner Right Front FV

\* Used only on fryers with non-Frymaster remote computers. (Jack In the Box and Foodmaker)

**NOTE:** See pages 2-58 and 2-60 for replacement burners and replacement burner rails.

## 2.14.2 Full Vat Frypot Assembly, Component Parts

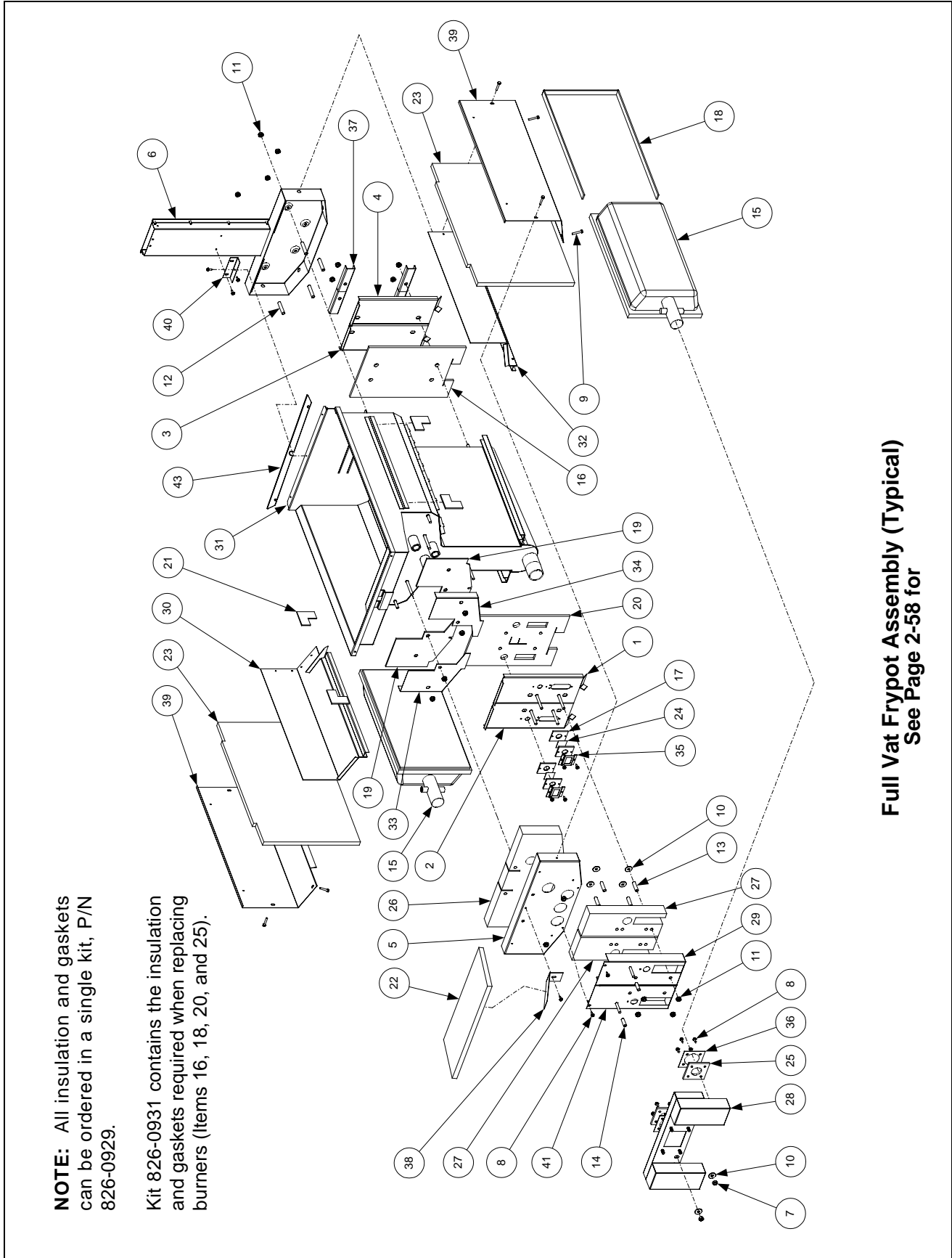



ITEM	PART #	COMPONENT
		<b>Full Vat Frypot Assembly, Complete</b> (see Page 2-58 for P/Ns)
1	823-3316	Retainer, Lower Front Insulation, Right ( <i>before 09/01 use 200-0934</i> )
2	823-3315	Retainer, Lower Front Insulation, Left ( <i>before 09/01 use 200-0935</i> )
3	200-0936	Back, Combustion Chamber, Left
4	200-0937	Back, Combustion Chamber, Right
5	200-2227	Retainer, Upper Front Insulation
6	106-1019SP	Flue Assembly, Full Vat ( <i>before 09/01 use 806-5859SP</i> )
7	826-1372	Nut, ¼-20 Hex Head Grip (Pkg of 10)
8	826-1371	Screw, #8 x ½-inch Hex Head Drill Point (Pkg of 25)
9	809-0362	Screw, # 8 x 1¼-inch Hex Head Drill Point
10	826-1383	Washer, ¾-inch OD x ¼-inch ID Steel (Pkg of 5)
11	809-0804	Nut, ¼-20 Washer-Face Lock
12	810-0406	Spacer, ¼-inch x 1½ -inch Long
13	826-1340	Spacer, ¼-inch x 1 <sup>3</sup> / <sub>16</sub> -inch Long (Pkg of 10)
14	810-0500	Spacer, ¼-inch x 1 <sup>5</sup> / <sub>16</sub> -inch Long
15	826-1072	Burner, Natural or Propane, Universal ( <i>use 826-1073 for Mfg gas</i> )
16	812-0355	Insulation, Lower Rear
17	812-0356	Insulation, Sight Glass Gasket
18	816-0577	Insulation, Burner (½-inch x 36-inches)
19	812-0404	Insulation, Front Seal (for left and right)
20	812-0457	Insulation, Lower Front
21	812-0706	Insulation, Upper Burner Rail
22	812-0993	Insulation, Upper Oil Zone
23	812-1029	Insulation, Combustion Chamber Side
24	814-0048SP	Sight Glass
25	816-0057	Gasket, Plenum Chamber
26	816-0560	Insulation, Upper Front
27	816-0561	Insulation, Combustion Chamber, Outer
28	823-0969	Plenum, Full Vat ( <i>for CE units, use 823-1048</i> )
29	823-3304	Combustion Chamber Outer Front, Right ( <i>before 09/01 use 823-1169SP</i> )
30	823-1777	Burner Rail, Left
31		Frypot, Full Vat (shown for assembly reference only)
32	823-3142	Burner Rail, Right
33	824-0863	Retainer, Left Front Seal Insulation
34	824-0864	Retainer, Right Front Seal Insulation
35	900-1031	Retainer, Sight Glass, ¾-inch
36	900-1049	Retainer, Plenum Chamber Gasket
37	900-1221	Retainer, Rear Insulation and Combustion Chamber Back
38	900-1515	Brace, Upper Oil Zone Insulation
39	900-4452	Retainer, Combustion Chamber Side Insulation
40	930-0818	Bracket, Flue to Frypot Connection
41	823-3305	Combustion Chamber Outer Front, Left ( <i>before 09/01 use 823-1169ISP</i> )
42	809-0500	Screw, #10 x ½-inch Hex Washer Head
43	900-4253	Strip, Fluecap Retainer
*	813-0156	Plug, ½-inch NPT BM (for blocking unneeded ports)
*	813-0336	Plug, ½-inch SS (for blocking unneeded ports)
*	910-2474	Pot-to-Pot Gap Clip
*	900-0857	Brace, Frypot to Cabinet

\*Not illustrated.

### 2.14.3 Dual Vat Frypot Assembly, Component Parts

**NOTE:** All insulation and gaskets can be ordered in a single kit, P/N 826-0930.

Kit 826-0932 contains the insulation and gaskets required when replacing burners (Items 13, 15, 17, and 23).

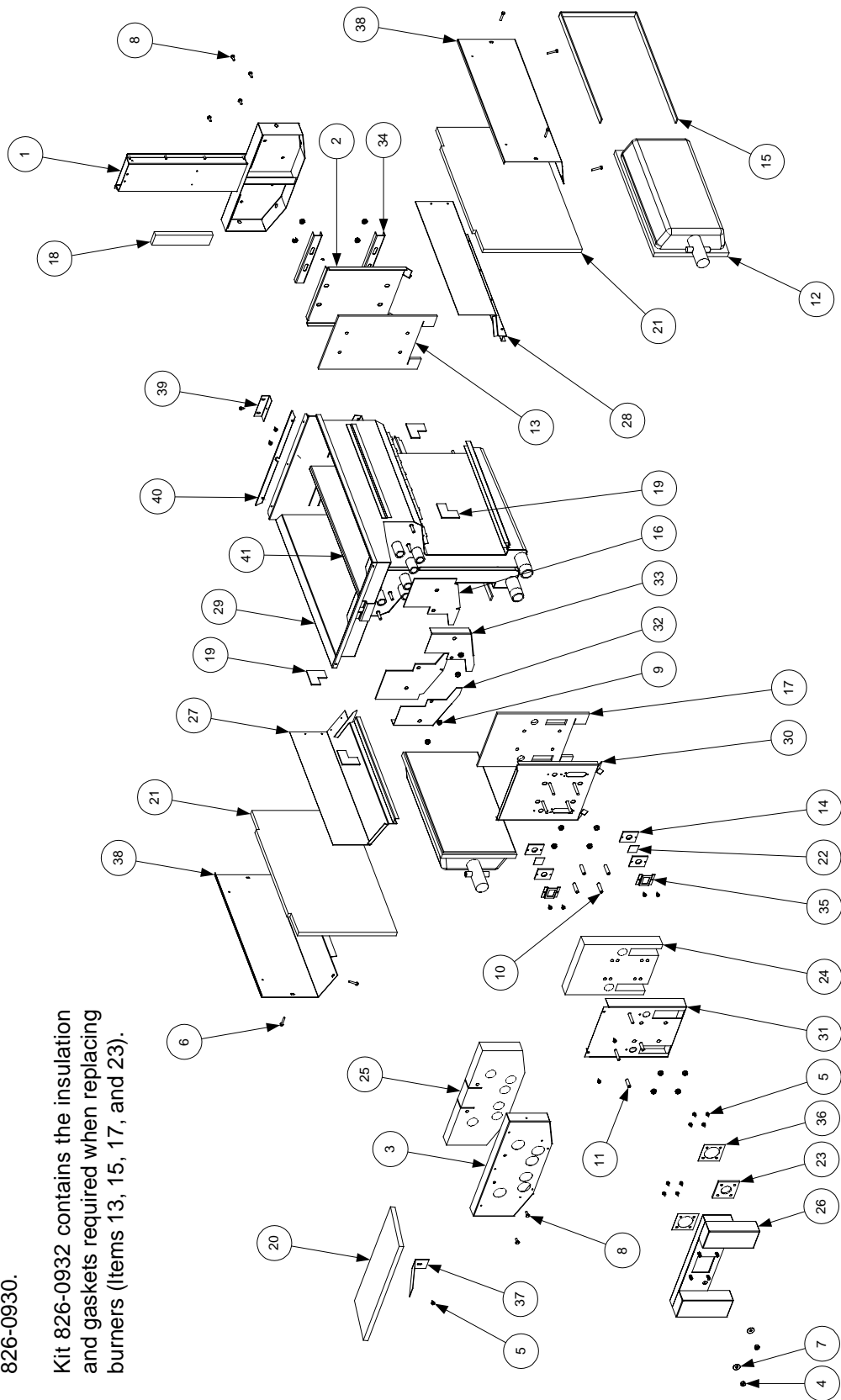

**Dual Vat Frypot Assembly (Typical)**  
See Page 2-58 for P/N's

ITEM	PART #	COMPONENT
		<b>Dual Vat Frypot Assembly, Complete</b> (see Page 2-58 for P/Ns)
1	106-1018SP	Flue Assembly, Dual Vat ( <i>before 09/01 use 806-5860SP</i> )
2	200-0941	Back, Combustion Chamber
3	200-2229	Retainer, Upper Front Insulation
4	826-1372	Nut, ¼-20 Hex Head Grip (Pkg of 10)
5	809-0360	Screw, #8 x ¾-inch Slotted Hex Washer Head
6	809-0362	Screw, # 8 x 1¼-inch Hex Head Drill Point
7	826-1383	Washer, ¾-inch OD x ¼-inch ID Steel (Pkg of 5)
8	809-0500	Screw, #10 x ½-inch Hex Washer Head
9	809-0804	Nut, ¼-20 Washer-Face Lock
10	826-1340	Spacer, ¼-inch x 1 <sup>3</sup> / <sub>16</sub> -inch Long (Pkg. of 10)
11	810-0500	Spacer, ¼-inch x <sup>15</sup> / <sub>16</sub> -inch Long
12	826-1072	Burner, Natural or Propane, Universal ( <i>use 826-1073 for Mfg gas</i> )
13	812-0354	Insulation, Lower Rear
14	812-0356	Insulation, Sight Glass Gasket
15	816-0577	Insulation, Burner (½-inch x 36-inches)
16	812-0404	Insulation, Front Seal (for left and right)
17	812-0458	Insulation, Lower Front
18	812-0688	Insulation, Flue Collector
19	812-0706	Insulation, Upper Burner Rail
20	812-0993	Insulation, Upper Oil Zone
21	812-1029	Insulation, Combustion Chamber Side
22	814-0048SP	Sight Glass
23	816-0057	Gasket, Plenum Chamber
24	816-0558	Insulation, Combustion Chamber, Outer
25	816-0559	Insulation, Upper Front
26	823-0970SP	Plenum, Dual Vat ( <i>use 823-1049 for CE units</i> )( <i>823-2181 for HI50-2's</i> )
27	823-2822	Burner Rail, Left
28	823-2823	Burner Rail, Right
29		Frypot, Dual Vat (shown for assembly reference only)
30	823-3302	Retainer, Lower Front Insulation ( <i>before 09/01 use 823-0983SP</i> )
31	823-3303	Combustion Chamber Outer Front ( <i>before 09/01 use 823-0968SP</i> )
32	824-0865	Retainer, Left Front Seal Insulation
33	824-0866	Retainer, Right Front Seal Insulation
34	900-0914	Retainer, Rear Insulation and Combustion Chamber Back
35	900-1031	Retainer, Sight Glass, ¾-inch
36	900-1049	Retainer, Plenum Chamber Gasket
37	900-1515	Brace, Upper Oil Zone Insulation
38	900-4452	Retainer, Combustion Chamber Side Insulation
39	930-0818	Bracket, Flue to Frypot Connection
40	900-4253	Strip, Fluecap Retainer
41	824-0541	Riser, DV Pot Divider W/A
*	910-2474	Pot-to-Pot Gap Clip
*	813-0156	Plug, ½-inch NPT BM (for blocking unneeded ports)
*	813-0336	Plug, ½-inch SS (for blocking unneeded ports)
*	900-0857	Brace, Frypot to Cabinet

\*Not illustrated.

## 2.15 Gas Supply System Assemblies and Component Parts

### 2.15.1 FM/MJH50 Gas Manifold Assemblies

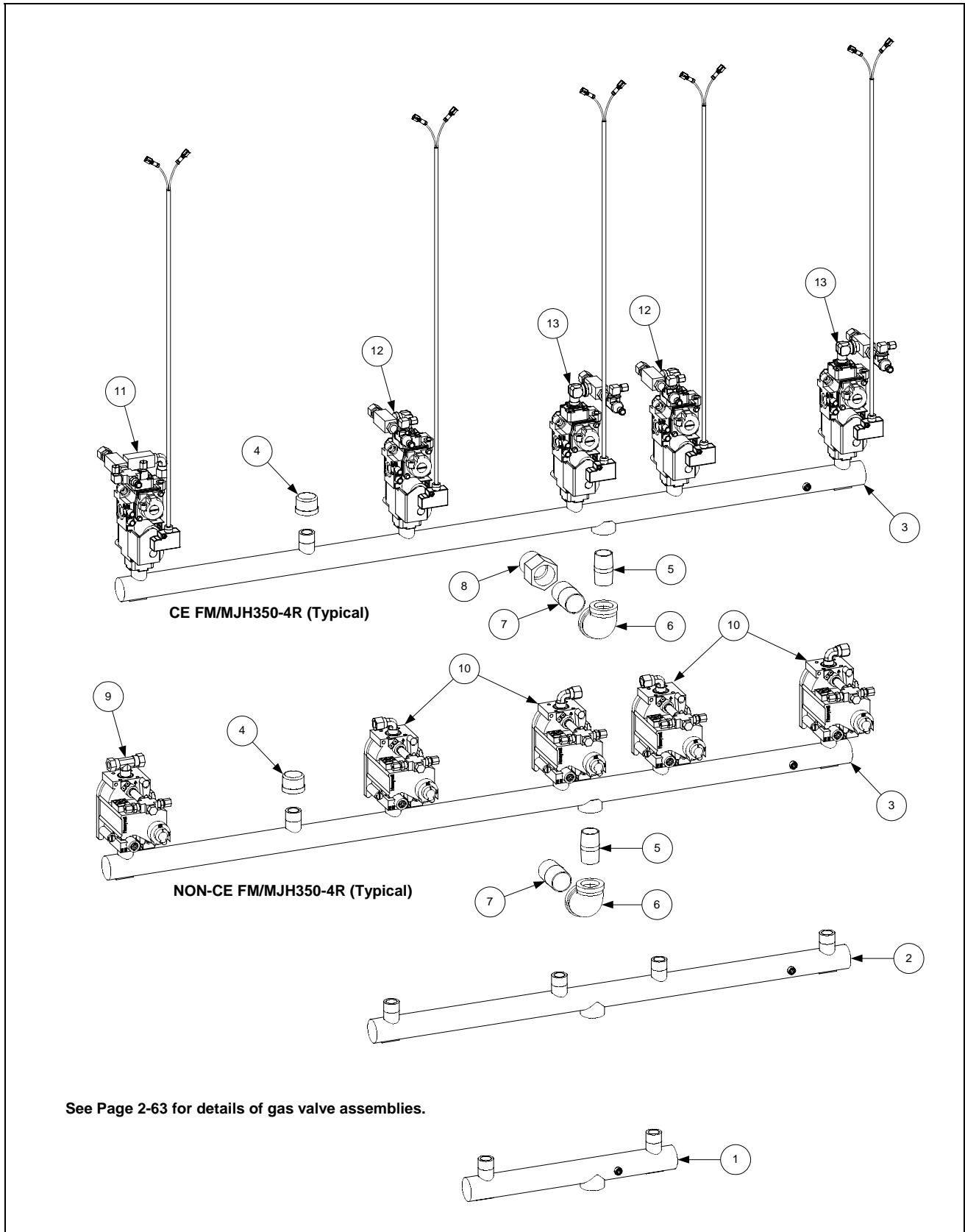

ITEM	PART #	COMPONENT
1	810-0959	FM/MJH150 Gas Manifold
2	810-0661	FM/MJH250 Gas Manifold
3	810-0660	FM/MJH350 Gas Manifold
4	813-0469	Cap, Pipe, ½-inch, BM
5	813-0111	Nipple, ¾-inch x 1¾-inch, BM
6	813-0305	Elbow, 1-inch x ¾-inch, BM
7	813-0138	Nipple, 1-inch x Close, BM
8	813-0505	Adapter, 1-inch NPT x 1-inch BSPT
9		Gas Valve Assembly, Non-CE Full Vat
	806-5304SP	Natural Gas
	806-5305SP	Propane Gas
10		Gas Valve Assembly, Non-CE Dual Vat
	806-5306SP	Natural Gas
	806-5307SP	Propane Gas
11		Gas Valve Assembly, CE Full Vat
	806-7467SP	Natural (G20, G25) Gas
	806-7466SP	Propane (G30, G31) Gas
12		Gas Valve Assembly, CE Dual Vat (Left)
	806-7465SP	Natural (G20, G25) Gas
	806-7464SP	Propane (G30, G31) Gas
13		Gas Valve Assembly, CE Dual Vat (Right)
	806-7463SP	Natural (G20, G25) Gas
	806-7462SP	Propane (G30, G31) Gas
*	810-1306	Gas Valve, Manual ½"
*	810-1307	Gas Valve, Manual ¾"

**NOTE:** Batteries larger than FM/MJH350 use combinations of the above components (e.g., a FM/MJH450 uses one of Item 1 and one of Item 3 plus the appropriate gas valves and connection fittings for the specific configuration).

## 2.15.2 Gas Valves, Gas Lines and Fittings

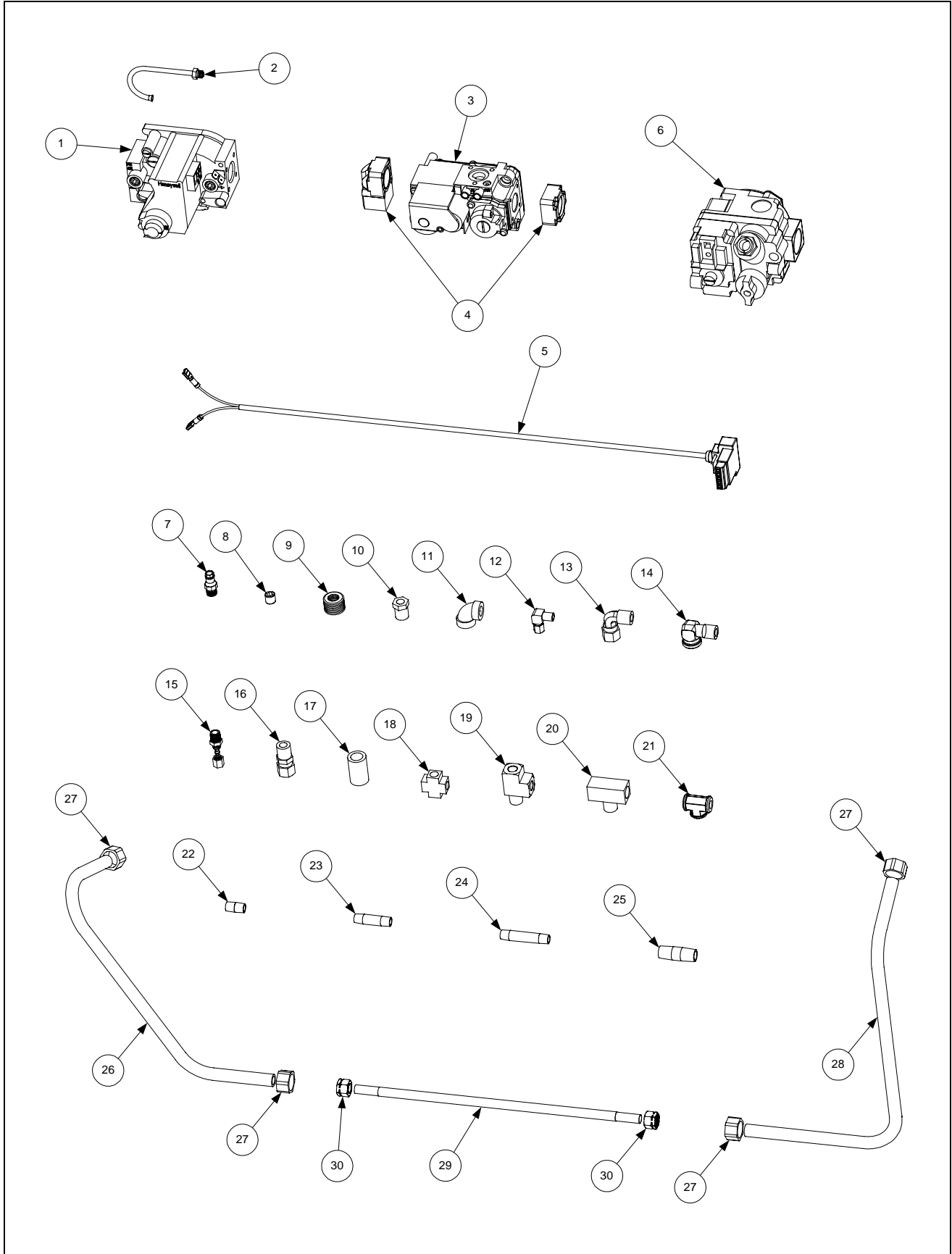

ITEM	PART #	COMPONENT
1		Gas Valve and Bushing, Non-CE
	826-1122	Natural (G20, G25) Gas
	826-1123	Propane (G30, G31) Gas
	826-1576	Gas Valve and Harness CE
2	810-0691	Vent Tube (used with Item 1) (for CE units, use 810-1166)
3	810-1715	Gas Valve, Universal CE (G20/G25/G30/G31) adjustable 2" to 20"
4	810-1041	Accessory Kit (2 straight and 2 elbow flanges, screws, O-rings, LP gas spring)
5	806-9678SP	Plug Assembly, CE Gas Valve (used with Item 3)
6	807-1229	Gas Valve, Manufactured Gas
7	810-1176	Tap, 1/8-inch NPT Pressure
8	813-0411	Plug, 1/8-inch NPT Allen-head Pipe
9	813-0304	Bushing, 1/2-inch to 1/4-inch NPT Reducer
10	810-1006	Bushing, 1/4-inch to 1/8-inch NPT Reducer
11	813-0004	Elbow, 90° x 1/8-inch NPT
12	813-0354	Elbow, 90° x 1/8-inch NPT x 1/8-inch Tube (Brass)
13	813-0302	Elbow, 90° x 3/8-inch Tube x 1/4-inch Male NPT (Brass)
14	813-0502	Elbow, 90° Street x 1/4-inch (Brass)
15	813-0340	Connector, 1/8-inch Tube to 1/8-inch Male NPT (Brass)
*	810-0502	Connector, 1/8-inch Tube to 1/8-inch Male NPT (Brass) (with Item 6 only)
16	810-1025	Connector, 3/8-inch Tube to 1/4-inch Male NPT (Brass)
17	813-0507	Coupling, 1/4-inch NPT (Brass)
18	813-0378	Cross Fitting, 1/2-inch Female NPT (Brass)
19	810-1026	Tee, 1/4-inch NPT Street (Brass)
20	813-0495	Tee, 1/4-inch Male NPT Branch (Brass)
21	813-0377	Tee, 1/8-inch Female NPT (Brass)
22	813-0016	Nipple, 1/8-inch NPT Close
23	813-0315	Nipple, 1/8-inch NPT x 1 1/2-inch
24	813-0405	Nipple, 1/8-inch NPT x 2-inch
25	813-0471	Nipple, 1/4-inch NPT x 1 1/2-inch
26	900-3693	Gas Tube (Left), H50 FV Manufactured Gas (pre-formed)
27	810-0503	Compression Nut (Ferrule), 1/2-inch Manufactured Gas Tube
28	900-3692	Gas Tube (Right), H50 FV Manufactured Gas (pre-formed)
*	900-3691	Gas Tube (Left and Right), H50 DV Manufactured Gas (pre-formed)
29		Flexible Stainless Steel Gas Line (Flexline), 3/8-inch OD
	810-1353	9-inch (22.9 cm) (826-1530 Kit includes 2 of Item 30)
	810-1354	12-inch (30.5 cm) (826-1531 Kit includes 2 of Item 30)
	810-1355	15-inch (38.1 cm) (826-1532 Kit includes 2 of Item 30)
30	810-0494	Compression Nut (Ferrule), 3/8-inch Flexible Gas Line
*		Enrichment Tube, 1/8-inch OD
	811-0752	5 1/2-inch (14 cm)
	811-0756	8 1/2-inch (21.6 cm)
	811-0800	12 1/2-inch (31.8 cm)
	812-0742	18-inch (45.7 cm)
	900-7450	20-inch (51 cm)
	811-0759	Variable Length (sold by the foot)
*	810-1166	Vent Tube CE (used with Item 3)
*	813-0340	Fitting, Enrichment Tube for Gas Valve End
*	810-0502	Fitting, Enrichment Tube for Ignitor Connection

\* Not illustrated.

## 2.16 Probe, Probe Guard and Thermostat

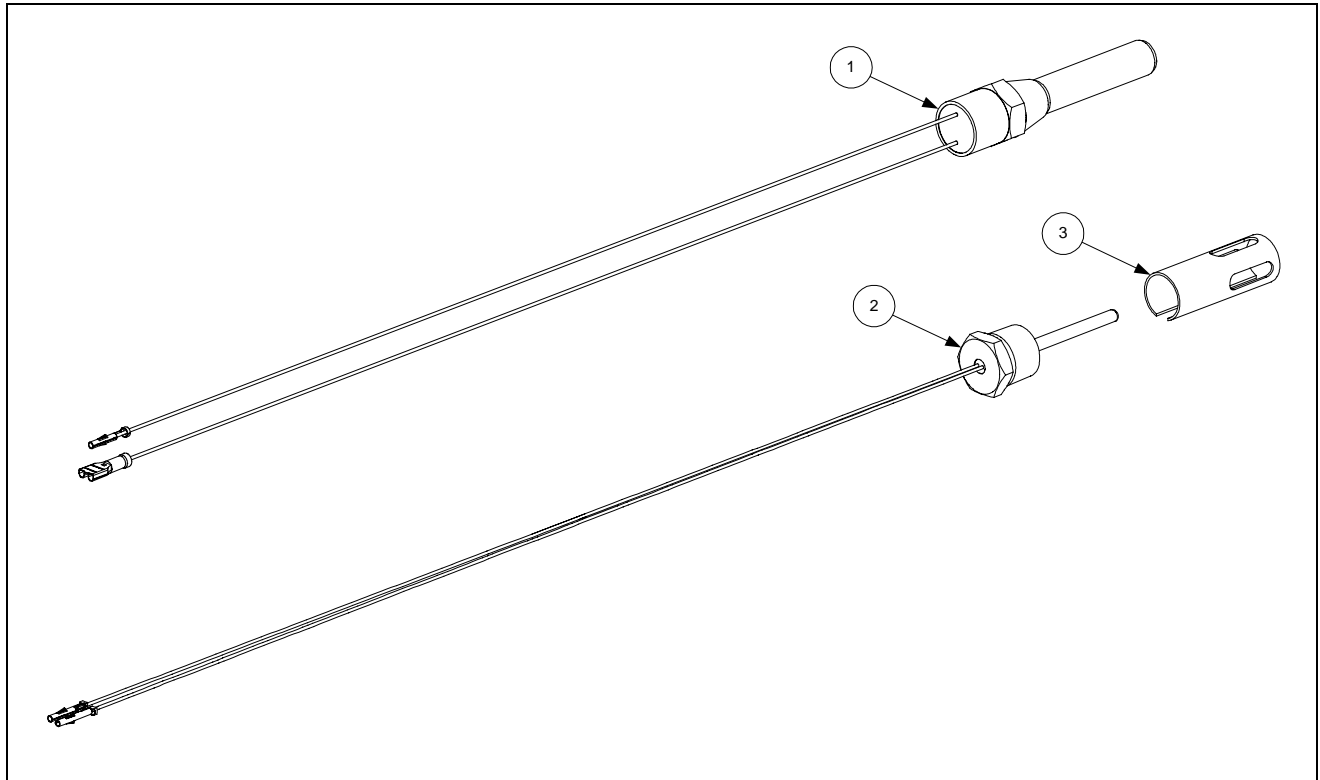

ITEM	PART #	COMPONENT
1	826-1177	High Limit Thermostat (425°F/218°C)
2	806-4206	Temperature Probe Assembly
3	210-0681	Probe Guard (replaced 810-0625)



## 2.18 Relays, Transformers, Wiring Assemblies and Related Parts

### 2.18.1 Filter Box Components

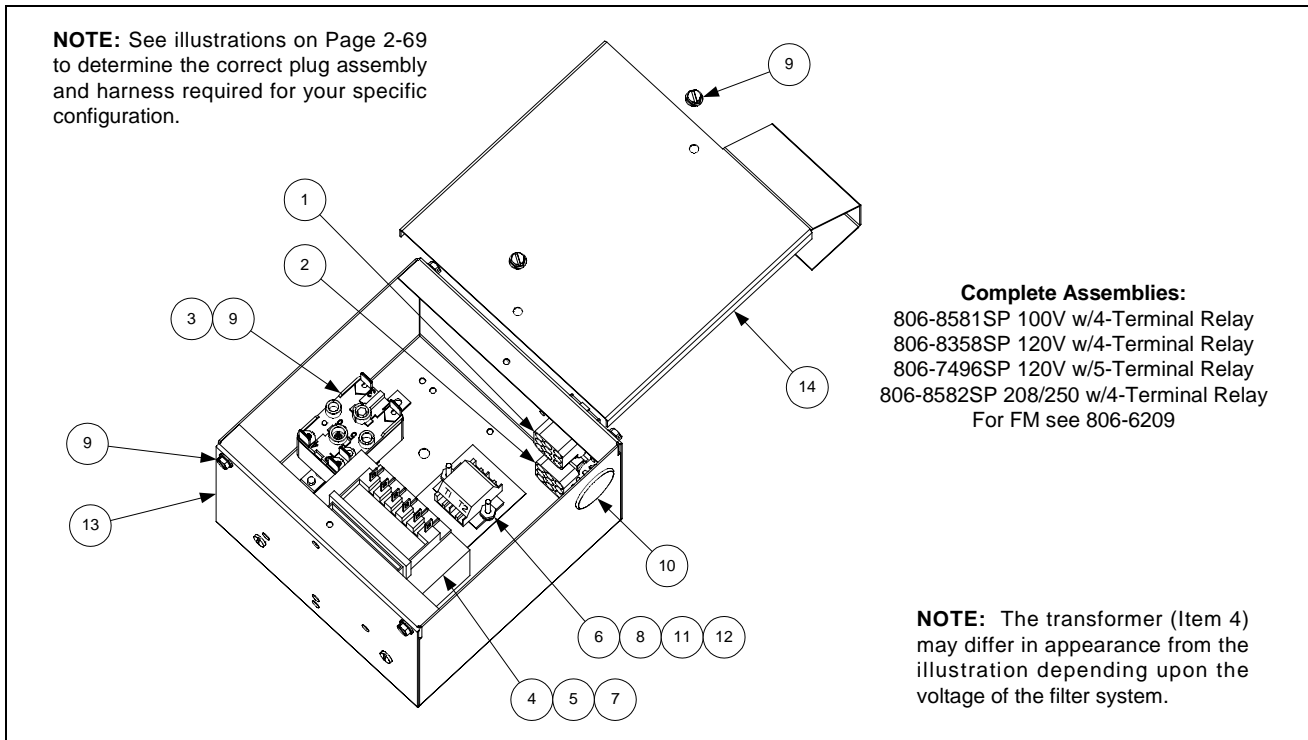

ITEM	PART #	COMPONENT
1		Plug Assembly, Top Position
	806-6725SP	4-Wires w/o keying plug (see illustration on Page 2-69)
	806-8021SP	6-Wires w/keying plug in pin 5 (see illustration on Page 2-69)
2		Plug Assembly, Bottom Position
	806-6719SP	5-Wires w/o keying plug in pin 6 (see illustration on Page 2-69)
	806-7494SP	5-Wires w/keying plug in pin 6 (see illustration on Page 2-69)
3	807-2434	Relay, 5-Terminal Pump Motor (for 4-Terminal, use 807-0012)
4		Transformer
	807-2176	100-120V Primary 12/24V Dual-Tap Secondary 50/60 Hz 50VA
	807-0855	120V Primary 12V Secondary 50/60Hz, 20VA
	807-0800	120V Primary 24V Secondary 50/60 Hz 50VA
	807-1999	202-240V Primary 24V Secondary 50/60 Hz 50VA
5	809-0096	Screw, 6-32 x 5/8-inch Slot Head
6	826-1366	Nut, 4-40 Keps Hex (Pkg. of 25)
7	809-0250	Nut, 6-32 Keps Hex
8	826-1359	Screw, 4-40 x 3/4-inch Slotted Pan Head (Pkg. of 25)
9	809-0360	Screw, #8 x 3/8-inch Slotted Washer Hex Head
10	810-0044	Plug, 5/8-inch
11	810-1164	Terminal Block
12	816-0217	Paper, Insulating
13	900-5250	Box, FP III Filter
14	900-5530	Cover, FP III Filter Box
*	810-1062	Harness, Filter Box

\* Not illustrated

## 2.18.2 Transformer Box Components

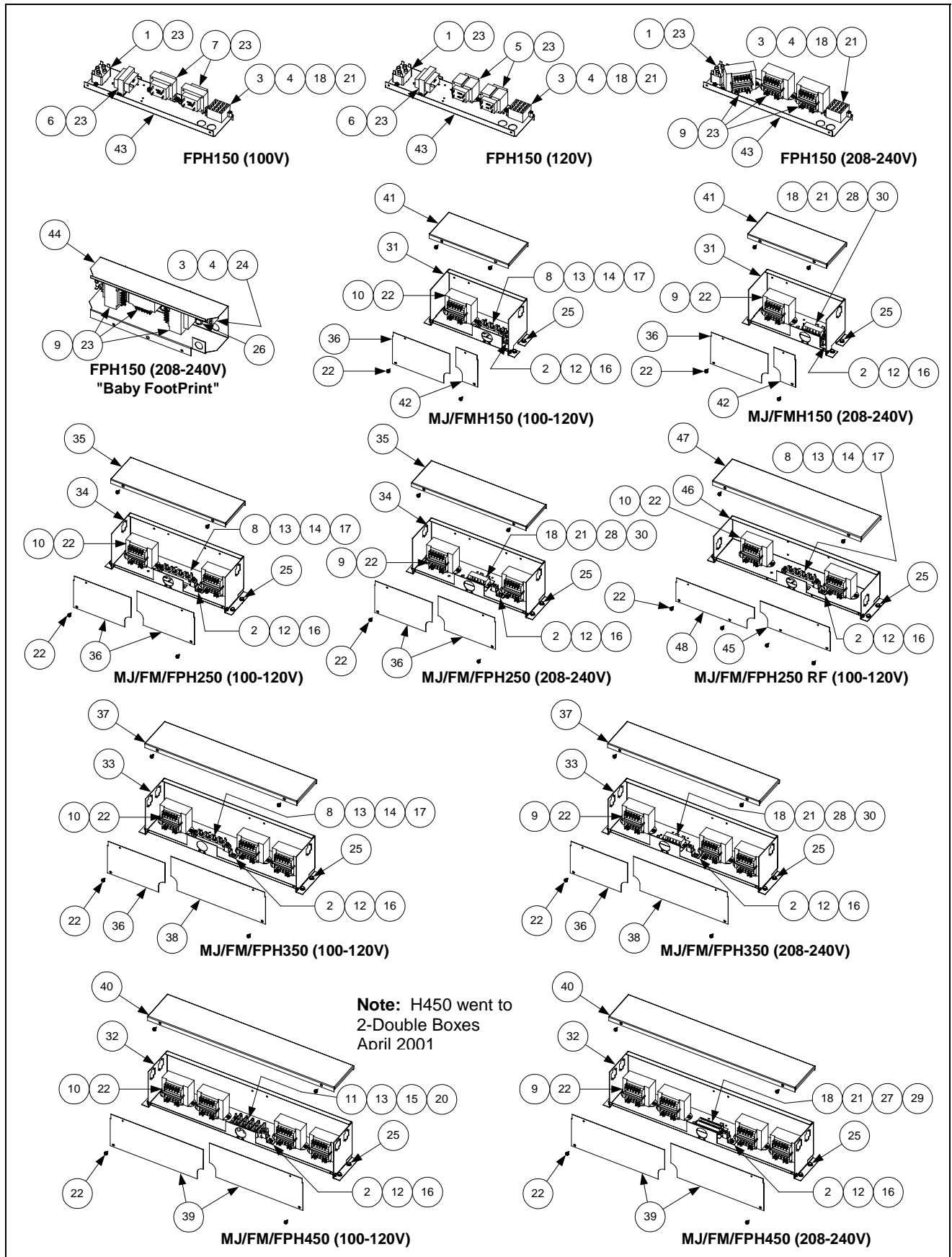

ITEM	PART #	COMPONENT
1	807-0012	Relay, 18 Amp 1/3-HP 24V Coil
2	807-0070	Terminal Lug, Brundy KPA4C
3	807-0255	Terminal Jumper
4	807-0273	Terminal Block, 16-Pin
5	807-0800	Transformer, 120V Primary 24V Secondary 50/60 Hz 50VA
6	807-0855	Transformer, 120V Primary 12V Secondary 50/60 Hz 20VA
7	807-1238	Transformer, 100V Primary 24V Secondary 50/60 Hz 50VA
8	807-1973	Connector, 4-Post Terminal
9	807-1999	Transformer, 202-240V Primary 24V/12V Secondary 50/60 Hz 50VA Dual Tap
*	807-0979	Transformer, 208/240V Primary 12V Secondary 50/60Hz 20VA
*	806-4000	Transformer Assy. 220/240V Primary 12V Secondary 50/60Hz 40VA (German & Dutch) requires fuse 807-1597
*	807-2180	Transformer, 208-240V Primary 24V Secondary 50/60Hz 50VA
*	806-4001SP	Transformer, 220/240V Primary 24V Secondary 50/60Hz 75 VA (German & Dutch) Requires fuse 807-1597
10	807-2176	Transformer, 100-120V Primary 12/24V Dual-Tap Secondary 50/60 Hz 50VA
11	807-2608	Terminal Block, 50A 2-Stud/Pole Post
12	809-0050	Nut, 2-32 Hex
13	809-0052	Nut, 10-24 Hex
14	826-1362	Nut, 1/4-20 Hex (Pkg. of 10)
15	826-1365	Screw, 6-32 x 3/8-inch Slotted Truss Head (Pkg. of 25)
16	826-1363	Screw, 2-32 x 1/2-inch Slotted Truss Head (Pkg. of 25)
17	826-1389	Screw, 1/4-20 x 3/4-inch Hex Head (Pkg. of 10)
18	826-1366	Nut, 4-40 Keps Hex (Pkg. of 25)
19	809-0247	Nut, 2-32 Keps Hex
20	809-0250	Nut, 6-32 Keps Hex
21	826-1359	Screw, 4-40 x 3/4-inch Slotted Pan Head (Pkg. of 25)
22	809-0360	Screw, #8 x 3/8-inch Slotted Hex Washer Head
23	826-1371	Screw, #8 x 1/2-inch Hex Head (Pkg. of 25)
24	809-0362	Screw, #8 x 1- Hex Washer Head
25	826-1374	Screw, #10 x 1/2-inch Hex Washer Head (Pkg. of 25)
26	810-0045	Bushing, .875 Diameter
27	810-1162	Terminal Block, 4 Place
28	810-1163	Terminal Block, 3 Place
29	816-0218	Paper, 4 Place Terminal Block Insulating
30	816-0219	Paper, 3 Place Terminal Block Insulating
31	900-2697	Box, Transformer H150/H152
32	900-2698	Box, Transformer H450/H452
33	900-2699	Box, Transformer H350/H352
34	900-2700	Box, Transformer H250/H252
35	900-2702	Cover, H250/252 Transformer Box Top
36	900-2703	Cover, H50/H52 Transformer Box Front (H150 L, H250 L & R, H350 L)
37	900-2704	Cover, H350/H352 Transformer Box Left Top
38	900-2705	Cover, H350/H352 Transformer Box Right Front
39	900-2706	Cover, H450/H452 Transformer Box Left and Right Front
40	900-2707	Cover, H450/H452 Transformer Box Top
41	900-2708	Cover, H150/H152 Transformer Box Top
42	900-2709	Cover, H150/H152 Transformer Box Right Front
43	900-4555	Bracket, Transformer Mount
44	900-5560	Shield, Component
45	900-5923	Cover, H250/H252 Transformer Box Right Front
46	900-5924	Box, H250/H252 Transformer
47	900-5927	Cover, H250/H252 Transformer Box Top
48	900-5928	Cover, H250/H252 Transformer Box Left Front
*	806-7999SP	FPH150 Basket Lift Wiring Assembly

\* Not illustrated.

## 2.19 Wiring Harnesses, Wiring Assemblies and Plug Assemblies

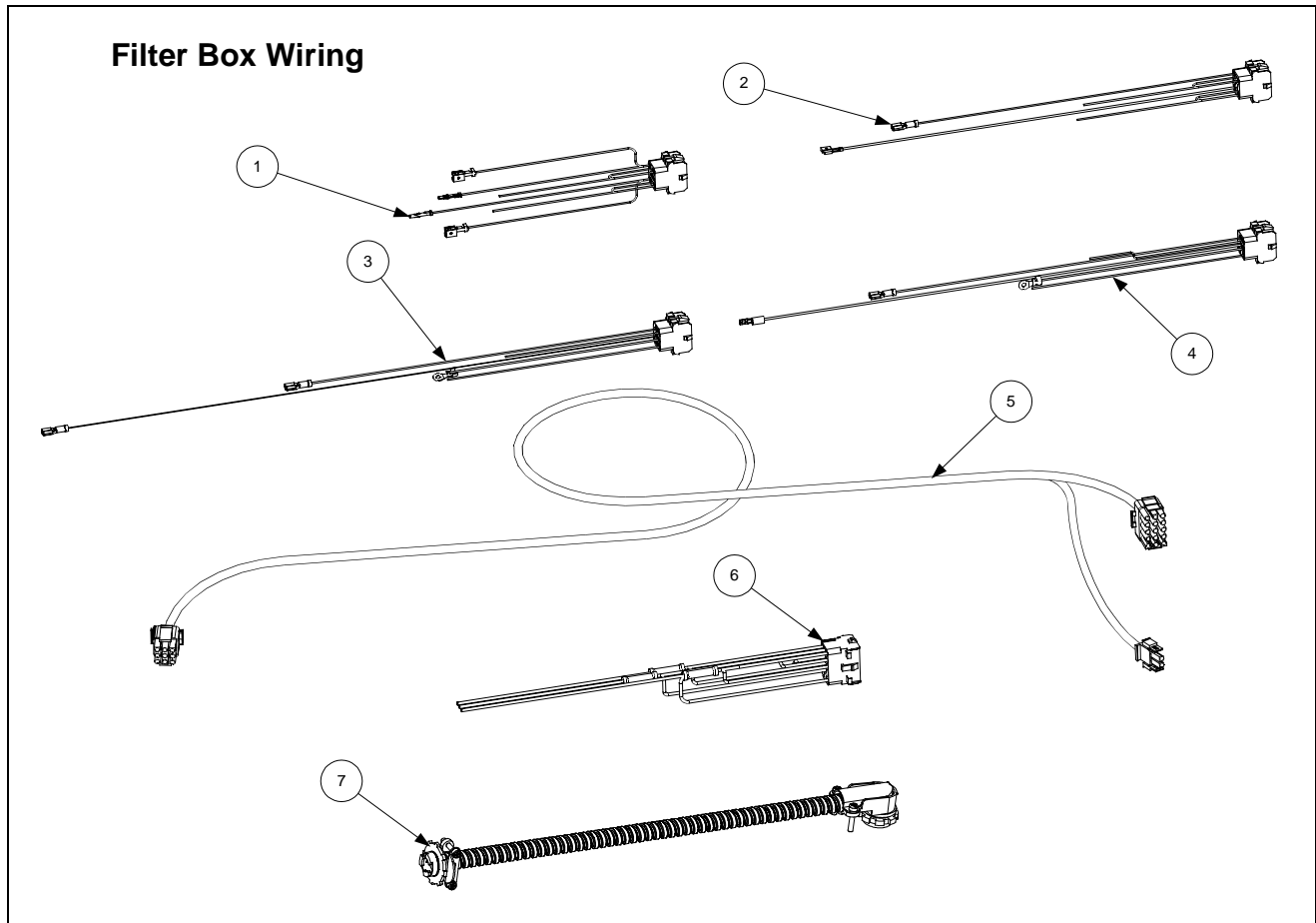

ITEM	PART #	COMPONENT
1	806-8021SP	120V U.S. and 100/120V Non-CE Export Upper 9-Pin Plug Assembly
2	806-7494SP	120V U.S. Lower 9-Pin Plug Assembly (Main)
3	806-6725SP	230V CE Upper 9-Pin Plug Assembly
4	806-6719SP	100/120V Non-CE Export and 230V CE Lower 9-Pin Plug Assembly
5	810-1062	Cable, Filter Box Lower 9-Pin Plug to 807-2000/2001 C2 Connector (FP) w/ BL
*	807-2016	Cable, Filter Box Lower 9-Pin Plug to 807-2000/2001 C2 Connector (FM) Main Wiring Harness
*	807-2000	Cable, 810-1062 C2 Connector to Component Box (units w/Basket Lift)
6	807-2001	Cable, 810-1062 C2 Connector to Component Box (units w/o Basket Lift)
7		Pump Motor to Filter Box Wiring Assembly
	806-6728SP	FootPrint
	806-4347	Filter Magic
*	807-3695	H50 Basket Lift Cable
*	807-0160	12-pin Connector Male FPH150
*	WIR0129SP	FPH150 Rear Ext. Box
*	WIR0233SP	100-250V CE and Non-CE Export Filter Box Internal Wiring Bundle
*	WIR0234SP	120V U.S. Filter Box Internal Wiring Bundle
*	WIR0355SP	FPH150 Rear Ext. Box (Panda Express)

\* Not illustrated.

## Main Wiring Harnesses

U.S. and Non-CE harness (shown) has two unterminated wires.

Unterminated wires.

CE harness has two unterminated wires plus two additional wires with push-on terminals.

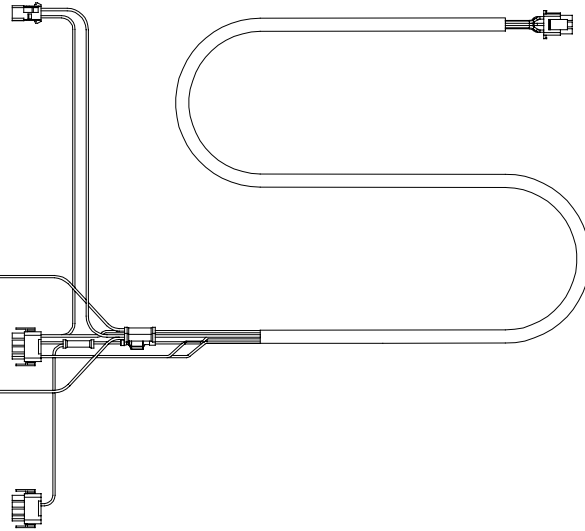

ITEM	PART #	COMPONENT
	807-1978	U.S. and Non-CE Export (before 05/95, use 806-2076SP)
	806-2077SP	U.S. and Non-CE Export (DV before 05/95)
	807-2168	CE Main Wiring Harness
	806-2071	Interface Harness- Computer to Interface Board
	807-2275	Interface Harness- Computer to Interface Board (MFG Gas Only)
	807-2657	Ferrite Collar Bead

## Power Cords

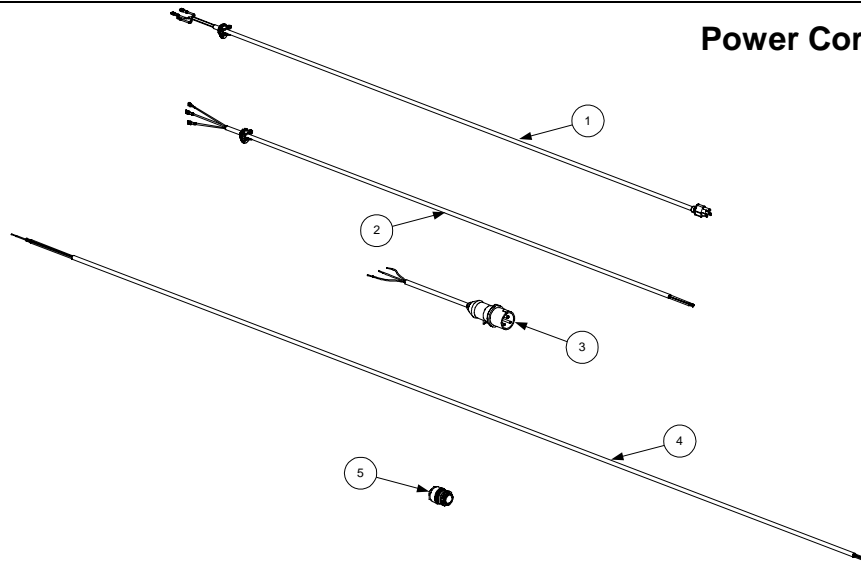

ITEM	PART #	COMPONENT
1	806-5332SP	Power Cord, 120V w/Grounding Plug (w/Push-On Terminals and Clamp)
*	806-7742	Power Cord, 120V w/Grounding Plug (w/Ring Terminals, no Clamp)
*	807-0154	Power Cord, 120V w/Grounding Plug (w/o Terminals or Clamp)
2	806-6229SP	Power Cord, 240V w/o Plug
3	807-1696	Power Cord, CE
4	807-1685	Power Cable, 110-inch, 3-wire, 16-gauge, 450V, 18A
5	807-1560	Strain Relief

# Transformer Box Plug Assemblies

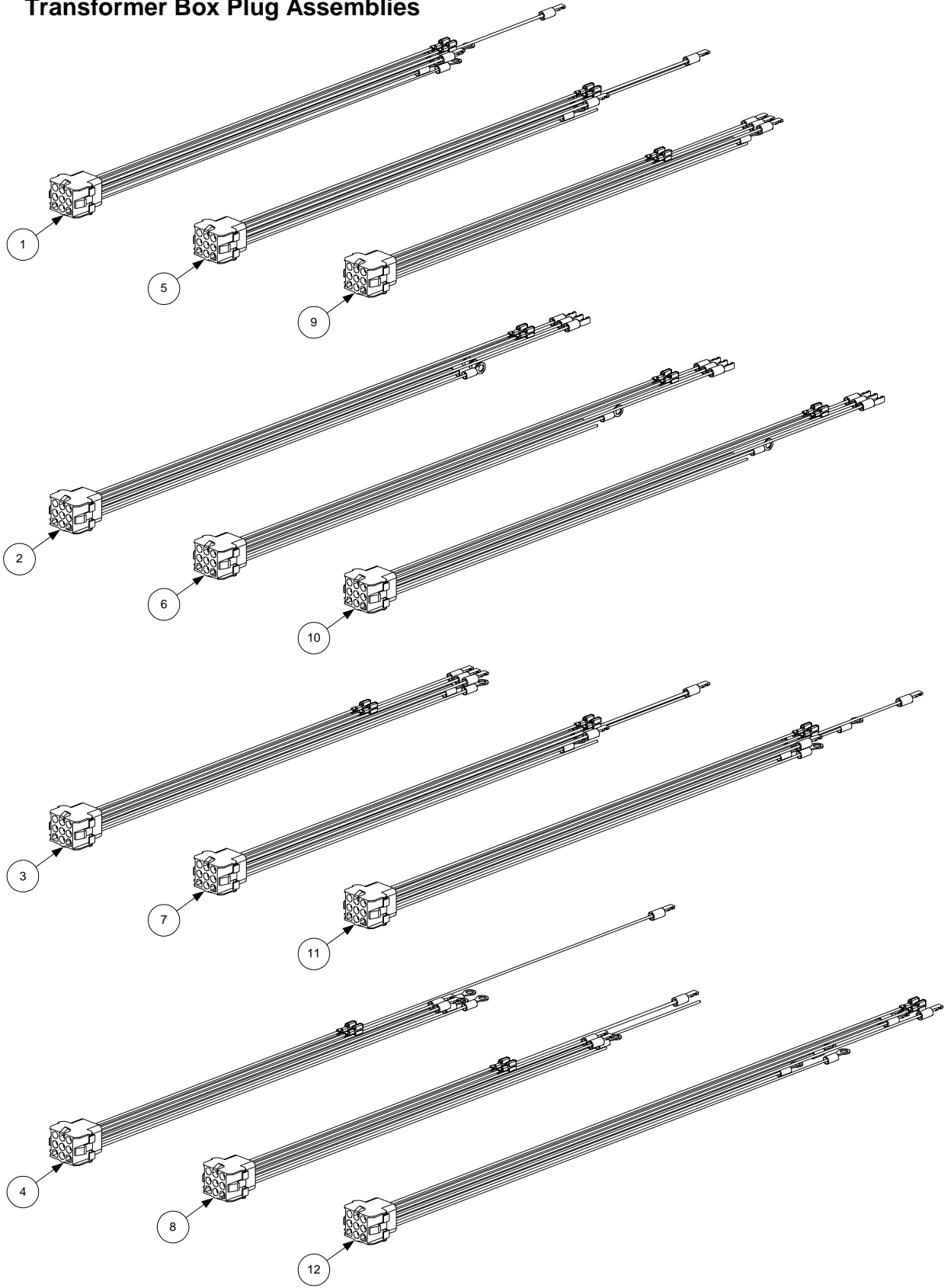

ITEM	PART #	COMPONENT
1	806-6164SP	FMH150, MJ/FM/FPH250-Right, MJ/FM/FPH350/450-Left Front
2	806-6165SP	MJ/FM/FPH250-Left, MJ/FM/FPH350/450-Left Rear
3	806-6166SP	MJ/FM/FPH350-Right, MJ/FM/FPH450-Right Rear
4	806-6167SP	MJ/FM/FPH450-Right Front
5	806-6637	FMH150 CE, MJ/FM/FPH250 CE-Left
6	806-6638	MJ/FM/FPH350 CE-Left Front, MJ/FM/FPH450 CE-Left Rear
7	806-6639	MJ/FM/FPH350 CE-Left Rear, MJ/FM/FPH450 CE-Left Front
8	806-6640	MJ/FM/FPH450 CE-Right Front
9	806-6641	MJ/FM/FPH350 CE-Right, MJ/FM/FPH450 CE-Right Rear
10	806-6642	MJ/FM/FPH250 CE-Right
11	806-8712SP	MJ/FM/FPH250-Left
12	806-8713	MJ/FM/FPH250-Right
*		Transformer Box Wire Bundle
	WIR0110SP	MJ/FMH150, MJ/FM/FPH250
	WIR0111SP	MJ/FM/FPH350
	WIR0112	MJ/FM/FPH450
	WIR0129SP	FPH150
	WIR0149	MJ/FM/FPH250 CE
	WIR0150	MJ/FM/FPH350 CE
	WIR0151	MJ/FM/FPH450 CE
	WIR0152	MJ/FMH150 CE
	WIR0355SP	FPH150 (Panda Express Variant)
	WIR0365	FPH150 CE (Baby FootPrint Variant)
*	807-0156	9-Pin Connector Female

\* Not illustrated.

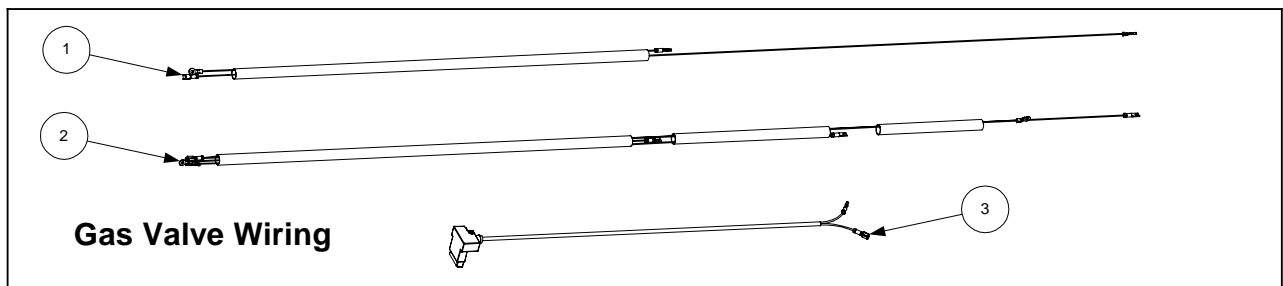

ITEM	PART #	COMPONENT
1	806-3941SP	Harness, Full Vat Gas Valve
2	806-3940SP	Harness, Dual Vat Gas Valve
3	806-9678SP	Plug Assembly, CE Gas Valve

## 2.20 Wiring Connectors and Pin Terminals

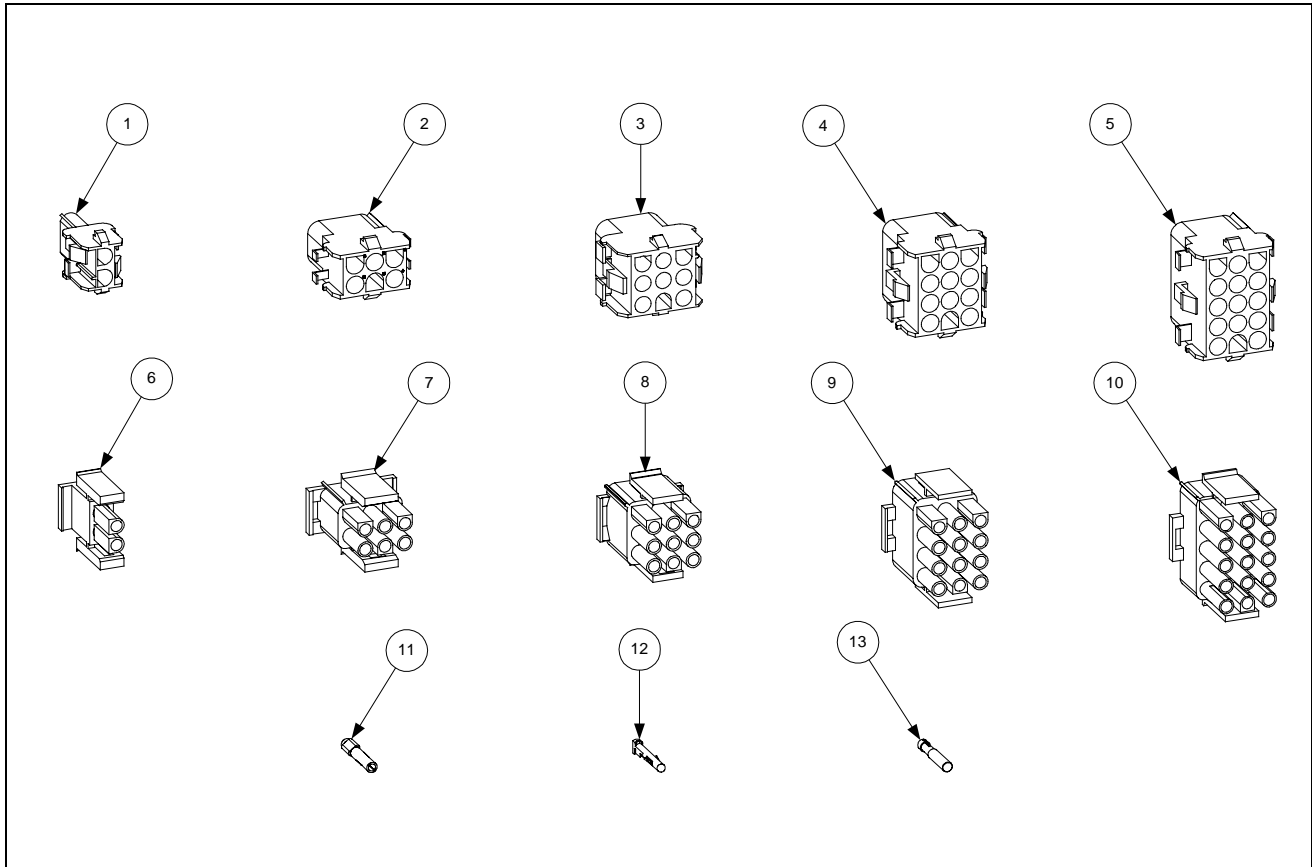

ITEM	PART #	COMPONENT
1	807-1068	2-Pin Female
2	807-0158	6-Pin Female
3	807-0156	9-Pin Female
5	807-0159	12-Pin Female
5	807-0875	15-Pin Female
6	807-1067	2-Pin Male
7	807-0157	6-Pin Male
8	807-0155	9-Pin Male
9	807-0160	12-Pin Male
10	807-0804	15-Pin Male
11	826-1341	Terminal, Female Split Pin (Pkg of 25)
12	826-1342	Terminal, Male Split Pin (Pkg of 25)
13	807-2518	Plug, Mate-N-Lock (Dummy Pin)



**THIS PAGE INTENTIONALLY LEFT BLANK**



**Enodis**<sup>®</sup>  
One Company, Countless Solutions

**Frymaster, L.L.C., 8700 Line Avenue, PO Box 51000, Shreveport, Louisiana 71135-1000**  
**Shipping Address: 8700 Line Avenue, Shreveport, Louisiana 71106**

**TEL 1-318-865-1711    FAX (Parts) 1-318-219-7140    FAX (Tech Support) 1-318-219-7135**

**PRINTED IN THE UNITED STATES**

**SERVICE HOTLINE**  
**1-800-551-8633**

**819-0001**  
**JUNE 2005**