

FUJIFILM

DIGITAL RADIOGRAPHY

FUJIFILM DR

FDR D-EVO
(DR-ID 600)

Operation Manual

6st Edition: October 2010

For Safe Operation

**System
Configuration
(Product Overview)**

Basic Operation

Troubleshooting

**Daily Inspection and
Maintenance**

Appendix

**Maintenance and
Inspection**

This Operation Manual describes details on how to operate the FDR D-EVO and cautions to be observed when operating it. Please read the Operation Manual thoroughly before actually operating the FDR D-EVO along with "DR-ID 300CL Operation Manual" and other manuals for the related products.

After reading this manual, store it nearby the FDR D-EVO so that you can see it whenever necessary.

FUJIFILM Corporation

Introduction

The Wired/Wireless FDR D-EVO (DR-ID 600) flat panel detector system is intended to capture for display radiographic images of human anatomy. It is intended for use in general projection radiographic applications wherever conventional film/screen or CR systems may be used. The FDR D-EVO (DR-ID 600) is not intended for mammography, fluoroscopy, tomography, and angiography applications.

This Operation Manual includes descriptions of matters necessary when using the FDR D-EVO, such as the equipment overview, operation procedures and precautions to observe, as well as daily inspections and maintenance.

Accompanying documents were originally drafted in the English language.

Installation may only be conducted by authorized service personal.



CAUTIONS

1. No part or all of this manual may be reproduced in any form without prior permission.
2. The information contained in this manual may be subject to change without prior notice.
3. FUJIFILM Corporation shall not be liable for malfunctions and damages resulting from installation, relocation, remodeling, maintenance, and repair performed by other than dealers specified by FUJIFILM Corporation.
4. FUJIFILM Corporation shall not be liable for malfunctions and damages of FUJIFILM Corporation products due to products of other manufacturers not supplied by FUJIFILM Corporation.
5. FUJIFILM Corporation shall not be liable for malfunctions and damages resulting from remodeling, maintenance, and repair using repair parts other than those specified by FUJIFILM Corporation.
6. FUJIFILM Corporation shall not be liable for malfunctions and damages resulting from negligence of precautions and operating methods contained in this manual.
7. FUJIFILM Corporation shall not be liable for malfunctions and damages resulting from use under environment conditions outside the range of using conditions for this product such as power supply, installation environment, etc. contained in this manual.
8. FUJIFILM Corporation shall not be liable for malfunctions and damages resulting from natural disasters such as fires, earthquakes, floods, lightning, etc.

This system is classified as a medical device under EC Directive 93/42/EEC.

Caution : Rx Only in the United States (Federal law restricts this device to sale by or on the order of a physician.)

Open-Source Software Used in This Product

This product uses third party's software that is made available as open source software or free software.

For information on open source software used in this product, please see the attached CD. Source codes for certain type of open source software used in this product are available at delivery cost. If you would like to receive such source codes, please contact FUJIFILM dealer or the service representatives at the agency from which you purchased this product. (Please be noted that any inquiries concerning the contents of source codes should be directed to original licensors of open source software.)

Note : FUJIFILM has successfully performed verification and validation testing on all third party software and has confirmed its suitability to be used in this system.

Trademarks

All company names and product names described in this manual are the trademarks or registered trademarks of FUJIFILM Corporation or their respective holders.

Windows Vista is the registered trademark of US Microsoft Corporation in the U.S.A. and other countries.

Windows is the registered trademark of US Microsoft Corporation in the U.S.A. and other countries.

FDR D-EVO System Operation Manuals

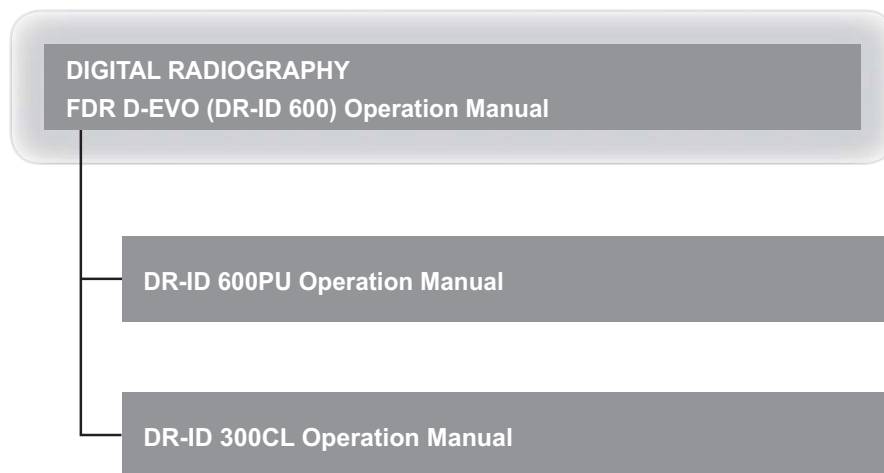

- ❶ See “DR-ID 300CL Operation Manual” along with the manuals for the related products.
- ❷ The DR-ID 600MC runs on a commercially available personal computer. However, operations are not required to use the FDR D-EVO. For operations of a commercially available personal computer, see the operation manual provided by the manufacturer.

Manage and store all the Operation Manuals of the devices constituting the system together as a set.

For the U.S.

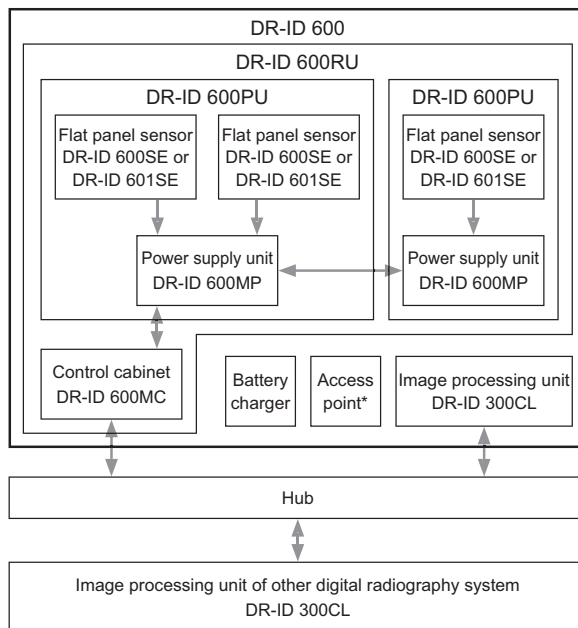

For other countries

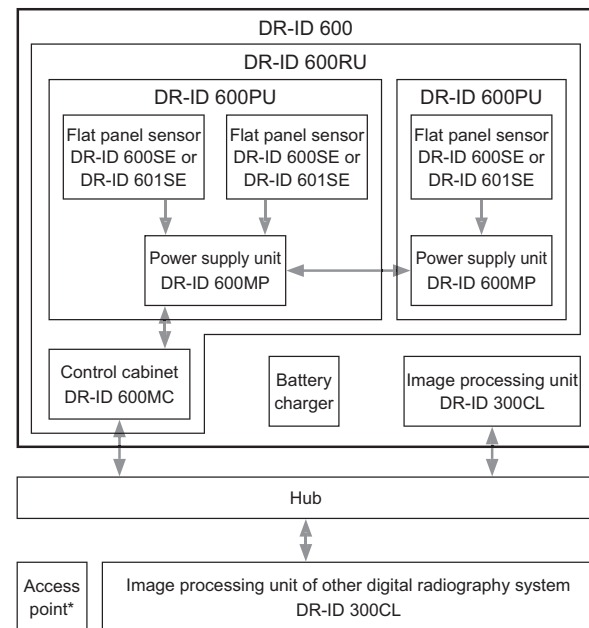

* With regard to the access point, consult our official dealer.

The configuration of the system varies depending on the country.

There are two types of flat panel sensors: DR-ID 601SE (wireless/wired communication mode) and DR-ID 600SE (wired communication mode). Although the contents of this manual are described by taking the example of DR-ID 601SE, the same can also be applied to DR-ID 600SE. With regard to the description specific to DR-ID 601SE or DR-ID 600SE, the product name is specified in the description.

Contents at a Glance

Chapter 1	For Safe Operation This chapter presents Warnings and Cautions we wish you to observe for safe operation of the FDR D-EVO.
Chapter 2	System Configuration (Product Overview) This chapter gives the various unit names and describes their functions and features of the FDR D-EVO.
Chapter 3	Basic Operation This chapter describes start-up, shut-down and other basic operations of the FDR D-EVO.
Chapter 4	Troubleshooting This chapter describes how to troubleshoot in the event of an error on the FDR D-EVO, and provides explanations about a list of error messages each of which appears when an error occurs.
Chapter 5	Daily Inspection and Maintenance This chapter describes daily care and maintenance we wish you to perform so that you can use the FDR D-EVO optimally.
Appendix	Appendix A Specifications Appendix Z Precautions for Exposure Appendix O Use of Optional Items

Maintenance and Inspection

How to Read This Manual

Basic page layout

Please have a good grasp of the basic page configuration of this Operation Manual, as illustrated below, for you to use it more efficiently.

Section title

Shows the title of an operation procedure described in the section.

Lead

Describes information we wish you to know in advance of your operating the system or information that may help you to operate it.

3.2 Starting Up and Shutting Down the System

This section explains how to start up and shut down the system. To start up the system, operations are required on the FDR D-EVO main unit and on the Console. To shut down the entire system, operations are required only on the Console.

3.2.1 Starting Up the System

1 Press the ON side of the main switch of the power supply unit, if its power status LED is not lit.

2 After confirming the following items, press the power switch for the Console to start the initialization process.

- All cables should be connected properly.
- No media should be inserted into the FDD.

The control cabinet starts up automatically.



CAUTIONS

If the power status LED of the power supply unit does not come on after turning on the Console, turn on the control cabinet.

3 Turn on the radiographic examination stand.

4 After displaying the start-up progression status, software version, and initialization progression status, the activation completion screen below will be displayed on the Console.

Activation completion screen of the Console



CAUTIONS

An error occurs if the system is started up immediately after shutdown. To restart the system, make sure that the power status LED of the power supply unit is off, and then press the power switch for the Console.

Operation procedure

Describes an operation procedure according to sequential numbers.

Index

A caption that facilitates you to open a desired [Chapter] quickly.

Displayed screen

A screen that appears during operation.





Page number

Displayed in conjunction with the chapter number.

Marks

Information items to be observed when you are operating this system and the supplementary remarks are described in this manual with the respective marks.

For the safe system operation, be sure to observe *Warning/Caution*.

	WARNING	Indicates hazardous situations that may lead to serious injuries or even death if the precaution is not or cannot be followed.
	CAUTIONS	Indicates hazardous situations that may lead to mild or moderate injury or physical damages if the caution is not or cannot be followed.
		Indicates procedures requiring special attention, instructions that must be followed, supplementary explanations, etc.
	HINT	Shows an item helpful for further effective system operation.
		Shows a more detailed operation method or an item that describes additional information.

Expressions

Messages appear on the display panel and the buttons are shown as below.

- **Buttons (example)**



Select .
The button to operate is shown.

Contents

Introduction.....	iii
FDR D-EVO System Operation Manuals	iv
Contents at a Glance.....	v
How to Read This Manual	vi

Chapter 1 For Safe Operation

1.1	Precautions Before Operating This Equipment.....	1-1
1.2	Precautions to be Observed When Using the Electric Medical Equipment.....	1-2
1.3	Safety	1-3
1.4	Electromagnetic Compatibility (EMC).....	1-8
1.4.1	DR-ID 600PU and DR-ID 300CL	1-8
1.4.2	DR-ID 600MC	1-13
1.5	Precautions in Using the FDR D-EVO.....	1-16
1.5.1	Handling.....	1-16
1.5.2	Before Exposure.....	1-17
1.5.3	During Exposure.....	1-17
1.5.4	During Cleaning.....	1-17
1.5.5	Storage	1-17
1.6	Locations of Labels and Signs	1-18
1.6.1	Locations of Labels.....	1-18
1.6.2	DR-ID 600.....	1-19
1.6.3	DR-ID 600PU.....	1-20
1.6.4	Safety and Other Symbols.....	1-21
1.7	Installation Conditions	1-22
1.7.1	Installation Space When Setting the Control Cabinet in the X-ray Room.....	1-22

Chapter 2 System Configuration (Product Overview)

2.1	FDR D-EVO.....	2-1
2.1.1	System Configuration	2-1
2.1.2	Features of the FDR D-EVO.....	2-2
2.2	Unit Names and the Functions.....	2-3
2.2.1	DR-ID 600.....	2-3
2.3	Console Display Configuration.....	2-5
2.4	Routine Operation Diagram.....	2-6

Chapter 3 Basic Operation

3.1	Preparing the Flat Panel Sensor	3-1
3.1.1	Type of Flat Panel Sensor	3-1
3.1.2	Number of the Connectable Flat Panel Sensors	3-1
3.1.3	Connecting/Disconnecting the Flat Panel Sensor (DR-ID 601SE) Connector.....	3-1
3.1.4	Connecting/Disconnecting the Sensor Cable Relay Connector for the Flat Panel Sensor (DR-ID 600SE)	3-2
3.1.5	Inserting/Removing the Flat Panel Sensor into/from the Radiographic Examination Stand	3-3
3.1.6	Changing the Direction of the Flat Panel Sensor Connector.....	3-4
3.1.7	Charging the Battery Pack (Optional) for the Flat Panel Sensor (DR-ID 601SE)....	3-5
3.1.8	Installing/Removing the Battery Pack (Optional) for the Flat Panel Sensor (DR-ID 601SE).....	3-6

3.2	Starting Up and Shutting Down the System	3-7
3.2.1	Starting Up the System	3-7
3.2.2	Shutting Down the System	3-8
3.3	Routine Operations	3-9
Step 1	Entering the Patient Information	3-10
Step 2	Selecting the Anatomical Region and Exposure/Study Menu.....	3-11
Step 3	X-ray Exposure	3-13
	[1] Positioning the patient	3-13
	[2] X-ray exposure/Image displaying	3-14
	[3] For exposures of the next patient using the same menus.....	3-16

Chapter 4 Troubleshooting

4.1	When a Message Appears on the Console	4-1
	[1] If a warning dialog box appears	4-1
	[2] If a communication error occurs between the Console and the connected DR system	4-1
	[3] If an error occurs on the Console	4-2
	[4] If an error occurs on an output destination device.....	4-2
4.2	How to Cope with an Error... ..	4-3
	[1] When the system hangs up... ..	4-3
	[2] When the Console is turned off due to an electrical outage	4-4
	[3] If a hard disk of the Console is damaged	4-4
	[4] If a white image is displayed after an exposure.....	4-4
	[5] Precautions for operating the system when “Initializing” or “Changing FPD” is displayed in the Console’s operating status display at the time of replacing the flat panel sensor	4-4
	[6] If wireless communication with the flat panel sensor (DR-ID 601SE) is not possible.....	4-4
	[7] If wireless communication mode is disabled when using the flat panel sensor (DR-ID 601SE).....	4-4

Chapter 5 Daily Inspection and Maintenance

5.1	Daily User Inspection and Maintenance.....	5-1
5.1.1	Daily Inspection (DR-ID 600).....	5-1
5.1.2	Periodical Inspection.....	5-2
5.1.3	Effective Period of Use	5-2

Appendix A Specifications

A.1	Specifications	A-1
A.1.1	Processing Capacity (DR-ID 600).....	A-1
A.1.2	Image Output (DR-ID 600).....	A-1
A.1.3	Reduced Equivalent (DR-ID 600)	A-3
A.1.4	Power Supply Conditions.....	A-3
A.1.5	Environmental Conditions.....	A-3
A.2	External View and Weight	A-4
A.2.1	DR-ID 600.....	A-4

Appendix Z Precautions for Exposure

Z1.	Precautions for Exposure in AUTO MODE.....	Z-1
Z.1.1	Radiation Field.....	Z-1
Z.1.2	Depiction of the Cervical Region	Z-2
Z.1.3	Depiction of the HIP JOINT AXL – 2 Menu	Z-2
Z.1.4	EDR Image Data Analysis	Z-3
Z.2	Precautions for Exposure in SEMI-AUTO MODE	Z-4

Z.3	Precautions for Exposure in SEMI-X MODE	Z-5
Z.4	Precautions for Exposure in FIX MODE.....	Z-6
Z.5	Other Precautions	Z-7
Z.5.1	Precautions for Exposure of a Subject in Relatively Large Contrast	Z-7
Z.5.2	Precautions for DR System	Z-7
Z.5.3	Precautions for Assuring the Radiation Field.....	Z-7
Z.5.4	Precautions Related to the X-ray Exposure Time.....	Z-7
Z.5.5	Images Output When the X-ray Shot Switch is Operated Incorrectly	Z-8
Z.5.6	Precautions for Urgent Use	Z-8
Z.5.7	Precautions Related to Continuous Operation	Z-8
Z.5.8	Precautions Related to Grid.....	Z-8

Appendix O Use of Optional Items

O.1	Optional Items	O-1
O.2	Using the Remote Switch	O-2
O.2.1	Remote Switch.....	O-2
O.2.2	Relay Cable	O-2
O.3	Using the SE Storage Case	O-3
O.4	Using the DAP Connector Cable.....	O-4
O.5	Using the Retaining Bracket for MP	O-5

Maintenance and Inspection

Chapter 1 For Safe Operation

1.1 Precautions Before Operating This Equipment

Before using this equipment, please read “Precautions Before Operating This Equipment” carefully so that you can operate it correctly.

Whenever you operate this equipment, be sure to observe those precautions. Failure to do so may cause you to subject to injuries or property damage to occur.

The institution where the equipment is installed is responsible for its use and maintenance.
In addition, this equipment should not be used by persons other than doctors or suitably trained staff.

This system is classified as a medical device under EC Directive 93/42/EEC.
This equipment has been designed on the assumption that the patient would not come into direct contact with it or for operation by appropriately trained operator.

Process waste correctly, as stipulated by local law or any regulations that apply.

Part of the components contains harmful substances which may pollute the ambient environment if disposed carelessly. For details on product disposal, contact a FUJIFILM dealer.

1.2 Precautions to be Observed When Using the Electric Medical Equipment

We ask that you observe these usage precautions and use the equipment correctly.

1. This equipment should be used only by people who have the proper skills.
2. Observe the following precautions when installing the equipment.
 - 2-1. Install the equipment where water will not splash it.
 - 2-2. Install the equipment where it will not be adversely affected by air pressure, temperature, humidity, ventilation, sunlight, dust or the presence of salt, sulfur or like substances in the atmosphere.
 - 2-3. Make sure the equipment will remain in stable condition on a level surface and not be subjected to vibration or shock.
 - 2-4. Do not install the equipment in places where chemicals are stored or gases emitted.
 - 2-5. Make sure that the power frequency, voltage and power consumption are appropriate.
 - 2-6. Connect the ground wire correctly.
3. Observe the following precautions before beginning to use the device.
 - 3-1. Confirm that the ground wire has been completely connected.
 - 3-2. Make sure that all cords have been connected properly and safely.
 - 3-3. Be aware that correct diagnosis can be hindered and danger can result from using different pieces of equipment together.
 - 3-4. Make sure that the battery and power supply are installed properly.
4. Observe the following precautions when using the equipment.
 - 4-1. Make sure not to exceed the time and dose required for diagnosis.
 - 4-2. Always monitor the patient and the equipment for abnormalities.
 - 4-3. Take an appropriate action, such as stopping the equipment after ensuring the patient's safety, if any abnormalities are found in his/her health or in the equipment.
5. Observe the following precautions after using the equipment.
 - 5-1. Using the established procedure, then turn the power off.
 - 5-2. When unplugging cords, do not pull on the body of the cord itself or apply unnecessary force.
 - 5-3. Observe the following precautions when storing the equipment.
 - I Store the equipment where water will not splash it.
 - II Store the equipment where it will not be adversely affected by air pressure, temperature, humidity, ventilation, sunlight, dust or the presence of salt, sulfur or like substances in the atmosphere.
 - III Make sure the equipment will remain in stable condition on a level surface and not be subjected to vibration or shock.
 - IV Do not store the equipment in places where chemicals are stored or gases emitted.
 - 5-4. After using the accessories, recollect them and put them back in order.
 - 5-5. Make sure to clean the equipment for the next use.
6. If there is trouble with the equipment, do not attempt to fix it randomly. Instead, do what is indicated and entrust repairs to a professional.
7. Do not remodel the equipment.
8. Maintenance and Inspection
 - 8-1. Make inspect the equipment and parts periodically.
 - 8-2. If the equipment has not been used for a long time, make sure that it operates normally and safely prior to using it again.
9. Other Items
 - 9-1. When subjecting patients (particularly infants and pregnant women) to radiation, make sure not to exceed the necessary time and dose. Also, ensure that radiation is contained within the exposure plane of the flat panel sensor.
 - 9-2. Follow the Operation Manual and operate the equipment correctly.

1.3 Safety

Before using the FDR D-EVO, read this section thoroughly to ensure that you use the product properly.

Electric Shock Warnings and Cautions



WARNING

The power supply to the FDR D-EVO is AC100 to 240V.

To avoid electric shocks, users should always take the following precautions:

- Never open any covers of the equipment.
- Install the equipment in a location where it will not be exposed to water.
- Check that the equipment is securely earthed.
- Check that all of the cords and cables are completely and securely connected.
- Keep the image processing unit and the control cabinet out of reach of patients.



WARNING

Do not touch the patient's body while touching the control cabinet. Otherwise, the patient may receive an electric shock.



WARNING

Do not use a multiple tap connector or extension cable for powering the devices constituting the system. Otherwise, fire or electric shock may occur due to the electrical load exceeding the allowable limit.



WARNING

Observe the following precautions when using the cables.

- Turn off each unit before connecting/disconnecting the cable.
Do not touch the plug and connector with wet hands. Otherwise, electric shock may result, causing death or severe injury.
- Hold the plug or connector when removing the cable.
Pulling the cable or carrying by holding it may damage the cable, causing fire or electric shock.
- Do not damage or remodel the cable.
Do not place a heavy object on the cable or lay it under the flat panel sensor. Do not step on, pull, forcibly bend, or bundle the cable. Otherwise, fire or electric shock may result.
- Do not use the flat panel sensor for the radiographic examination stand if its cable becomes overloaded. Otherwise, the cable may be damaged, causing fire or electric shock.



WARNING

Do not turn on the system with dew condensation on the flat panel sensor. Otherwise, fire or electric shock may result.



WARNING

Do not use the equipment in a location where metal particles could come into the equipment. This may cause an electric shock.

 **WARNING**

Do not disassemble or remodel the equipment. Otherwise, fire or electric shock may result. Keep away from the parts inside the product, which may cause electric shock. If you touch them accidentally, death or severe injury may result.

 **WARNING**

Do not hit or drop the equipment or subject it to severe shock. Otherwise, the equipment may be damaged. If the damaged equipment is used, fire or electric shock may result.

 **WARNING**

Before using the flat panel sensor (DR-ID 601SE), make sure that the battery cover or battery pack is attached. If not attached, an electric shock may result.

 **CAUTIONS**

As the cables of the equipment are long, be careful not to entangle the cables during use. Also, be careful not to trip over the cables. Falls could result in injury.

 **CAUTIONS**

Follow the specified procedure when turning off the equipment. Otherwise, the flat panel sensor could be damaged by thermal shock.

 **CAUTIONS**

Do not store magnetic media near the DR system and control cabinet. Otherwise, magnetism generated by the equipment may cause the data to be lost.

 **CAUTIONS**

Keep the equipment away from patient's body fluids, chemicals, water, etc. Otherwise, it may become damaged, causing fire or electric shock. If necessary, protect the flat panel sensor by covering it with a disposable bag.

Explosion Warnings

 **WARNING**

Because this equipment is not explosion-proof, do not use combustible and explosive gases near the equipment.

 **WARNING**

Flammable gasses may stay in the room after disinfection. Ventilate the room well before powering on the system following disinfection.

Warnings for Abnormalities



WARNING

If any of the following occurs, immediately turn off the power of each unit, unplug the power cable from the outlet, and then contact a FUJIFILM dealer.

- When smoke, strange odor, or abnormal sound is present.
- When a foreign object (such as a metal object) or liquid enters the product.
- When the equipment is dropped or hit and is damaged.

Installation Precautions



CAUTIONS

Do not install the system in a location with the following conditions.

- Where the temperature changes sharply.
- Close to heat sources such as a heater.
- Where the system may be exposed to water due to water leakage or ingress.
- Where corrosive gas may be generated.
- Where there is excessive dust.
- Where the system is subject to frequent or excessive vibration/shock.
- Where the system is exposed to direct sunlight.
- Where there is no ventilator.



CAUTIONS

For veterinary or mobile applications, please contact a certified FUJIFILM service representative.



CAUTIONS

Use the system indoor in wireless communication mode. For details, contact a FUJIFILM dealer.

Connection Instructions



WARNING

Make sure that the devices to be connected to the equipment are authorized for connection.

System Isolation Instructions



WARNING

To ensure complete system isolation, never install any unauthorized accessories or other such items.

When it is necessary to install authorized accessories or optional items, contact a FUJIFILM dealer.

**WARNING**

Keep equipment other than those used for patients out of their reach to ensure appropriate system isolation.

**WARNING**

Do not move the Console from where it is installed.

Software Precautions

**CAUTIONS**

Do not install additional software to the system. Do not uninstall any of the software preinstalled in the system.

The system is preinstalled with the appropriate software. If other software is installed or if the existing software is uninstalled, various operational errors may result.

Disinfection Instructions

**WARNING**

Confirm that the respiratory density of disinfectant including solvent is under legal regulation. Certain disinfectants may damage health. When using a disinfectant, follow instructions supplied by the manufacturers.

**WARNING**

Do not use the following disinfectants or sterilizers at the time of disinfection. Quality, performance and safety of the equipment cannot be assured.

- Chloric disinfectant which is strongly corrosive to metals and rubber parts.
- Disinfectant whose uses on metals, plastics, and coating are forbidden according to the instructions supplied with the disinfectant.
- Formalin gas and disinfectant sprays that may get inside the equipment.
- Ultraviolet sterilizers

Disinfectant ethanol is recommended for disinfection. Carefully read the instructions and cautions supplied with the disinfectant before use.

**CAUTIONS**

Clean the sensor unit of the flat panel sensor with ethanol for disinfection, etc. for each patient to prevent infection.

Precautions for Charging the Battery



CAUTIONS

Observe the following precautions when charging the battery pack (optional) using the battery charger (optional).

- Do not use the battery pack (125N100050) or battery charger in combination with any battery pack or battery charger (including the AC adapter) other than those recommended by FUJIFILM Corporation.
- Do not disassemble or convert the battery pack or battery charger.
- If the battery pack or battery charger becomes faulty, consult our official dealer.
- Do not cover the holes in the battery charger with foreign matter.
- Avoid the accumulation of dust on the battery charger.
- Insert the battery pack into the battery charger securely.
- If the insertion direction or position of the battery pack is incorrect, the battery is not charged properly.
- When inserting the battery pack, prevent foreign matter from getting into the battery charger.
- While charging the battery, do not allow the battery pack or battery charger get wet or dusty.
- Do not step on the AC adapter of the battery charger. Also, be careful not to trip over the power cable.
- Do not subject the battery and battery charger to severe shock (by dropping them, etc.).

Battery Pack (Optional) Precautions



CAUTIONS

Observe the following precautions when using the battery pack (optional).

- When storing the battery pack for a long period, charge the battery fully, remove it from the flat panel sensor and then store it in a cool and dark place. Recharge the stored battery every six months or every year. Otherwise a decrease in battery capacity or other problems may result.
- Do not leave the removed battery pack in the car or other places exposed to high temperature. The battery pack may ignite, resulting in fire.
- When disposing of the battery pack, consult our official dealer.

Other Cautions



CAUTIONS

Install the system in accordance with what is provided by IEC60601-1-1. Contact a FUJIFILM dealer for installation and relocation (except the flat panel sensor) of the system.



CAUTIONS

Do not hit or drop the equipment. Otherwise, injury or damage to images, etc. may result.



CAUTIONS

Be sure to inspect the system periodically.

To assure optimum performance of the equipment, it is necessary to systematically perform maintenance and inspection. For information on maintenance and inspection, contact a FUJIFILM dealer.

1.4 Electromagnetic Compatibility (EMC)

1.4.1 DR-ID 600PU and DR-ID 300CL

This equipment has been tested and found to comply with the limits for medical devices to the IEC 60601-1-2:2001+A1:2004 (EN60601-1-2:2001+A1:2006), Medical Device Directive 93/42/EEC.

These limits are designed to provide reasonable protection against harmful interference in a typical medical installation.

This equipment generates, uses and can radiate radio frequency energy and, if not installed and used in accordance with the instructions, may cause harmful interference to other devices in the vicinity.

However, there is no guarantee that interference will not occur in a particular installation.

If this equipment does cause harmful interference to other devices, which can be determined by tuning the equipment off and on, the user is encouraged to try to correct the interference by one or more of the following measures:

- Reorient or relocate the receiving device.
- Increase the separation between the equipment.
- Connect the equipment into an outlet on a circuit different from that to which the other device(s) are connected.

If the problem cannot be solved with the above measures, stop using this equipment and consult the manufacturer or our official dealer for help.



WARNING

- **Do not place devices generating electromagnetic wave near this equipment.**
- **If a device(s) other than those specified is connected, predetermined EMC performance cannot be guaranteed.**

Further information for IEC 60601-1-2 (EN60601-1-2)

1. Medical electrical equipment needs special precautions regarding EMC and needs to be installed and put into service according to the EMC information provided in the accompanying documents.
2. Portable and mobile RF communications equipment can affect medical electrical equipment.
3. Information regarding the cable affecting EMC is as follows.

Name	Connected Device	Maximum Length	General Specification
Network Cable	Between the DR-ID 600PU and the DR-ID 600MC	30m	Cat5e or more, UTP type and straight cable
	Between the DR-ID 600MC and the DR-ID 300CL	100m	
Power Cable	DR-ID 600PU	3m	Use a hospital grade power cable. (for North America)
			A non-hospital grade power cable can be used. (for other countries)
	DR-ID 300CL	Depends on the cable length of a personal computer.	

4. The use of accessories, transducers and cables other than those specified, with the exception of transducers and cables sold by FUJIFILM Corporation as replacement parts for internal components, may result in increased emissions or decreased immunity of the DR-ID 600PU and the DR-ID 300CL.
5. The DR-ID 600PU and the DR-ID 300CL should not be used adjacent to or stacked with other equipment.
If adjacent or stacked use is necessary, the DR-ID 600PU and the DR-ID 300CL should be observed to verify normal operation in the configuration in which it will be used.
6. Basic performance of the equipment and the system
After image data are acquired from the DR-ID 600PU, data correction is performed by the control cabinet (DR-ID 600MC), and the image is saved in and displayed on the image processing unit (DR-ID 300CL).
7. Test items (Tables 1 to 4)

Table 1

Guidance and manufacturer's declaration - electromagnetic emissions			
The DR-ID 600PU and the DR-ID 300CL are intended for use in the electromagnetic environment specified below. The customer or the user of the DR-ID 600PU and the DR-ID 300CL should assure that they are used in such an environment.			
Emissions test	Compliance		Electromagnetic environment - guidance
RF emissions CISPR 11	Group 1		The DR-ID 600PU and the DR-ID 300CL use RF energy only for their internal function. Therefore, their RF emissions are very low and are not likely to cause any interference in nearby electronic equipment.
RF emissions CISPR 11	Class A		The DR-ID 600PU and the DR-ID 300CL are suitable for use in all establishments other than domestic and those directly connected to the public low-voltage power supply network that supplies buildings used for domestic purposes.
Harmonic emissions IEC61000-3-2	Complies	DR-ID 600PU: Class A	
		DR-ID 300CL: Class D	
Voltage fluctuations/ flicker emissions IEC61000-3-3	Complies		

Table 2

Guidance and manufacturer's declaration - electromagnetic immunity			
The DR-ID 600PU and the DR-ID 300CL are intended for use in the electromagnetic environment specified below. The customer or the user of the DR-ID 600PU and the DR-ID 300CL should assure that they are used in such an environment.			
Immunity test	IEC 60601 test level	Compliance level	Electromagnetic environment - guidance
Electrostatic discharge (ESD) IEC61000-4-2	±6kV contact ±8kV air	±6kV contact ±8kV air	Floors should be wood, concrete or ceramic tile. If floors are covered with synthetic material, the relative humidity should be at least 30%.
Electrical fast transient/burst IEC61000-4-4	±2kV for power supply lines ±1kV for input/output lines	±2kV for power supply lines ±1kV for input/output lines	Mains power quality should be that of a typical commercial or hospital environment.
Surge IEC61000-4-5	±1kV differential mode ±2kV common mode	±1kV differential mode ±2kV common mode	Mains power quality should be that of a typical commercial or hospital environment.
Voltage dips, short interruptions and voltage variations on power supply input lines IEC61000-4-11	<5% U_T (>95% dip in U_T) for 0.5 cycle 40% U_T (60% dip in U_T) for 5 cycles 70% U_T (30% dip in U_T) for 25 cycles <5% U_T (>95% dip in U_T) for 5 s	<5% U_T (>95% dip in U_T) for 0.5 cycle 40% U_T (60% dip in U_T) for 5 cycles 70% U_T (30% dip in U_T) for 25 cycles <5% U_T (>95% dip in U_T) for 5 s	Mains power quality should be that of a typical commercial or hospital environment. If the user of the DR-ID 600PU and the DR-ID 300CL requires continued operation during power mains interruptions, it is recommended that the DR-ID 600PU and the DR-ID 300CL be powered from an uninterruptible power supply or a battery.
Power frequency (50/60Hz) magnetic field IEC61000-4-8	3 A/m	3 A/m	Power frequency magnetic fields should be at levels characteristic of a typical location in a typical commercial or hospital environment.
NOTE: U_T is the a.c. mains voltage prior to application of the test level.			

Table 3

Guidance and manufacturer's declaration - electromagnetic immunity			
The DR-ID 600PU and the DR-ID 300CL are intended for use in the electromagnetic environment specified below. The customer or the user of the DR-ID 600PU and the DR-ID 300CL should assure that they are used in such an environment.			
Immunity test	IEC 60601 test level	Compliance level	Electromagnetic environment - guidance
Conducted RF IEC61000-4-6	3 Vrms 150 kHz to 80 MHz	3 Vrms	Portable and mobile RF communications equipment should be used no closer to any part of the DR-ID 600PU and the DR-ID 300CL, including cables, than the recommended separation distance calculated from the equation applicable to the frequency of the transmitter.
Radiated RF IEC61000-4-3	3 V/m 80 MHz to 2.5 GHz	3 V/m	<p>Recommended separation distance</p> $d = 1.2\sqrt{P}$ $d = 1.2\sqrt{P} \quad 80 \text{ MHz to } 800 \text{ MHz}$ $d = 2.3\sqrt{P} \quad 800 \text{ MHz to } 2.5 \text{ GHz}$ <p>where P is the maximum output power rating of the transmitter in watts (W) according to the transmitter manufacturer and d is the recommended separation distance in metres (m).</p> <p>Field strengths from fixed RF transmitters, as determined by an electromagnetic site survey,^a should be less than the compliance level in each frequency range.^b</p> <p>Interference may occur in the vicinity of equipment marked with the following symbol:</p> 
NOTE 1: At 80 MHz and 800 MHz, the higher frequency range applies.			
NOTE 2: These guidelines may not apply in all situations. Electromagnetic propagation is affected by absorption and reflection from structures, objects and people.			
<p>a Field strength from fixed transmitters, such as base stations for radio (cellular/cordless) telephones and land mobile radios, amateur radio, AM and FM radio broadcast and TV broadcast cannot be predicted theoretically with accuracy. To assess the electromagnetic environment due to fixed RF transmitters, an electromagnetic site survey should be considered. If the measured field strength in the location in which the DR-ID 600PU and the DR-ID 300CL are used exceeds the applicable RF compliance, the DR-ID 600PU and the DR-ID 300CL should be observed to verify normal operation. If abnormal performance is observed, additional measures may be necessary, such as reorienting or relocating the DR-ID 600PU and the DR-ID 300CL.</p> <p>b Over the frequency range 150 kHz to 80 MHz, field strength should be less than 3 V/m.</p>			

Table 4

Recommended separation distances between Portable and mobile RF communications equipment and the DR-ID 600PU and the DR-ID 300CL			
<p>The DR-ID 600PU and the DR-ID 300CL are intended for use in the electromagnetic environment in which radiated RF disturbances are controlled. The customer or the user of the DR-ID 600PU and the DR-ID 300CL can help prevent electromagnetic interference by maintaining a minimum distance between portable and mobile RF communications equipment (transmitters) and the DR-ID 600PU and the DR-ID 300CL as recommended below, according to the maximum output power of the communications equipment.</p>			
Rated maximum output power of transmitter W	Separation distance according to frequency of transmitter m		
	150 kHz to 80 MHz $d = 1.2\sqrt{P}$	80 MHz to 800 MHz $d = 1.2\sqrt{P}$	800 MHz to 2.5 GHz $d = 2.3\sqrt{P}$
0.01	0.12	0.12	0.23
0.1	0.38	0.38	0.73
1	1.2	1.2	2.3
10	3.8	3.8	7.3
100	12	12	23
<p>For transmitters rated at a maximum output power not listed above, the recommended separation distance d in metres (m) can be estimated using the equation applicable to the frequency of the transmitter, where P is the maximum output power rating of the transmitter in watts (W) according to the transmitter manufacturer.</p>			
<p>NOTE 1: At 80 MHz and 800 MHz, the separation distance for the higher frequency range applies. NOTE 2: These guidelines may not apply in all situations. Electromagnetic propagation is affected by absorption and reflection from structures, objects and people.</p>			

1.4.2 DR-ID 600MC

This equipment has been tested and found to comply with the international standard for medical devices below, according to the requirement of the IEC 60601-1-2:2001+A1:2004/EN 60601-1-2:2001+A1:2006.

EMC Standard : CISPR 22/EN 55022
CISPR 24/EN 55024
EN61000-3-2/IEC61000-3-2
EN61000-3-3/IEC61000-3-3

This does not guarantee that there is no harmful electromagnetic interference under any installation environment.

This equipment can generate, use and radiate radio frequency energy. If the equipment is not installed and used in accordance with the instructions, or if peripheral devices that are not complied with the EMC standard, harmful interference may be generated under a particular environment causing malfunction of the equipment and other devices.

If this equipment causes harmful interference to other devices, or if this equipment is affected by interference from other devices, the user is encouraged to try to correct the interference by one or more of the following measures:

- Reorient or relocate the receiving device.
- Increase the separation between the equipment.
- Connect the equipment into an outlet on a circuit different from that to which the other device(s) are connected.

If the problem cannot be solved with the above measures, stop using this equipment and consult the manufacturer or our official dealer for help.



WARNING

Do not place devices generating electromagnetic wave near this equipment.

Further information for CISPR 22 / EN55022 and CISPR 24 / EN55024

1. Medical electrical equipment needs special precautions regarding EMC and needs to be installed and put into service according to the EMC information provided in the accompanying documents.
2. Portable and mobile RF communications equipment can affect medical electrical equipment.
3. Information regarding the cable affecting EMC is as follows.

Name	Connected Device	Maximum Length	General Specification
Network Cable	Between the DR-ID 600PU and the DR-ID 600MC	30m	Cat5e or more, UTP type and straight cable
	Between the DR-ID 600MC and the DR-ID 300CL	100m	
Power Cable	DR-ID 600MC	Depends on the cable length of a personal computer.	

4. The use of accessories, transducers and cables other than those specified, with the exception of transducers and cables sold by FUJIFILM Corporation as replacement parts for internal components, may result in increased emissions or decreased immunity of the DR-ID 600MC.
5. The DR-ID 600MC should not be used adjacent to or stacked with other equipment.
If adjacent or stacked use is necessary, the DR-ID 600MC should be observed to verify normal operation in the configuration in which it will be used.
6. Basic performance of the equipment and the system
After image data are acquired from the DR-ID 600PU, data correction is performed by the control cabinet (DR-ID 600MC), and the image is saved in and displayed on the image processing unit (DR-ID 300CL).
7. Test items (Tables 1 to 3)

Table 1

Guidance and manufacturer's declaration - electromagnetic emissions	
The DR-ID 600MC is intended for use in the electromagnetic environment specified below. The customer or the user of the DR-ID 600MC should assure that it is used in such an environment.	
Emissions test	Compliance
Noise terminal voltage CISPR 22 EN55022	Class A
Electric field noise strength CISPR 22 EN55022	Class A
Harmonic emissions EN61000-3-2 IEC61000-3-2	Class D
Voltage fluctuations/flicker emissions EN61000-3-3 IEC61000-3-3	Complies

Table 2

Guidance and manufacturer's declaration - electromagnetic immunity		
The DR-ID 600MC is intended for use in the electromagnetic environment specified below. The customer or the user of the DR-ID 600MC should assure that it is used in such an environment.		
Immunity test	EN/IEC test	Compliance level
Electrostatic discharge (ESD) EN61000-4-2 IEC61000-4-2	±4kV contact ±8kV air	±4kV contact ±8kV air
Electrical fast transient/burst EN61000-4-4 IEC61000-4-4	±1kV for power supply lines ±0.5kV for input/output lines	±1kV for power supply lines ±0.5kV for input/output lines
Surge EN61000-4-5 IEC61000-4-5	±1.0kV differential mode ±2.0kV common mode	±1.0kV differential mode ±2.0kV common mode
Voltage dips, short interruptions and voltage variations on power supply input lines EN61000-4-11 IEC61000-4-11	<5% U_T (>95% dip in U_T) for 0.5 cycle 70% U_T (30% dip in U_T) for 25 cycles <5% U_T (>95% dip in U_T) for 250 cycles	<5% U_T (>95% dip in U_T) for 0.5 cycle 70% U_T (30% dip in U_T) for 25 cycles <5% U_T (>95% dip in U_T) for 250 cycles
Power frequency (50/60Hz) magnetic field EN61000-4-8 IEC61000-4-8	1 A/m	1 A/m
NOTE: U_T is the a.c. mains voltage prior to application of the test level.		

Table 3

Guidance and manufacturer's declaration - electromagnetic immunity		
The DR-ID 600MC is intended for use in the electromagnetic environment specified below. The customer or the user of the DR-ID 600MC should assure that it is used in such an environment.		
Immunity test	EN/IEC test	Compliance level
Conducted RF EN61000-4-6 IEC61000-4-6	3 Vrms 150 kHz to 80 MHz	3 Vrms
Radiated RF EN61000-4-3 IEC61000-4-3	3 V/m 80 MHz to 1 GHz	3 V/m

1.5 Precautions in Using the FDR D-EVO

This section describes the precautions in using the FDR D-EVO.

1.5.1 Handling

Handle the flat panel sensor carefully since it is manufactured with precision.

If the flat panel sensor is hit or dropped or is subject to severe shock, it may be damaged.

If the front and rear of the flat panel sensor are subject to impact by a projection, it may be damaged.

The flat panel sensor is equipped with a shock sensor that detects a severe impact. For details, see “■ DR-ID 600PU” (page 2-3).



CAUTIONS

If the shock sensor lights red, contact a FUJIFILM dealer.

Do not pull the cable of the flat panel sensor (Wired communication mode).

Also, do not pull the flat panel sensor with something caught by the cable.

Make sure that the cable is not trapped under the wheels of a stretcher or wheelchair.

Otherwise, the cable will be damaged, causing electric shock or fire.

When carrying the flat panel sensor (Wired communication mode), do not drag the sensor cable relay connector on the floor or ground. Make also sure that no one or object comes into contact with the flat panel sensor. It is recommended to hold the connector when carrying the flat panel sensor.

Unless these cautions are observed, the flat panel sensor may be caught by an object, personal injury may result, or properties or the connector may be damaged.

Do not hold the flat panel sensor in one hand when carrying it. Hold it in both the hands or under the arm.

If any of the screw caps on the flat panel sensor comes off, attach a spare cap. Otherwise, artifacts may appear in the image due to static electricity.

To ensure optimal image quality, it is recommended that you do not use the flat panel sensor near devices (motor, transformer, switching supply, etc.) that generate electromagnetic noise.

To ensure optimal image quality, it is recommended that you do not place the cables (power cable, communication cable, etc.) of the equipment near devices (motor, transformer, switching supply, etc.) that generate electromagnetic noise and their cables.

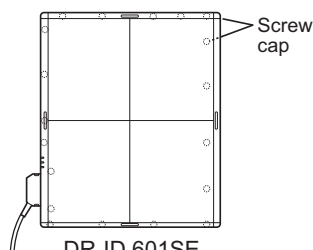
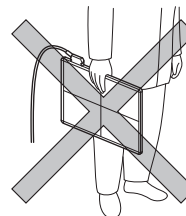
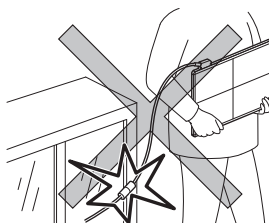
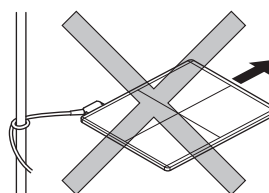
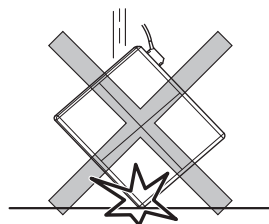

DR-ID 601SE

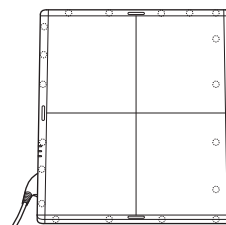

DR-ID 600SE

1.5.2 Before Exposure

The use of an air-conditioner may dramatically changes the temperature of the room where the system is installed. This may cause dew condensation on the system, resulting in quality problems. When an air-conditioner is used, change the temperature gradually to avoid temperature variation in order not to cause dew condensation.

If an exposure is made with the front and rear of the flat panel sensor facing the other way round, re-exposure and electric parts may be damaged.

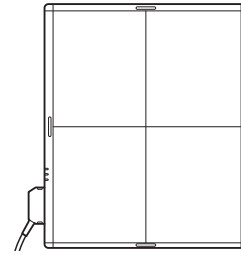

Exposure plane of the flat panel sensor

Do not use the flat panel sensor for the radiographic examination stand equipped with an automatic loading function.

1.5.3 During Exposure

Before making an exposure, make sure that exposure conditions most appropriate for this system are set.

Do not apply an excessive force to the exposure plane.
The sensor inside the flat panel sensor may be damaged.

<Load restriction>

Entire surface load : 125kg

Local load : DR-ID 600SE : 60kg / ø40mm
DR-ID 601SE : 60kg / ø40mm

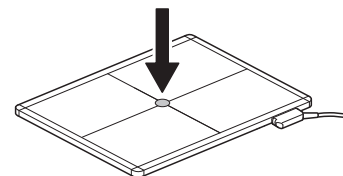
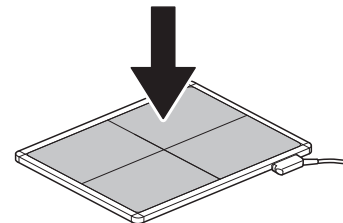

Use the flat panel sensor on a flat floor or platform.
When an excessive force is applied to the unit when it is tilted, the sensor inside the flat panel sensor may be damaged.

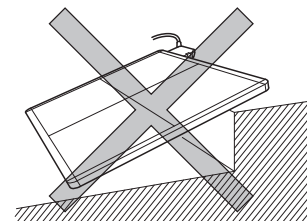

1.5.4 During Cleaning

To clean the outer surfaces, use commercially available ethanol papers for disinfection or a cleaning cloth tightly wrung out of ethanol (or diluted neutral detergent).



CAUTIONS

- Do not use an excessive amount of ethanol (or neutral detergent), as doing so may allow the liquid to enter from the gap on the outer surfaces, resulting in the damage to the flat panel sensor, or cause the labels to come off.
- Do not use a solvent such as thinner or benzene, as it corrodes the outer surfaces.

1.5.5 Storage

When the flat panel sensor is not in use, store the device in a place where it does not fall or drop.

1.6 Locations of Labels and Signs

Locations of labels and signs affixed to the FDR D-EVO, and the relevant safety signs are shown below.

1.6.1 Locations of Labels

For Safe Operation

Flat panel sensor (DR-ID 601SE)

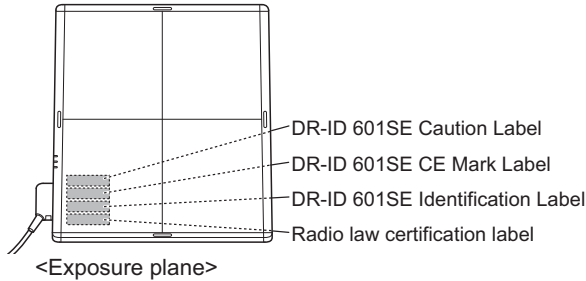

Flat panel sensor (DR-ID 600SE)

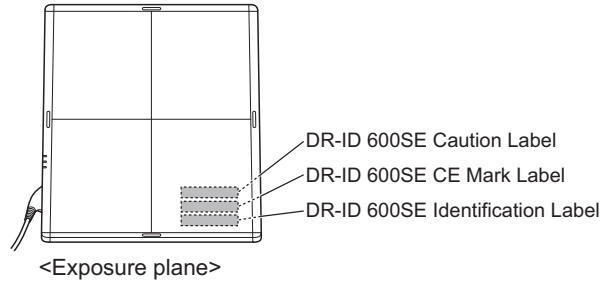

Control cabinet (DR-ID 600MC)

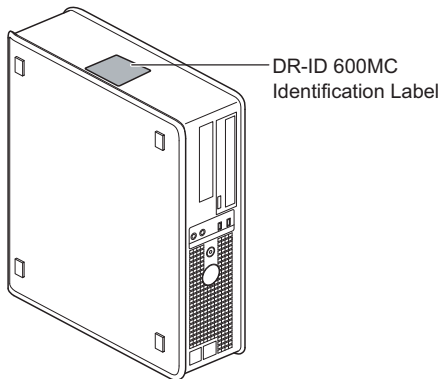

Power supply unit (DR-ID 600MP)

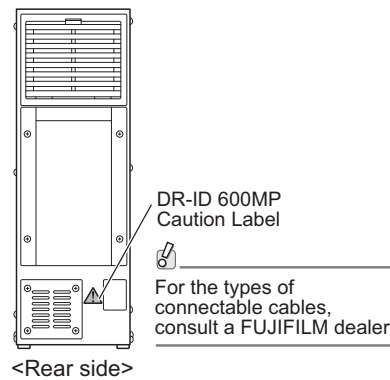
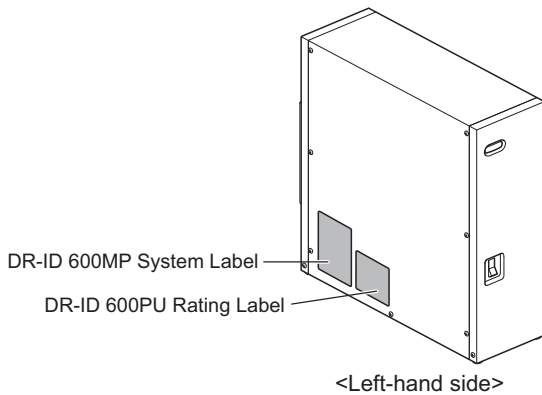

Battery charger (optional)

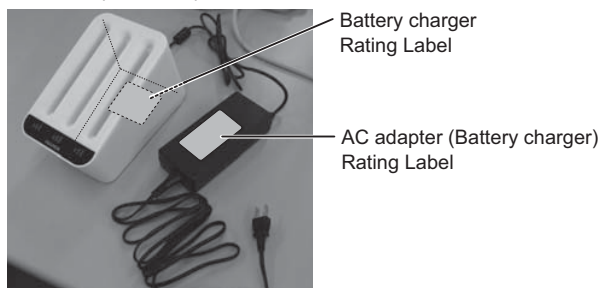

Battery pack (optional)

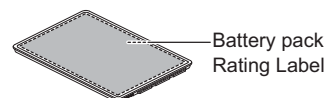

1.6.2 DR-ID 600



DR-ID 601SE CE Mark Label

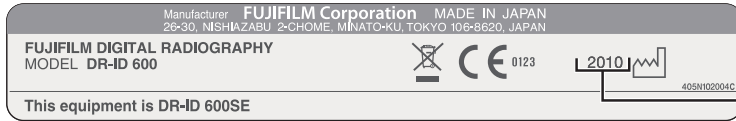

Sample year of manufacture

DR-ID 600SE CE Mark Label

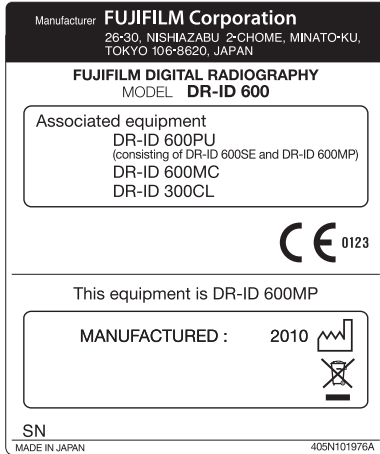

DR-ID 600MP System Label

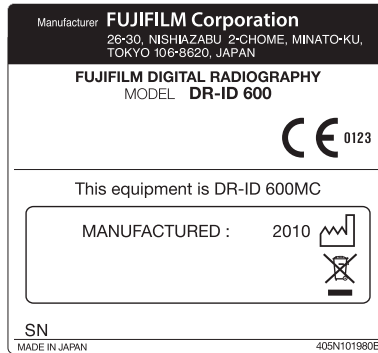

DR-ID 600MC Identification Label

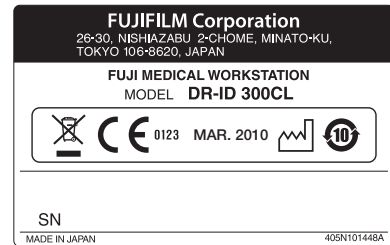

DR-ID 300CL Identification Label

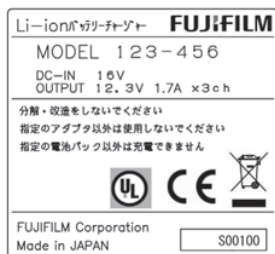

Battery charger Rating Label

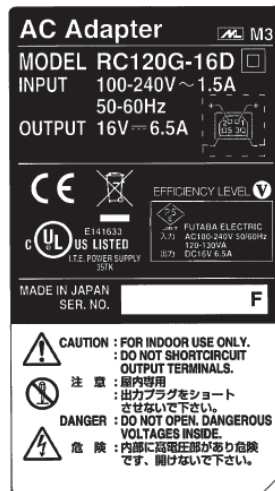

AC adapter (Battery charger)
Rating Label

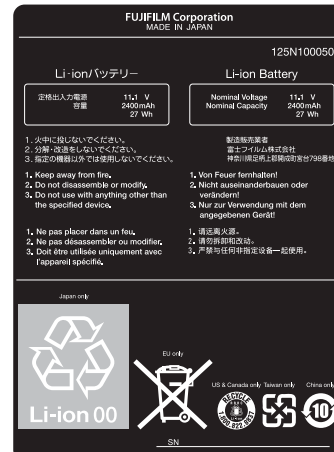

Battery pack Rating Label

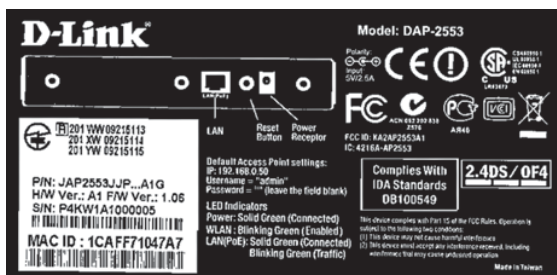

Access point Rating Label*



AC adapter (Access point) Rating Label*

* The access point model is subject to change.

1.6.3 DR-ID 600PU

DR-ID 601SE Identification Label



DR-ID 600SE Identification Label



DR-ID 601SE Caution Label

Radio law certification label



DR-ID 600SE Caution Label

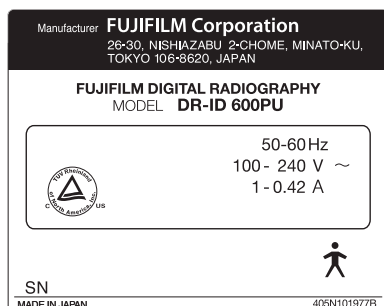

















DR-ID 600PU Rating Label



DR-ID 600MP Caution Label

1.6.4 Safety and Other Symbols

The following safety symbols are used in the labels or on its body.

Symbol	Description
	This symbol indicates compliance of the equipment with Directive 93/42/EEC.
	Caution (See "1.6.1 Locations of Labels" (page 1-17).)
	OFF (To indicate disconnection from the mains, at least for mains switches or their positions, and all those cases where safety is involved.)
	ON (To indicate connection to the mains, at least for mains switches or their positions, and all those cases where safety is involved.)
	Protective earth (ground)
	Alternating current
	This symbol indicates that the equipment is a Type B Applied Part.
	Ready (To indicate the machine is ready for operation.)
	Electric energy
	General mandatory action sign
	Stand-by
	<p>This symbol indicates that this product is not to be disposed of with your household waste, according to the WEEE Directive (2002/96/EC) and your national law. This product should be handed over to a designated collection point.</p> <p>Improper handling of this type of waste could have a possible negative impact on the environment and human health due to potentially hazardous substances that are generally associated with EEE.</p> <p>At the same time, your cooperation in the correct disposal of this product will contribute to the effective usage of natural resources.</p> <p>For more information about waste, please contact FUJIFILM dealers.</p>
	Year of manufacture
	Environmentally Friendly Use Period (EFUP)
	Caution for local load (See "1.5.3 During Exposure" (page 1-16).)
	Entire surface load

1.7 Installation Conditions

1.7.1 Installation Space When Setting the Control Cabinet in the X-ray Room

In case that the control cabinet is installed in the X-ray room, ensure a certain distance between the control cabinet and the upright-type or bed-type radiographic examination stand. See the figure below for reference.

For the products that can be installed in patient environment, see “2.1.1 System Configuration” (page 2-1).



CAUTIONS

Do not install the power supply unit, control cabinet, image processing unit, Battery charger(optional) and Access point in an area of the X-ray room, where the user can easily trip over. Falls could result in injury.

■ Upright type

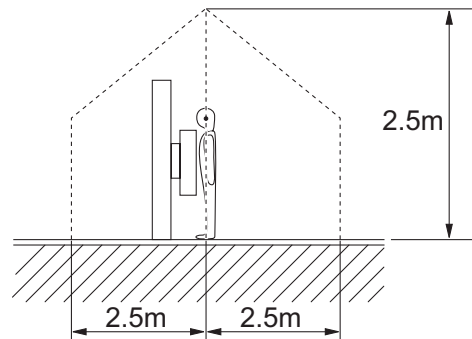
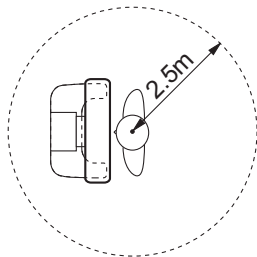

■ Bed type

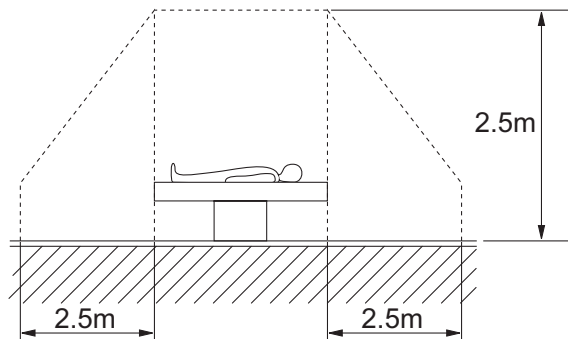
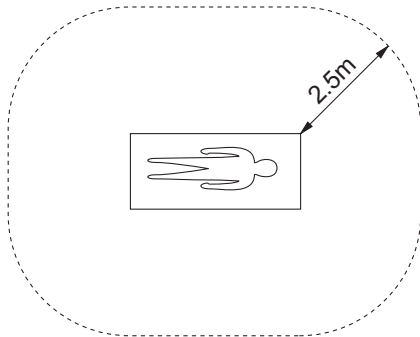

Chapter 2 System Configuration (Product Overview)

2.1 FDR D-EVO

2.1.1 System Configuration

For the U.S.

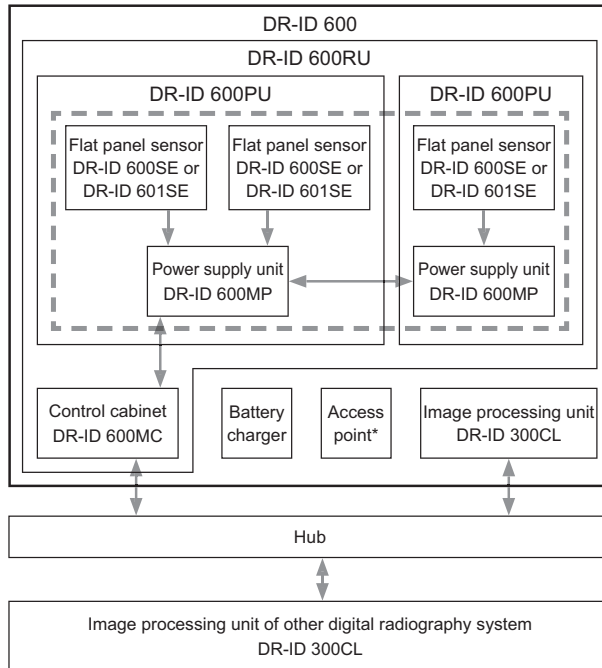

For other countries

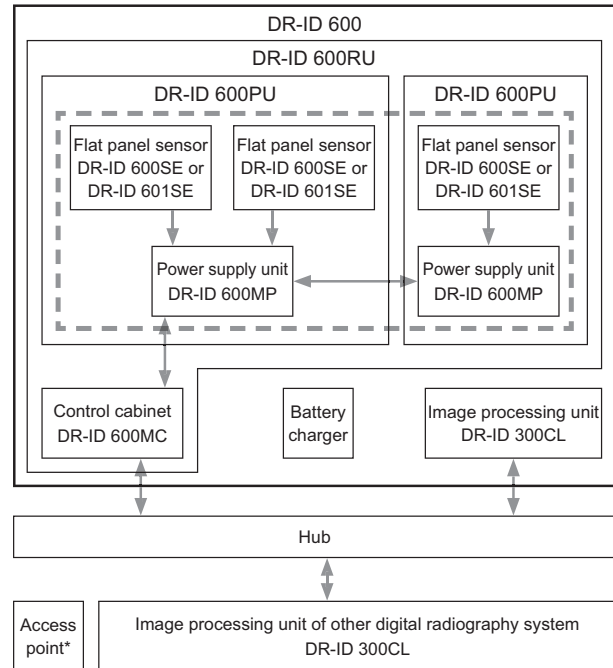

- The products in [] can be installed in patient environment.
- The FDR D-EVO consists of the DR-ID 600RU and the image processing unit DR-ID 300CL.
- An access point is used only in wireless communication mode.
- * The configuration of the system varies depending on the country.

2.1.2 Features of the FDR D-EVO

This section describes the main features of the FDR D-EVO.

- 1 The external dimensions and the weight of the flat panel sensor are the same as those of the conventional cassette used for general exposure. Due to this feature, the flat panel sensor can be inserted into the radiographic examination stand that has been used, allowing the user to avoid cassette replacement.
- 2 The flat panel sensor can be connected/disconnected with the relay connector of the connection cable. This allows the user to carry the flat panel sensor and insert/remove it into/from the upright-type or bed-type radiographic examination stand more easily.
- 3 The light weight and the thin and round design increase the operability of the flat panel sensor, making it possible to place it under a lying patient.
- 4 An image can be displayed on the Console within approximately 5 seconds after making an exposure.
- 5 Owing to the highly sensitive flat panel sensor, X-ray exposure dose can be reduced accordingly.
- 6 Due to the effects of digital image processing, the system produces X-ray images that have a high diagnostic value and are easy to observe.
- 7 The system has a wide latitude for incident X-rays so that a large amount of X-ray diagnostic information is obtained.
- 8 As the system has a wide latitude and an automatic sensitivity adjustment function, its X-ray images are not affected by small changes in X-ray exposure conditions. Therefore, consistent image density is obtained for all images.
- 9 Image processing parameters are automatically selected through an anatomical region selection system from the Console.
- 10 Multi-objective Frequency Processing (MFP), a newly introduced image processing function, not only improves the image quality also achieves high-speed image processing.
- 11 A DICOM-conformed open network can be supported by connecting the Console.
- 12 With the flat panel sensor (DR-ID 601SE), wireless communication mode or wired communication mode can be selected. In wireless communication mode, exposures can be performed without connecting the cable.



2.2 Unit Names and the Functions

Unit names and the functions of the FDR D-EVO are described below.

2.2.1 DR-ID 600

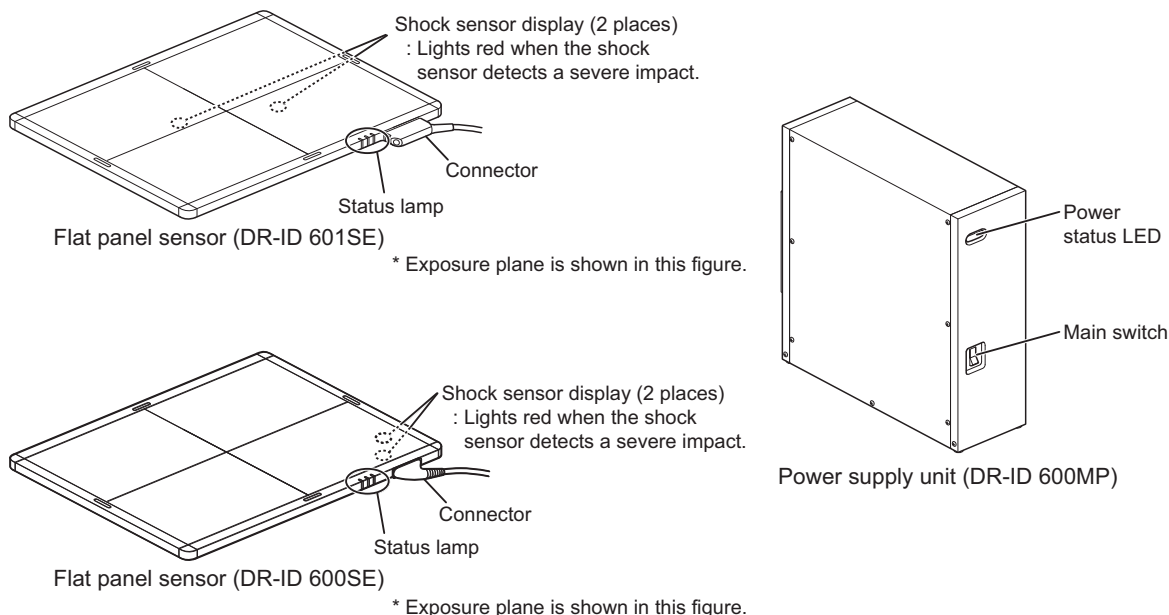
■ DR-ID 600PU



Name	Description												
Flat panel sensor (DR-ID 601SE) (DR-ID 600SE)	A unit incorporating a GOS indirect panel. There are two types of flat panel sensors: DR-ID 601SE (wireless/wired communication mode) and DR-ID 600SE (wired communication mode).												
Status lamp	Indicates the equipment status by LEDs.												
READY  (Green)	<table border="1"> <thead> <tr> <th></th> <th>Wireless</th> <th>Wired</th> </tr> </thead> <tbody> <tr> <td>(In wireless communication mode, the status of the battery pack is indicated. In wired communication mode, whether or not exposures can be performed is indicated.)</td> <td>OK (Exposure possible)</td> <td>Exposure possible</td> </tr> <tr> <td>Blinks for 1.0 second.</td> <td>Less than 10 min. (Charge required)</td> <td>During exposure sequence</td> </tr> <tr> <td>Off</td> <td>Empty (Power OFF)</td> <td>Ready</td> </tr> </tbody> </table>		Wireless	Wired	(In wireless communication mode, the status of the battery pack is indicated. In wired communication mode, whether or not exposures can be performed is indicated.)	OK (Exposure possible)	Exposure possible	Blinks for 1.0 second.	Less than 10 min. (Charge required)	During exposure sequence	Off	Empty (Power OFF)	Ready
	Wireless	Wired											
(In wireless communication mode, the status of the battery pack is indicated. In wired communication mode, whether or not exposures can be performed is indicated.)	OK (Exposure possible)	Exposure possible											
Blinks for 1.0 second.	Less than 10 min. (Charge required)	During exposure sequence											
Off	Empty (Power OFF)	Ready											
POWER  (Green)	Comes on when the system is turned on.												
ERROR  (Orange)	<table border="1"> <tbody> <tr> <td>On</td> <td>Communication not possible.</td> </tr> <tr> <td>Blinks for 1.0 second.</td> <td>Error occurred</td> </tr> <tr> <td>Off</td> <td>Normal</td> </tr> </tbody> </table>	On	Communication not possible.	Blinks for 1.0 second.	Error occurred	Off	Normal						
On	Communication not possible.												
Blinks for 1.0 second.	Error occurred												
Off	Normal												
* All LEDs are off when the equipment is off.													
Power supply unit (DR-ID 600MP)	Supplies the power to the flat panel sensor and connects the flat panel sensor and the control cabinet.												
Main switch	Supplies the power to the flat panel sensor and the inside of the power supply unit.												
Remote switch (optional)	Turns on/off the power to the flat panel sensor.												
Power status LED	Displays ON/OFF of the power supply unit.												

■ DR-ID 600MC

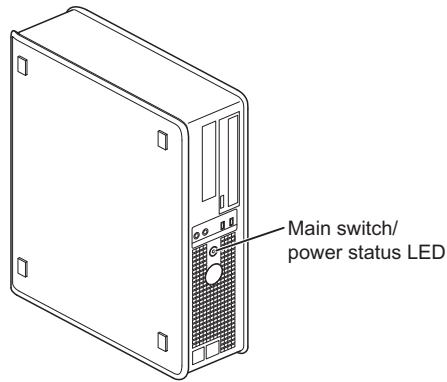

Control cabinet (DR-ID 600MC)

Name	Description
Control cabinet (DR-ID 600MC)	A personal computer used for controlling the flat panel sensor and performing image processing.
Main switch	Supplies the power to the control cabinet.
Power status LED	Displays ON/OFF of the control cabinet.

■ Battery charger (Optional)

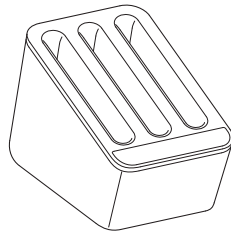

Battery charger

Name	Description
Battery charger	Charges the battery pack (optional) for the flat panel sensor (DR-ID 601SE). Three packs can be charged at the same time.
Charge status indicator LED	Indicates charge status.

■ Access point

- Product compliant with IEC60950, UL60950, PSE or JIS
- Compliant with IEEE802.11n [W52] (in the 5.2GHz band) /36, 40, 44, 48ch
- WLAN interface: 1000BASE-T/100BASE-TX (minimum requirements)
- LAN interface: 1000BASE-T/100BASE-TX (minimum requirements)
- Available OS: Linux
- Compliant with UL
- Compliant with FCC part15

■ DR-ID 300CL

- 🔍 For the unit names and functions of the DR-ID 300CL, see the “DR-ID 300CL Operation Manual”.

2.3 Console Display Configuration

When the self-initialization process ends, the Patient Information Input Screen will appear on the Console display.

For details, see “DR-ID 300CL Operation Manual”.

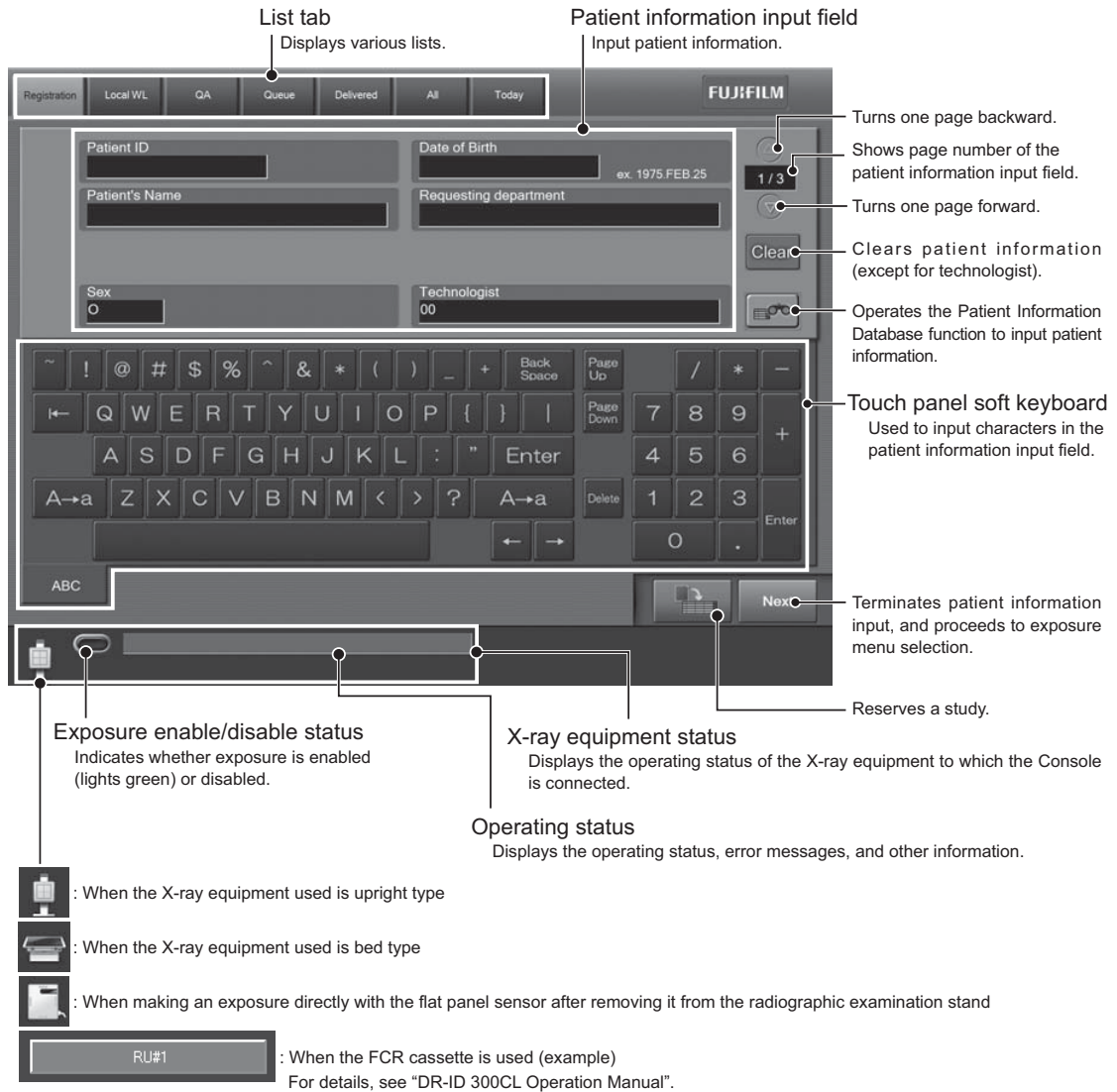

2.4 Routine Operation Diagram

The system configuration and the routine operation diagram for the FDR D-EVO is as follows.

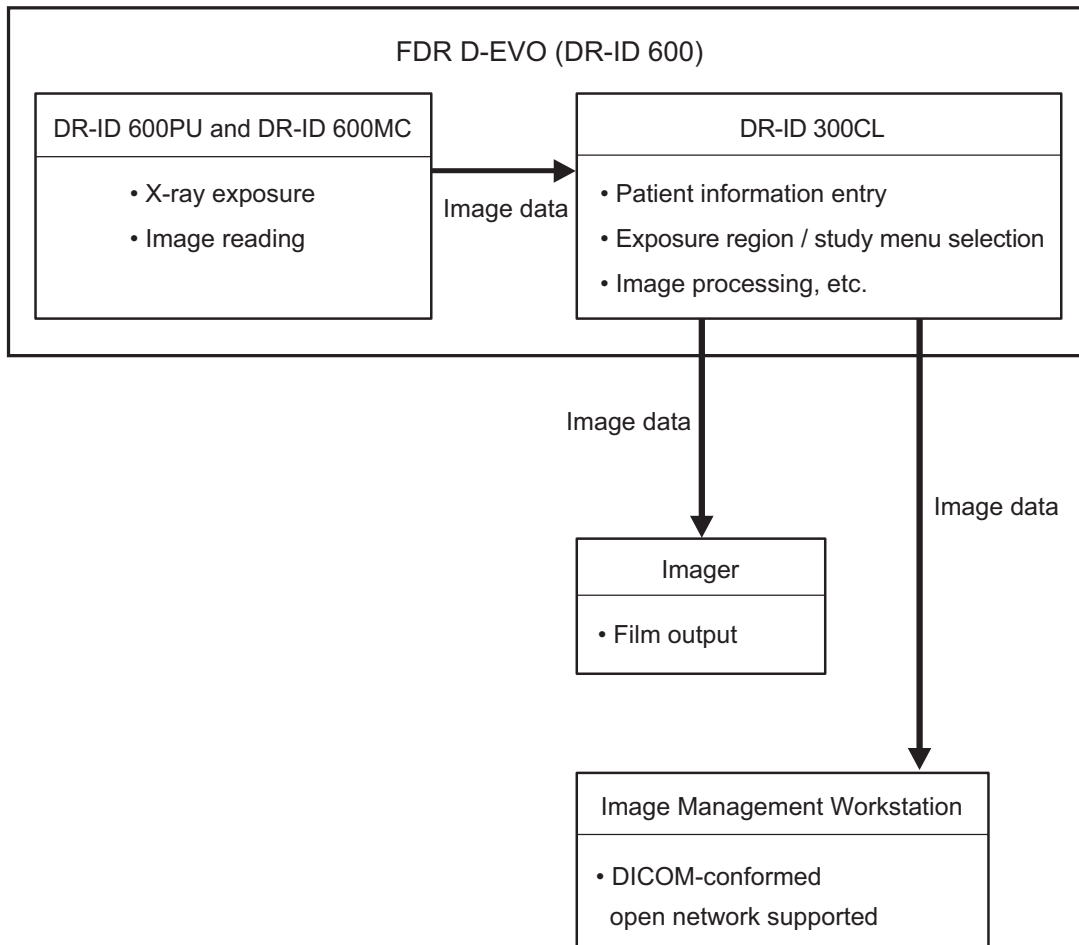

Chapter 3 Basic Operation

3.1 Preparing the Flat Panel Sensor

This section describes how to prepare the flat panel sensor.

3.1.1 Type of Flat Panel Sensor

DR-ID 601SE : Wireless communication mode or wired communication mode is available. When used in wireless communication mode, an access point*¹, battery pack (optional) and battery charger (optional) are required.

*¹ In the countries other than the U.S., an access point is not included as a component of the system. For details including installation, consult our official dealer.

- Product compliant with IEC60950, UL60950, PSE or JIS
- Compliant with IEEE802.11n [W52] (in the 5.2GHz band) /36, 40, 44, 48ch*Frequency Tolerance: ±20ppm
- WLAN interface: 1000BASE-T/100BASE-TX (minimum requirements)
- LAN interface: 1000BASE-T/100BASE-TX (minimum requirements)
- Available OS: Linux
- Compliant with UL
- Compliant with FCC part15



CAUTIONS

Use only one access point. A communication error may occur if two units or more are used.

DR-ID 600SE : Wired communication mode

3.1.2 Number of the Connectable Flat Panel Sensors

To enable the flat panel sensor, its ID needs to be registered in advance by a FUJIFILM dealer.

Up to five flat panel sensors can be registered.

Up to three flat panel sensors*² can be connected to the power supply unit at the same time.

*² When three flat panel sensors are connected at the same time, two power supply unit are required.

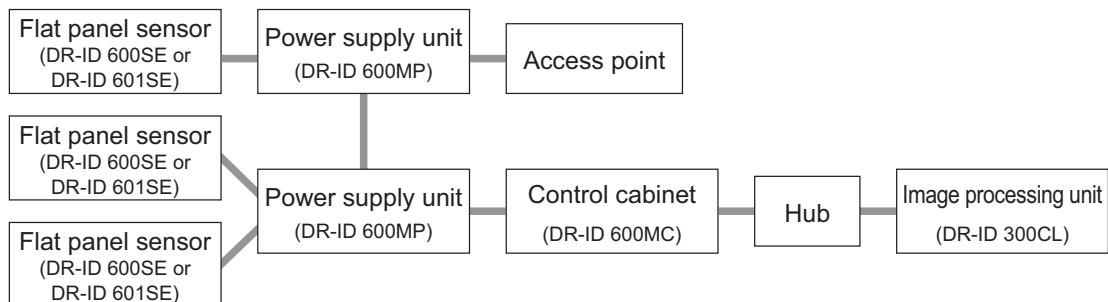

3.1.3 Connecting/Disconnecting the Flat Panel Sensor (DR-ID 601SE) Connector

When used in wireless communication mode, disconnect the connector.

1 Disconnect the connector.

Press the latches on both sides of the connector.

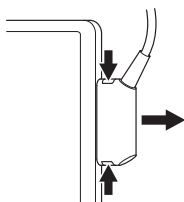

2 Connect the connector.

Press the connector into the insertion section.

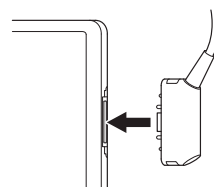

3.1.4 Connecting/Disconnecting the Sensor Cable Relay Connector for the Flat Panel Sensor (DR-ID 600SE)

Follow the procedure below to connect/disconnect the sensor cable relay connector.



- Do not connect the flat panel sensor to the power supply unit other than of the FDR D-EVO. Otherwise, the connector may be damaged.
- Do not connect the flat panel sensor unregistered to the system. Otherwise, the power to the flat panel sensor will be disconnected automatically. For details on the registration, contact a FUJIFILM dealer.
- When connecting/disconnecting the sensor cable relay connector, always hold the grip of the connector. The wire inside may be broken, if you connect/disconnect by holding the cable. If you turn the outer bushing of the grip, the cable lock becomes loose, causing a short-circuit of the cable.
- Do not drop the sensor cable relay connector when connecting/disconnecting it. Otherwise, personal injury may result, or properties or the connector may be damaged.

- 1** Make sure that the READY lamp of the flat panel sensor is not blinking, and press the OFF side of the power supply unit. Alternatively, turn off the flat panel sensor by pressing the operation button on the optional remote switch, and make sure that the POWER lamp of the flat panel sensor turns off.

- 🔊 For the external view of the optional remote switch, see “O.2 Using the Remote Switch” (page O-2).



The remote switch can be simultaneously connected to both the upright type and the bed type.

The relay connector can be connected/disconnected by turning off either of the remote switches.



You can proceed to the next step even if an error message appears after turning off the power supply unit.

- 2** To disconnect, hold the grips A and B of both the connectors, and then pull the grip A of the flat panel sensor to unlock.

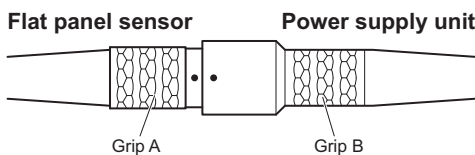

CAUTIONS

If you skip Step **1** and perform Step **2**, a communication error occurs. In such a case, turn the power back on to the power supply unit. Note, however, that repeating this action may result in damage to the equipment.

- 3** To connect, align the positioning marks, and then push the connectors in.

Align the positioning mark on the connector of the power supply unit with that of the flat panel sensor, and then insert the connectors by slightly turning them.

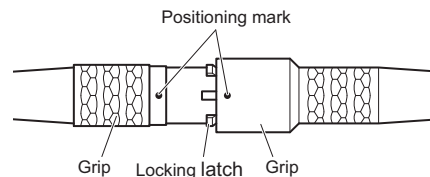

Push in until you feel a click.

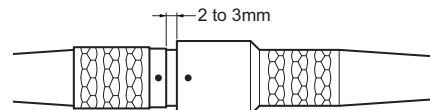

Push further in to the position shown in the figure in Step **2** until you feel a click again to lock them into place.

- 4** Press the ON side of the main switch of the power supply unit, or press the operation button on the optional remote switch.

3.1.5 Inserting/Removing the Flat Panel Sensor into/from the Radiographic Examination Stand

Follow the procedure below to insert/remove the flat panel sensor into/from the radiographic examination stand.

For details, see the Operation Manual for the radiographic examination stand.

CAUTIONS

For the positioning at the time of inserting/removing the flat panel sensor, see the Operation Manual for the radiographic examination stand.

CAUTIONS

Be careful not to have your fingers caught when inserting/removing the flat panel sensor into/from the radiographic examination stand.



For the effective area of the flat panel sensor, see “■ DR-ID 600PU” (page A-4).

[1] Upright type

When inserting from the right-hand side

CAUTIONS

When inserting the flat panel sensor into the radiographic examination stand, direct the exposure plane toward the X-ray tube.

1 Pull out the tray.

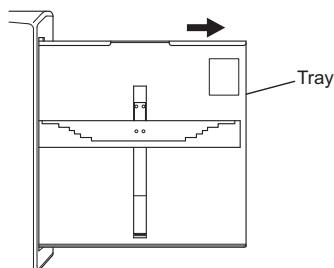

2 Insert the flat panel sensor into the cassette receive while the connector directed to the upper right, and then move it downwards.

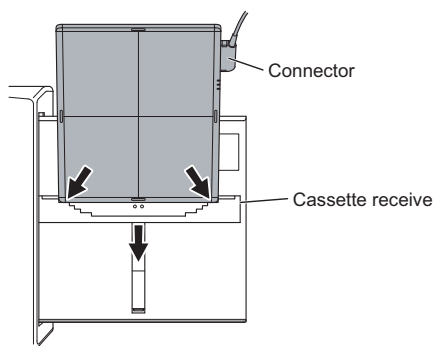

3 Set the flat panel sensor to the upper part of the tray.

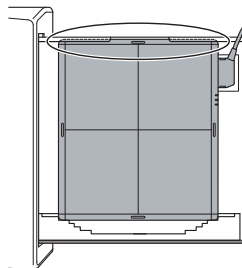

4 Push the tray back into place after setting the flat panel sensor.

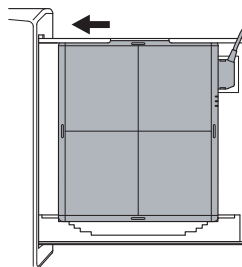

When inserting the flat panel sensor from the left-hand side, direct the connector to the lower left.

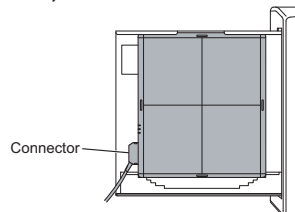

5 When removing the flat panel sensor

Pull out the tray, push the cassette receive downwards, and then remove the flat panel sensor. Push the tray back into place.

[2] Bed type



CAUTIONS

When inserting the flat panel sensor to the radiographic examination stand, direct the exposure plane upwards.

- 1 Pull out the tray by using the handle.

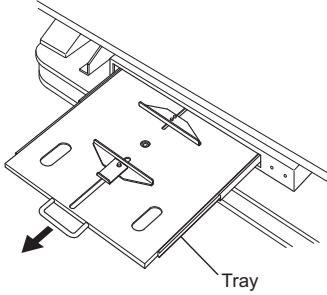

- 2 Pull the cassette stopper, and set the flat panel sensor so that its center mark is aligned with the center of the stopper.

Position the connector of the flat panel sensor as shown in the figure below.

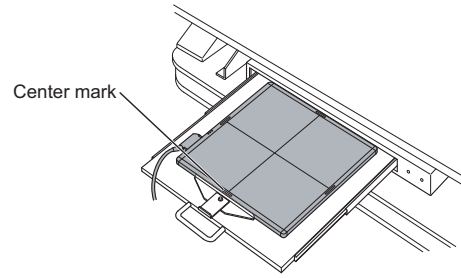
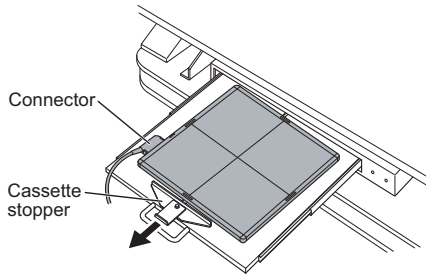

When setting the flat panel sensor horizontally, position the connector as shown in the figure below.

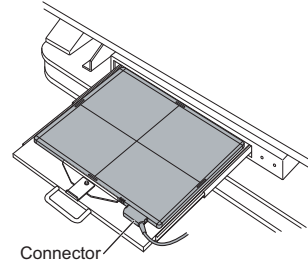

- 3 Push the tray back into place by using the handle after setting the flat panel sensor.

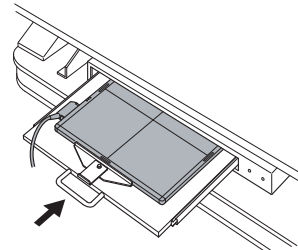

- 4 When removing the flat panel sensor

Hold the handle and pull out the tray. Remove the flat panel sensor while pulling the cassette stopper, and then push the tray back into place.

3.1.6 Changing the Direction of the Flat Panel Sensor Connector

The direction of the connector of the flat panel sensor can be changed, depending on how it is inserted into the radiographic examination stand.

To change the direction, contact a FUJIFILM dealer.

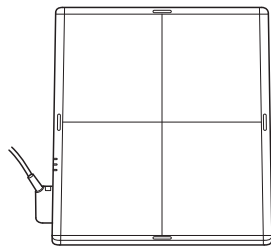

When shipped

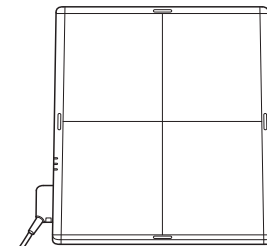

After changing the direction

3.1.7 Charging the Battery Pack (Optional) for the Flat Panel Sensor (DR-ID 601SE)

When used in wireless communication mode, charge the battery pack using the battery charger (optional).



When the battery pack is fully charged, exposures for a maximum of approximately 200 images can be performed. However, the number varies depending on the usage conditions.



The capacity of the battery is displayed on the READY status lamp and in the Console display.



When the remaining capacity of the battery pack becomes "Less than 10 min." (the READY status lamp blinks every one second), exposures cannot be performed. If this happens, perform the following operations.

- Replace or charge the battery pack.
- Connect the connector to the flat panel sensor.



When the connector is connected to the flat panel sensor, exposures in wired communication mode and charging the battery pack can be performed. However, this type of charging is not recommended.



Charge the battery pack using the battery charger.

In wireless communication mode, when the remaining capacity of the battery pack becomes insufficient, exposures are prohibited and the READY status lamp blinks every one second. If the flat panel sensor is used in wireless communication mode for another 10 minutes or so, the battery pack is not charged even if the SE cable is connected. If this happens, remove the battery pack and charge it using the battery charger. When the battery pack is charged using the battery charger for about one minute, charging the battery pack by connecting the SE cable become available.

1 Set the battery pack in the battery charger.

When the battery pack is set, a buzzer sound is generated and the charge status indicator LED lights.

Three battery packs can be charged at the same time.

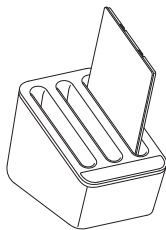

2 When battery charge is completed, remove the battery pack.

When battery charge is completed, the charge status indicator LED changes from blinking to lighting.

3.1.8 Installing/Removing the Battery Pack (Optional) for the Flat Panel Sensor (DR-ID 601SE)

Follow the procedure below to install/remove the battery pack for the flat panel sensor (DR-ID 601SE).

1 Remove the battery cover.

Place the flat panel sensor with the back side facing upward and then press the right-hand and left-hand slide locks to remove the battery cover.

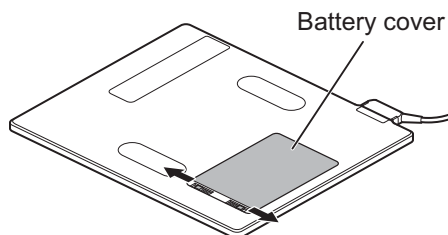

2 Install the battery pack.

Align the battery pack with the flat panel sensor (DR-ID 601SE) by using the guide marks. While pressing the battery pack (1), press down the opposite side (2) as shown in the figure below.



When the battery pack is installed, the power is automatically turned on.

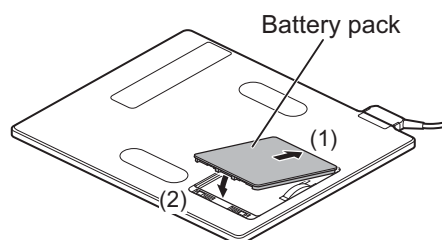

- To remove the battery pack, perform the same procedure as Step **1** (removing the battery cover).
- To install the battery cover, perform the same procedure as Step **2** (installing the battery pack).

3.2 Starting Up and Shutting Down the System

This section explains how to start up and shut down the system. To start up the system, operations are required on the FDR D-EVO main unit and on the Console.

To shut down the entire system, operations are required only on the Console.

3.2.1 Starting Up the System

1 Press the ON side of the main switch of the power supply unit, if its power status LED is not lit.

2 After confirming the following items, press the power switch for the Console to start the initialization process.

- All cables should be connected properly.
- No media should be inserted into the FDD.

The control cabinet starts up automatically.



CAUTIONS

If the power status LED of the power supply unit does not come on after turning on the Console, turn on the control cabinet.

3 Turn on the radiographic examination stand.

4 After displaying the start-up progression status, software version, and initialization progression status, the activation completion screen below will be displayed on the Console.

Activation completion screen of the Console



CAUTIONS

An error occurs if the system is started up immediately after shutdown.

To restart the system, make sure that the power status LED of the power supply unit is off, and then press the power switch for the Console.

3.2.2 Shutting Down the System

- 1 Confirm that the equipment is not running. Touch the **FUJIFILM** button at the upper right of the Console display, and then the **Shut Down** button from the displayed menu. Touch the **OK** button in the displayed confirmation window.

The Console will shut down in a few minutes. The control cabinet will also turn off automatically.

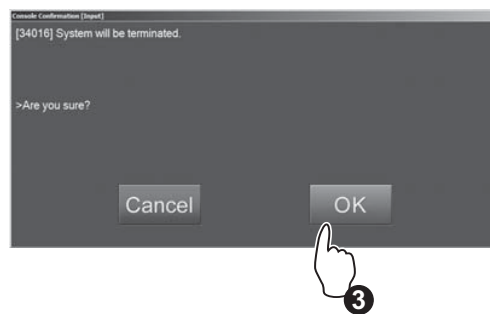
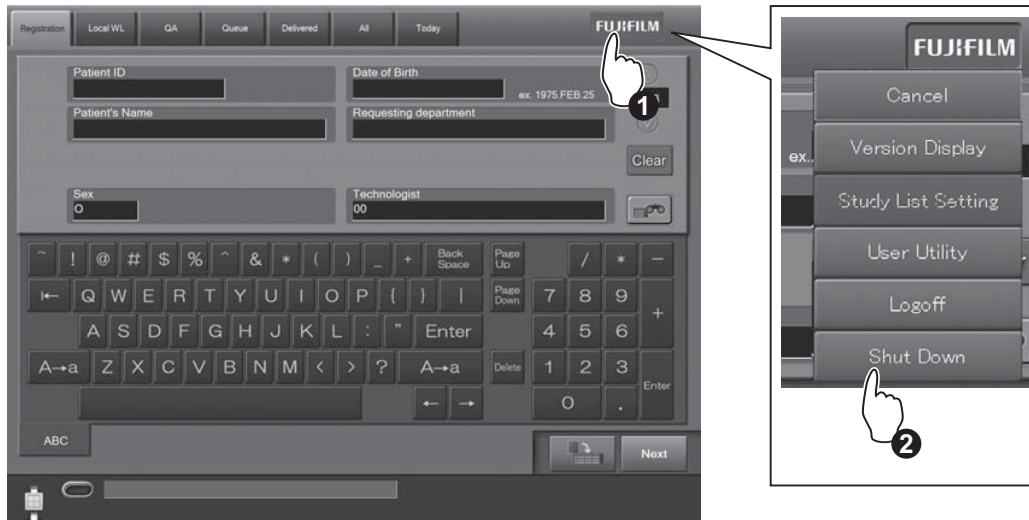

- 2 Turn off the display as necessary.
- 3 Turn off the radiographic examination stand.



Normally, it is not necessary to turn off the power supply unit.



CAUTIONS

Do not turn off the control cabinet with the main switch.
Shutdown operation may not be performed normally.

3.3 Routine Operations

FDR D-EVO routine operations can be broadly divided into the following three steps.

Step 1 Entering the Patient Information ▶ (See page 3-10.)



Step 2 Selecting the Anatomical Region and Exposure/Study Menu ▶ (See page 3-11.)



Step 3 X-ray Exposure ▶ (See page 3-13.)

 **HINT**

Operations that are actually performed on the FDR D-EVO are only those described in “Step 3 X-ray Exposure”. Other operations are performed on the Console.

▶ For details, see “DR-ID 300CL Operation Manual”.

Step 1 Entering the Patient Information

1 The Study Information Input Screen below is displayed on the Console display immediately after startup.

Enter patient information items appropriately, and then touch the **Next** button.



Not all the items of patient information need to be input.
Input any one of the items in order to proceed to the next operation.



When the optional card reader is provided, patient information can be input by reading from a magnetic card.

List tab
Displays various lists.

Patient information input field
Input patient information.

Turns one page backward.

Shows page number of the patient information input field.

Turns one page forward.

Clears patient information (except for technologist).

Operates the Patient Information Database function to input patient information.

Touch panel soft keyboard
Used to input characters in the patient information input field.

Terminates patient information input, and proceeds to exposure menu selection.

Reserves a study.

Exposure enable/disable status
Indicates whether exposure is enabled (lights green) or disabled.

Operating status
Displays the operating status, error messages, and other information.

Registration Local WL QA Queue Delivered All Today FUJIFILM

Patient ID: 1234567890 Date of Birth: 1975.FEB.25 ex. 1975.FEB.25

Patient's Name: JOHN SMITH Requesting department: Surgi#1

Sex: M Technologist: 00

1 / 3

Clear

Next

Patient information includes the following items.

Accession No. / Reception No. / Patient ID / Patient's Name / Sex / Date of birth / Requesting department code / Requesting department name / Technologist / Patient comment / Physical disorder information / Infection information / Contraindication information / Pregnancy / Height (cm) / Weight (kg) / Telephone no. / Outpatient/Inpatient / Blood type (ABO) / Blood type (Rh) / Comments on study



HINT

You can change patient information input items and their display order in the User Utility settings.

Step 2 Selecting the Anatomical Region and Exposure/Study Menu

- 1 The Exposure Menu Selection Screen is displayed.
Touch an anatomical region to display the desired exposure menu, and then touch an exposure menu (more than one menu can be selected). The selected exposure menu(s) is displayed in the selected exposure menu list on the right side of the screen.

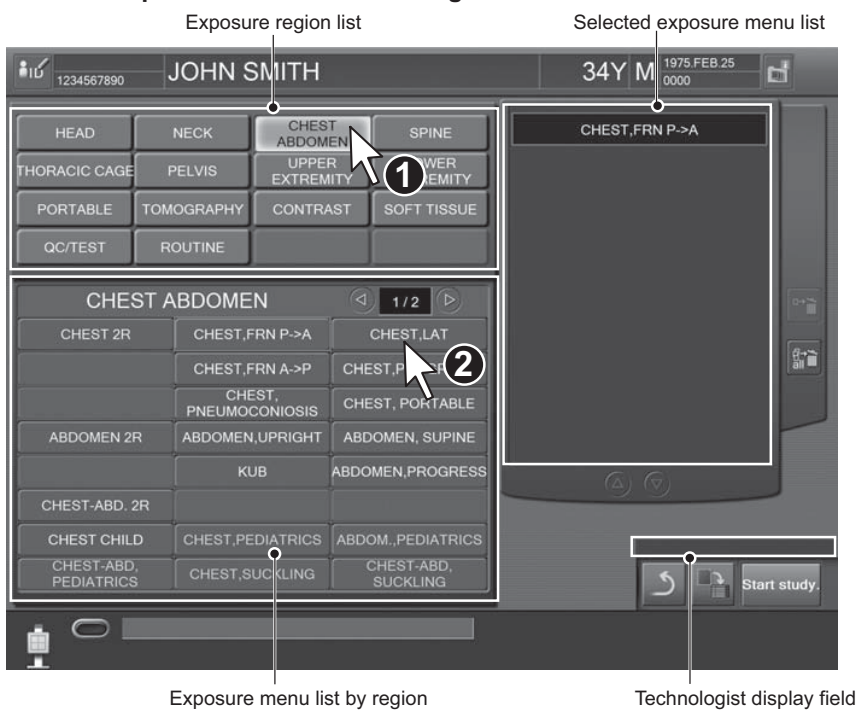

- 2 Touch **Start study** after selecting exposure menu(s).



- The Study Screen is then displayed.
Operate appropriately according to display mode (one-image display/six-image display) on the Study Screen.
The mode can be switched alternately by touching .

One-image display mode



Six-image display mode



Step 3 X-ray Exposure

When settings on the Console have been completed, you can perform an exposure.



CAUTIONS

- Make sure to identify a patient against the name or birth date and then have him (her) take a proper positioning for exposure.
- Make sure to confirm the exposure menu to be used and then have a patient take a proper positioning for exposure.
- When multiple panels are used, make sure that the READY lamp among the status lamps of the flat panel sensor is lit in order to confirm that it is the correct one for the selected technique.

[1] Positioning the patient

Position the patient.



CAUTIONS

Exercise due care so that an intravenous line or drain tube put to a patient does not hook into the equipment.



For the exposure position of the upright-type/bed-type radiographic examination stand, see its Operation Manual.

When making an exposure directly using the flat panel sensor, set the exposure position by reference to the effective area.

- For details on the effective area, see “■ DR-ID 600PU” (page A-4).

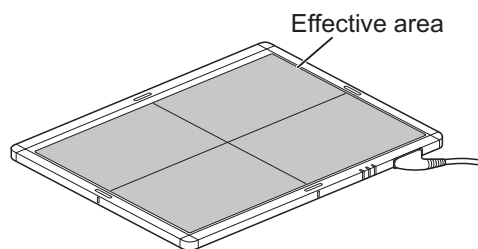

[2] X-ray exposure/Image displaying



Make sure that exposure is possible on the Console, and then perform X-ray exposure.

Perform exposures having the patient hold tight the grip handles if necessary. Exposed images are transferred to the Console.

One-image display mode

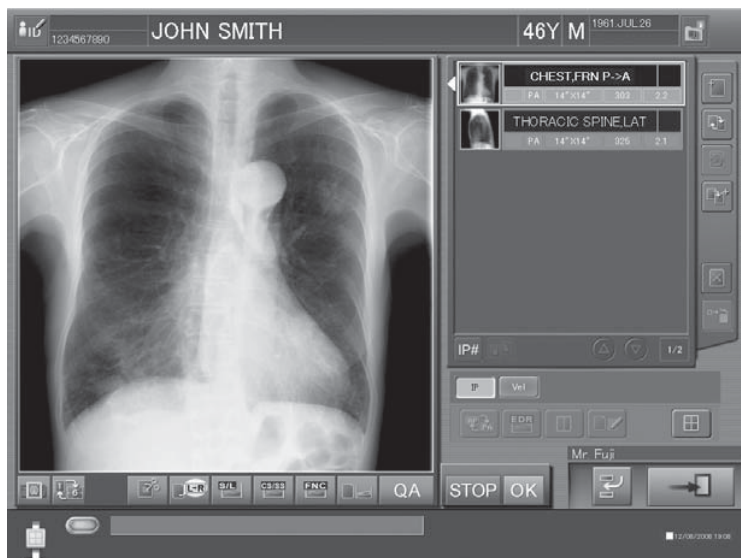

Six-image display mode

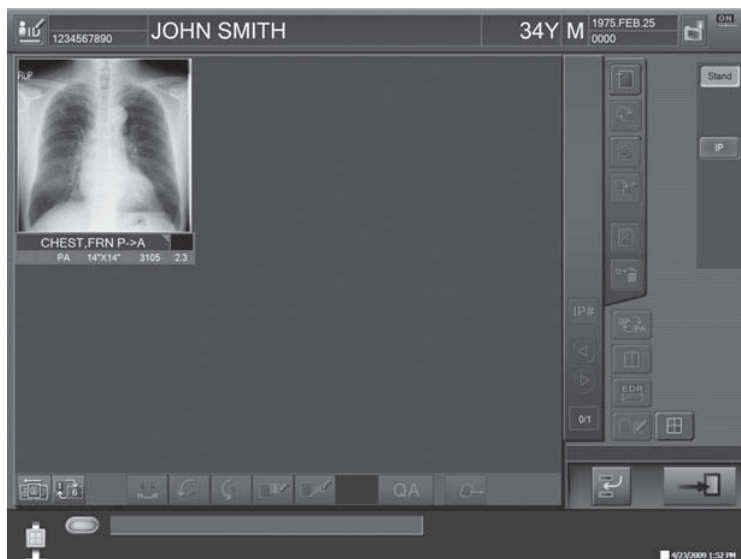

Touch the  button at the lower right to complete the study.



To prepare for exposures of the next patient, repeat **Step 1** through **Step 3**.



Touch this button.

The registration of the next new patient should be processed after more than 2 seconds.

[3] For exposures of the next patient using the same menus

- 1 To make exposures of the next patient using the same menus, touch the  button at the upper left instead of the  button.



- 2 The Patient Information Input Screen below appears. Touch  at the lower right to clear off patient information used for the previous patient, and then input new patient information items in the same screen.

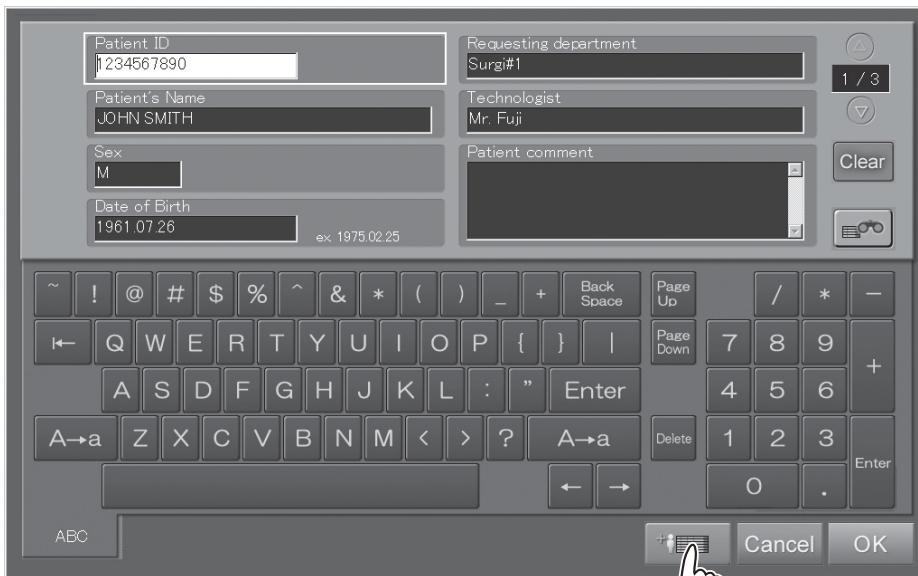

Touch this button.



When the optional card reader is provided, patient information can be input by reading from a magnetic card.

- 3 After patient information for the next patient has been input, touch the  button at the lower right of the screen.

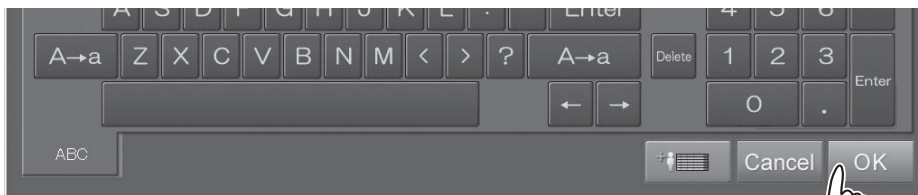

Touch this button.

With the exposure/study menus retained as they are, registration of exposure menus completes for the next patient.



Chapter 4 Troubleshooting

4.1 When a Message Appears on the Console

This section describes the warning dialog box and error messages.

If an error which cannot be handled or the same error recurs frequently, contact a FUJIFILM dealer.

If an error of unknown cause occurs, do not continue the operation and contact a FUJIFILM dealer.

[1] If a warning dialog box appears

If a communication error or an unexpected error has occurred, a warning dialog box pops up on the screen. In such a case, after checking error details and closing the box, take appropriate action immediately. Be sure not to continue the operation of the Console without taking an appropriate action.

If any operation is performed while a warning dialog box is displayed, another screen may be displayed, hiding the dialog box behind. In this case, press the [Enter] key to close the hidden box.

[2] If a communication error occurs between the Console and the connected DR system

The error message box ID: 31449 is displayed not only when the Console starts up but also when a communication error occurs.

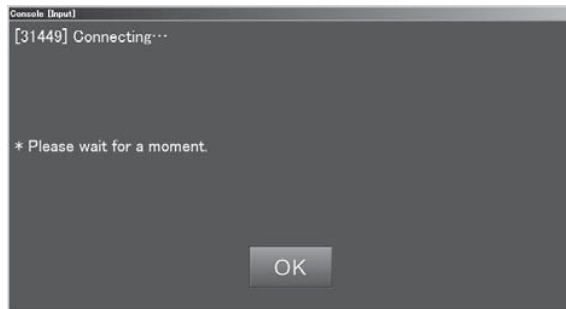

When the problem is not solved within a short time after the message box is displayed, perform the following procedure.

- 1** Select [OK] on the message box.
- 2** Check if the equipment connected with the Console is turned on.
If any equipment is turned off, turn it on and wait for a while.
- 3** If the problem is not solved, shut down the Console.
- 4** Make sure that the power status LED of the control cabinet is off, and then restart the Console.



If the power status LED of the control cabinet does not turn off even after approximately 10 minutes have passed following the shutdown of the Console, press and hold the main switch of the control cabinet.

When the Console is restarted and the same error message box is displayed, contact a FUJIFILM dealer.

[3] If an error occurs on the Console

If an error occurs on the Console, an error message box is displayed on the screen.
In such a case, check error details and select [OK] in the box, and then take an appropriate action.

[4] If an error occurs on an output destination device

If an error occurs on an output destination device,  is displayed at the upper right of the screen.
In such a case, operate as follows.
Select .

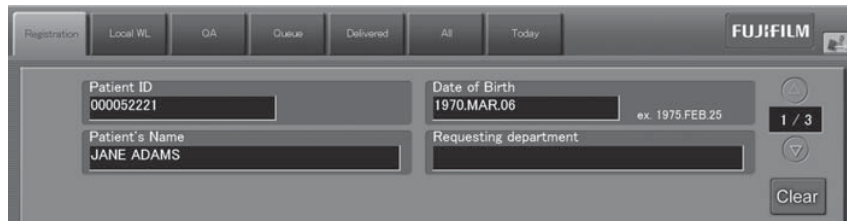

The screenshot shows the FUJIFILM console interface. At the top, there are navigation tabs: Registration, Local WL, OA, Queue, Delivered, All, and Today. The FUJIFILM logo is in the top right corner. Below the tabs, there are input fields for Patient ID (000052221), Date of Birth (1970.MAR.06), Patient's Name (JANE ADAMS), and Requesting department. A printer icon is visible in the top right corner of the interface.

An error display box is displayed.
Check the connection status, select , and then take an appropriate action.

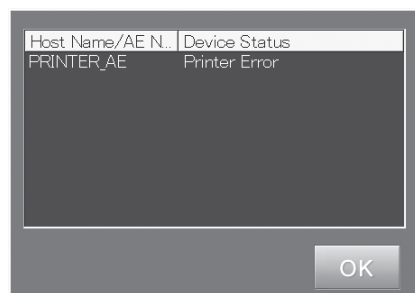

The screenshot shows an error display box with the following content:

Host Name/AE N...	Device Status
PRINTER_AE	Printer Error

An OK button is located at the bottom right of the box.

"Error display box"

4.2 How to Cope with an Error...

[1] When the system hangs up...

If an inappropriate processing is performed while this equipment is operating, the screen may freeze and the system may hang up (processing disabled). In that case, shut down the equipment forcibly according to the following procedure, and then restart it.



If the screen freezes and a hang-up occurs, remove the keyboard and mouse and reconnect them. If this operation does not solve the problem, restart the Console.

1 Press the [Ctrl] + [Alt] + [Del] keys simultaneously.

2 “Windows Security” is displayed.

Select [Start Task Manager].

3 “Windows Task Manager” is displayed.

Select “IIPMAIN.exe” in the list in the “Processes” tab, and then click [End Process].

4 The message box is displayed.

Click [End Process] to terminate the Console.

Depending on equipment status, an error message may not be displayed.

5 The desktop screen of the operating system (Windows Vista) is displayed.

Close the “Windows Task Manager window”, and then select the [Start] button at the lower left of the screen. Select [Restart] from the displayed menu.

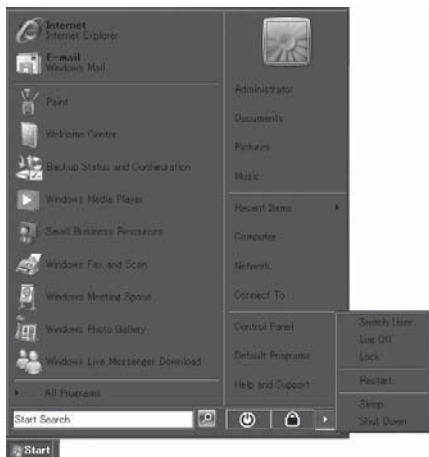

CAUTIONS

- Make sure to shut down the system following the above procedures in case of a hang-up of the Console. If the personal computer is turned off without shutdown, an error may occur on the computer.
- Note that forcible shutdown processing of the equipment is an emergency action. Do not use this action under normal situations.

6 Press and hold the main switch of the control cabinet to turn it off.

7 Press the OFF side of the main switch of the power supply unit.

[2] When the Console is turned off due to an electrical outage

When the Console is turned off due to an electrical outage, etc., take the following actions according to the condition when the power comes back on.

■ If the power comes back on soon after an electrical outage

Wait until the Console restarts.

When the Console has restarted, shut down the Console by following the normal procedure.

● For details of system shutdown, see the “DR-ID 300CL Operation Manual”.

To restart the Console, follow the procedure for the system startup.

[3] If a hard disk of the Console is damaged

If one of the hard disks is damaged, a window indicating so will appear. In such a case, press the F1 key and contact our official dealer.

[4] If a white image is displayed after an exposure

If a white image is displayed, a LAN communication error may have occurred.

Check if the LAN communication connectors are properly connected between the flat panel sensor and the power supply or and between the power supply unit and the control cabinet. Make an exposure again after confirmation.

[5] Precautions for operating the system when “Initializing” or “Changing FPD” is displayed in the Console’s operating status display at the time of replacing the flat panel sensor

When replacing the flat panel sensor by using the main switch of the power supply unit or the optional remote switch, “Initializing” or “Changing FPD” is displayed in the operating status display of the Console. While either of the status messages is displayed, you cannot register/select exposure menu(s), change the selector, etc.

Perform the operations above after the status message disappears.

[6] If wireless communication with the flat panel sensor (DR-ID 601SE) is not possible

If the flat panel sensor is not recognized in wireless communication mode, connect the connector to use the system in wired communication mode.

[7] If wireless communication mode is disabled when using the flat panel sensor (DR-ID 601SE)

If wireless communication is interrupted, an error message prompting reconnection is displayed after 30 seconds. Select “Yes”. If connection is not established even after the selection is made, connect the connector and retry the connection.

Chapter 5 Daily Inspection and Maintenance

5.1 Daily User Inspection and Maintenance

During maintenance and inspection, strictly observe precautions contained in “Chapter 1 For Safe Operation” in this manual for you to use the FDR D-EVO under best conditions.

5.1.1 Daily Inspection (DR-ID 600)

Inspection Before Use

- Make sure that the equipment starts up normally.
- Make sure that the equipment communicates with connected devices normally.
- Make sure that the time displayed is correct.
- ▶ See “3.2 Starting Up and Shutting Down the System” (page 3-6).

Inspection During Use

- Make sure that images are output normally.
- ▶ See “3.3 Routine Operations” (page 3-8).

Inspection After Use

- Make sure that the power turns off normally by shutting down the equipment.
- ▶ See “3.2 Starting Up and Shutting Down the System” (page 3-6).

Cleaning instructions

Use a neutral detergent or ethanol to clean the outer surfaces.



CAUTIONS

- Do not use a solvent such as thinner or benzene, as it corrodes the outer surfaces.
 - Make sure not to let water, detergent and ethanol get inside the equipment.
-

5.1.2 Periodical Inspection

Inspection Every Three Months

Using a vacuum cleaner, remove any dirt or dust accumulated in each unit of the equipment once every three months. Clean then with a slightly moistened soft cloth and wipe off any moisture with a dry cloth.

▶ See “2.2 Unit Names and the Functions” (page 2-3).

■ DR-ID 600

DR-ID 600PU

NO.	Unit	NO.	Unit	NO.	Unit
1	Flat panel sensor	2	Power supply unit	3	Power supply unit Air filter (1)
4	Remote switch (optional)				

Air filter

Clean the air filter on the rear of the power supply unit with a vacuum cleaner. Push down the lever at the top of the louver-and-filter assembly, and clean the air filter with a vacuum cleaner after detaching it from the assembly.

Remote switch (optional)

Clean the surface of the remote switch (optional) with a dry cloth, etc.



Be sure to turn off the equipment before cleaning the air filter or the remote switch (optional).

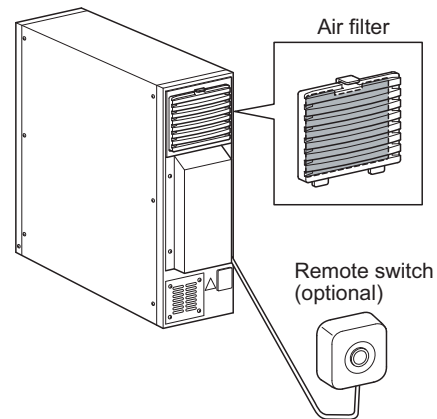

DR-ID 600MC

NO.	Unit	NO.	Unit
1	Control cabinet	2	Periphery of devices

Battery charger (Optional)

NO.	Unit
1	Battery charger (Optional)

Inspection Every Six Months

Check whether the S value remains unchanged once every six months.

5.1.3 Effective Period of Use

The effective periods of use of the flat panel sensors DR-ID 601SE and DR-ID 600SE and the power supply unit “DR-ID 600MP” are 6 years, as far as precautions in using them are strictly observed and regular maintenance and inspection are properly performed.
[According to self-certified data by FUJIFILM Corporation]

The control cabinet DR-ID 600MC and the image processing unit DR-ID 300CL are general-purpose PCs. Their effective periods of use are described in the operation manuals provided by the manufacturers.

Appendix A Specifications

A.1 Specifications

Specifications of the FDR D-EVO are shown below.

A.1.1 Processing Capacity (DR-ID 600)

- **Routine processing (when the two-image output format is used in standard mode)**

(1) **Exposure interval**

The exposure interval of the FDR D-EVO is at least 8 seconds.

However, the interval varies depending on the region, the load to network communication, etc.

A.1.2 Image Output (DR-ID 600)

- **Standard processing**

(1) **Film output**

Connection to the Imager makes it possible to obtain hard copies at the image reduction ratios and in the formats below.

- For standard pixel-density images

Output size	Reduction ratio	
	Two-image output	One-image output
14" × 17" (35 × 43cm)	61%	100%
14" × 14" (35 × 35cm)	61%	100%
10" × 12"	85%	100%
8" × 10"	100%	100%
18 × 43cm	100%	100%

[Fig. A.1]

(a) 14" × 17"
one-image output

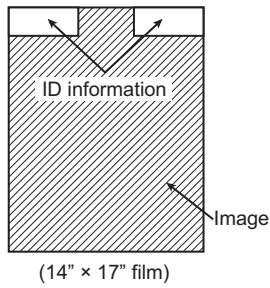

(b) 17" × 14"
one-image output

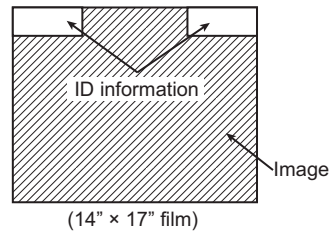

(c) 14" × 14"
one-image output

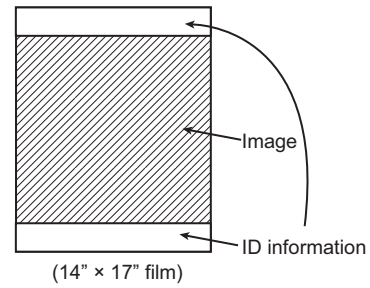

(d) 18 × 43cm
one-image output

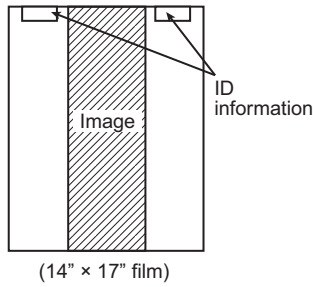

(e) 18 × 43cm
two-image output

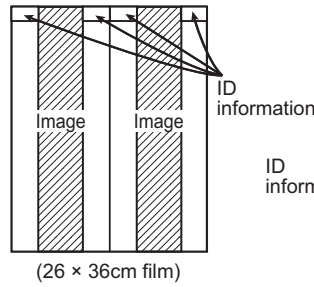

(f) 18 × 43cm
two-image output

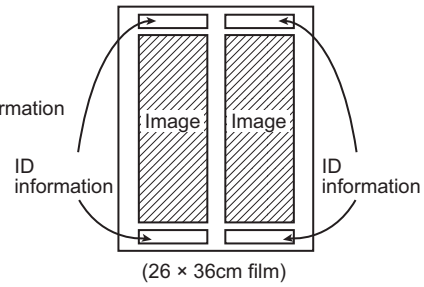

(g) Two-image output

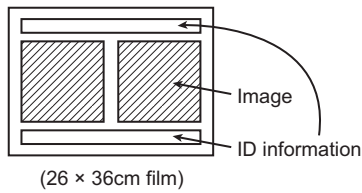

For one-image output using 17" × 14", 14" × 17", 14" × 14" or 18 × 43cm, images are output on 14" × 17" film. In other cases, images are output on 26 × 36cm film.



Depending on the printer connected or Console software version used, image outputs in the following formats are available.

- 100%-size output of 14" × 14" image on 14" × 14" film
- 100%-size output of 8" × 10" image on 8" × 10" film, as well as reduced image output on films of other sizes
- 100%-size output of 10" × 12" image on 10" × 12" film

A.1.3 Reduced Equivalent (DR-ID 600)

Peak reduced equivalent on the front panel of the flat panel sensor: 1.2 mmAl

A.1.4 Power Supply Conditions

■ DR-ID 600PU

Rated voltage: 100-240V \pm 10% ~

Input current : 1-0.42A

Frequency : 50-60Hz

■ DR-ID 600MC*

Rated voltage: 115/230V ~

Input current : 4.0/2.0A

Frequency : 50-60Hz

* Since the DR-ID 600MC is general-purpose electrical equipment, the electric rating above is an example.

A.1.5 Environmental Conditions

■ DR-ID 600PU

(1) Operating Conditions

Temperature : 15°C (15%RH) - 30°C (80%RH)

Humidity : 15%RH (15°C) - 80%RH (30°C) (no dew condensation)

Atmospheric pressure : 700hPa - 1060hPa

(2) Non-operating Conditions

(Environmental conditions under which power can be supplied)

Temperature : 5°C - 35°C (no dew condensation)

Humidity : 10%RH - 80%RH (no dew condensation)

Atmospheric pressure : 700hPa - 1060hPa

■ DR-ID 600MC

(1) Operating Conditions

Temperature : 10°C - 35°C

Humidity : 20%RH - 80%RH (no dew condensation)

Atmospheric pressure : 700hPa - 1060hPa

(2) Non-operating Conditions

(Environmental conditions under which power can be supplied)

Temperature : -40°C - 65°C

Humidity : 5%RH - 95%RH (no dew condensation)

Atmospheric pressure : 700hPa - 1060hPa

A.2 External View and Weight

The external view and weight of the FDR D-EVO are shown below.



Specifications, dimensions and weight are subject to change for improvement without prior notice.

A.2.1 DR-ID 600

DR-ID 600PU

	Width (mm)	Depth (mm)	Height (mm)	Weight (kg)
Flat panel sensor (DR-ID 601SE)	460	384	14	Approx. 3.1kg
Flat panel sensor (DR-ID 600SE)	460	384	14	Approx. 2.8kg
Power supply unit	120	350 (385)	350	Approx. 7.8kg

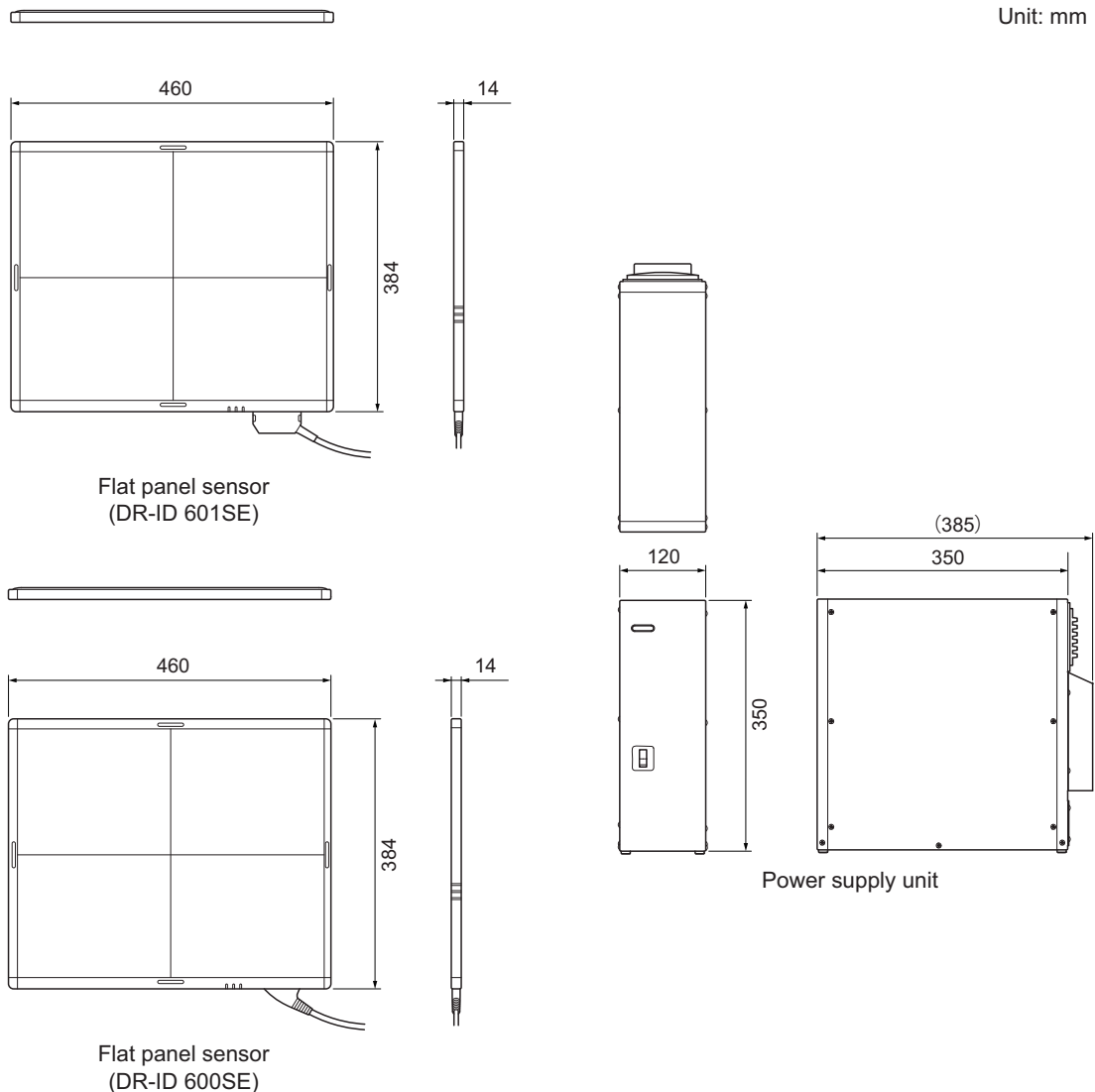



The effective area of the flat panel sensor is as shown in the figure below.

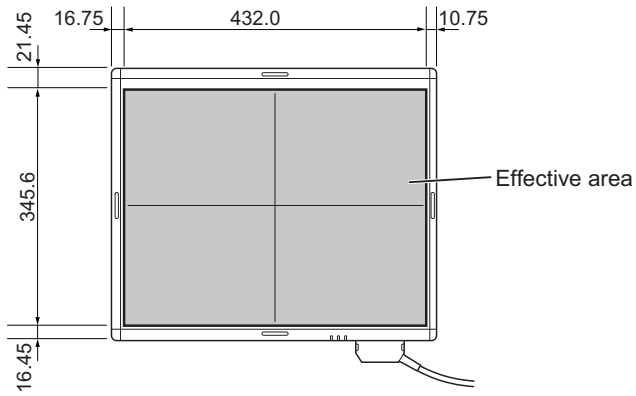

■ DR-ID 600MC

	Width (mm)	Depth (mm)	Height (mm)	Weight (kg)
Control cabinet	114	353	399	Approx. 8.3kg

Unit: mm

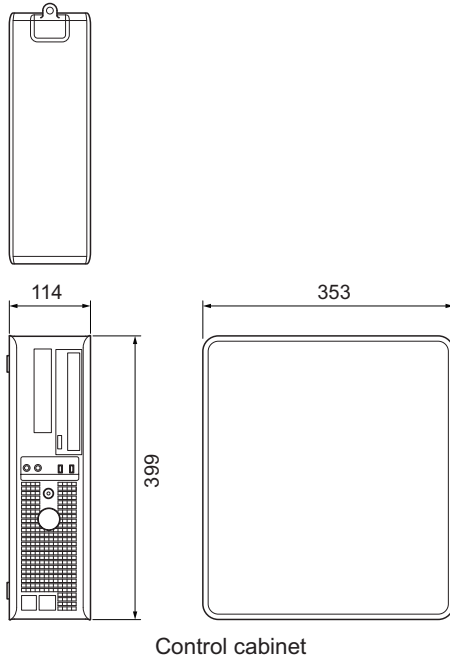

■ Battery charger

	Width (mm)	Depth (mm)	Height (mm)	Weight (kg)
Battery charger	120.2	219.8	136.2	Approx. xx kg

Unit: mm

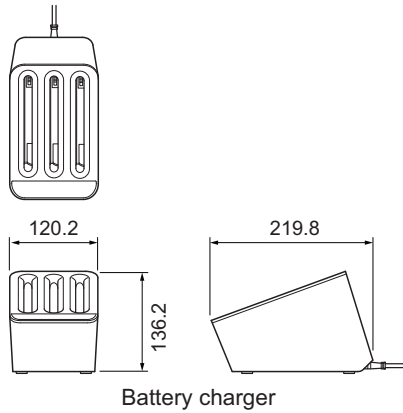

■ DR-ID 300CL

- For the external view and weight of the DR-ID 300CL, see the “DR-ID 300CL Operation Manual”.

Appendix Z Precautions for Exposure

Z1. Precautions for Exposure in AUTO MODE

In AUTO MODE, stable image output can be obtained by means of the following.

- (1) Radiation field
- (2) EDR image data analysis
- (3) Detailed depiction of the cervical region

However, problems may arise due to differences in the multiple diaphragms or scattered rays of the X-ray equipment. For such problems, contact a FUJIFILM dealer and use other recording modes, such as SEMI-AUTO MODE or FIX MODE.

Z.1.1 Radiation Field

- 1 Do not set the radiation field extremely small. Be sure to subject one-third or more of the length of each side of the bucky of the DR system to X-ray exposure.
- 2 Make sure that none of the sides of the radiation field overlap with the contrast medium. Errors will result if they overlap.

Available for Each Anatomical Region/Method

	Plain	Contrast Medium	Tomography
Head	4	4	4
Neck	4	4	–
Chest	4	4 (1 for esophagus)	–
Abdomen	4	4 (1 for stomach and intestines)	–
Pelvis	4	4	–

3 Notes on PRIEF

- [PRIEF 4] Used, with some exceptions, for both plain and contrast medium exposure menus, from the head to the pelvis.
The diaphragm shape will be any convex polygon, including rectangles, circles, ellipses, tracks, etc.

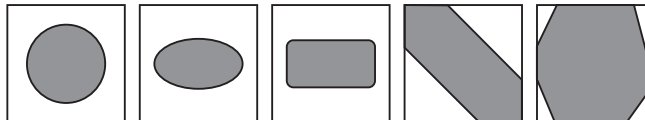

- [PRIEF 1] Used with esophagus, stomach and intestines contrast medium menus.

Z.1.2 Depiction of the Cervical Region

- 1 The radiation field must not include the whole head. Be sure to secure transparent portions on both sides of the neck.

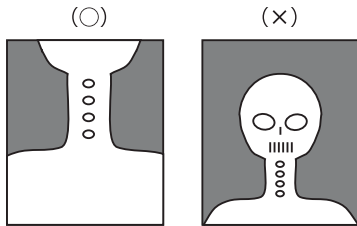

Use the “Head” menu to include the whole head in the radiation field.

- 2 For exposure of the pharynx or larynx, be sure that the neck comes to the center of the radiation field so that the frontal and lateral orientations can be recognized appropriately.

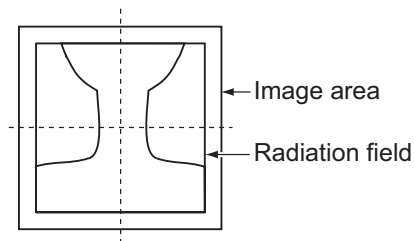

- 3 In pharynx and/or larynx exposure, do not use lead characters in the oblique line section.

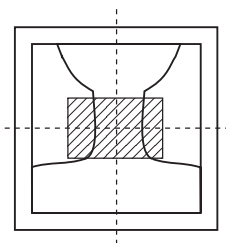

Z.1.3 Depiction of the HIP JOINT AXL – 2 Menu

- 1 Make sure to position the region of interest within the slanted-line area shown below. Do not collimate further inside.
- 2 Positioning should be done so that the condyle and the femur run along the longer edge. (Do not position them against the shorter edge.)

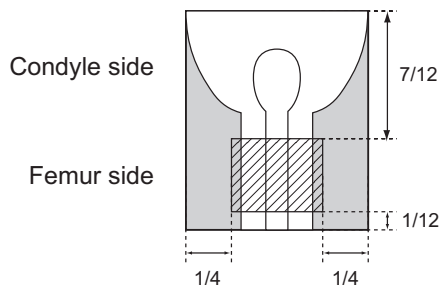

Z.1.4 EDR Image Data Analysis

1 Image unevenness appearing when the grid used in exposure is not positioned correctly in terms of the bulb, when there are shadows from clothing, or when X-ray radiation of the X-ray exposure area is uneven is a problem that arises during EDR image data analysis, which cause unstable density on the image.

Avoid such unevenness in the X-ray exposure area as far as possible.

2 If the target includes such materials as gypsum, denture, etc., stable density may not be obtained, because such materials make it difficult to analyze EDR image data.

In such cases, use S-Shift/C-Shift or FIX MODE.

3 The EDR performs processing for the image area trimmed by the DR system.

When using lead characters or metals for measurement, place them inside the radiation field, and then make an exposure.

4 Precautions when using AUTO MODE.

Auto mode	Precautions
I	As this mode is available for extracting information on the skin, secure the positioning so that the direct X-rays are incident to an area other than the target.
II	No special precautions.
III	Be sure to use a Ba contrast medium.
IV	1 Be sure to secure the positioning so that the X-rays are incident to the area directly outside the target. 2 As the reading latitude is fixed, it is necessary to control the tube voltage according to the thickness of the target, as usual.
V	As the reading latitude is fixed, it is necessary to control the tube voltage according to the thickness of the target, as usual.
VI	No special precautions.
VII	No special precautions.

Z.2 Precautions for Exposure in SEMI-AUTO MODE

These precautions are common to Semi I, II, III and III(**).

- 1 Position the portion you need to display often in the center areas (10cm × 10cm (Semi I), 7cm × 7cm (Semi II), 5cm × 5cm (Semi III)) of the images trimmed by the DR system.

Position the portion you need to display often in each of the 5cm × 5cm center areas of the half-split images (both upper and lower halves and right and left halves) and quarter-split image trimmed by the DR system.

- 2 Never position anything other than the subject in the aforementioned areas. If anything other than the subject is positioned in such areas, the image density will become lower.

In addition, do not position any metals or artificial bones in such areas. The image density will become higher if such objects are positioned in these areas.

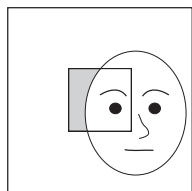

(×)

- 3 It is necessary to control tube voltage according to subject thickness, as usual. The following precautions should be observed for Semi IV.

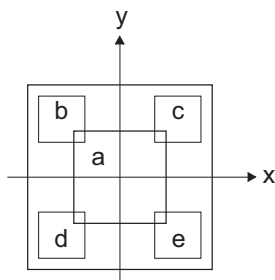

Area	Center Coordinate (x:y) cm	Size (cm)
a	(0, 0)	10×10
b	(-5, 7)	6×6
c	(5, 7)	6×6
d	(-5, -7)	6×6
e	(5, -7)	6×6

- (1) Do not position transparent portions (areas other than the subject) in the aforementioned five areas.

- (2) It is necessary to control tube voltage according to subject thickness, as usual.

- For details of the menus preset in SEMI-AUTO MODE, see the “DR-ID 300CL Operation Manual” and “DR-ID 300CL Image Processing Parameters Operation Manual”.

Z.3 Precautions for Exposure in SEMI-X MODE

The user will select one of the nine areas of the image trimmed by the DR system, on which SEMI-AUTO MODE applies. (See the illustration below.)

The same precautions as for SEMI-AUTO MODE apply.

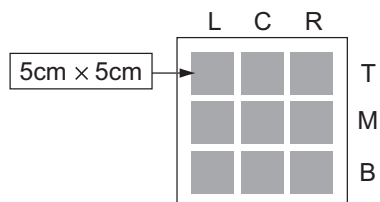

Z.4 Precautions for Exposure in FIX MODE

As reading conditions are fixed, exposure conditions must be controlled in the same way as for conventional X-ray exposure.

The reading conditions (sensitivity and latitude) have been preset according to the relevant menu in FIX MODE. Select the exposure conditions which correspond to that menu accordingly.

Z.5 Other Precautions

Z.5.1 Precautions for Exposure of a Subject in Relatively Large Contrast

- 1 Exposures using a contrast medium may cause artifacts around it.
- 2 When exposing a subject with any metal objects implanted, artifacts may appear around them.
- 3 For exposures with objects of large X-ray absorption, such as lead characters and metals for measurement, artifacts may appear around them. Place such objects outside a subject.

Z.5.2 Precautions for DR System

Generally, when performing a high sensitivity exposure shortly after an exposure that the flat panel sensor excessively receives direct X-ray, the output image may contain image lags of the previous exposure. This phenomenon rarely occurs and does not occur insofar as normal sensitivity exposures are performed.

Exposures at longer intervals can reduce occurrences of this phenomenon. Also observe precautions as follows.

- Continuous high sensitivity exposures to vertebral body part (chest/lumbar spine) should be performed at longer intervals than normal exposures.
- A high sensitivity exposure shortly after a high-dose exposure should be performed at sufficiently long interval.
- When performing high-dose exposures repeatedly, do not use collimation of the radiation field, lead characters or metals for measurement at the same position.

Z.5.3 Precautions for Assuring the Radiation Field



CAUTIONS

It is important to read the following before using the FDR D-EVO digital detector clinically.

The FDR D-EVO is a digital X-ray detector designed for use both within and outside of a standard radiographic bucky. The FDR D-EVO may be exposed to any field size up to and including 14" × 17" (35 × 43cm). FDR D-EVO may be used in any situation where a film cassette may be used. The collimator will open to the full 14" × 17" (35 × 43cm) size when the FDR D-EVO cassette is inserted in the bucky tray of X-ray systems with positive beam limitation (PBL).

Follow the X-ray system manufacturer's instructions to assure the indicated field size matches and does not exceed the actual radiation field size for the available range of SIDs.

Z.5.4 Precautions Related to the X-ray Exposure Time

The X-ray exposure time can be set within the range of 500msec to 3800msec at the time of installation.

Z.5.5 Images Output When the X-ray Shot Switch is Operated Incorrectly

In case that you press the X-ray shot switch only momentarily after selecting exposure menus, sufficient X-ray dose may not be achieved. The output image contains image lags of the previous exposure occasionally.

If this happens, select exposure menus again, and then make an exposure.

Z.5.6 Precautions for Urgent Use

When you start a study before completion of the calibration at the time of startup, the operation will be in Urgent Use Mode. “Urgent Use is possible” message will appear.

- There is no guarantee that the image taken in Urgent Use Mode can be used for diagnostic purposes. Vertical artifact could appear in the image, if the temperature difference is large from the previous shutdown of the system. Check the image quality before use.
- Move from the Study Screen to the Patient Information Input Screen immediately after exiting Urgent Use Mode, so that the calibration will start over automatically.

Z.5.7 Precautions Related to Continuous Operation

If you plan to continuously run the system for over 24 hours, perform post-operation check, and then restart the system.

Otherwise, calibration will not be performed normally, and image quality cannot be guaranteed as a result.

Z.5.8 Precautions Related to Grid

Depending on the type of the grid used, its stripes may appear in the image after making an exposure. To avoid such moire effects, sway the grid from side to side, or use the Grid Pattern Removal Processing Software in conjunction with the grid with 40 lines.

Appendix O Use of Optional Items

O.1 Optional Items

Name	Description
Remote switch	<p>A switch cable used for temporarily disconnecting the power to the flat panel sensor in order to connect/disconnect its connector while the system is in operation. Up to two remote switches can be connected. Using this switch reduces the time required for normal insertion/removal procedure.</p> <p>➊ For the external view, see “O.2.1 Remote Switch” (page O-2).</p>
Relay cable	<p>A relay cable used for branching the cable for two remote switches, when each of them is attached to the upright-type and bed-type radiographic examination stands.</p> <p>➊ For the external view, see “O.2.2 Relay Cable” (page O-2).</p>
SE storage case	<p>A case used for carrying and storing the flat panel sensor.</p> <p>➊ For the external view and precautions, see “O.3 Using the SE Storage Case” (page O-3).</p>
DAP connector cable	<p>A cable used for connecting a dose-area product (DAP) meter.</p> <p>➊ For the external view and precautions, see “O.4 Using the DAP Connector Cable” (page O-4).</p>
Retaining bracket for MP	<p>A set of an anchor and a fixture, which is used for securing the power supply unit to the floor.</p> <p>➊ For the external view, see “O.5 Using the Retaining bracket for MP” (page O-5).</p>
Connection cable for the flat panel sensor (power supply unit)	<p>A cable that connects the flat panel sensor and the power supply unit. This cable is used for adding the second flat panel sensor, changing over the connection between the flat panel sensors, and other usages.</p>
Connection cable for X-ray equipment (9 cores)	<p>A signal cable that connects the power supply unit and the X-ray equipment (Xcon). Two types are available. Cable length: 5m and 15m</p>
Connection cable for X-ray equipment (3 cores)	<p>A signal cable for high current application, which connects the power supply unit and the X-ray equipment (Xcon). Two types are available. Cable length: 5m and 15m</p>
Communication cable for X-ray equipment and power supply unit (RS232C cable)	<p>A communication cable that connects the power supply unit and the X-ray equipment (Xcon). This cable is used for setting the tube voltage and mAs via communication. Four types are available. Cable length: 5m, 9 pins Cable length: 15m, 9 pins Cable length: 5m, 25 pins Cable length: 15m, 25 pins</p>
Relay unit for AC bucky	<p>A relay unit consisting of the relay and terminal block for the AC bucky. Four types are available: For 100V, 120V, 200V, and 220V</p>
Magnetic clamp for flat panel sensor cable	<p>A clamp for fixing the SE cable to the radiographic examination stand, etc.</p>
Cassette holder	<p>A cassette holder attached to the flat panel sensor for improving the load bearing capacity of the flat panel sensor when making an exposure directly with it.</p>
Battery pack	<p>A battery pack for the flat panel sensor (DR-ID 601SE) used in wireless communication mode.</p>
Battery charger	<p>A battery charger for the battery pack.</p>

O.2 Using the Remote Switch

O.2.1 Remote Switch

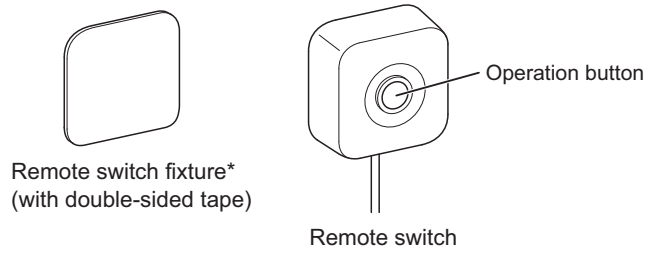

* This metal fixture is used when the remote switch cannot be attached to a wall, etc. with the magnet on the back. The remote switch fixture is attached to a wall, etc. with double-sided tape.

O.2.2 Relay Cable

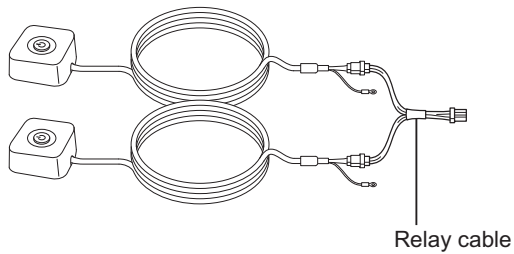

O.3 Using the SE Storage Case

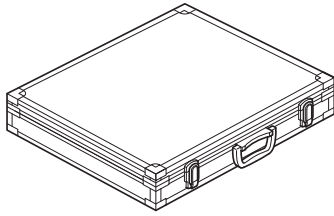

SE storage case

When storing the flat panel sensor in the SE storage case, place it with the exposure plane down. Note also that the storage method varies depending on the direction of the flat panel sensor connector.

For details, see the illustrations below.

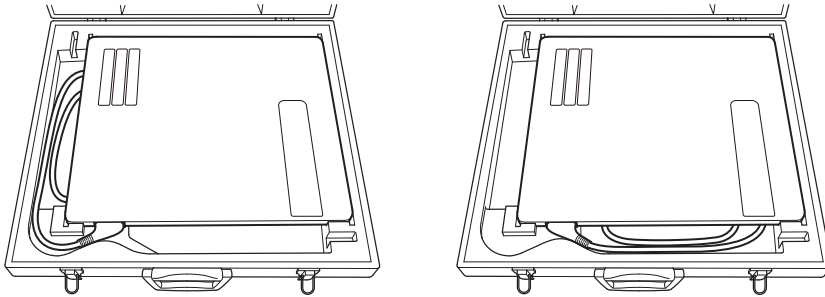

CAUTIONS

- Do not store the SE storage case in a location with the following conditions.
 - Where the SE storage case is exposed to direct sunlight.
 - Where the temperature and humidity change dramatically.
 - Where there is excessive dust.
 - Where chemicals are stored.
 - Where the SE storage case may be exposed to water due to water leakage or ingress.
- Do not connect the flat panel sensor to the connector while it is stored in the SE storage case.
- Do not store anything other than the flat panel sensor in the SE storage case.
- Carefully carry the SE storage case when the flat panel sensor is inside.
If the SE storage case is dropped or is subject to an impact, it may be damaged.
- Do not open/close the SE storage case in a location where there is excessive dust or dirt.
- Do not put the SE storage case on an unstable place. If it falls or drops, personal injury may result.

O.4 Using the DAP Connector Cable

The DAP connector cable is used for connecting a dose-area product (DAP) meter*1 to the power supply unit.

This cable is connected to a dose-area product meter via an RS232C insulator*2.

To connect a DAP meter, contact a FUJIFILM dealer.

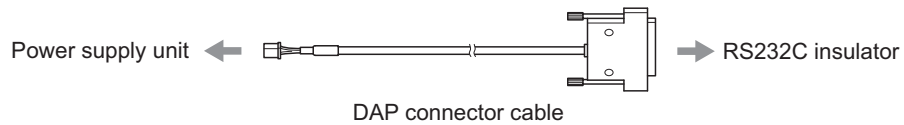

*1 A DAP meter of which FUJIFILM Corporation has confirmed the operational performance is VacuDAP Standard of VacuTec Meßtechnik GmbH.

*2 An RS232C insulator which FUJIFILM Corporation has experience in using is Model 88004 of Wiesemann & Theis GmbH.



- **Thoroughly read the operation manual of a DAP meter to use it correctly.**
- **Make sure that the initial value is “0” before starting measurements. If not, set it to “0” according to the operation manual for the DAP meter.**

O.5 Using the Retaining Bracket for MP

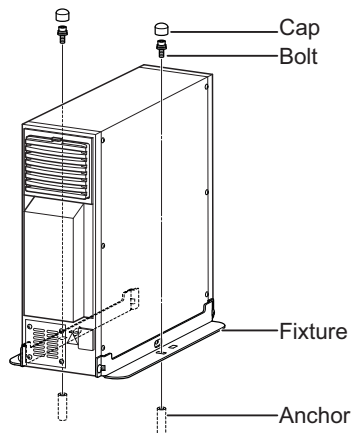

Contact a FUJIFILM dealer for installation of the Retaining bracket for MP.

Maintenance and Inspection

1 Maintenance and Inspection Items Assigned to Specified Dealer

For periodical inspection of the equipment and necessary arrangements, consult our official dealer or local representative.

Periodical Maintenance

Make sure that the periodical maintenance and inspection assigned to our official dealer are performed as specified.

Maintenance and Inspection Items Assigned to Specified Dealer

Periodical Maintenance and Inspection Items	Period
Checking of the image	Every year
Checking of the operation record by referring to the error log	Every year
Checking of the internal units	Every 2 years

Main Periodical Replacement Parts

Name of Periodical Replacement Parts	Period
Relay (optional)	Every 1.5 years (Number of exposures : 90,000)

* It is recommended that the battery pack (optional) be replaced once a year.
If the duration of use exceeds one year, the capacity of the battery pack will decrease.

The cycles of periodical maintenance and inspection and of parts replacement differ depending on the usage and the daily operation time.

For details, contact us directly or our official dealer.

This device complies with Part 15 of FCC Rules and RSS-Gen of IC Rules. Operation is subject to the following two conditions:

(1) this device may not cause interference, and (2) this device must accept any interference, including interference that may cause undesired operation of this device.

FCC WARNING

Changes or modifications not expressly approved by the party responsible for compliance could void the user's authority to operate the equipment.

Note : This equipment has been tested and found to comply with the limits for a Class B digital device, pursuant to part 15 of the FCC Rules. These limits are designed to provide reasonable protection against harmful interference in a residential installation. This equipment generates, uses and can radiate radio frequency energy and, if not installed and used in accordance with the instructions, may cause harmful interference to radio communications. However, there is no guarantee that interference will not occur in a particular installation.

If this equipment does cause harmful interference to radio or television reception, which can be determined by turning the equipment off and on, the user is encouraged to try to correct the interference by one or more of the following measures:

- Reorient or relocate the receiving antenna.
- Increase the separation between the equipment and receiver.
- Connect the equipment into an outlet on a circuit different from that to which the receiver is connected.
- Consult the dealer or an experienced radio/TV technician for help.

The available scientific evidence does not show that any health problems are associated with using low power wireless devices.

There is no proof, however, that these low power wireless devices are absolutely safe. Low power Wireless devices emit low levels of radio frequency energy (RF) in the microwave range while being used. Whereas high levels of RF can produce health effects (by heating tissue), exposure of low-level RF that does not produce heating effects causes no known adverse health effects. Many studies of low-level RF exposures have not found any biological effects.

Some studies have suggested that some biological effects might occur, but such findings have not been confirmed by additional research. DR-ID600 has been tested and found to comply with FCC/ IC radiation exposure limits set forth for an uncontrolled environment and meets the FCC radio frequency (RF) Exposure Guidelines in Supplement C to OET65 and RSS-102 of the IC radio frequency (RF) Exposure rules.

5.15-5.25GHz band is restricted to indoor operations only.

Compliance with FCC requirement 15.407[®] Data transmission is always initiated by software, which is the passed down through the MAC, through the digital and analog baseband, and finally to the RF chip. Several special packets are initiated by the MAC. These are the only ways the digital baseband portion will turn on the RF transmitter, which it then turns off at the end of the packet. Therefore, the transmitter will be on only while one of the aforementioned packets is being transmitted.

In other words, this device automatically discontinues transmission in case of either absence of information to transmitter or operational failure.

(This transmitter must not be co-located or operated in conjunction with any other antenna or transmitter.)

FUJIFILM



Manufacturer :

FUJIFILM Corporation

26-30, NISHIAZABU 2-CHOME, MINATO-KU, TOKYO 106-8620, JAPAN



0123



European Authorized Representative:

FUJIFILM Europe GmbH

Heesenstrasse 31, 40549 Duesseldorf, Germany

FUJIFILM MEDICAL SYSTEMS U.S.A., INC.

419 WEST AVENUE, STAMFORD CT 06902, U.S.A.