

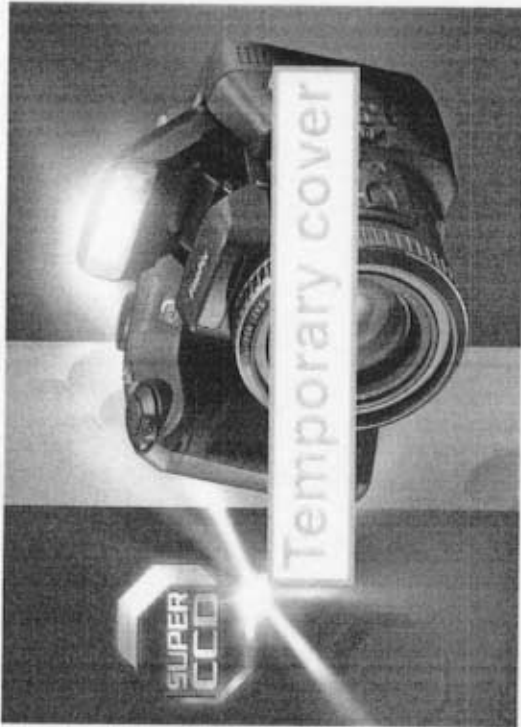

DIGITAL CAMERA
FinePix S2 Pro



Getting Ready

Basic
Photography

Advanced
Photography

Advanced
Features
Playback

Setup

Connection

OWNER'S MANUAL

This manual will show you how to use your FUJIFILM DIGITAL CAMERA FinePix S2 Pro correctly. Please follow the instructions carefully.

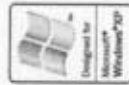

BL00140-200(1) **E**

Warning

To prevent fire or shock hazard, do not expose the unit to rain or moisture.

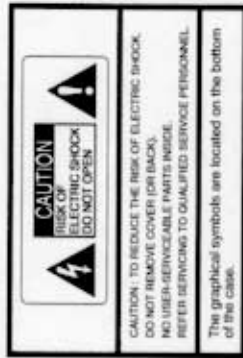

CAUTION

This equipment has been tested and found to comply with the limits for a Class B digital device, pursuant to Part 15 of the FCC Rules. These limits are designed to provide reasonable protection against harmful interference in a residential installation. This equipment generates, uses, and can radiate radio frequency energy and, if not installed and used in accordance with the instructions, may cause harmful interference to radio communications. However, there is no guarantee that interference will not occur in a particular installation. If this equipment does cause harmful interference to radio or television reception, which can be determined by turning the equipment off and on, the user is encouraged to try to correct the interference by one or more of the following measures:

- Reorient or relocate the receiving antenna.
 - Increase the separation between the equipment and receiver.
 - Connect the equipment into an outlet on a circuit different from that to which the receiver is connected.
 - Consult the dealer or an experienced radio/TV technician for help.
- You are cautioned that any changes or modifications not expressly approved in this manual could void the user's authority to operate the equipment.

Notes on the Grant:

To comply with Part 15 of the FCC rules, this product must be used with a Fujifilm-specified ferrite-core video cable, USB cable, IEEE1394 cable and DC supply cord.

For customers in Canada

CAUTION

This Class B digital apparatus complies with Canadian ICES-003.

Please read the Safety Notes (P.123) and make sure you understand them before using the camera.

EC Declaration of Conformity

We Name : Fuji Photo Film (Europe) G.m.b.H.
Address : Heesenstrasse 31
40549 Düsseldorf, Germany

declare that the product
Product Name : FUJIFILM DIGITAL CAMERA FinePix S2 Pro
Manufacturer's Name : Fuji Photo Film Co., Ltd.
Manufacturer's Address : 26-30, Nishiazabu 2-chome, Minato-ku,
Tokyo 106-8620, Japan

is in conformity with the following Standards

Safety : EN60065
EMC : EN55022 : 1998 Classe B
EN55024 : 1998
EN61000-3-2 : 1995 + A1:1998 + A2:1998

following the provision of the EMC Directive (89/336/EEC, 92/31/EEC and 93/68/EEC) and Low Voltage Directive (73/23/EEC)



Düsseldorf, Germany, June 1, 2002

Place

Date

Signature/Managing Director



Bij dit produkt zijn batterijen geleverd. Wanneer deze leeg zijn, moet u ze niet weggooien maar inleveren als KCA

For customers in the U.S.A.

FCC Statement

This device complies with part 15 of the FCC Rules. Operation is subject to the following two conditions: (1) This device may not cause harmful interference, and (2) this device must accept any interference received, including interference that may cause undesired operation.

Preface

- **Test Shots Prior to Photography**
For particularly important photographs (such as weddings and overseas trips), always take a test photograph and view the image to make sure that the camera is functioning normally.
- **Fuji Photo Film Co., Ltd. cannot accept liability for any incidental losses (such as the costs of photography) or the loss of income from photography) incurred as a result of faults with this product.**

- **Notes on Copyright**
Images recorded using your digital camera system cannot be used in ways that infringe copyright laws without the consent of the owner, unless intended only for personal use. Note that some restrictions apply to the photographing of stage performances, entertainments and exhibits, even when intended purely for personal use. Users are also asked to note that the transfer of memory cards (SmartMedia or Microdrive) containing images or data protected under copyright laws is only permissible within the restrictions imposed by those copyright laws.

- **Liquid Crystal**
If the LCD monitor is damaged, take particular care with the liquid crystal in the monitor or finder. If any of the following situations arise, take the urgent action indicated.
 - If liquid crystal comes in contact with your skin: Wipe the area with a cloth and then wash thoroughly with soap and running water.
 - If liquid crystal gets into your eye: Flush the affected eye with clean water for at least 15 minutes and then seek medical assistance.
 - If liquid crystal is swallowed: Flush your mouth thoroughly with water. Drink large quantities of water and induce vomiting. Then seek medical assistance.

- **Notes on Electrical Interference**
If the camera is to be used in hospitals or aircraft, please note that this camera may cause interference to other equipment in the hospital or aircraft. For details, please check with the applicable regulations.

- **Handling Your Digital Camera**
This camera contains precision electronic components. To ensure that images are recorded correctly, do not subject the camera to impact or shock while an image is being recorded.

- **Trademark Information**
Mac and Macintosh are registered trademarks of Apple Computer, Inc.
Microsoft, Windows, and the Windows logo are trademarks, or registered trademarks of Microsoft Corporation in the United States and/or other countries. Windows is an abbreviated term referring to the Microsoft Windows Operating System.
● The "Designed for Microsoft Windows XP" logo refers to the camera and the driver only.
● SmartMedia is a trademark of Toshiba Corporation.
● CompactFlash is a trademark of Sandisk Corporation of the U.S.
● Microdrive is a trademark of the International Business Machines Corporation of the U.S.
● Other company or product names are trademarks or registered trademarks of the respective companies.

- **Explanation of Color Television System**
NTSC: National Television System Committee, color television telecasting specifications adopted mainly in the U.S.A., Canada and Japan.
PAL: Phase Alternation by Line, a color television system adopted mainly by European countries and China.

- **Exif Print (Exif ver. 2.2)**
Exif Print Format is a newly revised digital camera file format that contains a variety of shooting information for optimal printing.

◆ LCD cover ◆







To prevent soiling or damage to the LCD monitor, attach the enclosed LCD cover to the camera when you are carrying or not using the camera. Attach the LCD cover by fitting it into the grooves to the right of the LCD monitor.

Camera Features and Accessories

Features

- The newly developed large-size "Super CCD Honeycomb" built into the FinePix S2 Pro provides an ultra-high resolution, high sensitivity, a large dynamic range and an excellent SN ratio.
- 6.17 million effective image pixels
- Over 12 million recorded image pixels (4256 x 2848 pixels)
- Supports uncompressed data output for CCD-RAW data
- Wide range of sensitivity settings from ISO 100 to ISO 1600
- Multifunctionality built in to meet the needs of professionals
 - 5-part metering AF function
 - Shutter speeds from 30 sec to 1/4000 sec.
 - Equipped with a synchronizing terminal
 - Quick, responsive operation with only 0.5 seconds between shots.
 - Dual slot for SmartMedia and Microdrives

Accessories

- **Lithium Batteries CR123A (2)**
- **AA-size Alkaline Batteries (4)**
- **Strap (1)**
- **Video Cable (approx. 1.5 m (4.9ft.), mini-plug (3.5 mm-dia.) to pin-plug cable) (1)**
- **Accessory shoe cover**
- **Camera Body Cap (1)**
- **LCD Cover (1)**
- **Eyepiece Cap (1)**
- **Interface Set (1)**
 - CD-ROM: Software for FinePix EX (1)
Photoshop Element (1)
 - IEEE1394 4-pin to 6-pin cable (1)
 - Special USB cable with Noise Suppression core (1)
 - Software Quick Start Guide (1)
- **Owner's Manual (this manual) (1)**

Contents

Warning	2
EC Declaration of Conformity	3
Preface	4
Camera Features and Accessories	5
Nomenclature	9
Top display panel	12
LCD monitor	12
Rear display panel	13
Viewfinder display	14

1 Getting Ready	15
ATTACHING THE SHOULDER STRAP	15
MOUNTING THE CAMERA LENS	16
Using Nikon lenses with built-in CPUs other than G-type lenses	17
Lens Compatibility	18
LOADING THE MEDIA	20
SmartMedia™ (optional)	20
Microdrive (optional, supplied by another manufacturer)	20
LOADING THE BATTERIES	22
Compatible Batteries	22
Loading the lithium batteries	22
Loading the AA-size batteries	23
SWITCHING ON AND OFF • SETTING THE DATE AND TIME	24
CHECKING THE BATTERY LEVEL	25
■ When you have difficulty obtaining lithium batteries	25
■ Batteries Uses and Symptoms When Batteries are Depleted	25

2 Basic Photography	26
BASIC OPERATION GUIDE	26
Command dials	29
TAKING PICTURES	30
NUMBER OF AVAILABLE SHOTS	32
■ Standard Number of Shots for the Media	32
USING AF LOCK	33
PLAYING BACK IMAGES	34
DIOPTRIC ADJUSTMENT/LCD ILLUMINATOR	35
DEPTH OF FIELD CHECK BUTTON/CCD PLANE INDICATOR	36

3 Advanced Photography	37
FOCUS SETTINGS	37
■ Focus-related custom settings	37
SELECTING THE FOCUS MODE	38
■ Focus modes	38
SELECTING THE AF AREA MODE	39
Selecting the focus area	40
AF-ASSIST ILLUMINATOR	41
SITUATIONS WHERE AUTOFOCUS MAY NOT WORK AS EXPECTED	42
MANUAL FOCUS	43
Focus can be set manually when the focus mode selector is set to M.	43
Focus Aid	43
RELEASE MODES/[S] (SINGLE-FRAME) AND [C] (CONTINUOUS SHOOTING)	44
[S] (Single frame)	44
[C] (Continuous Shooting)	44

METERING SYSTEMS	45
■ Matrix (10-segment) metering	45
■ Center-weighted metering	45
■ Spot metering	45
ISO SENSITIVITY/EXPOSURE MODES P	46
Program chart	47
EXPOSURE MODES S	48
S SHUTTER-PRIORITY AUTO	48
EXPOSURE MODES A	49
A APERTURE-PRIORITY AUTO	49
EXPOSURE MODES M	50
M MANUAL	50
Bulb Photography ("bulb")	52
TAKING PICTURES WITH AE LOCK	53
■ EXPOSURE COMPENSATION	54
■ AUTO EXPOSURE BRACKETING	55
■ MULTIPLE EXPOSURE	57
SELF-TIMER PHOTOGRAPHY	59
FLASH PHOTOGRAPHY	60
SETTINGS FOR FLASH PHOTOGRAPHY	60
BUILT-IN FLASH	61
■ Flash control modes that can be used with the built-in flash	61
SYNCHRO MODES AND THEIR FEATURES	62
■ FRONT SYNCHRO MODE	62
■ SLOW SLOW SYNCHRO	62
■ REAR REAR SYNCHRO	63
■ RED-EYE REDUCTION MODE	63
■ SLOW RED-EYE REDUCTION SLOW SYNCHRO MODE	63
■ Shutter Speeds	63
TAKING PICTURES USING THE BUILT-IN FLASH	64
■ Effective Range of the Built-in Flash	65
LENSES THAT CAN BE USED WITH THE BUILT-IN FLASH	66
FLASH EXPOSURE COMPENSATION	67
To check the amount of compensation	67
To cancel exposure compensation	67
NIKON FLASH UNITS THAT CAN BE USED	68
USING THE FUNCTION MENU WHEN TAKING PICTURES	70
■ WHITE BALANCE	71
■ AF AREA/QUALITY/RECORDED PIXELS	72
AF AREA	72
QUALITY	73
RECORDED PIXELS	73
■ COLOR/TONE/SHARPNESS/FUNCTION LOCK	74
COLOR	74
TONE	74
SHARPNESS	75
FUNCTION LOCK	75

Advanced Photography

1

2

3

4

5

6

Contents

USING THE FUNCTION MENU	76
■ HISTOGRAM	77
■ About the Histogram Display	77
■ ERASING SINGLE-FRAME	78
■ SINGLE-FRAME PROTECT	79
■ To check protected frames	79
■ MULTI-FRAME PLAYBACK	80
■ PLAYBACK MENU	81
■ ERASE	81
○ SETTING AND REMOVING PROTECTION FOR ALL FRAMES	83
HOW TO SPECIFY PRINT OPTIONS (DPOF)	84
■ VOICE MEMO (AUDIO RECORDING)	86
LCD BRIGHTNESS	88
SET-UP	89
■ SET-UP Menu Options	89
Setup operations	89
IMAGE DISPLAY	90
Using the Preview Function	90
SETTING THE CUSTOM WB	91
■ When the exposure is not measured correctly	92
VOICE MEMO	93
FRAME No. MEMORY	94
TWO-BUTTON RESET	95
CUSTOM SETTING (CSM)	96
Cancelling custom settings	96
■ Custom Settings List	97
CONNECTING TO A TV/USING THE AC POWER ADAPTER (OPTIONAL)	99
CONNECTING TO A COMPUTER	100
CONNECTING TO A COMPUTER VIA IEEE 1394	101
CONNECTING TO A COMPUTER VIA USB	102
DISCONNECTING FROM THE PC (Important — always use this procedure.)	103

4 Advanced Features Playback

5 Setup

6 Connection

System Expansion Options	104
Accessories Guide	105
Notes on Using Your Camera Correctly	107
Cleaning the CCD	108
Notes on the Power Supply	112
Applicable Batteries	112
Notes on the Batteries	112
Notes on Using the AC Power Adapter	112
Notes on the Media (SmartMedia™ and Microdrives)	113
Warning Displays	114
Troubleshooting	118
Specifications	120
Explanation of Terms	122
Safety Notes	123

Nomenclature

* Refer to the pages in parentheses for information on using the camera features.

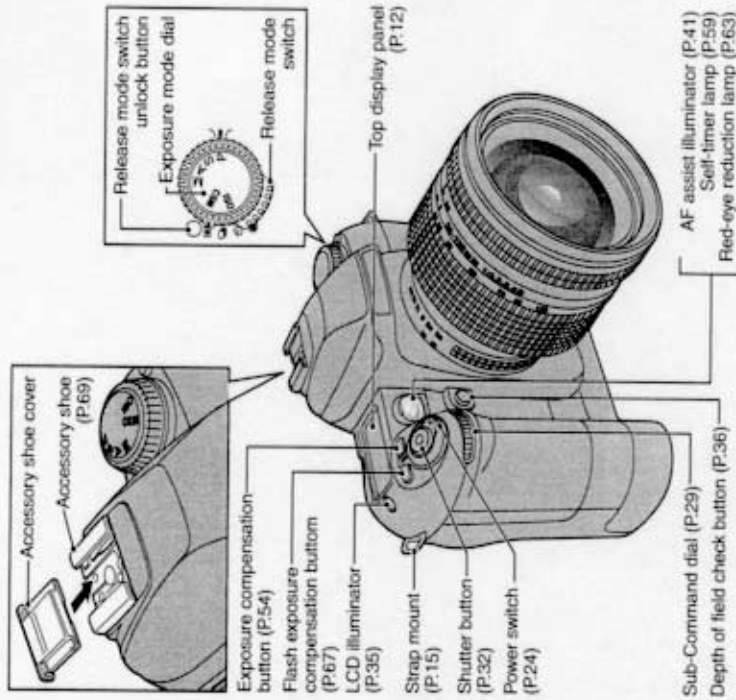

Nomenclature

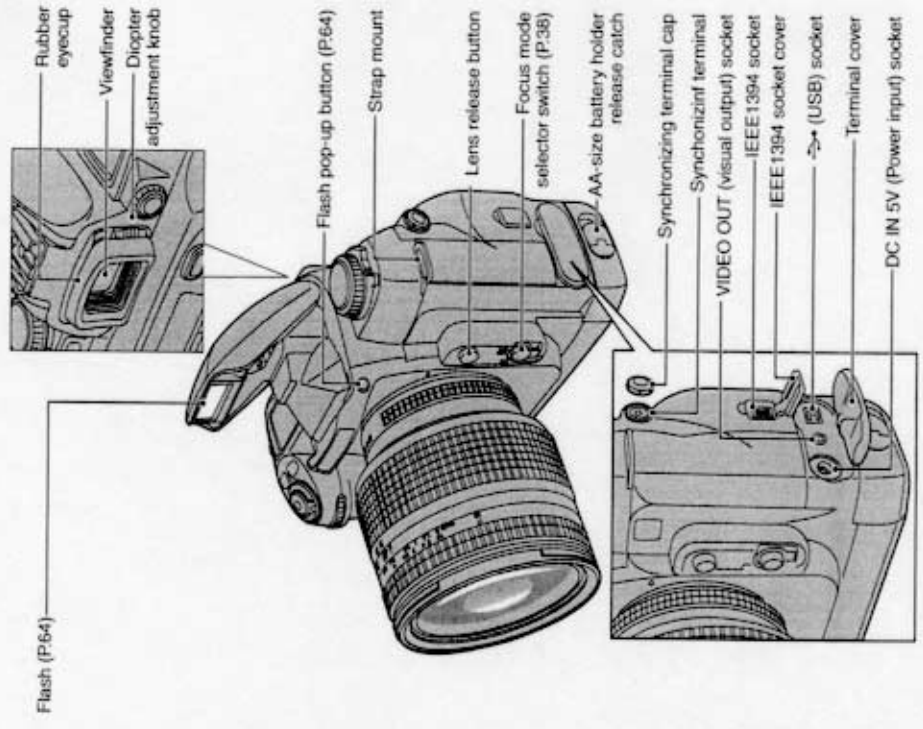
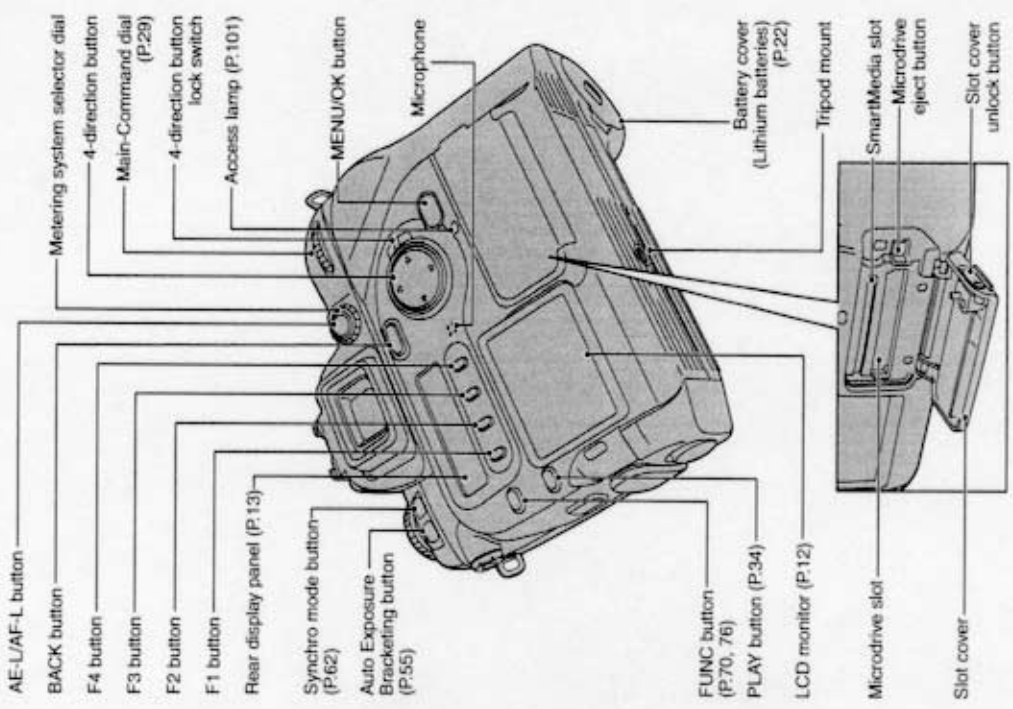

Nomenclature

Top display panel

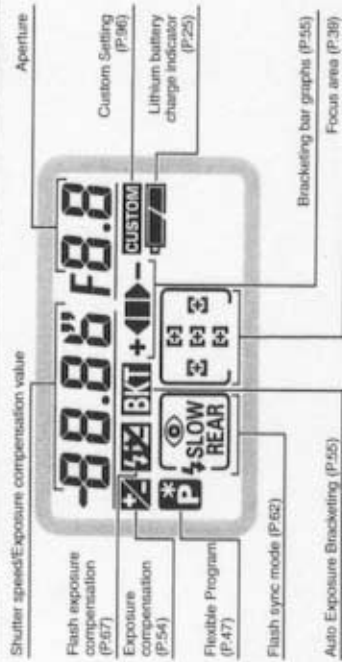

The LCD used in the top display panel will turn dark at high temperatures and will respond a little more slowly at low temperatures. However, it will operate normally again at normal temperatures.

LCD monitor

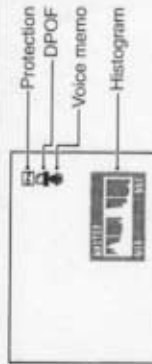

There may be some unevenness in the brightness at the bottom of the LCD monitor. This is due to variations in the lighting of the LCD itself and is not a fault.

Rear display panel

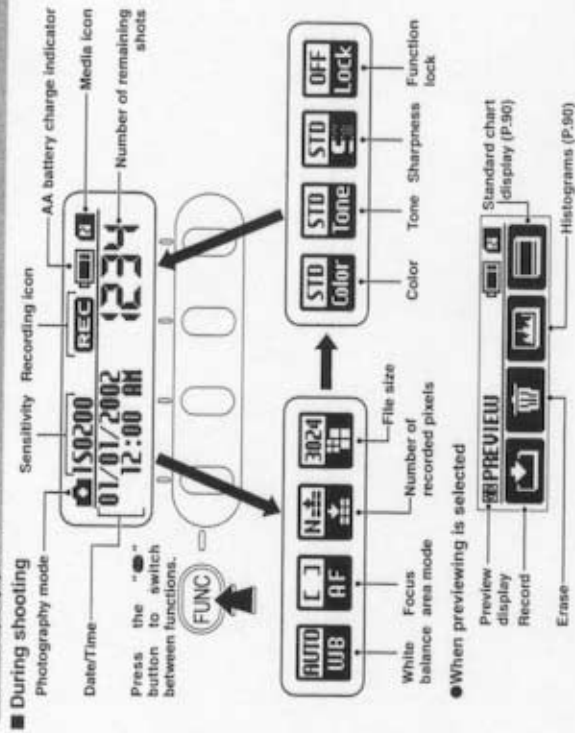

When previewing is selected

During playback

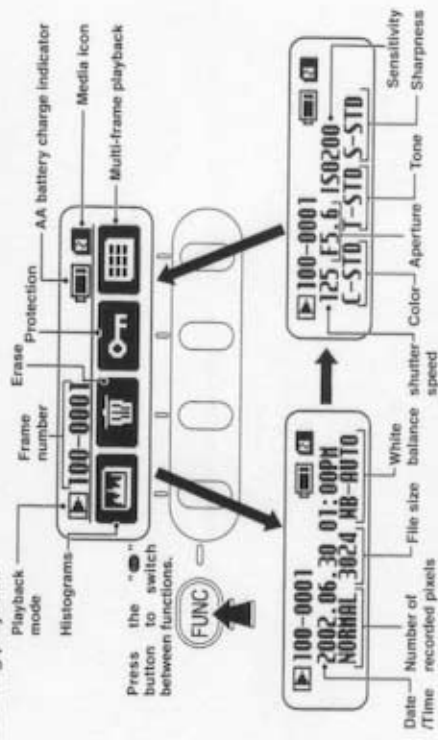

The LCD used in the rear display panel will turn dark at high temperatures and will respond a little more slowly at low temperatures. However, it will operate normally again at normal temperatures.

For CCD-RAW images, the frame number is highlighted.

Nomenclature

Viewfinder display

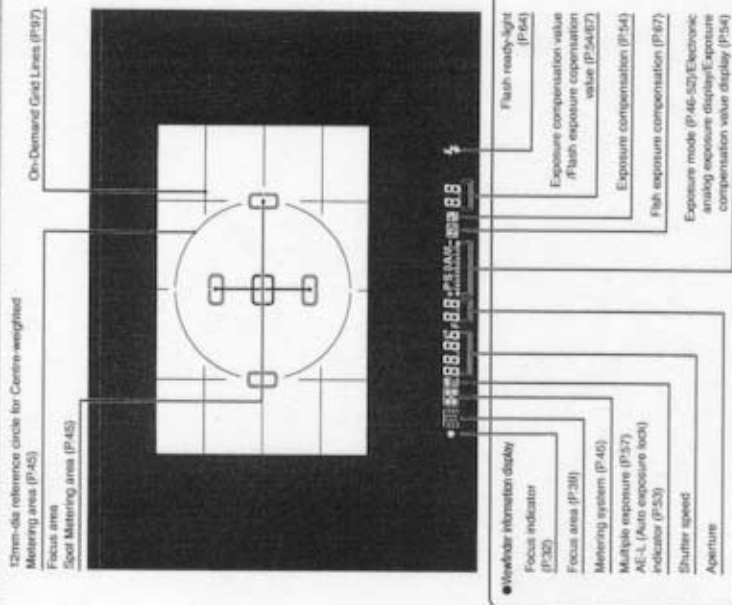

⚠ The viewfinder will be dark without Lithium battery power but brightens after installation of fresh batteries. This is not a malfunction.

⚠ The LCD panel in the upper part of the viewfinder (focus area and framing guides) will become paler at high temperatures and will become darker and respond a little more slowly at low temperatures. However, it will operate normally again at normal temperatures.

⚠ The LCD panel in the viewfinder display (where the icons and numbers are displayed) will turn dark at high temperatures and will respond a little more slowly at low temperatures. However, it will operate normally again at normal temperatures.

◆ About Advanced Focusing Screen Display

The new Advanced Focusing Screen Display of the FinePix S2 Pro employs the convenient Vari-Brite Focus Area display system; it enables clear display of the focus brackets at the selected focus area in the viewfinder for easy identification. When the finder image is bright, the focus brackets are displayed in black and when the finder image is dark, the focus brackets are momentarily illuminated in red. The selected focus area can be identified easily in both bright and dark conditions with this function. Also, the new Advanced Focusing Screen Display allows the superimposition of On-Demand Grid Lines. The grid lines can be displayed by using Custom Setting menu #2 (P.56). These grids assist you in composing the frame, in taking landscape pictures or in shifting/tilting PC-Nikkor lenses.

⚠ Due to characteristics of the LCD used in the Vari-Brite Focus Area display system, a thin line outside the selected focus area may also be displayed or the entire viewfinder may be illuminated in red under certain conditions. These are not malfunctions.

1 Getting Ready

ATTACHING THE SHOULDER STRAP

Pass one end of the strap through the strap mount on the camera body.

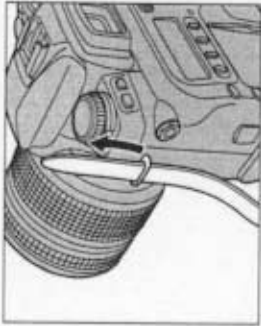

1

1 Getting Ready

Pass the end of the strap through the fastener (A) and (B) as shown in the figure.

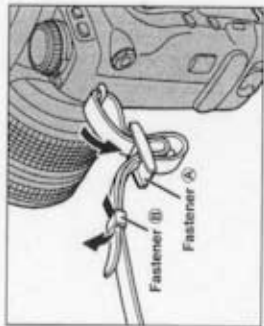

2

Adjust the strap length. Use the same procedure to attach the other end of the strap to the other strap mount.

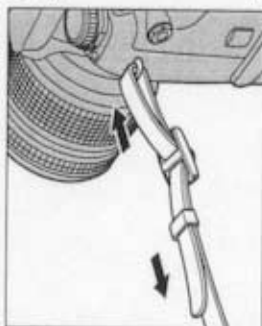

3

⚠ Check that the strap is pulled tight after it is attached.

MOUNTING THE CAMERA LENS

1 Check the lens type.



CPU contacts of CPU lens.
The lens is fitted with CPU signal contacts.

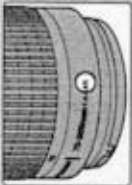

G-type Nikkor lens.
(without aperture ring)



CPU Nikkor lens other than G-type
(with aperture ring)

See "Lenses that can be used with this camera" (p. 11) for details.

2

Set the power switch to OFF to switch the camera off.

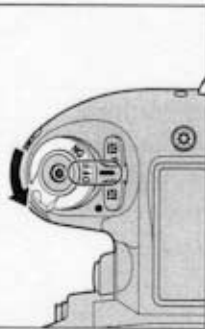

3

Position lens in the camera's bayonet mount so that the mounting indexes on lens and camera body are aligned, then twist lens counterclockwise until it locks into place.

- Take care not to mount the lens when it is at an angle to the camera as this can damage the lens mount on the camera.
- Always change the lens in an area free of dirt and dust.
- When attaching the lens, take care not to press the lens release button.
- When the lens is not attached or when a non-CPU Nikkor lens is attached and the power switch is turned on, "y..." blinks in the top display panel and viewfinder, and the shutter cannot be released. See page 00 for a non-CPU lens.



Using Nikkor lenses with built-in CPUs other than G-type lenses

Set the aperture ring to the smallest aperture.

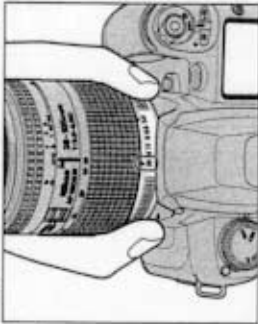

1

Getting Ready

Lock the aperture ring. If you switch the camera on without first selecting the smallest aperture (the aperture setting with the highest number), "FE E" flashes on the top display panel and in the viewfinder, and the shutter will not operate.

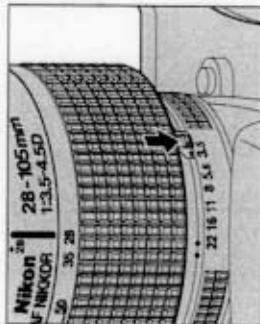

2

Removing the lens

Push and hold the lens release button, then turn the lens clockwise.



While the lens is removed from the camera, fit the camera body cap provided onto the camera to protect the inside of the camera and prevent soiling of the mirror and viewfinder screen. (You can also use the Nikon BF-1A Body Cap.)



MOUNTING THE CAMERA LENS

Lens Compatibility

Use a CPU lens (except IX-Nikkor) with this camera. D- or G-type AF lenses give you access to all available functions. See page 16.

Types of CPU lenses and other usable lenses/accessories

Lens/accessories	Mode		Focus mode		Exposure mode		Metering system	
	Autofocus	Manual with electronic rangefinder	Manual	Any mode other than M	M	3D 1D-segment	1D-segment	Centre-Weighted Spot**
D-type AF Nikkor** G-type AF Nikkor, AF-S, AF-I Nikkor PC Micro-Nikkor 85 mm f/2.8D** CPU Nikkor	○	○	○	○	○	○	○	○
AF-I Teleconverter**	○*	○*	○	○	○	○	○	○
Non-D/G-type AF Nikkor (except AF Nikkor for F3AF)	○	○	○	○	○	○	○	○
Ai-P Nikkor	—	○**	○	○	○	○	○	○
Ai-S or Ai type Nikkor Semi-E, Ai-modified Nikkor	—	○**	○	○	○*	—	—	—
Medical-Nikkor 120 mm f/4	—	○	○	○	○*	—	—	—
Reflex-Nikkor	—	—	○	○	○*	—	—	—
PC-Nikkor	—	○*	○	○	○*	—	—	—
Ai-S or Ai type Teleconverters	—	○*	○	○	○*	—	—	—
Bellows Focusing Attachment PB-6**	—	○*	○	○	○*	—	—	—
Auto Extension Rings (PK-11A, PK-12, PK-13 and PK-11)	—	○*	○	○	○*	—	—	—

- Spot Metering area can be shifted with focus area selector (=P.45) with CPU Nikkor lens.
- IX-Nikkor lenses cannot be attached.
- This camera is compatible with the Vibration Reduction function of the VR Nikkor lens.
- The camera's exposure metering and flash control system do not work properly when shifting and/or tilting the lens, or when using an aperture other than the maximum aperture.
- Without shifting and/or tilting the lens.
- Compatible with AF-S and AF-I Nikkor except AF-S 17-35 mm f/2.8D IF-ED and AF-S 28-70 mm f/2.8D IF-ED.
- With maximum effective aperture of f/5.6 or faster.
- Some lenses/accessories cannot be attached (=P.19).
- With exposure mode set to Manual. The exposure meter cannot be used.
- With exposure mode set to Manual and shutter speed set to 1/125 sec. or slower but the exposure meter cannot be used.
- Attach the PB-6 vertically (PB-6 can be set to horizontal position after attaching).
- AS-15 must be attached in combination with Medical-Nikkor 200 mm f/5.6 for the lens to fire flash.
- Regroscopy Outfit PF-4 can be attached in combination with Camera Holder PA-4.

G-type Nikkor and other CPU Nikkor lens

The G-type Nikkor lens has no aperture ring; aperture should be selected from camera body. Unlike other CPU Nikkor lenses, aperture does not need to be set to minimum (largest f-number).

CPU Nikkor lenses other than G-type Nikkor lens have an aperture ring. Set the lens aperture to its minimum and lock. When the lens is not set to its minimum aperture setting and the power switch is turned on, "FE" blinks in the LCD panel and viewfinder and the shutter cannot be released.

When a non-CPU lens is attached

Set exposure mode to "M" Manual with a non-CPU lens. (When other modes are selected, shutter cannot be released.) The camera's exposure meter cannot be used and the aperture cannot be set using the Sub-Command Dial when using non-CPU lenses. "y-" appears in place of the aperture indication in the top display panel and viewfinder; self-confirm aperture using the lens aperture ring.

The following Nikkor lenses/accessories cannot be attached to the FinePix S2 Pro (otherwise camera body or lens may be damaged):

- TC-16A Teleconverter
- Non-AI lenses
- 400mm f/4.5, 600 mm f/5.6, 800 mm f/8 and 1200 mm f/11 with Focusing Unit AU-1
- Fisheye 6 mm f/5.6, 7.5 mm f/5.6, 8 mm f/8 and CP 10 mm f/5.6
- Old type 21 mm f/4
- K1, K2 ring, Auto Extension Ring PK-1, PK-11, Auto Ring BR-2, BR-4
- ED 150-600 mm f/8 (No. 174041-174180)
- ED 360-1200 mm f/11 (No. 174031-174127)
- 200-600 mm f/5.5 (No. 280001-300490)
- 80 mm f/2.8, 200 mm f/3.5 and TC-16 Teleconverter for F3AF
- PC 28 mm f/4 (No. 180900 or smaller)
- PC 35 mm f/2.8 (No. 851001-906200)
- Old type PC 35 mm f/3.5
- Old type Reflex 1000 mm f/6.3
- Reflex 1000 mm f/11 (No. 142361-143000)
- Reflex 2000 mm f/11 (No. 200111-200310)

LOADING THE MEDIA

You can use either SmartMedia or Microdrive as recording media in the FinePix S2 Pro.

- If you load a SmartMedia and a Microdrive at the same time, images will be recorded onto the media selected as the "Primary media" (see "Settings" P.89).
- Data cannot be copied between the two media types on the FinePix S2 Pro.

SmartMedia™ (optional)

Always use 3.3-volt SmartMedia.

- MG-4S (4MB)
- MG-8S (8MB)
- MG-16S (16MB)
- MG-16SW (16MB, ID)
- MG-32S (32MB)
- MG-32SW (32MB, ID)
- MG-64SW (64MB, ID)
- MG-128SW (128MB, ID)



- Images cannot be recorded or erased if a write-protect sticker is affixed to the SmartMedia.
- Operation of this camera is only guaranteed when it is used with FUJIFILM SmartMedia.
- Some 3.3V SmartMedia are labeled as "3V" or "10" cards.
- See P.112 for more information on using SmartMedia.

Microdrive (optional; supplied by another manufacturer)

- Microdrive 340MB
- Microdrive 1GB



- Microdrives are actually very small and light hard disks. Because they are a spinning storage medium, they are less resistant to vibration and impacts than SmartMedia. If you are using a Microdrive, take great care not to expose the camera to vibration or impacts (particularly during recording or playback).
- The use of Ni-MH (nickel-metal hydride) batteries is recommended when using a Microdrive.
- See P.112 for more information on using Microdrive.

Some CompactFlash® cards may not work properly. Please contact the card manufacturer for compatibility.

Set the power switch to "OFF" and check that the Access lamp is off. Then open the slot cover.

Never open the media slot cover while the camera is switched on. This could destroy the image data or damage the SmartMedia itself.

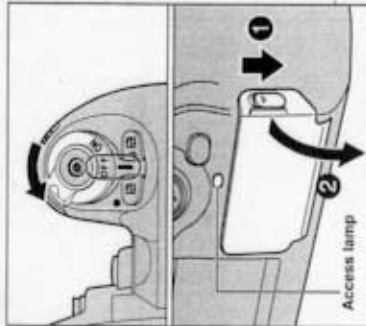

Access lamp

2



Gold marking

Align the contact area (gold-colored section) on the SmartMedia with the gold marker on the SmartMedia slot and push the SmartMedia firmly all the way into the slot.

Then close the battery compartment cover.

- If you open the slot cover while the camera is still switched on, the camera is switched off as a safety measure.
- If the media is oriented incorrectly, it will not go all the way into the slot. Do not apply excessive force when inserting a SmartMedia or Microdrive.

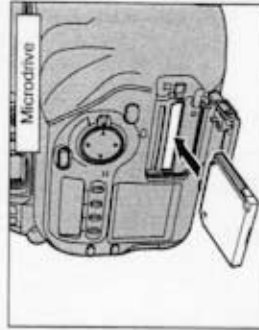

Microdrive

Push the Microdrive firmly all the way into the Microdrive slot.

1

Getting Ready

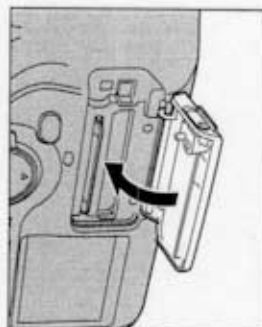

Close the slot cover

Replacing a SmartMedia

Set the power switch to "OFF", check that the Access lamp is off and then open the slot cover. If you push the SmartMedia gently into the slot, it pops out for easy removal.



- When storing SmartMedia, always use the special anti-static case provided.

Replacing a Microdrive

Set the power switch to "OFF", check that the Access lamp is off and then open the slot cover. Then press the eject button and remove the Microdrive.



- When storing Microdrives, always use the special protective case provided.

LOADING THE BATTERIES

Compatible Batteries

- CR123A batteries: 2 (lithium)
- AA batteries: 4 (alkaline or nickel-metal hydride)

About the Batteries

- Never use a battery when the outer casing is split or peeling as this could result in a short-circuit and cause major problems due to battery fluid leakage or overheating.
- Do not use AA-size lithium, manganese or nickel-cadmium (Ni-Cad) batteries.
- Do not use batteries of different types or brands together and do not use new batteries together with used batteries.
- The useful life of alkaline batteries varies depending on the brand. The life of some batteries may be considerably shorter than the batteries supplied with the camera. Due to the nature of alkaline batteries, the time for which they can be used is shorter in cold locations (+10°C (+50°F) or below).
- Soiling such as fingerprints or grease on the poles of batteries can significantly reduce the number of shots that can be taken.
- See P.111 for other precautions concerning the use of batteries.

Outer casing



Loading the lithium batteries



1 Set the power switch to OFF to switch the camera off.



2 Open the battery compartment cover.

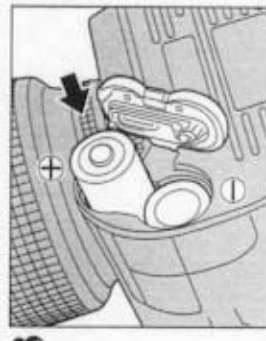

3 Load the lithium batteries in the direction indicated by the ⊕ and ⊖ labels on the camera.

⚠ Do not apply excessive force to the battery cover.

⚠ Take care not to drop the batteries when opening or closing the battery cover.



4 Firmly close the battery compartment cover.

Loading the AA-size batteries



1 Set the power switch to OFF to switch the camera off.

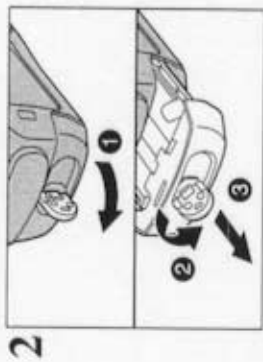

2 Lift out the battery holder lock tab.
3 Turn the battery holder lock tab counterclockwise to unlock the battery holder.
4 Pull the battery holder out.



3 Load the AA-size batteries in the direction indicated by the ⊕ and ⊖ labels on the holder.

⚠ Remove the batteries more easily by pushing the batteries upwards from the gap at the opposite end from the battery holder lock tab.

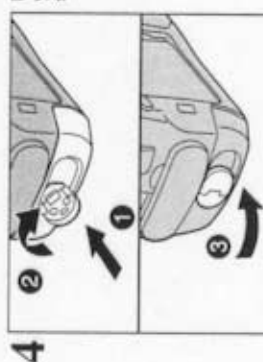

4 Push the battery holder in and hold it in place as you turn the battery holder lock tab clockwise to securely lock the battery holder.

SWITCHING ON AND OFF • SETTING THE DATE AND TIME

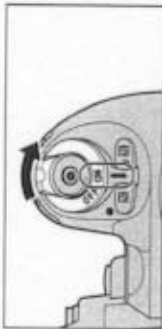

To switch the camera on, set the Power switch to "ON".
To switch the camera off, set the Power switch to "OFF".

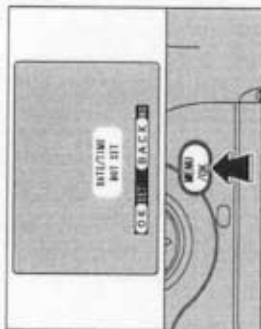

When you first switch the camera on, the date is cleared. Press the "MENU/OK" button to set the date and time.

To set the date and time later, press the "BACK" button.
If you do not set the date and time, the confirmation message will appear each time you switch the camera on.

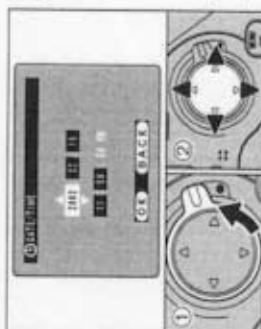

1. Unlock the 4-direction button.
2. Press "▲" or "▶" to select year, month, day, hour or minute and then press "▲" or "▶" to adjust the selected setting.

If you hold down "▲" or "▶", the numbers change continuously.
When the time displayed passes "12:00:00", the AM/PM setting automatically switches.

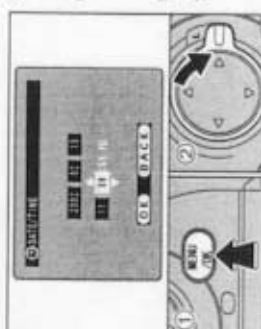

3. Press the "MENU/OK" button.
This switches the camera to Photography mode.
4. When you have finished the procedure, lock the 4-direction button to prevent accidental improper use.

To set the time precisely, press the "MENU/OK" button when the time is at zero seconds.
Once the AC power adapter has been connected or the batteries have been loaded for 2 days or more, the date and time settings will be retained for roughly 6 months even when the camera has no power (batteries removed and AC power adapter disconnected).

To correct the date/time

- 1 Press the "MENU/OK" button to display the SET-UP screen.
- 2 Use "▲" or "▶" to select "DATE/TIME" and then press "▶".

CHECKING THE BATTERY LEVEL

Switch the camera on and check the battery charge indicator.
1 There is ample charge in the batteries.
2 The batteries are low on charge and will run out shortly. You should replace the batteries.
3 The batteries are fully depleted. The display will immediately switch off and the camera will stop operating. Replace the batteries.

Loss of power while an image is being saved will prevent the image from being saved successfully. Take note of the battery level when you are taking shots where image saving will take some time (continuous shooting or when the quality is set to "HIGHT").

Lithium batteries (Top display panel)



AA-size batteries (Rear display panel)



1 Getting Ready

When you have difficulty obtaining lithium batteries

You can take pictures using only the four AA-size Ni-MH (nickel-metal hydride batteries), but the built-in flash cannot be used. When you are using only the four AA-size Ni-MH batteries, remove the used lithium batteries from the camera.

The time for which the camera can be used is shorter, and as far as possible this should only be used as an emergency measure. Note that the displays on the top and rear display panels both function as battery level indicators for the AA-size Ni-MH batteries.

- * When you are taking pictures in locations where you think you will have difficulty purchasing lithium batteries, it is a good idea to take along some spare lithium batteries or carry some fully charged Ni-MH batteries for emergencies.
- * The camera cannot be used just with alkaline batteries.

Batteries Uses and Symptoms When Batteries are Depleted

Batteries	Uses	Symptoms When Depleted
AA-size Alkaline batteries Lithium batteries CR123A	Image processing Power functions such as auto focus, spirit level, mirror and shutter operation, and charge the flash.	"E.P." appears on the top display panel The camera will not switch on.

Auto Power Off Function

If you leave the camera switched on without using it, this function automatically switches the camera off (P.98).
If the Auto Power Off function has shut down the camera, restore power to the camera by pressing the shutter button down halfway or pressing the LCD illuminator button. A small amount of battery charge is consumed even when Auto Power Off has shut down the camera.



- **Depth of field check button**
This button allows you to check the depth of field.
- **Power switch**
Switches the camera on and off.
- **Accessory shoe**
Mount an external flash here.
- **Flash pop-up button**
To use the built-in flash, press this button to pop up the flash.
- **Lens release button**
Hold down this button as you remove the lens.
- **Focus mode selector switch**
Selects AF-S (Single-AF servo), AF-C (Continuous-AF servo) or M (Manual) as the focus mode.

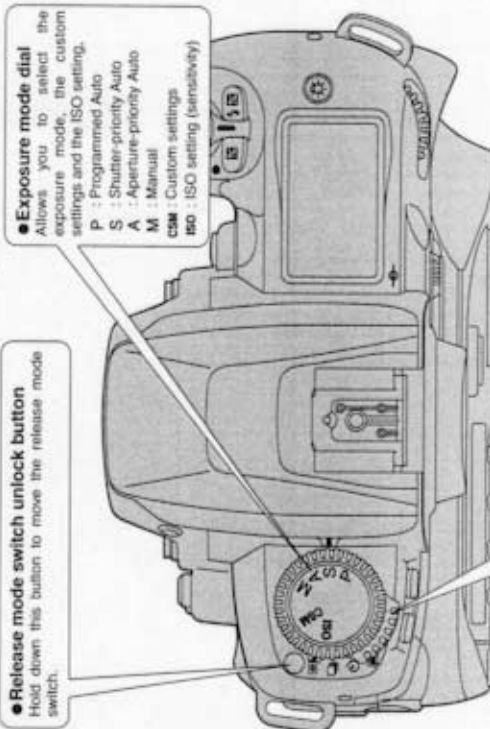

- **Release mode switch unlock button**
Hold down this button to move the release mode switch.
- **Exposure mode dial**
Allows you to select the exposure mode, the custom settings and the ISO setting.
P : Programmed Auto
S : Shutter-priority Auto
A : Aperture-priority Auto
M : Manual
CSM : Custom settings
ISO : ISO setting (semislowly)
- **Release mode switch**
Selects Single-frame, Continuous, Self Timer or Multi Exposure as the shutter release mode.

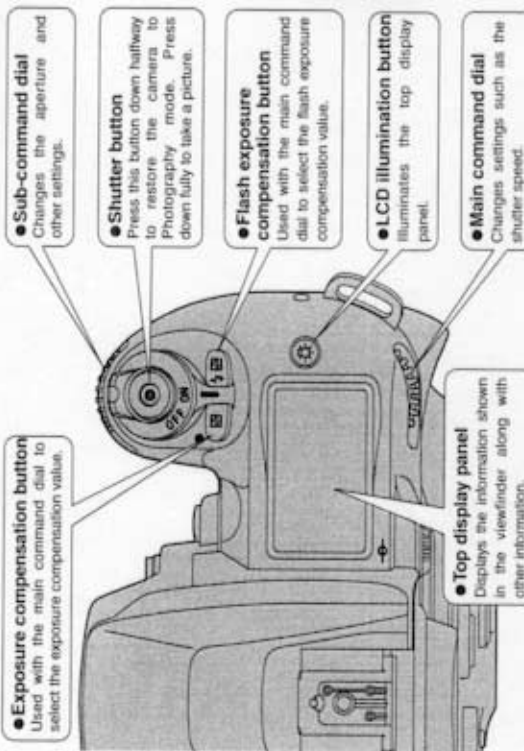

- **Exposure compensation button**
Used with the main command dial to select the exposure compensation value.
- **Sub-command dial**
Changes the aperture and other settings.
- **Shutter button**
Press this button down halfway to restore the camera to Photography mode. Press down fully to take a picture.
- **Flash exposure compensation button**
Used with the main command dial to select the flash exposure compensation value.
- **LCD illumination button**
Illuminates the top display panel.
- **Main command dial**
Changes settings such as the shutter speed.

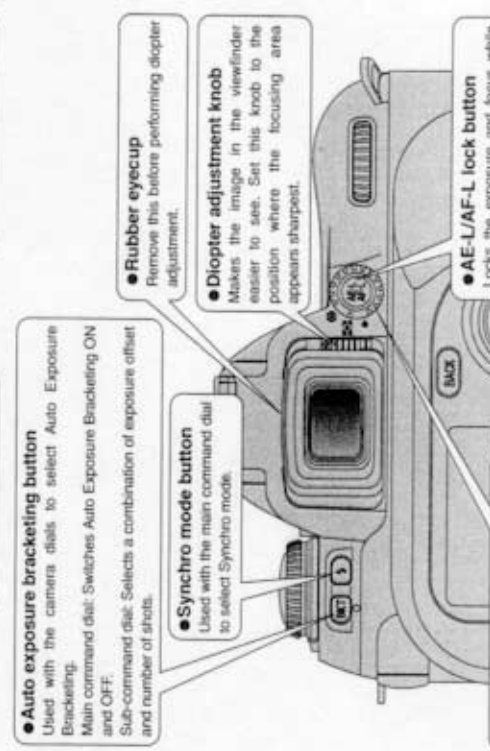

- **Top display panel**
Displays the information shown in the viewfinder along with other information.
- **Auto exposure bracketing button**
Used with the camera dials to select Auto Exposure Bracketing.
Main command dial: Switches Auto Exposure Bracketing ON and OFF.
Sub-command dial: Selects a combination of exposure offset and number of shots.
- **Rubber eyecup**
Remove this before performing diopter adjustment.
- **Diopter adjustment knob**
Makes the image in the viewfinder easier to see. Set this knob to the position where the focusing area appears sharpest.
- **Synchro mode button**
Used with the main command dial to select Synchro mode.
- **Metering system selector dial**
Selects Multi, Center-weighted or Spot as the metering system.
- **AE-L/AF-L lock button**
Locks the exposure and focus while pressed.

BASIC OPERATION GUIDE

- FUNC button**
Selects the information displayed on the rear display panel.
- BACK button**
Press this button to cancel an action in the menu screen.
- 4-direction button lock switch**
Release this switch to use the 4-direction button.
- MENU/OK button**
Press this button to confirm an action in the menu screen.
- 4-direction button**
Use this button to select menu options or the focus area.
- F1 to F4 buttons**
Use these buttons to select items in the rear display panel.
- PLAY button**
Switches playback display on and off.

Playback, Menu and SET-UP Operations

Playback: Frame advance (left/right arrows), Playback zoom (up/down arrows).
 MENU/OK: Confirms selection.
 Menu: Displays menu options.
 Shutter pressed halfway: Triggers menu navigation.
 LCD monitor OFF: Turns off the LCD monitor.
 MENU/OK: Confirms menu selection.
 SET-UP: Displays the setup menu.
 MENU/OK: Confirms setup selection.
 Photography: Returns to the main camera view.

(1) Menu option selection: (left/right arrows)
 (2) Setting selection: (up/down arrows)
 (3) Confirmation/MENU/OK
 Cancel: BACK

Command dials

The FinePix S2 Pro's Main- and Sub-Command dials are used alone or in combination with other buttons to select/set various functions or modes.

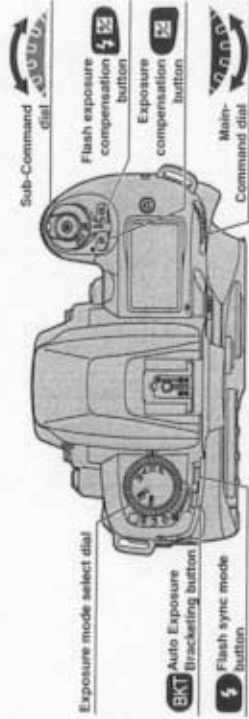

Setting	Exposure mode setting	Procedure
Program shift	"P"	Main
Shutter speed	"S, M"	Main Shutter speed/Flash
Aperture setting	"A, M"	Sub Aperture
Exposure compensation amount	"P, S, A, M"	Main + Exposure compensation
Auto Exposure Bracketing ON/OFF	"P, S, A, M"	Main + BKT
Number of shots and exposure offset for Auto Exposure Bracketing	"P, S, A, M"	Sub + BKT
Synchro mode setting	"P, S, A, M"	Main + Flash
Flash exposure compensation amount	"P, S, A, M"	Main + Flash exposure compensation
Sensitivity setting	"ISO"	Main + ISO
Custom setting option selection	"CSM"	Main + CSM
Custom setting option modification	"CSM"	Sub - CSM

TAKING PICTURES



1 Set the focus mode selector to "S" (Single-AF Servo).

Make sure to turn the focus mode selector until it clicks into position.

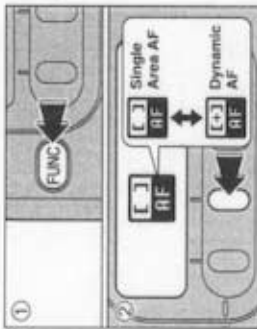

2 Press the "FUNC" button to display the AF setting on the rear display panel.

Press the "F2" button to select "single" area.

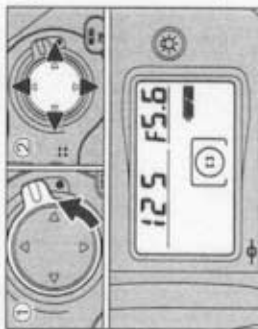

3 Unlock the 4-direction button.

Press "←", "→", "▲", or "▼" to position the focusing area in the center.

The selected focus area indicator appears on the top display panel, in the viewfinder display and on the viewfinder screen (P.39).



4 Lock the 4-direction button to prevent accidental improper use.



5 Hold down the release mode switch unlock button and set the release mode switch to "S" (Single-frame).

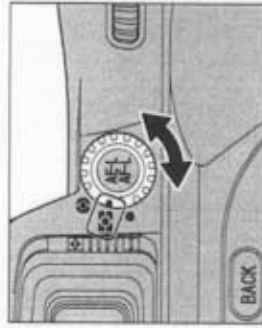

6 Set the metering system selector to "M" (Matrix Metering).

Main Metering indication "M" appears in the viewfinder.



7 Set the exposure mode select dial to "P" (Auto-Multi Program).



8 Brace your elbows against your body and hold the camera with both hands.

Take care not to obscure the lens with your fingers or the shoulder strap.



9 Position the central focus area over the subject.

If the subject is not inside the AF frame, move the focus area or take the picture using AF lock (P.33).

TAKING PICTURES

Press the shutter button halfway to focus the shot. The **●** focus indicator appears in the viewfinder display.



● If the focus indicator is flashing, the camera cannot focus and the shutter will not release.

Without releasing the shutter button, press it down all the way (fully pressed) to take the shot.



NUMBER OF AVAILABLE SHOTS

The number of available shots is displayed on the rear display panel.



● See P.00 for information on changing the number of recorded shots/Quality (compare an ratio) setting.
● This factory default settings set at shipment are: 3024 (Number of recorded pixels) and N (Quality: normal).

Standard Number of Shots for the Media

Because the amount of data needed to record an image varies slightly depending on the type of subject, the number of available shots may not decrease after an image is recorded, or may decrease by 2 in some cases. Also, the difference between the standard number of shots and the actual number of available shots increases for media with a higher capacity.

Number of recorded pixels	1500		3024 × 2016		4256 × 2840		5625 × 3600		7680 × 4608		1440 × 1080	
	HIGH (5FF:RGB)	CD-ROM	HIGH (5FF:RGB)	FINE	NORMAL	FINE	NORMAL	HIGH (10FF:RGB)	FINE	NORMAL	HIGH (10FF:RGB)	FINE
Quality Mode												
Image File Size	Approx. 25.9MB	12.4MB	Approx. 2.3MB	1.5MB	Approx. 1.3MB	1.0MB	Approx. 1.0MB	0.8MB	0.6MB	0.5MB	0.4MB	0.3MB
MG-RS (10MB)	0	1	3	6	0	6	13	1	10	23	3	22
MG-S2S (20MB)	0	2	6	13	1	12	27	3	22	47	7	45
MG-HS (40MB)	1	4	13	28	3	26	55	6	45	94	15	92
MG-LSS (120MB)	3	9	26	56	7	52	112	12	90	189	30	185
MK-1 (240MB)	9	26	73	156	19	145	307	33	246	525	64	507
MK-1 (1000)	29	80	220	468	58	437	912	100	746	1564	254	1492

* Number of available shots for formatted media.

USING AF LOCK

1 If you take a shot with this type of composition using Single-area AF with the focus area in the center, the subjects (the two people in this case) are outside the focus area and will not be in focus.



2 Move the camera slightly so that one of the subjects is in the AF frame.



3 Keep the shutter button pressed down halfway (AF lock) and check that the **●** focus indicator is lit in the viewfinder display.



● If you are using the "AF-C" focus mode, hold the shutter button down halfway and press the "AE-L/AF-L" button (→P.05).

4 Continue to hold the shutter button down halfway (AF lock). Move the camera back to the original image and then fully press down on the shutter button.



● You can reapply the AF lock as many times as you like before releasing the shutter.
● The AF lock operates in all photography modes and can be used to ensure excellent results.

When AF (Auto Focus) does not focus the shot

- Position the focus area over another subject at roughly the same distance and press the shutter button down halfway. Then recompose the shot and take the picture.
- You can also set the focus and take the shot by selecting "M" (manual) as the focus mode.

PLAYING BACK IMAGES

Press the "PLAY" button to play back your images.

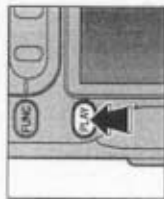

Frame advance/rewind

Press "▲" or "▼" to move backwards and forwards through the images.

Hold the button down for about 1 second to move quickly through the images.

Images appear slightly coarser during fast forwarding.

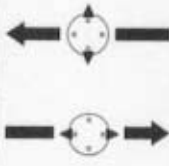

Use "▲" or "▼" to zoom in or out.



Lock the 4-direction button to prevent accidental improper use.

When you have finished viewing the images...

(PLAY) Switches between zooming and repositioning.

Panning



Press "▲", "▼", "▲", or "▼" to view a different area.

Press "BACK" to return to frame advance mode.

To take a shot when you are viewing images, press the "SHUTTER" button or press the shutter button down halfway.

DIOPTRIC ADJUSTMENT/LCD ILLUMINATOR

DIOPTRIC ADJUSTMENT

The finder dioptre enables near- or far-sighted photographers to adjust the eyepiece dioptre to suit their vision.



Remove the rubber eyecup.

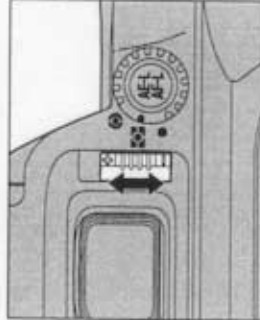

While looking through the viewfinder, adjust the position of the diopter adjustment knob until the focusing frame or the image in the viewfinder appears sharpest. Then reattach the rubber eyecup.

The diopter setting can be adjusted from -1.8 m⁻¹ (shortsighted) to 0.8 m⁻¹ (farsighted). Nikon also provides 9 types of diopter adjustment lens ranging from -5 m⁻¹ to 3 m⁻¹.

Since the diopter adjustment lever is located next to the viewfinder, be careful not to poke yourself in the eye with your finger or fingernail while sliding the lever.

LCD ILLUMINATOR

Displays in the top display panel can be confirmed in the dark with the LCD illuminator.

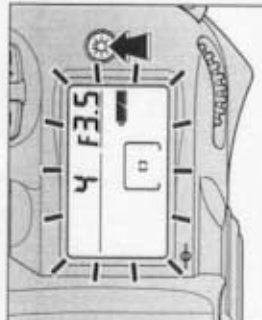

When you press the "LCD" illuminator button, the top and rear display panels light up.

Display panel illumination switches off in the following situations:

- When you press the "LCD" illumination button again
- When you release the shutter
- When the Auto Power Off function switches the camera off

Pressing the shutter button down halfway temporarily switches display panel illumination off.

CMS 14: The illuminator can be set to come on when any button is pressed (→P.98).

DEPTH OF FIELD CHECK BUTTON/CCD PLANE INDICATOR

DEPTH OF FIELD CHECK BUTTON

Depress the depth-of-field check button to confirm the depth of field through the viewfinder.

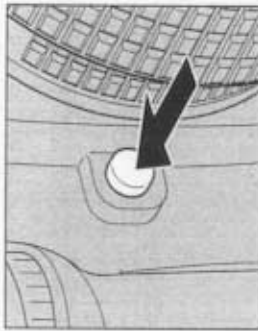

Pressing the depth-of-field check button stops the lens down to the aperture controlled in "P" Auto-Multi Program or "S" Shutter-Priority Auto exposure mode, and down to the aperture selected in "A" Aperture-Priority Auto or "M" Manual exposure mode. By looking through the viewfinder, the approximate depth of field with the given aperture can be confirmed.

When you press the depth of field check button, the shutter speed display and LCD illumination both turn off.

CCD PANEL INDICATOR

The CCD plane indicator shows the position of the CCD plane inside the camera body.

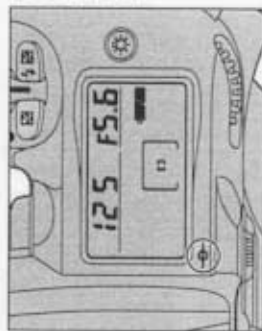

The CCD plane indicator shows the standard line of the shooting distance and indicates the position of the CCD plane inside the camera body. Use this indicator when actually measuring camera-to-subject distance, e.g., in close-up photography. The exact distance from the lens mounting flange to the CCD plane is 46.5 mm.

3 Advanced Photography FOCUS SETTINGS

Pages 38 to 43 provide explanations of how to use and set the camera's focusing functions, along with various related topics. The diagram below is a page map to this section. Refer to the pages indicated for details.

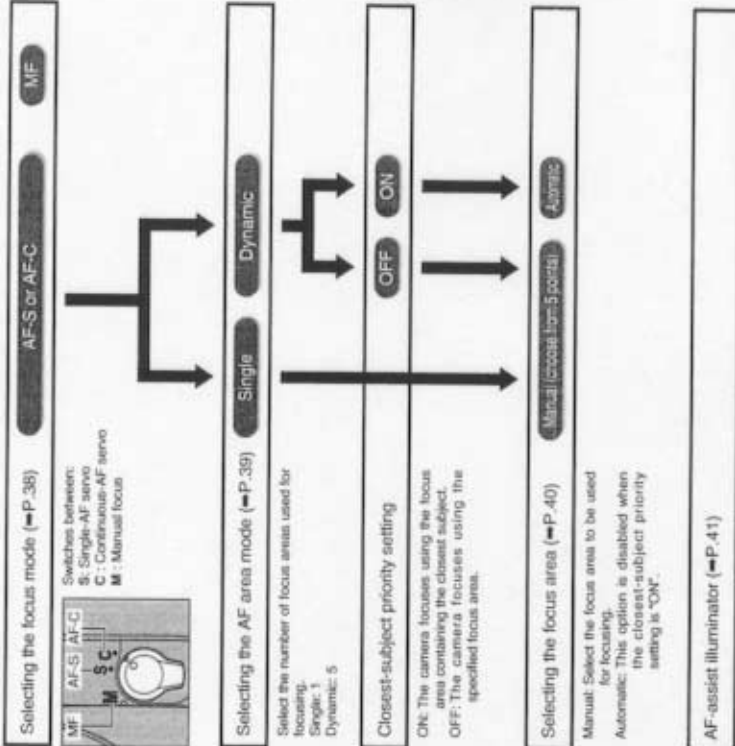

Focus-related custom settings

CSM 3: Illumination for focus area	Sets the automatic illumination setting for the focus area in the viewfinder.	P.97
CSM 4: Focus area selection	Sets the focus area selection method	P.97
CSM 7: Closest-subject priority dynamic AF at S-AF mode	Closest-subject priority dynamic AF settings	P.97
CSM 8: Closest-subject priority dynamic AF at C-AF mode	Sets the closest-subject priority dynamic AF settings	P.97
CSM 9: AE/AF lock button	Selects AE/AF concurrent locking, independent locking, or maintained locking	P.97
CSM 15: AF-assist illuminator	Switches auxiliary AF light ON/OFF	P.98

FOCUS SETTINGS

SELECTING THE FOCUS MODE

Use the focus mode selector switch to select the focus mode.

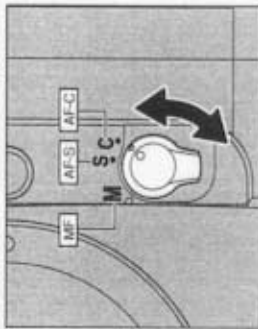

Focus modes

Features	AF-S (S: Single AF servo)	AF-C (C: Continuous AF servo)	MF (M: Manual focus)
AF starts	Focus priority mode. The shutter will only release if the focus indicator is displayed. (Excludes predictive motion focusing)	Release priority mode. The shutter will release even if the focus indicator is not displayed.	Allows you to release the shutter at any time.
Focus lock	When the shutter button is pressed down halfway (default).	When the shutter button is pressed down halfway (default).	AF is not used.
Predictive motion focusing (focus tracking function for moving subjects)	When the shutter button is held down halfway and the focus indicator is displayed, the focus is locked.	Even when the shutter button is held down halfway and the focus indicator is displayed, the focus is not locked and focusing continues. Press the AE-L/AF-L button to lock the focus.	The focus is not locked.
	Only works for moving subjects from the time AF operation starts. While this function is operating, the camera decides when the subject is in focus and releases the shutter.	Also works for subjects that start moving during shooting.	Does not operate.

CSM 9: AF operation can be modified so that it does not begin when the shutter button is pressed down halfway, but when the "AE-L/AF-L" button is pressed (P.97).

You can change the focusing method used for automatic focusing (when the focus mode switch is set to "S" or "C").

SELECTING THE AF AREA MODE

Single-area AF	<ul style="list-style-type: none"> Focuses using the selected focus area. Useful for situations where you want to focus accurately on a more or less stationary subject.
Dynamic AF	<ul style="list-style-type: none"> If the subject is outside the specified focus area, another focus area is used for focusing. Useful for shots where it is difficult to accurately keep the subject in a given focus area, such as when you are tracking a moving subject (particularly one that moves in unpredictable ways).
Closest-subject Priority AF	<ul style="list-style-type: none"> Focuses using the focus area containing the subject closest to the camera.

If spot metering is used in Closest-subject Priority AF mode, metering is always performed for the focus area in the center of the shot.

When you are using a telephoto lens or the subject is dark, the closest focus area may not be selected.

CSM 7/8: The focus mode determines whether Closest-subject Priority AF is ON or OFF. The default settings are "ON" in "S" (Single-AF servo) mode and "OFF" in "C" (Continuous-AF servo) mode. You can change these settings using the custom settings (P.97).

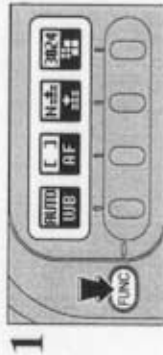

1

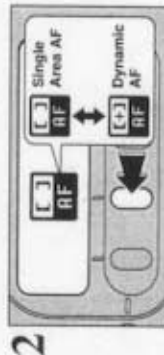

2

The displays shown in the viewfinder and on the top display panel are shown below.

Focus area	Single-area AF	Dynamic AF (Closest-subject Priority AF OFF)	Dynamic AF (Closest-subject Priority AF ON)
Focus area			
Top display panel/viewfinder display			

Then specify the focus area.

End of settings.

FOCUS SETTINGS

1 Selecting the focus area

Unlock the 4-direction button.



Press **←**, **→**, **▲**, or **▼** to select the focus area. Once you have specified the focus area, lock the 4-direction button to prevent accidental improper use.

- The specified focus area is automatically illuminated in red according to the brightness of the subject.

CSM 3: The specified focus area is automatically illuminated, but you can change the settings so that the illumination is disabled or is no longer dependent on the subject brightness (→P.97).

CSM 4: Allows you to select the opposite focus area without pressing a different part of the 4-direction button (→P.97).

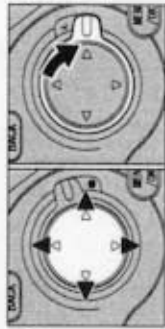

AF-ASSIST ILLUMINATOR

When the subject is dark and the shutter release button is pressed lightly, the camera's AF-Assist Illuminator automatically turns on and enables autofocus operation in a dark environment.

AF-Assist Illuminator automatically turns on in the following situations:

Focus mode is Single Servo AF, AF Nikkor lens is used, subject is dark and centre focus area is selected or Dynamic AF Mode with Closest Subject Priority is activated.

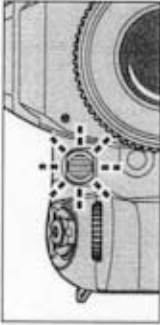

Focal length of the usable AF Nikkor lens is 24-200 mm and the distance range of the AF-Assist Illuminator is approx. 0.5-3 m (1.6-9.8 ft).



CSM 15: AF-Assist Illuminator can be cancelled (→P.98).

When the AF-Assist Illuminator is used continuously, illumination is limited temporarily to protect the firing tube. The illumination resumes after a few moments. Also, when the AF-Assist Illuminator is used repeatedly in a short period of time, be careful not to touch the AF-Assist Illuminator lamp because it may have become hot.

◆ Nikon flash units and active auxiliary flash ◆

If you use an SB-26/28DX, SB-27, SB-26, SB-25 or SB-24 Nikon flash to take pictures when the conditions for active assist illuminator are met, the active assist illuminator on the Nikon flash automatically fires. With other Nikon flash models, the AF-assist illuminator on the camera automatically lights.

◆ Lenses For Which Vignetting Occurs ◆

Autofocus using the camera's AF-Assist Illuminator cannot be performed due to vignetting with following lenses at shooting distance within 1m:

- AF Micro 200 mm f/4 IF-ED
- AF 24-85 mm f/2.8-4
- AF-S 17-35 mm f/2.8 IF-ED
- AF 24-120 mm f/3.5-5.6 IF
- AF 18-35 mm f/3.5-4.5 ED
- AF-S 28-70 mm f/2.8 IF-ED
- AF 20-35 mm f/2.8 IF
- AF Micro 70-180 mm f/4.5-5.6 ED
- Autofocus using the camera's AF-Assist Illuminator cannot be performed due to vignetting with AF-S 80-200 mm f/2.8 IF-ED, AF 80-200 mm f/2.8 ED and AF VR 80-400 mm f/4.5-5.6 ED.

SITUATIONS WHERE AUTOFOCUS MAY NOT WORK AS EXPECTED

Autofocus may not work as expected in the following situations. In such situations, focus manually using the clear matte field or focus on a different subject located at the same distance, use AF lock (P. 33) then recompose.



Low-contrast scenes

For example, where the subject is wearing clothing the same colour as a wall or other background.



Scenes with subjects within the focus brackets located at different distances from the camera. For example, when shooting an animal in a cage or a person in a forest.

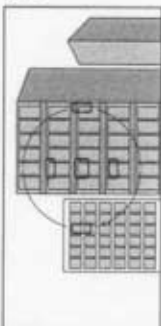

Patterned subject or scene. For example, building windows.



Scenes with pronounced differences in brightness within the focus brackets. For example, when the sun is in the background and the main subject is in shadow.

MANUAL FOCUS

Use Manual focus in situations where autofocus may not work as expected (P. 42) or a lens other than an AF Nikkor lens (P. 19) is attached.

Focus can be set manually when the focus mode selector is set to M.

Focus the camera by turning the focusing ring on the lens until the image can be seen clearly in the matt surface of the viewfinder screen.

- When using a lens with the A-M select function, set the switching to "M" to focus manually. If "M/A" (autofocus with manual priority) is available with your lens, Manual focus is possible either with the switching set to "M" or "M/A". See the instruction manual of your lens for details.



Focus Aid

This allows you to check the focus of your shot using the focus indicator in the viewfinder. You can use Focus Aid when the lens mounted has an f-stop setting brighter than f/5.6.

- Position the selected focus area over the object on which you want to focus.
- Turn the focusing ring on the lens.



2



Press the shutter button down halfway. When the shot is in focus, the focus indicator lights.

AF indicator

To make focusing easier on this camera, the range in which the focus indicator lights is set to a fixed size. As a result, the camera does not react to slight movements of the focusing ring, thereby avoiding flickering in the focus indicator. However, this means that the focusing position at the wide-angle setting is very slightly different from the focusing position at the telephoto setting, so that the shot may not be optimally focused even when the focus indicator is lit. In this situation, you can focus precisely by positioning the focusing ring in the middle of the range in which the focus indicator lights.