

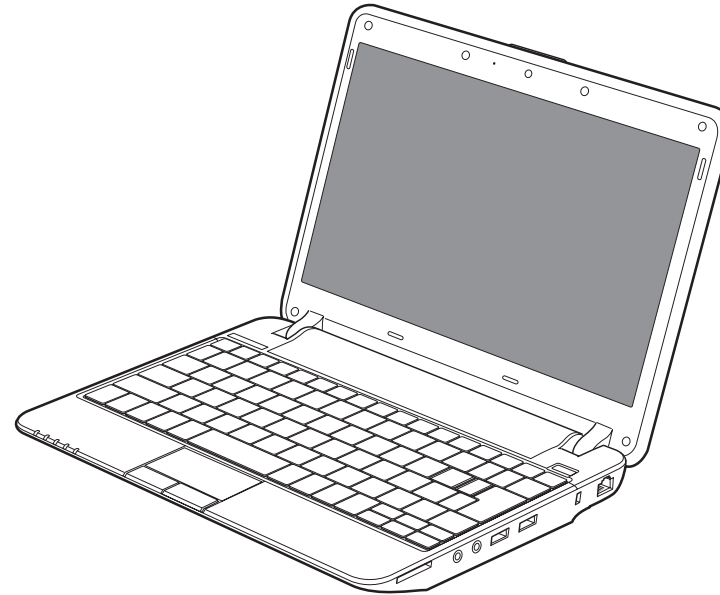

User's Guide

Learn how to use
your Fujitsu LifeBook
P3010 notebook



FUJITSU

THE POSSIBILITIES ARE INFINITE



Copyright and Trademark Information



Fujitsu America, Inc. has made every effort to ensure the accuracy and completeness of this document; however, as ongoing development efforts are continually improving the capabilities of our products, we cannot guarantee the accuracy of the contents of this document. We disclaim liability for errors, omissions, or future changes.

Fujitsu and the Fujitsu logo are registered trademarks of Fujitsu Limited.

Intel and Intel Atom are trademarks or registered trademarks of Intel Corporation or its subsidiaries in the United States and other countries.

Microsoft and Windows are either registered trademarks or trademarks of Microsoft Corporation in the United States and/or other countries.

Bluetooth is a trademark of Bluetooth SIG, Inc., USA.

ENERGY STAR and the ENERGY STAR certification mark are registered trademarks of the U. S. Government.

Adobe, Acrobat, and Acrobat Reader are either a registered trademarks or trademarks of Adobe Systems Incorporated in the United States and/or other countries.

Roxio is a trademark of Roxio, a division of Sonic Solutions.

PowerDVD and YouCam are trademarks of CyberLink Corp.

Athlon is a trademark of Advanced Micro Devices, Inc.

Norton and Norton Internet Security are trademarks or registered trademarks of Symantec Corporation in the United States and other countries.

All other trademarks mentioned herein are the property of their respective owners.

© Copyright 2009 Fujitsu America, Inc. All rights reserved.

No part of this publication may be copied, reproduced, or translated, without prior written consent of Fujitsu. No part of this publication may be stored or transmitted in any electronic form without the written consent of Fujitsu.

B6FJ-DRAFT-



DECLARATION OF CONFORMITY

according to FCC Part 15

Responsible Party Name: Fujitsu America, Inc.
Address: 1250 E. Arques Avenue
Sunnyvale, CA 94085
Telephone: (408) 746-6000
Declares that product: Base Model Configuration:
Fujitsu P3010 notebook

Complies with Part 15 of the FCC Rules.

This device complies with Part 15 of the FCC rules. Operations are subject to the following two conditions:
(1) This device may not cause harmful interference, (2) This device must accept any interference received,
including interference that may cause undesired operation.



WARNING

HANDLING THE CORD ON THIS PRODUCT WILL EXPOSE YOU TO LEAD, A CHEMICAL KNOWN TO THE STATE OF CALIFORNIA TO CAUSE BIRTH DEFECTS OR OTHER REPRODUCTIVE HARM.

WASH HANDS AFTER HANDLING.

IMPORTANT SAFETY INSTRUCTIONS

This unit requires an AC adapter to operate. Use only UL Listed I.T.E. Class II Adapters with an output rating of 19 VDC, with a minimum current of 3.16 A (60 W).

AC adapter output polarity:



When using your notebook equipment, basic safety precautions should always be followed to reduce the risk of fire, electric shock and injury to persons, including the following:

- **CAUTION - HOT SURFACE:** The bottom of this notebook computer can become hot when used for long periods of time. When using this notebook, take caution to limit long term or continuous use while resting it on exposed skin, such as the lap.
- Do not use this product near water for example, near a bathtub, washbowl, kitchen sink or laundry tub, in a wet basement or near a swimming pool.
- Avoid using a modem during an electrical storm. There may be a remote risk of electric shock from lightning.
- Do not use a modem to report a gas leak in the vicinity of the leak.
- Use only the power cord and batteries indicated in this manual. Do not dispose of batteries in a fire. They may explode. Check with local codes for possible special disposal instructions.
- To reduce the risk of fire, use only No. 26 AWG or larger UL Listed or CSA Certified Telecommunication Line Cord.
- For TV tuner use: To protect from overvoltages and transients on the Cable Distribution System, make sure that the outer shield of the coaxial cable is connected to earth (grounded) at the building premise as close to the point of cable entrance as practicable, as required per NEC Article 820.93, ANSI/NFPA 70: 2005. If you have questions about your CATV installation, contact your service provider.

SAVE THESE INSTRUCTIONS

For Authorized Repair Technicians Only



DANGER OF EXPLOSION IF LITHIUM (CLOCK) BATTERY IS INCORRECTLY REPLACED. REPLACE ONLY WITH THE SAME OR EQUIVALENT TYPE RECOMMENDED BY THE MANUFACTURER. DISPOSE OF USED BATTERIES ACCORDING TO THE MANUFACTURER'S INSTRUCTION.



FOR CONTINUED PROTECTION AGAINST RISK OF FIRE, REPLACE ONLY WITH THE SAME TYPE AND RATING FUSE.

Recycling your battery

Over time, the batteries that run your mobile computer will begin to hold a charge for a shorter amount of time; this is a natural occurrence for all batteries. When this occurs, you may want to replace the battery with a fresh one*. If you replace it, it is important that you dispose of the old battery properly because batteries contain materials that could cause environmental damage if disposed of improperly.



Fujitsu is very concerned with environmental protection, and has enlisted the services of the Rechargeable Battery Recycling Corporation (RBRC)**, a non-profit public service organization dedicated to protecting our environment by recycling old batteries at no cost to you.

RBRC has drop-off points at tens of thousands of locations throughout the United States and Canada. To find the location nearest you, go to www.RBRC.org or call 1-800-822-8837.

If there are no convenient RBRC locations near you, you can also go to the EIA Consumer Education Initiative website (<http://EIAE.org/>) and search for a convenient disposal location.

Remember – protecting the environment is a cooperative effort, and you should make every effort to protect it for current and future generations.

* To order a new battery for your Fujitsu mobile computer, go to the Fujitsu shopping site at www.shopfujitsu.com in the US or www.fujitsu.ca/products/notebooks in Canada.

** RBRC is an independent third party to which Fujitsu provides funding for battery recycling; RBRC is in no way affiliated with Fujitsu.



Contents

Preface

About This Guide	14
Conventions Used in the Guide	14
Fujitsu Contact Information	15

Chapter 1 Getting to Know Your Notebook

Overview	17
Locating the Controls and Connectors	18
Front and Display Components	21
Left-Side Panel Components	22
Right-Side Panel Components	24
Bottom Components	26
Status Indicator Panel	28
Power Indicator	29
Hard Drive Access Indicator	30
CapsLock Indicator	30
NumLk Indicator	30

Display Panel	31
Opening the Display Panel	31
Adjusting Display Panel Brightness	32
Keyboard	33
Using the Keyboard	33
Touchpad Pointing Device	36
Clicking	37
Double-Clicking	38
Dragging	39
Touchpad Control Adjustment	39
Volume Control	40
Controlling the Volume	40
Chapter 2 Getting Started with Your Notebook	
Power Sources	42
Connecting the Power Adapters	42
Starting Your P3010 LifeBook	43
Power On	43
Boot Sequence	44
BIOS Setup Utility	44
Booting the System	45
Starting Windows the First Time	46
Installing ClickMe!	47
Fujitsu Driver Update Utility	47

Power Management	48
Power/Suspend/Resume Button	48
Standby Mode	49
Hibernation (Save-to-Disk) Feature	50
Windows Power Management	50
Restarting the System	50
Powering Off	51
ENERGY STAR® Compliance	52

Chapter 3 User-Installable Features

Lithium ion Battery	53
Recharging the Batteries	54
Replacing the Battery	55
Memory Upgrade Module	58
Removing Memory Modules	58
Installing a Memory Upgrade Module	60
Checking the Memory Capacity	61
Memory Stick/Secure Digital Cards	62
Inserting MS/SD Cards	63
Removing an MS/SD Card	63
Device Ports	64
Internal LAN (RJ-45) jack	64
Headphone Jack	64
Microphone Jack	65
Universal Serial Bus Ports	65
External Video Port	65

Chapter 4 Troubleshooting Your Notebook

Troubleshooting	67
Identifying the Problem	67
Specific Problems	69
Troubleshooting Table	69
Power On Self Test Messages	77
Restoring Your System Image and Software	80
Drivers and Applications Restore Disc	80
Recovery and Utility Disc	81
Automatically Downloading Driver Updates	82

Chapter 5 Care and Maintenance

Caring for your P3010 LifeBook	83
Cleaning your notebook	85
Cleaning the dust filter	86
Storing your notebook	87
Traveling with your notebook	88
Batteries	89
Media Care	90

Chapter 6 System Specifications

Specifications	91
Configuration Label	91
Microprocessor	92
Chipset	92
Memory	92
Video	92
Audio	93
Mass Storage Device Options	93

Features	93
Device Ports	94
Keyboard	94
Power	94
Dimensions and Weight	95
Environmental Requirements	95
Popular Accessories	95
Included Software	96
Learning About Your Software	96

Glossary/Regulatory

Glossary	98
---------------------------	-----------

Regulatory Information	112
---	------------

Appendix A: WLAN User's Guide

Before Using the Optional Wireless LAN	117
---	------------

Wireless LAN Device Covered by this Document	117
Characteristics of the WLAN Device	117
Wireless LAN Modes Using this Device	118
Deactivating the WLAN Device	120
Disconnection Using the Icon in the Taskbar	120
Activating the WLAN Device	121

Configuring the Wireless LAN	122
---	------------

Configuring the WLAN using Windows XP	122
Connection to the network	122

Troubleshooting the WLAN	123
---	------------

Troubleshooting	123
---------------------------	-----

WLAN Specifications 125
 Specifications 125

Using the Bluetooth Device. 127
 What is Bluetooth 127
 Where to Find Information About Bluetooth 127

Index. 129



Preface

About This Guide

The P3010 LifeBook from Fujitsu is a small yet powerful computer, perfect for networking. It is powered by an AMD Athlon™ Neo MV-40 processor and integrated AMD RS780MN chipset. The notebook has a built-in 11.6” wide SVGA color display with LED backlight.

This manual explains how to operate your P3010 notebook’s hardware and built-in system software. Your P3010 notebook comes with Windows® 7 Home Premium Edition pre-installed.

Conventions Used in the Guide

Keyboard and on-screen keys appear in brackets. Example: [Fn], [F1], [ESC], [ENTER] and [CTRL].

Pages with additional information about a specific topic are cross-referenced within the text.

For example: (“See [Installation Procedure on page 43](#)”.) Note that all cross-references are linked to the referenced items, so by clicking the link, you will automatically go to the referenced item or page.

On-screen menu items appear in bold. Example: “Click **Object Properties** and select your choice”.



THE INFORMATION ICON HIGHLIGHTS INFORMATION THAT WILL ENHANCE YOUR UNDERSTANDING OF THE SUBJECT MATERIAL.



THE CAUTION ICON HIGHLIGHTS INFORMATION THAT IS IMPORTANT TO THE SAFE OPERATION OF YOUR COMPUTER, OR TO THE INTEGRITY OF YOUR FILES. PLEASE READ ALL CAUTION INFORMATION CAREFULLY.



THE WARNING ICON HIGHLIGHTS INFORMATION THAT CAN BE HAZARDOUS TO EITHER YOU, YOUR NOTEBOOK, OR YOUR FILES. PLEASE READ ALL WARNING INFORMATION CAREFULLY.

Fujitsu Contact Information

Service and Support

You can contact Fujitsu Service and Support in the following ways:

- Toll free: 1-800-8Fujitsu (1-800-838-5487)
- Website: <http://www.computers.us.fujitsu.com/support>

Before you place the call, you should have the following information ready so that the customer support representative can provide you with the fastest possible solution:

- Product name
- Product configuration number
- Product serial number
- Purchase date
- Conditions under which the problem occurred
- Any error messages that have occurred
- Type of device connected, if any

Fujitsu Shopping Online

You can go directly to the online by going to the website at: www.shopfujitsu.com.



YOU MUST HAVE AN ACTIVE INTERNET CONNECTION TO USE THE ONLINE URL LINKS.

Limited Warranty

Your P3010 notebook is backed by a Fujitsu International Limited Warranty. Check the service kit that came with your notebook for the Limited Warranty period and terms and conditions.

Chapter 1

Getting to Know Your Notebook

Overview

This section describes the components of your Fujitsu P3010 LifeBook notebook. We strongly recommend that you read it before using your notebook – even if you are already familiar with notebook computers.

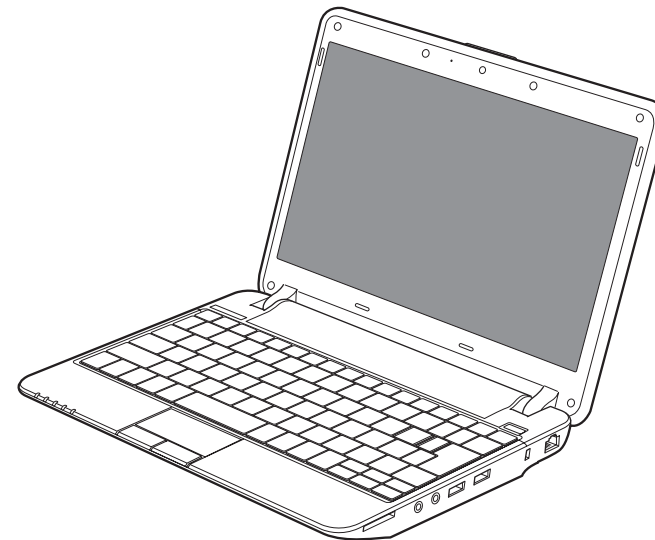













Figure 1. Fujitsu P3010 LifeBook

Locating the Controls and Connectors

Connectors and peripheral interfaces on the P3010 notebook allow you to connect a variety of devices. Specific locations are illustrated in Figures 2 through 5. The table below provides a short description of each icon on the P3010 notebook. Each of the icons is either molded into or printed on the notebook chassis.

Connection	Notebook Icon	Purpose
DC in connector		Connect an external power source such as the AC adapter or auto/airline adapter.
Secure Digital/ Memory Stick (SD/MS) Slot		The Secure Digital/Memory Stick (SD/MS) card slot allows you to install a flash memory card for data storage. Flash memory cards allow you to transfer data to and from a variety of different digital devices.
USB Ports		Connect Universal Serial Bus 2.0 or 1.1 compliant devices to the notebook.
Microphone Jack		Connect an external microphone. The internal microphone is disabled when you plug in an external microphone. The same icon is used for the internal microphone.
Headphone Jack		Connect stereo headphones or powered external speakers. The internal speaker is disabled when you plug in external headphones or powered speakers.
Security lock slot		The security slot allows you to secure the notebook using compatible locking devices.

Connection	Notebook Icon	Purpose
Suspend/ Resume button		The Suspend/Resume button allows you to suspend notebook activity without powering off, resume your notebook from suspend mode, and power on the system when it has been shut down from Windows.
Local Area Network (LAN)		The LAN (RJ-45) jack is used to connect the internal 10/100 Base-T/Tx Ethernet to a Local Area Network (LAN) in your office or home, or broadband devices such as a cable modem, DSL, or satellite Internet.
Battery Release Latch		The battery release latch allows you to remove the battery from your system for storage or replacement.
Wireless LAN On-Off Switch		The wireless LAN switch allows you to turn power to the optional wireless LAN device on and off.
External Video port		The external video port allows you to connect an external monitor or LCD projector to your computer.

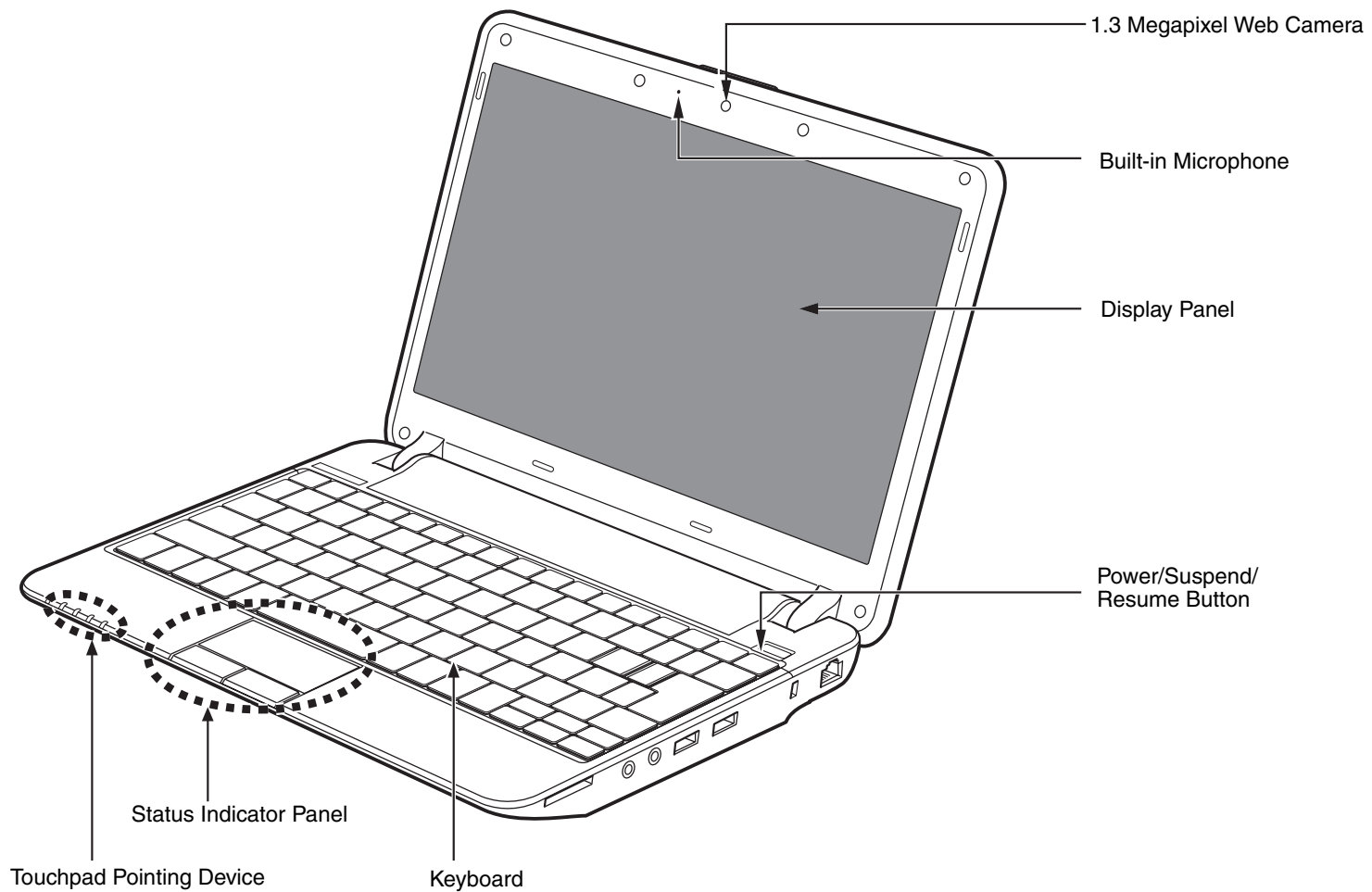

Figure 2. P3010 LifeBook with display open

Front and Display Components

The following is a brief description of your notebook's front and display features.

Web Camera

The 1.3 megapixel web camera allows you to take pictures of yourself to send over the internet. For information on using the camera, see the documentation associated with the ArcSoft WebCam Companion application.

Built-in Microphone

The built-in microphone allows you to input mono audio.

Display Panel

The display panel is a color LCD panel with back lighting for the display of text and graphics and touch screen functionality.

Power/Suspend/Resume Button

The Power/Suspend/Resume button allows you to suspend system activity without powering off, resume your system from standby mode, and power on your system when it has been shut down from the Windows operating system. See "Power On" on page 43.

Keyboard

A full-function keyboard with dedicated Windows keys. See "Keyboard" on page 33.

Status Indicator Panel

There are two Status Indicator Panels that display symbols corresponding to specific components of your P3010 notebook. See "Status Indicator Panel" on page 28.

Touchpad Pointing Device

The Touchpad pointing device is a mouse-like cursor control with a right button, a left button, and a cursor control pad. See "Touchpad Pointing Device" on page 36.

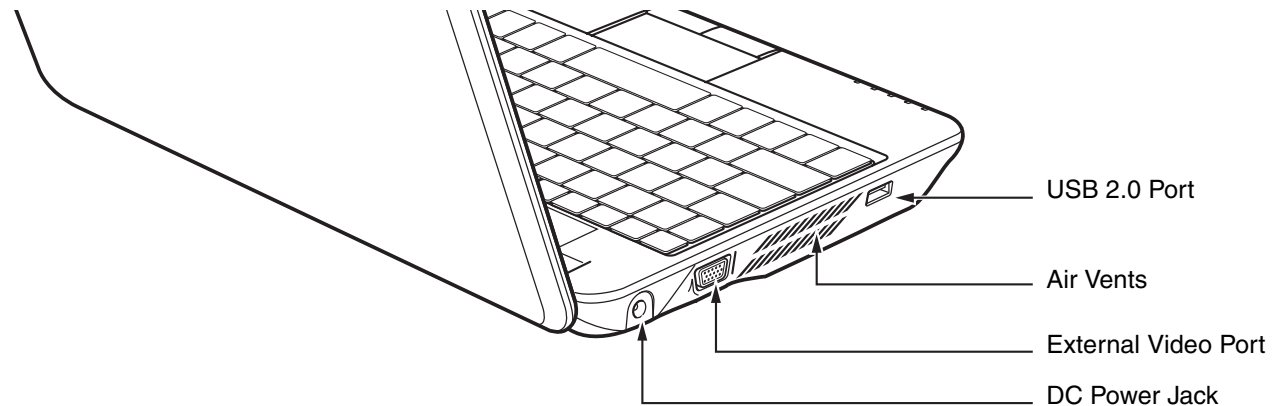

Figure 3. P3010 Lifebook left-side panel

Left-Side Panel Components

The following is a brief description of your notebook's left-side components.

USB 2.0 Ports

The three USB 2.0 ports (one on the left side, two on the right side) allow you to connect Universal Serial Bus devices. USB 2.0 transfers data at up to 480 Mbps and is backward-compatible with USB 1.1 devices, which transfer data at up to 12 Mbps. See "Universal Serial Bus Ports" on page 65.

Air Vents

The air vents allow proper air circulation to ensure that the system does not overheat.



TO PROTECT YOUR NOTEBOOK FROM DAMAGE AND TO OPTIMIZE SYSTEM PERFORMANCE, BE SURE TO **KEEP ALL AIR ALL VENTS UNOBSTRUCTED, CLEAN, AND CLEAR OF DEBRIS.** THIS MAY REQUIRE PERIODIC CLEANING, DEPENDING UPON THE ENVIRONMENT IN WHICH THE SYSTEM IS USED.

DO NOT OPERATE THE NOTEBOOK IN AREAS WHERE THE AIR VENTS CAN BE OBSTRUCTED, SUCH AS IN TIGHT ENCLOSURES OR ON SOFT SURFACES LIKE A BED OR CUSHION.

External Video Port

The external video port allows you to connect an external monitor or LCD projector. See “External Video Port” on page 65.

DC Power Jack

The DC power jack allows you to plug in the AC adapter or the optional Auto/Airline adapter to power your system and charge the internal Lithium ion Battery.

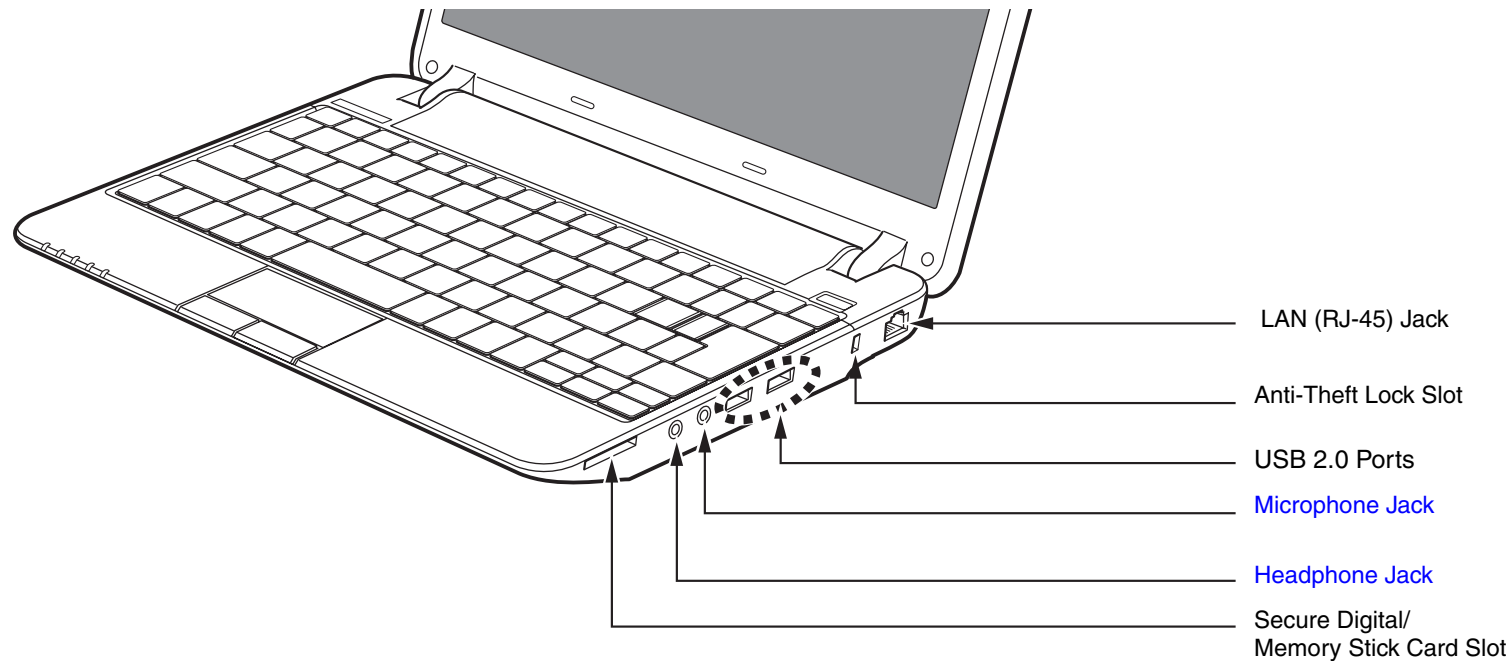

Figure 4. P3010 LifeBook right-side panel

Right-Side Panel Components

The following is a brief description of your notebook's right-side components.

LAN (RJ-45) Port

The internal LAN (RJ-45) port is used for an internal 10/100 Base-Tx Ethernet. See "Universal Serial Bus Ports" on page 65.

Anti-theft Lock Slot

The anti-theft lock slot allows you to attach a optional physical lock-down device.

USB 2.0 Ports

The three USB 2.0 ports (one on the left side, two on the right side) allow you to connect Universal Serial Bus devices. USB 2.0 transfers data at up to 480 Mbps and is backward-compatible with USB 1.1 devices, which transfer data at up to 12 Mbps. See “Universal Serial Bus Ports” on page 65.

Microphone Jack

The microphone jack allows you to connect an external mono microphone. See “Microphone Jack” on page 65.

Headphone Jack

The headphone jack allows you to connect stereo headphones or powered external speakers. See “External Video Port” on page 65.

Secure Digital/Memory Stick Card Slot

The Secure Digital/Memory Stick (SD/MS) card slot allows you to insert a flash memory card for data storage. Flash memory cards allow you to transfer data to and from a variety of different digital devices.

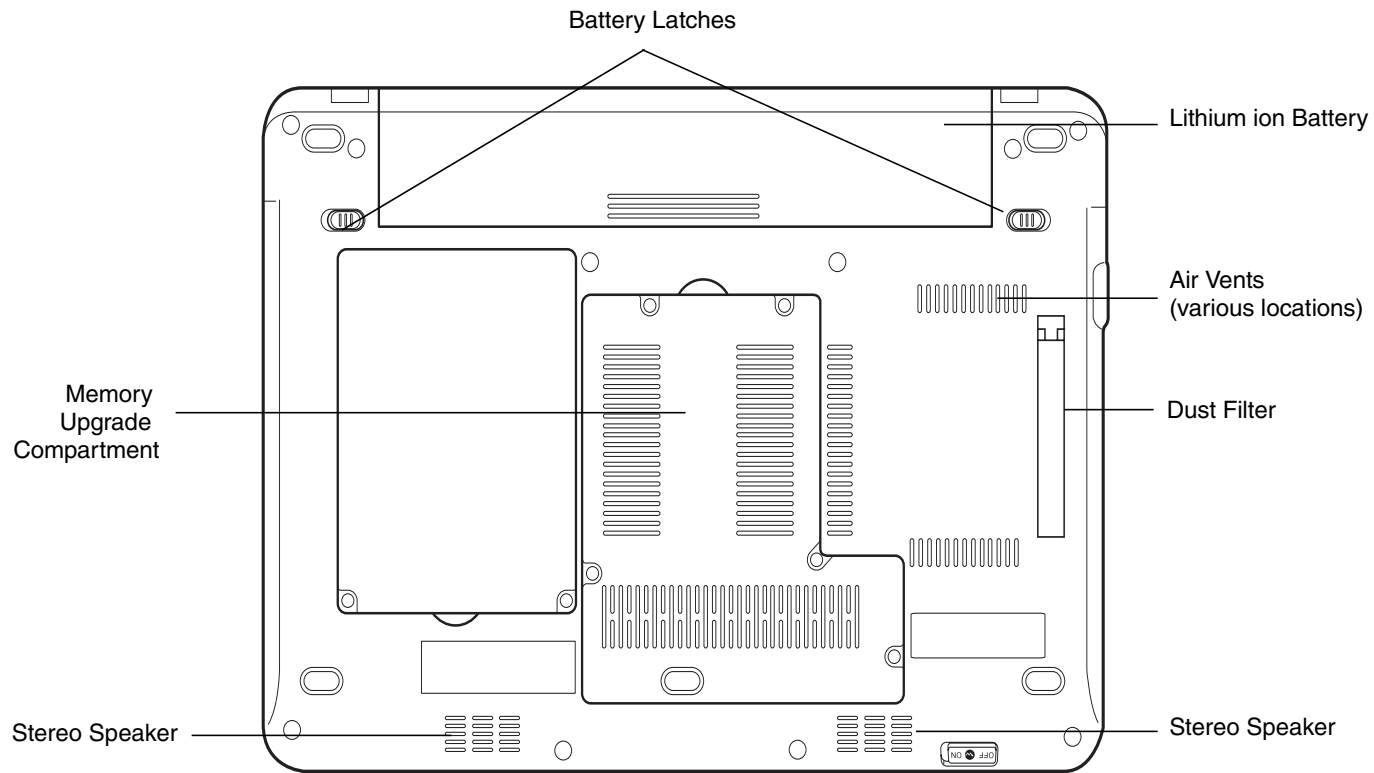

Figure 5. P3010 LifeBook bottom panel

Bottom Components

The following is a brief description of your notebook's bottom panel components.

Battery Latches

The battery latches are used to secure the Lithium ion battery in the battery bay.

Lithium ion Battery Bay

The battery compartment contains the Lithium ion battery. The battery should be removed when the computer is stored over a long period of time or for swapping a discharged battery with a charged Lithium ion battery. See “Lithium ion Battery” on page 53.

Air Vents

The air vents allow air to circulate through the system to cool down the components.



TO PROTECT YOUR NOTEBOOK FROM DAMAGE AND TO OPTIMIZE SYSTEM PERFORMANCE, BE SURE TO **KEEP ALL AIR ALL VENTS UNOBSTRUCTED, CLEAN, AND CLEAR OF DEBRIS**. THIS MAY REQUIRE PERIODIC CLEANING, DEPENDING UPON THE ENVIRONMENT IN WHICH THE SYSTEM IS USED.

DO NOT OPERATE THE NOTEBOOK IN AREAS WHERE THE AIR VENTS CAN BE OBSTRUCTED, SUCH AS IN TIGHT ENCLOSURES OR ON SOFT SURFACES LIKE A BED OR CUSHION.

Dust Filter

Stereo Speakers

The speakers allows you to listen to stereo sound from your system.

Memory Upgrade Compartment

Your notebook comes with high speed DDR2 Synchronous Dynamic RAM (SDRAM). The memory upgrade compartment allows you to expand the system memory capacity of your system, hence improving overall performance. See “Memory Upgrade Module” on page 58.

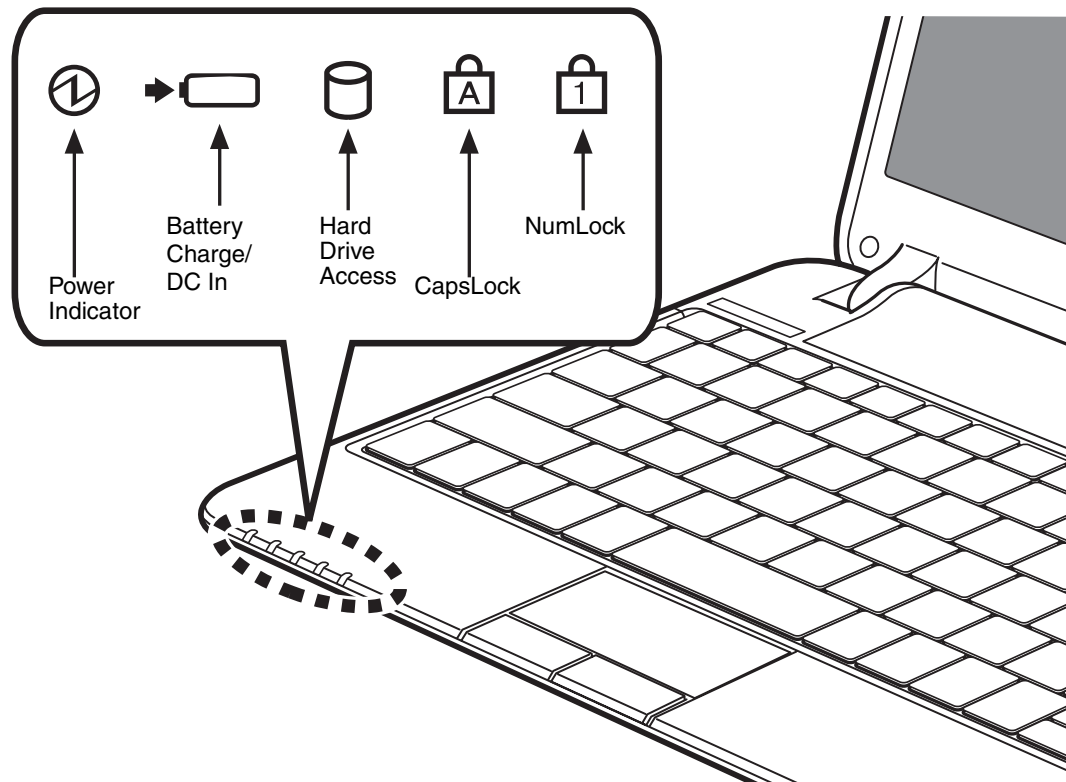

Figure 6. Status Indicator Panel

Status Indicator Panel

The status indicators display symbols that correspond to specific components of your notebook. (Figure 6) The symbols show how each of those components is operating. Note that there are two locations that contain status indicators: above the keyboard and on the front edge of the notebook.



Power Indicator

The Power indicator symbol located on the power button shows whether your system is operational. When it is solid blue, it means that there is power to your computer and that it is ready for use.



Battery Charge/DC-In Indicator

Depending upon whether you have an AC adapter connected or not, the battery indicator will appear in a variety of colors and states.

AC Adapter connected...	
Solid blue	Charge complete
Solid orange	Charging in process
Purple, blinking	Battery malfunction
No AC Adapter connected...	
Orange, blinking	Battery is charged 12% or less.
Purple, blinking	Battery malfunction
Off	Battery charge between 13% and 100% Battery completely discharged No battery installed

Table 1. Battery indicator states



BATTERIES SUBJECTED TO SHOCKS, VIBRATION OR EXTREME TEMPERATURES CAN BE PERMANENTLY DAMAGED.



Hard Drive Access Indicator

The Hard Drive Access indicator lights green when your internal hard drive is being accessed.



CapsLock Indicator

The CapsLock indicator shows that your keyboard is set to type in all capital letters.



NumLk Indicator

The NumLk indicator shows that the integral keyboard is set in ten-key numeric keypad mode.

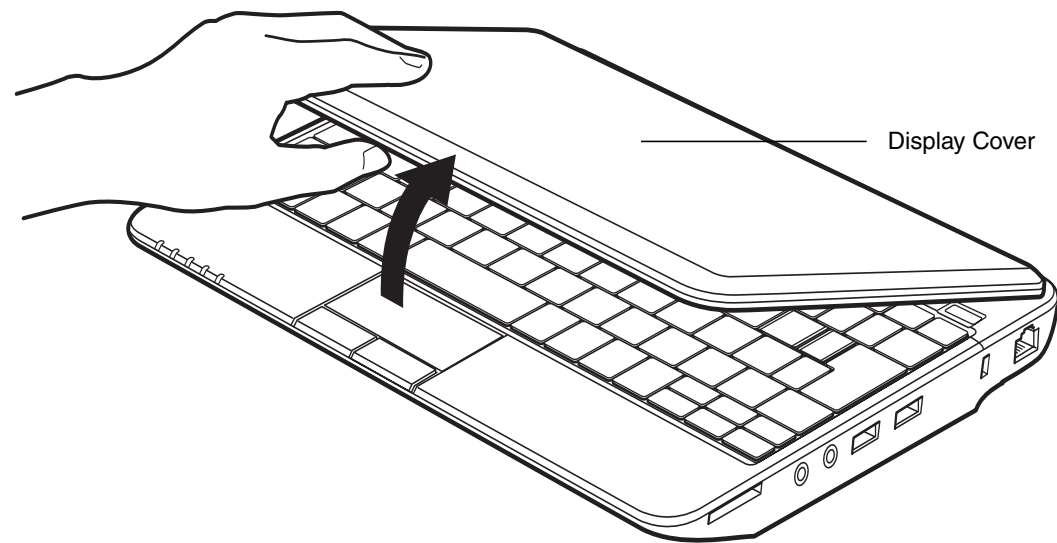

Figure 2. Opening the Display Panel

Display Panel

Your Fujitsu notebook contains a display panel that is backlit for easier viewing in bright environments.

Opening the Display Panel

Lift the display backwards, being careful not to touch the screen with your fingers, until it is at a comfortable viewing angle. (*Figure 2*)

Adjusting Display Panel Brightness

Once you have turned on your system, you may want to adjust the brightness level of the screen to a more comfortable viewing level. There are two ways to adjust the brightness: keyboard and power management utility.



NOTE THAT WHEN YOU CHANGE THE DISPLAY SETTINGS, THE CHANGES WILL BE RETAINED AFTER SLEEP AND RESTART.

Using the Keyboard to Adjust Brightness

Use the following key combinations to adjust the screen brightness:

- [Fn+F6]: Pressing repeatedly will lower the brightness of your display.
- [Fn+F7]: Pressing repeatedly will increase the brightness of the display.

Using Power Management to Adjust Brightness

To adjust brightness with the power management utility, click Start > Control Panel (Classic View) > Brightness Control. Set the screen brightness slider for battery and AC power scenarios.



IF USING AC POWER, YOUR BRIGHTNESS SETTING IS SET TO ITS HIGHEST LEVEL BY DEFAULT. IF USING BATTERY POWER, YOUR BRIGHTNESS SETTING IS SET TO APPROXIMATELY MID-LEVEL BY DEFAULT.

THE HIGHER THE BRIGHTNESS LEVEL, THE MORE POWER THE NOTEBOOK WILL CONSUME AND THE FASTER YOUR BATTERIES WILL DISCHARGE. FOR MAXIMUM BATTERY LIFE, MAKE SURE THAT THE BRIGHTNESS IS SET AS LOW AS POSSIBLE.

Keyboard

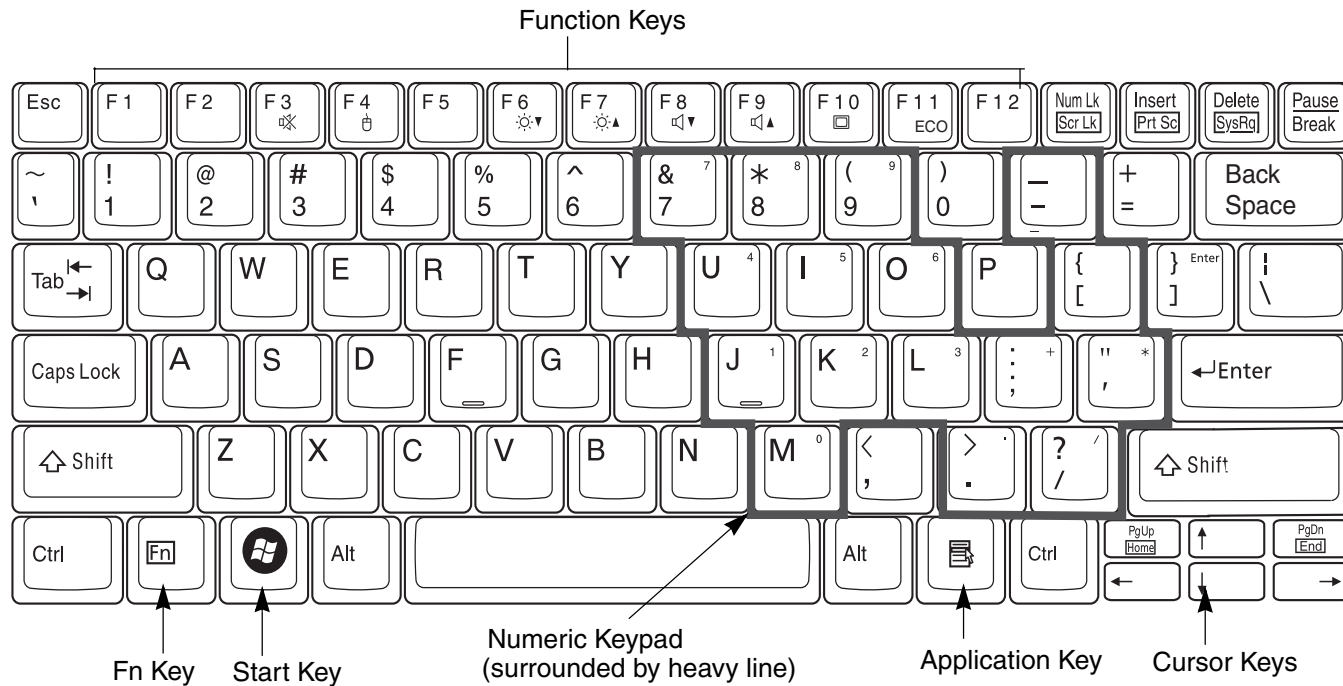

Figure 3. Keyboard

Using the Keyboard

Your P3010 notebook has an integral 84-key keyboard. The keys perform all the standard functions of a 101-key keyboard, including the Windows keys and other special function keys. This section describes the following keys. (Figure 3)

- **Numeric keypad:** Your system allows certain keys to serve dual purposes, both as standard characters and as numeric and mathematical keys. The ability to toggle between the standard character and numerical keys is controlled through the [NumLk] key.

- **Cursor keys:** Your keyboard contains four arrow keys for moving the cursor or insertion point to the right, left, up, or down within windows, applications and documents.
- **Function keys:** The keys labeled [F1] through [F11/F12], are used to produce special actions that vary depending on what program is running. They are also used in conjunction with the [Fn] key to perform certain tasks, as detailed below under “Function Keys”.
- **Windows keys:** These keys work with your Windows operating system and function the same as the onscreen Start menu button, or the right button on your pointing device.

Numeric Keypad

Certain keys on the keyboard perform dual functions as both standard character keys and numeric keypad keys. NumLk can be activated by pressing the [NumLk] key. Turning off the NumLk feature is done the same way. Once this feature is activated you can enter numerals 0 through 9, perform addition (+), subtraction (-), multiplication (*), or division (/), and enter decimal points (.) using the keys designated as ten-key function keys. The keys in the numeric keypad are marked on the front edge of the key to indicate their secondary functions. (Figure 3)

Windows Keys

Your P3010 notebook has two Windows keys: a Start key and an Application key. The Start key displays the Start menu. This button functions the same as your onscreen Start menu button. The Application key functions the same as your right mouse button and displays shortcut menus for the selected item. (Please refer to your Windows documentation for additional information regarding the Windows keys.) (Figure 3)

Cursor Keys

The cursor keys are the four arrow keys on the keyboard which allow you to move the cursor up, down, left and right in applications. In programs such as Windows Explorer, it moves the “focus” (selects the next item up, down, left, or right).

Function Keys

Your notebook has 11 function keys, F1 through F11/F12. The functions assigned to these keys differ for each application.

- [Fn+F3]: Pressing [F3] while holding [Fn] will toggle the Audio Mute on and off.
- [Fn +F4]: Pressing [F4] while holding [Fn] allows you to toggle the mouse on and off.
- [Fn+F6]: Pressing [F6] repeatedly while holding [Fn] will lower the brightness of your display. Note that adjusting the brightness using the keyboard changes the system setting.
- [Fn+F7]: Pressing [F7] repeatedly while holding [Fn] will increase the brightness of the display.
- [Fn+F8]: Pressing [F8] repeatedly while holding [Fn] will decrease the volume of your system.
- [Fn+F9]: Pressing [F9] repeatedly while holding [Fn] will increase the volume of your system.
- [Fn+F10]: Pressing [F10] while holding [Fn] allows you to change your selection of where to send your display video. Each time you press the combination of keys you will step to the next choice. The choices, in order, are: built-in display panel only, external monitor only, and both built-in display panel and external monitor.
- [Fn +F11]: Pressing [F11] while holding the [Fn] (ECO) key will help to extend system power by reducing the LCD brightness, shutting down the optical drive, and enabling the hard disk drive's auto power off mode.

Touchpad Pointing Device

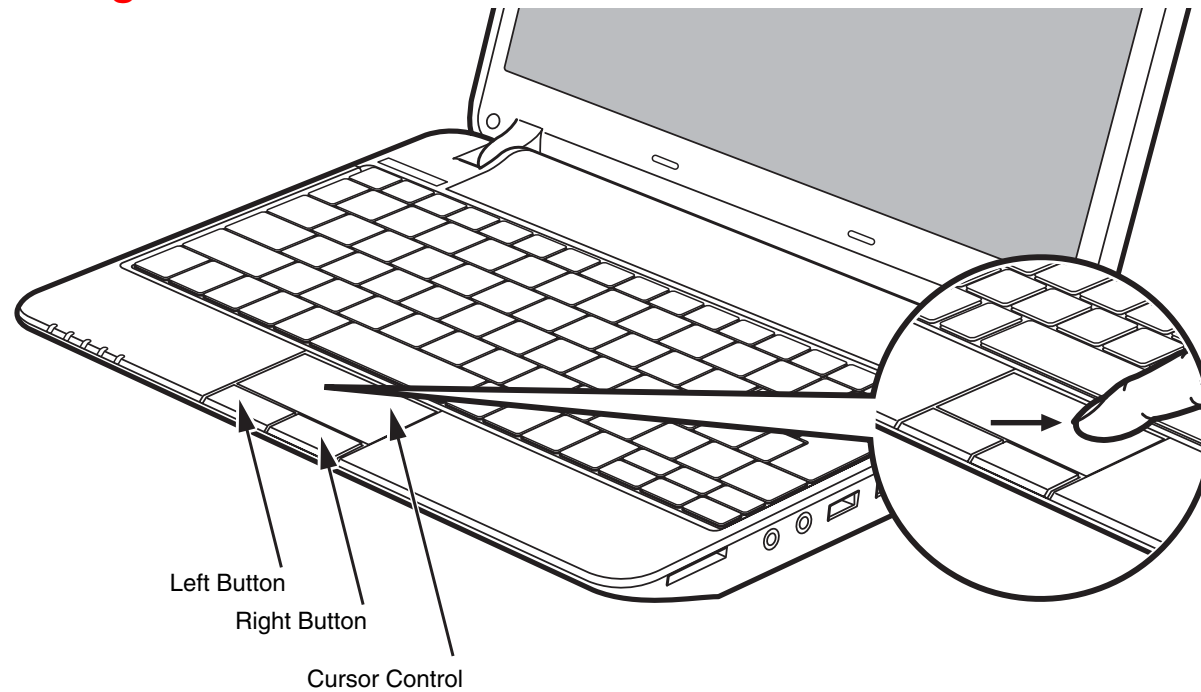

Figure 4. Touchpad pointing device

The Touchpad pointing device comes built into your Fujitsu notebook. It is used to control the movement of the pointer to select items on your display panel. The Touchpad is composed of a cursor control, a left button and a right button. The cursor control works the same way a mouse does, and moves the cursor around the display. It only requires light pressure with the tip of your finger. The left and right buttons function the same as mouse buttons. The actual functionality of the buttons may vary depending on the application that is being used.



AN EXTERNAL MOUSE CAN BE CONNECTED TO THE USB PORTS ON YOUR NOTEBOOK AND USED SIMULTANEOUSLY WITH THE TOUCHPAD. HOWEVER, IF YOU BOOT THE SYSTEM WITH AN EXTERNAL MOUSE CONNECTED THE TOUCHPAD WILL BE DISABLED OR ENABLED DEPENDING ON THE SPECIFICATIONS IN YOUR BIOS SETTINGS. See “*BIOS Setup Utility*” on page 44.

Clicking

Clicking means pushing and releasing a button. To left-click, move the cursor to the item you wish to select, press the left button once, and then immediately release it. To right-click, move the mouse cursor to the item you wish to select, press the right button once, and then immediately release it. You also have the option to perform the clicking operation by tapping lightly on the Touchpad once.

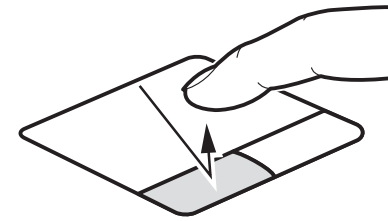

Figure 5. Clicking with button

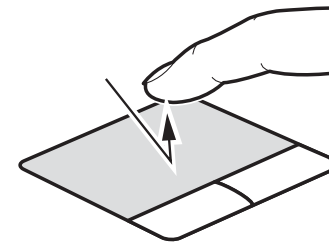

Figure 6. Clicking with Touchpad

Double-Clicking

Double-clicking means pushing and releasing the left button twice in rapid succession. This procedure does not function with the right button. To double-click, move the cursor to the item you wish to select, press the left button twice, and immediately release it. You can also perform the double-click operation by tapping lightly on the Touchpad twice.

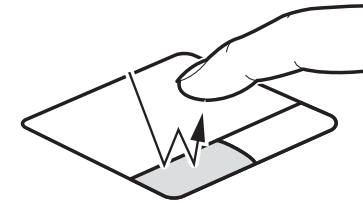

Figure 7. Double-clicking with button

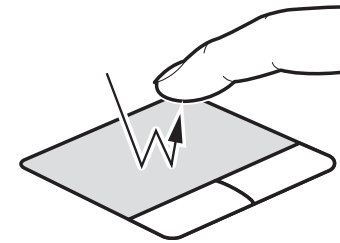

Figure 8. Double-clicking with Touchpad

Dragging

Dragging means pressing and holding the left button, while moving the cursor. To drag, move the cursor to the item you wish to move. Press and hold the left button while moving the item to its new location and then release it. Dragging can also be done using the Touchpad. First, tap the Touchpad twice over the item you wish to move making sure to leave your finger on the pad after the final tap. Next, move the object to its new location by moving your finger across the Touchpad, and then release your finger.

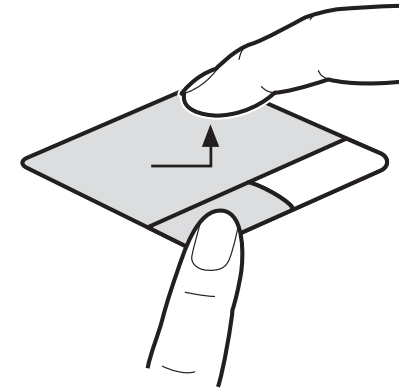

Figure 9. Dragging

Touchpad Control Adjustment

The Windows Control Panel allows you to customize your Touchpad with selections made from within the Mouse Properties dialog box.

Volume Control

Your Fujitsu notebook has multiple volume controls which interact with each other.



ANY SOFTWARE THAT CONTAINS AUDIO FILES WILL ALSO CONTAIN A VOLUME CONTROL OF ITS OWN. IF YOU INSTALL AN EXTERNAL AUDIO DEVICE THAT HAS AN INDEPENDENT VOLUME CONTROL, THE HARDWARE VOLUME CONTROL AND THE SOFTWARE VOLUME CONTROL WILL INTERACT WITH EACH OTHER. IT SHOULD BE NOTED THAT IF YOU SET YOUR SOFTWARE VOLUME TO OFF, YOU WILL OVERRIDE THE EXTERNAL VOLUME CONTROL SETTING.

Controlling the Volume

The volume can be controlled in several different ways:

- Volume can be set from within the Volume Control in the Notification Area at the bottom right of your screen.
- Volume can be controlled with the [F8] and [F9] functions keys. Pressing [F8] repeatedly while holding [Fn] will decrease the volume of your notebook. Pressing [F9] repeatedly while holding [Fn] will increase the volume of your notebook.
- Volume can be changed by opening the Control Panel and selecting Windows Mobility Center. From there, you can either mute or adjust the sound in the Volume area.
- Volume can be controlled by many volume controls that are set within individual applications.
- Certain external audio devices you might connect to your system may have hardware volume controls.

Each source discussed above puts an upper limit on the volume level that must then be followed by the other sources. We recommend that you experiment with the various volume controls to discover the optimal sound level.

Chapter 2

Getting Started with Your Notebook

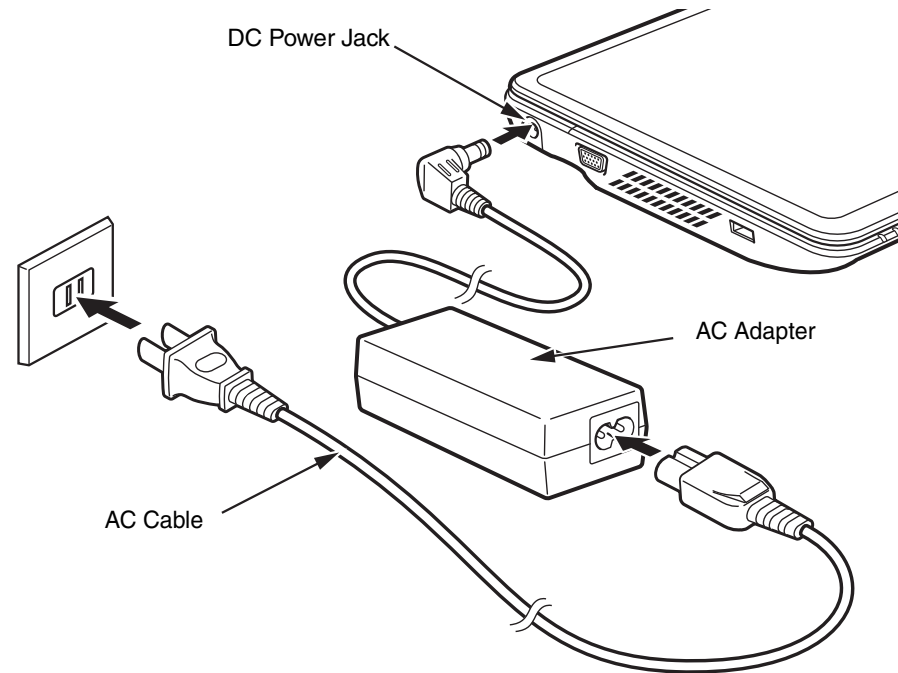

Figure 10. Connecting the AC Adapter

Power Sources

Your Fujitsu notebook has three possible power sources: a primary Lithium ion battery, an AC adapter or an optional Auto/Airline adapter.

Connecting the Power Adapters

The AC adapter or optional Auto/Airline adapter provides power for operating your notebook and charging the batteries.

Connecting the AC Adapter

- 1 Plug the DC output cable into the DC power jack of your notebook.
- 2 Plug the AC adapter into an AC electrical outlet.

Connecting the Optional Auto/Airline Adapter

- 1 Plug the DC output cable into the DC power jack on your notebook.
- 2 Plug the Auto/Airline adapter into the cigarette lighter of an automobile with the ignition key in the On or Access OR
- 3 Plug the Auto/Airline adapter into the DC power jack on an airplane seat.

Switching from AC Adapter Power or the Auto/Airline Adapter to Battery Power

- 1 Be sure that you have at least one charged battery installed.
- 2 Remove the AC adapter or the Auto/Airline adapter.



THE LITHIUM ION BATTERY IS NOT CHARGED UPON PURCHASE. INITIALLY, YOU WILL NEED TO CONNECT EITHER THE AC ADAPTER OR THE AUTO/AIRLINE ADAPTER TO USE YOUR NOTEBOOK.

Starting Your P3010 LifeBook

Power On

Power/Suspend/Resume Button

The Power/Suspend/Resume button is used to turn on your notebook from its off state. Once you have connected your AC adapter or charged the internal Lithium ion battery, you can power on your notebook.



WHEN YOU TURN ON YOUR NOTEBOOK BE SURE YOU HAVE A POWER SOURCE. THIS MEANS THAT AT LEAST ONE BATTERY IS INSTALLED AND CHARGED, OR THAT THE AC OR AUTO/AIRLINE ADAPTER IS CONNECTED AND HAS POWER.

To turn on your notebook from its off state, press the Power/Suspend/Resume button, located above the keyboard to the right. When you are done working you can either leave your notebook in Suspend mode, See “Standby Mode” on page 49. or you can turn it off. See “Powering Off” on page 51..



DO NOT CARRY YOUR NOTEBOOK AROUND WITH THE POWER ON OR SUBJECT IT TO SHOCKS OR VIBRATION, AS YOU RISK DAMAGING YOUR NOTEBOOK.

When you power on your notebook, it will perform a Power On Self Test (POST) to check the internal parts and configuration for correct functionality. If a fault is found, your notebook will emit an audio warning and/or an error message will be displayed. See “Power On Self Test Messages” on page 77. Depending on the nature of the problem, you may be able to continue by starting the operating system or by entering the BIOS setup utility and revising the settings.

After satisfactory completion of the POST, your notebook will load your operating system.



NEVER TURN OFF YOUR NOTEBOOK DURING THE POWER ON SELF TEST (POST) OR IT WILL CAUSE AN ERROR MESSAGE TO BE DISPLAYED WHEN YOU TURN YOUR NOTEBOOK ON THE NEXT TIME. See “Power On Self Test Messages” on page 77.

Boot Sequence

The procedure for starting-up your notebook is termed the Bootup sequence and involves your notebook’s BIOS. When your notebook is first turned on, the main system memory is empty, and it needs to find instructions to start up your notebook. This information is in the BIOS program. Each time you power up or restart your notebook, it goes through a boot sequence which displays a Fujitsu logo until your operating system is found. During booting, your notebook is performing a standard boot sequence including a Power On Self Test (POST). When the boot sequence is completed without a failure and without a request for the BIOS Setup Utility, the system displays the operating system’s opening screen.

The boot sequence is executed when:

- You turn on the power to your notebook.
- You restart your notebook from the Windows Shut Down dialog box.
- The software initiates a system restart. Example: When you install a new application.

BIOS Setup Utility

The BIOS Setup Utility is a program that sets up the operating environment for your notebook. Your BIOS is set at the factory for normal operating conditions, therefore there is no need to set or change the BIOS’ environment to operate your notebook.

The BIOS Setup Utility configures:

- Device control feature parameters, such as changing boot devices.
- System Data Security feature parameters, such as passwords.

Entering the BIOS Setup Utility

To enter the BIOS Setup Utility do the following:

- 1 Turn on or restart your notebook.
- 2 To enter the BIOS Setup Utility, press the [F2] key once the Fujitsu logo appears on the screen. This will open the main menu of the BIOS Setup Utility with the current settings displayed.
- 3 Press the [RIGHT ARROW] or [LEFT ARROW] key to scroll through the other setup menus to review or alter the current settings.

The Boot Menu can also be invoked by pressing the [F11] key when the Fujitsu logo appears on the screen.

Setting the Supervisor Password and Password on Boot Settings

- 1 Enter the BIOS Setup Utility.
- 2 Scroll to the Security Tab.
- 3 Select **Set Supervisor Password**, press [ENTER].
- 4 Enter New Password and confirm new password.
- 5 In the Security Tab, scroll to **Password on Boot**, and press [ENTER].
- 6 Press [F10]. The **Save and Exit**, a screen will pop up. If you are finished making changes, select **Yes** and press [ENTER].

BIOS Guide

A guide to your notebook's BIOS is available online. Please visit our service and support website at <http://www.computers.us.fujitsu.com/support>, then select User's Guides under Online Support. Select your Product, Series, and Model, then click [Go]. Under the Manuals tab, select the BIOS Guide.

Booting the System

We strongly recommend that you not attach any external devices until you have gone through the initial power on sequence.

When you turn on your notebook for the first time, it will display a Fujitsu logo on the screen. If you do nothing the system will load the operating system, and then the Windows Welcome will begin.

Starting Windows the First Time

Registering with Microsoft

In order to ensure that you receive the most benefits from the Windows operating system, it should be registered the first time you use it.

After you receive the Windows Welcome screen, you will be prompted to enter registration information in the following order.

First of all, you will need to read and accept the End User License Agreements (EULAs). After accepting the EULAs, you will be asked if you want to enable the Automatic Updates feature. Acceptance of this feature is recommended because it allows your system to be updated automatically whenever an important change becomes available for your notebook.



- IF YOU REJECT THE TERMS OF THE LICENSE AGREEMENT YOU WILL BE ASKED TO REVIEW THE LICENSE AGREEMENT FOR INFORMATION ON RETURNING WINDOWS OR TO SHUT DOWN YOUR NOTEBOOK.
- YOU CANNOT USE YOUR NOTEBOOK UNTIL YOU HAVE ACCEPTED THE LICENSE AGREEMENT. IF YOU STOP THE PROCESS YOUR NOTEBOOK WILL RETURN TO THE BEGINNING OF THE WINDOWS WELCOME PROCESS, EVEN IF YOU SHUT YOUR NOTEBOOK DOWN AND START IT UP AGAIN.

Several additional windows will appear, prompting you to enter a name and description for your computer, an Administrator password, and a domain name. Read the instructions on the screens carefully and fill in the information as directed.

You will then be automatically connected to the Internet, if you have an appropriate connection available. If an automatic connection is not possible, you will be asked about how you dial out from where you will be using your notebook. If you are not connected to a phone line and plan to register at a later time, you may click the **Skip** button.

Once you are connected to the Internet, you will be asked if you wish to continue with the registration. If you select **Yes** you will then enter your name and address, and email address if desired. Click **Next** to complete registration.

Registering your notebook with Fujitsu

You can register your notebook by going to our website at: **us.fujitsu.com/computers**. You will need to be set up with an Internet Service Provider (ISP) to register online.



Installing ClickMe!



BEFORE INSTALLING THE CLICKME! UTILITY, BE SURE THE WIRELESS LAN DEVICE IS ENABLED BY PRESSING THE [FN] + [F5] KEY COMBINATION.

The first time you boot up your system, you will see an icon called Click Me! in the Start menu. **We highly recommend that you install the ClickMe! utility the first time you boot up.** When you click the Click Me! icon, your system will automatically create the related icons in the system tray in the bottom right of the screen. These icons provide links to utilities that you will frequently access, such as wireless LAN software provided by the wireless LAN manufacturer.



THERE MAY BE SOME THIRD-PARTY APPLICATIONS THAT DO NOT GET INSTALLED USING THE CLICKME! UTILITY. FOR MORE INFORMATION, REFER TO YOUR GETTING STARTED GUIDE.



Fujitsu Driver Update Utility

Your system has a convenient tool called the Fujitsu Driver Update (FDU) utility. With FDU, you can choose to automatically or manually go to the Fujitsu site to check for new updates for your system. For more information about the FDU utility, refer to “Automatically Downloading Driver Updates” on page 82.

Power Management

Your notebook has many options and features for conserving battery power. Some of these features are automatic and need no user intervention. However, others depend on the parameters you set to best suit your operating conditions, such as those for the display brightness. Internal power management for your notebook may be controlled from settings made in your operating system, pre-bundled power management application, or from settings made in BIOS setup utility.

Besides the options available for conserving battery power, there are also some things that you can do to prevent your battery from running down as quickly. For example, you can create an appropriate power saving profile, put your notebook into standby mode when it is not performing an operation, and you can limit the use of high power devices. As with all mobile, battery powered computers, there is a trade-off between performance and power savings.

Power/Suspend/Resume Button

When your notebook is active, the Power/Suspend/Resume button can be used to manually put the notebook into standby mode. Push the Power/Suspend/Resume button when the notebook is active, but not actively accessing anything, and immediately release the button.

If your notebook is suspended, pushing the Power/Suspend/Resume button returns your notebook to active operation. You can tell whether the system is Suspended by looking at the Power indicator. If the indicator is visible and not flashing, your notebook is fully operational. If the indicator is visible *and* flashing, your notebook is in standby mode. If the indicator is not visible, the power is off or your notebook is in Hibernation mode. (*See Hibernation Feature*)

Standby Mode

Standby mode in Windows saves the contents of your system memory during periods of inactivity by maintaining power to critical parts. This mode turns off the CPU, display, hard drive, and all other internal components except those necessary to maintain system memory and for restarting.

Your notebook can be put in Standby mode by:

- Pressing the Power/Suspend/Resume button when your system is turned on.
- Selecting Standby from the **Turn off computer** menu.
- Timing out from lack of activity.
- Allowing the battery to reach the Dead Battery Warning condition.

Your notebook's system memory typically stores the file on which you are working, open application information, and any other data required to support operations in progress. When you resume operation from Standby mode, your notebook will return to the point where it left off. You must use the Power/Suspend/Resume button to resume operation, and there must be an adequate power source available, or your notebook will not resume.



- IF RUNNING YOUR NOTEBOOK ON BATTERY POWER, BE AWARE THAT THE BATTERY CONTINUES TO DISCHARGE WHILE YOUR NOTEBOOK IS IN STANDBY MODE, THOUGH NOT AS FAST AS WHEN FULLY OPERATIONAL.
- DISABLING THE POWER/SUSPEND/RESUME BUTTON PREVENTS IT FROM BEING USED TO PUT THE NOTEBOOK INTO SLEEP OR HIBERNATION (SAVE-TO-DISK) MODE. THE BUTTON RESUME FUNCTION CAN'T BE DISABLED.
- THE SLEEP OR HIBERNATION (SAVE-TO-DISK) MODE SHOULD NOT BE USED WITH CERTAIN PC CARDS. CHECK YOUR PC CARD DOCUMENTATION FOR MORE INFORMATION. WHEN PC CARDS OR EXTERNAL DEVICES ARE IN USE, HIBERNATION (SAVE-TO-DISK) MODE CANNOT RETURN TO THE EXACT STATE PRIOR TO SUSPENSION, BECAUSE ALL OF THE PERIPHERAL DEVICES WILL BE RE-INITIALIZED WHEN THE SYSTEM RESTARTS.
- IF YOUR NOTEBOOK IS ACTIVELY ACCESSING INFORMATION WHEN YOU ENTER STANDBY OR HIBERNATION MODE, CHANGES TO OPEN FILES ARE NOT LOST. FILES ARE LEFT OPEN AND MEMORY IS KEPT ACTIVE DURING STANDBY MODE OR THE MEMORY IS TRANSFERRED TO THE INTERNAL HARD DRIVE DURING HIBERNATION MODE.
- THE MAIN ADVANTAGE OF USING HIBERNATION IS THAT POWER IS NOT REQUIRED TO MAINTAIN YOUR DATA. THIS IS PARTICULARLY IMPORTANT IF YOU WILL BE LEAVING YOUR NOTEBOOK IN A SUSPENDED STATE FOR A PROLONGED PERIOD OF TIME. THE DRAWBACK OF USING HIBERNATION MODE IS THAT IT LENGTHENS THE POWER DOWN AND POWER UP SEQUENCES AND RESETS PERIPHERAL DEVICES.

Hibernation (Save-to-Disk) Feature

The Hibernation feature saves the contents of your notebook's system memory to the hard drive as a part of the Suspend/Resume mode. You can enable or disable this feature.

Enable or Disable the Hibernation Feature

The default settings are not enabled. To enable or disable the Hibernation feature follow these steps:

- 1 From the Start menu, select Settings, and then select Control Panel.
- 2 From the Control Panel select Power Options.
- 3 Select the Hibernate tab. Select the box to enable or disable this feature.

Windows Power Management

The Power Options icon located in the Windows Control Panel allows you to configure some of the power management settings. For example, you can use the Power Options to set the timeout values for turning off the display and hard disks whether you are running the notebook on battery power or one of the adapters.

Restarting the System

If your system is on and you need to restart it, be sure that you use the following procedure.

- 1 Click the [Start] button, and then click Turn Off Computer.
- 2 Select the **Restart** option. Your notebook will shut down and then reboot.



TURNING OFF YOUR NOTEBOOK WITHOUT EXITING WINDOWS OR TURNING ON YOUR NOTEBOOK WITHIN 10 SECONDS OF THE NOTEBOOK BEING SHUT OFF MAY CAUSE AN ERROR WHEN YOU START THE NEXT TIME.

Powering Off

Before turning off the power, check that the hard drive/optical drive access indicator is off. If you turn off the power while accessing a disk there is a risk of data loss. To ensure that your notebook shuts down without error, use the Windows shut down procedure.



BE SURE TO CLOSE ALL FILES, EXIT ALL APPLICATIONS, AND SHUT DOWN YOUR OPERATING SYSTEM PRIOR TO TURNING OFF THE POWER. IF FILES ARE OPEN WHEN YOU TURN THE POWER OFF, YOU WILL LOSE ANY CHANGES THAT HAVE NOT BEEN SAVED, AND MAY CAUSE DISK ERRORS.

Using the correct procedure to shut down from Windows allows your notebook to complete its operations and turn off power in the proper sequence to avoid errors. The proper sequence is:

- 1 Click the [Start] button, and then click Turn Off Computer.
- 2 Select the **Turn Off** option.

If you are going to store your notebook for a month or more, see Care and Maintenance Section.

ENERGY STAR® Compliance



Your Fujitsu system is an ENERGY STAR® qualified mobile PC. By choosing a computer with the latest energy-saving technology, you're helping to preserve our environment for future generations.

ENERGY STAR is a joint program of the U.S. Environmental Protection Agency, U.S. Department of Energy, Natural Resources Canada, and other governments around the world helping us save money while protecting the environment through energy efficient products and practices. With energy costs and global warming top-of-mind for consumers, Fujitsu is committed to offering solutions that help consumers conserve energy and improve the quality of our environment.

Sleep Mode:

You will notice that your computer is initially set so that the display turns off after 15 minutes of user inactivity, and the computer goes into Sleep mode after 20 minutes of user inactivity. When going into Sleep mode, the computer also reduces the speed of any active Ethernet network links. To “wake” the computer from Sleep mode, press the Suspend/Resume Button.

Energy saving benefits:

Fujitsu ENERGY STAR qualified mobile PCs use about half as much electricity as standard equipment – saving half in utility costs. But more than that, ENERGY STAR also makes a difference for the environment. Did you know that the average house can be responsible for twice the greenhouse gas emissions as the average car? That's because every time you flip on a light switch, run your dishwasher, or turn on your PC, you use energy, which means more greenhouse gas emissions from power plants. So the more energy we can save through energy efficiency, the more we help to reduce greenhouse gases and the risks of global warming.

To learn more about the important ENERGY STAR program, visit: www.energystar.gov.

To read about how Fujitsu is supporting Sustainable Management along with several other environmental activities, visit the Fujitsu Corporate Citizenship page at:

<http://www.computers.us.fujitsu.com/www/content/aboutus/environmental/environment.php>

Chapter 3

User-Installable Features

Lithium ion Battery

Your notebook has a Lithium ion battery that provides power for operating your notebook when no external power source is available. The battery is durable and long lasting, but should not be exposed to extreme temperatures, high voltages, chemicals or other hazards.

The Lithium ion battery operating time may become shorter if it is used under the following conditions:

- When used at temperatures that exceed a low of 5°C or a high of 35°C. Extreme temperatures not only reduce charging efficiency, but can also cause battery deterioration. The Charging icon on the Status Indicator panel will flash when you try to charge a battery that is outside its operating temperature range.
- When using a high current device such as an external optical drive or the hard drive, using the AC adapter will conserve your battery life.



DO NOT LEAVE A FAULTY BATTERY IN YOUR NOTEBOOK. IT MAY DAMAGE YOUR AC ADAPTER, OPTIONAL AUTO/AIRLINE ADAPTER, ANOTHER BATTERY OR YOUR NOTEBOOK ITSELF. IT MAY ALSO PREVENT OPERATION OF YOUR NOTEBOOK BY DRAINING ALL AVAILABLE CURRENT INTO THE BAD BATTERY.



- ACTUAL BATTERY LIFE WILL VARY BASED ON SCREEN BRIGHTNESS, APPLICATIONS, FEATURES, POWER MANAGEMENT SETTINGS, BATTERY CONDITION AND OTHER CUSTOMER PREFERENCES. OPTICAL DRIVE OR HARD DRIVE USAGE MAY ALSO HAVE A SIGNIFICANT IMPACT ON BATTERY LIFE. THE BATTERY CHARGING CAPACITY IS REDUCED AS THE BATTERY AGES. IF YOUR BATTERY IS RUNNING LOW QUICKLY, YOU SHOULD REPLACE IT WITH A NEW ONE.
- UNDER FEDERAL, STATE, OR LOCAL LAW IT MAY BE ILLEGAL TO DISPOSE OF BATTERIES BY PUTTING THEM IN THE TRASH. PLEASE TAKE CARE OF OUR ENVIRONMENT AND DISPOSE OF BATTERIES PROPERLY. CHECK WITH YOUR LOCAL GOVERNMENT AUTHORITY FOR DETAILS REGARDING RECYCLING OR DISPOSING OF OLD BATTERIES. IF YOU CANNOT FIND THIS INFORMATION ELSEWHERE, CONTACT YOUR SUPPORT REPRESENTATIVE AT 1-800-8FUJITSU (1-800-838-5487)

Recharging the Batteries

If you want to know the condition of the primary Lithium ion battery, check the Battery Level indicator located on the Status Indicator panel. The indicator changes as the battery level changes. (See Table 1 on page 29 for more information.)

The Lithium ion battery is recharged internally using the AC adapter or Auto/Airline adapter. To recharge the battery make sure the battery that needs to be charged is installed in your notebook and connect the AC or Auto/Airline adapter.



MAKE SURE THAT THE BATTERY CHARGING INDICATOR AND THE BATTERY LEVEL INDICATOR ICON ON THE STATUS INDICATOR PANEL LIGHT.

There is no memory effect on the Lithium ion battery therefore you do not need to discharge the battery completely before recharging. The charge times will be significantly longer if your notebook is in use while the battery is charging. If you want to charge the battery more quickly, put your notebook into Standby mode, or turn it off while the adapter is charging the battery. *(See Power Management on page 48 for more information on Standby mode and shutdown procedure)*



USING HEAVY CURRENT DEVICES OR FREQUENT EXTERNAL OPTICAL DRIVE ACCESSES MAY PREVENT CHARGING COMPLETELY.

Low Battery State

When the battery is running low, the Battery Level indicator will glow red. If you do not respond to the low battery alarm, the batteries will continue to discharge until they are too low to operate. Your notebook will then go into Standby mode to try and protect your data for as long as possible. There is no guarantee that your data will not be lost once the system reaches this point.



- ONCE THE LOW BATTERY NOTIFICATION MESSAGE APPEARS, YOU NEED TO SAVE ALL YOUR ACTIVE DATA AND PUT YOUR NOTEBOOK INTO STANDBY MODE UNTIL YOU CAN PROVIDE A NEW POWER SOURCE. YOU SHOULD PROVIDE A CHARGED BATTERY, AN AC POWER ADAPTER, OR AUTO/AIRLINE ADAPTER AS SOON AS POSSIBLE.
- WHEN YOU ARE IN STANDBY MODE THERE MUST ALWAYS BE AT LEAST ONE POWER SOURCE ACTIVE. IF YOU REMOVE ALL POWER SOURCES WHILE YOUR NOTEBOOK IS IN STANDBY MODE, ANY DATA THAT HAS NOT BEEN SAVED TO THE HARD DRIVE WILL BE LOST.

Once your notebook goes into Dead Battery Suspend mode you will be unable to resume operation until you provide a source of power either from an adapter, or a charged battery. Once you have provided power, you will need to press the Suspend/Resume button to resume operation. In the Dead Battery Suspend mode, your data can be maintained for some time, but if a power source is not provided promptly, the Power indicator will stop flashing and go out, meaning that you have lost the data that was not stored. Once you provide power, you can continue to use your system while an adapter is charging the battery.

Replacing the Battery

Your notebook comes with one battery pack; you might want to consider purchasing a spare. By keeping a spare battery fully charged, you can immediately swap with one that is not charged.

There are two ways to swap batteries: cold- and hot-swapping. Cold-swapping means swapping batteries when the system is powered down; hot-swapping is performed when the system is powered by AC power:

Cold-swapping Batteries

- 1 Have a charged battery ready to install.
- 2 Shut down your system and disconnect the AC adapter.
- 3 Turn the system upside down on a secure surface.
- 4 Press the battery release latches to open the compartment.
- 5 Remove the battery from the compartment.
- 6 Slide the new battery into the compartment.
- 7 Close the compartment and the battery release latches will click into place.
- 8 Plug in the AC adapter and turn the power on.

Hot-swapping Batteries

To hot-swap batteries in your battery bay follow these easy steps:



BE SURE TO PLUG IN AN AC ADAPTER PRIOR TO REMOVING THE BATTERY. THERE IS NO BRIDGE BATTERY PRESENT TO SUPPORT THE SYSTEM WHILE THE BATTERY IS BEING REPLACED. IF YOU DO NOT USE AN AC ADAPTER YOU WILL LOSE ANY UNSAVED FILES.

- 1 Close any open files and put your system into Standby mode.
- 2 Connect an AC adapter or Auto/Airline power adapter to provide power to the system.
- 3 Turn the system upside down on a secure surface.
- 4 Press the battery release latches inward to open the compartment.
- 5 Remove the battery from the compartment.
- 6 Slide the new battery into the compartment.
- 7 Close the compartment and the battery release latches will click into place.
- 8 Press the Suspend/Resume button to return your system to normal operation.



IF THE LITHIUM ION BATTERY CONNECTOR IS NOT FULLY SEATED, YOU MAY NOT BE ABLE TO USE YOUR NOTEBOOK OR CHARGE YOUR BATTERY.

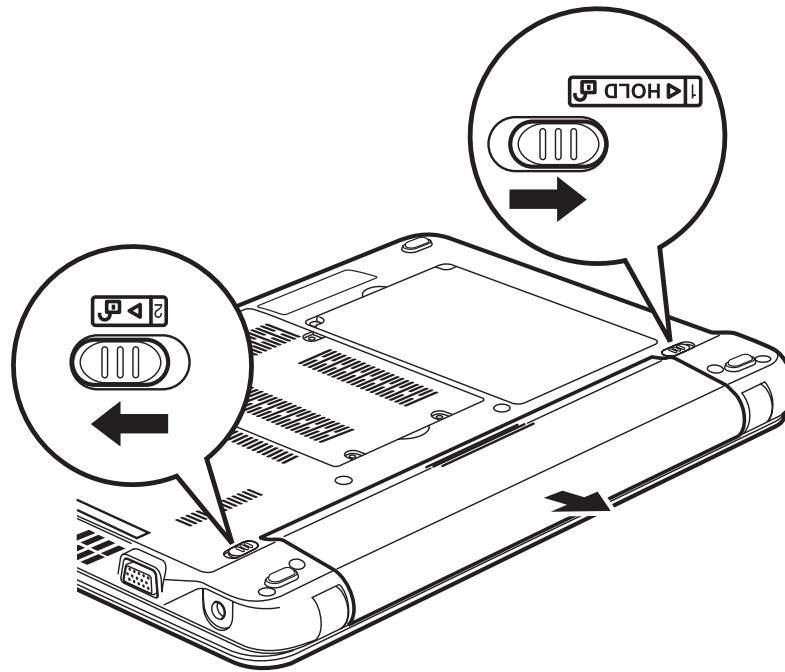

Figure 11. Removing a Battery

Memory Upgrade Module

Your Fujitsu P3010 notebook comes with 1GB of high speed Double Data Rate Synchronous Dynamic RAM 2 (DDR2 SDRAM), 533 MHz factory installed. To increase your system's memory capacity, you may remove the original module and replace it with a memory upgrade module. To ensure 100% compatibility, purchase the SDRAM module only from the Fujitsu web store at www.shopfujitsu.com.



- DO NOT REMOVE ANY SCREWS FROM THE MEMORY UPGRADE MODULE COMPARTMENT EXCEPT THE ONES SPECIFICALLY SHOWN IN THE DIRECTIONS FOR INSTALLING AND REMOVING THE MEMORY UPGRADE MODULE.
- THE MEMORY UPGRADE MODULE CAN BE SEVERELY DAMAGED BY ELECTROSTATIC DISCHARGE (ESD). TO MINIMIZE RISK TO THE MODULE, OBSERVE THE FOLLOWING PRECAUTIONS:
 - BEFORE HANDLING A MEMORY MODULE, TOUCH A GROUNDED METAL OBJECT TO DISCHARGE STATIC ELECTRICITY BUILT UP IN YOUR BODY.
 - WHEN INSTALLING OR REMOVING A MEMORY MODULE, HOLD IT BY THE EDGE SO AS NOT TO TOUCH ANY CONTACTS OR CHIPS. BE CAREFUL NOT TO TOUCH ANY INTERNAL COMPUTER TERMINALS OR COMPONENTS; THE OIL FROM YOUR FINGERS COULD CAUSE A SHORT TO THE COMPONENTS.
 - BE SURE TO POWER DOWN YOUR SYSTEM BEFORE ADDING OR REMOVING MEMORY MODULES. EVEN IF THE SYSTEM IS IN HIBERNATE OR SLEEP STATES, DATA COULD BE LOST OR THE MEMORY COULD BE DAMAGED IF POWER IS STILL AVAILABLE TO THE SYSTEM.

Removing Memory Modules

- 1** Turn off power to your notebook and remove any power adapter (AC or auto/airline).
- 2** Make sure that all the connector covers are closed.
- 3** Turn the system bottom side up, and remove the screws of the memory upgrade module compartment. (Figure 13).
- 4** Remove the cover.
- 5** Pull the clips sideways away from each side of the memory upgrade module at the same time. (Figure 13)
- 6** While holding the clips out, remove the module from the slot by lifting it up and pulling towards the rear of your notebook.

- 7** Store the memory module in a static guarded sleeve.
- 8** Install a new module as outlined in the procedure below.
- 9** Replace the cover.
- 10** Replace the screws.

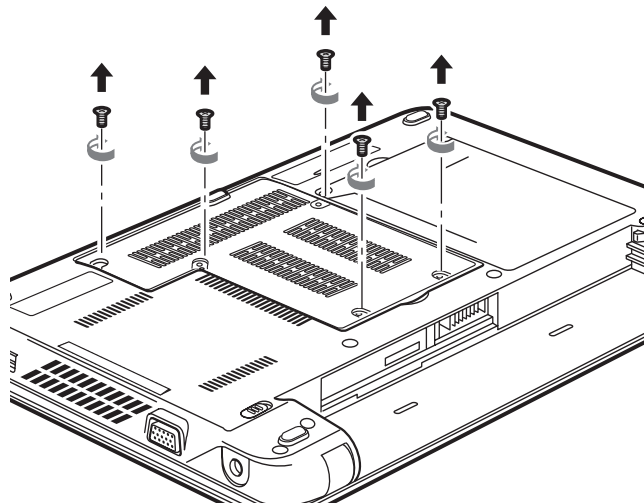

Figure 12. Opening the Memory Compartment

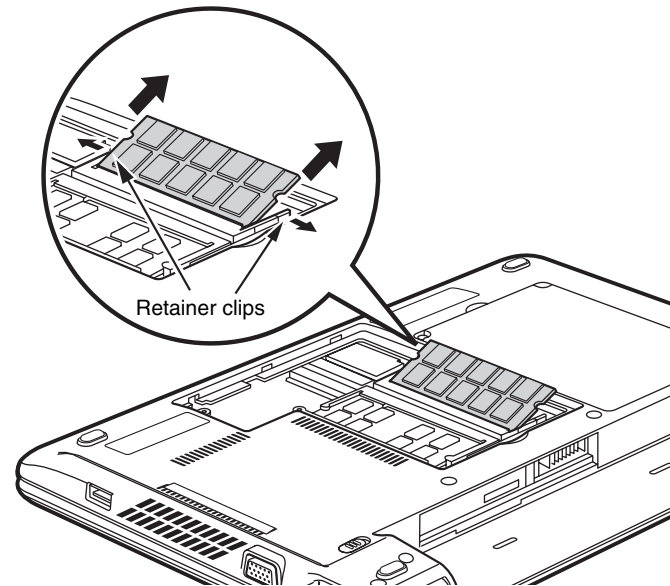

Figure 13. Removing a Memory Module

Installing a Memory Upgrade Module

- 1** Remove the new memory upgrade module from the static guarded sleeve.
- 2** Align the memory upgrade module with the component side up. Align the connector edge of the memory upgrade module with the connector slot in the compartment. (Figure 14)
- 3** Insert the memory upgrade module at a 45° angle. Press the connector edge of the module firmly down and into the connector until it lodges under the retaining clip. You will hear a click when it is properly in place.
- 4** Replace the cover.
- 5** Replace the screws.

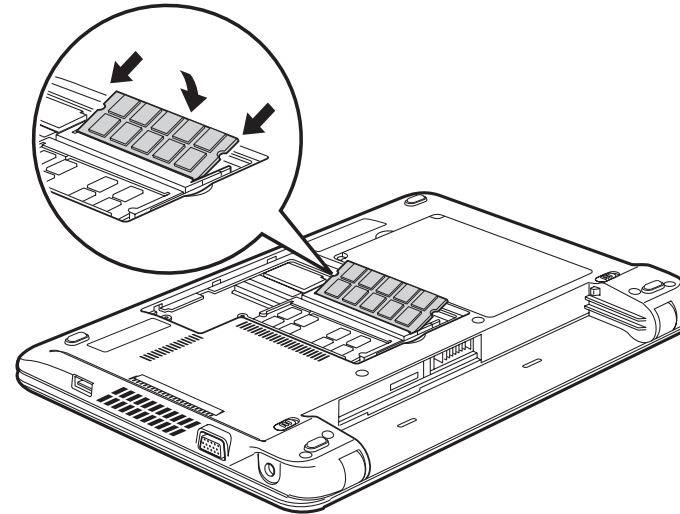

Figure 14. Installing a Memory Module



THE MEMORY UPGRADE MODULE IS NOT SOMETHING YOU ROUTINELY REMOVE FROM YOUR NOTEBOOK. ONCE IT IS INSTALLED, YOU SHOULD LEAVE IT IN PLACE UNLESS YOU WANT TO CHANGE SYSTEM MEMORY CAPACITY.

Checking the Memory Capacity

Once you have changed the system memory capacity by replacing the installed module with a larger one, be sure to check that your notebook has recognized the change.

Check the memory capacity by clicking [Start] > **Control Panel**, then double-clicking the **System** icon. Select the **General** tab and check the amount of memory in the **General** tab.



IF THE TOTAL MEMORY DISPLAYED IS INCORRECT, CHECK THAT YOUR MEMORY UPGRADE MODULE IS PROPERLY INSTALLED. (IF THE MODULE IS PROPERLY INSTALLED AND THE CAPACITY IS STILL NOT CORRECTLY RECOGNIZED, SEE TROUBLESHOOTING ON PAGE 67.

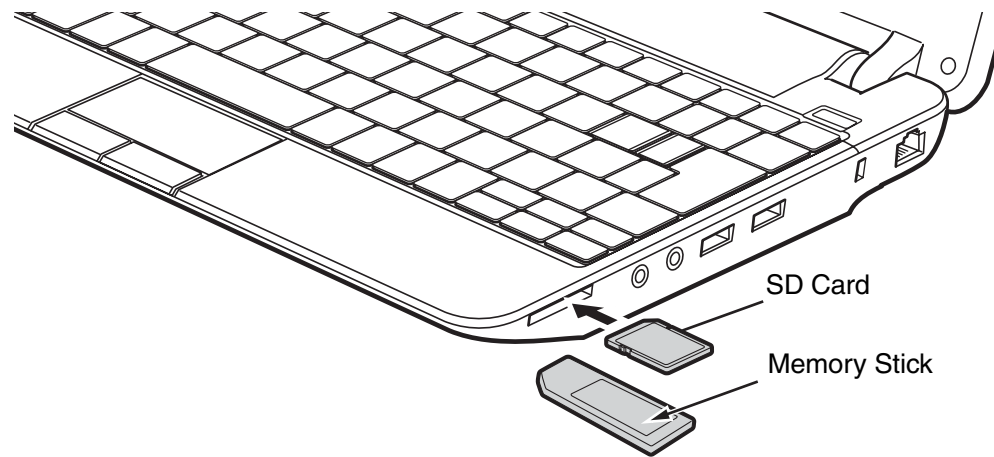

Figure 15. Installing a Memory Stick/SD Card

Memory Stick/Secure Digital Cards

Your notebook supports Memory Stick (MS) and Secure Digital (SD) cards, on which you can store and transfer data to and from a variety of digital devices. These cards use flash memory architecture, which means they don't need a power source to retain data.

Memory Stick and Secure Digital Cards allow portable storage among a variety of devices, such as cell phones, GPS systems, digital cameras, and PDAs. These cards transfer data quickly, with low battery consumption.

Inserting MS/SD Cards

MS and SD Cards are inserted in the MS/SD Card slot (Figure 15). To insert a card, follow these steps:



- INSERTING OR REMOVING AN MS OR SD CARD DURING YOUR NOTEBOOK'S SHUTDOWN OR BOOTUP PROCESS MAY DAMAGE THE CARD AND/OR YOUR NOTEBOOK.
- DO NOT INSERT A CARD INTO A SLOT IF THERE IS WATER OR ANY OTHER SUBSTANCE ON THE CARD AS YOU MAY PERMANENTLY DAMAGE THE CARD, YOUR NOTEBOOK, OR BOTH.

- 1** See your card manual for instructions on the insertion of your card. Some cards may require that your system is off while inserting them.
- 2** Make sure there is no card currently in the slot. If there is, see Removing an SD Card.
- 3** Insert your card into the slot with the product label facing up.
- 4** Push the card firmly into the slot until it is seated in the connector.

Removing an MS/SD Card

To remove a card, first see your card manual for instructions. Some cards may require your notebook to be in Suspend Mode or Off while removing them. Prior to removing the card from the slot, first select it using the Safely Remove Hardware icon in the notification area. To remove the card, push it in to release it, then pull it out.

Device Ports

Your P3010 LifeBook notebook comes equipped with multiple device ports to which you can connect an external device including: disk drives, keyboards, printers, etc.

Internal LAN (RJ-45) jack

The internal LAN (RJ-45) jack is used for an internal 10/100 BaseTx Ethernet connection. You will need to configure your notebook to work with your particular network. (Please refer to your network administrator for information on your network configuration.) To connect the LAN cable follow these easy steps: (*Figure 16*)

- 1 Align the connector with the jack opening.
- 2 Push the connector end into the jack until it is seated.
- 3 Plug the other end into a LAN outlet.

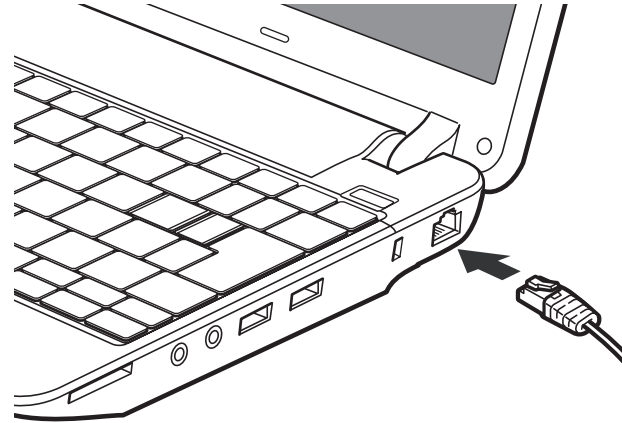

Figure 16. Connecting a LAN plug

Headphone Jack

The headphone jack allows you to connect headphones or powered external speakers to your notebook. Your headphones or speakers must be equipped with a 1/8" (3.5 mm) stereo mini-plug. In order to connect headphones or speakers follow these easy steps: (*See Figure 4 on page 24 for location*)

- 1 Align the connector with the port opening.
- 2 Push the connector into the port until it is seated.



IF YOU PLUG HEADPHONES INTO THE HEADPHONE JACK, THE BUILT-IN STEREO SPEAKERS WILL BE DISABLED.

Microphone Jack

The microphone jack allows you to connect an external mono microphone. Your microphone must be equipped with a 1/8" (3.5 mm) mono mini-plug in order to fit into the microphone jack of your notebook. In order to connect a microphone follow these easy steps: (Figure 4)

- 1 Align the connector with the port opening.
- 2 Push the connector into the port until it is seated.

Universal Serial Bus Ports

The three Universal Serial Bus 2.0 ports (USB) allow you to connect USB devices such as external floppy disk drives, external DVD drives, game pads, pointing devices, keyboards and/or speakers. USB 2.0 is downward-compatible with USB 1.1 devices, so older USB devices will work with these ports. USB 2.0 is a much faster design, running forty times faster than USB 1.1.

In order to connect a USB device, follow these easy steps: (Figure 17)

- 1 Align the connector with the port opening.
- 2 Push the connector into the port until it is seated

External Video Port

The external video port allows you to connect an external monitor or LCD projector. In order to connect an external device follow these easy steps: (Figure 18)

- 1 Align the connector with the port opening.
- 2 Push the connector into the port until it is seated.
- 3 Tighten the two hold-down screws, located on each side of the connector.

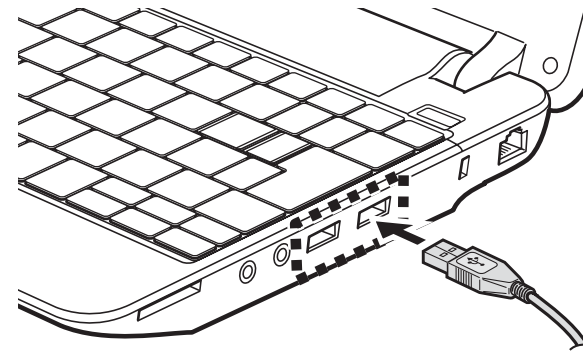

Figure 17. Connecting a USB device



WHEN AN EXTERNAL MONITOR IS PLUGGED IN, PRESSING THE [FN] + [F10] KEYS ALLOWS YOU TO CHANGE YOUR SELECTION OF WHERE TO SEND YOUR DISPLAY

VIDEO. EACH TIME YOU PRESS THE KEY COMBINATION, YOU WILL STEP TO THE NEXT CHOICE, STARTING WITH THE BUILT-IN DISPLAY PANEL ONLY, MOVING TO THE EXTERNAL MONITOR ONLY, FINALLY MOVING TO BOTH THE BUILT-IN DISPLAY PANEL AND AN EXTERNAL MONITOR.

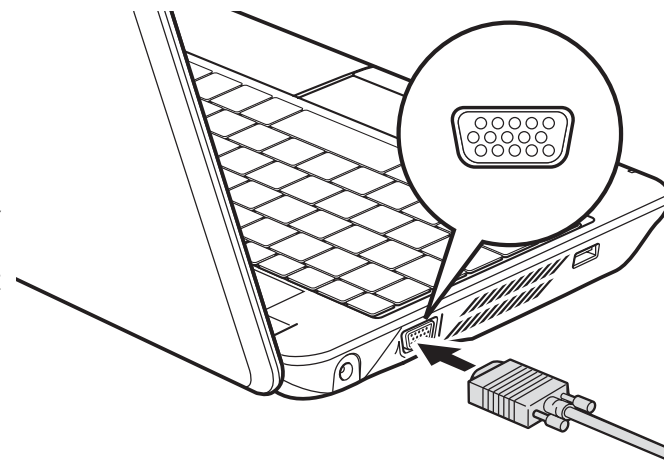

Figure 18. Connecting an external video device



Chapter 4

Troubleshooting Your Notebook

Troubleshooting

There may be occasions when you encounter simple setup or operating problems that you can solve on the spot, or problems with peripheral devices that can be solved by replacing the device. The information in this section helps you isolate and resolve some of these straightforward issues and identify failures that require service.

Identifying the Problem

If you encounter a problem, go through the following procedure before pursuing complex troubleshooting:

- 1 Turn off your notebook.
- 2 Make sure the AC adapter is plugged into your notebook and to an active AC power source.
- 3 Make sure that any devices connected to the external connectors are plugged in properly. You can also disconnect such devices, thus eliminating them as possible causes of failure.
- 4 Turn on your notebook. Make sure it has been off at least 10 seconds before you turn it back on.
- 5 Go through the boot sequence.
- 6 If the problem has not been resolved, refer to the Troubleshooting Table, that follows, for more detailed troubleshooting information.



- IF YOU KEEP NOTES ABOUT WHAT YOU HAVE TRIED, YOUR SUPPORT REPRESENTATIVE MAY BE ABLE TO HELP YOU MORE QUICKLY BY GIVING ADDITIONAL SUGGESTIONS OVER THE PHONE.
- DO NOT RETURN A FAILED NOTEBOOK TO YOUR SUPPLIER UNTIL YOU HAVE TALKED TO A SUPPORT REPRESENTATIVE.

7 If you have tried the solutions suggested in the Troubleshooting Table without success, contact your support representative:

Toll free: 1-800-8Fujitsu (1-800-838-5487)

Web site: <http://www.computers.us.fujitsu.com/support>.

Before you place the call, you should have the following information ready so that the customer support representative can provide you with the fastest possible solution:

- Product name
- Product configuration number
- Product serial number
- Purchase date
- Conditions under which the problem occurred
- Any error messages that have occurred
- Type of device connected, if any

See the Configuration Label on the bottom of your notebook for configuration and serial numbers.

Specific Problems

Using the Troubleshooting Table

When you have problems with your notebook, try to find the symptoms under the Problem column of the troubleshooting table for the feature giving you difficulty. You will find a description of common causes for that symptom under the column Possible Cause and what, if anything, you can do to correct the condition under Possible Solutions. All possible causes or solutions may not apply to your notebook.

Troubleshooting Table

Problem	Page	Problem	Page
Audio Problems	page 70	Power Failures	page 72
Hard Drive Problems	page 70	Shutdown and Startup Problems	page 74
Keyboard or Mouse Problems	page 70	Video Problems	page 75
Memory Problems	page 71	Miscellaneous Problems	page 76
USB Device Problems	page 71		

Problem	Possible Cause	Possible Solutions
Audio Problems		
There is no sound coming from the built-in speakers.	The volume is turned too low.	Adjust the volume control on your notebook and operating system. Use the [Fn+F9] key combination on your keyboard to increase the volume of your notebook.
	The software volume control is set too low.	Manually adjusting the volume (i.e., keyboard "hot keys") should dynamically adjust the volume of the operating system (see above). If that doesn't work, adjust the sound volume control settings in your software or application.
	Headphones are plugged into your notebook.	Plugging in headphones disables the built-in speakers. Remove the headphones.
	The speakers have been muted using the Volume icon in the system tray.	Click the Volume icon in the system tray on the bottom right of the screen. If the Mute box is checked, click on it. You can also press [Fn] + [F3] to toggle the audio on and off.
Hard Drive Problems		
You cannot access your hard drive.	The wrong drive designator was used by an application when a bootable disc was used to start the notebook.	Verify drive designator used by application is in use by the operating system. When the operating system is booted from a CD, drive designations are automatically adjusted.
	Security is set so your operating system cannot be started without a password.	Verify your password and security settings.
Keyboard or Mouse Problems		
The built-in keyboard does not seem to work.	The notebook has gone into Standby mode.	Push the Power/Suspend/Resume button.
	Your application has locked out your keyboard.	Try to use your integrated pointing device to restart your system.
	NumLock key has been set.	Press the NumLock key to toggle it off.

Problem	Possible Cause	Possible Solutions
You have installed an external keyboard or mouse, and it does not seem to work.	Your external device is not properly installed.	Re-install your device. See <i>"Device Ports"</i> on page 64.
	Your operating system (OS) is not set up with correct software driver for that device.	Check your device and operating system documentation and activate the proper driver.
You have connected an external keyboard or a mouse and it seems to be locking up the system.	Your OS is not set up with the correct driver for that device.	Check your device and operating system documentation and activate the proper driver.
	Your system has crashed.	Try to restart your notebook.
Memory Problems		
Your System screen in the Control Panel does not show the correct amount of installed memory.	Your memory upgrade module is not properly installed.	Remove and re-install your memory upgrade module. See <i>"Memory Upgrade Module"</i> on page 58.
	You have a memory failure.	Check for Power On Self Test (POST) messages. See <i>"Power On Self Test Messages"</i> on page 77.
Modem Problems (optional external device)		
Messages about modem operation.	Modem operation messages are generated by whichever modem application is in use.	See your application software documentation for additional information.
USB Device Problems		
You installed a USB device but your notebook does not recognize the device.	The device is not properly installed.	Remove and re-install the device. See <i>"Device Ports"</i> on page 64.
	The device may have been installed while an application was running, so the notebook is not aware of its installation.	Close the application and restart your notebook.
	Your device may not have the correct software driver active.	See your software documentation and activate the correct driver.

Problem	Possible Cause	Possible Solutions
Power Failures		
You turn on your notebook and nothing seems to happen.	The installed battery is completely discharged or there is no Power adapter (AC or Auto/Airline) installed.	Check the Status Indicator Panel to determine the presence and condition of the battery. See "Status Indicator Panel" on page 28. Install a charged battery or a Power adapter.
	The battery is installed but is faulty.	Use the Status Indicator panel to verify the presence and condition of the battery. See "Status Indicator Panel" on page 28. If the battery indicates a malfunction, remove it and operate from another power source or replace that battery.
	The battery is low.	Check the Status Indicator Panel to determine the presence and condition of the battery. See "Status Indicator Panel" on page 28. Use a Power adapter to operate until a battery is charged or install a charged battery.
	The power adapter (AC or auto/airline) is not plugged in properly.	Verify that your adapter is connected correctly. See "Power Sources" on page 42.
	The power adapter (AC or auto/airline) has no power from the AC outlet, airplane jack, or car cigarette lighter.	Move the AC cord to a different outlet, check for a line switch or tripped circuit breaker for the AC outlet. If you are using an auto/airline adapter in a car make sure the ignition switch is in the On or Accessories position.
	The power adapter (AC or auto/airline) is faulty.	Try a different power adapter.
Your notebook turns off all by itself.	The power management parameters are set for auto timeouts which are too short for your operating needs.	Press any button on the keyboard, or move the mouse to restore operation. If that fails, push the Power/Suspend/Resume button. Check your power management settings, or close your applications and go to the Power Options located in the Control Panel to adjust the timeout values to better suit your needs.

Problem	Possible Cause	Possible Solutions
Your notebook turns off all by itself. (continued)	You are operating on battery power and ignored a low battery alarm until the battery was at the dead battery state and the system has entered Dead Battery Suspend mode.	Install a power adapter, then push the Power/Suspend/Resume button. <i>See "Power Sources" on page 42.</i>
	You have a battery failure.	Verify the condition of the battery using the Status Indicator panel. If the battery is shorted, replace or remove it. <i>See "Status Indicator Panel" on page 28.</i>
	Your power adapter has failed or lost its power source.	Make sure the adapter is plugged in and the outlet has power.
Your notebook will not work on battery alone.	The installed battery is dead.	Replace the battery with a charged one or install a power adapter.
	No battery is installed.	Install a charged battery.
	The battery is improperly installed.	Verify that the battery is properly connected by re-installing it.
	Your installed battery is faulty.	Verify the condition of the battery using the Status Indicator panel and replace or remove any batteries that are shorted. <i>See "Status Indicator Panel" on page 28.</i>
The battery seems to discharge too quickly.	The power savings features may be disabled.	Check the Power Options menu settings and adjust according to your operating needs.
	You are running an application that uses a lot of power due to frequent hard drive access or optical drive access, or use of a Wireless LAN or other device.	Use a power adapter for this application when at all possible.
	The battery is very old.	Replace the battery.

Problem	Possible Cause	Possible Solutions
The battery seems to discharge too quickly. (continued)	The brightness is turned all the way up.	Turn down the brightness adjustment. The higher the brightness the more power your display uses.
	Battery has been exposed to high temperatures.	Replace the battery.
	The battery is too hot or too cold.	Restore the notebook to normal operating temperature. Charging icon on the Status Indicator panel will flash when battery is outside of operating range.
Shutdown and Startup Problems		
The Suspend/Resume button does not work.	Suspend/Resume button is disabled.	Enable the button by going to the Control Panel > Power Options Properties and clicking on the Advanced tab. In the Power buttons area, select the option that suits your needs.
	There may be application software conflict.	Close all applications and try the button again.
The system powers up, and displays power on information, but fails to load the operating system.	The boot sequence settings of the setup utility are not compatible with your configuration.	Set the operating source by pressing the [ESC] key while the Fujitsu logo is on screen or use the [F2] key and enter the setup utility and adjust the source settings from the Boot menu. <i>See "BIOS Setup Utility" on page 44.</i>
	You have a secured system requiring a password to load your operating system.	Make sure you have the right password. Enter the setup utility and verify the Security settings and modify them as accordingly. <i>See "BIOS Setup Utility" on page 44.</i>
An error message is displayed on the screen during the boot sequence.	Power On Self Test (POST) has detected a problem.	See the Power On Self Test (POST) messages to determine the meaning and severity of the problem. Not all messages are errors; some are simply status indicators. <i>See "Power On Self Test Messages" on page 77.</i>
Your notebook appears to change setup parameters when you start it.	BIOS setup changes were not saved when made and you exited the setup utility.	Make sure you select Save Changes And Exit when exiting the BIOS setup utility.

Problem	Possible Cause	Possible Solutions
<p>Your notebook appears to change setup parameters when you start it..</p> <p>(continued)</p>	The BIOS CMOS hold-up battery has failed.	Contact your support representative for repairs. This is not a user serviceable part but has a normal life of 3 to 5 years.
Video Problems		
The built-in display is blank when you turn on your notebook.	An external monitor is plugged in, and the system is set for an external monitor only.	Pressing [F10] while holding down [Fn] allows you to change where to send your display video. Each time you press the combination of keys you will step to the next choice. The choices, in order are: built-in display, external monitor, both built-in display and external monitor.
	Display angle and brightness settings are not adequate for your lighting conditions.	Move the display and the brightness control until you have adequate visibility. Pressing either the [F6] or [F7] keys while holding down the [Fn] key also allows you to change the brightness level of the display.
	Power management timeouts are set for short intervals and you didn't see the display go on and off again.	Press a keyboard button or move the mouse to restore operation. If that fails, push the Power/Suspend/Resume button. (The display may be shut off by Standby mode, Auto Suspend or Video Timeout)
The notebook turned on with a series of beeps and the built-in display is blank.	Power On Self Test (POST) detected a failure which does not allow display to operate.	Contact your support representative.
The display goes blank by itself after you have been using it.	The notebook has gone into Video timeout, Standby mode, or Save-to-Disk mode because you have not used it for a period of time.	Press any button on the keyboard, or move the mouse to restore operation. If that fails, push the Power/Suspend/Resume button. Check power management settings, or close your applications and go to the Power Savings menu of the setup utility to adjust the timeout values to better suit your operation needs. See "BIOS Setup Utility" on page 44.
The display does not close.	Foreign object stuck between display and keyboard.	Remove all foreign objects, such as a paperclip, from the keyboard.

Problem	Possible Cause	Possible Solutions
The display goes blank by itself after you have been using it. (continued)	Power timeouts are set for very short intervals and you failed to notice the display come on and go off again.	Press any button on the keyboard, or move the mouse to restore operation. If that fails, push the Power/Suspend/Resume button. (The display may be shut off by Standby Mode, Auto Suspend or Video Timeout)
The display has bright or dark spots.	If the spots are very tiny and few in number, this is normal for a large LCD display.	This is normal; do nothing.
	If the spots are numerous or large enough to interfere with your operation needs.	Display is faulty; contact your support representative.
The application display uses only a portion of your screen and is surrounded by a dark frame.	You are running an application that does not support the system's native resolution and display compression is enabled.	Display compression gives a clearer but smaller display for applications that do not support the system's native pixel resolution. You can fill the screen but have less resolution by changing display compression settings. These settings can be changed in the Intel GMA control panel.
You connected an external monitor and it does not display any information.	Your external monitor is not properly installed.	Reinstall your device. See <i>"External Video Port"</i> on page 65.
	Your operating system is not setup with the correct software driver for that device.	Check your device and operating system documentation and activate the proper driver.
You have connected an external monitor and it does not come on.	Your external monitor is not compatible with your notebook.	See your monitor documentation and the External Monitor Support portions of the Specifications section. See "Specifications" on page 91.
Miscellaneous Problems		
Error message displayed on the screen during operation of an application.	Application software often has its own set of error message displays.	See your application manual and help displays screens for more information. Not all messages are errors some may simply be status.

Power On Self Test Messages

The following is an alphabetic list of error-and-status messages that Phoenix BIOS and/or your operating system can generate and an explanation of each message. Error messages are marked with an *. If an error message is displayed that is not in this list, write it down and check your operating system documentation both on screen and in the manual. If you can find no reference to the message and its meaning is not clear, contact your support representative for assistance.

Check date and time settings

Verify that the date and time settings are correct.

***Extended Memory Failed at address line: nn**

Extended memory not working or not configured properly. If you have an installed memory upgrade module, verify that the module is properly installed. If it is properly installed, you may want to check your Windows Setup to be sure it is not using unavailable memory until you can contact your support representative.

***Failure Fixed Disk n**

The fixed disk is not working or not configured properly. This may mean that the hard drive type identified in your setup utility does not agree with the type detected by the Power On Self Test. Run the setup utility to check for the hard drive type settings and correct them if necessary. If the settings are OK and the message appears when you restart the system, there may be a serious fault which might cause you to lose data if you continue. Contact your support representative.

Fan error has occurred

POST has determined that there is an error with the system fan. Contact your support representative.

***Invalid system disk**

Problem with the system disk. Replace the disk and then press any key to continue.

***Keyboard error**

Keyboard not working. You may have to replace your keyboard or keyboard controller but may be able to use an external keyboard until then. Contact your support representative.

Non-system disk or disk error

Replace the disk and then press any key to continue.

NTLDR is missing

Press any key to restart.

***Operating system not found**

Operating system cannot be located on either drive A: or drive C: Enter the setup utility and see if both the fixed disk, and drive A: are properly identified and that the boot sequence is set correctly. Unless you have changed your installation greatly, the operating system should be on drive C:. If the setup utility is correctly set, your hard drive may be corrupted.

***Press <F1> to resume, <F2> to SETUP**

Displayed after any recoverable error message. Press the [F1] key to continue the boot process or the [F2] key to enter Setup and change any settings.

PXE-E32: TFTP open timeout

Contact your support representative for more information.

PXE-E53: No boot filename received

Contact your support representative for more information.

PXE-E61: Media test failure, check cable

Check the system cables. If that does not correct the failure, contact your support representative for more information.

PXE-E78: Could not locate boot server

Contact your support representative for more information.

PXE-E89: Could not download boot image

Contact your support representative for more information.

***Real time clock error**

Real-time clock fails BIOS test. May require board repair. Contact your support representative.

Remove disks or other media

Remove disks or other media, then press any key to restart.

***Stuck key**

BIOS discovered a stuck key. You may have to replace your keyboard but may be able to use an external keyboard until then. Contact your support representative.

***System CMOS checksum bad – Default configuration used**

BIOS CMOS RAM has been corrupted or modified incorrectly, perhaps by an application program that changes data stored in BIOS memory. Run Setup and reconfigure the system.

***System timer error**

The timer test failed. The main clock that operates the computer is faulty. Requires repair of system board. Contact your support representative for repairs.

Thermal sensor error has occurred

The thermal sensor has either failed or is out of thermal range.

Restoring Your System Image and Software

Packed with your system you will find two discs for recovering your pre-installed software:

- Drivers and Applications Restore Disc
- Recovery and Utility Disc

Drivers and Applications Restore Disc

The Drivers and Applications Restore (DAR) disc included with your system contains sets of device drivers and Fujitsu utilities (in specific directories) that are unique to your computer configuration.



IF YOU HAVE ACCESS TO THE INTERNET, VISIT THE FUJITSU SUPPORT WEBSITE AT [HTTP://WWW.COMPUTERS.US.FUJITSU.COM/SUPPORT](http://www.computers.us.fujitsu.com/support) TO CHECK FOR THE MOST CURRENT INFORMATION, DRIVERS AND HINTS ON HOW TO PERFORM RECOVERY AND SYSTEM UPDATES.

Re-installing Individual Drivers and Applications

The Drivers and Applications disc can be used to selectively re-install drivers and/or applications that may have been un-installed or corrupted.



THERE MAY BE CERTAIN FREE THIRD-PARTY APPLICATIONS PRE-INSTALLED ON YOUR SYSTEM THAT ARE NOT ON THE DAR DISC. THE LATEST VERSIONS OF THE APPLICATIONS CAN BE DOWNLOADED FROM THE THIRD-PARTY'S WEBSITE.

To re-install drivers and/or applications:

- 1** Boot up the system and insert the DAR disc after Windows has started. A Fujitsu Installer screen is displayed after the disc is inserted.
- 2** After reading the License Agreement, click [I agree].
- 3** A window will appear containing a list of applications, drivers, and utilities that you can install from the DAR disc.

- 4 In the list, check off all the components you want to install. If you want to install all components, click [Select All]. Clicking [Select All] will select all of the blue-coded components; you must select grey and green components separately.
- 5 Once you have selected the components you wish to install, click [Install Selected Subsystems]; the components will be installed.
- 6 After the components are installed, click [OK], then click [Yes] when asked if you want to reboot the system.

Recovery and Utility Disc

The Recovery and Utility disc contains four utilities:

- The **Recovery** utility allows you to restore the system operating system (OS). The restored OS is the same one that was originally installed on the hard disk drive. After the OS is restored, you will need to reinstall the drivers and applications from the Drivers and Applications Restore disc and from any application discs that were bundled with the system when you purchased it.
- The **Hard Disk Data Delete** utility on this disc is used to delete all data on your hard disk and prevent it from being reused. Do not use the Hard Disk Data Delete utility unless you are absolutely certain that you want to erase your entire hard disk, including all partitions.
- The **Partition Creation** utility allows you to create a new D: partition or resize existing partitions on your hard disk. **NOTE: Creating or resizing partitions with this utility will cause all data on the hard disk to be completely erased.**
- The **Diagnostics** utility allows the IT professional to determine device status/condition by executing diagnostics tests on selected system components.

To use the disc, follow the instructions in the “Using the Recovery and Utility Disc” booklet that is packaged with the disc.

Automatically Downloading Driver Updates

Your system has a convenient tool called the Fujitsu Driver Update (FDU) utility. With FDU, you can choose to automatically or manually go to the Fujitsu site to check for new updates for your system.

The FDU icon should appear in the system tray at the bottom right of your screen (roll the cursor over the icons to find the correct one). If the icon does not appear in the system tray, go to [Start] -> All Programs, and click on Fujitsu Driver Update; this will create the icon automatically.

To invoke the FDU menu, right-click on the FDU icon. The menu contains the following items:

Check for updates now

Allows for manual driver update search. The first time it is used, you are prompted to agree to a user agreement. After clicking on the icon, the FDU automatically connects with the Fujitsu site to check for updates and downloads them. While downloading, the icon has a red bar through it, indicating that it cannot be used while the download is in process. When the update is complete, a message appears informing you of the fact.

Enable Automatic Update Notifications

Automatically searches for new updates on a regular basis (approximately every 3 days).

Show update history

Brings up a screen that displays a history of updates that have been made via the FDU.

About Fujitsu Driver Update

Displays the FDU version number and copyright information.

Fujitsu Driver Update Readme

Displays the FDU readme.

Chapter 5

Care and Maintenance

Caring for your P3010 LifeBook

If you use your Fujitsu notebook carefully, you will increase its life and reliability. This section provides some tips for looking after the notebook and its devices.



- IN THE EVENT YOU DROP YOUR NOTEBOOK OR DAMAGE THE HOUSING IN ANY WAY, IMMEDIATELY TURN OFF POWER AND DISCONNECT THE POWER PLUG. FAILURE TO DO SO COULD RESULT IN A SHORT CIRCUIT, SMOKE, AND/OR FIRE. CONTACT FUJITSU SERVICE AND SUPPORT BY PHONE AT 1-800-8FUJITSU (1-800-838-5487), BY EMAIL AT 8FUJITSU@US.FUJITSU.COM, OR THROUGH THE WEBSITE AT [HTTP://WWW.COMPUTERS.US.FUJITSU.COM/SUPPORT](http://www.computers.us.fujitsu.com/support) TO LEARN HOW TO GET THE SYSTEM REPAIRED.
- THE SYSTEM CONTAINS COMPONENTS THAT CAN BE SEVERELY DAMAGED BY ELECTROSTATIC DISCHARGE (ESD). TO MINIMIZE RISK TO THE COMPONENTS, OBSERVE THE FOLLOWING PRECAUTIONS:
 - BEFORE DOCKING OR UNDOCKING YOUR NOTEBOOK (WHEN USING A PORT REPLICATOR), IT IS A GOOD IDEA TO ALWAYS TOUCH A GROUNDED METAL OBJECT TO DISCHARGE STATIC ELECTRICITY BUILT UP IN YOUR BODY.
 - BE SURE TO POWER DOWN YOUR SYSTEM BEFORE ADDING OR REMOVING SYSTEM COMPONENTS. EVEN IF THE SYSTEM IS IN HIBERNATE OR SLEEP STATES, DATA COULD BE LOST OR MEMORY COULD BE DAMAGED IF POWER IS STILL AVAILABLE TO THE SYSTEM.
 - WHEN INSTALLING OR REMOVING A MEMORY MODULE, HOLD IT BY THE EDGE SO AS NOT TO TOUCH ANY CONTACTS OR CHIPS. BE CAREFUL NOT TO TOUCH ANY INTERNAL COMPUTER TERMINALS OR COMPONENTS; THE OIL FROM YOUR FINGERS COULD CAUSE A SHORT TO THE COMPONENTS.
- ELECTRICAL EQUIPMENT MAY BE HAZARDOUS IF MISUSED. OPERATIONS OF THIS PRODUCT OR SIMILAR PRODUCTS, MUST ALWAYS BE SUPERVISED BY AN ADULT. DO NOT ALLOW CHILDREN ACCESS TO THE INTERIOR OF ANY ELECTRICAL PRODUCTS AND DO NOT PERMIT THEM TO HANDLE ANY CABLES.

- Your notebook is a durable but sensitive electronic device. Treat it with respect and care.
- Make a habit of transporting it in a suitable carrying case.
- Do not attempt to service the computer yourself. Always follow installation instructions closely.
- Keep it away from food and beverages.
- To protect your notebook from damage and to optimize system performance, be sure to **keep all air vents unobstructed, clean, and clear of debris**. This may require periodic cleaning, depending upon the environment in which the system is used.
- Do not operate the notebook in areas where the air vents can be obstructed, such as in tight enclosures or on soft surfaces like a bed or cushion.
- If you accidentally spill liquid on your notebook:
 - 1 Turn it off.
 - 2 Position it so that the liquid can run out.
 - 3 Let it dry out for 24 hours, or longer if needed.
 - 4 If your notebook will not boot after it has dried out, call your support representative.
- Do not use your Fujitsu notebook in a wet environment (near a bathtub, swimming pool).
- Always use the AC adapter and batteries that are approved for your notebook.
- Avoid exposure to sand, dust and other environmental hazards.
- Do not expose your notebook to direct sunlight for long periods of time as temperatures above 140° F (60° C) may damage your notebook.
- Do not put heavy or sharp objects on the computer.
- If you are carrying your notebook in a briefcase, or any other carrying case, make sure that there are no objects in the case pressing on the lid.
- Never position your notebook such that the optical drive is supporting the weight of the notebook.

Cleaning your notebook

- Always disconnect the power plug. (Pull the plug, not the cord.)
- Clean your notebook with a damp, lint-free cloth. Do not use abrasives or solvents.
- Use a soft cloth to remove dust from the screen. Never use glass cleaners.
- Always shut down the computer, unplug the power adapter, and remove the battery when cleaning or disinfecting the computer exterior, keyboard or LCD display.

Cleaning guidelines using recommended off-the-shelf cleaners

Computer exterior, computer keyboard

To clean the exterior and keyboard, use one of the following off-the-shelf products:

- Office Depot® #154-616 Notebook Cleaning Kit
- Meridrew Enterprises Klear_Screen® Wipes
- 3M CL563 Cleaner Wipes

Note: After cleaning with one of these products, gently polish with a dry, soft, lint-free cloth until the solution is no longer visible.

LCD display

To clean the LCD display, use one of the following off-the-shelf products:

- Office Depot® #154-616 Notebook Cleaning Kit
- Meridrew Enterprises Klear_Screen® Wipes

* Applies to Tablet PC, convertible PC with LCD shield, and standard notebook LCD displays.

Wipe the LCD surface gently, allowing it to dry before turning on the computer.

Disinfecting notebook computers

Wipe the surface with a soft cloth wipe and a 50% ethanol solution or use another ethanol-based germicide which has been registered as a hospital disinfectant by the EPA.



- USE OF INCORRECT CLEANERS CAN RESULT IN OPTICAL IMPAIRMENT OF THE LCD AND/OR DAMAGE TO THE COMPUTER. ALWAYS REFER TO THE CLEANER MANUFACTURER'S GUIDELINES AND MATERIAL SAFETY DATA SHEETS FOR PROPER HANDLING AND USE OF THE PRODUCTS.
- NEVER USE AMMONIA, ACIDIC, OR ALKALINE CLEANERS OR ORGANIC CHEMICALS SUCH AS PAINT THINNER, ACETONE, PROPYL OR ISOPROPYL ALCOHOL, OR KEROSENE. IT MAY DAMAGE SURFACE FINISHES AND THE COATING OF THE LCD SCREEN.
- NEVER USE COMPRESSED AIR FOR CLEANING YOUR NOTEBOOK.

Cleaning the dust filter

Your LifeBook is equipped with fans to make air flow inside by pulling in outside air to cool the inside of the system. Depending on the environment in which the system is used, dust and dirt may be pulled in along with the air. Accumulated dust and dirt could impair the function of the system.



- **REMOVE AC ADAPTER:** BEFORE CLEANING THE FILTER, TURN OFF THE SYSTEM AND PERIPHERALS AND DISCONNECT THE AC ADAPTER.
- **CLEANING THE FILTER:**
 - DO NOT USE DETERGENT
 - AVOID DAMAGING THE FILTER; DAMAGE TO THE FILTER IS NOT COVERED BY WARRANTY.
 - USE A VACUUM CLEANER HANDHELD ATTACHMENT TO CLEAN THE FILTER. METAL OR WOODEN TOOLS COULD DAMAGE THE FILTER.
- **ESD:** BEFORE CLEANING THE FILTER, TOUCH A METAL OBJECT TO DISCHARGE STATIC ELECTRICITY.

- 1 Turn off your computer and disconnect the AC adapter.
- 2 Close the display panel and turn the system upside down.
- 3 Remove the dust filter access cover by pressing the latch toward the center of the cover and lifting it out (Fig.19).
- 4 Carefully clean the embedded dust filter and the air-cooling duct using a vacuum cleaner attachment (such as an extension wand).

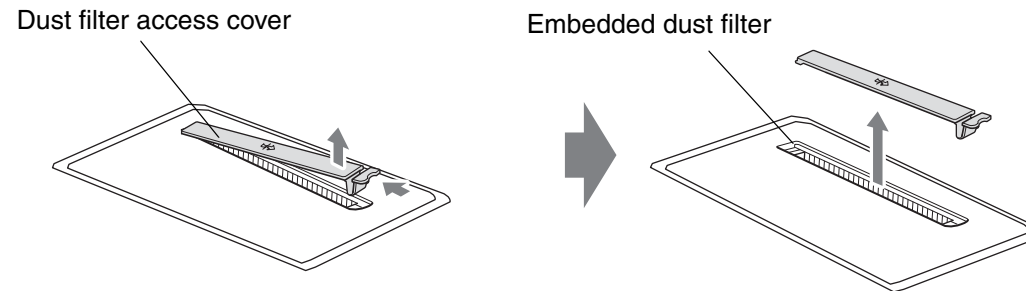

Figure 19. Removing/installing the dust filter access cover

- 5 Put back the dust filter access cover by inserting the end without latch first (positioning the key inside first), and pushing in the cover until it latches.



ALWAYS BE SURE THE DUST FILTER ACCESS COVER IS INSTALLED WHEN RUNNING YOUR SYSTEM. NOT USING THE FILTER COVER COULD CAUSE CONTAMINATION AND POSSIBLE DAMAGE TO THE SYSTEM.

Storing your notebook





- If storing your notebook for a month or longer, turn your notebook off, fully charge the battery, then remove and store all Lithium ion batteries.
- Store your notebook and batteries separately. If you store your notebook with a battery installed, the battery will discharge, and battery life will be reduced. In addition, a faulty battery might damage your notebook.
- Store your Fujitsu notebook in a cool, dry location. Temperatures should remain between 13°F (-25°C) and 140°F (60°C).



- ALWAYS POWER OFF THE COMPUTER BEFORE TRANSPORTING AND/OR PACKAGING IT. AFTER SHUTTING DOWN THE SYSTEM, WAIT UNTIL THE STATUS LED PANEL INDICATES POWER OFF CONDITION (NO LIGHTS ARE ILLUMINATED).
- IT IS POSSIBLE THAT THE UNIT MAY NOT AUTOMATICALLY GO TO POWER OFF OR HIBERNATE MODE WHEN YOU CLOSE THE LID. THIS SITUATION MAY OCCUR DUE TO PRE-OS BOOT PASSWORD SECURITY SETTINGS OR SOME OTHER APPLICATION RUNNING ON THE COMPUTER.
- ATTEMPTING TO TRANSPORT THE COMPUTER WHILE POWER IS ON MAY DAMAGE THE NOTEBOOK DUE TO SHOCK OR OVERHEATING SINCE THE AIR VENTS MAY BE BLOCKED OR RESTRICTED.

Traveling with your notebook

- Do not transport your notebook while it is turned on.
- It is recommended that you carry your notebook with you while traveling, rather than checking it in as baggage.
- Always bring your System Recovery CD that came with your notebook when you travel. If you experience system software problems while traveling, you may need it to correct any problems.
- Take the necessary plug adapters if you're traveling overseas. Check the following diagram to determine which plug adapter you'll need or ask your travel agent.

Outlet Type	Location	Outlet Type	Location
 	United States, Canada, parts of Latin America, Mexico, Japan, Korea, the Philippines, Taiwan		Russia and the Commonwealth of Independent States (CIS), most of Europe, parts of Latin America, the Middle East, parts of Africa, Hong Kong, India, most of South Asia
	United Kingdom, Ireland, Malaysia, Singapore, parts of Africa		China, Australia, New Zealand

- Never put your notebook through a metal detector. Have your notebook hand-inspected by security personnel. You can however, put your notebook through a properly tuned X-ray machine. To avoid problems, place the notebook close to the entrance of the machine and remove it as soon as possible or have it hand-inspected by security personnel. Security officials may require you to turn your notebook on, so make sure you have a charged battery on hand.

Batteries

Caring for your Batteries

- Always handle batteries carefully.
- Do not short-circuit the battery terminals (that is, do not touch both terminals with a metal object). Do not carry loose batteries in a pocket or purse where they may mix with coins, keys, or other metal objects. Doing so may cause an explosion or fire.
- Do not drop, puncture, disassemble, mutilate or incinerate the battery.
- Recharge batteries only as described in this manual and only in ventilated areas.
- Do not leave batteries in hot locations for more than a day or two; high heat can shorten battery life.
- Do not leave a battery in storage for longer than 6 months without recharging it.

Increasing Battery Life

- Power your notebook through the AC or optional auto/airline adapter whenever possible.
- If your notebook is running on battery power all day, connect it to the AC adapter overnight to recharge the battery.
- Keep brightness to the lowest level comfortable.
- Set the power management for maximum battery life.
- Put your notebook in standby mode when it is turned on and you are not actually using it.
- Limit your media drive access.
- Disable the Media Player auto insert notification function.
- Always use fully charged batteries.

Media Care

Caring for your Media (optional)

Media discs (DVD/CD/CD-R) are precision devices and will function reliably if given reasonable care.

- Always store your media disc in its case when it is not in use.
- Always handle discs by the edges and avoid touching the surface.
- Avoid storing any media discs in extreme temperatures.
- Do not bend media discs or set heavy objects on them.
- Do not spill liquids on media discs.
- Do not scratch or get dust on media discs.
- Never write on the label surface with a ballpoint pen or pencil. Always use a felt pen.
- If a media disc is subjected to a sudden change in temperature, cold to warm condensation may form on the surface. Wipe the moisture off with a clean, soft, lint free cloth and let it dry at room temperature. DO NOT use a hair dryer or heater to dry media discs.
- If a disc is dirty, use only a DVD/CD cleaner or wipe it with a clean, soft, lint free cloth starting from the inner edge and wiping to the outer edge.

Caring for your Optical Drive (optional)

The optional external optical drive is durable but you must treat it with care. Pay attention to the following:

- The drive rotates the compact disc at a very high speed. Do not carry it around or subject it to shock or vibration with the power on.
- Avoid using or storing the drive where it is damp, dusty, or will be exposed to extreme temperatures.
- Avoid using or storing the drive near magnets or devices that generate strong magnetic fields.
- Avoid using or storing the drive where it will be subjected to shock or vibration.
- Do not disassemble or dismantle the optical drive.
- Use of a commercially available lens cleaner is recommended for regular maintenance of the drive.

Chapter 6

System Specifications

Specifications

This section provides the hardware and environmental specifications for your Fujitsu P3010 LifeBook notebook. Specifications of particular configurations will vary.

Configuration Label

The configuration label located on the bottom of your notebook contains specific information regarding the options you've chosen for your notebook. Following is an example configuration label.

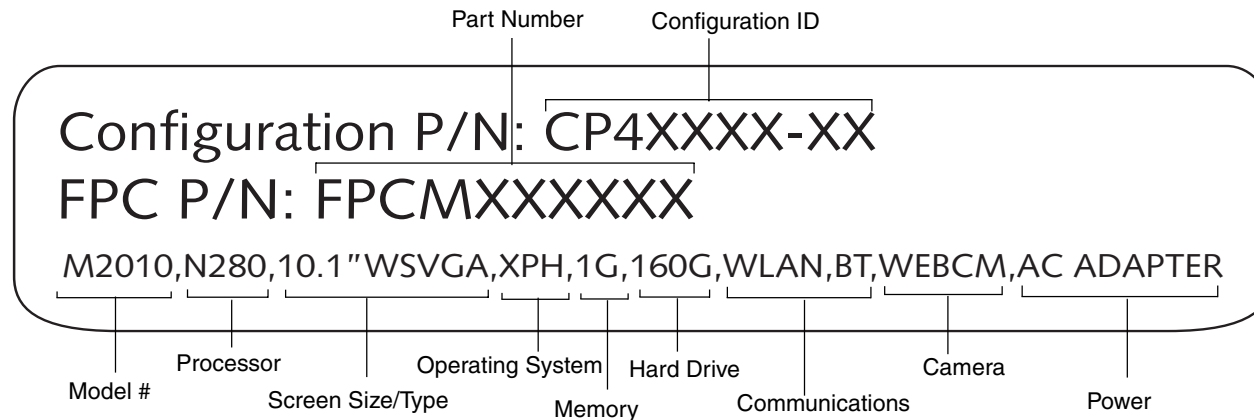

Microprocessor

MD Athlon™ Neo MV-40 processor

Chipset

- AMD RS780MN
- [I/O Controller Hub 7 Mobile \(ICH7M\)](#)

Memory

System Memory

- DDR2-800 MHz SDRAM memory module.
- Two DIMM slots; upgradeable.

Cache Memory

512 KB L2 cache on-die

Video

Built-in color flat-panel TFT active matrix LED backlight display with simultaneous display capability.

Video Color and Resolution

11.6" Wide SVGA display

- Internal: 1366 x 768 pixel resolution (16:9), 16M colors
- External: 1600 x 1200 pixel resolution, 16M colors
- Simultaneous: 1600 x 1200 pixel resolution, 16M colors

[AMD RS780 video graphics. Up to 128 MB shared video memory using Dynamic Video Memory Technology \(DVMT\)](#)

Audio

- Realtek codec ALC269Q-GR with High Definition (HD) audio.
- **Headphones:** Stereo headphone jack, 3.5 mm, 1 V_{rms} or less, minimum impedance 32 Ohms
- **Microphone:** Stereo microphone jack, 3.5 mm, 100 mV_{p-p} or less, minimum impedance 10K Ohms
- Two built-in stereo speakers
- One built-in digital mono microphone

Mass Storage Device Options

Hard Drive

Serial ATA, 150 Mbps data buffer, 5400 rpm, 2.5”

Features

Integrated Pointing Device

Touchpad cursor control

Web Camera

Integrated 1.3 MP web camera

Communications

- **Gigabit LAN:** Internal wired 10/100 Ethernet LAN
- **WLAN:** Atheros Align™ 802.11bgn
- **Bluetooth:** Bluetooth V2.1 device for wireless personal area network communication
- Wireless LAN antenna

Theft Prevention Lock

Lock slot for use with security restraint systems.

Device Ports

On the notebook:

- Memory Stick/Secure Digital (MS/SD) Card slot
- One 15-pin D-SUB connector for VGA external monitor (see Display specifications)
- Three USB 2.0 (Universal Serial Bus) connectors for input/output devices
- One DC In connector
- One LAN (RJ-45) connector
- One stereo headphone jack
- One stereo microphone/line-in jack

Keyboard

Built-in keyboard with all functions of 101 key PS/2 compatible keyboards.

- Total number of keys: 84
- Function keys: F1 through F12, plus Fn extension key
- Two Windows keys: one Start key, one application key
- Key pitch: 19 mm; key stroke: 1.8 mm
- Left and right buttons
- External USB keyboard/mouse support

Power

Battery

Standard Lithium ion battery, rechargeable, 6-cell 10.8V, 5200 mAh

AC Adapter

Autosensing 100-240V AC, supplying 19V DC, 3.16A (60W), to the notebook; includes an AC cable

Power Management

Conforms to ACPI (Advanced Configuration and Power Interface).

Dimensions and Weight

Overall Dimensions

Approximately 10.16"(w) x 7.4"(d) x 1.26" / 1.69" (h) (258 mm x 188 mm x 32 mm / 42.9 mm)

Weight

Approximately 2.93 lb. (1.33 Kg) with battery

Environmental Requirements

Temperature

Operating: 41° to 95° F (5° to 35° C). Non-operating: 5° to 140° F (-15° to 60° C)

Humidity

Operating: 20% to 85%, relative, non-condensing. Non-operating: 8% to 85%, relative, non-condensing

Altitude

Operating: 10,000 feet (3,048 m) maximum

Popular Accessories

For ordering or additional information on Fujitsu accessories please visit our Web site at www.shopfujitsu.com or call 1-800-FUJITSU.

Included Software

Depending on your operating system, your notebook comes with software for playing audio and video files of various formats. In addition there is file transfer software, virus protection software and Power Management software. The following list indicates the software included with your system.

- Adobe Reader
- CyberLink PowerDVD
- CyberLink YouCam
- Norton Internet Security™ (90-day free trial)
- Roxio Creator
- Fujitsu Driver Update Utility
- Microsoft Office Activation Assistant
- Microsoft Works 9.0 with Office 2007 Student and Home Trial Edition

Learning About Your Software

Tutorials

All operating systems and most application software have tutorials built into them upon installation. We highly recommend that you step through the tutorial before you use an application.

Manuals

Included with your notebook you will find manuals for your installed operating system and other pre-installed software. Any manuals that are not included, are available online through the help system of the software. We recommend that you review these manuals for general information on the use of these applications.

Adobe Reader

The Adobe Reader allows you to view, navigate, and print PDF files from across all of the major computing platforms.

Norton Internet Security

Your system is preinstalled with a free 60-day trial version of Symantec's Norton Internet Security™. Norton Internet Security is a suite of tools designed to protect your notebook from computer viruses, hackers, spyware, and spam. It assists in the protection of data currently on your hard disk from destruction or contamination. The trial version is activated upon your acceptance of software license agreement. After 60 days, you will need to purchase a subscription from Symantec to download latest virus, spyware, and spam definitions.

Roxio Creator

Roxio Creator lets you burn CDs and organize, edit and share digital photos, music, data, or videos.

CyberLink PowerDVD

CyberLink PowerDVD allows you to produce and edit home movies and slideshows on discs.

CyberLink YouCam

CyberLink YouCam allows you to capture photos or movies on the embedded webcam, add special effects to them, and share them in a variety of formats or via social networks.

Fujitsu Driver Update Utility

The Fujitsu Driver Update (FDU) utility is pre-installed on your system. With FDU, you can choose to automatically or manually go to the Fujitsu site to check for new updates for your system. See "Automatically Downloading Driver Updates" on page 82.

Microsoft Works with Office 2007 Student and Home Trial Edition

Microsoft Works 9.0 is a software suite containing the basic tools to write letters and reports, track family and friends with address books, manage home finances, and create a home inventory.



Glossary



AC Adapter

A device which converts the AC voltage from a wall outlet to the DC voltage needed to power your notebook.

Access point

Wireless network device used to bridge wireless and wired network traffic.

ACPI

Advanced Configuration and Power Interface

Active-Matrix Display

A type of technology for making flat-panel displays which has a transistor or similar device for every pixel on the screen.

Ad Hoc Mode

Ad Hoc Mode refers to a wireless network architecture where wireless network connectivity between multiple computers is established without a central wireless network device, typically known as Access Points. Connectivity is accomplished using only client devices in a peer-to-peer fashion.

ADSL

Asymmetric Digital Subscriber Line. Technology for transporting high bit-rate services over ordinary phone lines.

AGP

Accelerated Graphics Port. Graphics port specifically designed for graphics-intensive devices, such as video cards and 3D accelerators.

Auto/Airline Adapter

A device which converts the DC voltage from an automobile cigarette lighter or aircraft DC power outlet to the DC voltage needed to power your notebook.

BIOS

Basic Input-Output System. A program and set of default parameters stored in ROM which tests and operates your notebook when you turn it on until it loads your installed operating system from disk. Information from the BIOS is transferred to the installed operating system to provide it with information on the configuration and status of the hardware.

Bit

An abbreviation for binary digit. A single piece of information which is either a one (1) or a zero (0).

bps

An abbreviation for bits per second. Used to describe data transfer rates.

Boot

To start-up a computer and load its operating system from disk, ROM or other storage media into RAM.

Bus

An electrical circuit which passes data between the CPU and the sub-assemblies inside your notebook.

Byte

8 bits of parallel binary information.

Cache Memory

A block of memory built into the micro-processor which is much faster to access than your system RAM and used in specially structured ways to make your overall data handling time faster.

CD-ROM

Compact disk read only memory. This is a form of digital data storage which is read optically with a laser rather than a magnetic head. A typical CD-ROM can contain about 600MB of data and is not subject to heads crashing into the surface and destroying the data when there is a failure nor to wear from reading.

Channel

Range of narrow-band frequencies used by the WLAN device to transmit data. IEEE802.11b/g - 11 channels, 22 MHz wide channels.

Command

An instruction which you give your operating system. Example: run a particular application or format a floppy disk.

Configuration

The combination of hardware and software that makes up your system and how it is allocated for use.

Data

The information a system stores and processes.

DC

Direct current. A voltage or current that does not fluctuate periodically with time.

Default Value

A pre-programmed value to be used if you fail to set your own.

DHCP

Dynamic Host Configuration Protocol. A protocol used to automatically acquire parameters required for the communication, such as IP address. The sender of IP address is called a DHCP server, and the receiver is called a DHCP client.

DIMM

Dual-in-line memory module.

Disk

A spinning platter of magnetic data storage media. If the platter is very stiff it is a hard drive, if it is highly flexible it is a floppy disk, if it is a floppy disk in a hard housing with a shutter it is commonly called a diskette.

Disk Drive

The hardware which spins the disk and has the heads and control circuitry for reading and writing the data on the disk.

Diskette

A floppy disk in a hard housing with a shutter.

DMA

Direct Memory Access. Special circuitry for memory to memory transfers of data which do not require CPU action.

DMI

Desktop Management Interface. A standard that provides PC management applications with a common method of locally or remotely querying and configuring PC computer systems, hardware and software components, and peripherals.

DNS

Domain Name System. A function to control the association between the IP address and the name assigned to the computer. If you do not know the IP address but if you know the computer name, you can still communicate to that computer.

DOS

Disk Operating System (MS-DOS is a Microsoft Disk Operating System).

Driver

A computer program which converts application and operating system commands to external devices into the exact form required by a specific brand and model of device in order to produce the desired results from that particular equipment.

DVMT

Dynamic Video Memory Technology. A video memory architecture that increases the efficiency of the motherboard by using innovative memory utilization and direct AGP.

Encryption Key (Network Key)

Data encryption key used to encrypt message text and for computing message integrity checks. Data encryption protects data from unauthorized viewing.

This device uses the same encryption key to encode and decode the data, and the identical encryption key is required between the sender and receiver.

ESD

Electrostatic Discharge. The sudden discharge of electricity from a static charge which has built-up slowly. Example: the shock you get from a doorknob on a dry day or the sparks you get from brushing hair on a dry day.

FCC

Federal Communication Commission.

GB

Gigabyte. One billion bytes.

Hard drive

A spinning platter of magnetic data storage media where the platter is very stiff.

I/O

Input/Output. Data entering and leaving your notebook in electronic form.

I/O Port

Connector and associated control circuits for data entering and leaving a notebook in electronic form.

IDE

Intelligent Drive Electronics. A type of control interface for a hard drive which is inside the hard drive unit.

IEEE802.11a

Wireless LAN standard that supports a maximum data rate of 54 Mbps. 802.11a devices operate in the 5 GHz lower and middle UNII bands.

IEEE802.11b

Wireless LAN standard that supports a maximum data rate of 11 Mbps. 802.11b devices operate in the 2.4 GHz ISM band.

IEEE802.11g

Wireless LAN standard that supports a maximum data rate of 54 Mbps. 802.11g devices operate in the 2.4 GHz ISM band.

Infrastructure

A name of a wireless LAN configuration. This type of communication uses an access point. Another type of communication is called Ad Hoc.

IP Address

An identifier for a computer or device on a TCP/IP network. Networks using the TCP/IP protocol route messages based on the IP address of the destination. The format of an IP address is a 32-bit numeric address written as four numbers separated by periods. Each number can be zero to 255. For example, 1.160.10.240 could be an IP address.

Within an isolated network, you can assign IP addresses at random as long as each one is unique. However, connecting a private network to the Internet requires using registered IP addresses (called Internet addresses) to avoid duplicates.

The four numbers in an IP address are used in different ways to identify a particular network and a host on that network. Three regional Internet registries -- ARIN, RIPE NCC and APNIC -- assign Internet addresses from the following three classes.

Class A - supports 16 million hosts on each of 126 networks

Class B - supports 65,000 hosts on each of 16,000 networks

Class C - supports 254 hosts on each of 2 million networks

The number of unassigned Internet addresses is running out, so a new classless scheme called CIDR is gradually replacing the system based on classes A, B, and C and is tied to adoption of IPv6.

IRQ

Interrupt Request. An acronym for the hardware signal to the CPU that an external event has occurred which needs to be processed.

KB

Kilobyte. One thousand bytes.

LAN

Local Area Network. An interconnection of computers and peripherals within a single limited geographic location which can pass programs and data amongst themselves.

LCD

Liquid Crystal Display. A type of display which makes images by controlling the orientation of crystals in a crystalline liquid.

Lithium ion Battery

A type of rechargeable battery which has a high power-time life for its size and is not subject to the memory effect as Nickel Cadmium batteries.

MAC Address

Media Access Control Address. A unique physical address of a network card. For Ethernet, the first three bytes are used as the vendor code, controlled and assigned by IEEE. The remaining three bytes are controlled by each vendor (preventing overlap), therefore, every Ethernet card is given a unique physical address in the world, being assigned with a different address from other cards. For Ethernet, frames are sent and received based on this address.

MB

Megabyte. One million bytes.

Megahertz

1,000,000 cycles per second.

Memory

A repository for data and applications which is readily accessible to your notebook's CPU.

MHz

Megahertz.

MIDI

Musical Instrument Digital Interface. A standard communication protocol for exchange of information between computers and sound producers such as synthesizers.

Modem

A contraction for MODulator-DEModulator. The equipment which connects a computer or other data terminal to a communication line.

Monaural

A system using one channel to process sound from all sources.

MTU

Maximum Transmission Unit

The maximum data size that can be transferred at a time through the Internet or other networks. You can set a smaller MTU size to obtain successful communication, if you have difficulty transferring data due to the fact that the maximum size is too large.

Network key

Data that is used for encrypting data in data communication. The personal computer uses the same network key both for data encryption and decryption, therefore, it is necessary to set the same network key as the other side of communication.

Network name (SSID: Service Set Identifier)

When a wireless LAN network is configured, grouping is performed to avoid interference or data theft. This grouping is performed with "Network name (SSID)". In order to improve security, the network key is set allowing no communication unless "Network name (SSID)" coincides with the network key.

Open system authentication

Null authentication method specified in the 802.11 standard that performs no authentication checks on a wireless client before allowing it to associate.

Operating System

A group of control programs that convert application commands, including driver programs, into the exact form required by a specific brand and model of microprocessor in order to produce the desired results from that particular equipment.

Partition

A block of space on a hard drive which is set aside and made to appear to the operating system as if it were a separate disk, and addressed by the operating system accordingly.

Peripheral Device

A piece of equipment which performs a specific function associated with but not integral to a computer. Examples: a printer, a modem, a CD-ROM.

Pitch (keyboard)

The distance between the centers of the letter keys of a keyboard.

Pixel

The smallest element of a display, a dot of color on your display screen. The more pixels per area the clearer your image will appear.

POST

Power On Self Test. A program which is part of the BIOS which checks the configuration and operating condition of your hardware whenever power is applied to your notebook. Status and error messages may be displayed before the operating system is loaded. If the self test detects failures that are so serious that operation can not continue, the operating system will not be loaded.

PPPoE

Point to Point Protocol over Ethernet. A protocol for Ethernet, using a Point-to-Point Protocol (PPP), which is used for connection on the phone line.

Program

An integrated set of coded commands to your computers telling your hardware what to do and how and when to do it.

Protocol

Procedures and rules use to send and receive data between computers.

- Method of sending and receiving data
- Process used to handle communication errors

Conditions required for communication are organized in procedures for correct transfer of information.

RAM

Random Access Memory. A hardware component of your notebook that holds binary information (both program and data) as long as it has the proper power applied to it.

RAM Module

A printed circuit card with memory and associated circuitry which allows the user to add additional memory to the computer without special tools.

Reset

The act of reloading the operating system. A reset erases all information stored in RAM.

Restart

See Reset.

Resume

To proceed after interruption. In your notebook this refers to returning to active operation after having been in one of the suspension states.

SDRAM

Synchronous Dynamic Random Access Memory.

Serial Port

A connection to another device through which data is transferred one bit at a time on a single wire with any other wires only for control of the device not for transfer of data.

Shared key authentication

802.11 network authentication method in which the AP sends the client device a challenge text packet that the client must then encrypt with the correct WEP key and return to the AP. If the client has the wrong key or no key, authentication will fail and the client will not be allowed to associate with the AP. Shared key authentication is not considered secure, because a hacker who detects both the clear-text challenge and the same challenge encrypted with a WEP key can decipher the key.

SSID

Service Set Identifier, a 32-character unique identifier attached to the header of packets sent over a WLAN that acts as a password when a mobile device tries to connect to the BSS. The SSID differentiates one WLAN from another, so all access points and all devices attempting to connect to a specific WLAN must use the same SSID. A device will not be permitted to join the BSS unless it can provide the unique SSID. Because the SSID is broadcast in plain text, it does not supply any security to the network.

Standby

To make inoperative for a period of time. Your notebook uses various suspension states to reduce power consumption and prolong the charge of your battery.

Status Indicator

A display which reports the condition of some portion of your hardware. On your notebook this is an LCD screen just above the keyboard.

Stereo (audio)

A system using two channels to process sound from two different sources.

Subnet mask

TCP-IP network is controlled by being divided into multiple smaller networks (subnets). IP address consists of the subnet address and the address of each computer. Subnet mask defines how many bits of IP address comprise the subnet address. The same value shall be set among computers communicating with each other.

SVGA

Super VGA.

S-Video

Super Video. A component video system for driving a TV or computer monitor.

System Clock

An oscillator of fixed precise frequency which synchronizes the operation of the system and is counted to provide time of day and date.

TCP/IP

Transmission Control Protocol/Internet Protocol. A standard Internet protocol that is most widely used.

TFT

Thin Film Transistor – A technology for flat display panels which uses a thin film matrix of transistors to control each pixel of the display screen individually.

UL

Underwriters Laboratories – An independent organization that tests and certifies the electrical safety of devices.

USB

Universal Serial Bus. Standard that allows you to simultaneously connect up to 127 USB devices such as game pads, pointing devices, printers, and keyboards to your computer.

VRAM

Video Random Access Memory. A memory dedicated to video display data and control.

WFM

Wired for Management is Intel's broad-based initiative to reduce the total cost of ownership (TCO) of business computing without sacrificing power and flexibility.

Wi-Fi Compatible

Wi-Fi (Wireless Fidelity) Identifies that the product has passed the interoperability test, supplied by the WECA (Wireless Ethernet Compatibility Alliance), which guarantees the interoperability of wireless IEEE 802.11 LAN products. For more information on the Wi-Fi standard, go to the WECA Web site at: www.wirelessethernet.com.

WLAN

Wireless Local Area Network. A wireless interconnection of computers and peripherals within a single limited geographic location which can pass programs and data amongst themselves.

Regulatory Information

Notice

Changes or modifications not expressly approved by Fujitsu could void this user's authority to operate the equipment.

FCC NOTICES

Notice to Users of Radios and Television

This equipment has been tested and found to comply with the limit for class B digital devices, pursuant to parts 15 of the FCC Rules.

These limits are designed to provide reasonable protection against harmful interference in a residential installation. This equipment generates, uses, and can radiate radio frequency energy and, if not installed and used in accordance with the instructions, may cause harmful interference to radio communications. However, there is no guarantee that interference will not occur in a particular installation. If this equipment does cause harmful interference to radio or television reception, which can be determined by turning the equipment off and on, the user is encouraged to try to correct the interference by one or more of the following measures:

- Reorient or relocate the receiving antenna.
- Increase the separation between the equipment and receiver.
- Connect the equipment into an outlet that is on a different circuit than the receiver.
- Consult the dealer or an experienced radio/TV technician for help.

Shielded interconnect cables must be employed with this equipment to ensure compliance with the pertinent RF emission limits governing this device.

DOC (INDUSTRY CANADA) NOTICES

Notice to Users of Radios and Television

This Class B digital apparatus meets all requirements of Canadian Interference-Causing Equipment Regulations.

CET appareil numérique de la class B respecte toutes les exigence du Règlement sur le matériel brouilleur du Canada.



Appendix A: WLAN User's Guide

FC FCC Regulatory Information

Please note the following regulatory information related to the optional wireless LAN device.

Regulatory Notes and Statements

Wireless LAN, Health and Authorization for use

Radio frequency electromagnetic energy is emitted from Wireless LAN devices. The energy levels of these emissions, however, are much less than the electromagnetic energy emissions from wireless devices such as mobile phones. Wireless LAN devices are safe for use by consumers because they operate within the guidelines found in radio frequency safety standards and recommendations. The use of Wireless LAN devices may be restricted in some situations or environments, such as:

- On board an airplane, or
- In an explosive environment, or
- In situations where the interference risk to other devices or services is perceived or identified as harmful.

In cases in which the policy regarding use of Wireless LAN devices in specific environments is not clear (e.g., airports, hospitals, chemical/oil/gas industrial plants, private buildings), obtain authorization to use these devices prior to operating the equipment.

Regulatory Information/Disclaimers

Installation and use of this Wireless LAN device must be in strict accordance with the instructions included in the user documentation provided with the product. Any changes or modifications made to this device that are not expressly approved by the manufacturer may void the user's authority to operate the equipment. The manufacturer is not responsible for any radio or television interference caused by unauthorized modification of this device, or the substitution or attachment of connecting cables and equipment other than those specified by the manufacturer. It is the responsibility of the user to correct any interference caused by such unauthorized modification, substitution or attachment. The manufacturer and its authorized resellers or distributors will assume no liability for any damage or violation of government regulations arising from failure to comply with these guidelines.

This device must not be co-located or operated in conjunction with any other antenna or transmitter.

For IEEE 802.11a Wireless LAN: For operation within 5.15~5.25 GHz frequency range, it is restricted to indoor environments, and the antenna of this device must be integral.

Federal Communications Commission statement

This device complies with Part 15 of FCC Rules.

Operation is subject to the following two conditions: (1) This device may not cause interference, and, (2) This device must accept any interference, including interference that may cause undesired operation of this device.

FCC Interference Statement

This equipment has been tested and found to comply with the limits for a Class B digital device, pursuant to Part 15 of the FCC Rules. These limits are designed to provide reasonable protection against harmful interference in a residential installation. This equipment generates, uses, and can radiate radio frequency energy. If not installed and used in accordance with the instructions, it may cause harmful interference to radio communications. However, there is no guarantee that interference will not occur in a particular installation.

If this equipment does cause harmful interference to radio or television reception, which can be determined by turning the equipment off and on, the user is encouraged to try and correct the interference by one or more of the following measures:

- 1** Reorient or relocate the receiving antenna.
- 2** Increase the distance between the equipment and the receiver.
- 3** Connect the equipment to an outlet on a circuit different from the one the receiver is connected to.
- 4** Consult the dealer or an experienced radio/TV technician for help.

FCC Radio Frequency Exposure statement

The available scientific evidence does not show that any health problems are associated with using low power wireless devices. There is no proof, however, that these low power wireless devices are absolutely safe. Low power wireless devices emit low levels of radio frequency energy (RF) in the microwave range while being used. Whereas high levels of RF can produce health effects (by heating tissue), exposure to low-level RF that does not produce heating effects causes no known adverse health effects. Many studies of low-level RF exposure have not found any biological effects. Some studies have suggested that some biological effects might occur, but such findings have not been confirmed by additional research. The wireless LAN radio device has been tested and found to comply with FCC radiation exposure limits set forth for an uncontrolled equipment and meets the FCC radio frequency (RF) Exposure Guidelines in Supplement C to OET65.

Export restrictions

This product or software contains encryption code which may not be exported or transferred from the US or Canada without an approved US Department of Commerce export license. This device complies with Part 15 of FCC Rules., as well as ICES 003 B / NMB 003 B. Operation is subject to the following two conditions: (1) this device may not cause harmful interference, and (2) this device must accept any interference received, including interference that may cause undesirable operation. Modifications not expressly authorized by Fujitsu America Inc. may invalidate the user's right to operate this equipment.

Canadian Notice

The device for the 5150 - 5250 MHz band is only for indoor usage to reduce the potential for harmful interference to co-channel mobile satellite systems.

The maximum antenna gain of 6 dBi permitted (for devices in the 5250 - 5350 MHz, 5470 - 5725 MHz and 5725 - 5825 MHz bands) to comply with the e.i.r.p. limit as stated in A9.2 of RSS210.

In addition, users are cautioned to take note that high power radars are allocated as primary users (meaning they have priority) of 5250 - 5350 MHz and 5650 - 5850 MHz and these radars could cause interference and/or damage to LE-LAN devices.

Before Using the Optional Wireless LAN

This manual describes the procedures required to properly set up and configure the optional integrated Wireless LAN Mini-PCI device (referred to as "WLAN device" in the rest of the manual). Before using the WLAN device, read this manual carefully to ensure its correct operation. Keep this manual in a safe place for future reference.

Wireless LAN Device Covered by this Document

This document is applicable to systems containing the following optional device:

- Integrated Atheros Align™ 802.11bgn

Characteristics of the WLAN Device

- The WLAN device is a Mini-PCI card attached to the main board of the mobile computer.
- The WLAN device operates in license-free RF bands, eliminating the need to procure an FCC operating license. The WLAN operates in the 2.4 GHz Industrial, Scientific, and Medical (ISM) RF band.
- The WLAN devices are capable of two operating modes: IEEE802.11b and IEEE802.11g
- The WLAN devices are Wi-Fi certified and operate (as applicable) at 54 Mbps in IEEE802.11g mode and 11 Mbps in IEEE802.11b mode.
- The WLAN devices support the following encryption methods - WEP, TKIP, CKIP, and AES encryption.
- The Wireless LAN devices are compliant with the following standards: WPA, WPA2, CCX1.0, CCX2.0, CCX3.0, and CCX4.0.

Wireless LAN Modes Using this Device

Ad Hoc Mode

"Ad Hoc Mode" refers to a wireless network architecture where wireless network connectivity between multiple computers is established without a central wireless network device, typically known as Access Point(s). Connectivity is accomplished using only client devices in a peer-to-peer fashion. That is why Ad Hoc networks are also known as peer-to-peer networks. Ad Hoc networks are an easy and inexpensive method for establishing network connectivity between multiple computers. Ad Hoc mode requires that the SSID, network authentication, and encryption key settings are identically configured on all computers in the Ad Hoc network.

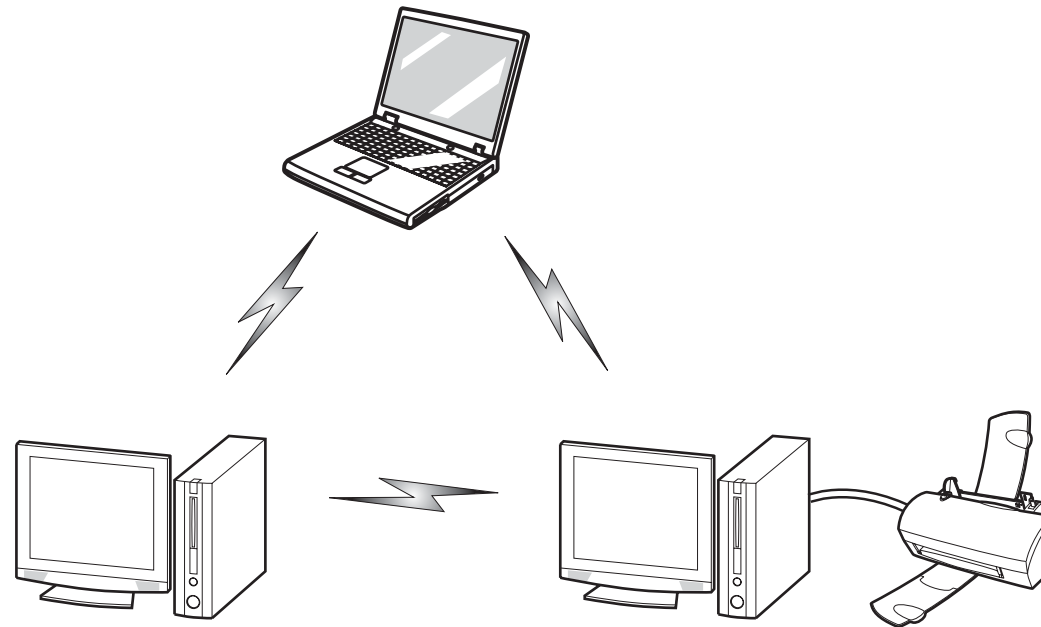

Figure 20. Ad Hoc Mode Network

Access Point (Infrastructure) Mode

Infrastructure mode refers to a wireless network architecture in which devices communicate with wireless or wired network devices by communicating through an Access Point. In infrastructure mode, wireless devices can communicate with each other or with a wired network. Corporate wireless networks operate in infrastructure mode because they require access to the WLAN in order to access services, devices, and computers (e.g., file servers, printers, databases).

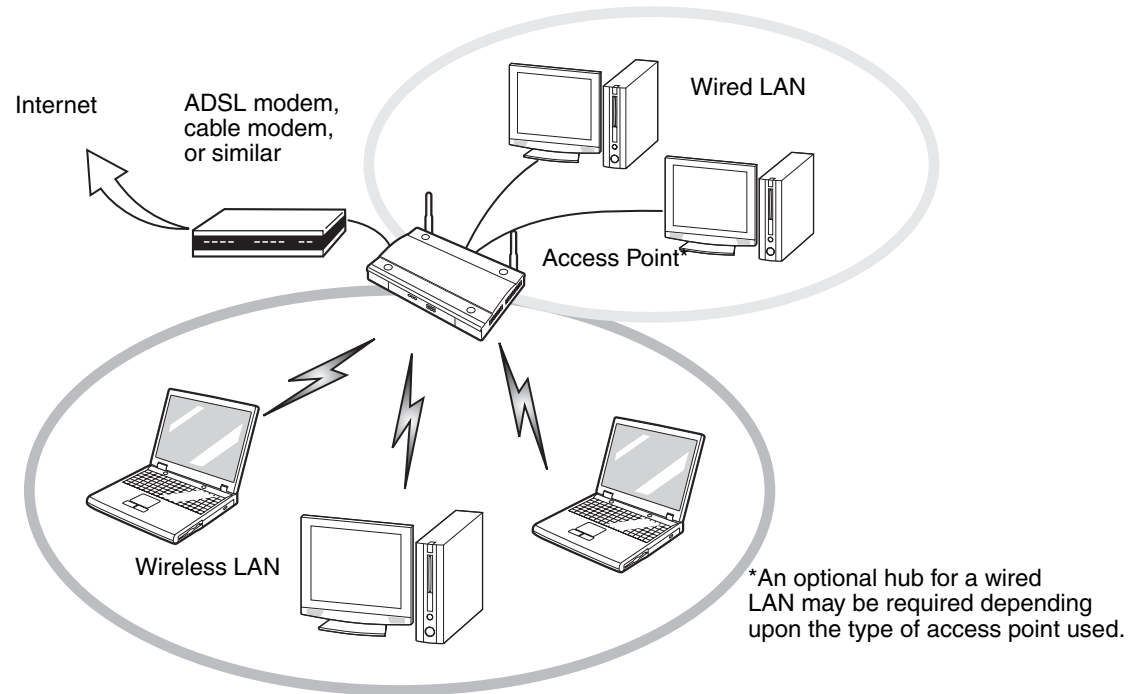

Figure 21. Access Point (Infrastructure) Mode Network

How to Handle This Device

The WLAN device is an optional device that may come pre-installed in your mobile computer. Under normal circumstances, it should not be necessary for you to remove or re-install it. The operating system that your mobile computer comes with has been pre-configured to support the WLAN device.

- The Wireless LAN devices support IEEE802.11b and IEEE802.11g.
- The WLAN devices operate in the 2.4 GHz ISM band.
- Microwave ovens may interfere with the operation of WLAN devices since they operate in the same 2.4 GHz frequency range as IEEE802.11 b/g devices.
- Wireless devices that transmit in the 2.4 GHz range may interfere with operation of WLAN devices in IEEE802.11 b/g modes. Symptoms of interference include reduced throughput, intermittent disconnects, and many frame errors. It is HIGHLY recommended that these interfering devices be powered off to ensure proper operation of the WLAN device.

Deactivating the WLAN Device

Deactivating the WLAN device may be desired in certain circumstances (to extend battery life) or where certain environments require it (i.e. hospitals, clinics, airplanes, etc.). The WLAN device can be deactivated in Windows using the WLAN On/Off key (Fn + F5). Note that disconnecting via the icon in the system tray does not turn off the radio; it continues to transmit and receive even though it's not connected.



BEFORE USING THE WIRELESS LAN DEVICE, YOU MUST FIRST INSTALL CLICKME! TO ENSURE THAT THE CORRECT SOFTWARE FOR YOUR DEVICE IS INSTALLED. SEE "INSTALLING CLICKME!" ON PAGE 73.

Disconnection Using the Icon in the Taskbar

Note that disconnecting via the icon in the system tray does not turn off the radio; it continues to transmit and receive even though it's not connected.

- 1 Right-click the WLAN icon in the taskbar at the bottom right of your screen.
- 2 Choose Disconnect from a network.

Activating the WLAN Device

Activation of the WLAN device can be accomplished using the same methods as the deactivation process, by right-clicking the WLAN icon then clicking “Connect to a network”, or by using the WLAN On/Off key combination (Fn + F5).

Configuring the Wireless LAN

The optional WLAN device can be configured to establish wireless network connectivity using the software that is built into Windows for most industry standard security solutions is contained in this software.

Pre-defined parameters will be required for this procedure. Please consult with your network administrator for these parameters:

Configuring the WLAN using Windows XP

Procedure

- 1 Click the Start button, then select Control Panel.
- 2 If the Control Panel is not in Classic View, select Classic View from the left panel. Double-click the Network Connections icon.
- 3 Double-click on the Wireless Network Connection icon.
- 4 Choose a wireless network.
- 5 Click [Connect].
- 6 Enter the Network Key, if required.
- 7 Enter any required information. It may be necessary to consult with your network administrator for some of the information.
- 8 In the event you require assistance, go to [Start] -> Help and Support -> Networking and the Web. Select the main topic in which you are interested, then type in relevant keywords in the Search box.

Connection to the network

After you have configured your computer, you can connect to an active network by clicking on the Wireless Network icon in the system tray:

Troubleshooting the WLAN

Troubleshooting

Causes and countermeasures for troubles you may encounter while using your wireless LAN are described in the following table. If you are unfamiliar with the steps required, consult your System Administrator or go to [Start] -> Help and Support -> Networking and the Web

Problem	Possible Cause	Possible Solution
Unavailable network connection	Incorrect network name (SSID) or network key	Ad hoc connection: verify that the network names (SSID's) and network keys (WEP) of all computers to be connected have been configured correctly. SSID's and WEP key values must be identical on each machine. Access Point (Infrastructure) connection: set network name (SSID) and network key to the same values as those of the access point. Set the Network Authentication value identically to that of the Access Point. Please consult your network administrator for this value, if necessary.
	Weak received signal strength and/or link quality	Ad hoc connection: Retry connection after shortening the distance to the destination computer or removing any obstacles for better sight. Access Point (Infrastructure) connection: Retry connection after shortening the distance to the access point or removing any obstacles for better transmission.
	The WLAN device has been deactivated or disabled	Go to Start -> Control Panel, and double-click on Windows Mobility Center. If the wireless network is off, click the [Turn wireless on] button.
	The computer to be connected is turned off	Check if the computer to be connected is turned ON.

Problem	Possible Cause	Possible Solution
Unavailable network connection (continued)	RF interference from Access Points or other wireless networks	The use of identical or overlapping RF channels can cause interference with the operation of the WLAN device. Change the channel of your Access Point to a channel that does not overlap with the interfering device.
	Wireless network authentication has failed	Re-check your Network Authentication, Encryption, and Security settings. Incorrectly configured security settings such as an incorrectly typed WEP key, a mis-configured LEAP username, or an incorrectly chosen authentication method will cause the LAN device to associate but not authenticate to the wireless network.
	Incorrectly configured network settings	Recheck the configuration of your network settings.
	Incorrect IP address configuration	This only applies to networks using static IP addresses. Please contact your network administrator for the correct settings.

WLAN Specifications

Specifications

Item	Specification
Type of network	The integrated Atheros Align™ 802.11bgn Wireless LAN device conforms to 802.11b, 802.11g, and 802.11n Wi-Fi based*.
Transfer rate	(Automatic switching) 54 Mbps maximum data rate
Active frequency	<ul style="list-style-type: none"> • 802.11n (draft): 2.4 GHz or 5 GHz • 802.11b/g: 2400~2473 MHz
Typical operating distances**	<ul style="list-style-type: none"> • 802.11b: 100 ft. (30 m) @ 11 Mbps; 300 ft. (91 m) @ 1 Mbps • 802.11g: 100 ft. (30 m) @ 54 Mbps; 300 ft. (91 m) @ 1 Mbps • 802.11n (draft): Estimated double the operating distance of 802.11g and 802.11b in their respective frequencies.
Number of channels	<ul style="list-style-type: none"> • 802.11b/g: 11 channels, 3 non-overlapping channels • 802.11n (draft): 2.4 GHz - 3 non-overlapping channels when Channel Bonding is not used; 2 non-overlapping channels when Channel Bonding is used. 5 GHz - 12 non-overlapping UNII channels with or without Channel Bonding
Security	Encryption Types - WEP, TKIP, AES***, WPA 1.0 compliant Encryption Key lengths Supported: 64 bits and 128 bits 802.1x/EAP
Maximum recommended number of computers to be connected over wireless LAN (during ad hoc connection)	10 units or less ****

- * “Wi-Fi based” indicates that the interconnectivity test of the organization which guarantees the interconnectivity of wireless LAN (Wi-Fi Alliance) has been passed.
- ** The communication ranges shown above will increase or decrease depending on factors such as number of walls, reflective material, or interference from external RF sources.
- *** Encryption with network key (WEP) is performed using the above number of bits, however, users can set 40 bits/ 104 bits after subtracting the fixed length of 24 bits.
- **** Depending on practical environments, the allowable number of computers to be connected may be decreased.

Using the Bluetooth Device

The Integrated Bluetooth module (QBTM400) is an optional device available for Fujitsu mobile computers.

What is Bluetooth

Bluetooth technology is designed as a short-range wireless link between mobile devices, such as laptop computers, phones, printers, and cameras. Bluetooth technology is used to create Personal Area Networks (PANs) between devices in short-range of each other.



TO ENABLE OR DISABLE EITHER THE WIRELESS LAN OR BLUETOOTH DEVICES INDIVIDUALLY, PERFORM THE FOLLOWING STEPS:

- 1** Press the WLAN On/Off key combination (Fn + F5) on the keyboard.
- 2** Go to Start > **All Programs** > **Bluetooth**.
- 3** Click on **Options** under the Bluetooth menu and click on the **Bluetooth Radio Power** button.
- 4** Click [OK].

Where to Find Information About Bluetooth

The Bluetooth module contains a robust Help user's guide to assist you in learning about operation of the Bluetooth device.

To access the Help file, click [Start] > All Programs, and click on Toshiba. Select Bluetooth, then select User's Guide.

For additional information about Bluetooth Technology, visit the Bluetooth Web site at: www.bluetooth.com.

FCC Radiation Exposure Statement

This equipment complies with FCC radiation exposure limits set forth for an uncontrolled environment. The Bluetooth antenna is located on the front edge of the right palm rest and is exempt from minimum distance criteria due to its low power.

The transmitters in this device must not be co-located or operated in conjunction with any other antenna or transmitter.

Canadian Notice

To prevent radio interference to the licensed service, this device is intended to be operated indoors and away from windows to provide maximum shielding. Equipment (or its transmit antenna) that is installed outdoors is subject to licensing.

Warranty

Users are not authorized to modify this product. Any modifications invalidate the warranty.

This equipment may not be modified, altered, or changed in any way without signed written permission from Fujitsu. Unauthorized modification will void the equipment authorization from the FCC and Industry Canada and the warranty.

Index

A

About This Guide 1, 14
AC
 adapter 42
 plug adapters 88
Air Vents 27
Anti-theft Lock Slot 26
Auto/Airline Adapter 42

B

Battery 53
 alarm 55
 care 89
 Charge/DC-In Indicator 29
 cold-swapping 56
 conserving power 48
 dead 73
 faulty 73
 hot-swapping 56
 increasing life 89
 lithium ion battery 53
 low 55
 problems 73, 74
 recharging 54
 replacing 55
 suspend mode 55
Battery Latches 26

BIOS

 guide 45
 setup utility 44

Bluetooth

 Where to Find Information 127

Boot Sequence 44

Booting the System 45

Built-in Speakers 70

C

CapsLock Indicator 30

Click Me! 47

Clicking 37

Configuration Label 91

Contact Information 15

Controls and Connectors 18

Conventions Used in the Guide 14

Cursor 36

Cursor Keys 34

D

DC in connector 18

DC Output Cable 42

DC Power Jack 42

Display Panel 21, 31

 brightness 32

 opening 31

 problems 75, 76

Double-Clicking 38
Dragging 39
Drivers and Application Restore CD 80

E

Error Messages 77
External Monitor Port 23, 65
External Video port 19

F

FDU 47, 82, 97
Fujitsu Contact Information 15
Fujitsu Driver Update utility 47, 82, 97
Fujitsu LifeBook
 storing 86
 traveling 88
Fujitsu Shopping Online 16
Function Key
 F10 35
 F3 35
 F5 35
 F6 35
 F7 35
 F8 35
 F9 35

G

Glossary 98

H

Hard Disk Drive
 access indicator 30
 problems 70
Hard Disk Drive Passwords 44
Headphone Jack 18, 25, 64

Hibernation Feature 50
 disable/enable 50

I

Installing a Memory Stick 63

K

Keyboard 21, 33
 cursor keys 34
 numeric keypad 33
 problems 70
 windows keys 34

L

LAN (RJ-45) Jack 24
Lithium ion Battery Bay 27
Local Area Network (LAN) 19

M

Memory
 capacity 61
 checking capacity 61
 compartment 27, 60
 installing 59
 problems 71
 removing 61
 upgrade module 58
Memory Stick
 installing 63
Microphone Jack 18, 26, 65
Microsoft Works 97
Mouse problems 70

N

NumLk Indicator 30

O

Optical drive, care 90

P

Power

- AC adapter 42
- Auto/Airline adapter 42
- failure 72
- indicator 29
- management 48
- off 51
- on 43
- problems 74
- sources 42

Power Management 48

Power On Self Test 43, 77

Power/Suspend/Resume Button 48

Pre-Installed Software 96

- Adobe Acrobat Reader 96
- manuals 96

R

Registration 47

Regulatory Information 112

Removing a Memory Stick 63

Restarting 50

Restoring Your Pre-installed Software 80

RJ-45 19, 64

S

SD Card Slot 18

SD Cards

- removing 63

SDRAM 27, 58

Secure Digital Cards 62

Security lock slot 18

Sleep Mode 49

Specifications 91

Audio 93

Chipset 92

Device Ports 94

Dimensions and Weight 95

Environmental Requirements 95

Keyboard 94

mass storage device options 93

Memory 92

Microprocessor 92

Power 94

Video 92

status indicators 21, 28

Suspend/Resume Button 19, 21

T

Touchpad 36

buttons 36

controls 39

Troubleshooting 67

U

Universal Serial Bus Port 65

USB 65, 71

problems 71

USB 2.0 Ports 18, 24, 26

V

Volume control 40

W

Warranty 16

- Windows keys 34
 - Application key 34
 - Start key 34
- Windows Power Management 50
- Windows XP
 - configuring the Wireless LAN 122
 - starting the first time 46
- Wireless LAN
 - Before Using the Wireless LAN 117
 - configuring 117
 - connection to the network 122
 - deactivating/disconnecting 120
 - modes 118
 - Specifications 125
 - Troubleshooting 123
- Wireless LAN/Bluetooth On/Off Switch 19