

APPENDIX H
USER MANUAL

User's Guide

Learn how to use your
Fujitsu Stylistic
ST6010 Tablet PC

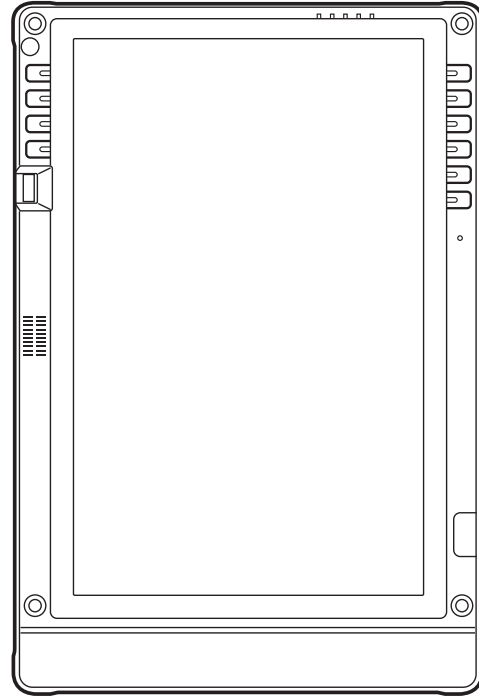

FUJITSU

THE POSSIBILITIES ARE INFINITE



Copyright and Trademark Information

Fujitsu Computer Systems Corporation has made every effort to ensure the accuracy and completeness of this document. Because ongoing development efforts are made to continually improve the capabilities of our products, however, the data contained herein represents Fujitsu design objectives and is provided for comparative purposes; actual results may vary based on a variety of factors. This product data does not constitute a warranty. Specifications are subject to change without knowledge.

Fujitsu and the Fujitsu logo are registered trademarks of Fujitsu Limited; Stylistic is a registered trademark of Fujitsu Computer Systems Corporation.

Microsoft, Windows, and Windows Vista are registered trademarks or trademarks of Microsoft Corporation in the United States and/or other countries.

PCMCIA and CardBus are registered trademarks of the Personal Computer Memory Card International Association.

Centrino, Intel, and Intel Core are trademarks or registered trademarks of Intel Corporation or its subsidiaries in the United States and other countries.

OmniPass is a trademark of Softex, Inc.

Adobe, Acrobat, and Acrobat Reader are either registered trademarks or trademarks of Adobe Systems Incorporated in the United States and/or other countries.

Atheros and Super AG are registered trademarks of Atheros Communications, Inc.

SigmaTel is a registered trademark of SigmaTel, Inc.

Bluetooth and the Bluetooth logo are registered trademarks of Bluetooth SIG, Inc.

Memory Stick is a registered trademark of Sony Corporation and/or its affiliates

Wi-Fi is a trademark of the Wireless Ethernet Compatibility Alliance (WECA).

All other products are trademarks or registered trademarks of their respective companies. All other trademarks mentioned herein are the property of their respective owners.

WARNING



HANDLING THE CORD ON THIS PRODUCT WILL EXPOSE YOU TO LEAD, A CHEMICAL KNOWN TO THE STATE OF CALIFORNIA TO CAUSE BIRTH DEFECTS OR OTHER REPRODUCTIVE HARM.

WASH HANDS AFTER HANDLING.

Copyright 2008 Fujitsu Computer Systems Corporation. All rights reserved. No part of this publication may be copied, reproduced, or translated, without the prior written consent of Fujitsu Computer Systems Corporation. No part of this publication may be stored or transmitted in any electronic form without the prior consent of Fujitsu Computer Systems Corporation.

B5FJ-DRAFT-01EN-00



DECLARATION OF CONFORMITY

according to FCC Part 15

Responsible Party Name: Fujitsu Computer Systems Corporation

Address: 1250 E. Arques Avenue, MS 122
Sunnyvale, CA 94085

Telephone: 408-746-6000

Declares that product: Model Series: Stylistic® ST6010 Tablet PC

Complies with Part 15 of the FCC Rules

This device complies with Part 15 of the FCC rules. Operation is subject to the following two conditions: (1) This device may not cause harmful interference, and, (2) This device must accept any interference received, including interference that may cause undesired operation.

IMPORTANT SAFETY INSTRUCTIONS

This unit requires an AC adapter to operate. Use only UL Listed I.T.E. Class II Adapters with an output rating of 16 VDC, with a current of 3.75 A (60 W).

AC adapter output polarity:



When using your notebook equipment, basic safety precautions should always be followed to reduce the risk of fire, electric shock and injury to persons, including the following:

- Do not use this product near water for example, near a bathtub, washbowl, kitchen sink or laundry tub, in a wet basement or near a swimming pool.
- Avoid using a modem during an electrical storm. There may be a remote risk of electric shock from lightning.
- Do not use a modem to report a gas leak in the vicinity of the leak.
- Use only the power cord and batteries indicated in this manual. Do not dispose of batteries in a fire. They may explode. Check with local codes for possible special disposal instructions.
- To reduce the risk of fire, use only No. 26 AWG or larger UL Listed or CSA Certified Telecommunication Line Cord.
- For TV tuner use: To protect from overvoltages and transients on the Cable Distribution System, make sure that the outer shield of the coaxial cable is connected to earth (grounded) at the building premise as close to the point of cable entrance as practicable, as required per NEC Article 820.93, ANSI/NFPA 70: 2005. If you have questions about your CATV installation, contact your service provider.

SAVE THESE INSTRUCTIONS

For Authorized Repair Technicians Only



DANGER OF EXPLOSION IF LITHIUM (CLOCK) BATTERY IS INCORRECTLY REPLACED. REPLACE ONLY WITH THE SAME OR EQUIVALENT TYPE RECOMMENDED BY THE MANUFACTURER. DISPOSE OF USED BATTERIES ACCORDING TO THE MANUFACTURER'S INSTRUCTION.



FOR CONTINUED PROTECTION AGAINST RISK OF FIRE, REPLACE ONLY WITH THE SAME TYPE AND RATING FUSE.

Recycling your battery

Over time, the batteries that run your mobile computer will begin to hold a charge for a shorter amount of time; this is a natural occurrence for all batteries. When this occurs, you may want to replace the battery with a fresh one*. If you replace it, it is important that you dispose of the old battery properly because batteries contain materials that could cause environmental damage if disposed of improperly.



Fujitsu is very concerned with environmental protection, and has enlisted the services of the Rechargeable Battery Recycling Corporation (RBRC)**, a non-profit public service organization dedicated to protecting our environment by recycling old batteries at no cost to you.

RBRC has drop-off points at tens of thousands of locations throughout the United States and Canada. To find the location nearest you, go to www.RBRC.org or call 1-800-822-8837.

If there are no convenient RBRC locations near you, you can also go to the EIA Consumer Education Initiative website (<http://EIAE.org/>) and search for a convenient disposal location.

Remember – protecting the environment is a cooperative effort, and you should make every effort to protect it for current and future generations.

* To order a new battery for your Fujitsu mobile computer, go to the Fujitsu shopping site at www.shopfujitsu.com in the US or www.fujitsu.ca/products/notebooks in Canada.

** RBRC is an independent third party to which Fujitsu provides funding for battery recycling; RBRC is in no way affiliated with Fujitsu.

ENERGY STAR® Compliance



Your Fujitsu system is an ENERGY STAR® qualified mobile PC. By choosing a computer with the latest energy-saving technology, you're helping to preserve our environment for future generations.

ENERGY STAR is a joint program of the U.S. Environmental Protection Agency, U.S. Department of Energy, Natural Resources Canada, and other governments around the world helping us save money while protecting the environment through energy efficient products and practices. With energy costs and global warming top-of-mind for consumers, Fujitsu is committed to offering solutions that help consumers conserve energy and improve the quality of our environment.

Sleep Mode:

You will notice that your computer is initially set so that the display turns off after 15 minutes of user inactivity, and the computer goes into Sleep mode after 20 minutes of user inactivity. When going into Sleep mode, the computer also reduces the speed of any active Ethernet network links. To “wake” the computer from Sleep mode, press the Suspend/Resume Button.

Energy saving benefits:

Fujitsu ENERGY STAR qualified mobile PCs use about half as much electricity as standard equipment – saving half in utility costs. But more than that, ENERGY STAR also makes a difference for the environment. Did you know that the average house can be responsible for twice the greenhouse gas emissions as the average car? That's because every time you flip on a light switch, run your dishwasher, or turn on your PC, you use energy, which means more greenhouse gas emissions from power plants. So the more energy we can save through energy efficiency, the more we help to reduce greenhouse gases and the risks of global warming.

To learn more about the important ENERGY STAR program, visit: www.energystar.gov.

To read about how Fujitsu is supporting Sustainable Management along with several other environmental activities, visit the Fujitsu Corporate Citizenship page at:

<http://www.computers.us.fujitsu.com/www/content/aboutus/environmental/environment.php>



Contents

Preface

About This Guide	14
Conventions Used in the Guide	14
Fujitsu Contact Information	15

Chapter 1 Getting to Know Your Tablet PC

Overview	17
Locating the Connectors and Controls	18
Front Features:	19
Back Features:	20
Top Features:	22
Left-Side Features:	24
Right-Side Features:	26
Status Display	27
Application, Navigation, and Security Buttons	30
Application Buttons	30
Navigation Buttons	33
Tertiary Functions of Application and Navigation Buttons	34
Security Functions of Application Buttons	36
Setting up the Security Panel	36

Using Your Security Panel	39
Precautions	40
Uninstalling the Security Panel Application	40
Reinstalling the Security Panel Application	41
Installing Click Me!	42
Fujitsu Driver Update Utility	43

Connectors and Peripheral Interfaces. 43

Chapter 7 Using the Stylistic ST6000 Series Tablet PC

System States 46

Proper Tablet PC Orientations	49
---	----

Starting the Tablet PC 49

Powering Up	49
Booting the First Time	50
Shutting Down	53
Suspending System Operation	53
Resuming Operation	56

Productivity Applications and Utilities 57

Using the Shock Sensor Utility	58
Display Profiles	60
Adjusting the Display Brightness	60

Using the Pen 62

Calibrating the Pen	64
Installing a Pen Tether	64
.	65
Replacing the Pen Tip	65

User-Installable Features 66

Lithium ion Battery	66
-------------------------------	----

Operation of the Bridge Battery	68
Memory Stick/SD Card Slot	69
PC Card Slot	71
Removing and Installing Memory	72

Chapter 2 Care and Maintenance

Caring for your Tablet PC	74
Precautions	75
Protecting the Display Screen	75
Storing the Tablet PC	77
Avoiding Overheating	78
Cleaning the Display Screen	78
Troubleshooting	79
Restoring the Included Software TBD - NEW PROCEDURE?	81
BOOT Priority Change	83
Automatically Downloading Driver Updates	84

Chapter 3 System Specifications

Specifications	86
Configuration Label	86
Microprocessor	87
Chipset	87
Memory	87
Video	87
Audio	88
Mass Storage Device Options	89
Communications	89
Security Features	89
Device Ports	90
Power	91

Dimensions and Weight	91
Environmental Requirements	91
Popular Accessories	91
Included Software	92
Learning About Your Software	92

Regulatory Information 95

Notice	95
FCC NOTICES	95
DOC (INDUSTRY CANADA) NOTICES	97

Appendix A: WLAN User’s Guide

FCC Regulatory Information	100
Regulatory Notes and Statements	100

Before Using the Optional Wireless LAN 103

Wireless LAN Device Covered by this Document	103
Characteristics of the WLAN Device	103
Wireless LAN Modes Using this Device	104
Deactivating/Disconnecting the WLAN Device	106
Deactivation Using the Wireless On/Off Switch	107
Disconnection Using the Icon in the Taskbar	107
Activating the WLAN Device	107

Configuring the Wireless LAN 108

Configuring the WLAN Using Windows Vista	108
Configuring the WLAN Using Windows XP	109
Connection to the network	109

Troubleshooting the WLAN 110

Troubleshooting	110
---------------------------	-----

WLAN Specifications 112

Specifications	112
--------------------------	-----

Using the Bluetooth Device..... 114

What is Bluetooth? 114

Where to Find Information About Bluetooth 114

Appendix B: Fingerprint Sensor Device

Introducing the Fingerprint Sensor Device 116

Getting Started 117

Installing OmniPass 117

User Enrollment 120

Using OmniPass 123

Configuring OmniPass 128

OmniPass Control Center 130

Troubleshooting 133

Index



Preface

About This Guide

The Stylistic[®] ST6000 Series Tablet PC is a high-performance, pen-based computer that has been designed to support Microsoft[®] Windows[®] Vista Business or Windows XP Tablet PC Edition.

This manual explains how to operate your Stylistic ST6000 Series Tablet PC hardware and built-in system software.

The Stylistic ST6000 Series Tablet PC is a completely self-contained unit with an active-matrix (TFT) color indoor-outdoor LCD display and an active digitizer. It has a powerful interface that enables it to support a variety of optional features.

Conventions Used in the Guide

Keyboard keys appear in brackets. Example: [Fn], [F1], [ESC], [ENTER] and [CTRL].

Pages with additional information about a specific topic are cross-referenced within the text. Example: (See page xx.)

On screen buttons or menu items appear in bold. Example: Click **OK** to restart your Tablet PC.



THE INFORMATION ICON HIGHLIGHTS INFORMATION THAT WILL ENHANCE YOUR UNDERSTANDING OF THE SUBJECT MATERIAL.



THE CAUTION ICON HIGHLIGHTS INFORMATION THAT IS IMPORTANT TO THE SAFE OPERATION OF YOUR COMPUTER, OR TO THE INTEGRITY OF YOUR FILES. PLEASE READ ALL CAUTION INFORMATION CAREFULLY.



THE WARNING ICON HIGHLIGHTS INFORMATION THAT CAN BE HAZARDOUS TO EITHER YOU, YOUR TABLET PC, OR YOUR FILES. PLEASE READ ALL WARNING INFORMATION CAREFULLY.

Fujitsu Contact Information

Service and Support

You can contact Fujitsu Service and Support in the following ways:

- Toll free: 1-800-8Fujitsu (1-800-838-5487)
- E-mail: 8fujitsu@us.fujitsu.com
- Website: <http://www.computers.us.fujitsu.com/support>

Before you place the call, you should have the following information ready so that the customer support representative can provide you with the fastest possible solution:

- Product name
- Product configuration number
- Product serial number

- Purchase date
- Conditions under which the problem occurred
- Any error messages that have occurred
- Type of device connected, if any

Fujitsu Shopping Online

You can go directly to the online by going to the website at: www.shopfujitsu.com.



YOU MUST HAVE AN ACTIVE INTERNET CONNECTION TO USE THE ONLINE URL LINKS.

Limited Warranty

Your Stylistic ST6010 Tablet PC is backed by a Fujitsu International Limited Warranty. Check the service kit that came with your notebook for the Limited Warranty period and terms and conditions.

Chapter 1

Getting to Know Your Tablet PC

Overview

The Stylistic® ST6000 Series Tablet PC is a high-performance, pen-based computer that has been designed to support Microsoft® Windows® XP Tablet PC Edition 2005 or Windows Vista™ Business. This chapter provides an overview of the Stylistic ST6000 Series Tablet PC and its features.

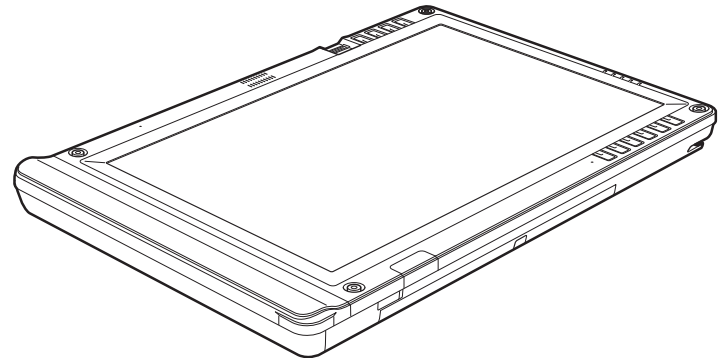

Figure 1. Stylistic ST6010 Tablet PC

Locating the Connectors and Controls

Features and controls that you use to operate the Stylistic ST6000 Series Tablet PC are outlined below and illustrated in Figures 2 through 5. Details on using these features and controls are provided later in this manual.

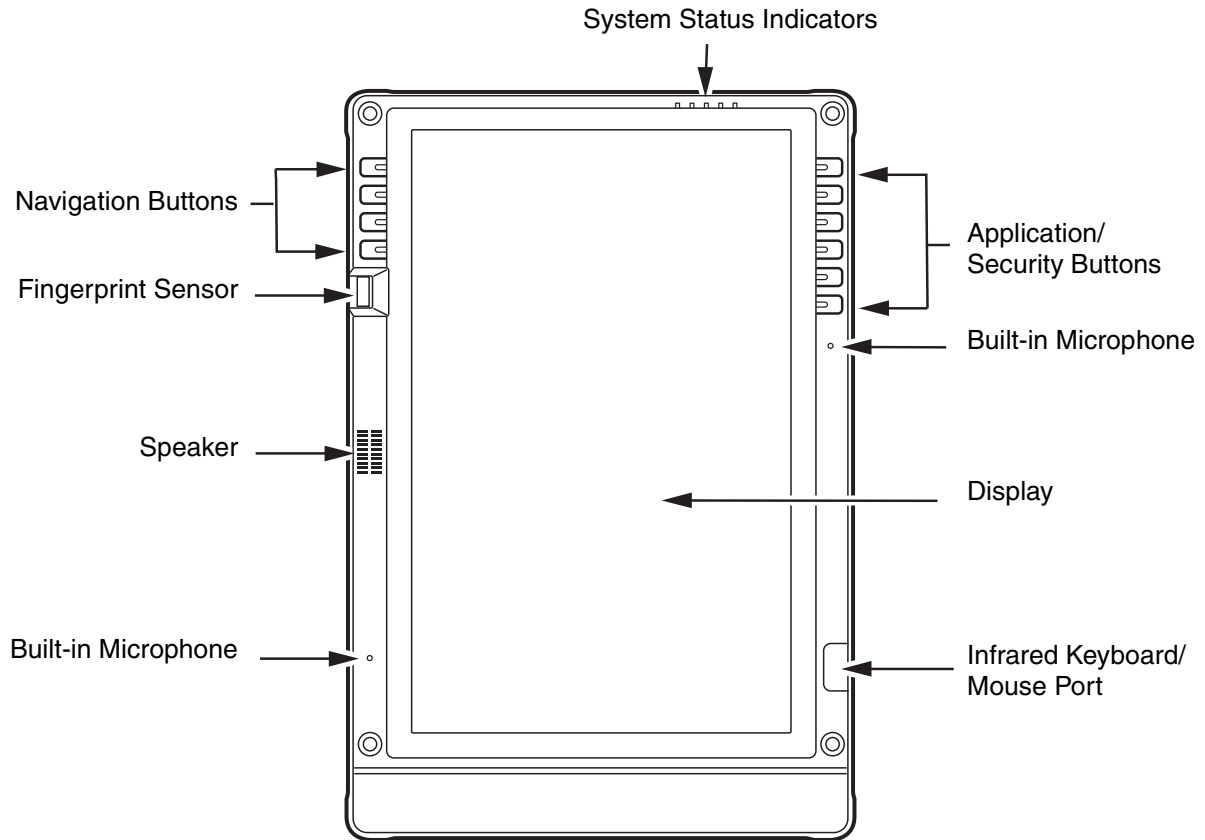

Figure 2. Stylistic ST6000 Series Tablet PC Features (Front View)

Front Features:

System status indicators:

Indicate the operational status of the Tablet PC and hard disk drive, the charge level of the battery, and the security panel. See “Status Display” on page 27.

Application/Security buttons:

Allow you to quickly launch pre-defined applications, utilities, and security features by pressing a button. See “Application, Navigation, and Security Buttons” on page 30.

Built-in Microphones:

The built-in microphones allow you to input mono audio.

Infrared keyboard/mouse ports:

The infrared ports are used for communicating with a proprietary infrared keyboard or mouse.†

Speaker:

Allows you to listen to audio files.

Fingerprint Swipe Sensor:

The optional fingerprint swipe sensor allows you to start your system by swiping your finger over the sensor. See “Introducing the Fingerprint Sensor Device” on page 116.

Navigation buttons:

The navigation buttons allow you to move: Page Up/Page Down, Tab Right/Tab Left, Cursor Up/Cursor Down, and Cursor Right/Cursor Left. See “Navigation Buttons” on page 33.

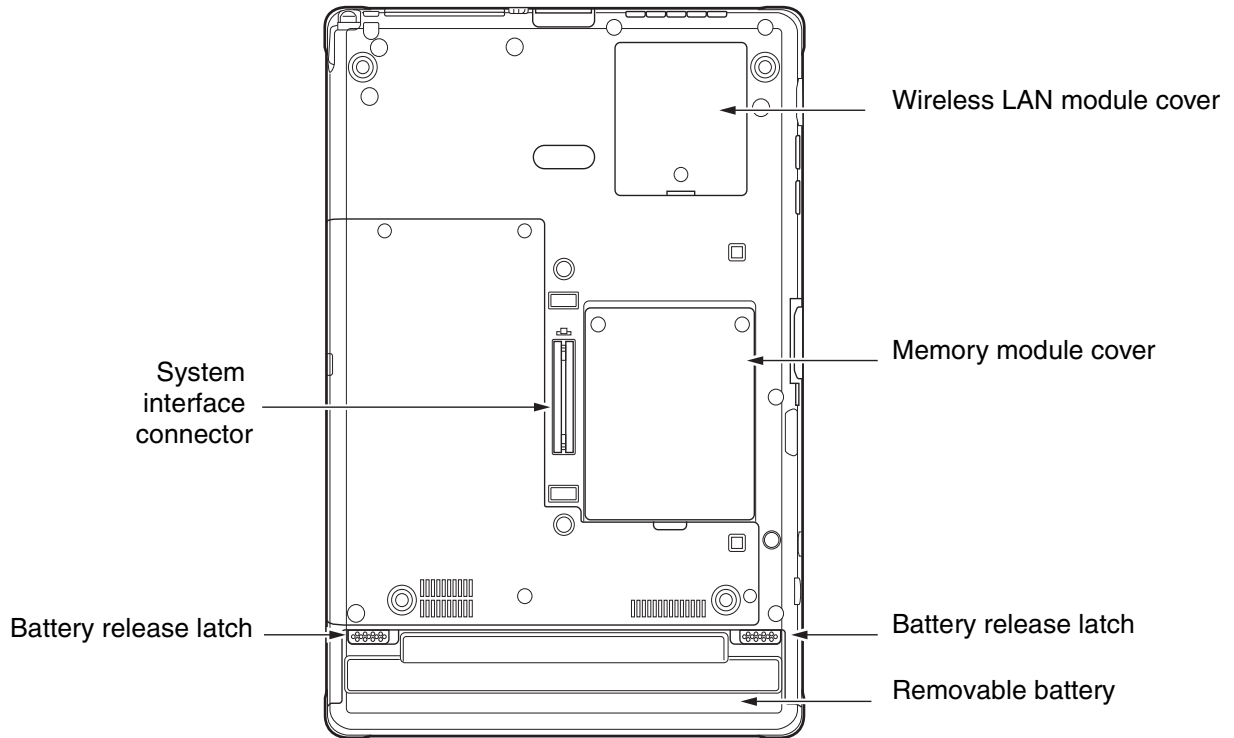

Figure 3. Stylistic ST6000 Series Tablet PC Features (Back View)

Back Features:

Wireless LAN module cover:

Provides protection for the optional wireless LAN radio. See “Configuring the Wireless LAN” on page 108.

Memory module cover:

Removable cover over the memory modules. See “Removing and Installing Memory” on page 72.

Battery release latch:

Used to release the removable battery.

Removable battery:

Can be removed and replaced with a charged battery. See “Lithium ion Battery” on page 66.

System interface connector:

Allows you to connect the optional Stylistic Tablet Dock.

Tablet Dock latch point:

Allows you to attach the system to an optional Tablet Dock.

Thermal Suede:

The back of the memory module is covered with “thermal suede”. This material should not be removed. It is designed to minimize the heat that the user feels when the system has been operating for an extended period of time.

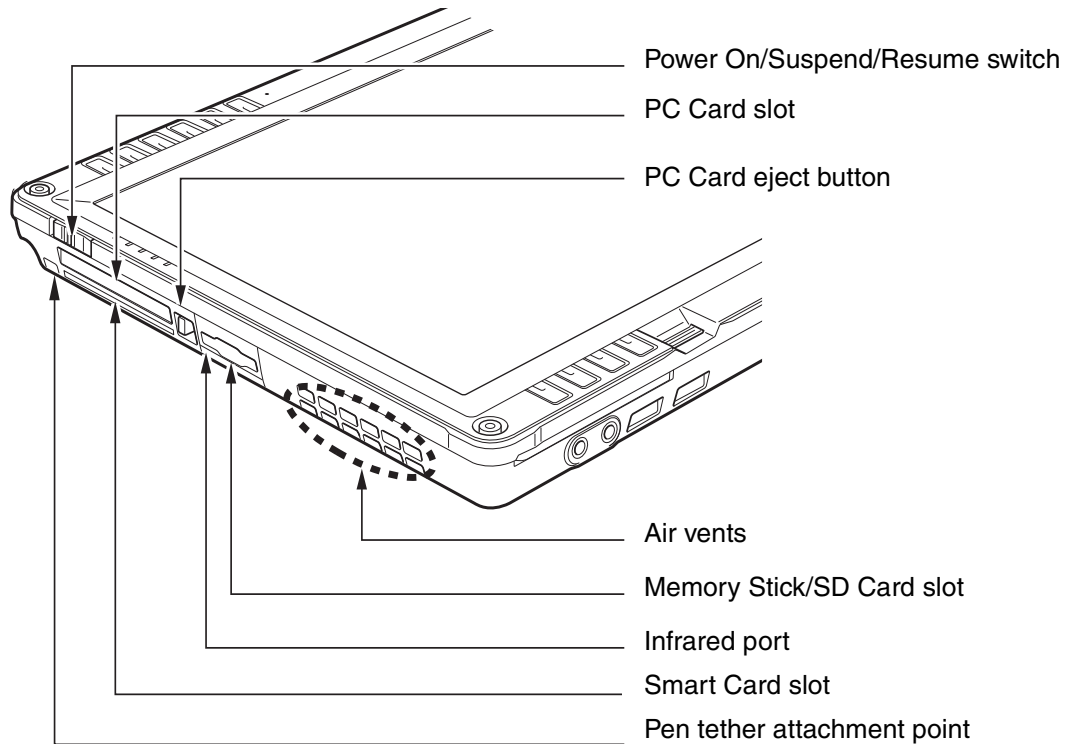

Figure 4. Stylistic ST6000 Series Tablet PC Features (Top View)

Top Features:

Power On/Suspend/Resume switch:

Allows you to turn on, off, sleep, resume, hibernate or wake the Tablet PC in order to optimize battery life. See “Powering Up” on page 49.

PC Card slot:

Allows you to insert a Type I or Type II PCMCIA Card⁺ in the system. See “PC Card Slot” on page 71.

PC Card Eject Button:

The PC Card eject button is used to remove a PC Card from the PC Card slot.

Air flow vents:

Provides secondary cooling for processor.



TO PROTECT YOUR NOTEBOOK FROM DAMAGE AND TO OPTIMIZE SYSTEM PERFORMANCE, BE SURE TO **KEEP ALL AIR VENTS UNOBSTRUCTED, CLEAN, AND CLEAR OF DEBRIS.** THIS MAY REQUIRE PERIODIC CLEANING, DEPENDING UPON THE ENVIRONMENT IN WHICH THE SYSTEM IS USED.

SD Card/Memory Stick Slot:

The Secure Digital (SD) card/Memory Stick slot allows you to insert a flash memory card for data storage. Flash memory cards allow you to transfer data to and from a variety of different digital devices. See “Memory Stick/SD Card Slot” on page 69.

Infrared port:

Provides infrared interface for communication with devices compliant with IrDA Standard Revision 1.1.

Smart Card Slot:

The dedicated Smart Card slot allows you to insert a Smart Card on which you can store such data as medical information or electronic “cash”.

Pen Tether Point:

The pen tether point is used to attach a pen tether to help prevent loss of the pen. See “Installing a Pen Tether” on page 64.

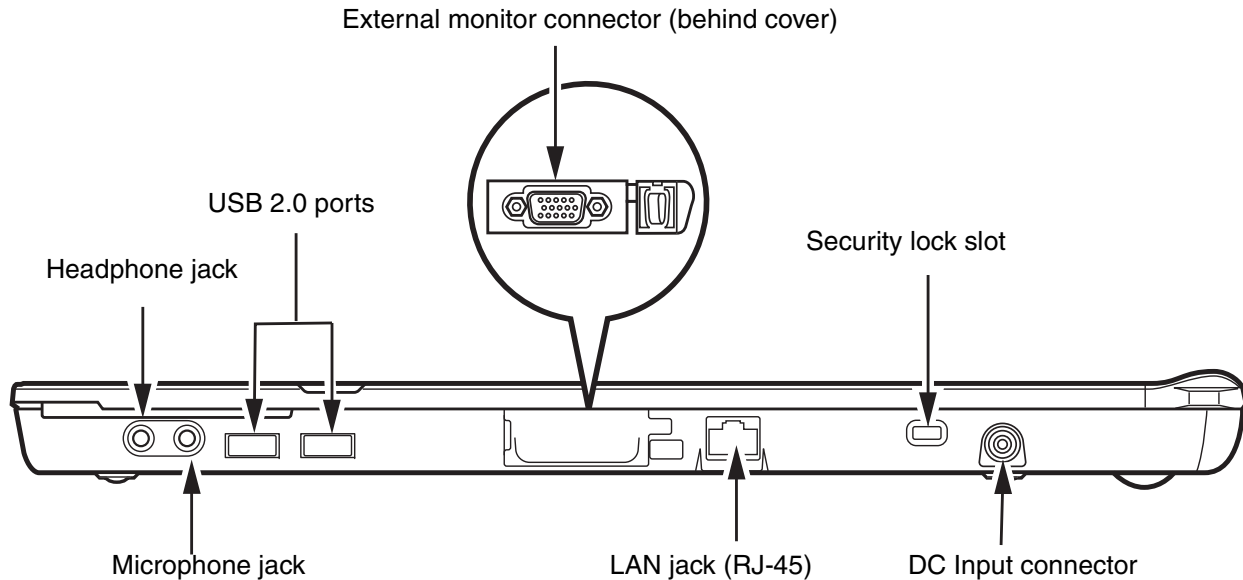

Figure 1-1. Stylistic ST6000 Series Tablet PC Features (Left Side View)

Left-Side Features:

Headphone Jack:

Allows you to connect a set of stereo headphones.

USB 2.0 ports:

Allow you to connect Universal Serial Bus-compliant devices (compliant with USB Standard Revision 2.0) to the Tablet PC. Additional USB ports are located on the optional Tablet Dock.

External Monitor Connector:

The External Monitor connector allows you to connect an external monitor or projector.

Security lock slot:

Allows you to attach a compatible security cable.

DC input connector:

Allows you to connect the AC adapter or auto adapter.

LAN jack:

Allows you to connect a standard RJ-45 connector to the Tablet PC's internal local area network (LAN).

Microphone Jack:

Allows you to connect an external microphone.

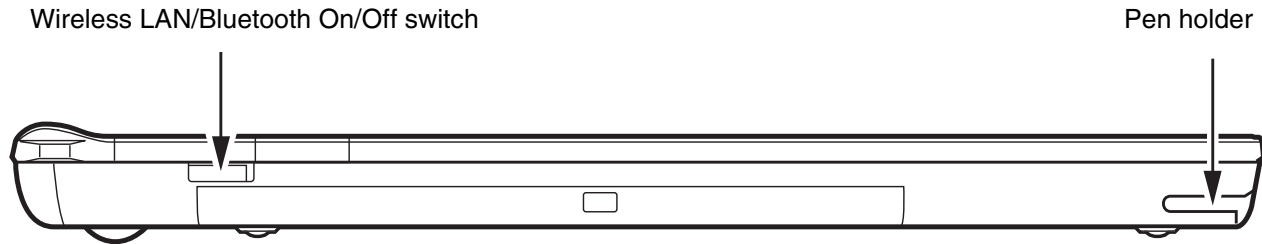

Figure 5. Stylistic ST6000 Series Tablet PC Features (Right Side View)

Right-Side Features:

Wireless LAN/Bluetooth On/Off switch:

For systems with the optional wireless LAN radio or Bluetooth device, this switch toggles the radio on or off. See “Using the Bluetooth Device” on page 114.

Pen holder:

The pen is the main pointing device that you use to execute programs and enter data. A pen holder is built into the Tablet PC to store the pen when not in use.

Status Display

Icons appear under each of the system status LEDs in the status display indicating the status of system functions such as system power and battery charge level. The location of icons in the Status display is shown in Figure 6.

Table 1. explains how the LEDs associated with the individual icons are displayed, and describes what the variations of that display indicate. (If an icon is not displayed, it indicates that the related system function is off or inactive.)

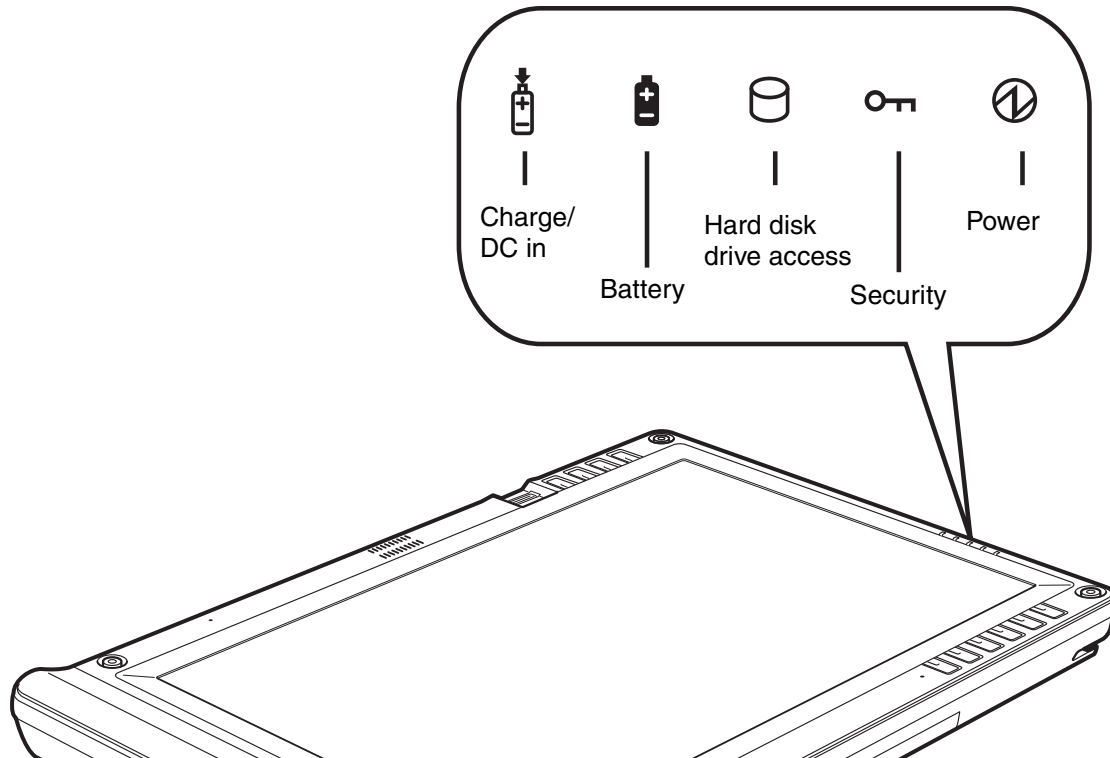



Figure 6. Status Display Icons

In the following table, a “blinking” LED flashes at the rate of once per second; an LED that is “blinking, slow” flashes at the rate of one second on, five seconds off.

Icon	Mode/State	LED State	Remarks
Charge/DC In 	<ul style="list-style-type: none"> • On State • Idle Mode • Sleep • Hibernate • Off State 	Amber	AC adapter and battery are available and system is charging.
		Green	<ul style="list-style-type: none"> • AC adapter and battery are available and system is not charging (battery fully charged). • AC adapter is available but battery is not present.
		Amber, blinking	AC adapter and battery are available and waiting to charge (battery is out of thermal range).
		Off	AC adapter is not available.
Battery 	<ul style="list-style-type: none"> • On State • Idle Mode 	Green, continuous	Battery charge is between 50%-100%
		Amber, continuous	Battery charge is between 13%-49%
		Red, continuous	Battery charge is between 0%-12%
		Red, blinking	There is a battery error.
	<ul style="list-style-type: none"> • Sleep, without AC adapter • Sleep with AC adapter 	Green, blinking slow	Battery charge is between 50%-100%.
		Amber, blinking slow	Battery charge is between 13%-49%.
		Red, blinking slow	Battery charge is between 0%-12%.
	<ul style="list-style-type: none"> • Hibernate, with AC adapter • Off State 	Off	Battery is not installed, or system is off or in Hibernate mode.

In the following table, a “blinking” LED flashes at the rate of once per second; an LED that is “blinking, slow” flashes at the rate of one second on, five seconds off.



Icon	Mode/State	LED State	Remarks
HDD Access 	<ul style="list-style-type: none"> • On State (or flashing) • Idle Mode 	Green	Displayed when hard disk drive is accessed.
	<ul style="list-style-type: none"> • Sleep • Hibernate • Off State 	Off	Hard disk drive is not being accessed.
Security 	<ul style="list-style-type: none"> • On State 	Green, continuous (until password is entered)	The Security Indicator lights (if a password was set) when the system resumes from Off or Sleep modes. You must enter the password that was set in the Security Panel before your system will resume operation. See “Security Functions of Application Buttons” on page 36.
Power 	<ul style="list-style-type: none"> • On State • Idle Mode 	Green, continuous	The system is powered on and ready for use.
	<ul style="list-style-type: none"> • Sleep 	Green, blinking	The system has suspended and saved active settings to RAM.
	<ul style="list-style-type: none"> • Off State • Hibernate 	Off	The system has suspended and saved settings and data to the hard disk drive.

Table 1. System Status Indicators

Application, Navigation, and Security Buttons

Application Buttons

The six application buttons are located on the upper right-hand side of a vertically-oriented system. Five of the buttons have secondary functions. The secondary functions are activated by pressing the Function (Fn) button while pressing the application button.

The buttons also have separate tertiary functions that can be used while the system is booting up. For more information about the tertiary functions, refer to Table 4 on page 35.

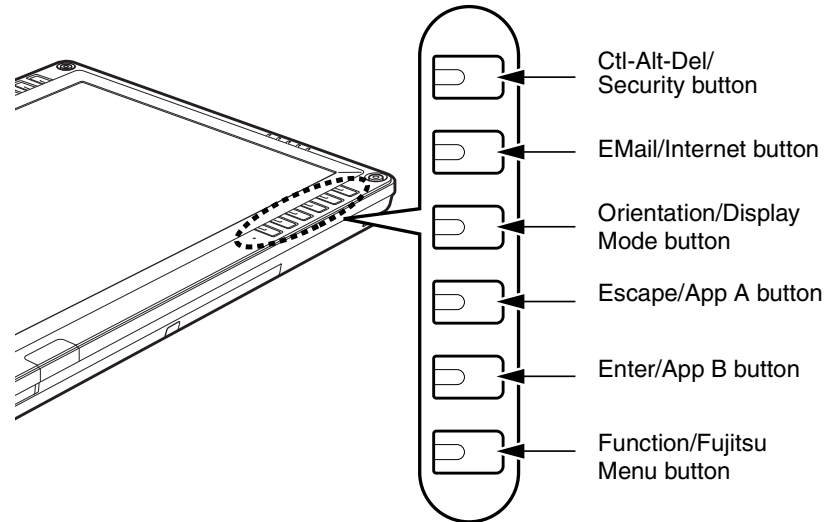







Figure 7. Application buttons



CTL-ALT-DEL IS THE ONLY APPLICATION BUTTON THAT CAN BE USED WHILE THE SYSTEM IS LOGGING ON OR WHEN THE SYSTEM IS LOCKED (I.E., WHEN YOU HAVE THE LOGON OR COMPUTER LOCKED WINDOW SHOWING ON YOUR DESKTOP).

Button Icon and Name Primary)	Tablet Icon (Fn + Button) (Secondary)	Description
 <p>Ctl-Alt-Del Button</p>	 <p>Security Button</p>	<p>Pressing the Ctl-Alt-Del button for approximately one second allows you to log on after boot or after resuming from power management. Holding the button down for approximately two seconds causes it to act as if Ctl-Alt-Del had actually been entered from a keyboard.</p> <p>Security Button: All five buttons are used when implementing security functions. Four of the buttons are used to enter the password, and the fifth is used as an Enter button. See “Security Functions of Application Buttons” on page 36.</p>
 <p>E-Mail Button</p>	 <p>Internet Button</p>	<p>When you press the E-Mail button, you automatically launch Microsoft Outlook Express, where you can read, create, and send emails.</p> <p>When you press the Fn + E-Mail buttons at the same time, you automatically launch the Web browser. The default page to which you go is the Fujitsu home page. If you would like to change your home page, go to the Control Panel-> Internet Options. Select the General tab and enter the starting address you would like to use.</p>
 <p>Orientation Button</p>	 <p>Display Mode Button</p>	<p>When you press the Orientation button, the system screen orientation changes from portrait (vertical) to landscape (horizontal) or from landscape to portrait. When you would like to use the Tablet PC as an eBook, for example, you would use the portrait orientation, when accessing spreadsheets, you would more typically use a landscape orientation.</p> <p>When you press the Fn + Orientation buttons at the same time*, the display output will switch between internal, external, and simultaneous display.</p>

Button Icon and Name Primary)	Tablet Icon (Fn + Button) (Secondary)	Description
<p>ESC</p> <p>Escape Button</p>	<p>A</p> <p>Application A Button</p>	<p>The Escape application button acts the same way as an Escape key on a keyboard.</p> <p>When you press the Fn + Esc buttons at the same time*, they act to invoke a pre-determined application or generate a combination keystroke, as assigned in the Tablet Button Settings utility. (You can change the settings in Control Panel -> Tablet Button Settings).</p> <p>By default, pressing the Fn + Esc combination acts the same as if you had pressed Ctrl + Esc on a keyboard: the Start menu is launched.</p>
<p>ENT</p> <p>Enter Button</p>	<p>B</p> <p>Application B Button</p>	<p>The Enter application button acts the same way as an Enter key on a keyboard.</p> <p>Pressing the Fn + Ent buttons at the same time*, acts to invoke a pre-determined application or keystroke combination, as assigned in the Tablet Button Settings utility. (You can change the settings in Control Panel -> Tablet Button Settings).</p> <p>By default, pressing the Fn + Ent combination acts the same as if you had pressed Alt on a keyboard: it selects a main menu in the typical Windows application.</p>
<p>Fn</p> <p>Function Button</p>	<p>Fujitsu Menu Utility</p>	<p>The Function button works in conjunction with the other application buttons to provide additional functionality for the buttons. Refer to specific details above.*</p> <p>Pressing the Fn button twice in succession (within the “sticky” time*), causes the Fujitsu menu to appear on your screen, allowing you to modify certain system settings.</p>

Table 2. Application Buttons - Primary and Secondary Functions

- * The **Fn** button has a handy “sticky” feature that allows you to press two buttons in immediate succession, rather than at exactly the same time. After pressing the **Fn** button, you have a short time (2 to 3 seconds) to press the second button.

Navigation Buttons

The four navigation buttons are located on the upper left-hand side of a vertically-oriented system.

The buttons have dual functions. The secondary functions are activated by pressing the Function (Fn) button while pressing the application button*.

The buttons also have separate tertiary functions that can be used while the system is booting up. For more information about the tertiary functions, refer to Table 4 on page 35.

* The **Fn** button has a handy “sticky” feature that allows you to press two buttons in immediate succession, rather than at exactly the same time. After pressing the **Fn** button, you have a short time (2 to 3 seconds) to press the second button.

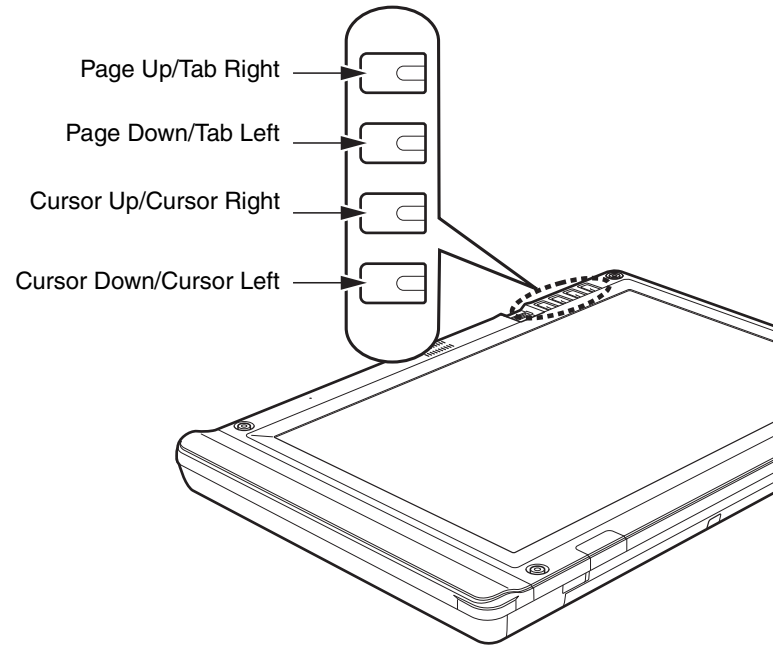

Figure 8. Navigation buttons

Button/Icon	Purpose (when pressed alone) ("Primary" function)	Description
▲ ▶	When Page Up is pressed, you will scroll up one page.	When pressed with the Function (Fn) button*, this button allows you to tab right.
▼ ◀	When Page Down is pressed, you will scroll down one page.	When pressed with the Function (Fn) button*, the Down button allows you to tab left.



Button/Icon	Purpose (when pressed alone) ("Primary" function)	Description
	When Cursor Up portion is pressed, the cursor will move up.	When pressed with the Function (Fn) button*, the Cursor Up button will move the cursor to the right.
	When Cursor Down portion is pressed, the cursor will move down.	When pressed with the Function (Fn) button*, the Cursor Down button will move the cursor to the left.



Table 3. Navigation Buttons

Tertiary Functions of Application and Navigation Buttons

While you are booting up your system, the Application Buttons and Navigation buttons can be used for entering and navigating through the Basic Input-Output System (BIOS), and for invoking the Advanced Options Menu, where you can enter different modes (such as Safe Mode).

The BIOS is a program and a set of parameters that are stored in ROM, which tests and operates your Tablet PC from when you turn it on until it loads your installed operating system from disk. Information from the BIOS is transferred to the operating system to provide it with information on the configuration and status of the hardware.

The system is booting up while the Fujitsu logo is displayed immediately after turning on the system. The table below indicates how the buttons act while the system is booting up and while you are in the BIOS..

Buttons/icons	Purpose (when pressed while the system is booting up)
 Ctl-Alt-Del Button	Pressing the Ctl-Alt-Del button while the system is booting up takes you into BIOS setup. This is the same as if you had tapped [F2] on a keyboard.
 E-Mail Button	Pressing the E-Mail button while the system is booting up opens the Boot Options menu. This is the same as if you had tapped [F12] on a keyboard.





 Orientation Button	Pressing the Orientation button while the BIOS setup screen is open causes the selected item (if applicable) to change to the next item. Pressing this is the same as tapping the spacebar on a keyboard.
ESC Escape Button	Pressing the Esc button while the BIOS is open acts to escape from the BIOS. This is the same as if you had tapped [Esc] on a keyboard.
ENT Enter Button	Pressing the Ent button while the BIOS is open acts the same as the [Ent] button on a keyboard.
Fn Function Button	Pressing the Fn button while the system is displaying the operating system boot menu, opens the Advanced Operating System Options menu. This menu allows you to enter different operating system modes (such as Safe Mode). Pressing this button is the same as if you had tapped [F8] on a keyboard.
 Cursor Up	Pressing the top navigation button while the BIOS setup screen is open causes the cursor in the BIOS setup screen to move up. This is the same as if you had tapped Arrow Up on a keyboard. This feature is also functional in the operating system boot menu.
 Cursor Down	Pressing the second navigation button from the top while the BIOS setup screen is open causes the cursor in the BIOS setup screen to move down. This is the same as if you had tapped Arrow Down on a keyboard. This feature is also functional in the operating system boot menu.
 Next Menu	Pressing the second navigation button from the bottom while the BIOS setup screen is open causes the BIOS setup screen to jump to the next menu. This is the same as if you had tapped Arrow Right on a keyboard.
 Previous menu	Pressing the bottom navigation button while the BIOS setup screen is open causes the BIOS setup screen to jump to the previous menu. This is the same as if you had tapped Arrow Left on a keyboard.

Table 4. Tertiary Functions of Application and Navigation Buttons

Security Functions of Application Buttons

Five buttons are used when implementing security functions. Four of the buttons are used to enter the password, and the fifth is used as an Enter button. Instructions for using the security feature follow the table.



Button Icons	Security Icons	Security Purpose
 Ctl-Alt-Del Button		Security Enter Button
 EMail Button	1	Security Button 1
 Orientation Button	2	Security Button 2
ESC Escape Button	3	Security Button 3
ENT Enter Button	4	Security Button 4

Table 5. Security Functions of Application Buttons

Setting up the Security Panel

When you receive your Tablet PC, the security panel application is pre-installed without any passwords. The following sections provide detailed information on your security panel, how to set, change or remove passwords.

Numbered Buttons

Use these buttons to enter your password.(Figure 5)

Enter Button

After entering the button strokes, push this button to enter the password into the Tablet PC. (Figure 5)

Passwords

The user and supervisor password may be set on this Tablet PC. A supervisor password is typically the same for all Tablet PC's and notebooks in a work group, office, or company to allow for system management. Individual computers in a group environment should not use a common password. A password consists of one to five button strokes plus the enter button. A valid stroke consists of pushing one or up to four buttons simultaneously.

The following are examples of valid button strokes:

- Pushing [4] by itself
- Pushing [2] and [3] at the same time
- Pushing [1], [2], and [4] at the same time
- Pushing [1], [2], [3], and [4] at the same time

The following are valid passwords. The numbers within braces ({ }) are button strokes using more than one button.

- {[2]+[3]}, [1], [Enter]
- [4], [enter]
- {[1]+[3]}, {[2]+[3]+[4]}, [1], [4], [2], [Enter]

Setting Passwords

When shipped from the factory, no passwords are set. You have a choice of having no password or setting a supervisor and user password. You must set the supervisor password before the user password.



- THE PURPOSE OF SUPERVISOR PASSWORD IS TO BE ABLE TO BYPASS THE USER PASSWORD IN CASE THE USER PASSWORD IS FORGOTTEN. THE SUPERVISOR PASSWORD ALONE WILL NOT LOCK THE SYSTEM.
- YOU MUST SET THE SUPERVISOR **AND** USER PASSWORDS FOR THE SECURITY PANEL TO WORK.

Setting Supervisor Password

You must have set a supervisor password before setting any user passwords. The supervisor password can bypass the user password.

- 1 Go to the **Start** menu.
- 2 Click on **Run**.
- 3 Type in:
C:\Program Files\Fujitsu\Security Panel Application\Supervisor\FJSECS.EXE, then press [Enter]
- 4 Follow the on-screen instructions to set the Supervisor password.

Setting User Password

- 1 Go to the **Start** menu.
- 2 Click on **All Programs**.
- 3 Click on **Security Panel Application -> Security Panel Application**.
- 4 Follow the on-screen instructions to set the user password.



YOU MAY CHANGE OR REMOVE THE SUPERVISOR OR USER PASSWORD BY REPEATING THE STEPS DEFINED ABOVE.

Using Your Security Panel

The security lock feature is in effect both when the system resumes from Off, Sleep, or Hibernation state. You always need to push the Security Panel buttons to input the user password. Your system will not begin the boot sequence until you enter your supervisor/user password.

From Off State

- 1 Turn on your system.
- 2 When the Security Indicator flashes, enter the password and press Enter button.
For example, if the password is 22222, first press Button 2 five times and press the Enter button. The Tablet PC will boot to normal operation.

From Sleep/Hibernation State

- 1 Press your Suspend/Resume button.
- 2 When the Security Indicator flashes, enter the password and press Enter button. The Tablet PC should resume normal operation.

Incorrect Password Entry

If an invalid supervisor or user password is entered three times in succession, the system will “beep” for about one minute. If a valid password is entered within a minute (while system beeps), the beeping will stop and the Tablet PC will resume normal operation. If no password is entered or an invalid password is entered while the system beeps, the system will return to its previous locked state (sleep or off) and the Security Indicator will go off. To reactivate the Tablet PC after a password failure, you must press the Suspend/Resume button, then enter a correct password.



REMEMBER THE USER PASSWORD YOU SPECIFIED ON THE SECURITY PANEL APPLICATION. IF YOU FORGET THE PASSWORD YOU WILL NOT BE ABLE TO USE YOUR COMPUTER. THE SUPERVISOR PASSWORD CAN OVERRIDE THE USER PASSWORD.

Precautions

Low Battery Operations

If your Tablet PC has a low battery, pushing the suspend/resume button does not unlock the Tablet PC. To resume normal operation, first attach a power supply to the system. Then you may unlock the Tablet PC.

Uninstalling the Security Panel Application

You have two options when uninstalling the security panel application:

- Remove passwords and uninstall the security panel application software. This will disable all security features.
- Uninstall the security panel application with password still active. This will not allow any changes to the password.

Uninstalling the Security Panel Application Software

Remove passwords when User wants no password protection whatsoever and doesn't want to give anybody the utility to set a password on their computer. In this case, if passwords (supervisor, user, or both) are set, the passwords must first be cleared BEFORE removing the application. To clear passwords, follow same procedure in SETTING PASSWORD CODES except this time, select REMOVE, enter current password then click **Next**. When asked to confirm select **Yes**.

Removing Security Panel Application with Passwords Still Active

Using this feature will not allow any changes to the password.



REMOVING THE APPLICATIONS DOES NOT REMOVE THE PASSWORD. IT SIMPLY REMOVES THE UTILITY TO CHANGE/ADD/REMOVE PASSWORDS. TO CHANGE YOUR PASSWORD YOU MUST REINSTALL THE APPLICATION.

User:

- 1 Go to **Start Menu**. Click on **Control Panel**.
- 2 Open **Add or Remove Programs** (In Vista: **Programs and Features**) in the Control Panel.
- 3 Select the **Security Panel Application** (In Vista: **Security Panel**) in the list, and click **Add/Remove**.
- 4 When the Confirm File Deletion box appears, click **Yes**.

Supervisor:

- 1 Go to **Start Menu**, Click on **Control Panel**.
- 2 Open **Add or Remove Programs** (In Vista: **Programs and Features**) in the Control Panel.
- 3 Select the **Security Panel Application for Supervisor** (In Vista: **Security Panel for Supervisor**) in the list, and click **Add/Remove** (In Vista: **Uninstall**).
- 4 When the Confirm File Deletion box appears, click **Yes**.

Reinstalling the Security Panel Application

To reinstall supervisor or user security application, you will need your Drivers and Applications CD. The **Utilities\Security Panel Application** folder contains two separate folders: **Supervisor** and **User**. The setup files for supervisor and user security applications are contained in those folders.

- 1 Go to the **Utilities\Security Panel Application\Supervisor** folder on the CD and double-click the **setup.exe** file. The Installing Security Panel Application window will appear. Follow the instructions on the screen.
- 2 Go to the **Utilities\Security Panel Application\User** folder on the CD and double-click the **setup.exe** file. The Installing Security Panel Application window will appear. Follow the instructions on the screen.

Supervisor and user passwords can be set via Windows software using the FJSECS.exe and FJSECU.exe files, respectively. FJSECU.exe for the user password cannot run without first setting a supervisor password. You need to run FJSECS.exe first to set the supervisor password. Follow instructions under Setting Passwords on page 38.

If you forget both passwords, please contact Fujitsu Computer Systems Corporation Service and Support at 1-800-8Fujitsu (1-800-838-5487). Fujitsu Computer Systems Corporation charges a service fee for unlocking a password-restricted Tablet PC. When calling please have a valid credit card and provide proof of ownership. You will then be given instructions on where to ship your Tablet PC.

Installing Click Me!



BEFORE INSTALLING THE CLICKME! UTILITY, BE SURE THE WIRELESS LAN SWITCH IS TURNED ON.

Windows Vista Systems

The first time you boot up your system, you will see a “Primary Settings for the PC” window. This window explains the installations which will be performed by the Click Me! utility. If you click [Execute], Click Me! will begin installing. If after clicking the button you receive a “User Account Control” window, you will be asked for your permission to continue. Click [Yes] to continue. If you cancel the operation, the Click Me! icon will appear on your desktop for later installation.

Windows XP Systems

The first time you boot up your system, you will see an icon called Click Me! in the Start menu. **We highly recommend that you install the ClickMe! utility the first time you boot up.** When you click the Click Me! icon, your system will automatically build the icon tray in the bottom right of the screen. These icons provide links to utilities that you will frequently access., such as wireless LAN software provided by the wireless LAN manufacturer.



THERE MAY BE ADDITIONAL THIRD-PARTY APPLICATIONS THAT ARE NOT INSTALLED BY THE CLICKME! UTILITY. FOR MORE INFORMATION, REFER TO YOUR GETTING STARTED GUIDE.







Fujitsu Driver Update Utility







Your system has a convenient tool called the Fujitsu Driver Update (FDU) utility. With FDU, you can choose to automatically or manually go to the Fujitsu site to check for new updates for your system. For more information about the FDU utility, refer to “Fujitsu Driver Update Utility” on page 43.

Connectors and Peripheral Interfaces

Connectors and peripheral interfaces on the Stylistic ST6000 Series Tablet PC allow the connection of a variety of devices. Specific locations are illustrated in Figures 1-2 through 1-5.

Table 6 provides a description of each peripheral connector on the Stylistic ST6000 Series Tablet PC. Each of the illustrated icons is either molded into or printed on the Tablet PC chassis.

Connector/Peripheral	Tablet PC Icon	Purpose
DC input connector		Connect an external power source such as the AC adapter or auto/airline adapter.
USB Port		Connect Universal Serial Bus 2.0 compliant devices to the Tablet PC.
PCMCIA Card slot		Insert a Type I or Type II PC Card.
SD Card/Memory Stick slot		Insert a Secure Digital (SD) Card or a Memory Stick.
Microphone jack		Connect an external microphone. The internal microphone is disabled when you plug in an external microphone.
Headphone jack		Connect stereo headphones or powered external speakers. The internal speaker is disabled when you plug in external headphones or powered speakers.

Connector/Peripheral	Tablet PC Icon	Purpose
IrDA/FIR port		<p>An infrared transceiver built into the Tablet PC allows you to communicate with other devices that are compliant with the IrDA Standard Rev. 1.1. Effective range for infrared communication is about 3 feet, and within 15 degrees off center. A clear line-of-sight path must exist between the IrDA port on the Tablet PC and the IrDA transceiver on the other device.</p>
Tablet Dock port		<p>Connect the Stylistic ST6000 Series Tablet Dock or other approved docking device. Refer to documentation accompanying the docking device for more information.</p>
Infrared keyboard/mouse port		<p>An infrared receiver built into the Tablet PC allows you to communicate with a Fujitsu wireless infrared keyboard or mouse. The keyboard infrared port works optimally when it is placed between 10 to 30 cm (approximately 4 in. to 12 in.) from the keyboard infrared port (which is located on the bottom edge of the Tablet PC). Ensure there is a clear line-of-sight path between the infrared receiver on the Tablet PC and the infrared transmitter on the keyboard or mouse. Note that an infrared keyboard or mouse works best when the system is in landscape orientation.</p>
Lock slot		<p>The security slot allows you to secure the Tablet PC using compatible locking devices.</p>
Suspend/Resume button		<p>The Suspend/Resume/Power On button allows you to suspend Tablet PC activity without powering off, resume your Tablet PC from sleep mode, and power on the system when it has been shut down from Windows.</p>
Page Up/Page Down		<p>The Page Up/Page Down button allows you to navigate quickly from page to page without scrolling.</p>
Local Area Network (LAN)		<p>The LAN (RJ-45) jack is used to connect the internal 10/100/1000* Base-T/Tx Ethernet to a Local Area Network (LAN) in your office or home, or broadband devices such as a cable modem, DSL, or satellite internet.</p> <p>*1000 Mbps, commonly referred to as Gigabit Ethernet.</p>



Connector/Peripheral	Tablet PC Icon	Purpose
Battery Release Latch		The battery release latch allows you to remove the battery from your system for storage or replacement.
Wireless LAN/Bluetooth On-Off Switch		The wireless LAN/Bluetooth switch allows you to turn power to the optional wireless LAN or Bluetooth devices on and off.

Table 6. Connectors and Interfaces

Chapter 7

Using the Stylistic ST6000 Series Tablet PC

This chapter covers the fundamental concepts, basic system operation and use, and system functions of the Stylistic ST6000 Series Tablet PC. You should familiarize yourself with this information before you attempt to operate the system.



PRIOR TO USING YOUR SYSTEM, BE SURE TO **FULLY CHARGE** THE BATTERY IF YOU PLAN TO RUN ON BATTERY POWER. FAILURE TO DO SO MAY RESULT IN ERRATIC PERFORMANCE.

System States

Before you begin using your Tablet PC, review the different system states (or modes) that the system can use. Being familiar with these states will help you determine whether it is appropriate to turn on, resume, sleep, hibernate or shut down the system when you begin or end a session. System behavior for each system state is described briefly in the following, with each system state listed in decreasing order of power usage:

- **On state:** The system is running and the display screen is on.

- **Idle state:** Some system functions are regulated or turned off to conserve power. The display screen may be turned off. The system returns to the On state when pen activity or other input is detected.
- **Sleep mode (S3):** System operation is suspended. Most system functions are turned off to conserve power. Power to memory is on, maintaining data in programs that were running before system operation was suspended. The system does not respond to the pen or other input when in Sleep mode. Refer to the “Resuming System Operation” section later in this chapter for information on returning the system to the On state.
- **Hibernate mode (S4):** System operation is suspended. All system functions are turned off to conserve power. Active data in programs that were running before suspending system operation is stored on the hard disk drive. The system does not respond to the pen or other input. Refer to the “Resuming System Operation” section later in this chapter for information on returning the system to the On state.
- **Off state:** All system functions are turned off to conserve power. The system does not respond to the pen or other input. The system boots at the next system power-on.



THE SYSTEM CONSUMES THE SAME AMOUNT OF POWER WHETHER IT IS IN HIBERNATE MODE OR THE OFF STATE.

Your system may be configured to enter some of these states automatically after a period of inactivity to conserve battery power.

Icon Appearance	Current State	To Change State *
Power icon displayed continuously	On State or Idle State	To enter Off state, shut down the system using the Start menu on your system.
		To enter Sleep or Hibernate [†] state, suspend system operation using either a hardware or software suspend.

Icon Appearance	Current State	To Change State *
Power icon blinking	Sleep [†]	To enter the On state, resume system operation by pressing the Suspend/Resume button.
		To enter the Off state, resume system by pressing the Suspend/Resume button, then shut down your system.
Power icon not displayed	Off State, or, Hibernate	To enter the On state, start your system, or resume system operation by pressing the Suspend/Resume button.

Table 1. Changing System States

* Information in Table 1 is supplied to help you understand which system states your system can enter from the current system state. Refer to the procedures on starting the system, shutting down the system, suspending system operation, and resuming system operation given later in this chapter.

† Your system may be configured to use either Sleep mode or Hibernate mode.

When you use your Tablet PC, you can change the current system state in a number of ways, depending on the system's current state. To determine the current system state, observe the Power icon in the Status display. Table 1 on page 48 gives the different system states represented by the Power icon and describes how you can change the system state from the current state.

Proper Tablet PC Orientations

Your computer can be used in in two different orientations.

Portrait Orientation: Hold the system with the fingerprint sensor positioned vertically on the left.

Landscape Orientation: Hold the system with the fingerprint sensor positioned horizontally on the top.

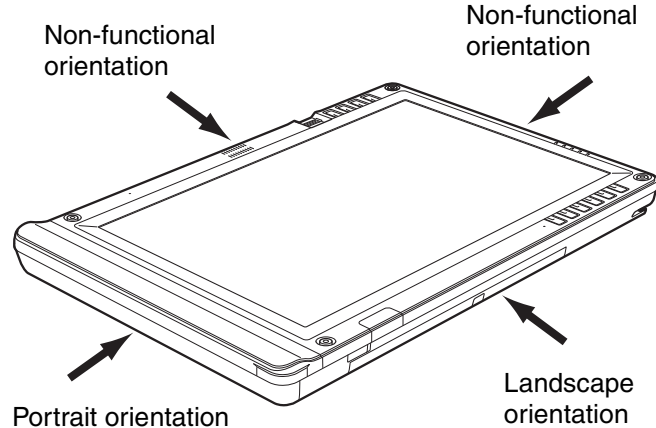

Table 1. Holding the Tablet PC

Starting the Tablet PC

Powering Up

Follow the procedure below to start your Tablet PC. Before you begin, confirm that the system is in the Off state. To do so, observe the Status display. If the Power icon is not visible in the Status display, the system is in Off state or in Hibernate mode and it is safe to perform this procedure. If the Power icon is visible (either blinking or on continuously), do not perform this procedure. See “System States” earlier in this chapter for details on modes represented by the Power icon.

- 1 Ensure that the battery in your Tablet PC is sufficiently charged, or connect an external power source such as the AC adapter or auto adapter to your Tablet PC.

- 2 Press the Power On/Suspend/Resume button to start the system. After performing initialization, the system starts the operating system installed on the hard disk drive. Once the operating system is running, you can use the system.

Booting the First Time

We strongly recommend that you not attach any external devices until you have gone through the initial power on sequence.

When you turn on your tablet for the first time, it will display a Fujitsu logo on the screen. If you do nothing the system will load the operating system, and then the Windows Welcome will begin.

Depending upon your operating system (Windows Vista or XP edition), there is a different procedure for stating your system for the first time, as outlined below.

Starting Windows Vista the first time



THE FIRST TIME YOU INITIALIZE YOUR WINDOWS VISTA SYSTEM, THE SCREEN WILL BE BLANK FOR APPROXIMATELY TWO MINUTES. THIS IS NORMAL. AFTER INITIALIZATION, A “SET UP WINDOWS” DIALOG BOX WILL APPEAR.

IMPORTANT: DURING THE SETUP PROCEDURE, DO NOT DISCONNECT THE POWER SUPPLY, PRESS ANY BUTTONS, OR USE ANY PERIPHERAL DEVICES SUCH AS A MOUSE, KEYBOARD, OR REMOTE CONTROL.

In order to ensure that you receive the most benefits from the Windows Vista operating system, it should be registered the first time you use it.

- 1 First of all, you will need to read and accept the End User License Agreements (EULAs).



- IF YOU REJECT THE TERMS OF THE LICENSE AGREEMENTS YOU WILL BE ASKED TO REVIEW THE LICENSE AGREEMENTS FOR INFORMATION ON RETURNING WINDOWS OR TO SHUT DOWN YOUR TABLET PC.
- YOU CANNOT USE YOUR TABLET UNTIL YOU HAVE ACCEPTED THE LICENSE AGREEMENTS. IF YOU STOP THE PROCESS YOUR TABLET WILL RETURN TO THE BEGINNING OF THE WINDOWS WELCOME PROCESS, EVEN IF YOU SHUT YOUR TABLET DOWN AND START IT UP AGAIN.

- 2 You will be prompted to enter your User Name and Password and you will be given a chance to select an icon for your account.
- 3 The next screen asks for a Computer Name and allows you to choose a desktop background.
- 4 You will next see a "Help protect Windows automatically" screen in which the default choice is "Use recommended settings". The other two choices are "Install important updates only" and "Ask me later". Select from the three choices.
- 5 On the next screen set your time and date settings.
- 6 You will next see the "Select your computer's current location" screen. Make your selection from Home, Work (Default), and Public location.
- 7 The "Thank you" screen follows and an offer for free Norton Internet Security is extended. Following are several screens while Windows checks the system performance.
- 8 Windows will then boot up for the first time. After the first boot, press [Execute] to install the Primary Settings. This will take several minutes.
- 9 After the Primary Settings are installed, reboot the system again.

Registering Windows Vista with Microsoft

- 1 After Windows has booted up for the first time, the Control Panel Welcome Center will appear. If the Register Windows Online icon is not seen in the window, click on "Show all xx items" (where "xx" is the number of topics in the Welcome Center).
- 2 Click on Register Windows Online and follow the instructions that appear to register your copy of Windows.

Registering Windows XP with Microsoft

In order to ensure that you receive the most benefits from the Windows operating system, it should be registered the first time you use it.

After you receive the Windows Welcome screen, you will be prompted to enter registration information in the following order.

First of all, you will need to read and accept the End User License Agreements (EULAs). After accepting the EULAs, you will be asked if you want to enable the Automatic Updates feature. Acceptance of this feature is recommended because it allows your system to be updated automatically whenever an important change becomes available for your tablet.



- IF YOU REJECT THE TERMS OF THE LICENSE AGREEMENTS YOU WILL BE ASKED TO REVIEW THE LICENSE AGREEMENTS FOR INFORMATION ON RETURNING WINDOWS OR TO SHUT DOWN YOUR TABLET PC.
- YOU CANNOT USE YOUR TABLET UNTIL YOU HAVE ACCEPTED THE LICENSE AGREEMENTS. IF YOU STOP THE PROCESS YOUR TABLET WILL RETURN TO THE BEGINNING OF THE WINDOWS WELCOME PROCESS, EVEN IF YOU SHUT YOUR TABLET DOWN AND START IT UP AGAIN.

Several additional windows will appear, prompting you to enter a name and description for your computer, an Administrator password, and a domain name. Read the instructions on the screens carefully and fill in the information as directed.

You will then be automatically connected to the Internet, if you have an appropriate connection available. If an automatic connection is not possible, you will be asked about how you dial out from where you will be using your tablet. If you are not connected to a phone line and plan to register at a later time, you may click the **Skip** button.

Once you are connected to the Internet, you will be asked if you wish to continue with the registration. If you select **Yes** you will then enter your name and address, and email address if desired. Click **Next** to complete registration.

Registering Your Stylistic Tablet PC with Fujitsu

You can register your tablet by going to our website at: us.fujitsu.com/computers

You will need to be set up with an Internet Service Provider (ISP) to register online.

Shutting Down

Follow these steps to shut down/turn off your system:

- 1 If system operation has been suspended, resume system operation. See “Resuming System Operation” later in this chapter for details.
- 2 Save your work and close all running programs.
- 3 Choose Shut Down from the Windows Start menu.
- 4 Carry out the Shut Down command.

The system is now in the Off state.

Suspending System Operation

The Tablet PC allows you to suspend the system operation without closing programs or exiting the operating system. Use this feature to conserve battery power when a system shutdown is not practical or when the battery needs to be changed.



IF YOU HAVE SET YOUR SYSTEM TO TURN POWER OFF FROM THE POWER OPTIONS UTILITY IN THE CONTROL PANEL, THE FOLLOWING PROCEDURE WILL NOT BE POSSIBLE, SINCE PRESSING THE BUTTON SHUTS THE SYSTEM DOWN RATHER THAN SUSPENDING IT. TO CHANGE YOUR POWER OPTIONS, GO TO START -> SETTINGS -> CONTROL PANEL -> POWER OPTIONS.

To suspend system operation:

- 1 Press the Suspend/Resume button, or carry out the Sleep command from your operating system or power management program. (If your system is configured to suspend operation using Hibernate mode, which is explained later in this procedure, a message is displayed while data is saved to your hard disk.)
- 2 The Power icon either flashes (Sleep) or is not displayed (Hibernate) when system operation is suspended, depending on how your system is configured. At this point, programs that were running are stopped, active data is saved, and the system enters one of two different low-power states, or sleep modes, as explained in the following paragraphs.



IF YOU ARE REPLACING THE BATTERY, **WAIT UNTIL SYSTEM OPERATION IS SUSPENDED AND THE POWER ICON IS FLASHING** BEFORE YOU REMOVE THE BATTERY. FAILURE TO DO SO COULD RESULT IN LOSS OF YOUR UNSAVED DATA. (NOTE THAT IF THE RESUME ON LAN FUNCTION IS ENABLED IN THE BIOS SETUP, YOU SHOULD **NOT** REMOVE THE BATTERY UNLESS THE SYSTEM IS SHUT DOWN. WHEN RESUME ON LAN IS ENABLED, THE BRIDGE BATTERY IS DISABLED IN ORDER TO OPTIMIZE BATTERY LIFE.)

- 3 Observe the Power icon in the Status display to determine which suspend mode your system is using.
 - **Power icon is blinking:** *Sleep* mode.

In this mode, active data is saved by maintaining power to RAM while most other system components are powered off. The Battery Gauge icon in the Status display indicates the battery charge level.
 - **Power icon is not displayed:** *Hibernate* mode.

In this mode, active data is stored on the hard disk drive and power usage is reduced to the same level used in the Off state. When the system is in *Hibernate* mode, the Battery Gauge icon is not visible in the Status display. In this mode, there is no danger of losing data if battery power is lost.

If you have successfully performed this procedure, system operation is now suspended. Refer to “Resuming System Operation” later in this chapter to resume system operation. Also, note the following with regard to suspending system operation:

- You can remove the battery while the system is in Sleep or Hibernate modes in order to install a charged battery. To prevent losing unsaved data, wait until system operation has suspended before you remove the battery. Note that after you remove the battery, you have approximately five minutes to replace it with a new battery or to plug in a power supply before the bridge battery is depleted.
- Your system may be configured to suspend operation automatically after a period of inactivity.
- Your system may be configured to enter Hibernate mode automatically after a period of time in Sleep mode.

- The system uses a small amount of battery power when in Sleep mode. Eventually, the battery will become fully discharged.



IF YOU WILL NOT BE USING THE SYSTEM FOR AN EXTENDED PERIOD, SHUT DOWN THE SYSTEM RATHER THAN USING SLEEP MODE.

- If the battery charge drops to a Low-Battery Warning level while the system is running, the system will beep periodically. If this occurs, suspend system operation, shut down the system, or attach an external power source, such as the AC adapter, to the Tablet PC.
- If the battery charge drops to a Critically Low level while the system is running, the system is forced into a Sleep or Hibernate mode. If this occurs, you must either install a charged battery, or connect an external power source such as the AC adapter before you can resume system operation. (If the charge drops to a Critically Low level while the system is *in* Sleep mode, the system stays in that mode until power is restored or totally dissipated.)
- Suspending system operation interrupts data communications; therefore, some programs may block the system from suspending to prevent an interruption.
- The suspend action of the Suspend/Resume button may be disabled to prevent accidental interruption. If this is the case, pressing the Suspend/Resume button will not suspend system operation as described here. (In this case, sleep mode can only be achieved using the system software). Contact your local help desk or reseller if your system configuration is not suitable.
- If your system is equipped with a PC Card that allows you to connect to a wired or wireless network, you may be logged off the network after a period of inactivity while system operation is suspended. Contact a network administrator or help desk, or call Fujitsu Service and Support at 1-800-8Fujitsu (1-800-838-5487) for details on your network log-off parameters.

Resuming Operation

To resume operation from either Sleep or Hibernate modes, press the Suspend/Resume button.

- **From Sleep mode**

Status lights indicate that the system state is changing. It may take up to a minute before the system returns to the On state and system operation resumes. Note that the display turns on shortly before the pen becomes active due to the power-up sequences observed by the system.

- **From Hibernate mode**

Active data is read from the hard disk drive, and the system returns to the On state after a short time.



NOTE THAT POWER TO SEVERAL SYSTEM COMPONENTS MUST BE RESTORED BEFORE SYSTEM OPERATION RESUMES. ALLOW SUFFICIENT TIME FOR SYSTEM OPERATION TO RESUME BEFORE ATTEMPTING TO USE THE SYSTEM. IF YOUR SYSTEM USES HIBERNATE MODE, IT WILL TAKE LONGER TO RESUME OPERATION AS COMPARED TO USING SLEEP MODE. TIME IS NEEDED TO READ DATA FROM THE HARD DISK DRIVE.

Use the system as you normally would once system operation resumes.

All programs resume at the point where execution stopped when system operation was suspended.

Productivity Applications and Utilities

Depending upon your system, one of the following productivity applications is installed on your system:
TBD

Microsoft Office Ready

With Office Ready PCs it's now even easier to take advantage of Microsoft® Office 2007. The full versions of Microsoft® Office Basic, Small Business and Professional 2007 are already preinstalled on your PC, so there's nothing to install, and all Office Ready PCs give you the option to activate a 60 day trial of Microsoft® Office Professional 2007! All you need to do is purchase the appropriate Office 2007 license kit which allows you to "un-lock" the full version of Office that you want.

Fujitsu offers a Media License Kit for Microsoft® Office Small Business 2007. Simply enter your product key and you're ready to go.

Another option is to purchase a Microsoft® Office 2007 media-less license kit (MLK) from either your computer reseller or online from Microsoft within 90 days of the purchase of your computer.

Microsoft Office OneNote® 2007

Microsoft® Office OneNote® 2007 is a digital notebook that provides a flexible way to gather and organize your notes and information, powerful search capabilities so you can find what you're looking for quickly, and easy-to-use shared notebooks for teams to work together more effectively. Unlike paper-based systems, word processing programs, e-mail systems, or other productivity programs, Office OneNote® 2007 delivers the flexibility to gather and organize text, pictures, digital handwriting, audio and video recordings, and more — all in one digital notebook on your computer. Office OneNote® 2007 can help you become more productive by keeping the information you need at your fingertips and reducing time spent searching for information across e-mail messages, paper notebooks, file folders, and printouts.

Using the Shock Sensor Utility

Shock Sensor Utility is designed to decrease the risk of damage to the computer's hard disk drive (HDD) in the event of excessive impact or vibration. The Shock Sensor Utility also improves the security of the computer by automatically locking the computer with a password when it is carried. Note that the HDD protection and computer locking features are mutually exclusive; both cannot be selected at the same time.



- SHOCK SENSOR UTILITY DOES NOT COMPLETELY PROTECT THE HDD AND DOES NOT PROVIDE ABSOLUTE SECURITY FOR THE COMPUTER.
- THE COMPUTER MAY STOP TEMPORARILY WHILE THE HDD HEAD IS RETRACTED. TO RESTART THE COMPUTER, KEEP THE SYSTEM HORIZONTAL.

- 1 Double-click the Shock Sensor Utility icon in the system tray at the bottom-right of the screen. The [Shock Sensor Utility] window appears.
- 2 Click the red [Setting] button. The [Shock Sensor Utility Settings] window appears.

Action

Select the action you wish this utility to perform:

- **Protect HDD from impact.** HDD head is retracted when an impact to the computer is detected.
- **Lock computer when carried.** Lock the computer when it is being carried.
- **Nothing.** No action.

Sensitivity of impact/horizontal move/fall/carry detection

Adjust the sensitivity of the acceleration sensor based on system motion or impact.

Ignore periodic vibration.

If vibration is periodic, disregard it.

Ignore mouse click

When the mouse is clicked, sensitivity is temporarily lowered.

Ignore keyboard action

When the keyboard is used, sensitivity is temporarily lowered.

Confirm calibration when user logs on

Select [Confirm calibration when user logs on] if you want to recognize the current orientation as horizontal at logon.

Perform calibration automatically when user logs on

Select [Perform calibration automatically when user logs on] if the system is normally used on a horizontal surface.

[Calibrate Now]

The calibration is executed. Please position the computer as horizontally as possible, then click the [Calibrate Now] button. The current horizontal position will be recognized as the true horizontal by performing the calibration.

3 Click the [OK] or [Cancel] button. The [Setup] window closes.

Using the Shock Sensor Monitor Window

Right-click the Shock Sensor Utility icon in the system tray at the bottom-right of the screen, and select [Monitor] from the menu. The Monitor window appears.

Note that the Monitor is designed for entertainment, and has no effect on system settings or orientation. To navigate the monitor, use the buttons described below.

- **Advance.** Incline the display to the hinge side, or use [Up] key.
- **Back.** Incline the display to the mouse-button side, or use [Down] key.
- **Right.** Incline the display to the right side, or use [Right] key.
- **Left.** Incline the display to the left side, or use [Left] key.
- **Go up.** Use [A] key.

- **Go down.** Use [Z] key.
- **Close.** Use [Esc] key.

Display Profiles

The Fujitsu Tablet Controls utility allows you to set different display configurations when the system is undocked, docked in portrait mode, and docked in landscape mode. When the tablet transitions between these three configurations, the selected configuration will automatically be applied.

Setting Display Profiles

To change display configurations, perform the following steps:

- 1** Go to Start > Control Panel.
- 2** Open “Intel® GMA Driver for Mobile”.
- 3** Modify the settings to your desired configuration. You will be able to change the Display mode and Display Settings for all available monitors.
- 4** Once the desired configuration is applied, go to the Control Panel and open “Fujitsu Tablet Controls”.
- 5** On the “Fujitsu Tablet Controls” click “Save Current Profile”.

Repeat the above steps for all three modes of the slate:

- a) when the system is docked in landscape mode,
- b) when the system is docked in portrait mode, and,
- c) when the system is undocked.

Adjusting the Display Brightness

There are four ways to adjust your display’s brightness:



DEPENDING UPON WHETHER YOU ARE RUNNING YOUR SYSTEM ON BATTERY OR AC POWER, THE DEFAULT SCREEN BRIGHTNESS SETTINGS WILL BE DIFFERENT. THE SCREEN BRIGHTNESS DEFAULT FOR RUNNING ON BATTERY IS LOWER THAN THAT ON AC POWER IN ORDER TO OPTIMIZE BATTERY LIFE.

- *Windows XP Tablet PC:* Click the Tablet icon in the system tray at the bottom right of the screen. (When the cursor is on top of the icon, a message stating “Change tablet and pen settings” is displayed.) When the Tablet and Pen Settings window appears, select the Display tab, and move the Screen Brightness slider to change the brightness.
Windows Vista: Open the Windows Mobility Center control panel by right-clicking on the Power Options (battery) icon in the system tray. From there you can adjust display brightness.
- Click Start -> Control Panel -> Tablet and Pen Settings. Select the Display tab, and move the Screen Brightness slider to change the brightness.
- Click the Fujitsu Menu icon in the system tray at the bottom right of the screen. (When the cursor is on top of the icon, a message stating “Fujitsu Menu...” is displayed.) Select Tablet and Pen Settings and select the Display tab. Move the Screen Brightness slider to change the brightness.
- Press the Fn key twice to invoke the Fujitsu menu and select Tablet and Pen Settings.

Using the Pen

You can use the Stylistic ST6000 Series pen to generate and create electronic “ink”, to select items, and to navigate through programs on the Tablet PC. Programs that support handwriting recognition also allow you to write characters directly on the screen with the pen. You can also use the pen as a drawing tool.

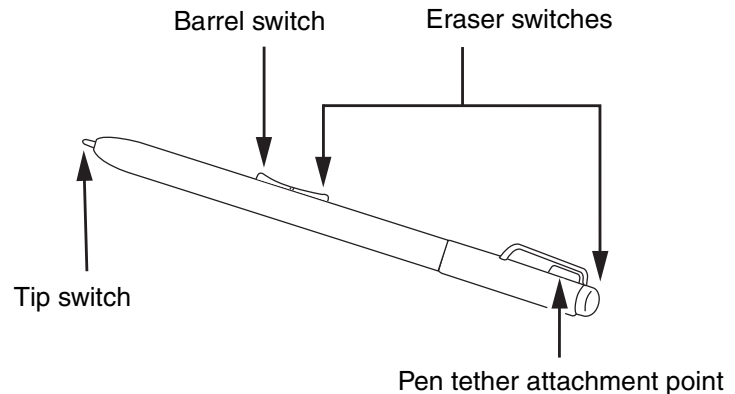

TBD - VERIFY PEN CONFIG

Figure 9. Stylistic ST6000 pen

THE STYLISTIC ST6000 PEN IS A SOPHISTICATED, HIGH-QUALITY ELECTRONIC INSTRUMENT THAT CAN BE DAMAGED IF USED IMPROPERLY. TREAT THE PEN AS YOU WOULD ANY PRECISION DEVICE. THE FOLLOWING LIST CONTAINS GUIDELINES FOR PROPER PEN HANDLING:



- DO NOT USE THE PEN AS A POINTER OR TAP IT ON SURFACES OTHER THAN THE TABLET SCREEN.
- DO NOT TRY TO TURN THE THUMB GRIP ON THE PEN; IT IS DESIGNED FOR INSERTING AND REMOVING THE PEN FROM THE PEN HOLDER AND FOR ATTACHING A PEN TETHER.
- NEVER STORE THE PEN WITH THE TIP BEARING THE PEN'S WEIGHT PEN (E.G., SITTING TIP DOWN IN A PENCIL CUP). STORING THE PEN TIP DOWN COULD DISTORT THE INTERNAL MECHANISM OVER A PERIOD OF TIME (ESPE-CIALLY IN HIGHER TEMPERATURES), CAUSING THE TIP TO ACT AS IF IT IS ALWAYS DEPRESSED. TO AVOID DAMAGE, STORE THE PEN IN THE PEN HOLDER WHEN NOT IN USE.

The screen reacts when the pen tip is approximately 1/8 inch (3-5 mm) from the screen. The pen has four switches: a tip switch, a barrel button toggle switch with switches at both ends, and an "eraser" switch, located on the end of the barrel. By default, the tip switch corresponds to the left mouse button, and the

front toggle (closest to the pen tip) barrel button switch corresponds to the right mouse button (when used in combination with the tip switch). The rear toggle of the barrel button switch and the eraser switch at the end of the barrel act as electronic ink “erasers”.

The rear toggle, eraser, and tip click pressures can be changed by clicking [Start] -> Control Panel, and double-clicking Fujitsu Pen Settings (XP) or Pen and Input Devices (Vista) icon. Note that the rear toggle switch and the eraser switch are both affected by the same settings; they cannot be changed individually.

To change rear toggle and eraser button functions, select the drop-down list to select a new function, then click [Apply]. If you don't want the rear toggle and button switch to have any function, select Ignore.

Adjusting the click pressure determines how much pressure must be put on the pen tip in order for the screen to react. The softer it is set, the less pressure required; the harder it is set, the more pressure required. To change the click pressure, use the slider bar to make the click pressure harder or softer, then click [Apply].



- ENSURE THAT A SCREEN PROTECTOR IS INSTALLED ON THE TABLET PC SCREEN BEFORE YOU USE THE PEN. THE WARRANTY DOES NOT COVER A SCRATCHED SCREEN.
- USE **ONLY** THE PEN PROVIDED WITH YOUR TABLET PC. DO NOT USE SUBSTITUTES THAT WERE NOT DESIGNED FOR THE STYLISTIC ST6000 SERIES TABLET PC.

Here are some hints that may help you use the pen more effectively:

- To activate the tip switch, tap or hold the pen tip against the screen.
- To activate the barrel button switch, press and hold the end of the button you wish to use (front toggle is the right mouse button switch; the rear toggle acts as an electronic “eraser”).
- To move the cursor, hold the pen tip within 1/8 inch (3 - 5mm) from the screen and move the pen.
- To start a program, double-tap the pen tip (tap the pen tip twice rapidly) on the program icon as you would double-click a mouse.
- **To select an object**, tap the pen tip on the object once.
- **To “double-click” an object**, tap twice on the object quickly.

- **To move, or “drag”, an object on the screen**, place the pen tip directly over the object, then as you hold the pen tip against the screen, move the pen.

Calibrating the Pen

In order to ensure accurate tracking between the pen and cursor, you must run the Touch Screen Calibration Utility before you use the active digitizer for the first time, or after you change the display resolution.

To run the calibration utility:

- 1** Go to **Start -> Control Panel** and double-click on the **Tablet and Pen Settings** icon.
- 2** Click **Calibrate**.
- 3** Adjust the display of your Tablet PC to a comfortable angle.
- 4** Using the pen, firmly touch the screen directly on the **(+)** symbol; the **(+)** symbol will move to the next location.
- 5** Repeat step 4 in the four corners, then click **OK**.

Installing a Pen Tether

To prevent dropping or losing your pen, you should attach it to the system using the pen tether that is included with the system.

To attach the pen tether to your Tablet PC, perform the following steps:

- 1** Attach the end of the pen tether with the smaller loop to your pen. To do so, push the end of the tether through the hole in the pen, then thread the opposite end of the tether through the loop.
- 2** Attach the end of the pen tether with the larger loop to the attachment point on your pen tablet. To do so, insert the end of the pen tether through the attachment point, then feed the pen through the large loop in the tether.

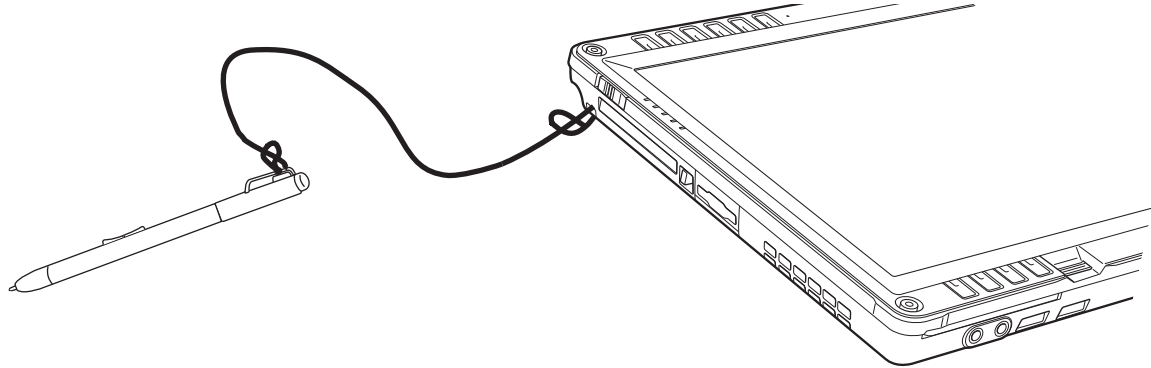

Figure 10. Installing a Pen Tether

Replacing the Pen Tip

With use, the pen tip may become worn or may pick up foreign particles that can scratch the screen. A damaged or worn tip may not move freely, causing unpredictable results when using the pen. If your pen exhibits these problems, you should replace the pen tip. To do so, use the pen tip removal tool included with your pen.

To remove the tip, position the tip in the gap between the two ends of the tool. Pinch the tool together so the tip is firmly clasped, then pull it from the barrel. If the tip is worn or damaged, discard it.

To replace the tip, retrieve one of the new tips that accompanied your pen. Insert the flat end of the tip into the barrel and push it in firmly until it is seated.

If you need more tips, they can be ordered from the Fujitsu website at: us.fujitsu.com/computers.

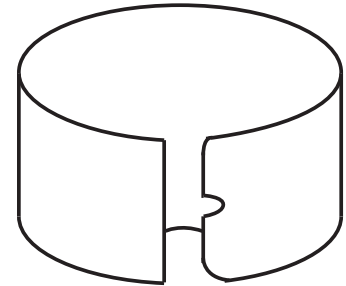

Figure 11. Tip Removal Tool

User-Installable Features

Lithium ion Battery

Charging the Battery

The Stylistic ST6000 Series battery can be charged while it is installed in the Tablet PC. To charge the battery:

- 1** Connect a DC power source, such as the AC adapter, to the DC input connector on the Tablet PC. The DC Input icon appears in the Status display. If the battery charge is below 90%, the battery begins charging and the Charging icon appears in the Status display. If the battery charge is 90% or higher *when you connect* DC power, the battery will not charge, preventing battery overcharging.
- 2** Look at the Battery Charge icon in the Status display to determine the percent of charge in the battery. See “Status Display” in Chapter 1 of this manual for a description of the Battery Charge icon.

As long as DC power *remains connected* to the Tablet PC, the charging process continues until the battery charge reaches 100%.

Also note the following with respect to charging the battery:

- You can use the system, suspend system operation, or shut down and turn off the system without interrupting the charging process; however, using the system while the battery is charging will cause the battery to charge at a slower rate.
- As noted in the procedure above, the system will not begin charging the battery if the battery charge level is 90% or higher when the system is *initially connected* to external DC power. (This prevents the battery from being overcharged.)
- The battery uses Lithium ion battery cells which have no “memory effect.” You do not need to discharge the battery before you begin charging.

Removing and Installing the Battery

The battery can be removed from the Tablet PC and swapped with a charged battery. The battery can then be charged in an external charger if one is available.

To remove the battery from the Tablet PC:

- 1 Choose one of the following:
 - If a charged battery is available, you can suspend system operation. A built-in “bridge” battery will maintain the system in Sleep mode for about 5 minutes while the battery is removed; this allows time for replacement with a charged battery.
 - If a charged battery is not available, save your work and close all running programs, then shut down the system or Hibernate.
 - Plug in an external DC power source.

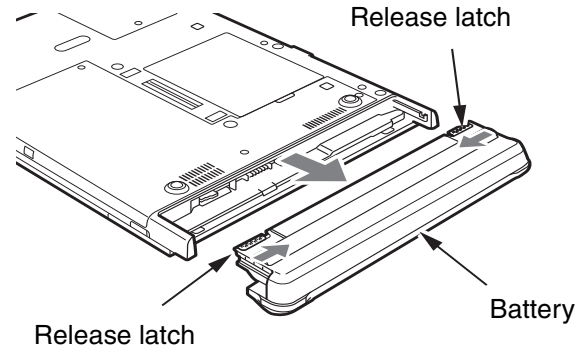

Figure 12. Removing the battery

- 2 Slide the battery release latches in the direction indicated. (See Figure 12.)
 - 3 Pull the battery away from the system, as shown in the illustration and remove the battery from the Tablet PC.
- If you are using an external battery charger, refer to the instructions provided with the battery charger.



UNDER FEDERAL, STATE, OR LOCAL LAW, IT MAY BE ILLEGAL TO DISPOSE OF BATTERIES BY PUTTING THEM IN THE TRASH. BE SURE TO DISPOSE OF BATTERIES IN ACCORDANCE WITH LOCAL GOVERNMENT REGULATIONS.

To install the battery:

- 1 Orient the battery with the slides in the empty battery tray. Slide the battery into the tray and press it firmly until it is seated. When it is properly seated, the battery release latches will return to position and lock the battery.
- 2 Once the battery is installed, you can resume system operation or start and use your system normally.

Tips for Conserving Battery Power

You can extend the charge life of your battery by conserving battery power. (Your results may vary depending on your application and how the system is configured.) Here are some suggestions to help you conserve battery power:

- Use an external power source such as the AC adapter whenever the system is docked.
- Suspend system operation if you know that you won't be using the system for a while.
- Shut down the system if you won't be using the system for an extended period of time.
- Switch the wireless LAN switch Off when wireless LAN functionality is not needed (applicable only for systems with optional wireless LAN).
- Use power management (available from the Power Options in the Control Panel) to help you conserve power automatically.
- Reduce the brightness of the LCD.
- Battery life is dependent upon the operating system, power settings, and applications in use.

Operation of the Bridge Battery

When installed in the Tablet PC, the battery provides power to some system components—even when the system is in the Off state. When the battery is removed, power is supplied to these components by a “bridge” battery that is built into the Tablet PC.

The bridge battery is not designed for long-term operation. To maintain the bridge battery properly, observe the following measures:



- THE BRIDGE BATTERY FUNCTION IS DISABLED IF WAKE ON LAN IS ENABLED IN THE BIOS.
 - THE SYSTEM ARRIVES WITH THE BRIDGE BATTERY IN A DISCHARGED STATE. BE SURE TO CHARGE IT SUFFICIENTLY BEFORE RELYING UPON IT TO SUPPORT THE SYSTEM IN THE EVENT OF BATTERY REMOVAL.
-
- To prevent draining the bridge battery, always store the system with a charged battery installed.
 - If the bridge battery becomes drained, it takes approximately 8 hours for it to be fully recharged.

- The bridge battery charges when the AC Adapter is connected and the system is in On or Off states or Sleep mode. It charges from the battery only when the system is in the On state.

Memory Stick/SD Card Slot

Your Tablet PC supports Memory Stick and SD flash memory cards on which you can store and transfer data to and from a variety of digital devices. These cards use flash memory architecture, which means they don't need a power source to retain data.

Memory Stick is a flash memory technology developed by Sony Electronics. Memory Stick allows you to record, transfer and share digital content, such as digital pictures, movies, music, voice, and computer data and applications.

Secure Digital (SD) Cards are very similar to Memory Sticks, but they are shorter. Like the Memory Stick, SD Cards allow portable storage among a variety of devices, such as cell phones, GPS systems, and digital cameras. SD Cards transfer data quickly, with low battery consumption. It uses flash memory architecture.

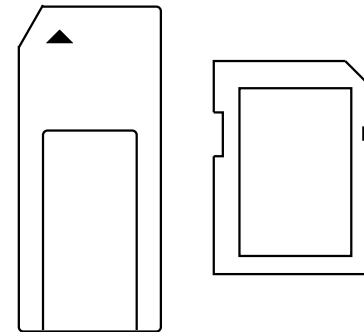

Figure 13. Memory Stick and SD Card

Inserting Memory Stick/SD Cards

Memory Sticks and SD Cards are inserted in the Memory Stick/SD Card slot (Figure 14). To insert a Memory Stick or SD Card, follow these steps:



- INSERTING OR REMOVING A MEMORY STICK OR SD CARD DURING YOUR SYSTEM'S SHUTDOWN OR BOOTUP PROCESS MAY DAMAGE THE CARD AND/OR YOUR COMPUTER.
- DO NOT INSERT A CARD INTO A SLOT IF THERE IS WATER OR ANY OTHER SUBSTANCE ON THE CARD AS YOU MAY PERMANENTLY DAMAGE THE CARD, YOUR TABLET PC, OR BOTH.

- 1 See your Memory Stick or SD Card manual for instructions on the insertion of your card. Some cards may require that your system is off while inserting them.
- 2 Make sure there is no card currently in the slot. If there is, see Removing a Memory Stick/SD Card.
- 3 Insert your card into the slot with the product label facing up.
- 4 Push the card firmly into the slot until it is seated in the connector.

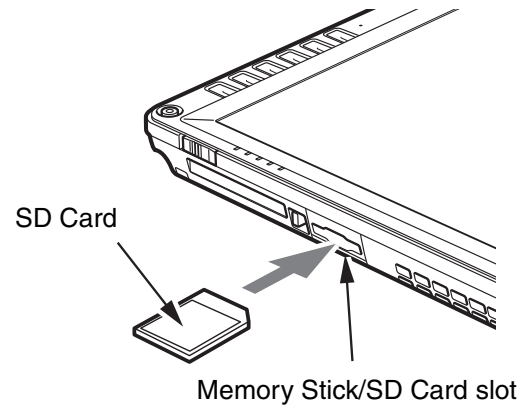

Figure 14. Inserting an SD Card

Removing A Memory Stick/SD Card

To remove a Memory Stick/SD Card, follow these steps:



SEE YOUR MEMORY STICK OR SD CARD MANUAL FOR SPECIFIC INSTRUCTIONS ON THE REMOVAL OF YOUR CARD. SOME CARDS MAY REQUIRE YOUR COMPUTER TO BE IN SLEEP MODE OR OFF WHILE REMOVING THEM.

Push the Memory Stick or SD Card in until it unlatches. It will then eject from the slot for removal

PC Card Slot

The Stylistic ST6000 Series Tablet PC Card slot allows you to insert a Type I or Type II PCMCIA Card.

Inserting a PC Card

To insert a PC card, position the side with the arrow facing up (i.e., when looking at the tablet's display side, the arrow on the card should be visible.) Slide the card into the PC Card slot, and press it firmly to ensure proper seating. (See Figure 15 for location)

If you need assistance inserting a PC Card in the Stylistic ST6000 Series Tablet PC, contact your corporate help desk or reseller.

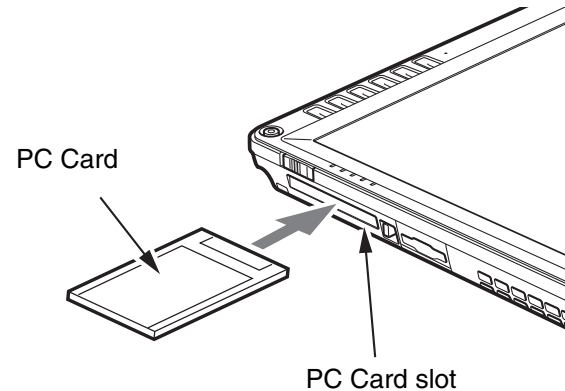

Figure 15. Inserting a PC Card

Removing a PC Card

To remove a PC Card, first click the Safely Remove Hardware icon in the system tray in the bottom right-hand corner of the display. Select PC Card from the list, and click [Stop].

Press the PC Card eject button so that it pops out. Once the button has popped out, press it firmly to eject the card.

Removing and Installing Memory

There are two DIMM slots in your Tablet PC. 256 MB, 512 MB, 1 GB, and 2 GB modules are available, so you can install a combination of up to 4 GB in the system.



- DO NOT REMOVE ANY SCREWS FROM THE MEMORY UPGRADE MODULE COMPARTMENT EXCEPT THE ONES SPECIFICALLY SHOWN IN THE DIRECTIONS FOR INSTALLING AND REMOVING THE MEMORY UPGRADE MODULE.
- THE MEMORY UPGRADE MODULE CAN BE SEVERELY DAMAGED BY ELECTROSTATIC DISCHARGE (ESD). TO MINIMIZE RISK, OBSERVE THE FOLLOWING PRECAUTIONS:
 - BEFORE HANDLING A MEMORY MODULE, TOUCH A GROUNDED METAL OBJECT TO DISCHARGE STATIC ELECTRICITY BUILT UP IN YOUR BODY.
 - WHEN INSTALLING OR REMOVING A MEMORY MODULE, HOLD IT BY THE EDGE SO AS NOT TO TOUCH ANY CONTACTS OR CHIPS. BE CAREFUL NOT TO TOUCH ANY COMPUTER TERMINALS OR COMPONENTS; THE OIL FROM YOUR FINGERS COULD CAUSE A SHORT.
- BE SURE TO POWER DOWN YOUR SYSTEM BEFORE ADDING OR REMOVING MEMORY MODULES. EVEN IF THE SYSTEM IS IN HIBERNATE OR SLEEP, DATA COULD BE LOST OR MEMORY COULD BE DAMAGED IF POWER IS STILL AVAILABLE TO THE SYSTEM.

Installing a Memory Module

To install a DIMM module in the Tablet PC:

- 1** Ensure that the Tablet PC is off. To do so, carry out the Shut Down command in the Start menu. (Do not attempt to remove or install a DIMM module when the system is in Sleep mode or running.)
- 2** Remove the two screws from the cover plate on the back of the Tablet PC and remove the cover plate as shown in Figure 16.
- 3** Insert the DIMM module in the socket at an angle and push it down until it locks into place as shown in Figure 17. Note that the DIMM module is keyed to prevent it from being inserted backwards.
- 4** Reinstall the cover and screws that you removed in step 2.
- 5** Confirm that the DIMM module is recognized by the system. To do so, run BIOS Setup. The size of the DIMM module should be displayed in the Info menu in BIOS Setup.

The DIMM module is installed in the Tablet PC and you can now use the system.

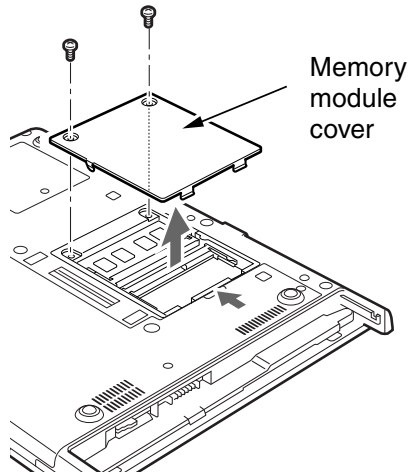

Figure 16. Accessing the Memory Slot

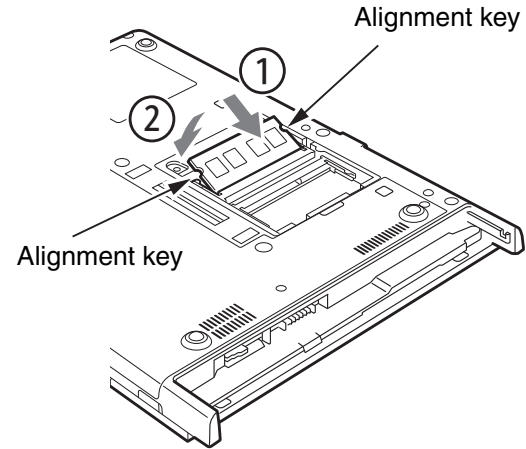

Figure 17. Installing a DIMM Module

Removing a Memory Module

To remove a DIMM module:

- 1** Ensure that the Tablet PC is off. To do so, carry out the Shut Down command in the Start menu. (Do not attempt to remove or install a DIMM module when the system is in Sleep mode or running.)
- 2** Remove the screws from the cover plate on the back of the Tablet PC and remove the cover plate as shown in Figure 16.
- 3** Spread the finger latches on the socket that lock the DIMM module in place until the DIMM module is loose.
- 4** Remove the DIMM module from the socket.

See "Installing a Memory Module" to install a new module.

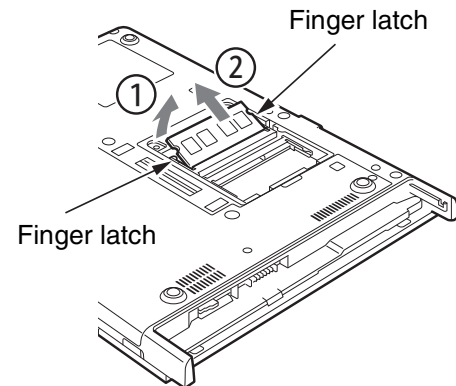

Figure 18. Removing a DIMM Module

Chapter 2

Care and Maintenance

Caring for your Tablet PC

This chapter gives you pointers on how to care for and maintain your Stylistic ST6000 Series Tablet PC.

- IN THE EVENT YOU DROP YOUR TABLET PC OR DAMAGE THE HOUSING IN ANY WAY, IMMEDIATELY TURN OFF POWER AND DISCONNECT THE POWER PLUG. FAILURE TO DO SO COULD RESULT IN A SHORT CIRCUIT, SMOKE, AND/OR FIRE. CONTACT FUJITSU SERVICE AND SUPPORT BY PHONE AT 1-800-8FUJITSU (1-800-838-5487), BY EMAIL AT 8FUJITSU@US.FUJITSU.COM, OR THROUGH THE WEBSITE AT [HTTP://WWW.COMPUTERS.US.FUJITSU.COM/SUPPORT](http://www.computers.us.fujitsu.com/support) TO LEARN HOW TO GET THE SYSTEM REPAIRED.
- DO NOT REMOVE ANY SCREWS FROM THE MEMORY UPGRADE MODULE COMPARTMENT EXCEPT THE ONES SPECIFICALLY SHOWN IN THE DIRECTIONS FOR INSTALLING AND REMOVING THE MEMORY UPGRADE MODULE.
- THE MEMORY UPGRADE MODULE CAN BE SEVERELY DAMAGED BY ELECTROSTATIC DISCHARGE (ESD). TO MINIMIZE RISK TO THE MODULE, OBSERVE THE FOLLOWING PRECAUTIONS:
 - BEFORE DOCKING OR UNDOCKING YOUR SYSTEM (WHEN USING A TABLET DOCK) OR HANDLING A MEMORY MODULE, IT IS GOOD PRACTICE TO ALWAYS TOUCH A GROUNDED METAL OBJECT TO DISCHARGE STATIC ELECTRICITY BUILT UP IN YOUR BODY.
 - WHEN INSTALLING OR REMOVING A MEMORY MODULE, HOLD IT BY THE EDGE SO AS NOT TO TOUCH ANY CONTACTS OR CHIPS. BE CAREFUL NOT TO TOUCH ANY INTERNAL COMPUTER TERMINALS OR COMPONENTS; THE OIL FROM YOUR FINGERS COULD CAUSE A SHORT TO THE COMPONENTS.
 - BE SURE TO POWER DOWN YOUR SYSTEM BEFORE ADDING OR REMOVING MEMORY MODULES. EVEN IF THE SYSTEM IS IN HIBERNATE OR SLEEP STATES, DATA COULD BE LOST OR THE MEMORY COULD BE DAMAGED IF POWER IS STILL AVAILABLE TO THE SYSTEM.



Precautions

Please note the following information regarding proper treatment of your Tablet PC:

- Your Tablet PC is a durable but sensitive electronic device. Treat it with respect and care.
- Make a habit of transporting the system in a suitable carrying case.
- Do not attempt to service the computer yourself. Always follow installation and operation instructions closely.
- If you accidentally spill liquid on your Tablet PC:
 - 1** Turn it off.
 - 2** Position it so that the liquid can run out.
 - 3** Let it dry out for 24 hours, or longer if needed.
 - 4** If your Tablet PC will not boot up after it has dried out, call your support representative.
- Do not use your Tablet PC in a wet environment (near a bathtub, swimming pool).
- Always use the AC adapter and batteries that are approved for your system.
- Avoid exposure to sand, dust and other environmental hazards.
- Do not expose your Tablet PC to direct sunlight for long periods of time as excessive temperatures may damage your system.
- Do not put heavy or sharp objects on the computer.
- Do not carry your system in a bag or briefcase while it is running; doing so could result in overheating or hard disk drive problems.
- If you are carrying your system in a briefcase, or any other carrying case, make sure that there are no objects in the case pressing on the display.
- Do not drop your Tablet PC or touch the screen with any sharp objects.

Protecting the Display Screen

The Stylistic ST6000 Series Tablet PC is designed to provide you with years of service. Using a screen protector will help ensure the screen remains as clear as possible. When installed, the screen protector becomes a durable, replaceable writing surface that protects the display screen from abrasion.

To obtain additional screen protectors, use Fujitsu part number FPCSP08AP (6-pack) when ordering. Additional information about installation is included with the screen protectors.



DURING NORMAL USE OF THE TABLET PC, SMALL PARTICLES FROM THE ENVIRONMENT CAN BECOME EMBEDDED IN THE PEN TIP AND SCRATCH THE SCREEN. TO PREVENT SCRATCHING THE SCREEN, ENSURE THAT A SCREEN PROTECTOR IS INSTALLED BEFORE USING YOUR TABLET PC. THE WARRANTY DOES NOT COVER A SCRATCHED SCREEN.

To install a new screen protector on your Tablet PC:

- 1 If a screen protector is already installed on the display screen, remove it before installing the new screen protector. The screen protector is held onto the display screen surface by a thin strip of adhesive around the edges.
- 2 Clean the display by wiping the screen gently using a soft cotton cloth dampened with isopropyl alcohol. Ensure that all residue has been removed from the screen before applying a new screen protector. Remove the protective coating from the adhesive side of the screen protector first.



- THE STYLISTIC ST6000 SERIES TABLET PC IS **NOT WATERPROOF**. DO NOT POUR LIQUIDS ON THE SYSTEM OR WASH IT WITH A HEAVILY SOAKED CLOTH.
- DO NOT PLACE ITEMS ON THE TOP OF THE DISPLAY, OR DAMAGE MAY OCCUR.

- 3 Apply the screen protector to the display screen surface. When doing so, orient the screen protector with the adhesive side of the screen protector facing the display screen as shown in Figure 19.
- 4 Apply pressure to the screen protector with your finger using a continuous wiping motion along the edges. The adhesive sets completely within 48 hours. To ensure a good seal between the screen protector and the display, do not lift the screen protector from the display once it has been applied.
- 5 Remove the protective plastic cover from the face of the screen protector, as shown in Figure 20.

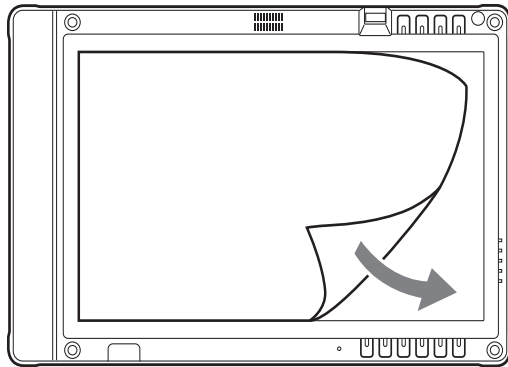

Figure 19. Installing the screen protector

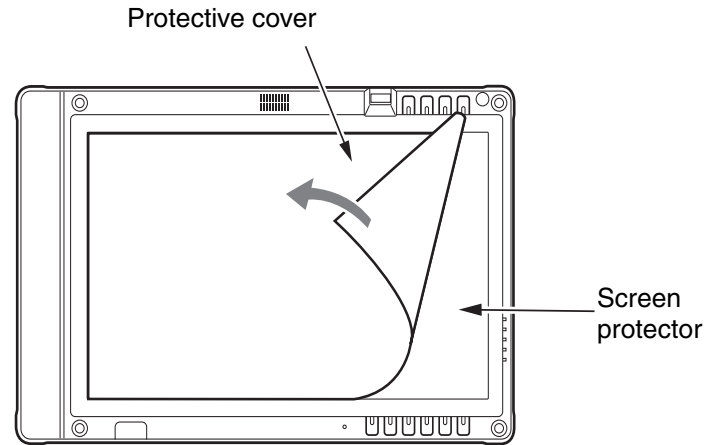

Figure 20. Removing the protective cover

- 6** Clean any residue left behind by the protective coating from the exposed surface of the screen protector by wiping gently with a soft cotton cloth dampened with isopropyl alcohol. Wipe the screen protector with a soft dry cloth to remove any low-tack adhesive; this will help prevent the pen tip from squeaking.

Storing the Tablet PC

Store the Stylistic ST6000 Series Tablet PC in the Off state with a fully charged battery installed. You can store the Tablet PC in the Off state for about 30 days with a fully charged battery installed. After this period, the battery should be recharged or replaced with a charged battery.

If you intend to store the Tablet PC for a longer period of time, the small battery that maintains system time may need to be replaced. Replacement of the clock battery should only be performed by authorized technicians.

Avoiding Overheating



DO NOT EXPOSE YOUR TABLET PC TO DIRECT SUNLIGHT FOR EXTENDED PERIODS OF TIME. HIGH TEMPERATURES COULD DAMAGE YOUR TABLET.

The Tablet PC monitors its internal temperature. As the internal temperature approaches the tolerable limits of heat-sensitive components, system functions are automatically limited or turned off to prevent damage.

To protect your tablet from damage and to optimize performance, **keep all air all vents unobstructed, clean, and clear of debris**. This may require periodic cleaning, depending upon the system environment.

Do not operate the tablet in areas where the air vents can be obstructed, such as in tight enclosures or on soft surfaces like a bed or cushion.

Cleaning the Display Screen

To clean the Tablet PC display screen, wipe the screen surface gently using a soft cotton cloth slightly dampened with water or isopropyl alcohol.



THE TABLET PC IS **NOT WATERPROOF**. DO NOT POUR LIQUIDS ON THE TABLET PC OR WASH IT WITH A HEAVILY SOAKED CLOTH.

Troubleshooting

Solutions to some common problems are described in the following sections. If you are experiencing a problem with your Tablet PC that you cannot solve by taking the actions described, contact your local help desk or reseller, or call Fujitsu Service and Support at 1-800-8Fujitsu (1-800-838-5487) for further assistance.

System Will Not Resume Operation

If the system will not resume operation after system operation has been suspended, check the following:

- The battery may either be defective, or discharged to a critically low level. When the battery reaches a critically low level, the system is forced into Sleep mode to avoid a total system power failure. To correct this problem, either connect an external power supply (such as the AC adapter), or install a charged battery in the Tablet PC.
- The system may be at the critical thermal limit. To avoid damage to heat-sensitive components, the system enters sleep mode when it gets too hot. System operation cannot be resumed until the Tablet PC cools off to a tolerable temperature. Move the Tablet PC to a cooler location.

Display Screen Blank or Difficult to Read

If the display screen on your Tablet PC appears blank or is unreadable, confirm that the system is running (the Power icon is displayed continuously on the Status display), and check the following:

- The system brightness may be set too low, causing the screen to appear too dark. To change system brightness, press the **Fn** button twice to open the Fujitsu menu. Brightness can be adjusted from the menu.
- The video timeout may have expired. Tap on the display screen to reactivate the display. Note that this is a normal, power-saving feature.

Cursor Is Not Tracking Pen

If the cursor on the screen appears to be misaligned with the pen or is not accurately tracking the pen, calibrate the pen. See “Calibrating the Pen” on page 64 for more information.

Infrared Data Transfer Is Not Working

If you are experiencing problems transferring data over the system's infrared interface, note the following:

- Can the IrDA port on the Tablet PC “see” the IrDA port on the other device? A direct line-of-sight path must exist between the IrDA port on the Tablet PC and the IrDA port on the other device.
- The distance between the two devices must not be more than 3 feet.
- The viewing angle from the IrDA port on the Tablet PC must not be more than 15 degrees from a center line between the IrDA port on the Tablet PC and the IrDA port on the other device.
- The device with which you are trying to communicate must be compliant with the IrDA Standard Revision 1.1 (or 1.0).
- It may be necessary for both computers to be using the same network connection protocols.

Tablet PC is Not Responding to the Pen

If the Tablet PC does not respond to the pen, connect an external keyboard to the system to see if it responds to keyboard commands. If the system doesn't respond to a keyboard, the application or system may have crashed, and it may be necessary to reboot the system. If the system responds to a keyboard but not to a pen, contact your local help desk or reseller, or call Fujitsu Service and Support at 1-800-8Fujitsu (1-800-838-5487) for further assistance.

Speaker/Headphone Volume Too Low

If the audio volume on your Tablet PC speaker or external headphones is too low, check the following:

- Ensure the speaker (or headphone output if using headphones) is enabled. To do so, open the Control Panel and double-click on the Sounds and Audio Devices icon. Select the proper tab, and increase the volume using the slider bar. (If you aren't getting any sound, uncheck the Mute box if it is checked.)
- Press the **Fn** button twice to open the Fujitsu menu. Volume can be adjusted from the menu.
- Ensure the mute box in the system volume control (accessible from the system tray) is not set.
- Ensure any volume control in your audio software is set to an audible level.

Configuring Peripheral Interfaces

Certain peripheral devices can be disabled during the BIOS Setup. If the peripheral interface you want to use does not appear to be working with your peripheral device, ensure that it is enabled in the BIOS. Contact your local help desk or reseller, or call Fujitsu Service and Support at 1-800-8Fujitsu (1-800-838-5487) if you need assistance using BIOS Setup.

Restoring the Included Software **TBD - NEW PROCEDURE?**

The Drivers and Applications Restore (DAR) DVD contains sets of device drivers and Fujitsu utilities (in specific directories) that are unique to your computer configuration for use as documented below.



IF YOU HAVE ACCESS TO THE INTERNET, VISIT THE FUJITSU SUPPORT WEBSITE AT:
[HTTP://WWW.COMPUTERS.US.FUJITSU.COM/SUPPORT](http://www.computers.us.fujitsu.com/support) TO CHECK FOR THE MOST CURRENT INFORMATION, DRIVERS AND HINTS ON HOW TO PERFORM RECOVERY AND SYSTEM UPDATES.

Re-Installing Individual Drivers and Applications

The Drivers and Applications CD can be used to selectively re-install drivers and/or applications that may have been uninstalled or corrupted.



THERE MAY BE CERTAIN FREE THIRD-PARTY APPLICATIONS PRE-INSTALLED ON YOUR SYSTEM THAT ARE NOT ON THE DAR CD. THE LATEST VERSIONS OF THE APPLICATIONS CAN BE DOWNLOADED FROM THE THIRD-PARTY'S WEBSITE.

To re-install drivers and/or applications:

- 1** Boot up the system and insert the DAR CD after Windows has started. A Fujitsu Installer screen is displayed after the CD is inserted.
- 2** After reading the License Agreement, click [I agree].
- 3** A window will appear containing a list of applications, drivers, and utilities that you can install from the Drivers and Applications CD.



THE COMPONENTS LISTED ARE COLOR-CODED IN TERMS OF THEIR INSTALL STATUS. BLUE INDICATES THAT THE COMPONENT CAN BE INSTALLED. GREEN INDICATES THAT THE COMPONENT NEEDS TO BE INSTALLED SEPARATELY. GREY INDICATES A COMPONENT THAT IS ALREADY INSTALLED; GREY ITEMS CAN BE REINSTALLED, BUT PRIOR TO INSTALLATION YOU WILL RECEIVE A REMINDER THAT THE COMPONENT IS ALREADY INSTALLED.

- 4 In the list, check off all the components you want to install. If you want to install all components, click [Select All]. Clicking [Select All] will select all of the blue-coded components; you must select grey and green components separately.
- 5 Once you have selected the components you wish to install, click [Install Selected Subsystems]; the components will be installed.
- 6 After the components are installed, click [OK], then click [Yes] when asked if you want to reboot the system.

Restoring the Factory Image



THE RESTORE DISC ONLY RESTORES THE PRIMARY HARD DISK DRIVE. IF YOU HAVE A SECOND PARTITION ON YOUR HARD DRIVE, **IT WILL NOT BE RESTORED** USING THESE UTILITIES.

The Restore Disc that came with your system contains two utilities:

- The **Recovery** utility allows you to restore the original contents of the C: drive.
- The **Hard Disk Data Delete** utility on this disc is used to delete all data on your hard disk and prevent it from being reused. Do not use the Hard Disk Data Delete utility unless you are absolutely certain that you want to erase your entire hard disk, including all partitions.



- THE USE OF THIS DISC REQUIRES THAT YOU HAVE A DEVICE CAPABLE OF READING DVDs ATTACHED TO YOUR SYSTEM. IF YOU DO NOT HAVE A BUILT-IN DVD PLAYER, YOU WILL NEED TO ATTACH AN EXTERNAL PLAYER. FOR MORE INFORMATION ON AVAILABLE EXTERNAL DEVICES, VISIT OUR WEBSITE AT: US.FUJITSU.COM/COMPUTERS.
- THIS DISC CAN ONLY BE USED WITH THE SYSTEM WITH WHICH IT WAS PURCHASED.

BOOT Priority Change

Before restoring an image, you must first verify that your system is set up to boot from the DVD drive. To verify/change the boot-up priority (rather than booting-up from the hard drive or an external floppy disk drive), perform the following steps:

Using SecureCore Menu

To change the priority using the SecureCore menu, simply press the [ent] button when the Fujitsu logo appears after powering on. Select Boot Menu, then select “CD/DVD Drive”.

Using BIOS Setup Utility

- 1** Start your system and press the [Ctl-Alt-Del] button when the Fujitsu logo appears. You will enter the BIOS Setup Utility.
- 2** Using the arrow keys, go to the Boot menu.
- 3** Arrow down to the Boot Device Priority submenu. Press [Enter].
- 4** If “Optical Media Drive” or “CD-ROM Drive” is not at the top of the list, arrow down to the drive in the list, and press the space bar (or the + key) to move it to the top of the list. (The system attempts to boot from the devices in the order in which they are listed.). Note that the BIOS for some systems will indicate “CD-ROM Drive”, even when a DVD drive is connected.
- 5** If you have an *external* DVD drive connected, proceed to the next step; otherwise, proceed to step 7.
- 6** If you have an external DVD drive connected:
 - Select the Advanced menu in the BIOS window.
 - Scroll down to the USB Features submenu and press the Enter key to open it.
 - If Legacy USB Support is disabled, press the space bar to enable it.
 - Scroll down to SCSI SubClass Support and press the space bar to enable it.
- 7** Press [F10], then click on [Yes] to exit the BIOS Setup Utility and return to the boot process.

After you have changed the boot priority, you can restore a backup image when you are booting up.

Procedure

- 1 Turn on the power to your system.
- 2 Ensure that you have a device that can read DVDs either installed in your system or attached externally to it.
- 3 Insert the Restore Disc into the drive tray.
- 4 Reboot your system.
- 5 After the system reboots, follow the instructions that appear to either restore your system image or erase all data from your hard disk.

Automatically Downloading Driver Updates

Your system has a convenient tool called the Fujitsu Driver Update (FDU) utility. With FDU, you can choose to automatically or manually go to the Fujitsu site to check for new updates for your system.

The FDU icon should appear in the system tray at the bottom right of your screen (roll the cursor over the icons to find the correct one). If the FDU icon does not appear in the system tray, it can be started by going to [Start] -> All Programs, and clicking on Fujitsu Driver Update; this will create the icon automatically.

To invoke the FDU menu, right-click on the FDU icon. The menu contains the following items:

Check for updates now

Allows for manual driver update search. The first time it is used, you are prompted to agree to a user agreement. After clicking on the icon, the FDU automatically connects with the Fujitsu site to check for updates and downloads them. While downloading, the icon has a red bar through it, indicating that it cannot be used while the download is in process. When the update is complete, a message appears informing you of the fact.

Enable Automatic Update Notifications

Automatically searches for new updates on a regular basis (approximately every 3 days).

Show update history

Brings up a screen that displays a history of updates that have been made via the FDU.

About Fujitsu Driver Update

Displays the FDU version number and copyright information

Fujitsu Driver Update Readme

Displays the FDU readme.

Chapter 3

System Specifications

Specifications

This section provides the hardware and environmental specifications for your Fujitsu Stylistic Tablet PC. Specifications of particular configurations will vary.

Configuration Label

The configuration label located on the back of your Tablet PC contains specific information regarding the options you've chosen for your Tablet PC. Following is an example configuration label.

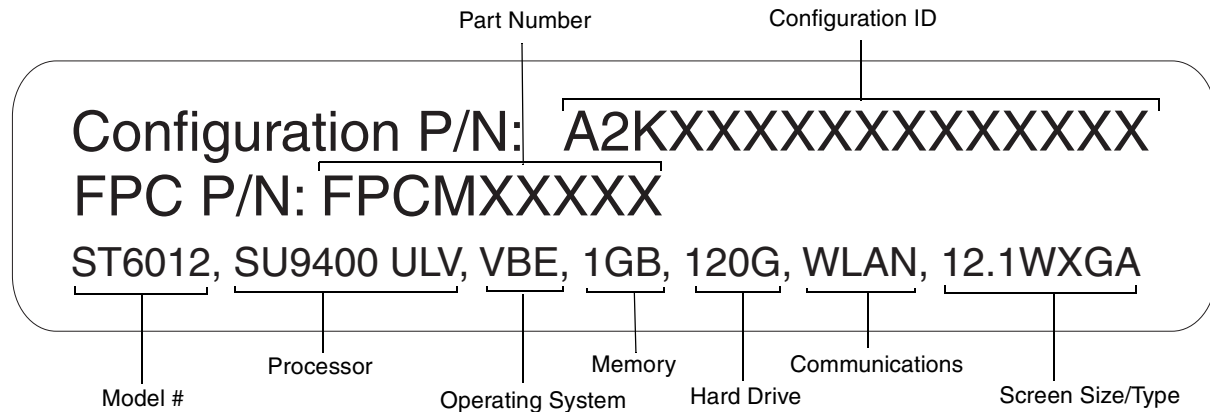

Microprocessor

Intel® Core™ 2 Duo Ultra Low Voltage processors (Refer to the system label to determine the speed of your processor).

Chipset

- Intel GS45
- I/O Controller Hub 9 Mobile (ICH9M-SFF-Enhanced)

Memory

System Memory

- DDR2-667 MHz SDRAM dual-channel memory module.
- Two DIMM slots; upgradeable to 4 GB of total memory (2 GB x 2). Note that when 4 MB of memory is installed in a Windows Vista system, approximately 3.3 GB is addressable memory; the upper memory is reserved by Vista for hardware usage.

Cache Memory

3 MB L2 cache on-die

Video

- Color flat-panel TFT active matrix LCD display with simultaneous display capability.
- Indoor/outdoor viewability

Video Color and Resolution

12.1" Crystal View Wide XGA display

- Internal: 1280 x 800 pixel resolution, 16M colors
- External: 1600 x 1200 pixel resolution, 16M colors
- Simultaneous: 1280 x 800, 16M colors

Video RAM

Intel® GS45 video graphics controller, with the following amounts of shared video memory using Dynamic Video Memory Technology (DVMT), as determined by the amount of system memory:

Operating System	System Memory	Maximum Graphics Memory
Windows Vista	1 GB	271 MB
	2 GB	783 MB
	3 GB	1295 MB
	4 GB	1295 MB
Windows XP	1 GB	512 MB
	2 GB	1024 MB
	3 GB	1024 MB
	4 GB	1024 MB

Audio

- Realtek codec ALC269
- **Headphones:** Stereo headphone jack, 3.5 mm, 1 V_{rms} or less, minimum impedance 32 Ohms
- **Microphone:** Stereo microphone jack, 3.5 mm, 100 mV_{p-p} or less, minimum impedance 10K Ohms
- One built-in speaker, 20 mm diameter
- Two built-in dual digital microphones

Mass Storage Device Options

Hard Drive Options

- Serial ATA, 150 Mbps data buffer, 5400 rpm, 2.5", 9.5 mm
- Serial ATA, 150 Mbps data buffer, 7200 rpm, 2.5", 9.5 mm
- MLC Solid State Drive, 64 GB, 2.5"
- Shock-mounted
- Shock Sensor utility

Communications

- **Gigabit LAN:** Internal wired 10/100/1000 Gigabit Ethernet LAN
- **WLAN:** Optional Integrated Intel Wireless WiFi Link 5300 (533AN_HMW), or, Atheros AR9280AL1E (AR5BHB92) Half Mini-Card Wireless network card
- **Bluetooth:** Bluetooth 2.1 device for wireless personal area network communication

Security Features

Trusted Platform Module

The Stylistic Tablet PC ST6010 has a Trusted Platform Module (TPM) installed for added system security.

Stylistic Security/Application Panel

Six Security/Application buttons, each with primary, secondary, and tertiary functions. For detailed information about the Security and Application buttons, refer to “Application, Navigation, and Security Buttons” on page 30 and “Security Functions of Application Buttons” on page 36.

Theft Prevention Lock

One lock slot for use with security restraint systems.

Fingerprint Recognition Sensor

Swipe sensor for biometric security.

Device Ports

On the Stylistic Tablet PC:

- PC Card slot for one Type I or Type II card: PCMCIA Standard 2.1 with CardBus support
- Memory Stick/SD Card slot
- One 15-pin D-SUB connector for VGA external monitor (see Display specifications)
- Two USB 2.0 (Universal Serial Bus) connectors for input/output devices
- One DC In connector
- One LAN (RJ-45) connector
- Docking port (100-pin, to dock with port replicator)
- One stereo headphone jack
- One stereo microphone jack
- Dedicated Smart Card slot (requires third-party application)
- IR port for external USB keyboard/mouse support
- IrDA port for communications

On the Optional Port Replicator:

- One 15-pin D-SUB connector for VGA external monitor
- Four USB 2.0 connectors for input/output devices
- One LAN (RJ-45) connector
- One DC-in connector
- One DVI-D connector
- One Headphone-Out connector

Power

Batteries

Standard Lithium ion battery, rechargeable, 6-cell 10.8V, 5800 mAh

AC Adapter

Autosensing 100-240V AC, supplying 16V DC, 3.75A, 60W to the Tablet PC; includes an AC cable

Power Management

Conforms to ACPI (Advanced Configuration and Power Interface).

Dimensions and Weight

Overall Dimensions

Approximately 11.69"(w) x 8.62"(d) x 1.34"(h) (297 mm x 219 mm x 34 mm)

Weight

Approximately 3.57 lbs. (1.62 kg) with 6-cell battery

Environmental Requirements

Temperature

Operating: 41° to 95° F (5° to 35° C). Non-operating: 5° to 140° F (–15° to 60° C)

Humidity

Operating: 20% to 85%, relative, non-condensing. Non-operating: 8% to 85%, relative, non-condensing

Altitude

Operating: 10,000 feet (3,048 m) maximum

Popular Accessories

For ordering or additional information on Fujitsu accessories please visit our Web site at www.shopfujitsu.com or call 1-800-FUJITSU.

Included Software

Depending on your pre-installed operating system, your Tablet PC comes with software for playing audio and video files of various formats. In addition there is file transfer software, virus protection software and Power Management software. The following list indicates the software included with your system.

- Acrobat Reader
- Norton Internet Security™ (90-day free trial)
- ArcSoft Webcam Companion 2
- Roxio Creator LJ (on select models)
- Google Desktop
- Google Tool Bar
- Google Picasa
- OmniPass Fingerprint application
- Fujitsu Driver Update utility
- Microsoft Office Ready 2007 (60-day free trial) with Activation Assistant
- Microsoft Office OneNote 2007 (on select models)
- Evernote 2.0 Plus

Learning About Your Software

Tutorials

All operating systems and most application software have tutorials built into them upon installation. We highly recommend that you step through the tutorial before you use an application.

Manuals

Included with your Tablet PC you will find manuals for your installed operating system and other pre-installed software. Any manuals that are not included, are available online through the help system of the software. We recommend that you review these manuals for general information on the use of these applications.

Acrobat Reader

The Acrobat Reader allows you to view, navigate, and print PDF files from across all of the major computing platforms.

ArcSoft Webcam Companion 2

WebCam Companion 2 offers a variety of webcam-optimized functions such as automatically recording movement detected by the cam, launching video chat sessions, capturing still and video images, and editing photos.

Norton Internet Security

Your system is preinstalled with a free 90-day trial version of Symantec's Norton Internet Security™. Norton Internet Security is a suite of tools designed to protect your Tablet PC from computer viruses, hackers, spyware, and spam. It assists in the protection of data currently on your hard disk from destruction or contamination. The trial version is activated upon your acceptance of software license agreement. After 90 days, you will need to purchase a subscription from Symantec to download latest virus, spyware, and spam definitions.

Roxio Creator LJ

(Available with some configurations of the optional port replicator) Creator LJ allows you to easily burn CDs and organize, edit and share digital photos, music, data, and videos.

OmniPass Fingerprint application

The fingerprint sensor uses Softex OmniPass which provides password management capabilities to Microsoft Windows operating systems. OmniPass lets you use a "master password" for all Windows, applications, and on-line passwords, and presents a convenient user interface through which you can securely manage passwords, users, and multiple identities for each user.

Google Desktop

Google Desktop lets you to search the contents of your computer for emails, web history, and files. It also allows you to view news and photos from anywhere on your desktop.

Google Picasa

Google Picasa lets you to search for, locate, move and label all of the photos on your computer.

Google Toolbar

Google Toolbar lets you to search the Internet quickly, block pop-ups, and perform a variety of other tasks to make your Internet experience easier and more pleasant.

Fujitsu Driver Update Utility

The Fujitsu Driver Update (FDU) utility is pre-installed on your system. With FDU, you can choose to automatically or manually go to the Fujitsu site to check for new updates for your system. See “Automatically Downloading Driver Updates” on page 117.

Microsoft OneNote

OneNote lets you collect all of your notes and information in an electronic “notebook” so that you can organize your pictures, text, notes, and audio/video files in a single, searchable place.

EverNote

EverNote allows you to easily capture, store and access a variety of documents, such as typed and handwritten memos, webpage excerpts, emails, phone messages, addresses, passwords, sketches, and documents.

Operating System Option

The following operating system configuration is installed on your system:

- **Microsoft Windows Vista Business Edition**
With Microsoft Office Ready and and Microsoft Office Activation Assistant
- [TBD - WINDOWS XP?](#)

Regulatory Information

Notice

Changes or modifications not expressly approved by Fujitsu could void this user's authority to operate the equipment.

FCC NOTICES

Notice to Users of Radios and Television

This equipment has been tested and found to comply with the limit for class B digital devices, pursuant to parts 15 of the FCC Rules.

These limits are designed to provide reasonable protection against harmful interference in a residential installation. This equipment generates, uses, and can radiate radio frequency energy and, if not installed and used in accordance with the instructions, may cause harmful interference to radio communications. However, there is no guarantee that interference will not occur in a particular installation. If this equipment does cause harmful interference to radio or television reception, which can be determined by turning the equipment off and on, the user is encouraged to try to correct the interference by one or more of the following measures:

- Reorient or relocate the receiving antenna.
- Increase the separation between the equipment and receiver.
- Connect the equipment into an outlet that is on a different circuit than the receiver.
- Consult the dealer or an experienced radio/TV technician for help.

Shielded interconnect cables must be employed with this equipment to ensure compliance with the pertinent RF emission limits governing this device.

Notice to Users of the US Telephone Network

This equipment complies with Part 68 of the FCC rules, and the requirements adopted by ACTA. On the bottom of this equipment is a label that contains, among other information, the FCC registration number and ringer equivalence number (REN) for this equipment; or a product identifier in the format US:AAAEQ##TXXXX. If requested, this information or number must be provided to the telephone company.

This equipment is designed to be connected to the telephone network or premises wiring using a standard jack type USOC RJ11C. A plug and jack used to connect this equipment to the premises wiring and telephone network must comply with the applicable FCC Part 68 rules and requirements adopted by the ACTA. A compliant telephone cord and modular plug is provided with this product. It is designed to be connected to a compatible modular jack that is also compliant.

The ringer equivalent number (REN) of this equipment is 0.1B as shown on the label. The REN is used to determine the number of devices that may be connected to a telephone line. Excessive RENs on a telephone may result in the devices not ringing in response to an incoming call. In most but not all areas, the sum of RENs should not exceed five (5.0). To be certain of the number of devices that may be connected to a line, as determined by the total RENs, contact the local telephone company.

If this equipment causes harm to the telephone network, the telephone company will notify you in advance that temporary discontinuance of service may be required. But if advance notice isn't practical, the telephone company will notify the customer as soon as possible. Also, you will be advised of your right to file a complaint with the FCC if you believe it is necessary.

The telephone company may make changes in its facilities, equipment, operations or procedures that could effect the operation of the equipment. If this happens the telephone company will provide advance notice in order for you to make necessary modifications to maintain uninterrupted service.

If trouble is experienced with this equipment, for repair or warranty information, please refer to the manual or contact Fujitsu Computer Systems Corporation, Customer Service. If the equipment is causing harm to the telephone network, the telephone company may request that you disconnect the equipment until the problem is resolved.

The equipment cannot be used on public coin service provided by the telephone company. Connection to party line service is subject to state tariffs. (Contact the state public utility commission, public service commission or corporation commission for information).

If your home has specially wired alarm equipment connected to the telephone line, ensure the installation of this computer does not disable your alarm equipment. If you have any questions about what will disable alarm equipment, consult your telephone company or a qualified installer.

The Telephone Consumer Protection Act of 1991 makes it unlawful for any person to use a computer or other electronic device to send any message via a telephone fax machine unless such message clearly contains in a margin at the top or bottom of each transmitted page or on the first page of the transmission, the date and time it is sent and an identification of the business or other entity, or other individual sending the message and the telephone number of the sending machine or such business, other entity, or individual.

DOC (INDUSTRY CANADA) NOTICES

Notice to Users of Radios and Television

This Class B digital apparatus meets all requirements of Canadian Interference-Causing Equipment Regulations.

CET appareil numérique de la class B respecte toutes les exigences du Règlement sur le matériel brouilleur du Canada.

Notice to Users of the Canadian Telephone Network

NOTICE: This equipment meets the applicable Industry Canada Terminal Equipment Technical Specifications. This is confirmed by the registration number. The abbreviation, IC, before the registration number signifies that registration was performed based on a Declaration of Conformity indicating that Industry Canada technical specifications were met. It does not imply that Industry Canada approved the equipment.

Before connecting this equipment to a telephone line the user should ensure that it is permissible to connect this equipment to the local telecommunication facilities. The user should be aware that compliance with the certification standards does not prevent service degradation in some situations.

Repairs to telecommunication equipment should be made by a Canadian authorized maintenance facility. Any repairs or alterations not expressly approved by Fujitsu or any equipment failures may give the telecommunication company cause to request the user to disconnect the equipment from the telephone line.

NOTICE: The Ringer Equivalence Number (REN) for this terminal equipment is 0.1B. The REN assigned to each terminal equipment provides an indication of the maximum number of terminals allowed to be connected to a telephone interface. The termination on an interface may consist of any combination of devices subject only to the requirement that the sum of the Ringer Equivalence Numbers of all the devices does not exceed five.



FOR SAFETY, USERS SHOULD ENSURE THAT THE ELECTRICAL GROUND OF THE POWER UTILITY, THE TELEPHONE LINES AND THE METALLIC WATER PIPES ARE CONNECTED TOGETHER. USERS SHOULD NOT ATTEMPT TO MAKE SUCH CONNECTIONS THEMSELVES BUT SHOULD CONTACT THE APPROPRIATE ELECTRIC INSPECTION AUTHORITY OR ELECTRICIAN. THIS MAY BE PARTICULARLY IMPORTANT IN RURAL AREAS.

Avis Aux Utilisateurs Du Réseau Téléphonique Canadien

AVIS: Le présent matériel est conforme aux spécifications techniques d'Industrie Canada applicables au matériel terminal. Cette conformité est confirmée par le numéro d'enregistrement. Le sigle IC, placé devant le numéro d'enregistrement, signifie que l'enregistrement s'est effectué conformément à une déclaration de conformité et indique que les spécifications techniques d'Industrie Canada ont été respectées. Il n'implique pas qu'Industrie Canada a approuvé le matériel.

Avant de connecter cet équipement à une ligne téléphonique, l'utilisateur doit vérifier s'il est permis de connecter cet équipement aux installations de télécommunications locales. L'utilisateur est averti que même la conformité aux normes de certification ne peut dans certains cas empêcher la dégradation du service.

Les réparations de l'équipement de télécommunications doivent être effectuées par un service de maintenance agréé au Canada. Toute réparation ou modification, qui n'est pas expressément approuvée par Fujitsu, ou toute défaillance de l'équipement peut entraîner la compagnie de télécommunications à exiger que l'utilisateur déconnecte l'équipement de la ligne téléphonique.

AVIS: L'indice d'équivalence de la sonnerie (IES) du présent matériel est de 0.1B. L'IES assigné à chaque dispositif terminal indique le nombre maximal de terminaux qui peuvent être raccordés à une interface téléphonique. La terminaison d'une interface peut consister en une combinaison quelconque de dispositifs, à la seule condition que la somme d'indices d'équivalence de la sonnerie de tous les dispositifs n'excède pas 5.



POUR ASSURER LA SÉCURITÉ, LES UTILISATEURS DOIVENT VÉRIFIER QUE LA PRISE DE TERRE DU SERVICE D'ÉLECTRICITÉ, LES LIGNES TÉLPHONIQUES ET LES CONDUITES D'EAU MÉTALLIQUES SONT CONNECTÉES ENSEMBLE. LES UTILISATEURS **NE DOIVENT PAS** TENTER D'ÉTABLIR CES CONNEXIONS EUX-MÊMES, MAIS DOIVENT CONTACTER LES SERVICES D'INSPECTION D'INSTALLATIONS ÉLECTRIQUES APPROPRIÉS OU UN ÉLECTRICIEN. CECI PEUT ÊTRE PARTICULIÈREMENT IMPORTANT EN RÉGIONS RURALES.



Appendix A: WLAN User's Guide

FC FCC Regulatory Information

Please note the following regulatory information related to the optional wireless LAN device.

Regulatory Notes and Statements

Wireless LAN, Health and Authorization for use

Radio frequency electromagnetic energy is emitted from Wireless LAN devices. The energy levels of these emissions, however, are far much less than the electromagnetic energy emissions from wireless devices such as mobile phones. Wireless LAN devices are safe for use by consumers because they operate within the guidelines found in radio frequency safety standards and recommendations. The use of Wireless LAN devices may be restricted in some situations or environments, such as:

- On board an airplane, or
- In an explosive environment, or
- In situations where the interference risk to other devices or services is perceived or identified as harmful.

In cases in which the policy regarding use of Wireless LAN devices in specific environments is not clear (e.g., airports, hospitals, chemical/oil/gas industrial plants, private buildings), obtain authorization to use these devices prior to operating the equipment.

Regulatory Information/Disclaimers

Installation and use of this Wireless LAN device must be in strict accordance with the instructions included in the user documentation provided with the product. Any changes or modifications made to this device that are not expressly approved by the manufacturer may void the user's authority to operate the equipment. The manufacturer is not responsible for any radio or television interference caused by unauthorized modification of this device, or the substitution or attachment of connecting cables and equipment other than those specified by the manufacturer. It is the responsibility of the user to correct any interference caused by such unauthorized modification, substitution or attachment. The manufacturer and its authorized resellers or distributors will assume no liability for any damage or violation of government regulations arising from failure to comply with these guidelines.

This device must not be co-located or operated in conjunction with any other antenna or transmitter.

For IEEE 802.11a Wireless LAN: For operation within 5.15~5.25 GHz frequency range, it is restricted to indoor environments, and the antenna of this device must be integral.

Federal Communications Commission statement

This device complies with Part 15 of FCC Rules.

Operation is subject to the following two conditions: (1) This device may not cause interference, and, (2) This device must accept any interference, including interference that may cause undesired operation of this device.

FCC Interference Statement

This equipment has been tested and found to comply with the limits for a Class B digital device, pursuant to Part 15 of the FCC Rules. These limits are designed to provide reasonable protection against harmful interference in a residential installation. This equipment generates, uses, and can radiate radio frequency energy. If not installed and used in accordance with the instructions, it may cause harmful interference to radio communications. However, there is no guarantee that interference will not occur in a particular installation.

If this equipment does cause harmful interference to radio or television reception, which can be determined by turning the equipment off and on, the user is encouraged to try and correct the interference by one or more of the following measures:

- 1 Reorient or relocate the receiving antenna.
- 2 Increase the distance between the equipment and the receiver.
- 3 Connect the equipment to an outlet on a circuit different from the one the receiver is connected to.
- 4 Consult the dealer or an experienced radio/TV technician for help.

FCC Radio Frequency Exposure statement

The available scientific evidence does not show that any health problems are associated with using low power wireless devices. There is no proof, however, that these low power wireless devices are absolutely safe. Low power wireless devices emit low levels of radio frequency energy (RF) in the microwave range while being used. Whereas high levels of RF can produce health effects (by heating tissue), exposure to low-level RF that does not produce heating effects causes no known adverse health effects. Many studies of low-level RF exposure have not found any biological effects. Some studies have suggested that some biological effects might occur, but such findings have not been confirmed by additional research. The wireless LAN radio device has been tested and found to comply with FCC radiation exposure limits set forth for an uncontrolled equipment and meets the FCC radio frequency (RF) Exposure Guidelines in Supplement C to OET65.

Export restrictions

This product or software contains encryption code which may not be exported or transferred from the US or Canada without an approved US Department of Commerce export license. This device complies with Part 15 of FCC Rules., as well as ICES 003 B / NMB 003 B. Operation is subject to the following two conditions: (1) this device may not cause harmful interference, and (2) this device must accept any interference received, including interference that may cause undesirable operation. Modifications not expressly authorized by Fujitsu Computer Systems Corp. may invalidate the user's right to operate this equipment.

Canadian Notice

The device for the 5150 - 5250 MHz band is only for indoor usage to reduce the potential for harmful interference to co-channel mobile satellite systems.

The maximum antenna gain of 6 dBi permitted (for devices in the 5250 - 5350 MHz, 5470 - 5725 MHz and 5725 - 5825 MHz bands) to comply with the e.i.r.p. limit as stated in A9.2 of RSS210.

In addition, users are cautioned to take note that high power radars are allocated as primary users (meaning they have priority) of 5250 - 5350 MHz and 5650 - 5850 MHz and these radars could cause interference and/or damage to LE-LAN devices.

Before Using the Optional Wireless LAN

This manual describes the procedures required to properly set up and configure the optional integrated Wireless LAN Mini-PCI device (referred to as "WLAN device" in the rest of the manual). Before using the WLAN device, read this manual carefully to ensure its correct operation. Keep this manual in a safe place for future reference.

Wireless LAN Device Covered by this Document

This document is applicable to systems containing one of the following optional devices:

- Intel Wireless WiFi Link 5300 (533AN_HMW)
- Atheros AR9280AL1E (AR5BHB92) Half Mini-Card Wireless network card

Characteristics of the WLAN Device

- The WLAN devices are Mini-PCI card attached to the main board of the mobile computer.
- The WLAN devices operate in license-free RF bands, eliminating the need to procure an FCC operating license. The WLANs operate in the 2.4GHz Industrial, Scientific, and Medical (ISM) RF band and the lower, middle, and upper bands of the 5GHz Unlicensed National Information Infrastructure (UNII) bands.
- The wireless devices are capable of four operating modes, IEEE802.11a, IEEE802.11b, IEEE802.11g, and IEEE802.11n (draft)
- The WLAN devices are Wi-Fi certified and operate (as applicable) at a the maximum data rate of 540 Mbps (theoretical) in IEEE802.11n (draft) mode; 54 Mbps in IEEE802.11a or IEEE802.11g mode; and 11 Mbps in IEEE802.11b mode.
- The WLAN devices support the following encryption methods - WEP, TKIP, CKIP, and AES encryption.
- The Wireless LAN devices are compliant with the following standards: WPA, WPA2, CCX1.0, CCX2.0, CCX3.0, and CCX4.0.

Wireless LAN Modes Using this Device

Ad Hoc Mode

"Ad Hoc Mode" refers to a wireless network architecture where wireless network connectivity between multiple computers is established without a central wireless network device, typically known as Access Point(s). Connectivity is accomplished using only client devices in a peer-to-peer fashion. That is why Ad Hoc networks are also known as peer-to-peer networks. Ad Hoc networks are an easy and inexpensive method for establishing network connectivity between multiple computers. Ad Hoc mode requires that the SSID, network authentication, and encryption key settings are identically configured on all computers in the Ad Hoc network.

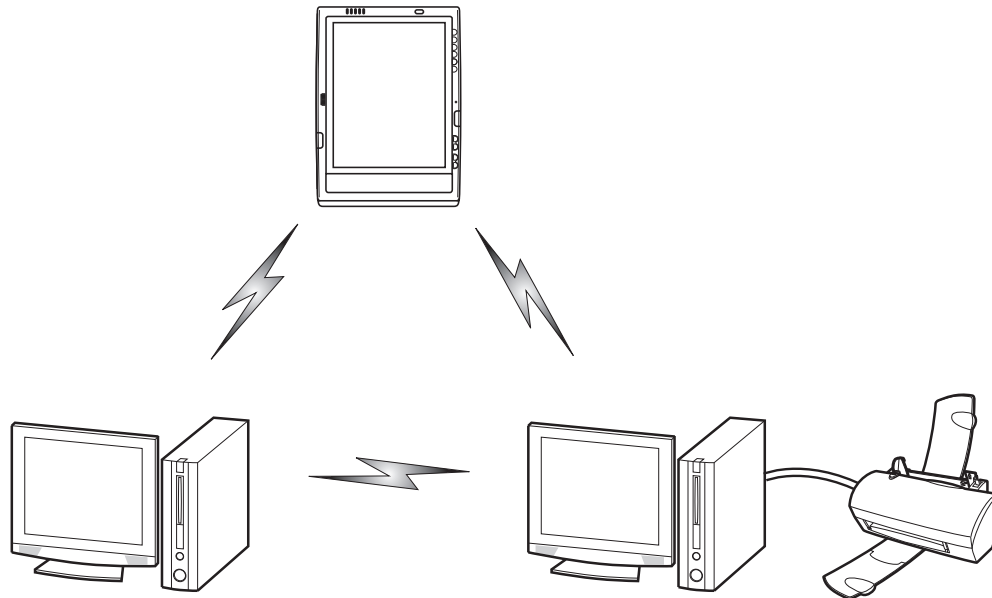

Figure 21. Ad Hoc Mode Network

Access Point (Infrastructure) Mode

Infrastructure mode refers to a wireless network architecture in which devices communicate with wireless or wired network devices by communicating through an Access Point. In infrastructure mode, wireless devices can communicate with each other or with a wired network. Corporate wireless networks operate in infrastructure mode because they require access to the WLAN in order to access services, devices, and computers (e.g., file servers, printers, databases).

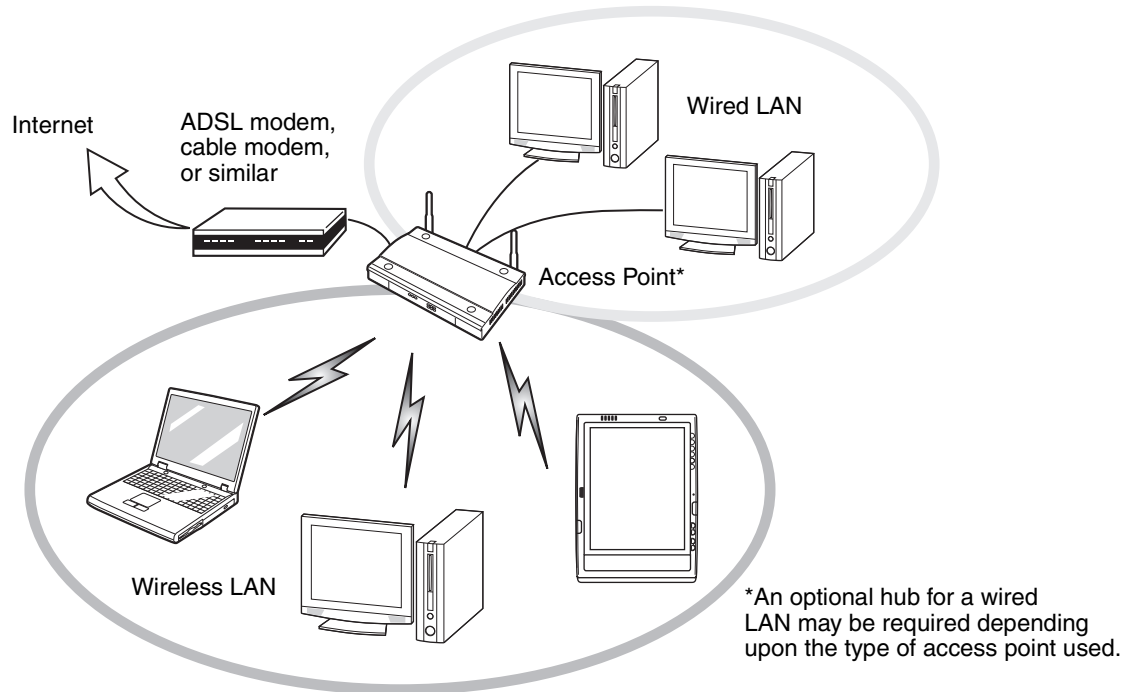

Figure 22. Access Point (Infrastructure) Mode Network

How to Handle This Device

The WLAN device is an optional device that may come pre-installed in your mobile computer. Under normal circumstances, it should not be necessary for you to remove or re-install it. The operating system that your mobile computer comes with has been pre-configured to support the WLAN device.

- The wireless devices support IEEE802.11a, IEEE802.11b, IEEE802.11g, and IEEE802.11n.
- The WLAN devices operate in the 2.4 GHz ISM band and the 5 GHz lower, middle, and upper UNII bands.
- Microwave ovens may interfere with the operation of WLAN devices since they operate in the same 2.4 GHz frequency range as IEEE802.11b/g/n devices. Interference by microwaves does not occur with IEEE802.11a radio which operates in the 5 GHz RF band.
- Wireless devices that transmit in the 2.4 GHz range may interfere with operation of WLAN devices in IEEE802.11b/g/n modes. Symptoms of interference include reduced throughput, intermittent disconnects, and many frame errors. It is HIGHLY recommended that these interfering devices be powered off to ensure proper operation of the WLAN device.

Deactivating/Disconnecting the WLAN Device

Disconnecting the WLAN device may be desired in certain circumstances (to extend battery life) or where certain environments require it (i.e. hospitals, clinics, airplanes, etc.). The WLAN device can be deactivated by using the Wireless On/Off Switch, and it can be disconnected in Windows using the WLAN icon in the system tray (Note that disconnecting via the icon in the system tray does not turn off the radio; it continues to transmit and receive even though it's not connected.).



BEFORE USING THE WIRELESS LAN DEVICE, YOU MUST FIRST INSTALL CLICKME! TO ENSURE THAT THE CORRECT SOFTWARE FOR YOUR DEVICE IS INSTALLED. SEE "INSTALLING CLICKME!" ON PAGE 70.

Deactivation Using the Wireless On/Off Switch

The WLAN device can be deactivated quickly and efficiently by toggling the Wireless LAN/Bluetooth On/Off Switch to the Off position. The switch has no effect on non-Wireless LAN models.

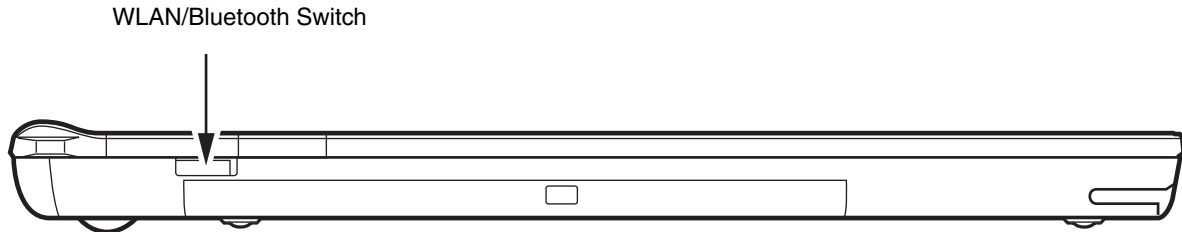

Figure 23. Wireless LAN/Bluetooth On/Off Switch Location

Disconnection Using the Icon in the Taskbar

Note that disconnecting via the icon in the system tray does not turn off the radio; it continues to transmit and receive even though it's not connected.

- 1 Right-click the WLAN icon in the taskbar at the bottom right of your screen.
- 2 Choose Disconnect from a network.

Activating the WLAN Device

Activation of the WLAN device can be accomplished using the same methods as the deactivation process

- Using the Wireless On/Off Switch
- In Windows, by right-clicking the WLAN icon then clicking "Connect to a network"

Configuring the Wireless LAN

The optional WLAN device can be configured to establish wireless network connectivity using the software that is built into Windows Vista. Support for most industry standard security solutions is contained in this software.

Pre-defined parameters will be required for this procedure. Please consult with your network administrator for these parameters:

Configuring the WLAN Using Windows Vista

- 1 Click the Start button, then select Control Panel.
- 2 If the Control Panel is not in Classic View, select Classic View from the left panel. Double-click the Network and Sharing Center icon.
- 3 Select “Manage wireless networks” from the left panel.
- 4 Click on the [Add] button.
- 5 Depending upon what type of connection you would like to make, make a selection. For an infrastructure network, select “Manually create a network profile. For ad hoc network, select “Create an ad hoc network”.
- 6 Enter the required information. It may be necessary to consult with your network administrator for some of the information.
- 7 In the event you require assistance, go to the Network and Sharing Center window (Start -> Control Panel -> Network and Sharing Center), and type in relevant keywords in the Search box.

Connecting to a Network

After you have configured your computer, you can connect to an active network by performing the following steps:

- 1 Click on the WLAN icon in the system tray.
- 2 Select “Connect to a network”.
- 3 Select a network from the list that appears, and click the [Connect] button.

Configuring the WLAN Using Windows XP

Procedure

- 1 Click the Start button, then select Control Panel.
- 2 If the Control Panel is not in Classic View, select Classic View from the left panel. Double-click the Network Connections icon.
- 3 Select “New Connection” wizard.
- 4 Click the [Next] button.
- 5 Select “Connect to the Internet”, then click [Next].
- 6 Depending upon what type of connection you would like to make, make a selection. For an infrastructure network, select “Manually create a network profile. For ad hoc network, select “Choose from a list of Internet service providers”.
- 7 Enter any required information. It may be necessary to consult with your network administrator for some of the information.
- 8 In the event you require assistance, go to [Start] -> Help and Support -> Networking and the Web. Select the main topic in which you are interested, then type in relevant keywords in the Search box.

Connection to the network

After you have configured your computer, you can connect to an active network by clicking on the Wireless Network icon in the system tray:

Troubleshooting the WLAN

Troubleshooting

Causes and countermeasures for troubles you may encounter while using your wireless LAN are described in the following table. If you are unfamiliar with the steps required, consult your System Administrator or go to [Start] -> Help and Support -> Networking and the Web

Problem	Possible Cause	Possible Solution
Unavailable network connection	Incorrect network name (SSID) or network key	<p>Ad hoc connection: verify that the network names (SSID's) and network keys (WEP) of all computers to be connected have been configured correctly. SSID's and WEP key values must be identical on each machine.</p> <p>Access Point (Infrastructure) connection: set network name (SSID) and network key to the same values as those of the access point.</p> <p>Set the Network Authentication value identically to that of the Access Point. Please consult your network administrator for this value, if necessary.</p>
	Weak received signal strength and/or link quality	<p>Ad hoc connection: Retry connection after shortening the distance to the destination computer or removing any obstacles for better sight.</p> <p>Access Point (Infrastructure) connection: Retry connection after shortening the distance to the access point or removing any obstacles for better sight.</p>
	The WLAN device has been deactivated or disabled	<p>Check if the wireless switch is turned On. In Windows XP, go to Start -> Control Panel-> Network Connections and right-click on Wireless Network Connection. If Enable appears at the top of the menu, click it to enable the device. In Windows Vista, go to Start -> Control Panel, and double-click on Windows Mobility Center. If the wireless network is off, click the [Turn wireless on] button..</p>

Problem	Possible Cause	Possible Solution
Unavailable network connection (continued)	The computer to be connected is turned off	Check if the computer to be connected is turned ON.
	RF interference from Access Points or other wireless networks	The use of identical or overlapping RF channels can cause interference with the operation of the WLAN device. Change the channel of your Access Point to a channel that does not overlap with the interfering device.
	Wireless network authentication has failed	Re-check your Network Authentication, Encryption, and Security settings. Incorrectly configured security settings such as an incorrectly typed WEP key, a mis-configured LEAP username, or an incorrectly chosen authentication method will cause the LAN device to associate but not authenticate to the wireless network.
	Incorrectly configured network settings	Recheck the configuration of your network settings.
	Incorrect IP address configuration	This only applies to networks using static IP addresses. Please contact your network administrator for the correct settings.

WLAN Specifications

Specifications

Item	Specification
Type of network	The Intel WiFi Link 5300 (533AN_HMW) and Atheros AR9280AL1E (AR5BHB92) Half Mini-Card Wireless network card conform to IEEE 802.11a, 802.11b/g, and 802.11n (draft-compliant), Wi-Fi based*.
Transfer rate	(Automatic switching) 54 Mbps maximum data rate (IEEE802.11n to be determined)
Active frequency	<ul style="list-style-type: none"> • 802.11n (draft): 2.4 GHz or 5 GHz • 802.11b/g: 2400~2473 MHz • 802.11a: 4900 ~ 5850 MHz
Typical operating distances**	<ul style="list-style-type: none"> • 802.11a: 40 ft. (12 m) @ 54 Mbps; 300 ft. (91 m) @ 6 Mbps • 802.11b: 100 ft. (30 m) @ 11 Mbps; 300 ft. (91 m) @ 1 Mbps • 802.11g: 100 ft. (30 m) @ 54 Mbps; 300 ft. (91 m) @ 1 Mbps • 802.11n (draft): Estimated double the operating distance of 802.11g and 802.11a in their respective frequencies.
Number of channels	<ul style="list-style-type: none"> • 802.11a: 8 independent channels • 802.11b/g: 11 channels, 3 non-overlapping channels • 802.11n (draft): 2.4 GHz - 3 non-overlapping channels when Channel Bonding is not used; 2 non-overlapping channels when Channel Bonding is used. 5 GHz - 12 non-overlapping UNII channels with or without Channel Bonding
Security	Encryption Types - WEP, TKIP, AES***, WPA 1.0 compliant Encryption Key lengths Supported: 64 bits and 128 bits 802.1x/EAP
Maximum recommended number of computers to be connected over wireless LAN (during ad hoc connection)	10 units or less ****

- * “Wi-Fi based” indicates that the interconnectivity test of the organization which guarantees the interconnectivity of wireless LAN (Wi-Fi Alliance) has been passed.
- ** The communication ranges shown above will increase or decrease depending on factors such as number of walls, reflective material, or interference from external RF sources.
- *** Encryption with network key (WEP) is performed using the above number of bits, however, users can set 40 bits/ 104 bits after subtracting the fixed length of 24 bits.
- **** Depending on practical environments, the allowable number of computers to be connected may be decreased.

Using the Bluetooth Device

The Integrated Bluetooth module (EYTF3CSFT) is an optional device available for Fujitsu mobile computers.

What is Bluetooth?

Bluetooth technology is designed as a short-range wireless link between mobile devices, such as laptop computers, phones, printers, and cameras. Bluetooth technology is used to create Personal Area Networks (PANs) between devices in short-range of each other.



THE WIRELESS LAN/BLUETOOTH ON/OFF SWITCH WILL POWER OFF BOTH THE OPTIONAL WIRELESS LAN AND BLUETOOTH DEVICES AT THE SAME TIME. TO ENABLE OR DISABLE EITHER ONE OF THE DEVICES INDIVIDUALLY, PERFORM THE FOLLOWING STEPS:

- 1 Slide the Wireless LAN/Bluetooth on/off switch to On position.
- 2 In the Control Panel, click the button associated with Bluetooth and/or Wireless LAN Status to enable or disable the individual devices.
- 3 Click [OK].

Where to Find Information About Bluetooth

The Bluetooth module contains a robust Help user's guide to assist you in learning about operation of the Bluetooth device.

Windows XP: To access the Help file, click [Start] -> All Programs, and click on Toshiba. Select Bluetooth, then select User's Guide.

Windows Vista: o access the Help file, click [Start] -> All Programs, and click on Bluetooth, then select User's Guide.

For additional information about Bluetooth Technology, visit the Bluetooth Web site at: www.bluetooth.com.

FCC Radiation Exposure Statement

This equipment complies with FCC radiation exposure limits set forth for an uncontrolled environment. The Bluetooth antenna is located on the front edge of the right palm rest and is exempt from minimum distance criteria due to its low power.

The transmitters in this device must not be co-located or operated in conjunction with any other antenna or transmitter.

Canadian Notice

To prevent radio interference to the licensed service, this device is intended to be operated indoors and away from windows to provide maximum shielding. Equipment (or its transmit antenna) that is installed outdoors is subject to licensing.

Warranty

Users are not authorized to modify this product. Any modifications invalidate the warranty.

This equipment may not be modified, altered, or changed in any way without signed written permission from Fujitsu. Unauthorized modification will void the equipment authorization from the FCC and Industry Canada and the warranty.

Appendix B: Fingerprint Sensor Device

Introducing the Fingerprint Sensor Device

Your system has a fingerprint sensor device at the top left of the display screen (when holding the display in portrait mode).

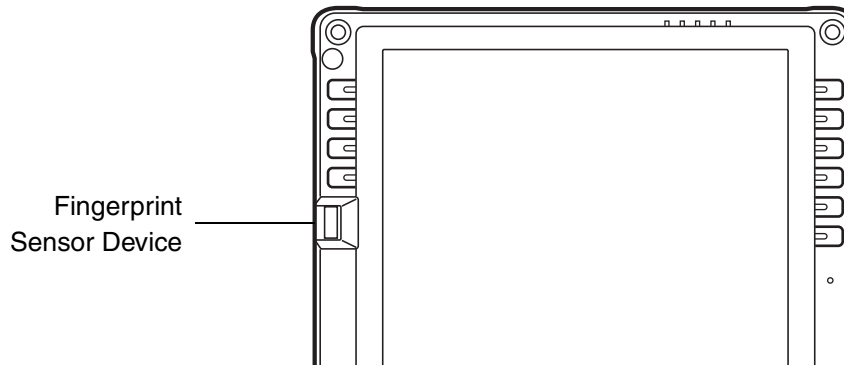

Figure 24. Fingerprint sensor

With a fingerprint sensor, you can avoid having to enter a username and password every time you want to:

- Log onto Windows
- Resume from sleep mode
- Cancel a password-protected screen saver
- Log into homepages that require a username and password

After you have “enrolled” - or registered - your fingerprint, you can simply swipe your fingertip over the sensor for the system recognize you.

The fingerprint sensor uses Softex OmniPass which provides password management capabilities to Microsoft Windows operating systems. OmniPass enables you to use a "master password" for all Windows, applications, and on-line passwords.

OmniPass requires users to authenticate themselves using the fingerprint sensor before granting access to the Windows desktop. This device results in a secure authentication system for restricting access to your computer, applications, web sites, and other password-protected resources.

OmniPass presents a convenient graphical user interface, through which you can securely manage passwords, users, and multiple identities for each user.



CERTAIN MODELS SUPPORT PRE-BOOT AUTHENTICATION OR PBA. PBA ALLOWS THE USER TO LOG IN PRIOR TO WINDOWS' OWN AUTHENTICATION MECHANISM. A PBA ENVIRONMENT SERVES AS AN EXTENSION OF THE BIOS OR BOOT FIRMWARE AND ALLOWS FOR A MORE SECURE ENVIRONMENT EXTERNAL TO THE OPERATING SYSTEM.

Getting Started

This section guides you through the preparation of your system for the OmniPass fingerprint recognition application. You will be led through the OmniPass installation process. You will also be led through the procedure of enrolling your first user into OmniPass.

Installing OmniPass

If OmniPass has already been installed on your system, skip this section and go directly to “User Enrollment” on page 120. You can determine whether OmniPass has already been installed by checking to see if the following are present:

- The gold key-shaped OmniPass icon in the system tray at the bottom right of the screen.
- The Softex program group in the **Programs** group of the **Start** menu

System Requirements

The OmniPass application requires space on your hard drive; it also requires specific Operating Systems (OS's). The minimum requirements are as follows:

- Windows XP Professional or Windows Vista operating system
- At least 35 MB available hard disk space

Installing the OmniPass Application

If OmniPass is already installed on your system, go to “User Enrollment” on page 120. Otherwise continue with this section on software installation.



- INSTALLATION OF THE APPLICATION REQUIRES THAT YOU HAVE AN EXTERNAL OPTICAL DRIVE ATTACHED TO YOUR SYSTEM.
- FOR INSTALLATION, OMNIPASS REQUIRES THAT THE USER INSTALLING OMNIPASS HAVE ADMINISTRATIVE PRIVILEGES TO THE SYSTEM. IF YOUR CURRENT USER DOES NOT HAVE ADMINISTRATIVE PRIVILEGES, LOG OUT AND THEN LOG IN WITH AN ADMINISTRATOR USER BEFORE PROCEEDING WITH OMNIPASS INSTALLATION.

To install OmniPass on your system you must:

- 1** Insert the installation media for the OmniPass application into the appropriate drive. If you are installing from CD-ROM or DVD-ROM, you must find and launch the OmniPass installation program (setup.exe) from the media.
- 2** Follow the directions provided in the OmniPass installation program. Specify a location to which you would like OmniPass installed. It is recommended that you NOT install OmniPass in the root directory (e.g. C:\).
- 3** Once OmniPass has completed installation you will be prompted to restart you system. Once your system has rebooted you will be able to use OmniPass. If you choose not to restart immediately after installation, OmniPass will not be available for use until the next reboot.
- 4** The installation program automatically places an icon (Softex OmniPass) in the Windows Control Panel as well as a golden key shaped icon in the taskbar.

Verifying Information about OmniPass

After you have completed installing OmniPass and restarted your system, you may wish to check the version of OmniPass on your system.

To check the version information of OmniPass:

- 1** From the Windows Desktop, double-click the key-shaped OmniPass icon in the taskbar (usually located in the lower right corner of the screen),
or,
Click the **Start** button, select **Settings**, and click **Control Panel** (if you are using Windows XP you will see the Control Panel directly in the Start menu; click it, then click **Switch to Classic View**). Double-click **Softex OmniPass** in the Control Panel, and the OmniPass Control Center will appear. If it does not appear, then the program is not properly installed,
or,
Click the **Start** button, select **Programs**, and from the submenu select the **Softex** program group, from that submenu click **OmniPass Control Center**.
- 2** Select the **About** tab at the top of the OmniPass Control Panel. The About tab window appears with version information about OmniPass.

Uninstalling OmniPass



FOR UNINSTALLATION, OMNIPASS REQUIRES THAT THE USER UNINSTALLING OMNIPASS HAVE ADMINISTRATIVE PRIVILEGES TO THE SYSTEM. IF YOUR CURRENT USER DOES NOT HAVE ADMINISTRATIVE PRIVILEGES, LOG OUT AND THEN LOG IN WITH AN ADMINISTRATOR USER BEFORE PROCEEDING WITH OMNIPASS UNINSTALLATION.

To remove the OmniPass application from your system:

- 1** Click **Start** on the Windows taskbar. Select **Settings**, and then **Control Panel**.
- 2** Double-click **Add/Remove Programs**.
- 3** Select **OmniPass**, and then click **Change/Remove**.

- 4 Follow the directions to uninstall the OmniPass application.
- 5 Once OmniPass has finished uninstalling, reboot your system when prompted.

User Enrollment

Before you can use any OmniPass features you must first enroll a user into OmniPass.

Master Password Concept

Computer resources are often protected with passwords. Whether you are logging into your computer, accessing your email, e-banking, paying bills online, or accessing network resources, you often have to supply credentials to gain access. This can result in dozens of sets of credentials that you have to remember.

During user enrollment a "master password" is created for the enrolled user. This master password "replaces" all other passwords for sites you register with OmniPass.

Example: A user, John, installs OmniPass on his system (his home computer) and enrolls an OmniPass user with username "John_01" and password "freq14". He then goes to his webmail site to log onto his account. He inputs his webmail credentials as usual (username "John_02" and password "Tablet PC"), but instead of clicking [Submit], he directs OmniPass to **Remember Password**. Now whenever he returns to that site, OmniPass will prompt him to supply access credentials.

John enters his OmniPass user credentials ("John_01" and "freq14") in the OmniPass authentication prompt, and he is allowed into his webmail account. He can do this with as many web sites or password protected resources he likes, and he will gain access to all those sites with his OmniPass user credentials ("John_01" and "freq14"). This is assuming he is accessing those sites with the system onto which he enrolled his OmniPass user. OmniPass does not actually change the credentials of the password protected resource. If John were to go to another computer without he OmniPass account to access his webmail, he would need to enter his original webmail credentials ("John_02" and "Tablet PC") to gain access. If he attempts his OmniPass user credentials on a system other than a system he's enrolled on, he will not gain access.



THE ENROLLMENT PROCEDURE ASSUMES YOU HAVE NO HARDWARE AUTHENTICATION DEVICES OR ALTERNATE STORAGE LOCATIONS THAT YOU WISH TO INTEGRATE WITH OMNIPASS. IF YOU DESIRE SUCH FUNCTIONALITY, CONSULT THE APPROPRIATE SECTIONS OF THIS DOCUMENT.

Basic Enrollment

The Enrollment Wizard will guide you through the process of enrolling a user. Unless you specified otherwise, after OmniPass installation the Enrollment Wizard will launch on Windows login. If you do not see the Enrollment Wizard, you can bring it up by clicking **Start** on the Windows taskbar; select **Programs**; select **Softex**; click **OmniPass Enrollment Wizard**.

- 1** Click **Enroll** to proceed to username and password verification. By default, the OmniPass Enrollment Wizard enters the credentials of the currently logged in Windows user.
- 2** Enter the password you use to log in to Windows. This will become the “master password” for this OmniPass user. In most cases, the **Domain:** value will be your Windows computer name. In a corporate environment, or when accessing corporate resources, the **Domain:** may not be your Windows computer name. Click [Next] to continue.
- 3** In this step OmniPass captures your fingerprint. Refer to “Enrolling a Fingerprint” on page 122 for additional information.
- 4** Next, choose how OmniPass notifies you of various events. We recommend you keep **Taskbar Tips** on **Beginner mode taskbar tips** and **Audio Tips** on at least **Prompt with system beeps only** until you get accustomed to how OmniPass operates. Click [Next] to proceed with user enrollment. You will then see a Congratulations screen indicating your completion of user enrollment.
- 5** Click [Done] to exit the OmniPass Enrollment Wizard. You will be asked if you’d like to log in to OmniPass with your newly enrolled user; click [Yes].

Enrolling a Fingerprint

Enrolling a fingerprint will increase the security of your system and streamline the authentication procedure.

You enroll fingerprints in the OmniPass Control Center. With an OmniPass user logged in, double-click the system tray OmniPass icon. Select the **User Settings** tab and click **Enrollment** under the **User Settings** area. Click **Enroll Authentication Device** and authenticate at the authentication prompt to start device enrollment.

- 1** During initial user enrollment, you will be prompted to select the finger you wish to enroll. Fingers that have already been enrolled will be marked by a green check. The finger you select to enroll at this time will be marked by a red arrow. OmniPass will allow you re-enroll a finger. If you choose a finger that has already been enrolled and continue enrollment, OmniPass will enroll the fingerprint, overwriting the old fingerprint. Select a finger to enroll and click [Next].
- 2** It is now time for OmniPass to capture your selected fingerprint. It may take a several capture attempts before OmniPass acquires your fingerprint. Should OmniPass fail to acquire your fingerprint, or if the capture screen times out, click [Back] to restart the fingerprint enrollment process.

Your system has a “swipe” fingerprint sensor. A swipe sensor is small and resembles a skinny elongated rectangle. To capture a fingerprint, gently swipe or pull your fingertip over the sensor (starting at the second knuckle) **towards yourself**. Swiping too fast or too slow will result in a failed capture. The **Choose Finger** screen has a [Practice] button; click it to practice capturing your fingerprint. When you are comfortable with how your fingerprint is captured, proceed to enroll a finger.

- 3** Once OmniPass has successfully acquired the fingerprint, the **Verify Fingerprint** screen will automatically appear. To verify your enrolled fingerprint, place your fingertip on the sensor and hold it there as if you were having a fingerprint captured. Successful fingerprint verification will show a green fingerprint in the capture window and the text **Verification Successful** under the capture window.
- 4** After you are done enrolling and verifying your fingerprints, you will have the option to **Enable PBA with enrolled finger**. If you enable this option, then you must choose two fingers to save in PBA. If you have enrolled successfully, the **Finger Enrollment Status in PBA** screen will state Finger saved in PBA successfully.



IF YOU ENABLE PBA ON YOUR SYSTEM, YOU MUST SET THE SUPERVISOR PASSWORD AND PASSWORD ON BOOT SETTINGS. SEE “SETTING THE SUPERVISOR PASSWORD AND PASSWORD ON BOOT SETTINGS” ON PAGE 66 FOR ADDITIONAL INFORMATION.

Using OmniPass

You are now ready to begin using OmniPass. Used regularly, OmniPass will streamline your authentications.

Password Replacement

You will often use the password replacement function. When you go to a restricted access website (e.g., your bank, your web-based email, online auction or payment sites), you are always prompted to enter your login credentials. OmniPass can detect these prompts and you can teach OmniPass your login credentials. The next time you go to that website, you can authenticate with your fingerprint to gain access.

OmniPass Authentication Toolbar

After installing OmniPass and restarting, you will notice a dialog you have not seen before at Windows Logon. This is the OmniPass Authentication Toolbar, and it is displayed whenever the OmniPass authentication system is invoked. The OmniPass authentication system may be invoked frequently: during Windows Logon, during OmniPass Logon, when unlocking your workstation, when resuming from sleep or hibernate, when unlocking a password-enabled screensaver, during password replacement for remembered site or application logins, and more. When you see this toolbar, OmniPass is prompting you to authenticate.

The **Logon Authentication** window indicates what OmniPass-restricted function you are attempting. The icons in the lower left (fingerprint and key) show what authentication methods are available to you. Selected authentication methods are highlighted while unselected methods are not. When you click the icon for an unselected authentication method, the authentication prompt associated with that method is displayed.

When prompted to authenticate, you must supply the appropriate credentials: an enrolled finger for the fingerprint capture window or your master password for the master password prompt (the key icon).

Remembering a Password

OmniPass can remember any application, GUI, or password protected resource that has a password prompt.

Using the following procedure, you can store a set of credentials into OmniPass. These credentials will then be linked to your “master password” or fingerprint.

Go to a site that requires a login (username and password), but *do not log in yet*. At the site login prompt, enter your username and password in the prompted fields, but *do not enter the site* (do not hit [Enter], [Submit], [OK], or Login). Right-click the OmniPass system tray icon and select **Remember Password** from the submenu. The Windows arrow cursor will change to a golden key OmniPass cursor. Click the OmniPass cursor in the login prompt area, but don’t click [Login] or [Submit].

Associating a Friendly Name

After clicking the OmniPass key cursor near the login prompt, OmniPass will prompt you to enter a “friendly name” for this site. You should enter something that reminds you of the website, the company, or the service you are logging into. In its secure database, OmniPass associates this friendly name with this website.

Additional Settings for Remembering a Site

When OmniPass prompts you to enter a “friendly name” you also have the opportunity to set how OmniPass authenticates you to this site. There are three effective settings for how OmniPass handles a remembered site.

The default setting is **Automatically click the “OK” or “Submit” button for this password protected site once the user is authenticated**. With this setting, each time you navigate to this site OmniPass will prompt you for your master password or fingerprint authentication device. Once you have authenticated with OmniPass, you will automatically be logged into the site.

Less secure is the option to **Automatically enter this password protected site when it is activated. Do not prompt for authentication.** Check the upper box to get this setting, and each time you navigate to this site OmniPass will log you into the site without prompting you to authenticate.



THIS SETTING IS MORE CONVENIENT IN THAT WHENEVER YOU GO TO A SITE REMEMBERED WITH THIS SETTING, YOU WILL BYPASS ANY AUTHENTICATION PROCEDURE AND GAIN INSTANT ACCESS TO THE SITE. BUT SHOULD YOU LEAVE YOUR SYSTEM UNATTENDED WITH YOUR OMNIPASS USER LOGGED IN, ANYONE USING YOUR SYSTEM CAN BROWSE TO YOUR PASSWORD PROTECTED SITES AND GAIN AUTOMATIC ACCESS.

If you uncheck both boxes in **Settings for this Password Site**, OmniPass will prompt you for your master password or fingerprint authentication device. Once you have authenticated with OmniPass your credentials will be filled in to the site login prompt, but you will have to click the website [OK], [Submit], or [Login] button to gain access to the site.

Click **Finish** to complete the remember password procedure. The site location, the credentials to access the site, and the OmniPass authentication settings for the site are now stored in the OmniPass secure database. The OmniPass authentication settings (**Settings for this Password Site**) can always be changed in **Vault Management**.

Logging in to a Remembered Site

Whether or not OmniPass prompts you to authenticate when you return to a remembered site is determined by **Settings for this Password Site** and can be changed in **Vault Management**.

The following cases are applicable to using OmniPass to login to: Windows, remembered web sites, and all other password protected resources.

With Master Password

Once you return to a site you have remembered with OmniPass, you may be presented with a master password prompt. Enter your master password and you will be allowed into the site.

Logging into Windows with a Fingerprint Device

When logging into Windows with a fingerprint device, the fingerprint capture window will now appear next to the Windows Login screen. Place your enrolled fingertip on the sensor to authenticate. You will be simultaneously logged into Windows and OmniPass. The capture window will also appear if you have used **Ctrl-Alt-Del** to lock a system, and the fingerprint device can be used to log back in as stated above.



IF A MACHINE IS LOCKED AND OMNIPASS DETECTS A DIFFERENT USER LOGGING BACK IN WITH A FINGERPRINT, THE FIRST USER WILL BE LOGGED OUT AND THE SECOND USER LOGGED IN.

In Windows XP, your login options must be set either for classic login, or for fast user switching and logon screen to be enabled to use your fingerprint to log on to Windows. To change this go to **Control Panel**, select **User Accounts** and then click **Change the way users log on or off**. If your Windows screensaver is password protected, the fingerprint capture window will now appear next to screensaver password dialog during resume. You can authenticate to your screensaver password prompt with your enrolled finger.

Password Management

OmniPass provides an interface that lets you manage your passwords. To access this GUI, double-click the OmniPass key in the system tray. Click **Vault Management**; you will be prompted to authenticate. Once you gain access to **Vault Management**, click **Manage Passwords** under **Vault Settings**. You will see the **Manage Passwords** interface, with a list of friendly names.

You can view the credentials stored for any remembered website by highlighting the desired resource under **Password Protected Dialog** and clicking **Unmask Values**. Should a password be reset, or an account expire, you can remove stored credentials from OmniPass. Highlight the desired resource under **Password Protected Dialog** and click **Delete Page**. You will be prompted to confirm the password deletion.

The two check boxes in **Manage Passwords** govern whether OmniPass prompts you to authenticate or directly logs you into the remembered site.

OmniPass will overwrite an old set of credentials for a website if you attempt to use **Remember Password** on an already remembered site.

The exception to the above rule is when resetting the Windows password. If your password is reset in Windows, the next time you login to Windows, OmniPass will detect the password change and prompt you to “Update” or “Reconfirm” the password with OmniPass. Enter your new Windows password in the prompt and click **OK**. Your OmniPass "master password" will still be your Windows password.

OmniPass User Identities

Identities allow OmniPass users to have multiple accounts to the same site (e.g., *bob@biblomail.com* and *boballen@biblomail.com*). If OmniPass did not provide you identities, you would be limited to remembering one account per site.

To create and manage identities, double-click the OmniPass key in the system tray. Click **Vault Management**; OmniPass will prompt you to authenticate. Once you gain access to **Vault Management**, click **Manage Identities** under **Vault Settings**. You can only manage the identities of the currently logged in OmniPass user

To add a new identity, click **New Identity** or double-click **Click here to add a new identity**. Name the new identity and click [OK], then click [Apply]. You can now switch to the new identity and start remembering passwords.

To delete an identity, highlight the identity you want to delete and click [Delete Identity], then click [Apply].



WHEN YOU DELETE AN IDENTITY, ALL OF ITS ASSOCIATED REMEMBERED SITES AND PASSWORD PROTECTED DIALOGS ARE LOST.

To set the default identity, highlight the identity you want as default and click [Set as Default]; click [Apply] to ensure the settings are saved. If you log in to OmniPass with a fingerprint device, you will automatically be logged in to the default identity for that OmniPass user. You can choose the identity with which you are logging in if you login using "master password".

Choosing User Identity during Login

To choose your identity during login, type your username in the **User Name:** field. Press [Tab] and see that the **Domain:** field self-populates. Click the **Password:** field to bring the cursor to it, and you will see the pull-down menu in the **Identity:** field. Select the identity to login as, then click **OK**.

Switch User Identity

To switch identities at any time, right-click the OmniPass system tray icon and click **Switch User Identity** from the submenu. The **Switch Identity** dialog will appear. Select the desired identity and then click **OK**.

Identities and Password Management

On the **Manage Passwords** interface of the **Vault Management** tab of the OmniPass Control Center, there is a pull-down selection box labeled, **Identity**. This field lets you choose which identity you are managing passwords for. When you select an identity here, only those password protected dialogs that are associated with that identity are shown. You can perform all the functions explained in “Password Management” on page 126.

Configuring OmniPass

This section gives an overview of both the Export/Import function and the OmniPass Control Center.

Exporting and Importing Users



YOU CANNOT IMPORT A USER INTO OMNIPASS IF THERE ALREADY IS A USER WITH THE SAME NAME ENROLLED IN OMNIPASS.

Using OmniPass Control Center, you can export and import users in and out of OmniPass. The export process backs up all remembered sites, credentials, and enrolled fingerprints for an OmniPass user. All OmniPass data for a user is backed up to a single encrypted database file. During the import process, the Windows login of the exported user is required. If the proper credentials cannot be supplied, the user profile will not be imported.



- YOU SHOULD PERIODICALLY EXPORT YOUR USER PROFILE AND STORE IT IN A SAFE PLACE. IF ANYTHING HAPPENS TO YOUR SYSTEM, YOU CAN IMPORT YOUR OMNIPASS PROFILE TO A NEW SYSTEM AND HAVE ALL YOUR REMEMBERED SETTINGS AND FINGERPRINTS INSTANTLY.
- YOU DON'T FORGET THE WINDOWS LOGIN CREDENTIALS WHEN EXPORTING. WHEN YOU EXAMINE THE IMPORTATION, YOU ARE PROMPTED FOR AUTHENTICATION. THE CREDENTIALS THAT WILL ALLOW A USER PROFILE TO BE IMPORTED ARE THE WINDOWS LOGIN CREDENTIALS OF THE EXPORTED USER. THEY ARE THE CREDENTIALS THAT HAD TO BE SUBMITTED WHEN THE USER PROFILE WAS EXPORTED. YOU WILL NEED USER NAME, PASSWORD, AND DOMAIN.

Exporting an OmniPass User Profile

To export a user, open the OmniPass Control Center, and click **Import/Export User** under **Manage Users**.

Click **Exports an OmniPass user profile**. OmniPass will prompt you to authenticate. Upon successfully authentication, you must name the OmniPass user profile and decide where to save it. An .opi file is generated, and you should store a copy of it in a safe place.

This .opi file contains all your user specific OmniPass data, and it is both encrypted and password protected. This user profile does NOT contain any of your encrypted data files.

Importing an OmniPass User Profile

To import an OmniPass user open the OmniPass Control Center, and click **Import/Export User** under **Manage Users**. Click **Imports** a new user into OmniPass and then select **OmniPass Import/Export File (*.opi)** and click **Next**. OmniPass will then prompt you to browse for the file you had previously exported (.opi file). When you select the .opi file for importation, OmniPass will prompt you for authentication.

The credentials that will allow a user profile to be imported are the Windows login credentials of the exported user. They are the credentials that had to be submitted when the user profile was exported. You will need User Name, Password, and Domain. If you don't remember the value for Domain, in a PC or SOHO environment Domain should be your computer name.

OmniPass will notify you if the user was successfully imported.

Things to Know Regarding Import/Export

- Assume you export a local Windows User profile from OmniPass. You want to import that profile to another machine that has OmniPass. Before you can import the profile, a Windows user with the same login credentials must be created on the machine importing the profile.

Example: I have a Windows user with the username "Tom" and the password "Sunshine" on my system. I have enrolled Tom into OmniPass and remembered passwords. I want to take all my passwords to new system. I export Tom's OmniPass user profile. I go to my new system and using the Control Panel I create a user with the username "Tom" and the password "Sunshine". I can now successfully import the OmniPass user data to the new system.

- If you export an OmniPass-only user, you can import that user to any computer running OmniPass, provided that a user with that name is not already enrolled in OmniPass.
- If you attempt to import a user profile who has the same name as a user already enrolled in OmniPass, the OmniPass import function will fail.

OmniPass Control Center

This section will serve to explain functions within the OmniPass Control Center that weren't explained earlier.

You can access the OmniPass Control Center any of three ways:

- Double-click the golden OmniPass key shaped icon in the Windows taskbar (typically in the lower-right corner of the desktop)

- Click the **Start** button; select the **Programs** group; select the **Softex** program group; and click the **OmniPass Control Center** selection.
- Open the Windows **Control Panel** (accessible via **Start** button --> **Settings** --> **Control Panel**) and double-click the **Softex OmniPass** icon.

User Management

The User Management tab has two major interfaces: **Add/Remove User** and **Import/Export User**. Import/Export User functionality is documented in “Exporting and Importing Users” on page 128. Add/Remove User functionality is straightforward.

If you click **Adds a new user to OmniPass** you will start the OmniPass Enrollment Wizard. The Enrollment Wizard is documented in “User Enrollment” on page 120.

If you click **Removes a user from OmniPass**, OmniPass will prompt you to authenticate. Authenticate with the credentials (or enrolled fingerprint) of the user you wish to remove. OmniPass will prompt you to confirm user removal. Click **OK** to complete user removal.



REMOVING A USER WILL AUTOMATICALLY DESTROY ALL OMNIPASS DATA ASSOCIATED WITH THAT USER. ALL IDENTITIES AND CREDENTIALS ASSOCIATED WITH THE USER WILL BE LOST.

IF YOU'RE SURE YOU WANT TO REMOVE THE USER, WE RECOMMEND YOU EXPORT THE USER PROFILE.

User Settings

The User Settings tab has four interfaces: **Audio Settings**, **Taskbar Tips**, and **Enrollment**. User settings allow users to customize OmniPass to suit their individual preferences. Under **User Settings (Audio Settings and Taskbar Tips)** you can set how OmniPass notifies the user of OmniPass events (e.g., successful login, access denied, etc.). The details of each setting under the **Audio Settings** and **Taskbar Tips** interfaces are self-explanatory.

The **Enrollment** interface allows you to enroll fingerprints. For the procedure to enroll and authentication device refer to *Chapter 2.3*. To enroll additional fingerprints, click **Enroll Authentication Device**, and authenticate with OmniPass. Select the fingerprint recognition device in the **Select Authentication Device** screen (it should already be marked by a green check if you have a finger enrolled) and click **Next**.

System Settings

The OmniPass **Startup Options** interface can be found in the System Settings tab. With these options you can specify how your OmniPass Logon is tied to your Windows Logon.

The first option, **Automatically log on to OmniPass as the current user**, will do just as it says; during Windows login, you will be logged on to OmniPass using your Windows login credentials. If the user logging into Windows was never enrolled into OmniPass, upon login no one will be logged on to OmniPass. This setting is appropriate for an office setting or any setting where users must enter a username and password to log into a computer. This is the default setting.

With the second option, **Manually log on to OmniPass at startup**, OmniPass will prompt you to login once you have logged on to Windows.

With the third option, **Do not log on to OmniPass at startup**, OmniPass will not prompt for a user to be logged on.

You can manually log on to OmniPass by right-clicking the OmniPass taskbar icon and clicking **Log in User** from the right-click menu.

Troubleshooting

You cannot use OmniPass to create Windows users. You must first create the Windows user, and you will need administrative privileges to do that. Once the Windows user is created, you can add that user to OmniPass using the same username and password

Cannot add Windows users to OmniPass

If you experience difficulties adding a Windows user to OmniPass, you may need to adjust your local security settings. You can do this by going to **Start, Control Panel, Administrative Tools, and Local Security Settings**. Expand **Local Policies**, expand **Security Options**, and double-click **Network Access: Sharing and Security Model for Local Accounts**. The correct setting should be *Classic - Local Users Authenticate as Themselves*.

Cannot add a User with a Blank Password to OmniPas

If you experience difficulties adding a user with a blank password to OmniPass, you may need to adjust your local security settings. First attempt the procedure explained in the *Cannot add Windows user to OmniPass* section. If the difficulties persist, then try the following procedure.

Click **Start, Control Panel, Administrative Tools, and Local Security Settings**. Expand **Local Policies**, expand **Security Options**, and double-click **Accounts: Limit local account use of blank passwords to console login only**. This setting should be set to Disabled.

Dialog appears after OmniPass authentication during Windows Logon

After installing OmniPass on your system, you can choose to logon to Windows using OmniPass. You authenticate with OmniPass (via master password, or an enrolled security device) and OmniPass logs you into Windows. You may, during this OmniPass authentication, see a **Login Error** dialog box.

This dialog box occurs when OmniPass was unable to log you into Windows with the credentials supplied (username and password). This could happen for any of the following reasons:

- Your Windows password has changed
- Your Windows account has been disabled

If you are having difficulties due to the first reason, you will need to update OmniPass with your changed Windows account password. Click **Update Password** and you will be prompted with a dialog to reconfirm your password.

Enter the new password to your Windows user account and click **OK**. If the error persists, then it is unlikely the problem is due to your Windows user account password changing.

Index

A

- About This Guide 1, 14
- adjusting the display brightness 60
- air flow vents 23
- application buttons 19
 - application A 32
 - application B 32
 - Ctl-Alt-Del button 31
 - display mode button 31
 - E-Mail 31
 - enter button 32
 - escape button 32
 - Fujitsu Menu Utility 32
 - function button 32
 - Internet 31
 - orientation button 31
 - security button 31
 - tertiary functions 34, 36
- Automatically Downloading Driver Updates 84

B

- battery gauge 66
- battery gauge icon 54
- battery icon 28
- battery pack
 - charging 66
 - critically low level 55
 - low-battery warning 55

- no memory effect 66
 - overcharge protection 66
 - removing and installing 66, 67
 - will not begin charging 66
- battery power
 - conserving 68
 - used in Standby mode 55
- battery release latch 21, 45
- BIOS 34
 - application buttons, for 34, 36
- Bluetooth
 - Where to Find Information 114
- BOOT Priority Change 83
- bridge battery 68
- built-in microphone 19

C

- calibrating the pen 64
- charge/DC input icon 28
- charging the battery pack 66
- cleaning the display screen 78
- Click Me! 42
- Configuration Label 86
- configuring peripherals interface 81
- connectors and peripheral interfaces 43
- conserving battery power 68
- Contact Information 15
- conventions used in the guide 14

critically low battery level 55

cursor

not tracking pen 79

D

DC input connector 25, 43

display

screen is blank 79

screen, cleaning 78

Drivers and Application Restore CD 81

E

external monitor connector 24

F

FDU 43, 84, 94

Fingerprint Sensor Device 116

enrolling a fingerprint 122

getting started 117

installing OmniPass 117

logging into a remembered site 125

OmniPass authentication toolbar 123

password replacement 123

remembering a password 124

uninstalling OmniPass 119

user enrollment 120

using OmniPass 123

fingerprint sensor device 19

Fujitsu Contact Information 15

Fujitsu Driver Update utility 43, 84, 94

Fujitsu Shopping Online 16

H

hard disk drive access icon 29

headphone 24

headphone jack 43

Hibernate (Save-to-Disk) mode 54, 56

Hibernate mode 47

I

idle state 47

infrared data transfer not working 80

infrared keyboard port 19

infrared keyboard/mouse port 44

Installing a Memory Stick 69

interfaces

connectors and peripherals 43

IrDA/FIR port 44

L

LAN jack 25

Local Area Network (LAN) 44

Lock 44

low-battery warning 55

M

memory cover 20

Memory Stick 23

installing 69

microphone 25

microphone jack 43

Microsoft Works 94

modem

connection 69

N

navigation buttons 19, 33

O

Off state 47, 53

overheating, avoiding 78

P

- page up/page down 44
- PC Card eject button 23
- PC card slot 43, 71
- PC Cards
 - removing 70
- pen 23, 26
 - installing a pen tether 64
 - not responding 80
 - replacing the tip 65
 - using 62
- pen tether 64
- pen tether point 23
- peripheral connectors 43
- power icon 29, 47
 - blinking 48, 54
 - not displayed 48
- power on/suspend/resume button 23
- power usage 46
- powering up the pen tablet 49
- Pre-Installed Software 92
 - Adobe Acrobat Reader 93
 - Google Toolbar 93, 94
 - manuals 92
- problems, solving 79
- protecting the display screen 75

R

- Registration 52
- Regulatory Information 95
- removable battery pack 21
- removing a Memory Stick 70
- restoring the factory image 82
- restoring your pre-installed software 81

- resuming system operation 56, 79
- RJ-45 44

S

- SD Card
 - removing 70
- SD Card slot 43
- SD Card/Memory Stick Slot 23
- Secure Digital Card
 - removing 70
- Security 25
- Security Application Panel
 - operating 39
 - passwords 37
 - uninstalling 40
- Setting up Security Panel 36
- Shock Sensor Utility 58
- shutting down the system 53
- Smart Card slot 23
- solving problems 79
- speaker 19
- speaker/headphone volume too low 80
- Specifications 86
 - Audio 88
 - Chipset 87
 - Device Ports 90
 - Dimensions and Weight 91
 - Environmental Requirements 91
 - mass storage device options 89
 - Memory 87
 - Microprocessor 87
 - Power 91
 - Video 87
- status display 27
 - battery icon 28

- charge/DC input icon 28
- hard disk drive access icon 29
- power icon, blinking 48
- power icon, system states indicated by 29, 47
- storing the system unit 77
- Stylistic ST5000
 - features 20, 22, 24, 26
 - storing 77
- suspend mode, determining 54
- Suspend/Resume
 - disabled 55
- Suspend/Resume button 44
- suspending system operation 53
- Suspend-to-RAM
 - mode 54, 56
- system interface connector 21
- system states 46, 47
 - Idle state 47
 - Off state 47
 - On state 46
 - Sleep Mode 47
- system status LEDs 19
- system will not resume operation 79

T

- Tablet Dock latch point 21
- Tablet Dock port 44
- tertiary functions of application buttons 34, 36
- thermal suede 21
- troubleshooting 79
- turning off the system 53

U

- Universal Serial Bus 24
- USB ports 24, 43
- using the pen 62

W

- Warranty 16
- Windows Vista
 - configuring the WLAN 108
- Windows XP
 - configuring the Wireless LAN 109
- Windows XP Tablet PC Edition 14, 17
- Wireless LAN
 - Before Using the Wireless LAN 103
 - configuring 103
 - connection to the network 109
 - deactivating/disconnecting 106
 - modes 104
 - Specifications 112
 - Troubleshooting 110
- wireless LAN 21
- wireless LAN/Bluetooth on/off switch 21, 45