

STANDARD Micro Controller Specification

N010-0559-V051 PS/2 Interface Controller Chip

(Summary Sheet)

FID-554 4-Wire Series

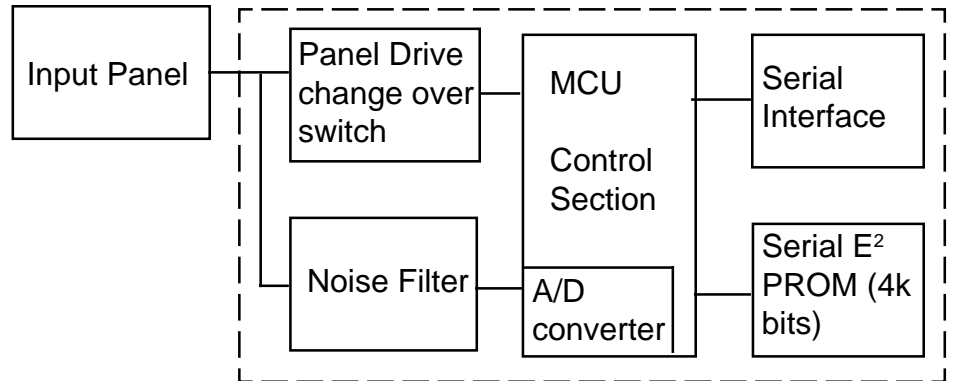

■ FEATURES

- High quality and reliability touch panel micro
- PS/2 Interface
- Supplied in boxes of 1600 pieces
- Used to control the FID-554 4-Wire series touch panel

■ CONSTRUCTION

- 64 pin PQFP MCU with masked ROM

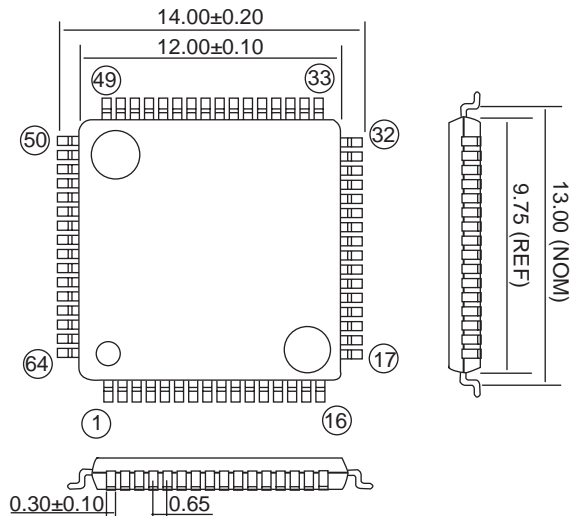

| | | | | | | | |
|----|--------|----|--------|----|--------|----|--------|
| 1 | Unused | 17 | Unused | 33 | Unused | 49 | Vss |
| 2 | S/P* | 18 | Unused | 34 | Unused | 50 | EROMCS |
| 3 | EMSR0 | 19 | *RST | 35 | Unused | 51 | Unused |
| 4 | EMSR1 | 20 | MOD0 | 36 | Unused | 52 | EROMS1 |
| 5 | EMSR2 | 21 | MOD1 | 37 | Unused | 53 | EROMS0 |
| 6 | EMSR3 | 22 | X0 | 38 | Unused | 54 | EROMCK |
| 7 | Unused | 23 | X1 | 39 | Unused | 55 | RXD |
| 8 | Unused | 24 | Vss | 40 | Unused | 56 | Vcc |
| 9 | Unused | 25 | Unused | 41 | *PSW0 | 57 | TXD |
| 10 | Unused | 26 | Unused | 42 | Unused | 58 | UCK1 |
| 11 | Avcc | 27 | Unused | 43 | Unused | 59 | UCK2 |
| 12 | AVR | 28 | Unused | 44 | Unused | 60 | Unused |
| 13 | Avss | 29 | PSW4 | 45 | Unused | 61 | Unused |
| 14 | CSEL | 30 | *PSW3 | 46 | Unused | 62 | Unused |
| 15 | *PINT | 31 | PSW2 | 47 | Unused | 63 | OS1 |
| 16 | *RXINT | 32 | *PSW1 | 48 | Unused | 64 | OS0 |

PS/2 Interface Controller Chip

■ PART NUMBER OF COMPLETE CHIP SPECIFICATION

| Part Number | Number of Pages | Full Technical Documentation Reference |
|----------------|-----------------|--|
| N010-0559-V051 | 34 | Tech Bes N-28748 |

Fujitsu Components International Headquarter Offices

Japan

Fujitsu Component Limited
Gotanda-Chuo Building
3-5, Higashigotanda 2-chome, Shinagawa-ku
Tokyo 141, Japan
Tel: (81-3) 5449-7010
Fax: (81-3) 5449-2626
Email: promothq@ft.ed.fujitsu.com
Web: www.fcl.fujitsu.com

North and South America

Fujitsu Components America, Inc.
250 E. Caribbean Drive
Sunnyvale, CA 94089 U.S.A.
Tel: (1-408) 745-4900
Fax: (1-408) 745-4970
Email: marcom@fcai.fujitsu.com
Web: www.fcai.fujitsu.com

Europe

Fujitsu Components Europe B.V.
Diamantlaan 25
2132 WV Hoofddorp
Netherlands
Tel: (31-23) 5560910
Fax: (31-23) 5560950
Email: info@fceu.fujitsu.com
Web: www.fceu.fujitsu.com

Asia Pacific

Fujitsu Components Asia Ltd.
102E Pasir Panjang Road
#04-01 Citilink Warehouse Complex
Singapore 118529
Tel: (65) 375-8560
Fax: (65) 273-3021
Email: fcal@fcal.fujitsu.com
www.fcal.fujitsu.com

© 2002 Fujitsu Components America, Inc. All company and product names are trademarks or registered trademarks of their respective owners. Rev. 03/2002