

General Inquiries <docomo Information Center>

☎ 0120-005-250 (toll free)

* Service available in: English, Portuguese, Chinese, Spanish, Korean.
* Available from mobile phones and PHSs.

■ From DOCOMO mobile phones (In Japanese only) ■ From land-line phones (In Japanese only)

☎ (No prefix) 151 (toll free) ☎ 0120-800-000 (toll free)

* Unavailable from land-line phones, etc. * Available from mobile phones and PHSs.

● Please confirm the phone number before you dial.

● For Applications or Repairs and After-Sales Service, please contact the above-mentioned information center or the docomo shop etc. near you on the NTT DOCOMO website or the i-mode site
▶ NTT DOCOMO website <http://www.nttdocomo.co.jp/english/> ▶ i-mode site iMenu⇒お客様サポート (user support)⇒ドコモショップ (docomo Shop) * In Japanese only

Loss or theft of FOMA terminal or payment of cumulative cost overseas <docomo Information Center>

(available 24 hours a day)

■ From DOCOMO mobile phones

International call access code for the country you stay (table 1) -81-3-5366-3114* (toll free)

* You are charged a call fee to Japan when calling from a land-line phone, etc.
※If you use F-03A, you should dial the number +81-3-5366-3114 (to enter '+', press and hold the '0' key for at least one second).

■ From land-line phones <Universal number>

International prefix number for the universal number (table 2) -800-0120-0151*

* You might be charged a domestic call fee according to the call rate for the country you stay.
※See page XXX for international call access codes for major countries (table 1) and international prefix numbers for the universal number (table 2).

● If you lose your FOMA terminal or have it stolen, immediately take the steps necessary for suspending the use of the FOMA terminal.
● If the FOMA terminal you purchased is damaged, bring your FOMA terminal to a repair counter specified by DOCOMO after returning to Japan.



Li-ion 00

To prevent damage to the environment, bring used battery packs to a docomo service counter, a docomo agent or a recycle center.



This manual is printed using an ink based on soy bean oil.



Don't forget your mobile phone ... or your manners!
When using your mobile phone in a public place, don't forget to show common courtesy and consideration for others around you.

Repairs

■ From DOCOMO mobile phones (In Japanese only) ■ From land-line phones (In Japanese only)

☎ (No prefix) 113 (toll free) ☎ 0120-800-000 (toll free)

* Unavailable from land-line phones, etc. * Available from mobile phones and PHSs.

Failures encountered overseas <Network Technical Operation Center>

(available 24 hours a day)

■ From DOCOMO mobile phones

International call access code for the country you stay (table 1) -81-3-6718-1414* (toll free)

* You are charged a call fee to Japan when calling from a land-line phone, etc.
※If you use F-03A, you should dial the number +81-3-6718-1414 (to enter '+', press and hold the '0' key for at least one second).

■ From land-line phones <Universal number>

International prefix number for the universal number (table 2) -800-5931-8600*

* You might be charged a domestic call fee according to the call rate for the country you stay.
※See page XXX for international call access codes for major countries (table 1) and international prefix numbers for the universal number (table 2).

Sales: NTT DOCOMO, INC.
Manufacturer: FUJITSU LIMITED

2009.1 (1st Edition)
CA92002-5481

docomo

F-03A

INSTRUCTION MANUAL

'09.1

docomo PRIME series F-03A

ISSUE DATE: '09.1

NAME:

PHONE NUMBER:

MAIL ADDRESS:

INSTRUCTION MANUAL

NTT docomo

Easy Search/Contents/Precautions	■■■■
Before Using the Handset	■■■■
Voice/Videophone Calls/PushTalk	■■■■
Phonebook	■■■■
Sound/Screen/Light Settings	■■■■
Security Settings	■■■■
Mail	■■■■
i-mode/i-motion/i-Channel/i-concier	■■■■
Full Browser	■■■■
Camera	■■■■
1Seg	■■■■
Music	■■■■
i-appli/i-Widget	■■■■
Osaifu-Keitai/ToruCa	■■■■
Map/GPS Function	■■■■
Data Management	■■■■
Convenient Functions	■■■■
Character Entry	■■■■
Network Services	■■■■
Overseas Use	■■■■
PC Connection	■■■■
Appendix/Troubleshooting	■■■■
Index/Quick Manual	■■■■

DOCOMO W-CDMA, GSM/GPRS System

Thank you for purchasing "docomo PRIME series F-03A" mobile terminal.

Before and during use of your FOMA terminal, be sure to thoroughly read this manual and instruction manuals that come with other optional devices to ensure you are able to correctly use your FOMA terminal. For more detailed information, contact "General Inquiries" using the phone number on the back of this manual. F-03A is your capable partner. Please treat it with care and enjoy using it for years.

Before using your FOMA terminal

- Because your FOMA terminal uses wireless transmission, it may not function in locations where it is difficult for radio waves to penetrate, such as tunnels, underground passages and some buildings, in areas where radio waves are weak, or out of service area. Even when you are high up in a tall building or condominium and nothing blocks your view outside, your FOMA terminal may not be able to receive or transmit signals. Also, communication may be interrupted even when the signal meter on your FOMA terminal indicates there are strong radio waves and you are not moving (traveling).
- Use your FOMA terminal in a way that does not disturb others in public spaces, crowded locations or quiet places.
- Because your FOMA terminal uses radio waves to communicate, it is possible that a third party may attempt to tap your calls. However, the W-CDMA, GSM/GPRS system automatically applies a confidential communication function to all calls, so even if a third party could somehow tap a call, they only hear noise.
- Your FOMA terminal encodes voice communication as digital data. When you are operating your FOMA terminal while moving to a location subject to weaker radio wave conditions, the transmitted digital data may not be correctly decoded and as a result the decoded voice may differ somewhat from the actual voice.
- Maintain a separate record of the data (Phonebook, Schedule, Notepad, Recorded messages, Voice memos, Movie memo, etc.) you registered in your FOMA terminal. Note that DOCOMO assumes no responsibility for any loss of saved contents of data resulting from malfunction, repair, changing of the model or other handling of FOMA terminal.
- You are recommended to save important data to microSD card. Using DOCOMO keitai datalink, you can transfer and save phonebook, mail, schedule and other data to a PC.

- The user hereby agrees that the user shall be solely responsible for the result of the use of SSL. Neither DOCOMO nor the certifier as listed herein makes any representation and warranty as for the security in the use of SSL. If the data should be erased, DOCOMO assumes no responsibility for the loss of any data. Certifier : VeriSign Japan K.K., Cybertrust Japan Co., Ltd., GlobalSign K.K., RSA Security Japan Ltd., SECOM Trust Systems Co., Ltd., Comodo CA Ltd.
- This FOMA terminal supports FOMA Plus-Area and FOMA HIGH-SPEED Area.
- FOMA terminal can be used only via the FOMA network provided by DOCOMO and DOCOMO's roaming area.

Before using this manual

This FOMA terminal supports Kisekai Tool (→P94). When changing the design of the menu screen using Kisekai Tool, the structure of some menus may be changed according to the usage frequency depending on the menu type. Also, the number assigned to menu item (item number) may not be applicable to some menu items.

Latest information about this manual can be downloaded from NTT DOCOMO website.

- User's Manual Download
<http://www.nttdocomo.co.jp/english/support/manual/index.html>

* The URL and contents are subject to change without prior notice.

Viewing/Searching this manual

This manual provides the methods below for necessary function's easy search.

Searching from Easy Search ▶ P4

Search for frequently used or convenient functions by plain words.

Searching from Menu list ▶ P386

Search from menu displayed on the display of F-03A.

Searching from thumb indices ▶ Front cover

Search from the index on the front cover.

*See P2-3 for examples.

Searching from Contents ▶ P6

Search from Contents categorized into chapters by functions.

Searching by main functions ▶ P8

Search from featured functions or new functions of F-03A.

Searching from the Index ▶ P2

Search from the function name, item keyword or service name.

Using the Quick Manual ▶ P2

You can cut out Quick Manual from this manual and carry it with you anywhere.

Also refer to described "Quick Manual (Overseas Use)" when using FOMA terminal overseas.

- In this "Manual for F-03A", "F-03A" mobile terminal is usually referred to as "FOMA terminal". Please be forewarned.
- This manual explains functions performed with a microSD card. A microSD card is required separately.
microSD card→P298
- The images or illustration used in this manual are examples. They may differ from the actual displays.
- The icons and screens that appear on the display have been initialized to the default settings selected from the combinations prepared in FOMA terminal depending on FOMA terminal color.
This manual mainly gives descriptions assuming that Kisekai Tool is set to "White".→P94
- In this manual, "i-appli compatible with Osaifu-Keitai which supports IC card function" is referred to as "Osaifu-Keitai compatible i-appli".
- The description of "authenticate" indicates the operating procedure for entering the terminal security code (4-8 digits).→P102
- Unauthorized copying of parts of or this entire manual is prohibited.
- The contents of this manual are subject to change without prior notice.

Viewing/Searching this manual

Methods to search pages are described, taking "Answer machine" for example.

Searching from Easy Search

Functions frequently used and convenient functions are categorized by their purposes and with simple words.

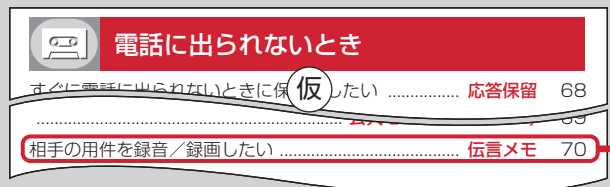

Searching from Menu list

Functions can be searched from the words displayed on the FOMA terminal screen.

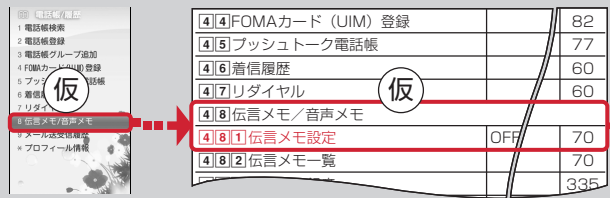

Searching from thumb indices

Functions can be searched by using indices in the order of the front cover, chapter top page and function description page. The chapter top page also gives the list of detailed contents.

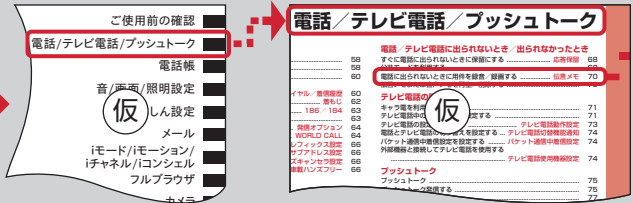

Function name
This name is listed in Index.

Outline and supplementary description of the function

Typical operating procedure

伝言メモ
電話に出られないときに用件を録音／録画する

伝言メモを起動しておくこと、電話に出られないときに応答ガイダンスが流れ、相手の用件が録音／録画されます。

- 音声電話とテレビ電話を合わせて最大4件、1件につき約30秒間録音／録画できます。
- 2in1利用時、AナンバーとBナンバーに着信した伝言メモを合わせて最大4件録音／録画できます。表示はモードによって異なります。
- プッシュトークでは利用できません。

◆ 伝言メモを起動する

- 通常スタイルで操作してください。
- 1** **[]** (1秒以上) ▶ **[1]** ▶ **[1]** または **[2]**
- [ON] にすると、待受画面に **[]** が表示されます。
- 伝言メモの起動中に電話がかかってくると **[]** が表示され、電話がかかってくるまで待受画面に **[]** が表示され、電話が通話中に **[]** が表示され、電話が通話終了後に **[]** が表示され、伝言メモの録音／録画が完了します。

70 電話／テレビ電話／プッシュトーク

Supplementary description of the operation

Detailed description and convenient information about the function

2 相手のメッセージが録音／録画される

- 開始時と終了時に相手には確認音（ビーツ）が鳴ります。また、開始時から約25秒後に終了予告音（ピビツ）が鳴ります。

3 録音／録画が終了すると、電話が切れる

◆ クイック伝言メモに対応する〈クイック伝言メモ〉

伝言メモを起動していなくても、着信中に **[]** を1秒以上押すと、その着信に限り伝言メモを1回だけ動作させられます。この操作は、伝言メモを開始に設定する操作ではありません。

仮 お知らせ

応答ガイダンス中、伝言メモ録音／録画中でも **[]** を押すと電話に接続することができます。テレビ電話の場合は **[]** を押しても出られません。このとき、電話を受けるまでの録音／録画内容は記録されません。

- 圏外や電源が切れているときは、伝言メモは動作しません。留守番電話サービスをご利用ください。
- 伝言メモが4件録音／録画されると、待受画面に **[]** が表示され、伝言メモおよびクイック伝言メモは動作しません。不要な伝言メモを削除してください。留守番電話サービスまたは転送でんわサービスを開始している場合は各サービスが動作します。

* The page shown here represents an example. Images may differ from actual page in this manual.

- In this manual, operation by pressing keys is represented by graphic symbols. → P22 "Part names and functions"
- The representations and meanings of operating procedures are as shown below.

Representation example	Meaning
[] (1 sec. or more)	Press [] for 1 second or more.
[] [Settings & NW services] [5] [7] [2] ▶ [1] - [3]	On the stand-by display, [], move the cursor to [Settings & NW services] and press []. Successively, press [5] [7] [2], then press any of [1] - [3].

- In this manual, to select an item by placing the cursor with **[]** **[]** **[]** **[]** (Multi-cursor key) and pressing **[]** (Enter key) is referred to as "select". Regarding an operation to enter characters in the entry field, the final step of pressing **[]** [OK] is omitted.
- This manual uses the default settings to describe operations. If the settings are changed, the displays or operations of FOMA terminal may differ from the ones described in this manual. For the default settings, see Menu List. → P386

Easy Search

Functions which you want to know can be searched for using friendly words.



Convenient functions for calls

Showing/Hiding your phone number	Caller ID notification	48
Putting the call on hold	On hold	51
Changing the volume of the other party's voice	Listen volume	51
Switching from voice call to videophone call	Switching to videophone call	52



When you cannot answer the call

Putting the call on hold when you cannot answer it immediately	Respond and Hold	61
Notifying the caller that you have to refrain from talking	Public mode (Drive mode)	61
.....	Public mode (Power OFF)	62
Recording the other party's voice or image	Answer machine	62



Changing sound, lighting color and vibration

Setting different ring tone etc. for incoming calls from specific parties	Alert by contact	75
Changing ring alert	Ring alert	83
Changing loudness of ring tone	Adjust volume	84
Making vibration when there is an incoming call	Vibrate alert/effect	85

4 Easy Search/Contents/Precautions

Muting keypad sound	Keypad sound	86
Setting silent mode	Silent mode	87
Changing the color of keypad light	Keypad light	92
Changing color such as light	Light alert	98



Changing displays

Meanings of icons on display	Viewing display	26
Switching the menu display	Selecting functions from menu	30
Changing stand-by display	Stand-by display	88
Displaying a calendar on stand-by display	Info/calendar layout	89
Changing font size	Font size	99



Safety and security

Hiding contents of phonebook	Secret attribute	80
Locking FOMA remotely in case of misplacement etc.	Omakase Lock*¹	105
Rejecting calls with no caller IDs	Anonymous caller	118
Rejecting calls from parties not saved in phonebook	Unregistered caller	119
Saving data such as phonebook in case of data loss	Data Security Service*²	119



Making full use of mail

Sending Deco-mail	Deco-mail	127
Sending images and/or melodies	Attachment	132
Automatically sorting mails	Sort method	147



Making full use of camera

Saving shot still images to microSD card	Save to	193
Changing image size	Still image settings/Recording settings	198
Viewing shot still images	Displaying image	286



Making full use of 1Seg

Watching 1Seg	Activate 1Seg	210
Recording 1Seg	1Seg recording	216
Reserving watching/recording 1Seg	Watching/Recording reservation	217
Changing settings of images and sounds	User setting	221

*1 A charged service.

*2 A charged service requiring subscription.

- For procedures to search for other functions, see "How to use this manual". → P1
- Quick Manual introduces you procedures for using convenient functions. → P2



Other convenient functions

Reading QR and/or bar code	Bar code reader	204
Listening to music	MUSIC Player	228
Using GPS function	GPS function	272
Using microSD card	microSD card	298
Sending or receiving data via infrared communication	Infrared communication	310
Using alarm clock	Alarm clock	323
Using calculator	Calculator	336
Using a mobile phone overseas	International Roaming	370
Updating software	Software update	427
Keeping security software updated	Scanning function	431

Contents

■ Before using your FOMA terminal	Inside front cover
■ Viewing/Searching this manual	1
■ Easy Search	4
■ Main functions of F-03A	8
■ Precautions (ALWAYS FOLLOW THESE DIRECTIONS)	10
■ Handling precautions	17
■ Accessories and main options	20

Before Using the Handset 21

Part names and functions Available styles
Viewing display Selecting menu Touch panel
Motion sensor Using UIM (FOMA card)
Attaching/Removing battery pack Charging
battery Battery level Power ON/OFF Select
language Date & time Caller ID notification
User information etc.

Voice/Videophone Calls/ PushTalk..... 49

Making a call Redial/Received calls Chaku-
moji 186/184 Tone signal (DTMF) Call option
WORLD CALL Receiving a call Any key
answer Close settings Respond and Hold
Public mode Recorded messages Using
Chara-den Videophone settings Notify of
switchable mode Making/Receiving a
PushTalk call PushTalk phonebook PushTalk
alert etc.

Phonebook 73

Phonebook new entry Alert by contact Group
settings Search/Edit/Delete phonebook
Secret attribute Quick dial etc.

Sound/Screen/Light Settings 81

Ring alerts & Sounds Adjust volume Vibrate
alert/effect Silent mode Timed theme Stand-
by display Call image Mail image Power
saving mode Select startup menu Display
Machi-chara Kisekae Tool Light alert Clock
display format etc.

Security Settings..... 101

Security code Terminal security code change
PIN code All lock Omakase Lock Self mode
Personal data lock Keypad dial lock Privacy
mode Operation lock Auto keypad lock
Accept/Reject call Data Security Service Reset
Delete all data Initializing remotely Remote
customization etc.

Mail 125

Creating/Sending i-mode mail Deco-mail
Decome-Anime Attachment Saving i-mode
mail Quick mail Receiving i-mode mail Check
new message Operating Inbox/Outbox Mail
settings Messenger/F Area Mail Creating/
Sending SMS etc.

i-mode/i-motion/i-Channel/i- concier 161

Site display Change i-mode password Go to
location Bookmark Screen memo
Downloading from site Uploading to site i-
mode settings Operating certificate i-motion
i-Channel i-Channel ticker i-concier etc.

Full Browser..... 183

Displaying web pages designed for PC Setting
Full Browser etc.

Camera..... 189

Still camera Movie camera Sound recorder
Advanced settings Setting for shooting Bar
code reader etc.

1Seg207

Setting channels 1Seg watching Program guide i-appli Data broadcasting TVlink Multi window Recording Reserving Remote controller with microphone etc.

Music223

Setting program Operating Music&Video Channel Saving music data Playing/Managing music data BGM play Remote controller with microphone etc.

i-appli/i-Widget237

Downloading Starting i-appli i-appli To i-appli stand-by display i-appli call Managing i-appli i-Widget etc.

Osaifu-Keitai/ToruCa261

iC transfer service Starting Osaifu-Keitai compatible i-appli IC card lock Receiving ToruCa etc.

Map/GPS Function271

Position location GPS compatible i-appli Location request Notify location Loc. history Loc. history Map setting Setting GPS etc.

Data Management 285

Displaying/Editing image Playing/Editing movies/i-motion Displaying Machi-chara Displaying Chara-den Playing melody microSD card Managing data Infrared communication/iC transmission Displaying PDF Displaying Word, Excel, PowerPoint files Displaying recorded data of 1Seg etc.

Convenient Functions 319

Multiaccess Multitask Quick search Auto power ON/OFF Countdown timer Alarm clock Scheduler Shortcut icons Custom menu Side key shortcut Fake call Voice memo/Movie memo Call duration/Call cost Calculator Notepad Dictionaries Pedometer Earphone/Microphone with switch Bluetooth® etc.

Character Entry 349

5-touch input method Save phrase Copying/Cutting characters KUTEN code input Save word Password manager DL dictionary 2-touch input Text input method Touch entry etc.

Network Services 359

Voice Mail Service Call Waiting Call Forwarding Service Nuisance Call Blocking Service Caller ID Request Service Dual Network Service English guidance Service numbers Arrival call act Remote control Multi Number 2in1 OFFICEED Additional service etc.

Overseas use 369

Overview of international roaming service (WORLD WING) Services available Preparing and checking for overseas use Making/Receiving a call Network search mode PLMN setting 3G/GSM setting Area service status Roaming guidance Bar calls at roaming Network services etc.

PC Connection 379

Data communication DOCOMO keitai datalink etc.

Appendix/Troubleshooting ... 385

Menu list Combination of Multiaccess/Multitask functions Services available Introduction of options and related devices Error messages Warranty and After-Sales Service Software update Scanning function SAR certification information Intellectual Property Right etc.

Index/Quick Manual 1

Index Quick Manual Quick Manual (Overseas Use)

Main functions of F-03A

i-concier

i-concier is a service to use FOMA terminal conveniently in which a character on the stand-by display (Machi-chara) notifies you of useful information like "Concierge" and you can download schedules/i-schedule from a site. With i-concier, downloaded schedule or ToruCa is automatically updated with the latest information, and address information etc. of stores and companies are automatically added to the phonebook.→P180

i-appli call

i-appli call is a function allows a third party or content providers to prompt predetermined i-appli to be activated and it is used for activating other party's applications to play a versus game etc.→P253

i-Widget

i-Widget is a function that allows you to easily access frequently-used contents (widget applications) such as calculator, clock, a TV program guide and stock price information. You can also check the latest information at a glance by activating i-Widget screen.→P257

1Seg

You can watch "1Seg", a terrestrial digital TV broadcast for mobile devices. You can also shoot still images and record video while watching 1Seg. Dubbing+10 (→P301) is supported for recording video.→P208

International Roaming

While staying overseas, you can use the same FOMA terminal, phone number and mail address as those used in Japan (3G/GSM Areas are supported).→P370

And, Japanese-English/Japanese-Chinese version of "しゃべって翻訳 for F (Speech Translation for F)", an application that interprets your Japanese into English or Chinese and your English or Chinese into Japanese, is preinstalled.→P244

Direct touch (仮) and Touch selector

You can touch the dedicated menu or slide on the screen to operate while using Full Browser or 1Seg that is suitable for the horizontal display (Direct touch). You can use Touch selector on the vertical display with FOMA terminal folded to perform the same operations as using keys with FOMA terminal opened.→P33

Motion sensor

You can stop alarm sound by double-tapping FOMA terminal or enjoy watching light or Flash graphics change by tilting FOMA terminal. While an image is being displayed, the vertical/horizontal position of the display or the display size changes according to the orientation of the terminal. And for Full Browser, the screen can be also scrolled by tilting the terminal.→P38

Super clear-voice 2 and Voice slowing

Super clear-voice 2 (→P52) is a function that detects ambient noise and optimizes the other party's voice by limited vocal range to make the voice be heard clearly. "Voice slowing" adjusts the speed of the other party's voice to improve the voice clarity.

Rainbow key light

You can change the keypad light color to 7 colors.→P92

Machi-chara

You can display a character which moves around on the stand-by display etc. You can also download Machi-chara.→P94, 170, 296

Auto keypad lock and Immobile sensor

In addition to Lock on close that locks each time FOMA terminal is folded, FOMA terminal is equipped with Auto keypad lock that locks key operations when no operation is made for the specified time. When Immobile sensor is set to "ON", Auto keypad lock is activated when no operations for the specified time and no movements of FOMA terminal are detected together. →P113

High-performance camera

FOMA terminal is equipped with a Approx. 520 million pixels camera that has functions such as a face detection to distinguish people's face, local contrast correction and high-sensitive shooting mode. Just touch the screen to focus in flip style. A still image is saved according to the orientation of camera when the image is shot. →P190

Quick search

On the stand-by display or while performing a function, search functions of i-mode, Full Browser, Map, dictionaries, phonebook or mail can be used by pressing the search key. →P321

Shortcut icons

Only by selecting the icon pasted on the stand-by display for function, file or mail being created, you can start the target operation quickly. And, icon on the stand-by display can be changed freely. →P329

Pedometer

FOMA terminal can be used as a pedometer, and walking distance, consumed calories or quantity of burnt fat can be calculated. →P338
Also, Pedometer widget application is installed so that you can easily check the number of steps or consumed calories measured with the pedometer by using i-Widget. →P249

Bluetooth

A wireless connection can be established between the FOMA terminal and a Bluetooth device. You can talk with handsfree or listen to music while keeping the FOMA terminal in a bag etc. →P341

Other functions



- Videophone call →P50
- Chaku-moji →P54
- Kisekai Tool →P94
- Security Settings →P102
- i-mode mail/Deco-mail/Deco-mail pictogram →P126
- Chaku-uta full^{®*1}/Uta-hodai/Music&Video Channel^{*2}/MUSIC Player/Video clip →P224
- i-appli/Mega i-appli/Chokkan Game →P238
- Osaifu-Keitai/ToruCa →P262
- Map/GPS Function →P272
- Network services →P360
- High-speed communication compatibility →P380

*1 "Chaku-uta full" is registered trademark of Sony Music Entertainment (Japan) Inc.







*2 A charged service requiring subscription.

Precautions (ALWAYS FOLLOW THESE DIRECTIONS)

- Before using your FOMA terminal, or when necessary, read the precautions below to ensure safe use and handling. After reading this manual, keep it carefully.
- These precautions are intended to protect you and others around you. Read and follow them carefully to avoid injury, damage to the product or damage to property.
- The signs below differentiate between the levels of danger that can occur if the product is not used within the specified guidelines.

 DANGER	This sign denotes that death or serious injury may directly result from improper use.
 WARNING	This sign denotes that death or serious injury may result from improper use.
 CAUTION	This sign denotes that bodily injury or damage to property may result from improper use.

- The symbols below show specific directions.

 Don't	This symbol denotes that the action is prohibited.
 No disassembly	This symbol denotes that disassembling the phone or its components is not allowed.
 No wet hands	This symbol denotes that using the phone or its components with wet hands is not allowed.
 No liquids	This symbol denotes that using the phone or its components in a bathroom or other highly humid area is not allowed.
 Do	This symbol denotes that an instruction must be obeyed at all times.
 Unplug	This symbol denotes that the equipment should be unplugged.

■ Precautions contain the description below.

Handling FOMA terminal, battery pack, adapter (including battery charger) and UIM (common).....	11
Handling FOMA terminal	12
Handling battery pack.....	14
Handling optional devices (AC Adapter/DC Adapter/Desktop Holder/In-Car Holder)	15
Handling UIM	16
Handling mobile phones near electronic medical equipment	16

◆ Handling FOMA terminal, battery pack, adapter (including battery charger) and UIM (common)

⚠ DANGER



Don't

Do not use, store, or leave the equipment in hot areas such as near flames or in areas under strong direct sunlight such as inside a vehicle.

May cause the equipment to be deformed or malfunction, and battery pack to leak, heat, burst or ignite, and the capability or life to be reduced or shortened. Overheating on parts of the case may cause burns or injuries.



No disassembly

Do not disassemble or remodel the equipment. Do not solder items onto the equipment.

May cause fire, injuries, electric shock, or malfunction. It may also cause the battery pack to leak, heat, burst or ignite.



No liquids

Do not let the equipment get wet.

Contact with water or other liquids can cause heating, electric shock, fire, malfunctions or injuries. Take care of the place for use and treatment of the equipment.



Do

Use the battery pack and adapter (including battery charger) specified by NTT DOCOMO for your FOMA terminal.

Use of equipment not specified by DOCOMO can cause FOMA terminal, battery pack and other parts to leak, heat, burst, catch fire or malfunction.

Battery Pack F10
 Desktop Holder F29
 FOMA AC Adapter 01/02
 FOMA DC Adapter 01/02
 FOMA Dry Battery Adapter 01
 FOMA USB Cable with Charge Function 01/02

FOMA Portable Charging Adapter 01
 FOMA AC Adapter 01 for Global use

* Contact a sales outlet such as DOCOMO Shop for information on other compatible products.

⚠ WARNING



Don't

Do not put the battery pack, FOMA terminal, adapter (including battery charger) or UIM in microwave ovens or other heating appliances or high-pressure containers.

May cause the battery pack to leak, heat, burst or ignite, FOMA terminal, adapter (including battery charger) or UIM to heat, smoke, ignite, or damage circuits.



Don't

Do not throw the equipment or give hard shock to it.

May cause the battery pack to leak, heat, burst or ignite, and the equipment to malfunction or catch fire.



Don't

Keep conductive materials (metal pieces, pencil lead, etc.) from coming in contact with the charging jack or external connection jack. Do not put those materials inside the terminal.

May be subject to electrical short and could cause fire or malfunction.



Do

Turn FOMA terminal OFF before entering a place such as a gas station where flammable gases are generated.

Do not charge the battery. The gas may catch fire.

When using Osaifu-Keitai in a place as a gas station, turn OFF the terminal before using it. (When IC card lock is activated, deactivate it before turning OFF the terminal.)



Do

If the equipment starts giving off a strange smell, overheats, becomes discolored or deformed during use, charging or in storage, immediately perform the following operations.

1. Remove the power plug from the wall outlet or cigarette lighter socket.
2. Turn FOMA terminal OFF.
3. Remove the battery pack from FOMA terminal.

May cause the equipment to heat, burst or ignite or the battery pack to leak if you keep using the equipment.

⚠ CAUTION

Don't

Do not leave the equipment on unstable or sloping surfaces.

May cause malfunction or injuries.



Don't

Do not store the equipment in extremely humid, dusty or hot areas.

May cause malfunction.



Do

Children using the equipment should be instructed in proper operation by an adult. Do not allow them to use the equipment without adult supervision.

May cause injuries.



Do

Store the equipment out of reach of small children.

May be accidentally swallowed or cause injuries.



Do

Be careful especially when using FOMA terminal connected to the adapter (including battery charger) continuously for a long time.

If you execute i-appli, use videophone call or watch 1Seg while charging the battery pack, FOMA terminal, battery pack and adapter (including battery charger) may become hot. Directly touching a hot part for a long time, you may have redness, itching or rash on your skin, or it may result in low-temperature burns depending on your constitution and/or health condition.

◆ Handling FOMA terminal**⚠ WARNING**

Don't

Do not direct the infrared data port toward your eye and transmit signals.

May affect your eyes. Faulty operation could result from directing the infrared data port toward other infrared equipment and transmitting signals.



Don't

Do not turn on the light by getting the lighting part closer to other person's eyes.

May impair eyesight. And may cause accidents like injury etc., by dazzling or astounding other people.



Don't

Do not put FOMA terminal in the place such as the dashboard near the air-bag, where the influence of air-bag explosion is expected.

When the air-bag explodes, FOMA terminal may hit yourself or others and could cause injury, equipment malfunction or damage.



Don't

When you use electronic medical equipment, do not keep the terminal in your chest pocket or inside pocket.

Using your FOMA terminal near medical electronic equipment could cause equipment failure.



Don't

Do not put foreign objects such as liquid like water, metal pieces or burnable things into UIM or microSD card slot.

May cause fire, electric shock or malfunction.



Don't

Do not turn on the light aiming directly at the driver of the car etc.

May disturb driving and cause an accident.



Do

Turn FOMA terminal OFF in areas where use is prohibited, such as in airplanes and hospitals.

May cause electronic equipment or electronic medical equipment to fail or malfunction. If the function which automatically turns the power ON is set, cancel the setting before turning the power OFF.

When using the phone in a medical facility, be sure to observe the regulations of the facility. If you do prohibited act such as using the phone in an airplane, you may be punished according to law.



Do

When you talk by setting handsfree, always keep FOMA terminal away from your ear.

And, when connecting the earphone/microphone to FOMA terminal and play a game or music, adjust the volume moderately.

Too loud volume may cause a hearing loss. And, if you cannot hear the sound around you clearly, it may cause an accident.



Do

If you have weak heart, be careful when setting the Vibrate alert (vibration) or alert volume setting.
Could affect heart function.



Do

If it starts thunder while using the terminal outdoors, turn the power OFF immediately, and move to a safe location.

May be subject to lightning strike and could cause electric shock.



Do

Turn FOMA terminal OFF near high-precision electronic control equipment or electronic equipment using low-power signals.

May cause the equipment to fail or malfunction.

* Examples of electronic equipment to avoid.

Hearing aids, implanted pacemakers or defibrillators, other electronic medical equipment, fire alarms, automatic doors and other automatic control equipment.

Users wearing implanted pacemakers or defibrillators or other electronic medical equipment should check with the manufacturer or sales outlet about the effect of radio frequencies on the equipment.



Do

When the display or camera lens is accidentally broken, be careful of broken glass or exposed internal parts of FOMA terminal.

Surfaces of display and camera lens are made of plastic panels and they are structured for the glass not to scatter, however, if you mistakenly touch broken or exposed parts, you may be injured.

CAUTION



Don't

Do not swing FOMA terminal by its strap.

May cause the terminal damage or failure, or injury to yourself or others.



Don't

When using the motion tracking or motion sensor, check the safety around you, hold FOMA terminal firmly, and do not shake it unnecessarily.

The motion tracking and motion sensor are functions to operate by tilting or shaking FOMA terminal. There is a risk that FOMA terminal hits people or objects around you by shaking it too much, causing a serious accident or damage.



Don't

If you put a metal strap or the like to FOMA terminal, be careful not to let the strap hit people or objects around you when performing motion tracking or using motion sensor.

Accidents such as injury, malfunction or damage may result.



Don't

Do not place magnetic disks or cards with magnetic stripes near FOMA terminal or place inside and fold the terminal.

Data stored on media such as cash cards, credit cards, telephone cards and floppy disks may be erased if the storage medium is placed near the phone.



Don't

Do not bring magnetized objects close to FOMA terminal.

Bringing strong magnetism close may cause a malfunction.



Don't

If the display part is accidentally broken and liquid crystal leaks out, do not put the liquid in your mouth, inhale, or make contact with your skin.

If the liquid gets into your eyes or mouth, rinse it with clean water and see a doctor immediately.

And, if the liquid adheres to skin or clothing, use alcohol etc. to wipe it off, then wash with soap.

May cause loss of sight or skin problems.



Don't

Do not bring the speaker close to your ear when the ring alert is sounding or you are playing a melody with FOMA terminal.

May cause hearing loss.



Do

In rare cases, using the phone in some vehicle models can cause the vehicle's electronic equipment to malfunction or fail.

In this case, do not use the phone because it may hamper safe driving.



Do

Mobile phones can give some users skin problems such as itching, allergic reactions or rashes. If you develop skin problems, stop using the phone immediately, and see a doctor. FOMA terminal contains metal in the parts below.

Place of use	Material	Surface finishing
Charging jack	Copper gold	Plating
Slide module	Stainless	None
Widget key	ABS	Electrolytic plating
Screw	Screw	Lead plating



Do

When opening or closing FOMA terminal, take care not to have your fingers or strap caught by the terminal.

May cause injuries or damages.



Do

When watching 1Seg, take a certain distance from the display in a fully bright place.

May cause your eyesight to be impaired.

◆ Handling battery pack

- Check that the battery type matches the type displayed on the battery pack label.

Display	Battery type
Li-ion 00	Li-ion battery

⚠ DANGER



Don't

Do not connect a wire or other metal objects to the jack. And, do not carry or store FOMA terminal with objects like a metal necklace.

May cause the battery pack to leak, heat, burst or ignite.



Don't

Do not try to force the battery pack onto FOMA terminal if you are having trouble installing it. Always install it after checking that it is correctly oriented.

May cause the battery pack to leak, heat, burst or ignite.



Don't

Do not throw the battery pack into the fire.

May cause the battery pack to leak, heat, burst or ignite.



Don't

Do not nail the battery pack, hit with a hammer or step on it.

May cause the battery pack to leak, heat, burst or ignite.



Do

If the battery pack's fluid contacts eyes, immediately flush the eyes with clean water and see a doctor right away. Do not rub the eyes.

May cause loss of sight.

⚠ WARNING



Don't

If the battery pack seems to have abnormalities such as deformation or scratches due to an external impact or falling, stop using it immediately.

May cause the battery pack to leak, heat, burst or ignite, and the equipment to malfunction or catch fire.



Do

If the battery pack does not have a full charge after being charged for the specified time, stop charging it.

May cause the battery pack to leak, heat, burst or ignite.



Do

If the battery pack leaks or gives off a strange smell, immediately remove it from the vicinity of open flames.

The vapors from leaking battery pack fluid may ignite or explode.



Do

Be careful not to let your pet bite the battery pack.

May cause the battery pack to leak, heat, burst or ignite, and the equipment to malfunction or catch fire.

⚠ CAUTION

Don't

Do not discard old battery packs together with other garbage.

May cause igniting or environmental destruction. Tape the terminals of old battery packs to insulate them, and then bring them into a sales outlet such as DOCOMO Shop. If your local municipality has a battery recycling program, dispose of them as provided for.



Don't

Do not charge a wet battery pack.

May cause heat generation, ignition or rupture of the battery pack.



Do

If the battery pack's fluid contacts skin or clothes, immediately flush the contacted area thoroughly with clean water.

May hurt the skin.

◆ Handling optional devices (AC Adapter/DC Adapter/Desktop Holder/In-Car Holder)**⚠ WARNING**

Don't

Do not use the adapter (including battery charger) cord or power cord if it gets damaged.

May cause electric shock, heat or fire.



Don't

Do not use the AC adapter or desktop holder in a bathroom or other highly humid area.

May cause electric shock.



Don't

Always use the DC adapter with a negative-ground vehicle. Do not plug it into a positive-ground vehicle.

May cause fire.



Don't

When it starts to thunder, do not touch FOMA terminal and adapter (including battery charger).

May be subject to lightning strike and could cause electric shock.



Don't

Do not short the charging jack while it is connected to the outlet or cigarette lighter socket. Do not touch the charging jack with a part of your body such as your hand or finger.

May cause fire, malfunction, electric shock or injuries.



Don't

Place battery charger and desktop holder in a stable location while charging. Do not cover or wrap battery charger and desktop holder with a cloth, blanket, etc.

May cause FOMA terminal to be removed or the optional devices to be heated, resulting in fire or troubles.



Don't

Do not place heavy objects on the adapter (including battery charger) cord or power cord.

May cause electric shock or fire.



No wet hands

Do not touch the adapter (including battery charger) cord or outlet with wet hands.

May cause electric shock.



Do

Only use with the specified power source and voltage.

If incorrect voltage is used, this may cause fire or failure. When using FOMA terminal overseas, use AC Adapter for global use.

AC adapter : AC100V

DC adapter : 12 or 24V DC (specific for negative ground vehicle)

AC adapter for global use : Between 100V and 240V AC (Connect to the AC outlet for internal household use)



Do

If the DC adapter's fuse blows, replace it only with the specified fuse.

Using other fuses may cause fire or equipment failure. For the specified fuse, see the instructions that come with the DC adapter.



Do

Wipe off any dust that accumulates on the power plug.

May cause fire.



Do

When you connect the AC adapter to an outlet, make sure not to touch with metal such as metal straps and firmly connect to the outlet.

May cause electric shock, electrical short or fire.



Do

When you disconnect the adapter (including battery charger) from the outlet or cigarette lighter socket, do not pull the adapter (including battery charger) cord or power cord with excessive force; instead hold the plug to disconnect.

Pulling the cord could damage it, possibly leading to electric shock or fire.



Unplug

Always remove the power plug from the outlet when not using the adapter for an extended period.

May cause electric shock, fire or malfunction.



Unplug

Immediately remove the power plug from the outlet or cigarette lighter socket if water or other fluids get into the adapter.

May cause electric shock, smoke or fire.



Unplug

Always remove the power plug from the cigarette lighter socket when cleaning the equipment.

May cause electric shock.

◆ Handling UIM

⚠ CAUTION



Do

Be careful of the cut surface when removing UIM (ICs).

May hurt hands or fingers.

◆ Handling mobile phones near electronic medical equipment

- These precautions are based on the guidelines produced at the Electromagnetic Compatibility Conference Japan, regarding the protection of electronic medical equipment from radio waves emitted by mobile phone units.

⚠ WARNING



Do

Obey the following rules inside medical facilities.

- Do not bring FOMA terminal into operating rooms (ORs), intensive care units (ICUs) or coronary care units (CCUs).
- Turn FOMA terminal OFF in hospital wards.
- Turn FOMA terminal OFF in hospital lobbies and corridors if electronic medical equipment could be nearby.
- If the medical facility has specified zones where use or possession of mobile devices is prohibited, obey those instructions.
- If the function to automatically turn ON the power is set, cancel the setting before turning the power OFF.



Do

Turn FOMA terminal OFF in crowded trains or other public places where pacemaker or defibrillator wearers could be nearby.

FOMA terminal's signals may affect the operation of implanted pacemakers or defibrillators, and other devices.



Do

Wearers of implanted pacemakers or defibrillators must carry and use FOMA terminal at least 22 cm away from the implanted device.

FOMA terminal's signals may affect the operation of implanted pacemakers or defibrillators, and other devices.



Do

When electronic medical equipment other than implanted pacemakers or defibrillators are in use outside of medical facilities (such as in home care settings), check with the device manufacturer to determine how the device is affected by electrical signals. FOMA terminal's signals may affect the performance of electronic medical equipment.

Handling precautions

◆ General

- **Do not get FOMA terminal etc. wet**
 - FOMA terminal, battery back, adapter (including battery charger) and UIM are not waterproof. Do not use them in extremely humid places such as a bath, and do not expose them to rain. When you carry the terminal close to your body, dampness from sweat may cause internal corrosion and malfunction. Malfunctions deemed to have been caused by water are not covered by the warranty, and repairs may not be possible. Since these conditions are outside the scope of the warranty, a repair, if at all possible, is charged.
- **Clean FOMA terminal with a dry soft cloth (such as a cloth for eyeglasses).**
 - The display of FOMA terminal may have been applied special coating to improve clearness of the color LCD. When cleaning FOMA terminal, rubbing it roughly with a dry cloth can scratch the display. Take care when handling the unit, and clean it with a dry soft cloth (such as a cloth for eyeglasses). Drops of water or dirt left on the display can cause stains or remove the coating.
 - If FOMA terminal is wiped with alcohol, paint thinner, benzine or detergent, the printing may disappear or color may fade.
- **Clean the jack occasionally with a dry cotton swab.**
 - If the jack is dirty, the contact may become poor and the power may shut OFF. A dirty jack can result in poor charging, so clean it with a dry cloth or cotton swab.
- **Do not place FOMA terminal near an air-conditioner outlet.**
 - The rapid change in temperature may cause condensation, causing internal corrosion and malfunction.
- **When using, be careful not to subject excessive force to FOMA terminal or the battery.**
 - If FOMA terminal is crammed into a brimming bag or placed in a pocket and sat on, display, internal PCBs or battery pack may be damaged or malfunction. And, if external devices are plugged into the external connection jack (earphone/microphone jack), the breakage of the connector or malfunction may result.
- **Carefully read the separate instructions that come with FOMA terminal, adapter (including battery charger) and desktop holder.**
- **Do not rub or scrape the display with a metal piece etc.**
 - It may scratch the display, causing malfunction or damage.

- **Do not press the surface of the touch panel strongly or operate it with sharp objects such as a nail, a ballpoint pen and a pin.**
 - It may damage the touch panel.

◆ FOMA terminal

- **Avoid extreme temperature.**
 - Use FOMA terminal where the ambient temperature ranges between 5 and 35°C and humidity ranges between 45 and 85%.
- **FOMA terminal may affect land-line phones, TVs or radios in use nearby, so use it as far as possible from these appliances.**
- **Maintain a separate record of the data you saved in your FOMA terminal.**
 - If the data is deleted, DOCOMO assumes no responsibility for the loss of any data.
- **Do not plug external devices into the external connection jack (earphone/microphone jack) at a slant, or do not pull it forcibly while it is plugged.**
 - May cause malfunction or damage.
- **Do not fold FOMA terminal with the strap held inside.**
 - May cause malfunction or damage.
- **It is normal for FOMA terminal to become warm during use or charging. Continue to use it.**
- **Do not leave FOMA terminal with the camera in areas under strong direct sunlight.**
 - May cause discoloring or burn-in of materials.
- **FOMA terminal should normally be used with the external connection jack cap and the memory card slot cover closed.**
 - Dust and/or water brought into FOMA terminal cause troubles.
- **Do not use FOMA terminal with the back cover removed.**
 - It may cause the battery to come off, or may cause a malfunction or damage.
- **Do not attach labels or stickers on the exposed rear side of the FOMA terminal display.**
 - Labels or stickers may get stuck when FOMA terminal is opened/closed causing malfunction or damage.
- **While microSD card is being accessed, do not take the card out and do not turn off FOMA terminal.**
 - It may cause data loss or malfunction.

◆ Battery pack

- The battery pack is a consumable part.
 - Replace the battery pack if FOMA terminal has extremely short operation time on a full charge, though it may vary by operating conditions. Purchase a new battery pack of the specified type.
- Charge the battery in an area within the proper ambient temperature range (5-35 °C).
- Always charge before using it for the first time or after extended disuse.
- The operation time provided by the battery pack varies by the operating environment and battery pack's deterioration.
- The battery pack may swell out as it comes to near the end of its lifetime depending on the usage conditions, but it is not a problem.
- Do not preserve or leave the battery pack as it is empty.
 - It may cause the battery pack performance to be degraded or its lifetime to be shortened.

◆ Adapter (including battery charger)

- Charge the battery in an area within the proper ambient temperature range (5-35 °C).
- Do not charge the battery in the areas below.
 - In areas of excessive humidity, dust or vibrations
 - Near land-line phones or TVs/radios
- It is normal for the adapter (including battery charger) to become warm while charging. Continue to use it.
- When using the DC adapter for charging, keep the vehicle engine running.
 - The vehicle's battery could become flat.
- When using an outlet with a mechanism preventing unplugging, follow the handling instructions for that outlet.
- Do not give strong shock. Do not deform the charging jack.
 - May cause malfunction.

◆ UIM

- Do not use excessive force to install/remove UIM.
- It is normal for UIM to become warm during use. Continue to use it.
- Note that DOCOMO assumes no responsibility for malfunctions occurring as the result of inserting and using a UIM with another IC card reader/writer.
- Always keep UIM ICs clean.
- Clean UIM with a soft, dry cloth (such as a cloth for eyeglasses).
- Maintain a separate record of the data you saved in UIM.
 - If the data is deleted, DOCOMO assumes no responsibility for the loss of any data.
- To preserve the environment, bring the old UIM to a sales outlet such as DOCOMO Shop.
- Avoid extreme temperature.
- Take care not to scratch, touch accidentally or short IC.
 - May cause data loss or malfunction.
- Do not drop UIM or subject it to shocks.
 - May cause malfunction.
- Do not bend UIM or place heavy objects on it.
 - May cause malfunction.
- Do not install UIM into FOMA terminal with a label or sticker put on UIM.
 - May cause malfunction.

◆ Bluetooth devices

- This FOMA terminal is equipped with the security features, that are compliant with Bluetooth standards for communication via Bluetooth. However, depending on the settings, there may not be enough security. Be aware of security risks when using Bluetooth.
- DOCOMO assumes no responsibility for any information which may be leaked during communication via Bluetooth.
- With this FOMA handset, you can use a Bluetooth headset, handsfree, audio, dial-up connection and object push device. An audio/video remote control may be available with an audio device (for Bluetooth compatible devices).
- Frequency bands
Frequency bands used by FOMA terminal Bluetooth function are as below.

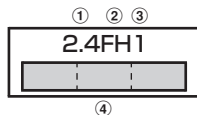

- ① 2.4 : Radio equipment that uses the 2400 MHz band.
- ② FH : The modulation is the FH-SS method.
- ③ 1 : The expected interference distance is 10 m or shorter.
- ④  : All bandwidths between 2400 MHz and 2483.5 MHz are used, and the bandwidth used by mobile object identification devices cannot be avoided.

Cautions on using Bluetooth devices

In the bandwidth used by this handset, in addition to home electric appliances such as a microwave oven and industrial/scientific/medical devices, in-plant radio stations used to identify mobile objects used in production lines of a factory that require a license, specified low power radio stations, or amateur radio stations that do not require a license (hereafter "other radio stations") can be in operation.

1. Before using this terminal, check whether other radio stations are in operation in your neighborhood.
2. If radio wave interference occurs between the terminal and "other radio stations", use the terminal in a different location or "Turn the power OFF" to avoid the radio wave interference.
3. For more detailed information, contact "General Inquiries" using the phone number on the back of this manual.

◆ FeliCa reader/writer

- FeliCa reader/writer function of FOMA terminal uses weak waves requiring no licenses for radio stations.
- It uses 13.56 MHz frequency band. When using other reader/writers in your surroundings, keep FOMA terminal away sufficiently from them. Before using the FeliCa reader/writer, confirm that there are no radio stations using the same frequency band nearby.

◆ CAUTION

- Do not use a remodeled FOMA terminal. Using a remodeled terminal violates the Radio Law.
FOMA terminal is certified according to technical standard conformance of specified wireless equipment based on the Radio Law, and as a proof of it, the "Technical Compliance Mark" is depicted on the engraved sticker of FOMA terminal.
If you remodel FOMA terminal by removing its screws, your certification of technical standard conformance becomes invalid.
- Do not use FOMA terminal with its certification of technical standard conformance invalid as it violates the Radio Law.
- Be careful when you use FOMA terminal while driving a car etc. Using a mobile phone while driving is subject to penal regulations.
If you inevitably receive a call, tell the caller that you will "call back" by handsfree, then park in a safe place and call back.
- Use the Bluetooth function only in Japan.
The Bluetooth function of the FOMA terminal is compliant with wireless standards and is authorized for use only in Japan.
If you use this function overseas, you may be punished.
- Use FeliCa reader/writer function only in Japan.
FeliCa reader/writer function of FOMA terminal conforms to Japanese radio standards.
If you use this function overseas, you may be punished.

Accessories and main options

<Basic package>

F-03A
(including Back Cover F35 and the written warranty)

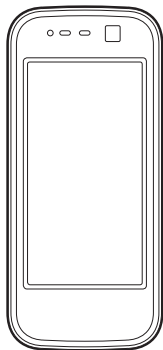

Battery Pack F10

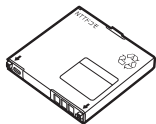

Instruction manual

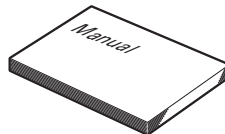

* Quick Manual is appended
on PXXX.

CD-ROM for F-03A

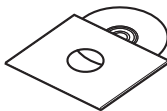

* The PDF version of "Manual for PC Connection" and
"Kuten Code List" are contained in the CD-ROM.

<Optional accessories>

FOMA AC Adapter 01/02
(including written warranty and
operation manual)

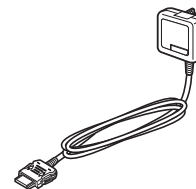

Desktop Holder F29
(including operation manual)

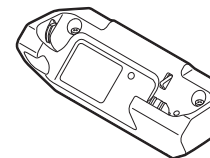

Other optional accessories→PXXX

Before Using the Handset

Part names and functions	22
Available FOMA terminal usage styles	25
Viewing display	26
Selecting functions from menu	30
Selecting functions using touch operation	33
Using motion sensor	38
Using UIM (FOMA card)	39
Attaching/Removing battery pack	41
Charging	42
Checking battery level	45
Turning power ON/OFF	46
Changing screen display to English	47
Setting date and time	47
Notifying the other party of your phone number	48
Checking your own phone number	48

Part names and functions

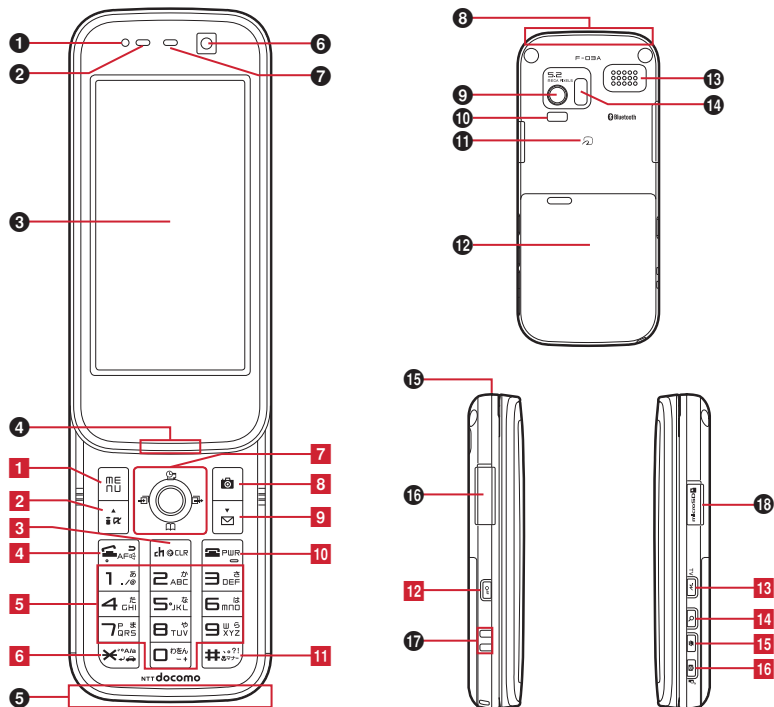

<Using Earphone>

Connect an optional external connection jack compatible earphone.

When using an earphone that is non-compliant to external connection jack, connect an optional plug adapter to use it.

Example of connecting Flat-plug Earphone/Microphone with Switch (optional)

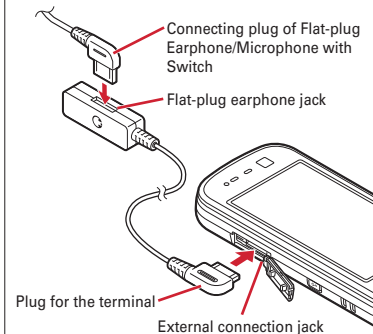

<Functions of parts>

① Light sensor

Sense the ambient luminance (automatic adjustment of the brightness of the display).

* Blocking the light sensor may disable correct adjustment of the brightness.

2 Light

Turn on or blink when receiving a call, mail/i-concier information, calling, obtaining ToruCa, accessing IC card, GPS positioning (Position location, Notify location and Location request), shooting an image, recording a movie, operating Music&Video Channel player or MUSIC Player, sounding tone of Alarm clock, Schedule reminder or Countdown timer, and transmitting IC, or operate according to the settings of Indicator light or Light alert.

3 Display (touch panel) → P26, 33**4 Microphone**

Send your voice from here.

* Do not cover the microphone during a call or sound recording.

5 1Seg antenna → P209

* The terminal has a built-in 1Seg antenna. For better signal reception, do not cover the antenna with your hand.

* When watching 1Seg with FOMA terminal held sideways, it is recommended that the side opposite of the antenna is held as shown below.

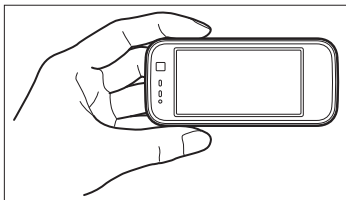
**6 In camera**

Shoot your own image, or send your image via videophone.

7 Earpiece

Hear other party's voice from here.

8 FOMA Built-in antenna

* The terminal has a built-in FOMA antenna. For better voice quality, do not cover the antenna with your hand.

9 Out camera

Shoot still images or movies, send images over a videophone call.

10 Light/Shooting indication light → P65, 199, 331

Camera light for videophone calls, still image shooting, movie recording, simple light, or it turns on or blinks for still image shooting or movie recording.

11 Mark → P262, 311

Installation of IC card

* You can use Osaifu-Keitai by placing  mark over IC card reader or send/receive data by iC transmission. The IC card cannot be detached.

12 Back cover**13 Speaker**

Hear ring alert or voice of the caller using the speakerphone etc. from here.

14 Infrared data port → P310, 314

Infrared communication, Infrared remote control.



15 Strap opening**16 External connection jack**

An integrated connection jack for charging or connecting earphone etc.

* Available to connect an optional AC adapter, DC adapter, FOMA USB Cable with Charge Function, Earphone Plug Adapter for External connector terminal etc.

17 Charging jack**18 microSD card slot → P299****<Functions of keys>**

The functions available by pressing keys are as below.

 : Press  : Press for 1 second or more

1  MENU key

 Display menus, perform the operation shown at the upper left of the guide area.

2  i-mode/i-appli/▲ (scroll)/Character

 Display i-mode Menu.

 Scroll upward the mail screen or site/website display by pages.

 Perform the operation shown in the lower-left corner of the guide area, switch character entry modes.

 Display i-appli folder list.

3  ch/α/Clear key

 Display i-Channel list, switch i-appli stand-by display and i-appli activation.

 Delete characters or return to previous screen.

 Start/Cancel Self mode.

4  Start a voice call/📞/Speakerphone/AF key

 Make/Receive a voice call, return to the previous character while entering characters.

 Switching the speakerphone function, start/cancel auto-focus.

 Make a voice call using the speakerphone function.

 Restore the character string to its previous state.

5 Keypads

 - 

 Enter phone numbers (1-9) or characters, select menu/items.

 Perform the function registered in Custom menu.









 Enter phone number (0) or characters, select menu/items.

 Use Auto switch of Int'l call assist when making international calls.

6  * /A/a/Line feed/Public mode (Drive mode) key

- Enter " * ", " " ", " ° ", etc., switch upper/lower case.
- Line feed while entering characters, select menu/items.
- Switch display/hide of guide area when shooting a still image.
- Switch horizontal and vertical displays while playing movie/i-motion.
- Start/Cancel Public mode (Drive mode).

7 **Multi-cursor key**

- Enter key
 - Perform the operation, activate Focus mode.
 - Start i-appli registered for one-key shortcut.
 -  Schedule/ ↑ key
 - Display Scheduler.
 - Adjust volume, move the cursor upward.
 - Display alarm list
 -  Phonebook/ ↓ key
 - Display phonebook.
 - Adjust volume, move the cursor downward.
 - Add to the phonebook.
 -  Received calls/← (previous) key
 - Display Received calls, switch displays, move the cursor leftward.
 - Start/Cancel privacy mode when "Activate/Deactivate" of Activation option is set to "Hold L-cursor key".
 -  Redial/ →(next) key
 - Display Redial, switch displays, move the cursor rightward.
 - Start/Cancel IC card lock.
- * May be described as   .

8  **Camera key**

- Start still image shooting, perform the operation shown at the upper right of the guide area.
- Start movie recording.

9  **Mail/▼ (scroll) key**

- Display mail menu, perform the operation shown at the lower right of the guide area.
- Scroll downward the mail screen or site/website display by pages.
- Press 2 times : Check new message
- Display mail creation screen

10  **Power/End key**

- Terminate on-hold, calling/operating function, display/hide calendar layout.
- Press for 2 seconds or more : Turn power ON/OFF.

11  **#/Macro shooting/Silent mode key**

- Enter " # ", " " ", " ° ", " ? ", " ! ", " " ", " . ", select menu/items.
- Turn Macro mode on or off while using the camera.
- Start/Cancel Silent mode.

12  **Operation lock key**

- Switch views of the lower guide area when Touch selector is active.
- Activate the Touch panel lock when displaying the standby display with FOMA terminal closed. →P113
- Start/Cancel Operation lock, or cancel Auto keypad lock.
- Cancel/Restart Touch lock during a call or a PushTalk call with FOMA terminal closed. →P115

13  **i-Widget/TV key**

- Start i-Widget
- Watch 1Seg or switch Multi windows.

14  **Search key**

- Enter the target word, place or name and search. →P321

* The setting of Search key shortcut is the operation in the default state.

15  **Multitask key**

- Perform another function while talking or operating (Multiaccess/Multitask).
- Start/Cancel Silent mode with FOMA terminal closed*.

16  **PushTalk/Camera key**

- Start/End/Save shooting when a camera is active, or save a still image during 1Seg watching, when FOMA terminal is closed.
- Stop ring alert, alarm sound or vibrator.
- Activate the quick answer machine while receiving a call, activate/stop voice memo or movie memo during a call.
- Start/Stop video recording during 1Seg watching when FOMA terminal is closed.