



# F-10B

INSTRUCTION MANUAL '10.X

# DOCOMO W-CDMA, GSM/GPRS System

Thank you for purchasing "F-10B" mobile terminal.

Before using F-10B, read this manual to ensure safe use and handling.

## Instruction manuals for F-10B

The operations of F-10B are described in this manual, "使いかたガイド (Guide)" (installed in FOMA terminal) and "Instruction manual (detailed version)" (PDF file).

### Instruction manual (this manual)

This manual provides information about screens and operations of basic functions.

\*  is index term for "使いかたガイド (Guide)".

### "使いかたガイド (Guide)" (installed in FOMA terminal)

This guide provides overviews and operations of frequently-used functions. (In Japanese only)

In F-10B Stand-by display, **[MENU]** ▶ **[6]** LifeKit ▶ **[\*]** Guide ▶ Select a search method

### "Instruction manual (detailed version)" (PDF file)

This manual provides detailed information and operations of all the functions. (In Japanese only)





<From a PC> This manual can be downloaded from NTT DOCOMO website.

<http://www.nttdocomo.co.jp/support/trouble/manual/download/index.html>

\* The URL and contents are subject to change without prior notice.

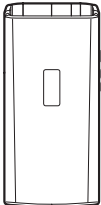
- In this "F-10B INSTRUCTION MANUAL", "F-10B" mobile terminal is usually referred to as "FOMA terminal".
- In this manual, screen images with Kisekai Tool and Color scheme set to "White" are provided.
- The images or illustration used in this manual are examples. They may differ from the actual displays.
- In this manual, "authenticate" indicates the operating procedure for entering the terminal security code in 4-8 digits (⇒P42).

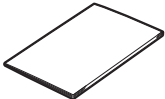
## Basic package

<b>F-10B</b> (including Back Cover F52 and warranty)		<b>Battery Pack F17</b> 	<b>Desktop Holder F30</b> 	<b>To F-10B user</b> 	<b>CD-ROM for F-10B</b> 
			 Desktop Holder F30 is made of recycled ABS from used products.		
					Compatible options→P88

- Unauthorized copying of parts of or this entire manual is prohibited.
- The contents in this manual, URL and contents are subject to change without prior notice.

# Contents

## Introduction

FOMA terminal .....	2
What you can do with F-10B .....	3
Part names and functions .....	4
Precautions (ALWAYS FOLLOW THESE DIRECTIONS) .....	6
Handling precautions .....	13
Waterproofness .....	15

## Basic Operation



Before Using .....	21
Screen Explanation .....	24
Character Entry .....	29
Sound/Screen Setting .....	32
Lock/Security .....	42

## Connect



Call Telephone .....	44
Mail .....	52
Phonebook .....	57

## Search



i-mode/Full Browser .....	59
i-Channel .....	62

## Enjoy



i-appli .....	69
i-motion/Movie .....	70

## More Convenient



i-concier .....	72
Convenient tools .....	73
Data Management .....	78

## Others

Support .....	82
Appendix .....	89
Index .....	102

## Introduction

## Basic Operation

## Connect

## Search

## Enjoy

## More Convenient

## Others

# FOMA terminal

- Because your FOMA terminal uses wireless transmission, it may not function in locations where it is difficult for radio waves to penetrate, such as tunnels, underground passages and some buildings, in areas where radio waves are weak, or out of service area. Even when you are high up in a tall building or condominium and nothing blocks your view outside, your FOMA terminal may not be able to receive or transmit signals. Also, communication may be interrupted even when the signal meter on your FOMA terminal indicates there are strong radio waves and you are not moving (traveling).
- Use your FOMA terminal in a way that does not disturb others in public spaces, crowded locations or quiet places.
- Because your FOMA terminal uses radio waves to communicate, it is possible that a third party may attempt to tap your calls. However, the W-CDMA system automatically applies a confidential communication function to all calls, so even if a third party could somehow tap a call, they only hear noise.
- Your FOMA terminal encodes voice communication as digital data. When you are operating your FOMA terminal while moving to a location subject to weaker radio wave conditions, the transmitted digital data may not be correctly decoded and as a result the decoded voice may differ somewhat from the actual voice.
- Maintain a separate record of the data (Phonebook, Schedule, Notepad, Recorded messages, Voice memos, Moving picture memos, etc.) you registered in your FOMA terminal. Note that DOCOMO assumes no responsibility for any loss of saved contents of data resulting from malfunction, repair, changing of the model or other handling of FOMA terminal.
- You are recommended to save important data to microSD card. Using DOCOMO keitai datalink, you can transfer and save phonebook, mail, schedule and other data to a PC.
- The user hereby agrees that the user shall be solely responsible for the result of the use of SSL/TLS.  
Neither DOCOMO nor the certifier as listed herein makes any representation and warranty as for the security in the use of SSL/TLS. If the data should be erased, DOCOMO assumes no responsibility for the loss of any data.  
Certifier : VeriSign Japan K.K., Cybertrust Japan Co., Ltd., GlobalSign K.K., RSA Security Japan Ltd., SECOM Trust Systems Co., Ltd., Comodo CA Ltd., Entrust, Inc.
- This FOMA terminal supports FOMA Plus-Area and FOMA HIGH-SPEED Area.
- FOMA terminal can be used only via the FOMA network provided by DOCOMO and DOCOMO's roaming area.

# What you can do with F-10B

## 使いかたガイド (Guide)

27

Guide is useful for checking an operating procedure of the function you want to use on FOMA terminal. Without Instruction manual at hand, you can check immediately. (In Japanese only)



## i-concier

72

i-concier is a service to use FOMA terminal conveniently in which a character on the stand-by display (Machi-chara) notifies you of useful information and schedules (i-schedule) can be downloaded automatically from a site. (In Japanese only)



## International Roaming (WORLD WING)

50

While staying overseas, you can use the same FOMA terminal, phone number and mail address as those used in Japan (3G Areas are supported).



## Waterproofness/Dustproofness

15

FOMA terminal is provided with waterproofness IPX5 and IPX7, and dustproofness of IP5X by firmly closing the external connection jack cap, installing the back cover and locking the cover.

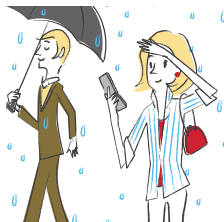

# Part names and functions

Part names of F-10B and major functions assigned to each part are as follows.

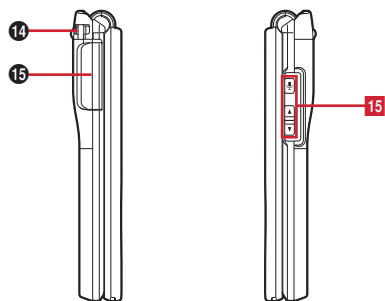
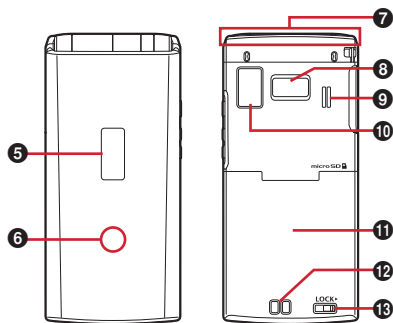
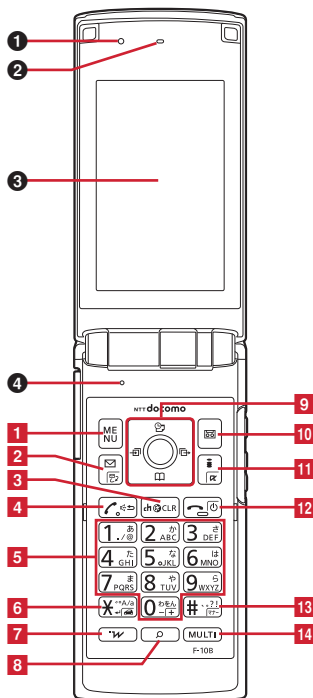

- 1 Light sensor**  
Do not cover the sensor with your hand or a sticker.
- 2 Earpiece**
- 3 Display**⇒P24
- 4 Microphone**  
Do not cover the microphone during a call or sound recording.
- 5 Sub-display** ⇒P25
- 6 Light**  
The light turns on or blinks when the battery charges, etc.
- 7 FOMA antenna (built-in)**  
Do not cover it with your hand.
- 8 Fingerprint sensor**⇒PXX  
Authorize/Register fingerprint
- 9 Speaker**  
Hear ring alert or voice of the caller using the handsfree function.
- 10 Infrared data port**  
Use this port for infrared communication or infrared remote control function.
- 11 Back cover**  
\* To access the UIM slot and microSD card slot, remove the back cover, open the inner lid and remove the battery pack.
- 12 Charging jack**

**13 Back cover lever**

- \* Firmly install the back cover and lock it with the lever before using to avoid water seepage.

**14 Strap opening****15 External connection jack**

Available to connect an optional AC adapter, DC adapter, FOMA USB Cable with Charge Function, Earphone Plug Adapter for External connector terminal etc.

**1 MENU MENU key**

Display a menu.

**2 Mail key/Character key**

Display the mail menu and switch text input mode.

**3 CLR ch/Clear key**

Display i-Channel or return to the previous screen.

**4 Start a voice call key****5 O - [9] Keypads**

Enter phone number or characters, or select an item.

**6 \*/Public mode (Drive mode) key**

Enter "\*" or voiced/semi-voiced sound, or start/cancel Public mode (Drive mode).

**7 i-Widget key**

Start/Exit i-Widget.

**8 Search key**

Start quick search.

**9 Multi-cursor key**

Move the cursor, or operate a menu.

 : Perform an operation.

 : Display Scheduler, or adjust the volume.

 : Display Phonebook, or adjust the volume.

 : Display Received calls.

 : Display Redial.

- \* Operation in eight directions is available depending on the functions.

**10 Call/Voice memo key**

Display call/voice memo, activate/deactivate call memo during a call.

**11 i-mode/i-appli key**

Display i-mode menu or i-appli folder.

**12 Power/End key**

Turn on/off FOMA terminal, or exit a function.

**13 #/Silent mode key**

Enter "#" or punctuation, or start/cancel Silent mode.

**14 MULTI Multitask key**

Start/perform a different function.

**15 Side keys**

 : Turn on the sub-display light, or switch the views.

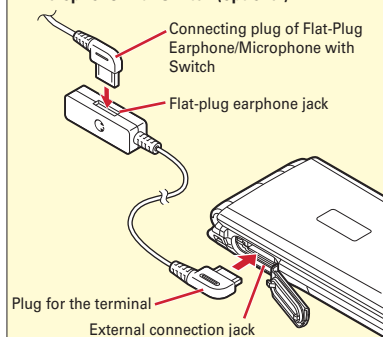

 : Stop the ring tone, alarm sound, vibration, or adjust the volume, or scroll View mail display screen.

 : Adjust the volume, turn on the light on the sub-display or switch the views, or scroll View mail display screen.



**Example of connecting Flat-Plug Earphone/Microphone with Switch (optional)**





# Precautions (ALWAYS FOLLOW THESE DIRECTIONS)

- Before using the FOMA terminal, or when necessary, read the precautions below to ensure safe use and handling. After reading this manual, keep it carefully.
- These precautions are intended to protect you and others around you. Read and follow them carefully to avoid injury, damage to the product or damage to property.
- The signs below differentiate between the levels of danger that can occur if the product is not used within the specified guidelines.

 <b>DANGER</b>	This sign denotes that death or serious injury may directly result from improper use.
 <b>WARNING</b>	This sign denotes that death or serious injury may result from improper use.
 <b>CAUTION</b>	This sign denotes that bodily injury or damage to property may result from improper use.

- The symbols below show specific directions.

 Don't	This symbol denotes that the action is prohibited.
 No disassembly	This symbol denotes that disassembling the phone or its components is not allowed.

 No wet hands	This symbol denotes that using the phone or its components with wet hands is not allowed.
 No liquids	This symbol denotes that using the phone or its components in a bathroom or other highly humid area is not allowed.
 Do	This symbol denotes that an instruction must be obeyed at all times.
 Unplug	This symbol denotes that the equipment should be unplugged.

**■ Precautions contain the description below.**

Handling FOMA terminal, battery pack, adapter, desktop holder and UIM (common).....	7
Handling FOMA terminal .....	8
Handling battery pack .....	9
Handling adapter and desktop holder .....	10
Handling UIM .....	11
Handling mobile phones near electronic medical equipment.....	11



## Handling FOMA terminal, battery pack, adapter, desktop holder and UIM (common)

### DANGER



Don't

**Do not use, store, or leave the equipment in hot areas such as near flames or in areas under strong direct sunlight such as inside a vehicle.**  
May cause fire, burns or injuries.



Don't

**Do not put the terminal into heating cooking device such as microwave oven or high-pressure container.**  
May cause fire, burns, injuries, electric shock.



No disassembly

**Do not disassemble or remodel the equipment.**  
May cause fire, burns, injuries, electric shock.



No liquids

**Do not let the terminal get wet with water, drinking water, urine of pet animals, etc.**  
May cause fire, burns, injuries, electric shock.  
For waterproofness, see⇒P15



Do

**Use the battery pack and adapter specified by NTT DOCOMO for your FOMA terminal.**  
Failure to do so may cause fire, burns, injuries, electric shock.

### WARNING



Don't

**Do not throw the equipment or give hard shock to it.**  
May cause fire, burns, injuries, electric shock.



Don't

**Keep conductive materials (metal pieces, pencil lead, etc.) from coming in contact with the charging jack or external connection jack. Do not put those materials inside the terminal.**  
May cause fire, burns, injuries, electric shock.



Don't

**Do not cover or wrap the terminal with a blanket, etc while using or charging.**  
May cause fire or burns.



Do

**Turn FOMA terminal OFF and stop charging before entering a place such as a gas station where flammable gases are generated.**  
The gas may catch fire.  
When using Osaifu-Keitai in a place as a gas station, turn OFF the terminal before using it.  
(When IC card lock is activated, deactivate it before turning OFF the terminal.)



Do

**If the equipment starts giving off a strange smell, overheats, becomes discolored or deformed during use, charging or in storage, immediately perform the following operations.**

- Remove the power plug from the wall outlet or cigarette lighter socket.
- Turn FOMA terminal OFF.
- Remove the battery pack from FOMA terminal.

Failure to do so may cause fire, burns, injuries, electric shock.

### CAUTION



Don't

**Do not leave the equipment on unstable or sloping surfaces.**  
The terminal may fall and cause injuries.



Don't

**Do not store the equipment in extremely humid, dusty or hot areas.**  
May cause fire, burns, electric shock.



Do

**Children using the equipment should be instructed in proper operation by an adult. Do not allow them to use the equipment without adult supervision.**  
May cause injuries.



Do

**Store the equipment out of reach of small children.**  
May be accidentally swallowed or cause injuries.



Do

**Be careful especially when using FOMA terminal connected to the adapter continuously for a long time.**

If you use i-appli, a videophone call or 1Seg watching while charging the battery for a long time, FOMA terminal, battery pack and adapter may be heated.

Directly touching a hot part for a long time, you may have redness, itching or rash on your skin, or it may result in low-temperature burns depending on your constitution and/or health condition.

## Handling FOMA terminal



### WARNING



Don't

**Do not direct the infrared data port toward your eye and transmit signals.**

May cause harmful effect on eyes.



Don't

**Do not direct the infrared data port toward home electric appliances etc. equipped with infrared device when using infrared communication.**

May cause an accident because of malfunction of infrared device.



Don't

**Do not put foreign objects such as liquid like water, metal pieces or burnable things into UIM or microSD card slot.**

May cause fire, burns, injuries, electric shock.



Do

**Turn FOMA terminal OFF in areas where use is prohibited, such as in airplanes and hospitals.**

Failure to do so may cause electronic equipment or electronic medical equipment to fail or malfunction. If the function which automatically turns the power ON is set, cancel the setting before turning the power OFF.

When using the phone in a medical facility, be sure to observe the regulations of the facility. If you do prohibited act such as using the phone in an airplane, you will be punished according to law.



Do

**When you talk by setting handsfree or ring alert is sounding, keep FOMA terminal away from your ear.**

**And, when connecting the earphone/microphone to FOMA terminal and play a game or music, adjust the volume moderately.**

Too loud volume may cause a hearing loss. And, if you cannot hear the sound around you clearly, it may cause an accident.



Do

**If you have weak heart, be careful when setting the Vibrate alert (vibration) or alert volume setting.**

May cause harmful effect on heart.



Do

**When you use electronic medical equipment, check with the equipment manufacturer to determine how the device is affected by radio waves before using.**

May cause harmful effect on electronic medical equipment etc.



Do

**Turn FOMA terminal OFF near high-precision electronic control equipment or electronic equipment using low-power signals.**

Failure to do so may cause the equipment to fail or malfunction.

\* Examples of electronic equipment to avoid.

Hearing aids, implanted pacemakers or defibrillators, other electronic medical equipment, fire alarms, automatic doors and other automatic control equipment.

Users wearing implanted pacemakers or defibrillators or other electronic medical equipment should check with the manufacturer or sales outlet about the effect of radio frequencies on the equipment.



Do

**When the display or camera lens is accidentally broken, be careful of broken glass or exposed internal parts of FOMA terminal.**

Surfaces of display and camera lens are made of plastic panels and they are structured for the glass not to scatter, however, if you mistakenly touch broken or exposed parts, you may be injured.