

FURUNO

OPERATOR'S MANUAL

DSC/WATCH RECEIVER

MODEL DSC-60



FURUNO ELECTRIC CO., LTD.
NISHINOMIYA, JAPAN

DISTRESS Call Procedure

Do the following when a life endangering situation arises on your vessel:

1. Open the DISTRESS button cover and press the [DISTRESS] button more than three seconds to show the following display, then release the [DISTRESS] button.

Distress call in progress!	
NATURE: UNDESIGNATED	
POS: 12°34N 123°45E AT 12:34	
TELEPHONE	2182.0 KHZ
DSC FREQ :	2187.5 KHZ
TIME TO GO :	38S

2. After the distress call is transmitted the following displays appear in order.

Waiting for distress acknowledgement.	
NATURE: UNDESIGNATED	
POS: 12°34N 123°45E AT 12:34	
TELEPHONE	2182.0 KHZ
DSC FREQ :	2187.5 KHZ
TIME TO GO:	3M10S

When distress call is acknowledged
by coast station (within 1 min to 2 min.
45 sec).

Distress acknowledge call received.	
FROM COAST: 001234567	
SHIP IN DIST: 123456789	
NATURE: UNDESIGNATED	
POS: 12°34N 123°45E AT 12:34	
TELEPHONE	2182.0 KHZ
STOP ALARM	

3. The audio alarm sounds; press the [CANCEL] key to silence the alarm
4. Communicate with the coast station via radiotelephone as follows:
 - a) Say MAYDAY three times.
 - b) Say "This is ..." name of your vessel and your call sign three times.
 - c) Give nature of distress and assistance needed.
 - d) Give description of your vessel (type, color, number of persons onboard, etc.) and any other information which may aid in rescue.

For detailed information see page 3-1.



SAFETY INSTRUCTIONS

WARNING



ELECTRICAL SHOCK HAZARD
Do not open the equipment.

Only qualified personnel should work inside the equipment.

Immediately turn off the power at the switchboard if water leaks into the equipment or something is dropped in the equipment.

Continued use of the equipment can cause fire or electrical shock. Contact a FURUNO agent for service.

Do not disassemble or modify the equipment.

Fire, electrical shock or serious injury can result.

Do not place liquid-filled containers on the top of the equipment.

Fire or electrical shock can result if a liquid spills into the equipment.

Immediately turn off the power at the switchboard if the equipment is emitting smoke or fire.

Continued use of the equipment can cause fire or electrical shock. Contact a FURUNO agent for service.

Make sure no rain or water splash leaks into the equipment.

Fire or electrical shock can result if water leaks in the equipment.

WARNING

Keep heater away from equipment.

A heater can melt the equipment's power cord, which can cause fire or electrical shock.

Do not operate the equipment with wet hands.

Electrical shock can result.

CAUTION

Do not use the equipment for other than its intended purpose.

Use of the equipment as a stepping stool, for example, can result in personal injury or equipment damage.

A warning label is attached to the equipment. Do not remove the label. If the label is missing or illegible, contact a FURUNO agent or dealer.

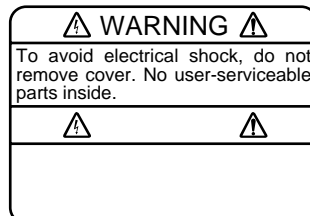

Name: Warning Label (1)
Type: 86-003-1011-0
Code No.: 100-236-230

TABLE OF CONTENTS

FOREWORD.....	vi
SYSTEM CONFIGURATION	viii
1. DSC SYSTEM OVERVIEW	1-1
1.1 What is DSC?.....	1-1
1.2 DSC Call	1-1
1.2.1 Distress alert call and reply.....	1-3
1.2.2 Individual call.....	1-4
1.3 Audio Alarms.....	1-4
1.4 Remote Control and Automatic Acknowledge	1-5
1.4.1 Remote control.....	1-5
1.4.2 Automatic acknowledge	1-5
1.4.3 Both remote control and automatic acknowledge ON	1-5
1.5 Interpreting Call Displays	1-6
1.5.1 Receive calls	1-6
1.5.2 Send calls.....	1-8
1.6 Remote Control of SSB Radiotelephone	1-9
2. OPERATIONAL OVERVIEW	2-1
2.1 Controls, LED Description.....	2-1
2.2 Turning the Power On/Off	2-3
2.3 DSC Standby Screen, Radiotelephone Setting Screen and Their Indications	2-3
2.3.1 DSC standby screen	2-3
2.3.2 Radiotelephone setting screen	2-3
2.4 Panel Backlighting and LCD Contrast.....	2-4
2.5 Loudspeaker, Buzzer On/Off.....	2-5
2.6 Starting, Stopping Scanning DSC Routine Frequencies	2-6
2.7 Automatic Acknowledge On/Off	2-7
2.8 Intercom On/Off.....	2-8
2.9 Selection of On-screen Items.....	2-9
2.10 Manual Entry of Position and Time.....	2-10
2.11 Remote Control of FURUNO SSB Radiotelephone	2-12
3. DISTRESS OPERATIONS	3-1
3.1 Sending Distress Alert.....	3-1
3.1.1 Sending distress alert by DISTRESS button	3-1
3.1.2 Sending distress alert with nature of distress specified	3-3
3.2 Sending Distress Relay to All Ships.....	3-7
3.2.1 Distress alert received on MF band	3-7
3.2.2 Distress alert received on HF band.....	3-13
3.3 Sending Distress Relay on Behalf of a Ship in Distress	3-15
3.3.1 Sending distress relay to coast station	3-15
3.3.2 Sending distress relay to all ships.....	3-18
3.4 Receiving Distress Relay All Ships	3-21

4.	CALLING	4-1
4.1	All Ships Call	4-1
4.1.1	Sending all ships call	4-1
4.1.2	Receiving all ships call.....	4-3
4.2	Individual Call.....	4-4
4.2.1	Sending individual call.....	4-4
	How to set working frequency.....	4-6
	How to set DSC frequency.....	4-8
4.2.2	Receiving individual call.....	4-13
4.3	Group Call	4-18
4.3.1	Sending a group call	4-18
4.3.2	Receiving a group call.....	4-20
4.4	Geographic Area Call.....	4-21
4.4.1	Sending a geographic area call	4-21
4.4.2	Receiving a geographic area call.....	4-24
4.5	Neutral Craft Call.....	4-25
4.5.1	Sending a neutral craft call	4-25
4.5.2	Receiving a neutral craft call.....	4-26
4.6	Medical Transport Call	4-27
4.6.1	Sending a medical transport call.....	4-27
4.6.2	Receiving a medical transport call	4-28
4.7	Polling Call	4-29
4.7.1	Sending a polling call	4-29
4.7.2	Receiving a polling call	4-32
4.8	Position Call	4-34
4.8.1	Position call: requesting other ship's position	4-35
4.8.2	Position call: other ship requests your position.....	4-37
4.9	PSTN Call	4-40
4.9.1	Sending PSTN call, receiving acknowledge back (ACK BQ)	4-40
4.9.2	Sending PSTN call, receiving acknowledge back (QUEUE indication), ring back.....	4-43
4.9.3	Receiving PSTN call, sending acknowledge back (ACK BQ).....	4-47
4.9.4	PSTN call disconnection, receiving charge information (ship disconnects line).....	4-48
4.9.5	PSTN call disconnection, receiving charge information (coast station disconnects line).....	4-50
5.	LOG FILE	5-1
5.1	Log File Description	5-1
5.2	Opening a Log File.....	5-1
5.2.1	Distress log	5-1
5.2.2	Ordinary log.....	5-3
5.2.3	Transmitted log	5-4
6.	PREPARING SEND MESSAGES	6-1
6.1	Preparing Individual Call Messages.....	6-1
6.2	Preparing Group Call Messages.....	6-4
6.3	Preparing Geographic Area Call Messages.....	6-5
6.4	Preparing PSTN Call Messages	6-6
6.5	Sending Prepared Messages.....	6-8

7. SETUP MENU	7-1
7.1 Setup Menu Overview	7-1
7.2 Alarm Menu	7-2
7.3 Auto Ack Menu	7-3
7.4 Erase File Menu	7-5
7.5 Message Menu	7-5
7.6 Position Menu	7-6
7.7 Print Out Menu	7-6
7.7.1 Sample printouts	7-7
7.8 Scan Freq Menu	7-8
7.8.1 Distress frequencies	7-8
7.8.2 Routine frequencies	7-9
7.9 User CH Menu	7-10
7.10 Volume Menu	7-12
7.11 Test Menu	7-13
7.12 System Menu	7-13
8. CHECKING, MAINTENANCE	8-1
8.1 Daily Test	8-1
8.2 Maintenance	8-2
8.2.1 Preventive maintenance	8-2
8.2.2 Cleaning	8-2
8.3 Simple Troubleshooting	8-3
8.4 Error Messages	8-3
8.5 Test Call	8-4
APPENDIX	A-1
Menu Tree	A-1
DSC Frequency Table	A-2
SPECIFICATIONS	SP-1
Declaration of conformity to type	
INDEX	

FOREWORD

Thank you for purchasing this DSC/Watch Receiver. We are confident you will discover why FURUNO has become synonymous with quality and reliability.

Dedicated in the design and manufacture of marine electronics equipment for half a century, FURUNO Electric Company has gained an unrivaled reputation as a world leader in the industry. This is the result of our technical excellence as well as our worldwide distribution and service network.

Please carefully read and follow the safety information and operating and maintenance instructions set forth in this manual before attempting to operate the equipment and conduct any maintenance. Your DSC/Watch Receiver will perform to the utmost of its ability only if it is operated and maintained in accordance with the correct procedures.

Features

Connected to an SSB radiotelephone, the DSC-60 generates and receives digital selective calls for quick and efficient establishment of distress, urgency, safety and routine communications with other ships and coast stations that install any MF/HF DSC facilities. Data is displayed on a large, easy-to-read backlit LCD. Operation is simplified by the use of few keys and easy-to-follow menus.

The main features are

- DSC Terminal, DSC Watch Receiver, DSC General Watch Receiver (option) and MF/HF Radiotelephone Remote Station all contained in a compact and light-weight cabinet.
- Fully meets GMDSS carriage requirements. Large LCD meets requirements of 160-character indication required by IMO MSC.68(68).
- Conforms to the following regulations:
 - IEC-61097-3/8/9
 - IEC-60945 (3rd edition protected from weather, former Class B)
 - IEC-61162-1
 - ETS-300/338
 - ITU-R M.493-9, M.541-8, M.1082-1
- Scan watch feature scans operator-programmed DSC frequencies.
- Remote operation optionally available.
- Automatic position and time input and update with connection of EPFS (Electronic Position-Fixing Equipment).
- Optional printer can automatically print out received messages and test results.
- Log stores 50 each of latest ordinary, distress and transmitted messages, in separate memory blocks.

- Built-in intercom function provides voice communications between the DSC-60 and SSB radiotelephone.
- Optional built-in receiver board for DSC ship's business/routine frequencies.
- One-touch testing facility.

SYSTEM CONFIGURATION

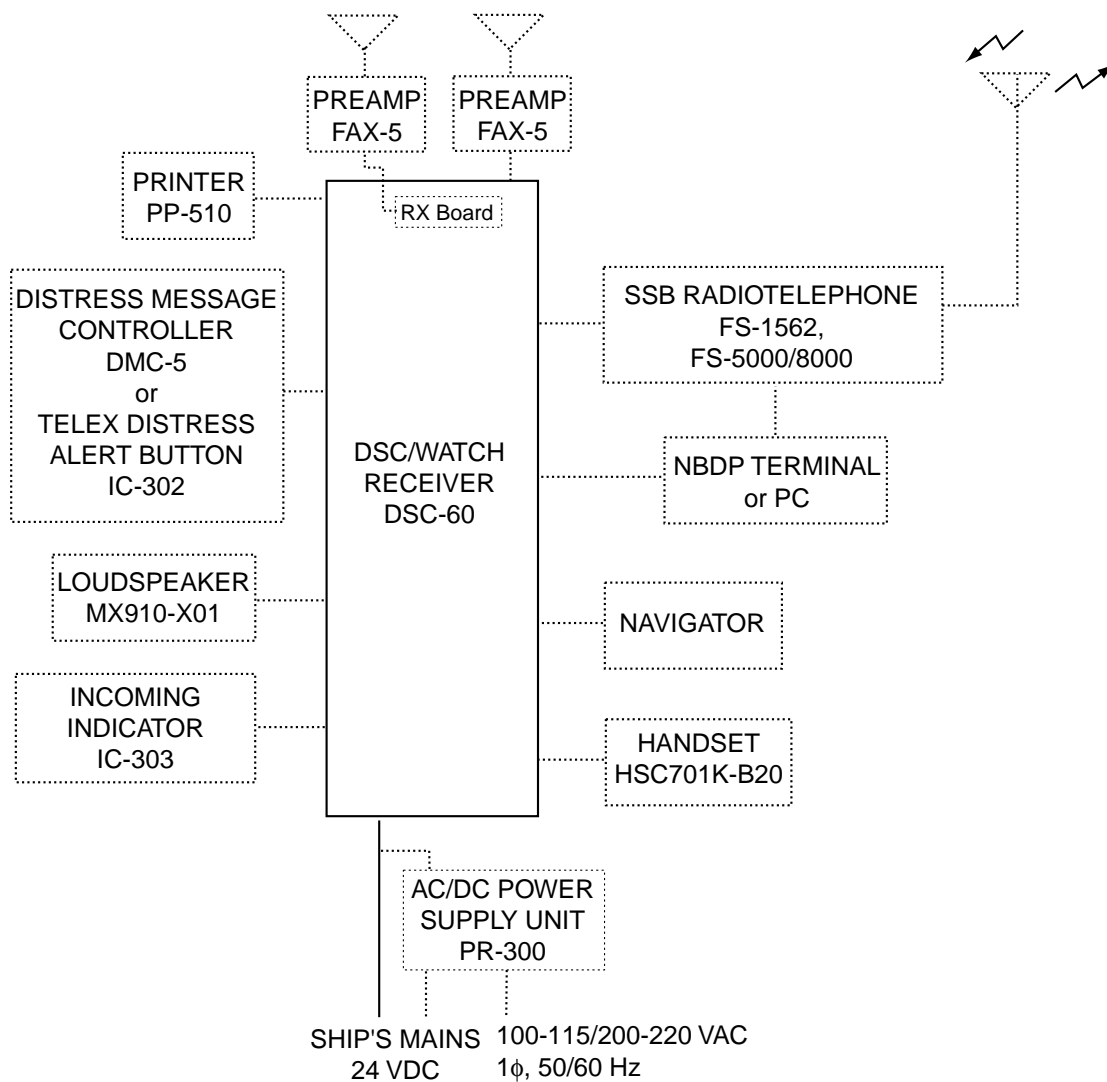

..... : Optional equipment

1. DSC SYSTEM OVERVIEW

1.1 What is DSC?

DSC is an acronym meaning Digital Selective Calling. It is a digital distress and general calling system in the MF, HF and VHF bands used by ships for transmitting distress alerts and general calls and by coast stations for transmitting the associated acknowledgements.

For DSC distress and safety calling in the MF and HF bands the frequencies are (kHz) 2187.5, 4207.5, 6312.0, 8414.5, 12577.0, and 16804.5.

The DSC-60 is a combination MF/HF DSC Terminal and Watch Receiver. Connected to an SSB radiotelephone, the DSC-60 sends and receives calls via the SSB radiotelephone. The built-in remote control permits control of a FURUNO radiotelephone from the DSC-60.

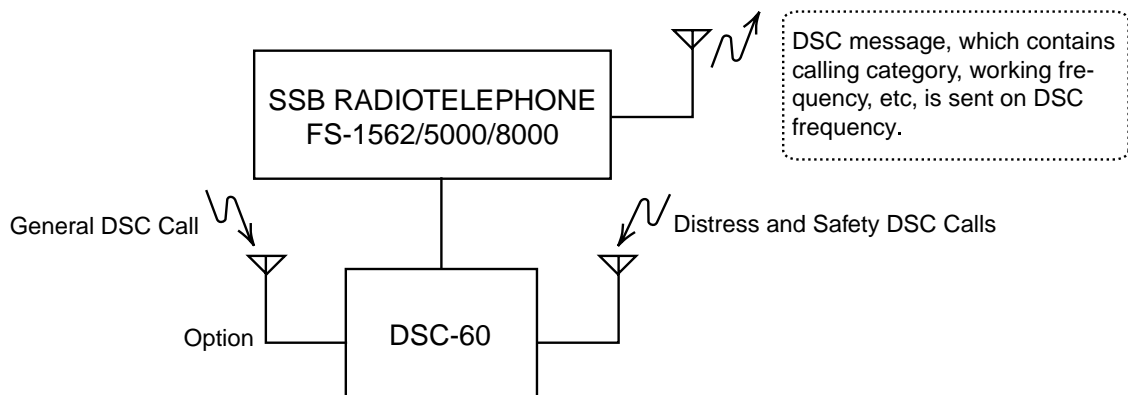

1.2 DSC Call

DSC calls are roughly divided in two categories: distress and safety calls, and routine calls. Below are the types of DSC calls and the pages on which their descriptions and procedures appear.

- All Ships (page 4-1)
- Distress (page 3-1)
- Distress Relay (page 3-7 - 3-20)
- Geographic Area (page 4-21)
- Group (page 4-18)
- Individual (page 4-4)
- Medical Transport (page 4-27)
- Neutral Craft (4-25)
- Polling (page 4-29)
- Position (page 4-34)
- PSTN (page 4-40)
- Test (page 8-4)

Contents of a DSC call

Calling category

Call category	Call
Individual	Individual, PSTN, Test, Position, Polling, Relay Sel (specific coast station)
All Ships	All Ships, Neutral, Medical, Relay All
Group	Group
Geographic Area	Area

Station ID

Own ship ID and sending station ID. Coast station ID begins with 00; Group ID begins with 0.

Priority

Routine: General calling

Business: For passing important alert such as navigation and weather.

Safety: For reporting emergency situation on board a ship.

Urgency: For reporting grave danger on board a ship.

Communication type

Telephone: telephone (J3E) by SSB

NBDP-ARQ: Telex (J2B) mode ARQ via NBDP Terminal

NBDP-FEC: Telex (J2B) mode FEC via NBDP Terminal

Communication frequency

Working frequency used to call. The sending station may have the receiving station (ship or coast station) assign the frequency to use.

Position

Position can be automatically or manually input.

DSC frequency

DSC frequency to use. If the order of communications priority is SAFETY, URGENCY and DISTRESS, select a DSC distress frequency.

End code

The end of a DSC message is denoted by ACK RQ (Acknowledge Request), ACK BQ (Acknowledge Back) or EOS (End of Sequence).

1.2.1 Distress alert call and reply

This type of call is sent by own ship in the event of distress, by pressing the [DISTRESS] button more than three seconds as follows:

1. The LED in the button initially flashes, and lights when the button is pressed more than three seconds. (If the button is pressed less than three seconds the distress alert is not sent. Once the alert is sent it cannot be cancelled.)
2. The DSC-60 sets the DSC distress frequency on the SSB radiotelephone and it transmits the distress alert.
3. After the distress alert is transmitted (about 40 seconds) the DSC-60 waits for the DIST ACK call from a coast station. This usually takes less than 3 minutes and is accompanied with an audio alarm. (If it is not received within 4.5 minutes the distress alert is re-transmitted.)
4. The SSB sets the DSC distress frequency to use to communicate with the coast station. With the optional handset you can communicate through the DSC-60.

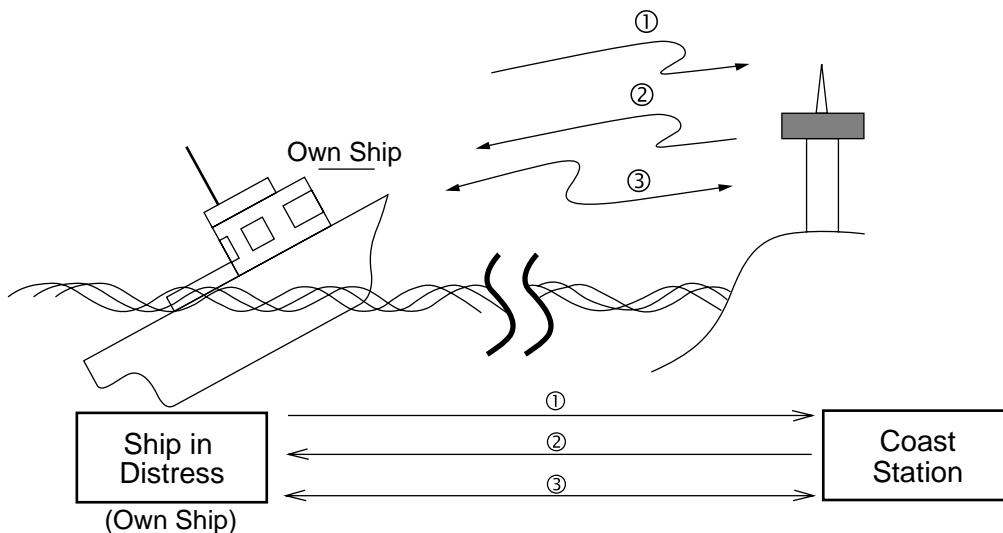

- ① Ship in distress sends Distress Alert.
- ② Coast station sends distress acknowledgement (DIST ACK).
- ③ Voice or telex communications between ship in distress and coast station

1.2.2 Individual call

The individual call is for sending a call to a specific station.

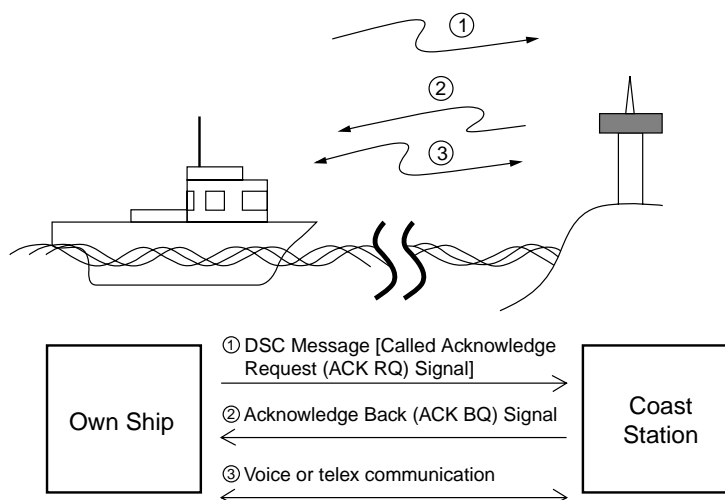

Basic procedure

1. Prepare message and transmit it by pressing the [CALL] key. The DSC-60 then awaits acknowledgement of the call.
2. Receive acknowledge back (ACK BQ) signal from receiving station (coast station or ship station) within about five minutes. The audio alarm sounds at this time; press the [CANCEL] key to silence it.
3. After receiving ACK BQ signal, communicate with coast station; the FURUNO SSB radiotelephone sets the working frequency and class of emission specified by your ship.

1.3 Audio Alarms

When you receive a distress alert or routine call addressed to your ship the audio and visual alarms are released. For the distress or urgent call, the audio alarm sounds until the [CANCEL] key is pressed. For other calls, the audio alarm sounds for one second and then automatically goes off.

The tone of the alarm depends on the call received. By becoming accustomed to the tone you can know which type of call you have received.

Alarm	Frequency (interval)
Safety message received	1300 Hz and 0 Hz (250 ms)
Routine, Ship's Business message received	880 Hz and 440 Hz (500 ms)
While DISTRESS button is pressed for three seconds	2200 Hz and 0 Hz (125 ms)
Distress alert is being sent	2200 Hz, continuous
Own ship position not updated	2200 Hz (50 ms), three beeps every two seconds

1.4 Remote Control and Automatic Acknowledge

1.4.1 Remote control

The DSC-60 and a FURUNO SSB radiotelephone communicate with each other by means of the MIF (FURUNO Radio Interface) data format, a unique handshaking type signal exchange system developed by FURUNO. The DSC-60 can also communicate with other makes of radiotelephones which incorporate data format IEC-61162-1. The remote control feature allows the DSC-60 to automatically set the DSC and working frequencies and class of emission on a FURUNO SSB radiotelephone.

1.4.2 Automatic acknowledge

The automatic acknowledge feature, when turned on, automatically transmits the acknowledge back signal to the sender when an individual, PSTN, position or polling call is received. With the automatic acknowledge feature turned on the remote control is also turned on.

Automatic acknowledge is alternately enabled or disabled with the [5/ACK] key.

1.4.3 Both remote control and automatic acknowledge ON

The illustration and table below outline the sequence of events in an individual call when both remote control and automatic acknowledge are turned on.

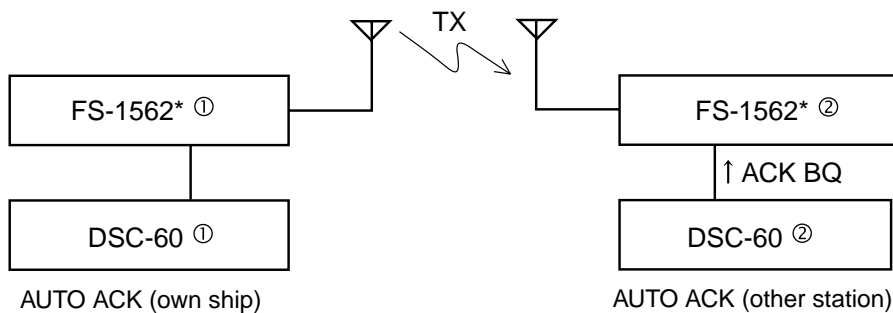

* FURUNO SSB radiotelephone

DSC operation	Radiotelephone frequency ①	Radiotelephone frequency ②
1. DSC-60① [CALL] key pressed.	DSC frequency changed; call sent.	Scans DSC frequencies.
2. DSC-60② receives via radiotelephone.		Sets DSC frequency received.
3. DSC-60② automatically sends acknowledge back (ACK BQ) signal.		DSC frequency set; ACK BQ sent. Then, working frequency and class of emission specified at DSC-60① are set.
4. DSC-60① receives acknowledge back signal via radiotelephone.	Working frequency and class of emission specified at DSC-60① are set.	
Both communication frequency and class of emission are already set on the FS-1562 ① and FS-1562②, so you may begin communications.		

1.5 Interpreting Call Displays

This paragraph provides the information necessary for interpreting receive and send calls.

1.5.1 Receive calls

Below are sample distress and individual receive calls. Content of other receive calls is similar to that of the individual call.

Distress call

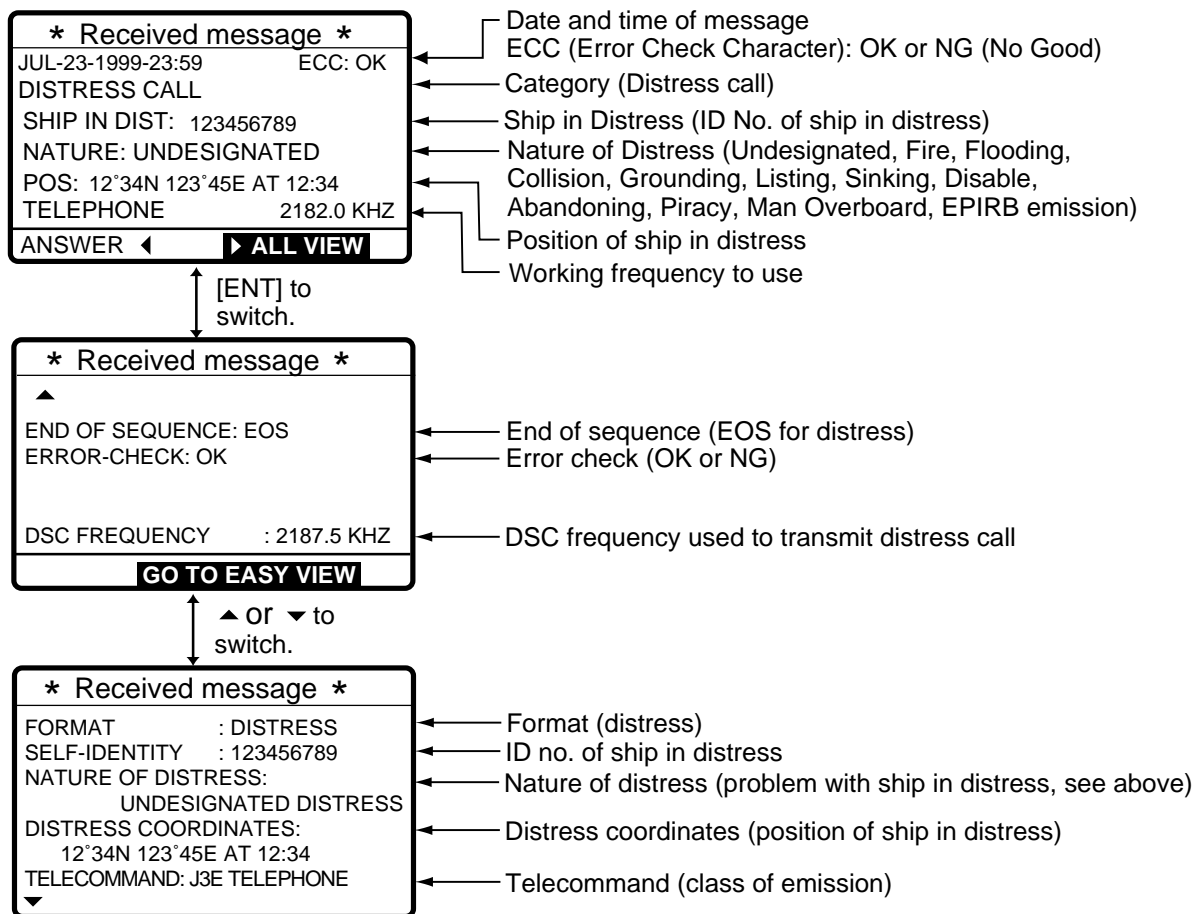

Individual call

```

* Received message *
JUL-23-1999-23:59      ECC: OK
INDIVIDUAL REQUEST
FROM SHIP:      123456789
ROUTINE
TELEPHONE      2182.0 KHZ
ANSWER ◀      ▶ ALL VIEW
  
```

- ← Date and time of message
- ← ECC (Error Check Character): OK or NG (No Good)
- ← Able to acknowledge ("Unable to acknowledge" and reason if unable)
- ← ID No. of sending station
- ← Category (Routine, Business, Safety, Urgency)
- ← Working frequency to use

Note: ANSWER is for replying to message.

↑ [ENT]
to switch.

```

* Received message *
▲ WORKING FREQ. :      2182 KHZ
END OF SEQUENCE: ACK. RQ
ERROR-CHECK: OK
DSC FREQUENCY TX: 2189.5 KHZ
RX: 2177.0 KHZ
GO TO EASY VIEW
  
```

- ← Working frequency to use
- ← End of sequence (ACK. BQ or ACK. RQ)
- ← Error check (OK or NG)
- ← DSC frequency used

↑ ▼ or ▲
to switch.

```

* Received message *
FORMAT      : INDIVIDUAL
ADDRESS     : 987654321
CATEGORY    : ROUTINE
SELF-IDENTITY : 123456789
1ST TELECOMMAND: J3E TELEPHONE
2ND TELECOMMAND: NO INFORMATION
▼
  
```

- ← Format (individual)
- ← ID of your station
- ← Category (Routine, Business, Safety, Urgency)
- ← ID of sending station
- ← 1st Telecommand (class of emission)
- ← 2nd Telecommand (class of emission)

1.5.2 Send calls

Below are sample distress and individual send calls. Content of other send calls is similar to that of the individual call.

Distress call

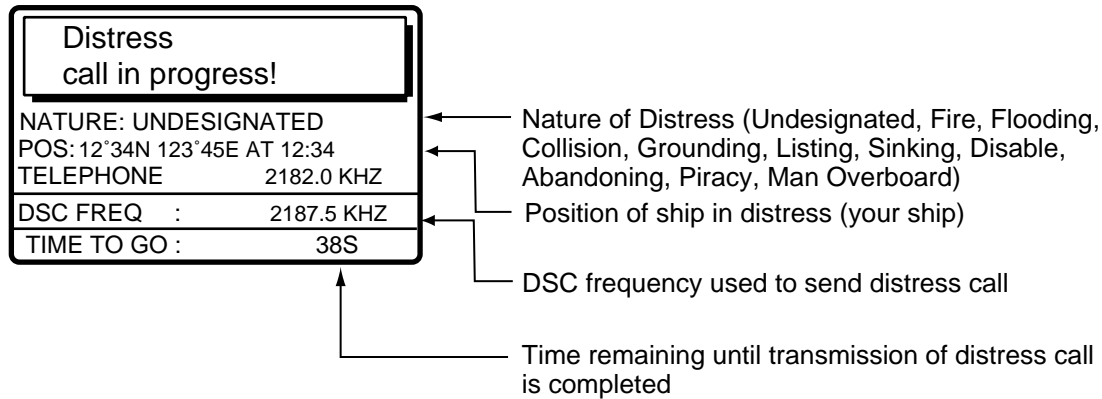

Individual call

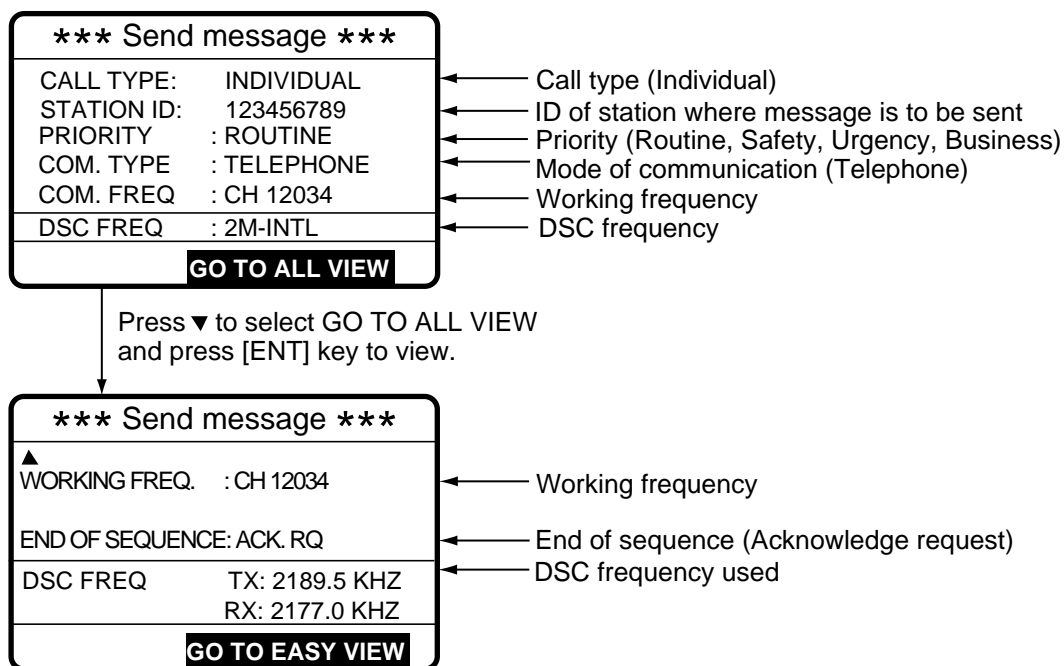

1.6 Remote Control of SSB Radiotelephone

SSB output power at transmission of distress alert

When the [DISTRESS] button is pressed, the output power of the FURUNO SSB radiotelephone is automatically set to maximum, even if it is set for minimum.

Keyboard lock at the SSB radiotelephone

The keyboard of the FURUNO SSB radiotelephone is automatically locked while a DSC message is being transmitted.

- Distress alert or distress relay transmitted (transmission time about 40 seconds)
The keyboard is locked until the transmission of the distress alert or distress relay is completed.
- Call other than distress is transmitted (transmission time about 8 seconds)
Press the [CANCEL] key to unlock the keyboard.

2. OPERATIONAL OVERVIEW

2.1 Controls, LED Description

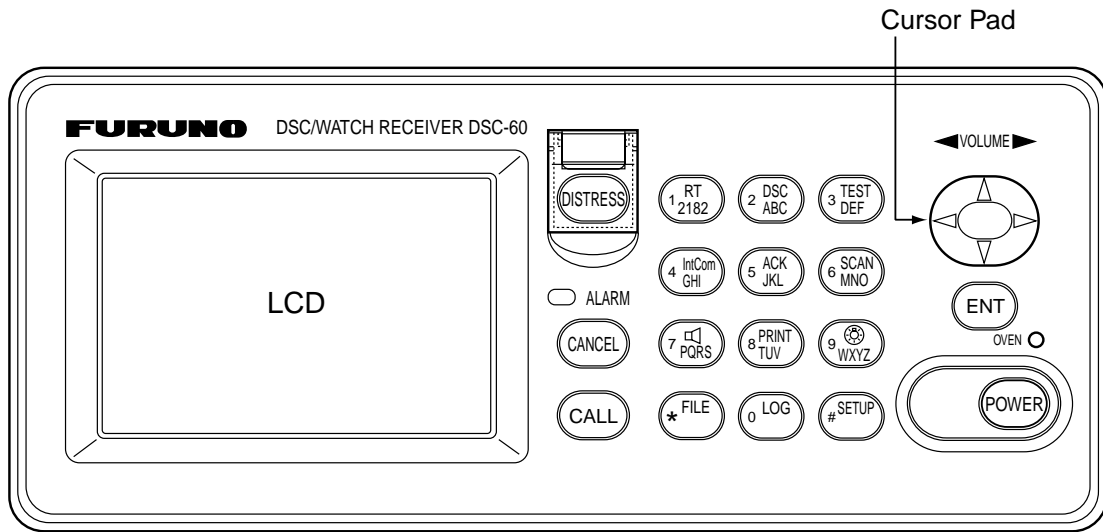

Control, LED description

Control	Function
POWER switch	Turns the power on/off.
DISTRESS button	Press and hold down the button more than three seconds to transmit the distress alert. When pressed it initially flashes, and lights up if the button is pressed more than three seconds. It stays lit until your ship receives the distress acknowledge message. The distress alert will not be transmitted if the button is pressed less than three seconds.
CALL key	Transmits calls other than distress.
Cursor Pad	Selects items on menus; adjusts loudspeaker volume (64 levels) on the DSC standby screen. (The distress and urgency alarms are received at maximum volume regardless of current loudspeaker volume setting.)
ENT key	Registers key input.
CANCEL key	<ul style="list-style-type: none"> • Cancels wrong data. • Restores previous menu. • Returns to DSC standby screen from other screen. • Silences audio alarm (distress or routine). • Cancels transmission, printing. • Erases error message.
1/ RT/2182 key	<ul style="list-style-type: none"> • Switches from the DSC standby screen to the radiotelephone setting screen. • Switches between J3E and 2182.0 kHz on radiotelephone setting screen.
2/DSC key	Switches from the radiotelephone setting screen to the DSC standby screen.
3/TEST key	Executes daily test.
4/IntCom key	Turns intercom with radiotelephone on/off, from the radiotelephone setting screen.
5/ACK key	Switches automatic and manual acknowledge alternately at the DSC standby screen.
6/SCAN key	Starts/stops scanning of DSC routine frequencies at the DSC standby screen.
7/🔊 key	<ul style="list-style-type: none"> • Turns loudspeaker on/off. • Silences buzzer. <p>Note that this key does not silence the distress or urgency alarm.</p>
8/PRINT key	Prints current screen and test results.
9/☀ key	Adjusts keyboard backlighting and LCD contrast.
*/FILE key	Opens the send message file from the DSC standby screen, to send stored message.
0/LOG key	Opens the Tx/Rx log file from the DSC standby screen.
#/SETUP key	Opens the Setup menu from the DSC standby screen.
ALARM lamp	<ul style="list-style-type: none"> • Flashes in red for distress or urgency call. • Flashes in green (more rapidly) for safety or routine call.
OVEN lamp	Lights (in green) when oven power is on.

2.2 Turning the Power On/Off

Press the [POWER] switch at the right-hand side of the equipment to turn the power on or off. Whenever the power is applied the DSC standby screen appears.

2.3 DSC Standby Screen, Radiotelephone Setting Screen and Their Indications

2.3.1 DSC standby screen

The DSC standby screen appears by pressing the [2/DSC] key. This is where you begin all calling operations.

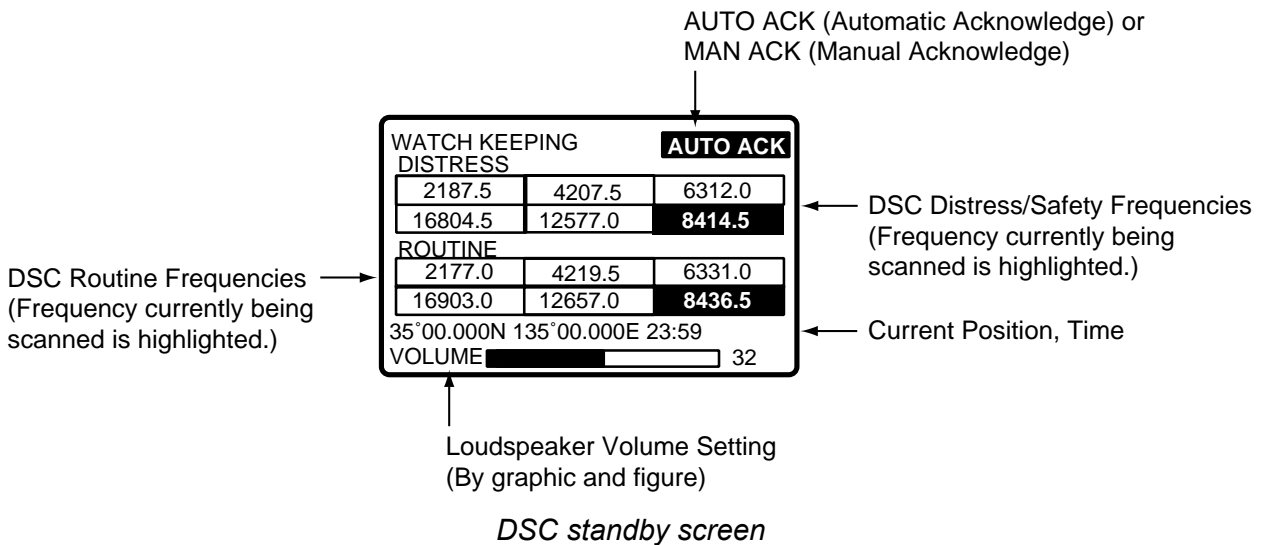

2.3.2 Radiotelephone setting screen

The radiotelephone setting screen appears by pressing the [1/ RT/2182] key. This is where you set up the radiotelephone.

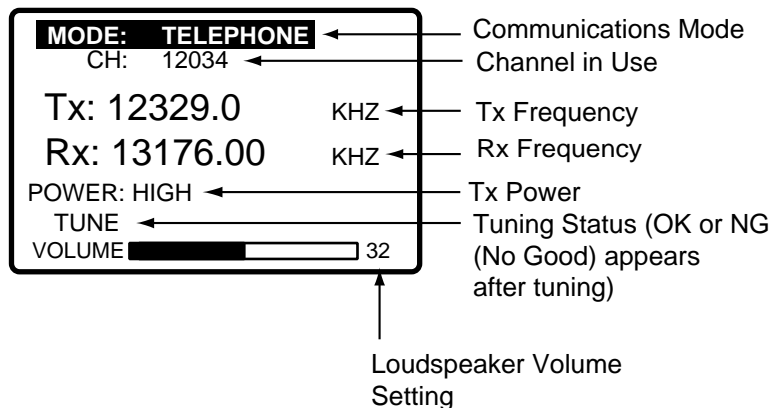

2.4 Panel Backlighting and LCD Contrast

1. At the DSC standby screen or radiotelephone setting screen, press the [9/☼] key. The following display appears.

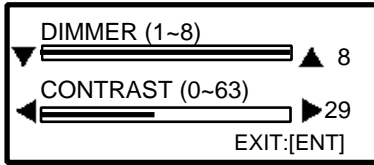

2. Use ▲ to increase the backlighting; ▼ to lower it. Current backlighting setting is shown in both digital and analog indications below DIMMER.
3. Use ◀ to lower the contrast; ▶ to raise it. Current contrast setting is shown in both digital and analog indications below CONTRAST.
4. Press the [ENT] key to finish and return to the screen previously in use.

2.5 Loudspeaker, Buzzer On/Off

1. Display the DSC standby screen or radiotelephone setting screen.
2. Press the [7/🔊] key to turn the loudspeaker, buzzer on or off. The message SOUND: ON or SOUND: OFF appears with each pressing of the key. The indication OFF appears at the lower-right side of the DSC standby and radiotelephone setting screens when the loudspeaker is turned off.

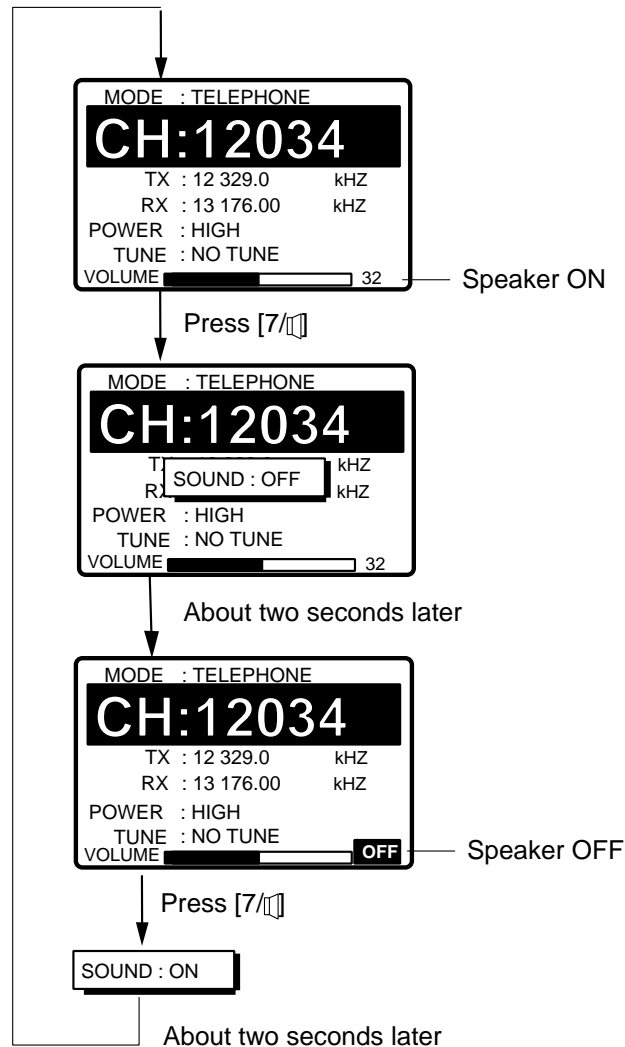

3. When the loudspeaker is on, press ◀ to lower the volume; ▶ to raise it. The setting range is 0 to 63. Current volume setting is shown by both bar graph and numeric at the bottom of the display.

2.6 Starting, Stopping Scanning DSC Routine Frequencies

Press the [6/SCAN] key at the DSC standby screen to start or stop scanning DSC routine frequencies. The DSC routine frequencies to scan can be selected through the menu. Note that scanning of DSC distress frequencies cannot be stopped.

The screenshot shows the DSC standby screen with the following content:

- WATCH KEEPING **AUTO ACK**
- DISTRESS
- 2187.5 4207.5 6312.0
- 6804.5** 12577.0 8414.5
- ROUTINE
- 2177.0 4219.5 6331.0
- 16903.0** 12657.0 8436.5
- 35°00.000N 135°00.000E 23:59
- VOLUME 32

Annotations:

- An arrow points from the text "DSC routine frequency currently being scanned is highlighted." to the frequency **16903.0** in the ROUTINE list.
- An arrow points from the text "DSC distress frequency currently being scanned is highlighted." to the frequency **6804.5** in the DISTRESS list.

2.7 Automatic Acknowledge On/Off

The automatic acknowledge feature, when turned on, automatically transmits the acknowledge back (ACK BQ) signal to the sender when an individual, position, PSTN or polling call is received. It can be turned on or off at the DSC standby screen by pressing the [5/ACK] key. The message ACK: AUTO or ACK: MANUAL appears at the top-right corner of the DSC standby screen with each press of the key.

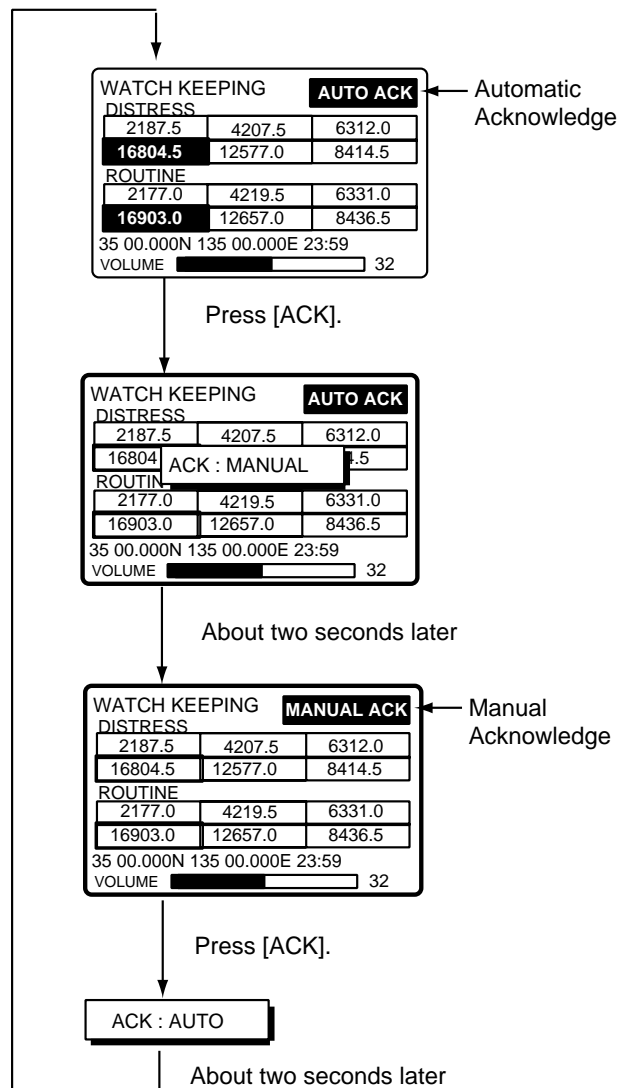

2.8 Intercom On/Off

The built-in intercom permits voice communications between the DSC-60 and the SSB radiotelephone to which it is connected.

1. Display the radiotelephone setting screen.
2. Off hook the handset.
3. Press the [4/IntCom] key. You can begin communications with the SSB radiotelephone.

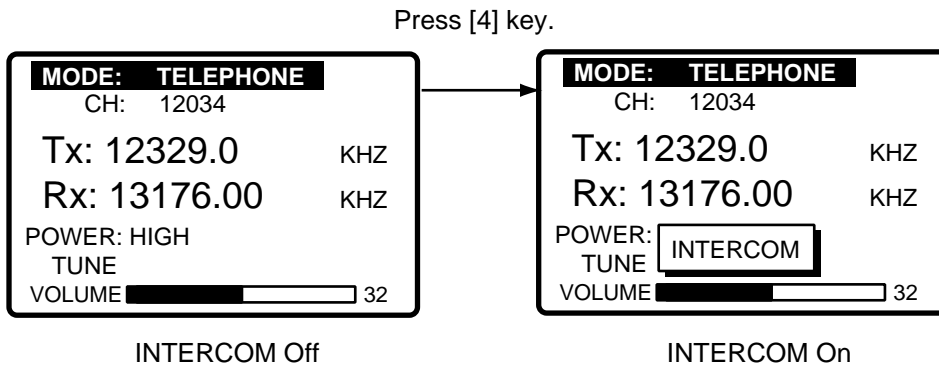

4. Hang up the handset when finished with communications to turn the intercom off. The indication INTERCOM disappears from the radiotelephone setting screen when the intercom is turned off.

Note: If you are called from other onboard SSB radiotelephone, three beeps sound. Off the handset and begin communications.

2.9 Selection of On-screen Items

Menu and calling operations are executed by selecting on-screen items. The example below shows how to select items and options from the Alarm setup menu.

1. Press the [# / SETUP] key to display the Setup menu.

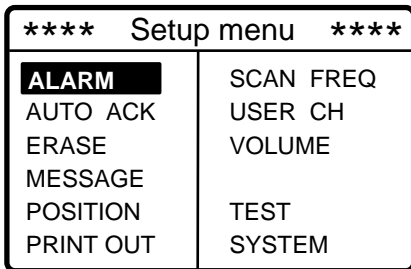

2. Use the Cursor Pad to select a menu and then press the [ENT] key. For example, select the ALARM menu.

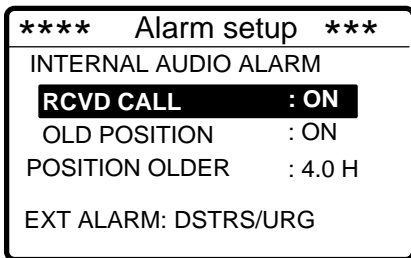

3. Use ▲ or ▼ to select menu item desired and press the [ENT] key. For example, select RCVD CALL. The following window appears, superimposed on the main window.

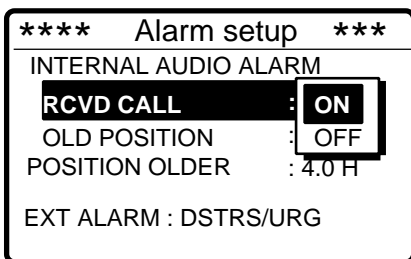

4. Use ▲ or ▼ to select option.
5. Press the [ENT] key to register your selection and the [CANCEL] key twice to return to the DSC standby screen.

2.10 Manual Entry of Position and Time

If there is no EPFS (Electronic Position-Fixing System) connected to the DSC-60 or the EPFS connected is inoperative, manually enter position and time as follows:

1. At the DSC standby screen, press the [#/SETUP] key to display the Setup menu.

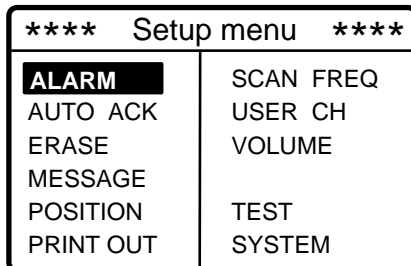

2. Select POSITION and press the [ENT] key to display the Position setup menu.

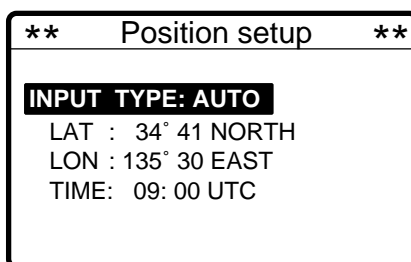

3. Press the [ENT] key to open the INPUT TYPE menu.

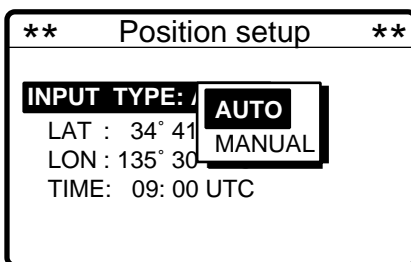

Note 1: If, when AUTO is selected, input from the navigator is interrupted the message “EPFS error!” appears. If this occurs check the navigator.

Note 2: If, when MANUAL is selected, the message “Warning: Update position” appears at set intervals to ask you to update position. For further details see page 7-2.

4. Press ▼ to select MANUAL and press the [ENT] key.
5. Press the [ENT] key to open the latitude entry window.

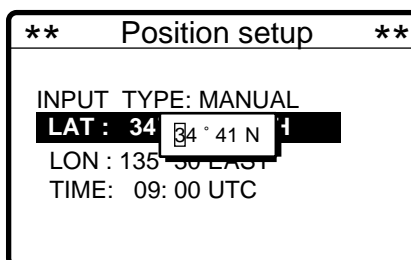

Note: Use ▼ to switch from North to South and vice versa.

6. Enter latitude in four digits and press the [ENT] key.
7. Press the [ENT] key to open the longitude entry window.

```
** Position setup **  
  
INPUT TYPE: MANUAL  
LAT : 34° 41 NORTH  
LON : 135 135°00 E  
TIME: 09:00 UTC
```

Note: Use \blacktriangledown to switch from East to West and vice versa.

8. Enter longitude in five digits and press the [ENT] key.
9. Press the [ENT] key to open the time entry window.

```
** Position setup **  
  
INPUT TYPE: MANUAL  
LAT : 34° 41 NORTH  
LON : 135° 30 EAST  
TIME: 09:12:34
```

10. Enter UTC time and press the [ENT] key. The Setup menu appears.

2.11 Remote Control of FURUNO SSB Radiotelephone

A FURUNO SSB radiotelephone can be controlled from the radiotelephone setting screen, which may be displayed by pressing the [1/ RT/2182] key. You can enter desired frequency by designating channel as below or entering Tx and Rx frequencies as on the next page. The handset must be off hook to set the radiotelephone.

Note: To set the SSB radiotelephone to 2182 kHz/J3E, press the [1/ RT/2182] key more than 2 sec.

Mode selection

1. Press the [1/ RT/2182] key to display the radiotelephone setting screen.
2. Select the MODE field with the Cursor Pad and press the [ENT] key.
3. Select mode desired and press the [ENT] key.

TELEPHONE: Telephone

NBDP/DSC: NBDP Terminal, DSC Terminal

FAX: Facsimile

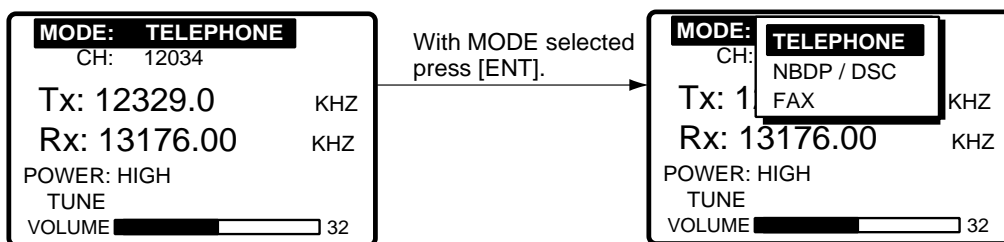

Channel selection

1. Select the CH field and press the [ENT] key.

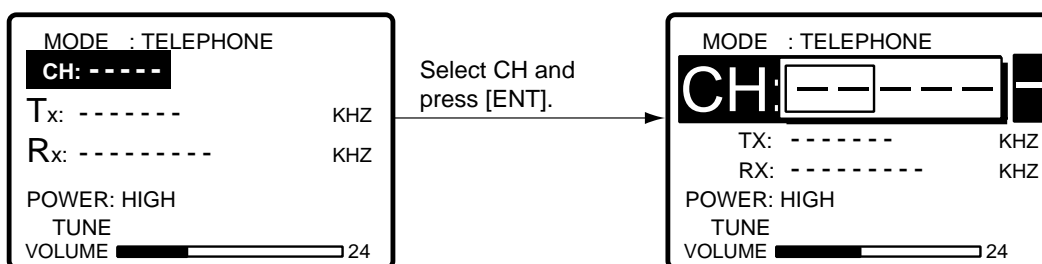

2. Enter channel with Cursor Pad as follows:
 - a) Use ▲ or ▼ to set band (MHz) 2, 4, 6, 8, 12, 16, 18, 24, 25. Note the band and channel may also be entered directly from the keyboard.
 - b) Press ▶.
 - c) Use ▲ or ▼ to set channel.
 - d) Press the [ENT] key. The Tx and Rx frequencies of the channel entered appear.

Select digit (band, channel) with ◀ or ▶.

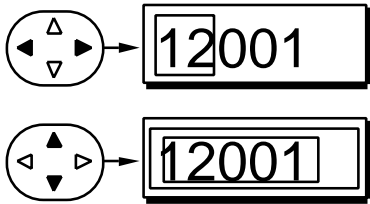

Setting Range

ITU Band: 2/4/6/8/12/16/18/24/25
User Band: 01-029
ITU Channel: XX001 - XX193
User Channel: XXX01 - XXX99

Set with ▲ or ▼.

Tx/Rx frequency selection

Select the Tx or Rx field and press the [ENT] key. Enter desired frequency with the numeric keys. Press the [ENT] key to finish.

Note: If you enter the Tx frequency, the same frequency is entered to the Rx frequency.

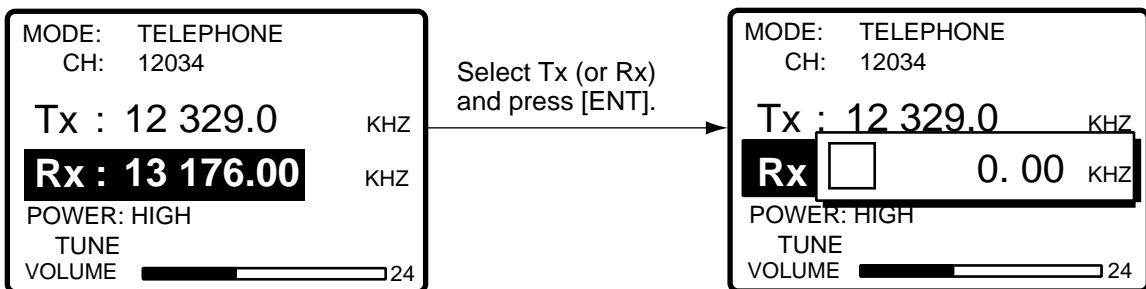

Power selection

Select the POWER field with the Cursor Pad and press the [ENT] key. Select power desired among HIGH, MID and LOW with the Cursor Pad and press the [ENT] key.

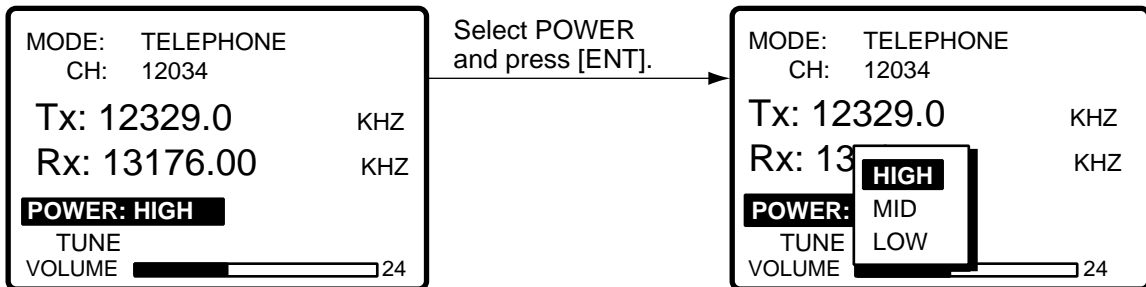

Note: Some FURUNO SSB radiotelephones do not provide the power selection HIGH, MID or LOW.

Tuning

Select the TUNE field with the Cursor Pad and press the [ENT] key. Tuning is automatically executed, showing TUNING while tuning. The results are shown as TUNE: OK or TUNE: NG (No Good).

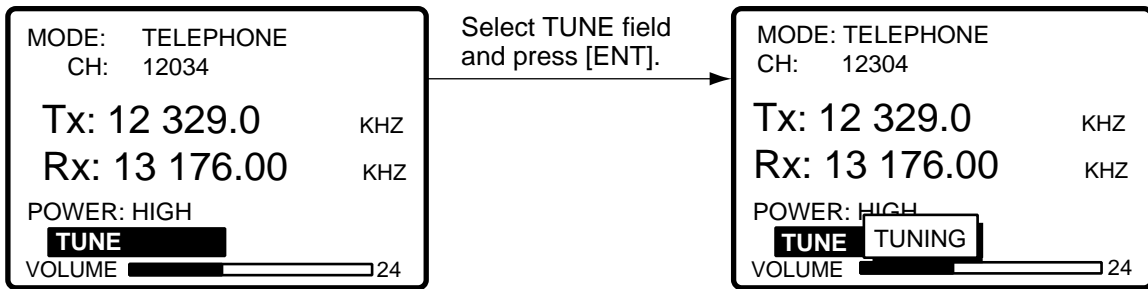

3. DISTRESS OPERATIONS

3.1 Sending Distress Alert

3.1.1 Sending distress alert by DISTRESS button

GMDSS ships carry a DSC terminal with which to transmit the distress alert in the event of a life endangering situation onboard ship. A coast station receives the distress alert and sends the distress alert acknowledge message to the ship in distress. Then, voice communications between the ship in distress and coast station begins, via the radiotelephone.

Transmission of the distress alert and receiving of distress alert acknowledgement are completely automatic - simply press the [DISTRESS] button to initiate the sequence.

1. Open the DISTRESS button cover and press and hold down the [DISTRESS] button more than three seconds. The button flashes in red and the buzzer sounds rapidly. The display shows the contents of the distress alert call: your ship's nature of distress and position, time, and DSC frequency used to transmit the alert.

The number of seconds to continue pressing the [DISTRESS] button appear at the bottom of the display. The buzzer sounds continuously when the button has been pressed three seconds. You can release the button at that time.

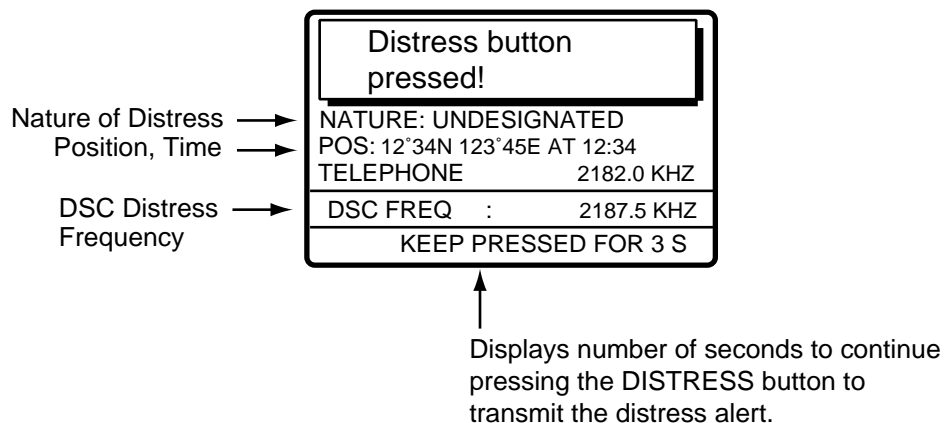

2. The [DISTRESS] button lights and the display changes as at the top of the next page. It takes about 35-40 seconds to complete transmission of the distress alert, and the number of seconds until transmission is completed is shown at the bottom of the display.

At this time the output power of the radiotelephone is automatically set to maximum.

Distress call in progress!	
NATURE: UNDESIGNATED	
POS: 12°34N 123°45E AT 12:34	
TELEPHONE	2182.0 KHZ
DSC FREQ :	2187.5 KHZ
TIME TO GO :	38S



Time to go until distress alert transmission is completed.

The equipment sets up as follows:

- Equipment goes into Alert condition.
- Distress message contains current position and time.
- Scanning is stopped and Distress watch receiver sets distress frequency.
- RT/NBDP remote function activated.
- Timer countdowns time remaining until distress alert transmission is completed.
- The only keys operative are [7/SP] and [9/DIMMER].

- After the distress alert has been sent the display changes as below. This is where the equipment waits to receive the distress acknowledge message from a coast station. It takes about one minute to three minutes. (The [DISTRESS] button remains lit until the DSC-60 receives the distress acknowledge message from a coast station.) The timer counts down the number of minutes to wait, from 3.5 to 4.5 minutes, randomly set.

At this time the DSC-60 cannot receive any messages except the distress alert acknowledge message. Distress message is recorded in the Tx log.

Waiting for distress acknowledgement.	
NATURE: UNDESIGNATED	
POS: 12°34N 123°45E AT 12:34	
TELEPHONE	2182.0 KHZ
DSC FREQ :	2187.5 KHZ
TIME TO GO:	3M 10S

- When the distress acknowledge call is received the audio alarm sounds and the display changes as below.

Distress acknowledge call received.	
FROM COAST: 001234567	
SHIP IN DIST: 123456789	
NATURE: UNDESIGNATED	
POS: 12°34N 123°45E AT 12:34	
TELEPHONE	2182.0 KHZ
STOP ALARM	

Note: If you do not receive the distress alert acknowledge call, the DSC-60 re-transmits the distress alert and then awaits the distress alert acknowledge call. This is repeated until the distress alert is acknowledged.

- Silence the alarm with the [CANCEL] or [ENT] key. The receive message appears as in the figure below.

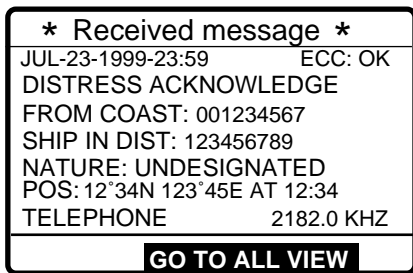

- Communicate with the coast station via radiotelephone, which is automatically set to working frequency and class of emission (telephone) specified in the distress acknowledge message.
 - Say MAYDAY three times.
 - Say "This is ... " name of your vessel and call sign three times.
 - Give nature of distress and assistance needed.
 - Give description of your vessel (type, color, number of persons onboard, etc.).
- The coast station replies as follows:
 - MAYDAY.
 - Name of your vessel and call sign three times.
 - This is " ... " coast station name.
 - RECEIVED
 - MAYDAY

3.1.2 Sending distress alert with nature of distress specified

If you have the time to designate the nature of distress, send the distress alert as follows:

- At the DSC standby screen, press the [CALL] key.
- Press the [ENT] key and the display changes as below.

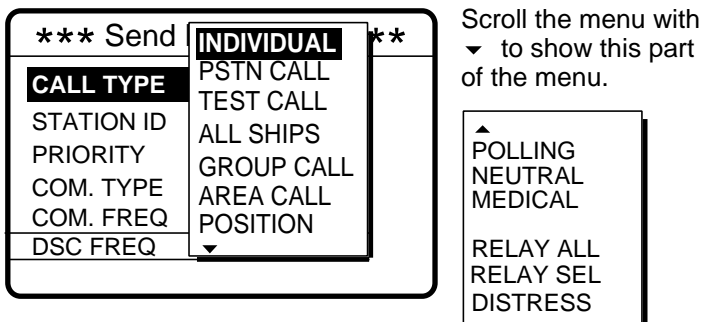

- Select DISTRESS from the menu and press the [ENT] key.

- Press the [ENT] key to open the NATURE menu.

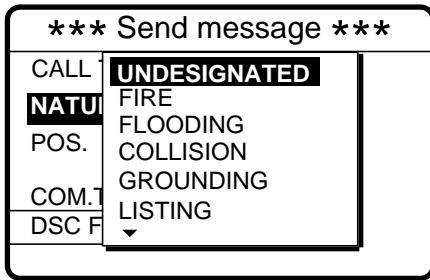

Use ▼ to scroll menu.

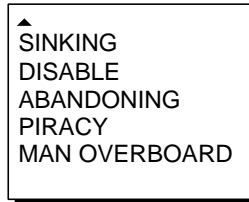

- Select nature of distress and press the [ENT] key.
- Press the [ENT] key to open the POS menu. This is where you enter your position, automatically or manually.

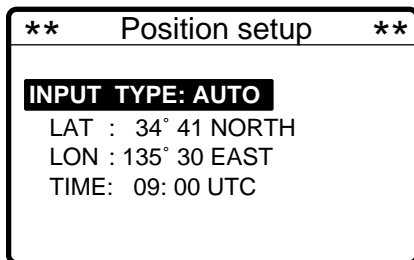

- Press the [ENT] key to open the INPUT TYPE menu.

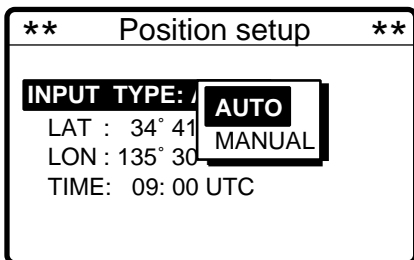

- Press ▲ to select AUTO or ▼ to select MANUAL and press the [ENT] key. If you selected AUTO go to step 15. For manual go to step 9.
- Press the [ENT] key to open the latitude entry window.

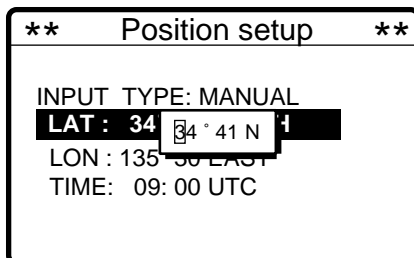

Note: Use ▼ to switch from North to South and vice versa.

10. Key in latitude in four digits and press the [ENT] key.
11. Press the [ENT] key to open the longitude entry window.

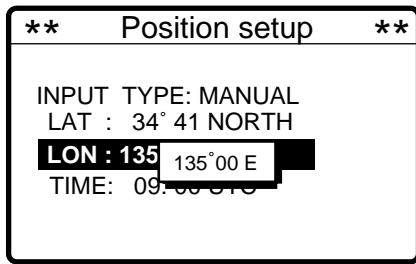

Note: Use \blacktriangledown to switch from East to West and vice versa.

12. Key in longitude in five digits and press the [ENT] key.
13. Press the [ENT] key to open the time entry window.

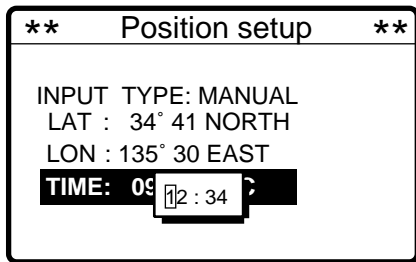

14. Key in UTC time and press the [ENT] key.
15. The SEND MESSAGE screen is redisplayed. Press the [ENT] key to open the COM. TYPE menu.

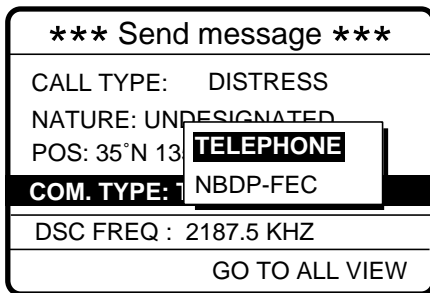

16. Select TELEPHONE and press the [ENT] key. (Telephone is the usual mode, however NBDP may also be used.)

17. Press the [ENT] key to open the DSC FREQ menu.

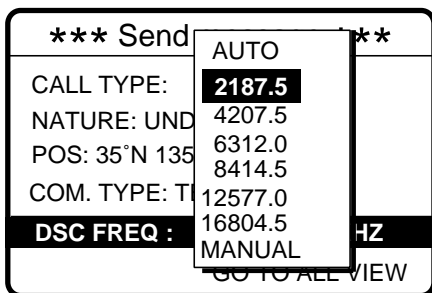

18. Select a DSC frequency and press the [ENT] key. (AUTO retransmits the distress alert on 2 MHz, 8 MHz, 16 MHz, 4 MHz, 6 MHz and 2 MHz in sequence if the distress alert is not acknowledged and MANUAL is for manual selection of frequency at the radiotelephone when there is “remote error.”)

DSC	SSB radiotelephone	NBDP-FEC
2187.5 kHz	2182.0 kHz	2174.5 kHz
4207.5 kHz	4125.0 kHz	4177.5 kHz
6312.0 kHz	6215.0 kHz	6268.0 kHz
8414.5 kHz	8291.0 kHz	8376.5 kHz
12577.0 kHz	12290.0 kHz	12520.0 kHz
16804.5 kHz	16420.0 kHz	16695.0 kHz

19. The display changes as below. You can see the contents of the distress message by pressing the [ENT] key.

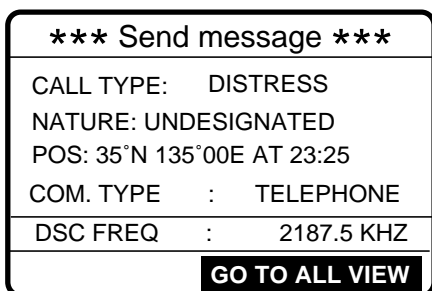

20. Press the [DISTRESS] button to send the distress alert.

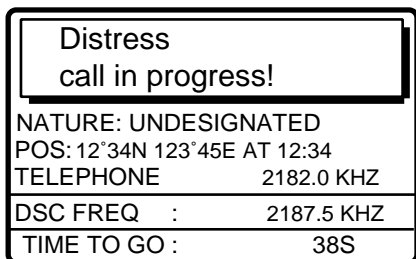

21. Follow steps 3-7 on page 3-2 and 3-3.

3.2 Sending Distress Relay to All Ships

When you receive a distress call from another ship, the audio alarm sounds and the message "Distress call received." appears on the display. Press the [CANCEL] key to silence the audio alarm. Monitor the distress frequency. The procedure for relaying the distress alert depends on if the alert was received on MF or HF band.

3.2.1 Distress alert received on MF band

Do the following:

- Continue watching on 2182 kHz. Wait for coast station to acknowledge the distress call. Distress communications continues until "SEELONCE FINI" is announced.
- After distress communications are completed, relay the distress alert. You do not have to receive distress acknowledge from coast station; you can relay the distress call when you are near the ship in distress.
- Receive distress acknowledge signal for ship in distress. You do not have to wait for acknowledgement from coast station; you may only send the relay the distress call when you are near the ship in distress.

If you do not receive the distress acknowledge within three minutes follow the flow chart on the next page to determine if you should send the distress.

Flow chart for determining whether to relay distress alert

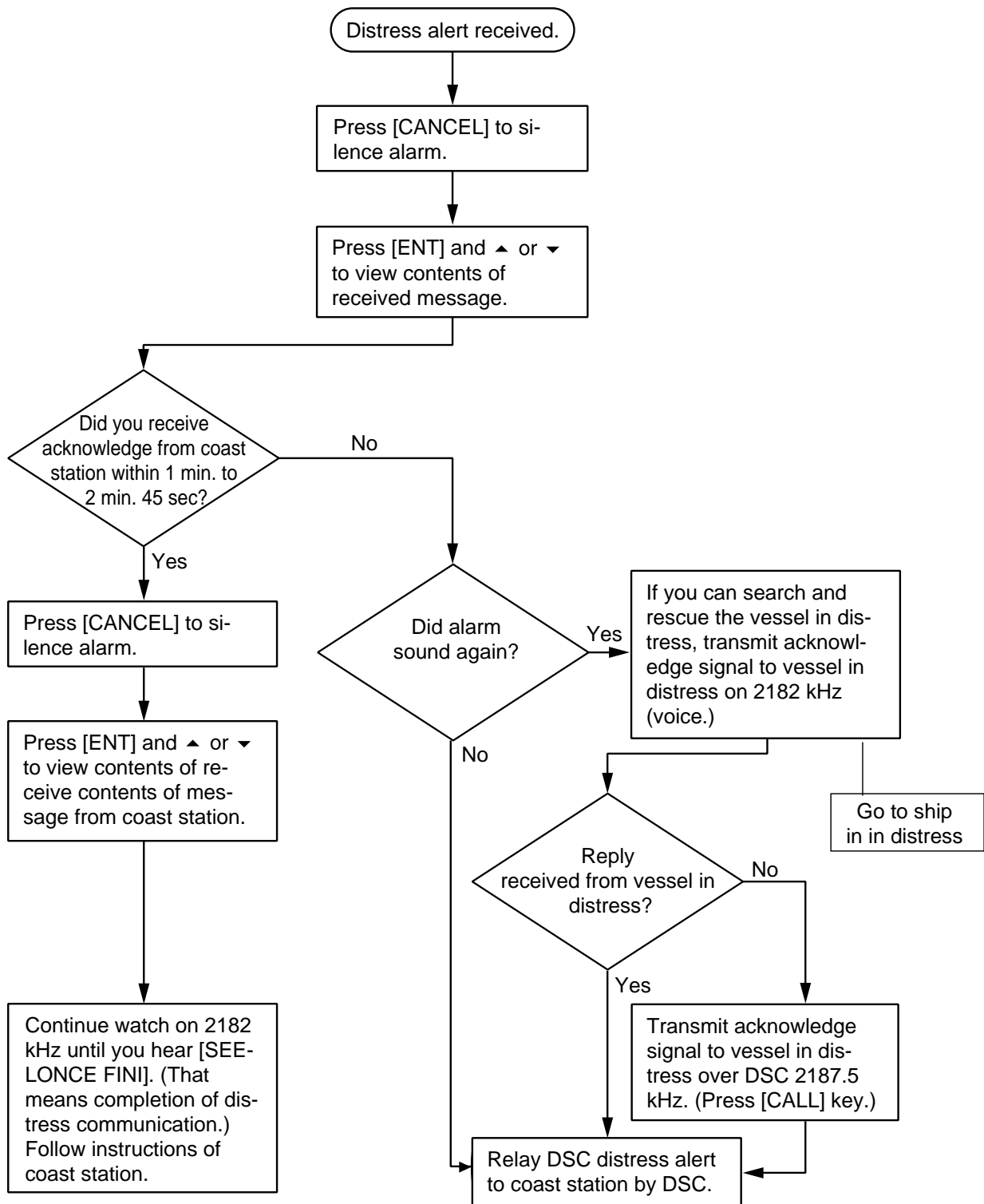

Relay DSC distress alert to coast station over HF band (8414.5 kHz). After relaying distress, wait for acknowledge from coast station. (For All Ship call: wait for radiotelephone, For individual call: wait over DSC.)

Sending the distress relay on MF band

First confirm whether your vessel should send the distress acknowledge signal, by following the flow chart on page 3-8. If your ship meets those requirements do the following:

1. The audio alarm sounds and the display shows the message "Distress call received." when your ship receives a distress call.

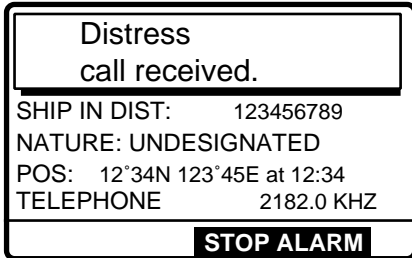

2. Press the [CANCEL] key to silence the audio alarm, and the display changes as below.

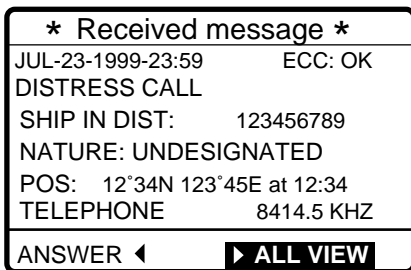

3. Press ◀ to choose ANSWER and press the [ENT] key.
4. Press the [ENT] key to open the CALL TYPE menu.

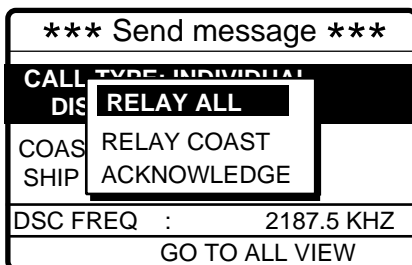

5. Select RELAY COAST (or RELAY ALL if you don't know the coast where to send the distress relay) and press the [ENT] key. Press the [ENT] key to open the COAST ID entry window.

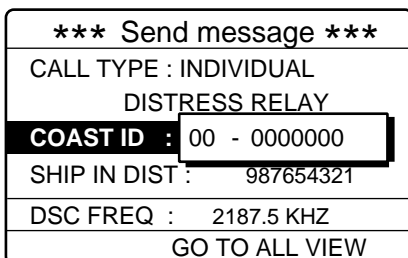

6. Key in coast ID where to send the distress alert and press the [ENT] key.

7. Press the [ENT] key to open the DSC FREQ. menu.

*** Send		2187.5	**
CALL TYPE		4207.5	
DIST		6312.0	
COAST ID:		8414.5	
SHIP IN DIST		12577.0	
		16804.5	
DSC FREQ	MANUAL	<HZ	
GO TO ALL VIEW			

8. Select appropriate frequency and press the [ENT] key.

Note: Selection of frequency not necessary if frequency shown in step 7 is appropriate.

9. Press the [CALL] key to relay the distress call.

Note: If a coast station acknowledges the distress alert call before the timer counts to zero, press the [CANCEL] key to cancel your call. Further, If the call key is pressed before five minutes has elapsed the time to wait until the distress relay is sent is shown at the bottom of the display.

*** Send message ***	
CALL TYPE	: INDIVIDUAL
DISTRESS RELAY	
COAST ID:	001234567
SHIP IN DIST:	123456789
DSC FREQ	: 2187.5 KHZ
GO TO ALL VIEW	

10. While the distress relay all call is being sent the display shows the following.

Distress relay coast call in progress!	
COAST ID:	001234567
SHIP IN DIST:	123456789
DSC FREQ	: 8414.5 KHZ
TIME TO GO	: 25S

11. The equipment then waits for acknowledgement of the distress relay, showing the following. If the distress relay is not acknowledged within five minutes the message "No response. Try relay again." appears. If this occurs send the relay again.

Waiting for distress relay acknowledge.	
COAST ID	: 001234567
SHIP IN DIST	: 123456789
DSC FREQ	: 8414.5 KHZ
TIME TO GO	: 4M59S

- When the distress relay is acknowledged the audio alarm sounds and the display changes as below.

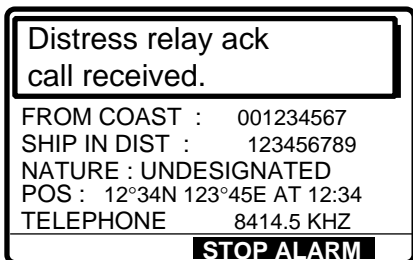

- Press the [CANCEL] key to silence the audio alarm, and the display below appears.

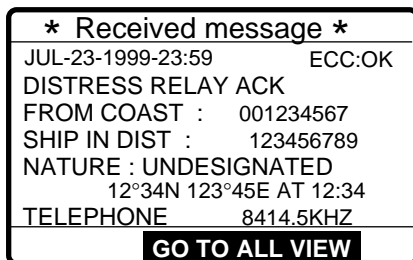

Sending distress acknowledge

Send the distress acknowledge to the ship in distress when the coast station does not acknowledge the distress call and you are able to assist the ship in distress.

- The audio alarm sounds and the display shows the message "Distress call received." when your ship receives a distress call.



- Press the [CANCEL] key to silence the audio alarm, and the display changes as below.

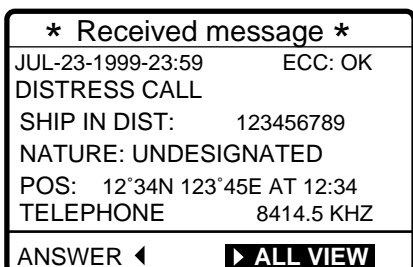

- Press ◀ to choose ANSWER and press the [ENT] key.

4. Press the [ENT] key to open the CALL TYPE menu.

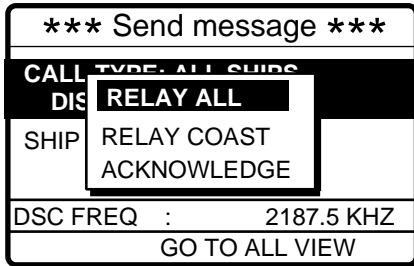

The option ACKNOWLEDGE does not appear in the following cases:
a) Distress alert received on HF band.
b) If, on MF band, more than 2 min. 45 sec. elapses after the distress alert is received.

5. Select ACKNOWLEDGE and press the [ENT] key. The following display appears.

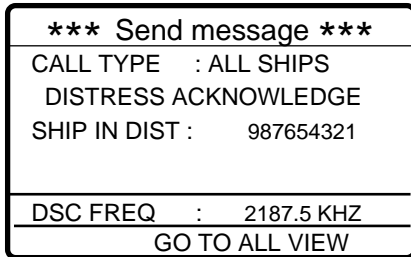

6. Press the [CALL] key to send the distress acknowledge call to the ship in distress.

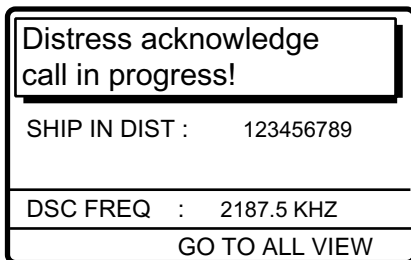

3.2.2 Distress alert received on HF band

If you receive a distress signal on HF band, the ALARM lamp lights and the audio alarm sounds. Press the [CANCEL] key to silence the audio alarm. Wait for the distress acknowledge from a coast station. If you do not receive it within three minutes do one of the following:

- Watch on the distress frequency.
 - Relay the distress alert in the following cases.
 - You do not receive distress acknowledge call from coast station within three minutes after receiving distress call.
 - You have not received distress relay from other ship.
 - You cannot receive distress communications from other ship over radiotelephone.
1. The audio alarm sounds and the display changes as below when a distress call is received.

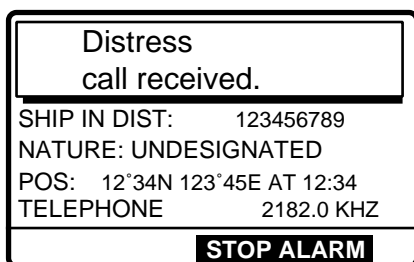

2. Press the [CANCEL] key to silence the audio alarm, and the display changes as below.

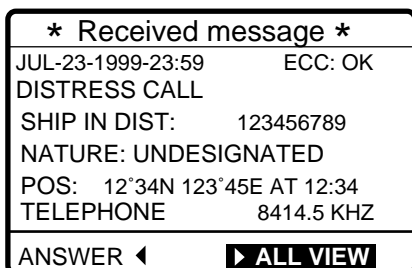

3. Select the display which shows GO TO ALL VIEW, press ◀ to choose ANSWER and press the [ENT] key.
4. Press the [ENT] key to open the CALL TYPE menu.

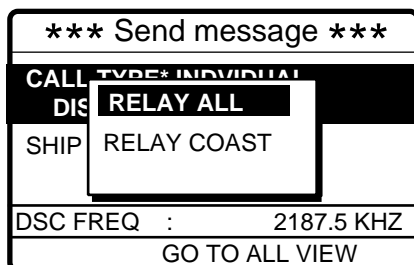

5. Select RELAY COAST (if you know the ID of the nearest coast station) and press the [ENT] key.

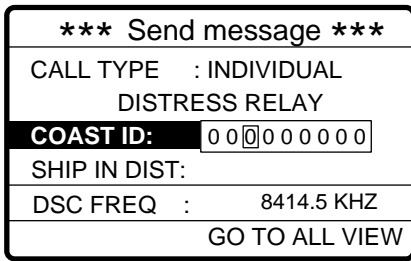

- Key in ID of coast station where to send the call and press the [ENT] key.
- Press the [ENT] key to open the DSC FREQ. menu.

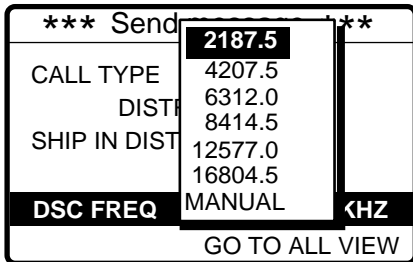

- Select appropriate frequency and press the [ENT] key.
Note: Selection of frequency not necessary if frequency shown in step 7 is appropriate.

- The display changes as below. Press the [CALL] key to relay the distress call.
Note: If a coast station acknowledges the distress alert call before the timer counts to zero, press the [CANCEL] key to cancel your call. Further, If the call key is pressed before five minutes has elapsed the time to wait until the distress relay is sent is shown at the bottom of the display.

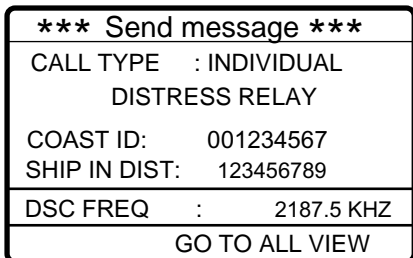

- While the distress relay all call is being sent the display shows the following.

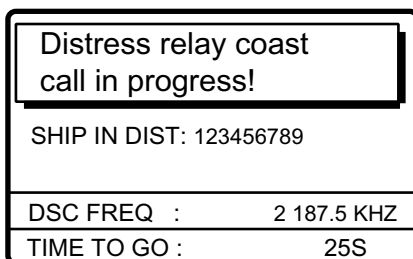

- After the call is transmitted the message “Waiting for distress relay acknowledge!” appears. When you receive acknowledgement from the coast station communicate with the coast station.

3.3 Sending Distress Relay on Behalf of a Ship in Distress

3.3.1 Sending distress relay to coast station

You may send the distress relay to a coast station on behalf of a ship in distress in the following cases:

- You are near the ship in distress and the ship in distress cannot transmit the distress alert.
- Another vessel requests you to transmit the distress relay.

1. Press the [CALL] key and press the [ENT] key.

*** Send **INDIVIDUAL** **

CALL TYPE	PSTN CALL
STATION ID	TEST CALL
PRIORITY	ALL SHIPS
COM. TYPE	GROUP CALL
COM. FREQ	AREA CALL
DSC FREQ	POSITION

If this part of the menu appears, use ▲ to scroll the menu.

▲	POLLING
	NEUTRAL
	MEDICAL
	RELAY ALL
	RELAY SEL
	DISTRESS

2. Select RELAY SEL and press the [ENT] key.

*** Send message ***

CALL TYPE: RELAY ALL

ID IN DIST

NATURE: UN 00000000

POS: 34°45N 15

COM. TYPE : TELEPHONE

DSC FREQ. : 2187.5 KHZ

GO TO ALL VIEW

3. Key in ID of ship in distress and press the [ENT] key. If you do not know the ID leave the ID menu as it is (all 0s showing).

*** Send message ***

CALL	UNDESIGNATED
ID IN I	FIRE
NATU	FLOODING
POS:	COLLISION
COM.	GROUNDING
DSC F	LISTING

Use ▼ to scroll menu.

▲	SINKING
	DISABLE
	ABANDONING
	PIRACY
	MAN OVERBOARD
	EPIRB EMISSION

- Select nature of distress and press the [ENT] key. (If you do not know the nature of distress, select UNDESIGNATED.) Press the [ENT] key to open the POS menu.

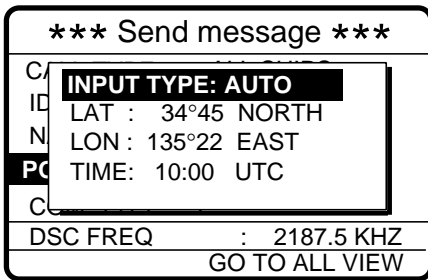

- Enter position. For automatic input, press the [ENT] key twice. For manual, press the [ENT] key to select MANUAL and press the [ENT] key. Enter latitude, longitude of ship in distress and time as follows:
 - Press ▼ to select LAT and press the [ENT] key. Enter latitude and press the [ENT] key.
 - Press ▼ to select LONG and press the [ENT] key. Enter longitude and press the [ENT] key.
 - Press ▼ to select TIME and press the [ENT] key. Enter UTC time and press the [ENT] key.
- Press the [ENT] key to open the COM. TYPE menu.

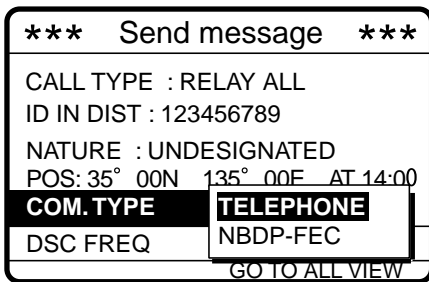

- Select TELEPHONE and press the [ENT] key. (NBDP may also be used.) Press the [ENT] key to open the DSC menu.

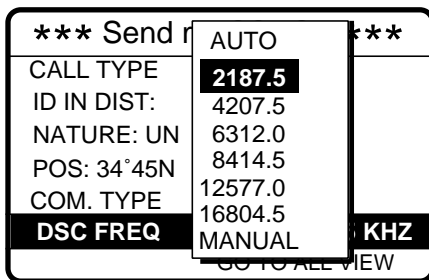

DSC	SSB radiotelephone	NBDP-FEC
2187.5 kHz	2182.0 kHz	2174.5 kHz
4207.5 kHz	4125.0 kHz	4177.5 kHz
6312.0 kHz	6215.0 kHz	6268.0 kHz
8414.5 kHz	8291.0 kHz	8376.5 kHz
12577.0 kHz	12290.0 kHz	12520.0 kHz
16804.5 kHz	16420.0 kHz	16695.0 kHz

- Select appropriate DSC frequency and press the [ENT] key. The display now looks something like the one at the top of the next page.

```

*** Send message ***
CALL TYPE : RELAY SEL
COAST ID : 001234567
ID IN DIST : NO INFO
NATURE : SINKING
POS : 12°34N 123°45
COM. TYPE : TELEPHONE
DSC FREQ : 8414.5 KHZ
GO TO ALL VIEW

```

9. Press the [CALL] key to send the call. The equipment then waits for acknowledgement of the distress relay.

```

Distress relay coast
call in progress!
TO COAST : 001234567
SHIP IN DIST : NO INFO
POS : 12°34N 123°45 AT 12:34
TELEPHONE 12290.0 KHZ
DSC FREQ : 8414.0 KHZ

```

10. The equipment then waits for acknowledgement of the distress relay, showing the following. Message. If the distress relay is not acknowledged within five minutes the message "No response. Try relay again." appears. If this occurs send the relay again.

```

Waiting for distress
relay acknowledge.
COAST ID : 001234567
SHIP IN DIST : 123456789
DSC FREQ : 8414.5 KHZ
TIME TO GO : 4M59S

```

11. The display shows the following message when the distress relay acknowledge call is received.

```

Distress relay ack
call received.
FROM COAST : 001234567
SHIP IN DIST : NO INFO
NATURE : SINKING
POS : 12°34N 123°45 AT 12:34
TELEPHONE 8414.5 KHZ
STOP ALARM

```

12. The audio alarm sounds; press the [CANCEL] key to silence the alarm. The following display appears.

```

* Received message *
JUL-23-1999-23:59 ECC:OK
DISTRESS RELAY ACK
FROM COAST : 001234567
SHIP IN DIST : NO INFO
NATURE : SINKING
POS : 12°34N 123°45 AT 12:34
TELEPHONE 8414.5 KHZ
GO TO ALL VIEW

```

3.3.2 Sending distress relay to all ships

This procedure sends the distress relay to all ships.

1. Press the [CALL] key.

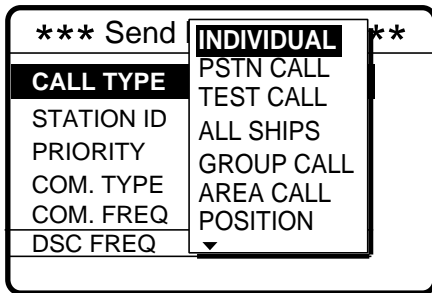

If this part of the menu appears, use ▲ to scroll the menu.

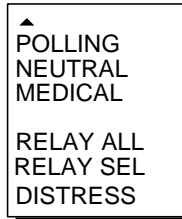

2. Select RELAY ALL and press the [ENT] key.
3. Press the [ENT] key to open the ID IN DIST menu.

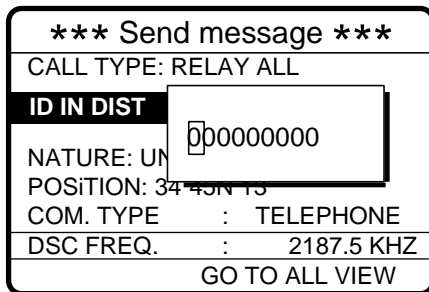

4. Key in ID of ship in distress (if known) and press the [ENT] key. (If you do not know the ID enter leave the ID menu as it is.)
5. Press the [ENT] key to open the NATURE menu.

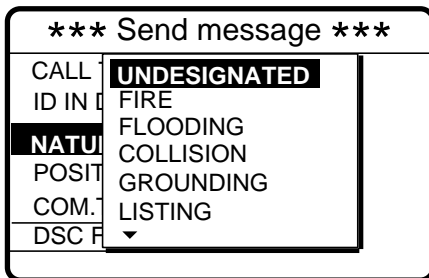

Use ▼ to scroll menu.

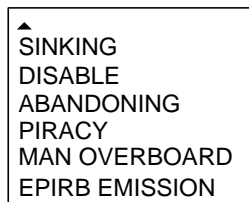

6. Select nature of distress (if known) and press the [ENT] key. (If you do not know the nature of distress, select UNDESIGNATED.)

- Press the [ENT] key to open the POS menu, where you enter the position of the ship in distress and time, manually or automatically.

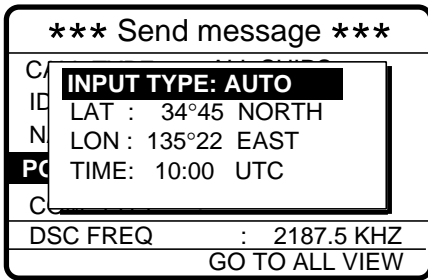

- To enter position and time automatically**, when you are near the ship in distress, press the [ENT] key, select AUTO, press the [ENT] key again and then go to step 9. **For manual input**, press the [ENT] key, select MANUAL and press the [ENT] key again. Enter position and time as follows:

 - Press ▼ to select LAT and press the [ENT] key. Enter latitude and press the [ENT] key.
 - Press ▼ to select LONG and press the [ENT] key. Enter longitude and press the [ENT] key.
 - Press ▼ to select TIME and press the [ENT] key. Enter UTC time and press the [ENT] key.
- Press the [ENT] key to open the COM. TYPE menu.

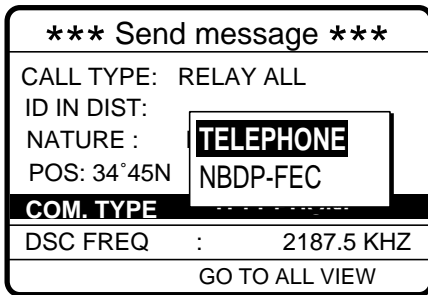

- Select TELEPHONE and press the [ENT] key.
- Press the [ENT] key to open the DSC FREQ menu.

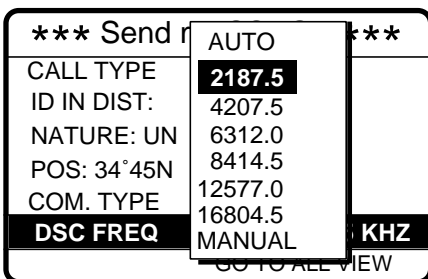

12. Select appropriate frequency and press the [ENT] key. The display now looks something like the one below.

*** Send message ***	
CALL TYPE:	RELAY ALL
ID IN DIST:	123456789
NATURE:	UNDESIGNATED
POS:	34°50N 135°45E AT 09:30
COM TYPE :	TELEPHONE
DSC FREQ :	2187.5 KHZ
GO TO ALL VIEW	

13. Press the [CALL] key to send the distress relay call (transmission time: about 43 sec.). The display shows the message "Distress relay all call in progress!".

Note: If a coast station acknowledges the distress alert call before the timer counts to zero, press the [CANCEL] key to cancel your call.

Distress relay all call in progress!	
SHIP IN DIST:	123456789
POS:	34°50N 135°45E AT 09:30
TELEPHONE	2182.0 KHZ
DSC FREQ :	2187.5 KHZ
TIME TO GO:	29S

14. After the call is sent the DSC standby screen automatically appears.

3.4 Receiving Distress Relay All Ships

When you receive a distress relay confirm that you are not near the ship in distress and continue monitoring distress and safety frequencies over the SSB radiotelephone.

1. The audio alarm sounds and the display looks like the one below when a distress relay all ships call is received.

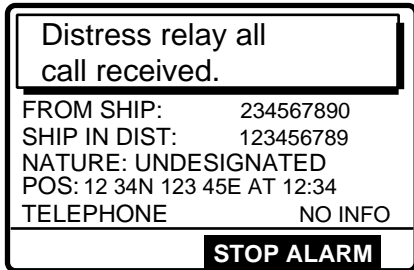

2. Press the [CANCEL] key to silence the alarm, and the display changes as below.

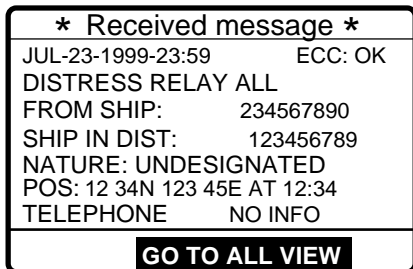

4. CALLING

This chapter provides the information necessary for general calling.

4.1 All Ships Call

When an urgent but not life endangering situation arises on your ship, for example, engine trouble, send an all ships call to request assistance.

After sending the message, you can communicate by voice over the radiotelephone. Do the following before beginning actual communications:

URGENCY priority: Say PAN three times followed by your call sign

SAFETY priority: Say SECURITE three times followed by your call sign.

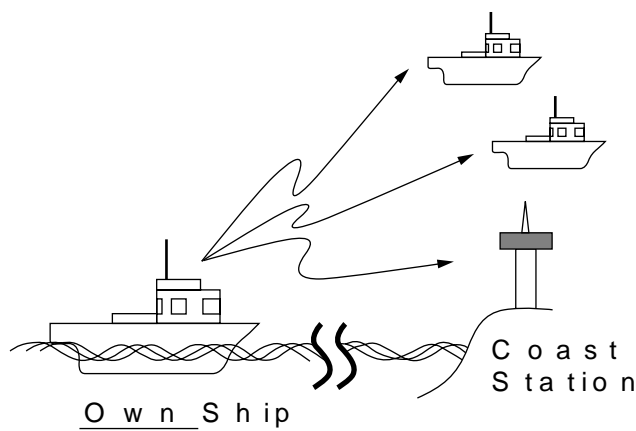

4.1.1 Sending all ships call

1. At the DSC standby screen, press the [CALL] key followed by the [ENT] key to display the CALL TYPE menu.

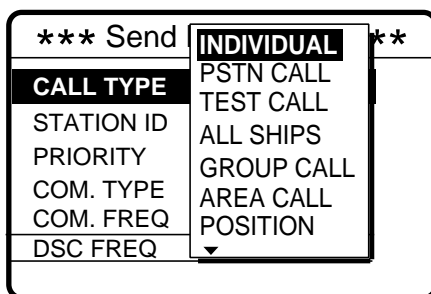

If this part of the menu appears, use ▲ to scroll the menu.

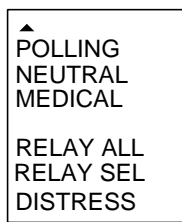

2. Use ▲ or ▼ to select ALL SHIPS and press the [ENT] key.

- Press the [ENT] key to display the PRIORITY menu.

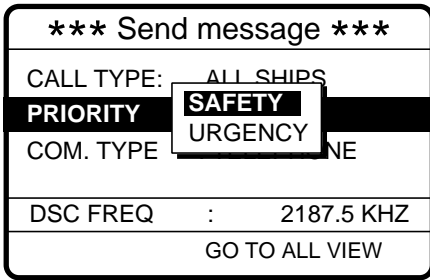

- Select SAFETY or URGENCY as appropriate and press the [ENT] key.
- Press the [ENT] key to open the COM. TYPE menu.

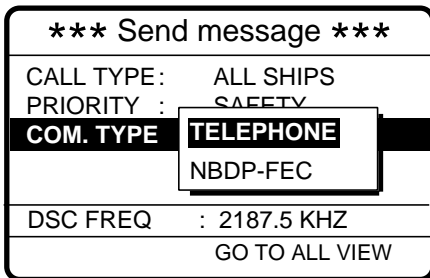

- Select communication type desired and press the [ENT] key.
- Press the [ENT] key to open the DSC FREQ menu.

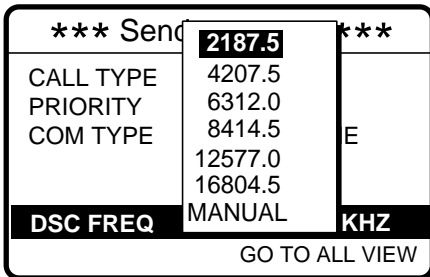

- Select frequency and press the [ENT] key.
- Press the [CALL] key to send the call (transmission time: 6-8 sec.). The display shows "All ships call in progress!" while the call is being sent.

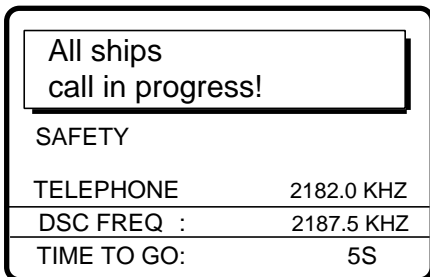

- The DSC standby screen automatically appears after the call is sent (timer counts down to zero).

4.1.2 Receiving all ships call

1. When an all ships call is received the audio alarm sounds and the display looks like something like the one shown below.

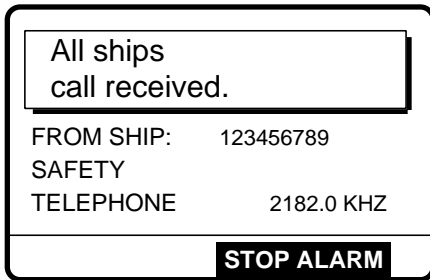

2. Press the [CANCEL] key to silence the alarm. The display shows partial contents of the all ships call as below.

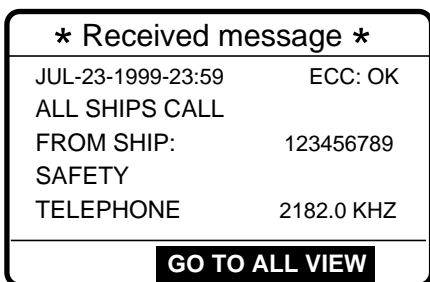

4.2 Individual Call

The individual call is for sending a message to a specific station. After sending an individual message, called ACK RQ transmission, wait to receive the acknowledge back (ACK BQ) signal from the receiving station. You should receive it within five minutes.

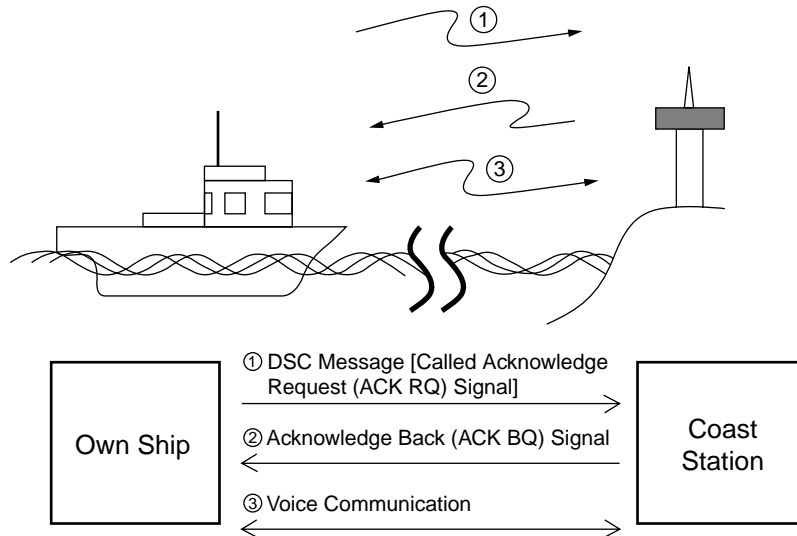

4.2.1 Sending individual call

1. At the DSC standby screen, press the [CALL] key followed by the [ENT] key to open the CALL TYPE menu.

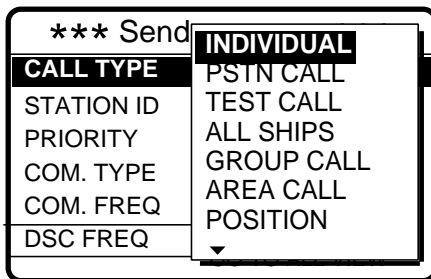

If this part of the menu appears use ▲ to scroll menu.

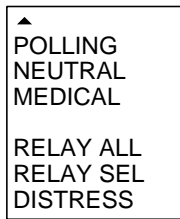

2. Use ▲ or ▼ to select INDIVIDUAL and press the [ENT] key.
3. Press the [ENT] key to open the STATION ID menu.

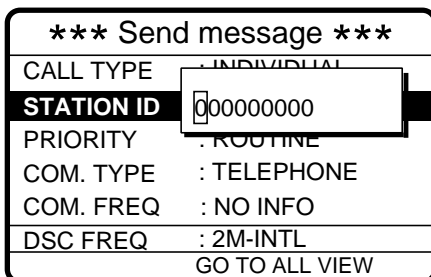

If you have registered some station IDs (see page 6-1), you can insert them into your message as follows:

1. Press the [FILE] key to show the following display.

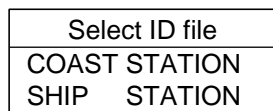

2. Select COAST STATION or SHIP STATION and press the [ENT] key.
3. Select ID to use Press ▶ to show ID number.
4. Press the [ENT] key to insert number.

4. Key in ID of station where to send the message and then press the [ENT] key.

- Press the [ENT] key to open the PRIORITY menu.

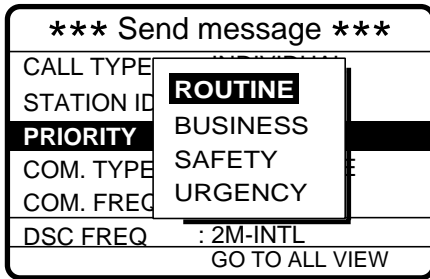

- Select appropriate priority (normally ROUTINE) and press the [ENT] key.
- Press the [ENT] key to open the COM. TYPE menu.

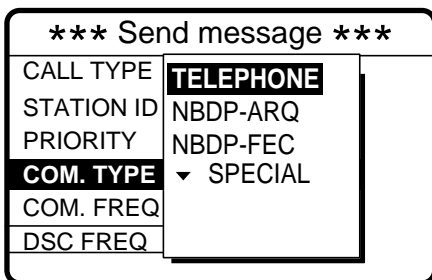

For Routine or Business Priority

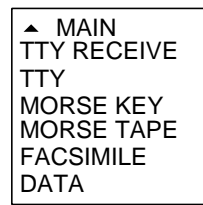

For Safety or Urgency Priority



Use ▲ or ▼ to scroll menu.

For DATA (Select DATA and press [ENT]).

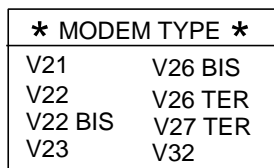

- Select communications type desired and press the [ENT] key.
- Press the [ENT] key to open the COM. FREQ menu.

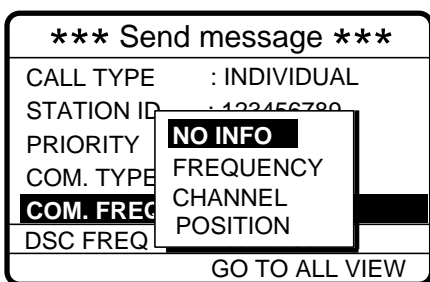

- Select item desired and press the [ENT] key. For FREQUENCY and CHANNEL see "How to Set Working Frequency" on the next page. NO INFO lets the receiving station set the working frequency; POSITION inputs yours position.

Continued on page 4-11.

How to set working frequency

When you send a call set the working frequency as below to communicate with the receiver of the message. The working frequency can be entered by Tx and Rx and frequencies as below or channel no. as in "Channel" on the next page.

Routine or ship's business priority

1. Press the [CALL] key, select the COM. FREQ field and press the [ENT] key.

*** Send message ***	
CALL TYPE:	INDIVIDUAL
STATION ID	001234567
PRIORITY	NO INFO
COM. TYPE	FREQUENCY
COM. FREQ	CHANNEL
DSC FREQ	POSITION
GO TO ALL VIEW	

2. Select NO INFO (frequency to be designated by sender), FREQUENCY, CHANNEL or POSITION (your position is input automatically) as appropriate.
3. For FREQUENCY or CHANNEL follow one of the sections below.

Frequency

1. Select FREQUENCY and press the [ENT] key.

TX:	0.0 KHZ
RX:	0.0 KHZ

2. Key in Tx frequency in five or six digits with the numeric keys and press the [ENT] key. For example, enter 12329.0 kHz.

TX:	12329.0 KHZ
RX:	0.0 KHZ

3. Enter Rx frequency and press the [ENT] key. The Tx frequency entered appears in the COM. FREQ field.

*** Send message ***	
CALL TYPE:	INDIVIDUAL
STATION ID:	123456789
PRIORITY	: ROUTINE
COM. TYPE	: TELEPHONE
COM. FREQ	TX:12329.0 KHZ
DSC FREQ	: 12M-INTL
GO TO ALL VIEW	

Channel

1. Select CHANNEL and press the [ENT] key.
2. Key in channel no. in four or five digits and press the [ENT] key. For example, enter CH 12034.

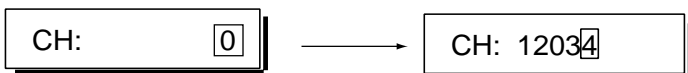

3. The channel entered appears in the COM. FREQ field.

*** Send message ***	
CALL TYPE:	INDIVIDUAL
STATION ID:	001234567
PRIORITY :	ROUTINE
COM. TYPE :	TELEPHONE
COM. FREQ :	CH 12034
DSC FREQ :	12M-INTL
GO TO ALL VIEW	

Safety or urgency priority

For safety or urgency priority the communication frequency cannot be selected; it is automatically set to the same band as set for the DSC frequency.

*** Send message ***	
CALL TYPE:	INDIVIDUAL
STATION ID:	123456789
PRIORITY :	SAFETY
COM. TYPE :	TELEPHONE
COM. FREQ :	2182.0 KHZ
DSC FREQ :	2187.5 KHZ
GO TO ALL VIEW	

<u>DSC Frequency (kHz)</u>	<u>Com. type: Telephone Com. Frequency</u>	<u>Com. type: NBDP-FEC Com. Frequency</u>
2187.5	2182.0	2174.5
4207.5	4125.0	4177.5
6312.0	6215.0	6268.0
8414.5	8291.0	8376.5
12577.0	12290.0	12520.0
16804.5	16420.0	16695.0

How to set DSC frequency

Routine or ship's business priority

1. Press the [CALL] key. (If PRIORITY is selected to other than ROUTINE or SHIP'S BUSINESS, press ▼ to select PRIORITY, press the [ENT] key, select ROUTINE or SHIP'S BUSINESS and then press the [ENT] key.)

*** Send message ***		OR	*** Send message ***	
CALL TYPE:	INDIVIDUAL		CALL TYPE:	INDIVIDUAL
STATION ID:	123456789		STATION ID:	123456789
PRIORITY :	ROUTINE		PRIORITY :	ROUTINE
COM. TYPE :	TELEPHONE		COM. TYPE :	TELEPHONE
COM. FREQ :	NO INFO		COM. FREQ :	NO INFO
DSC FREQ :	12M-INTL		DSC FREQ :	MANUAL
GO TO ALL VIEW			GO TO ALL VIEW	

If system setting "RT" is OFF, DSC FREQ. field displays MANUAL.

2. Select DSC FREQ and press the [ENT] key.

*** Send message ***	
CALL TYPE	2 MHZ
STATION ID	4 MHZ
PRIORITY	6 MHZ
COM. TYPE	8 MHZ
COM. FREQ	12 MHZ
DSC FREQ	▼
	TL
	VIEW

▲
16 MHZ
18 MHZ
22 MHZ
25 MHZ
OTHER
MANUAL

Use ▼ to scroll menu.

OTHER: Special, private channel
MANUAL: Manual tuning of radiotelephone

3. Select appropriate DSC frequency and press the [ENT] key. One of the menus shown on the next page appears depending on the DSC frequency selected here.

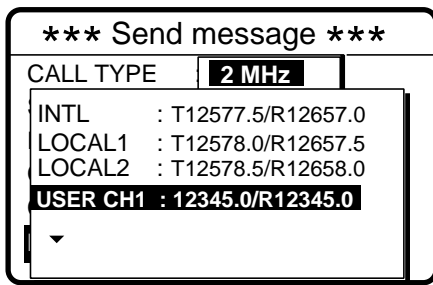

Use ▼ to scroll menu.

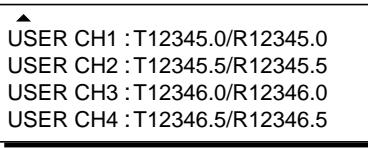

18MHz menu
 INTL : T18898.5/R19703.5
 LOCAL1 : T18899.0/R19704.0
 LOCAL2 : T18899.5/R19704.5

2MHz menu
 INTL : T 2189.5/R 2177.0

8MHz menu
 INTL : T 8415.0/R 8436.5

22MHz menu
 INTL : T22374.5/R22444.0
 LOCAL1 : T22375.0/R22444.5
 LOCAL2 : T22375.5/R22445.0

4MHz menu
 INTL : T 4208.0/R 4219.5
 LOCAL1 : T 4208.5/R 4220.0
 LOCAL2 : T 4209.0/R 4220.5

12MHz menu
 INTL : T12577.5/R12657.0
 LOCAL1 : T12578.0/R12657.5
 LOCAL2 : T12578.5/R12658.0

25MHz menu
 INTL : T25208.5/R26121.0
 LOCAL1 : T25209.0/R26121.5
 LOCAL2 : T25209.5/R26122.0

6MHz menu
 INTL : T 6312.5/R 6331.0
 LOCAL1 : T 6313.0/R 6331.5
 LOCAL2 : T 6313.5/R 6332.0

16MHz menu
 INTL : T16805.0/R16903.0
 LOCAL1 : T16805.5/R16903.5
 LOCAL2 : T16806.0/R16904.0

Other menu
 INTL : T 458.5/R 458.5

- Select channel with ▲ or ▼ and press the [ENT] key. The display shows the DSC frequency band selected.

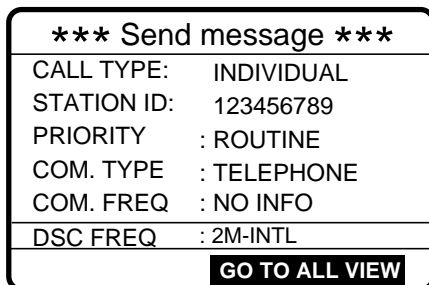

Safety or urgency priority

For safety or urgency priority the field COM. FREQ is automatically set to the same band as the DSC frequency.

1. Press the [CALL] key, select PRIORITY to SAFETY or URGENCY, and then select DSC FREQ and press the [ENT] key.

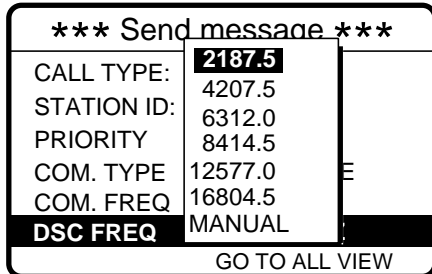

2. Select appropriate frequency with ▼ or ▲ and press the [ENT] key.

<u>DSC frequency</u>	<u>Com. type: Telephone Com. frequency</u>	<u>Com. type: NBDP-FEC Com. frequency</u>
2187.5 kHz	2182.0 kHz	2174.5 kHz
4207.5 kHz	4125.0 kHz	4177.5 kHz
6312.0 kHz	6215.0 kHz	6268.0 kHz
8414.5 kHz	8291.0 kHz	8376.5 kHz
12577.0 kHz	12290.0 kHz	12520.0 kHz
16804.5 kHz	16420.0 kHz	16695.0 kHz

11. Press the [ENT] key to open the DSC FREQ menu.

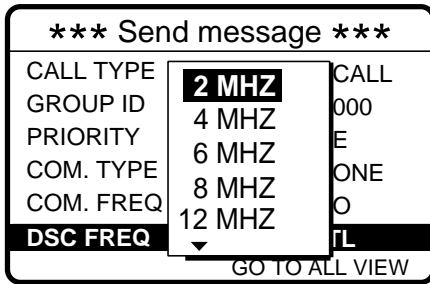

12. Select DSC frequency. The display should now look something like the one below.

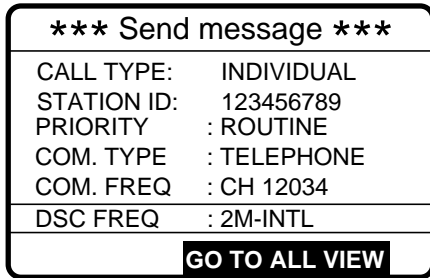

13. Press the [CALL] key to send the message (transmission time: 6-8 sec.). The display shows the message "Individual request call in progress!" while the message is being sent.

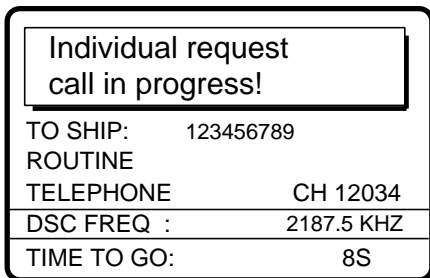

14. After the message is sent, the equipment waits for acknowledgement of the message, showing the display below.

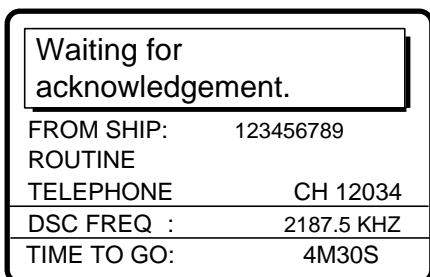

15. The timer starts counting down the maximum time to wait for acknowledgement, 3.5-4.5 minutes, randomly set. One of the following three messages appears. ("No response! Try calling again." appears after the timer counts down to zero. It means the station called did not respond.)

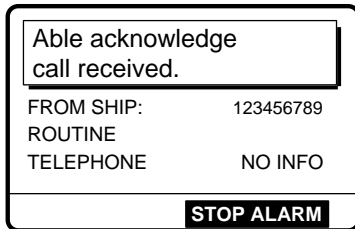

Able acknowledge call received

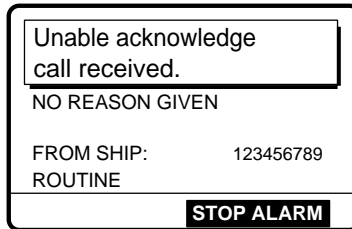

Unable acknowledge call received

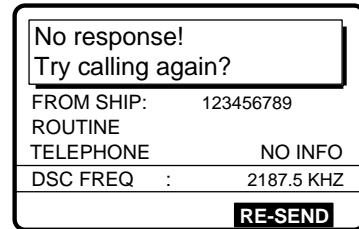

No response from station

16. Do one of the following depending on the message shown in step 15.

Able acknowledge call received

The audio alarm sounds; press the [CANCEL] key to silence it. The display changes as below. Press the [CANCEL] key to return to the DSC standby screen.

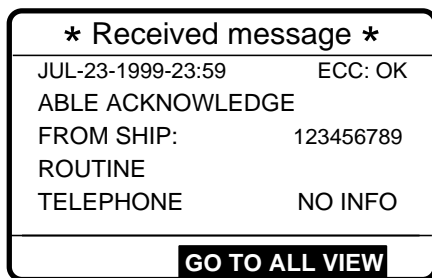

Unable acknowledge call received

The alarm sounds; press the [CANCEL] key to silence the alarm, and the display looks something like the one below. Send the call again later.

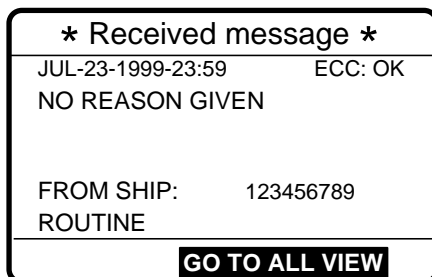

Reason for unable to acknowledge:
 NO REASON GIVEN
 CONGESTION AT SWITCHING CENTRE
 BUSY
 QUEUE INDICATION
 STATION BARRED
 NO OPERATOR AVAILABLE
 OPERATOR TEMPORARILY UNAVAILABLE
 EQUIPMENT DISABLED
 MODE NOT USABLE
 CHANNEL NOT USABLE

No response! Try calling again?

Press the [ENT] key (the display shown in step 12 appears) followed by the [CALL] key to re-send the call, or press the [CANCEL] key to return to the DSC standby screen.

4.2.2 Receiving individual call

Sending automatic acknowledge (ACK BQ) to sender

When own ship receives an individual call you may or may not be able to receive the call depending on the comply type setting as below. The relationship between comply type and automatic/manual acknowledge is as below.

Comply type, automatic acknowledge	ABLE	UNABLE
AUTO ACK	Can send acknowledge automatically	Cannot send automatic acknowledge
MANUAL ACK	Can send acknowledge manually	Cannot send manual acknowledge

1. When an individual call is received and the automatic acknowledge feature is active, the display shown below appears, indicating the auto acknowledge call (ACK BQ) call is being sent.

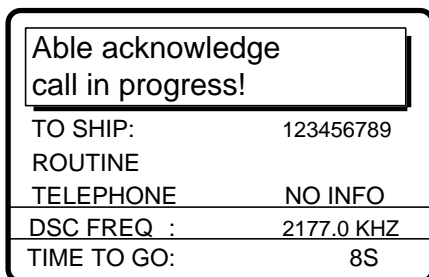

2. It takes about 6-8 sec. to transmit the call, after which the audio alarm sounds and the following message appears.

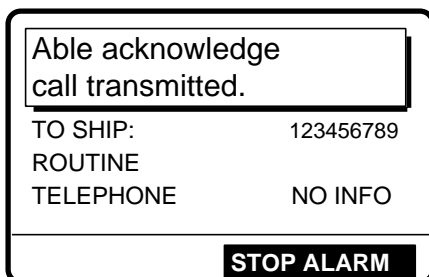

3. Press the [CANCEL] key to silence the alarm and the following display appears.



4. To re-send the message select RE-SEND and press the [ENT] key.

*** Send message ***	
CALL TYPE	: INDIVIDUAL
SHIP ID	: 123456789
PRIORITY	: ROUTINE
COM. TYPE	: TELEPHONE
COM. FREQ	: NO INFO
DSC FREQ	: 2M-INTL
GO TO ALL VIEW	

5. Press the [CALL] key to send the call.

Manually acknowledging individual call

1. When an individual call is received, the alarm sounds and the display looks like the one below.



2. Press the [CANCEL] key to silence the alarm, and the display changes as shown below.



3. Press ◀ at the display which shows GO TO ALL VIEW to select "ANSWER" and then press the [ENT] key.

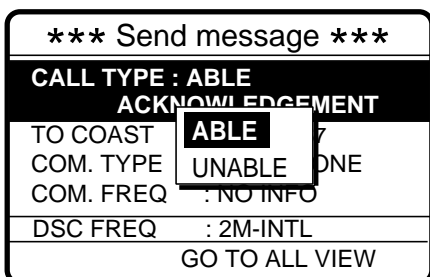

4. Select ABLE and press the [ENT] key. The display changes as below.

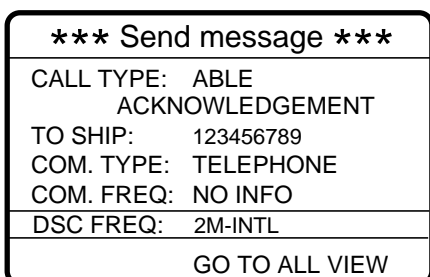

5. Press the [CALL] key to send the call, and the display changes as below.

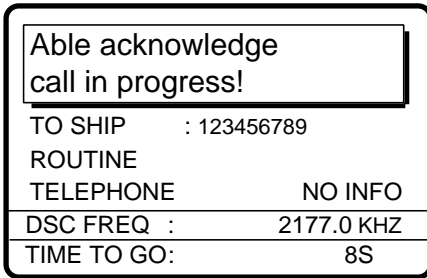

6. After the call is sent (transmission time: 6-8 sec.), press the [CANCEL] key to return to the DSC standby screen.

Manually acknowledging individual call with unable acknowledge

1. When an individual call is received the alarm sounds and the display shows the message "Individual request call received."



2. Press the [CANCEL] key to silence the alarm, and the display changes as below.



3. Press ◀ to select ANSWER and press the [ENT] key.
4. Press the [ENT] key to open the CALL TYPE menu.

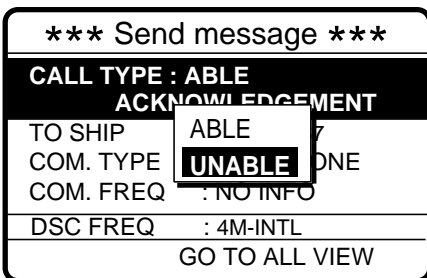

5. Select UNABLE and press the [ENT] key.

- Press the [ENT] key. The display then prompts you for the reason you are unable to acknowledge.

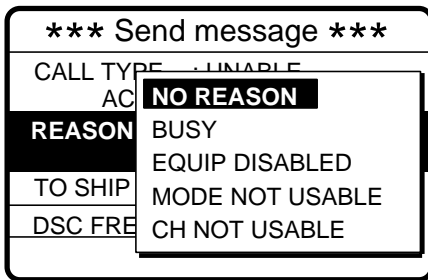

- Select suitable reason and press the [ENT] key.
- Press the [ENT] key to open the DSC FREQ menu. Select appropriate frequency and press the [ENT] key. The display changes as below.

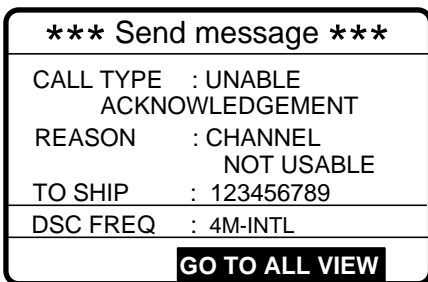

- Press the [CALL] key to send the call. The display shows "Unable acknowledge call in progress!" while the call is being sent.

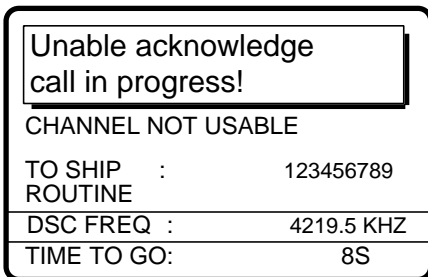

- The timer counts down the time remaining until the message is sent (transmission time: 6-8 sec.). The DSC standby screen automatically appears upon completion of transmission.

4.3 Group Call

A group call is for calling a specific group by entering its group ID.

4.3.1 Sending a group call

1. Press the [CALL] key at the DSC standby screen, and press the [ENT] key to open the CALL TYPE menu.

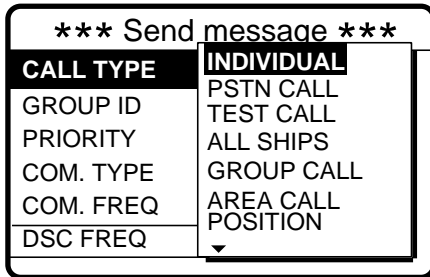

If this part of the menu appears use ▲ to scroll the menu.

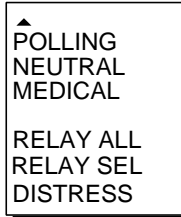

2. Use ▲ or ▼ to select GROUP CALL and press the [ENT] key.
3. Press the [ENT] key to open the GROUP ID menu.

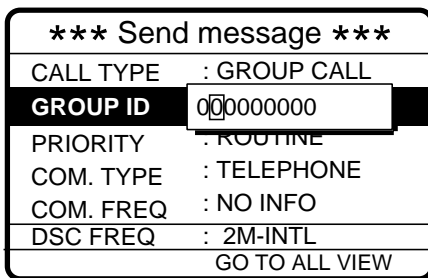

4. Key in group ID (nine digits) where to send the message and press the [ENT] key.
5. Press the [ENT] key to open the PRIORITY menu.

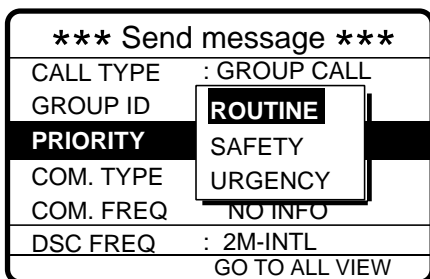

6. Select priority desired and press the [ENT] key.

7. Press the [ENT] key to open the COM. TYPE menu.

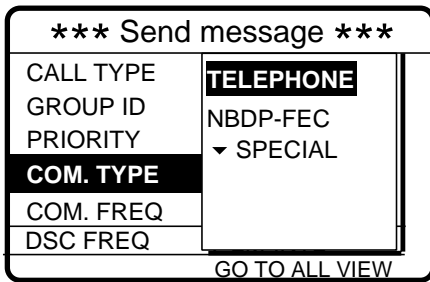

For Routine
Use ▼ to scroll menu.



For Safety or Urgency



8. Select communication type desired and press the [ENT] key.

9. Press the [ENT] key to open the COM. FREQ menu.

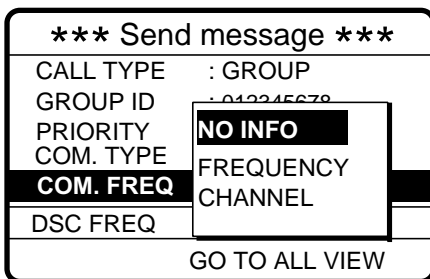

10. Select communication frequency desired and press the [ENT] key.

11. Press the [ENT] key to open the DSC FREQ menu.

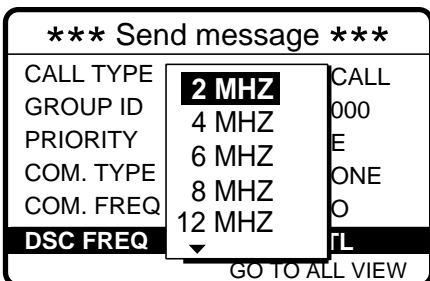

12. Select DSC frequency and press the [ENT] key.



13. Press the [CALL] key to send the group call (transmission time: 6-8 sec.). The display shows "Group call in progress" while the call is being sent.

Group call in progress!	
GROUP ID :	012345678
ROUTINE	
TELEPHONE	NO INFO
DSC FREQ :	2177.0 KHZ
TIME TO GO :	8S

14. The DSC standby screen automatically appears after the message is sent.

4.3.2 Receiving a group call

Group ID must be registered in order to receive a group call. See note on page 6-5.

1. The audio alarm sounds and the display shows "Group call received" when a group call is received.

Group call received.	
FROM SHIP:	123456789
ROUTINE	
TELEPHONE	NO INFO
STOP ALARM	

2. Press the [CANCEL] key to silence the alarm, and the display changes as below.

* Received message *	
JUL-23-1999-23:59	ECC: OK
GROUP CALL	
FROM SHIP :	123456789
ROUTINE	
TELEPHONE	NO INFO
GO TO ALL VIEW	

4.4 Geographic Area Call

The geographic area call sends a call to all ships within a specific area you designated in your geographic area call message. In the figure below, for example, the call will be sent to all ships within 10°N and 5°W of 34°N, 135°W.

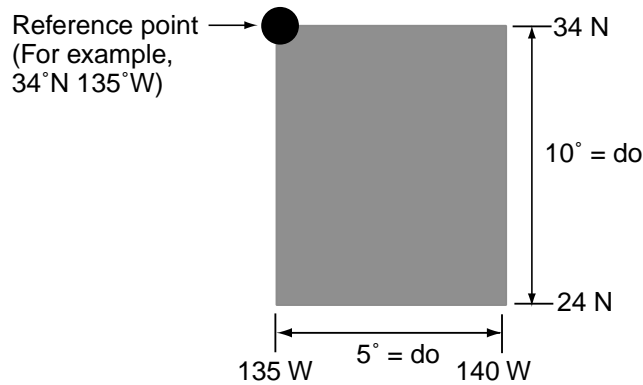

4.4.1 Sending a geographic area call

1. Press the [CALL] key at the DSC standby screen, and press the [ENT] key to open the CALL TYPE menu.

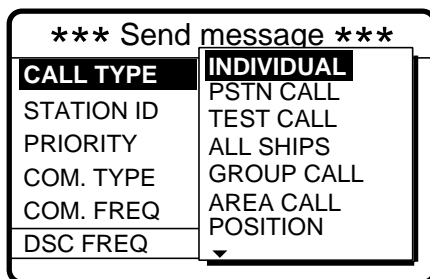

If this part of the menu appears use ▲ to scroll.

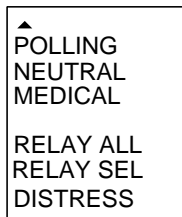

2. Use ▲ or ▼ to select AREA CALL and press the [ENT] key.
3. Press the [ENT] key to open the AREA menu.

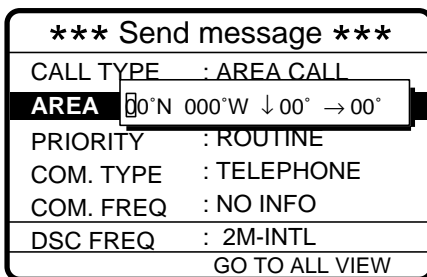

4. Enter latitude, longitude and length and width of area (in degrees) and press the [ENT] key.

- Press the [ENT] key to open the PRIORITY menu.

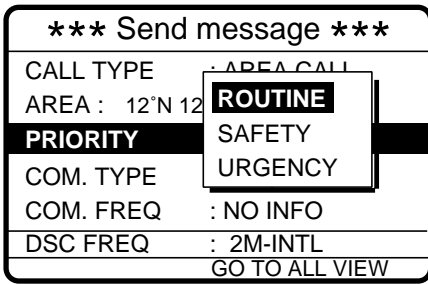

- Select priority desired and press the [ENT] key.
- Press the [ENT] key to open the COM. TYPE menu.

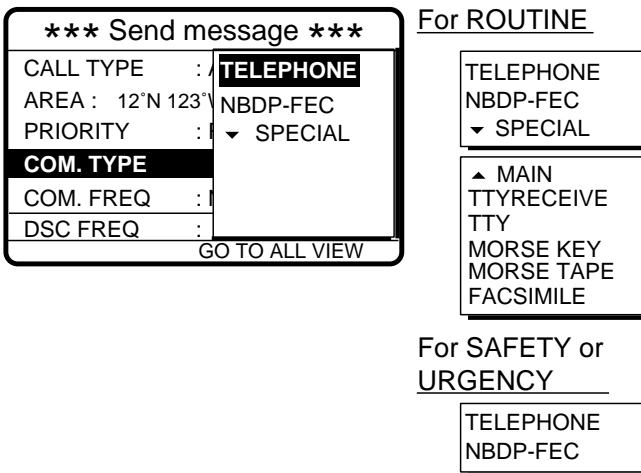

- Select communication type desired and press the [ENT] key.
- Press the [ENT] key to open the COM. FREQ menu.

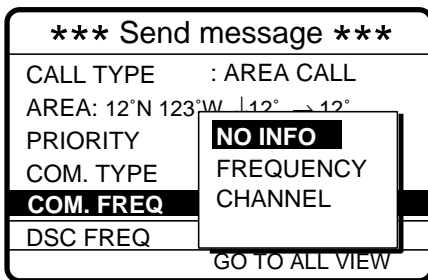

- Select communication frequency desired and press the [ENT] key.
- Press the [ENT] key to open the DSC FREQ menu.

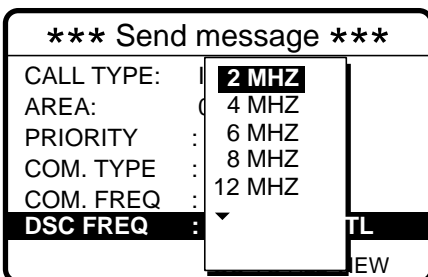

12. Select DSC frequency and press the [ENT] key. Your display should now look something like one below.

*** Send message ***	
CALL TYPE	: AREA CALL
AREA	: 12°N 123°W ↓12° → 12°
PRIORITY	: ROUTINE
COM. TYPE	: TELEPHONE
COM. FREQ	: 2164.0 KHZ
DSC FREQ	: 2M-INTL
GO TO ALL VIEW	

13. Press the [CALL] key to send the geographic area call (transmission time: 6-8 sec.). The display shows "Geographical area call in progress!" while the call is being sent.

Geographical area call in progress!	
AREA:	12°N 123°W ↓12° → 12°
ROUTINE	
TELEPHONE	2164.0 KHZ
DSC FREQ	: 2177.0 KHZ
TIME TO GO	: 8S

14. After the call is sent (timer counts down to zero), the DSC standby screen automatically appears.

4.4.2 Receiving a geographic area call

1. The alarm sounds and the display shows "Geographic area call received" when a geographic area call is received.



2. The audio alarm sounds; press the [CANCEL] key to silence the alarm. The display changes as below.

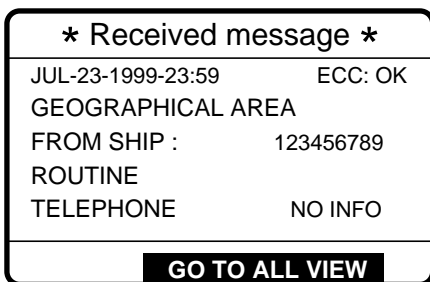

3. Press the [CANCEL] key at any time to return to the DSC standby screen.

4.5 Neutral Craft Call

This type of call informs all ships that your ship is not a participant in armed conflict.

4.5.1 Sending a neutral craft call

1. Press the [CALL] key followed by the [ENT] key to display the CALL TYPE menu.

*** Send r	▲	POLLING
CALL TYPE		NEUTRAL
STATION ID		MEDICAL
PRIORITY		RELAY ALL
		RELAY SEL
DSC FREQ		DISTRESS

If this part of the menu appears use ▼ to scroll the menu.

INDIVIDUAL
PSTN CALL
TEST CALL
ALL SHIPS
GROUP CALL
AREA CALL
POSITION
▼

2. Use ▲ or ▼ to select NEUTRAL and press the [ENT] key.
3. Press the [ENT] key to open the PRIORITY menu.

*** Send message ***	
CALL TYPE	: NEUTRAL
PRIORITY	SAFETY
	URGENCY
COM. TYPE	: TELEPHONE
DSC FREQ	: 2187.5 KHZ
GO TO ALL VIEW	

4. Select appropriate priority and press the [ENT] key.
5. Press the [ENT] key to open the DSC FREQ menu.

Note: COM. TYPE is fixed at TELEPHONE.

*** Send	2187.5	***
CALL TYPE	4207.5	
	6312.0	
	8414.5	
PRIORITY	12577.0	
COM. TYPE	16804.5	
DSC FREQ	MANUAL	KHZ
GO TO ALL VIEW		

6. Select appropriate frequency and press the [ENT] key.

- The display changes as below. You are now ready to send the neutral craft call.

*** Send message ***	
CALL TYPE	: NEUTRAL CRAFT
PRIORITY	: SAFETY
COM. TYPE	: TELEPHONE
DSC FREQ	: 2187.5 KHZ
GO TO ALL VIEW	

- Press the [CALL] key to send the neutral craft call (transmission time: 6-8 sec.).

Neutral craft call in progress!	
SAFETY	
TELEPHONE	2182.0 KHZ
DSC FREQ :	2187.5 KHZ
TIME TO GO:	8S

- After the call is sent (timer counts down to zero), the DSC standby screen automatically appears.

4.5.2 Receiving a neutral craft call

- When a neutral craft call is received the alarm sounds and the display changes as below.

Neutral craft call received.	
FROM SHIP:	123456789
SAFETY	
TELEPHONE	2182.0 KHZ
STOP ALARM	

- The audio alarm sounds; press the [CANCEL] key to silence the alarm. The display changes as below.

* Received message *	
JUL-23-1999-23:59	ECC: OK
NEUTRAL CRAFT	
FROM SHIP:	123456789
SAFETY	
TELEPHONE	2182.0 KHZ
GO TO ALL VIEW	

4.6 Medical Transport Call

The medical transport call informs all ships, by using the "urgent" category, that own ship carries medical supplies.

4.6.1 Sending a medical transport call

1. Press the [CALL] key followed by the [ENT] key to open the CALL TYPE menu.

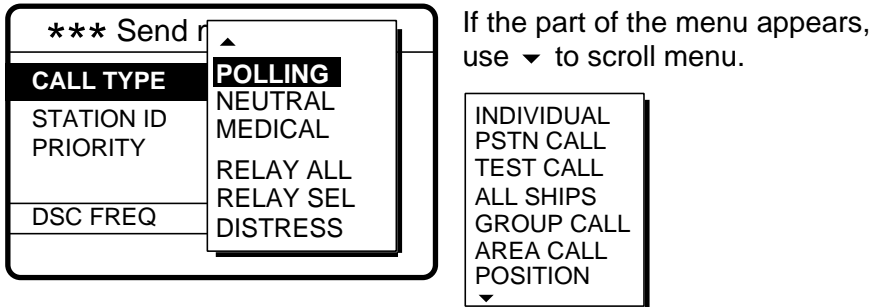

If the part of the menu appears, use ▼ to scroll menu.

2. Use ▲ or ▼ to select MEDICAL and press the [ENT] key.

Note: PRIORITY and COM. TYPE are automatically selected to URGENCY and TELEPHONE, respectively.

3. Press the [ENT] key to open the DSC FREQ menu.

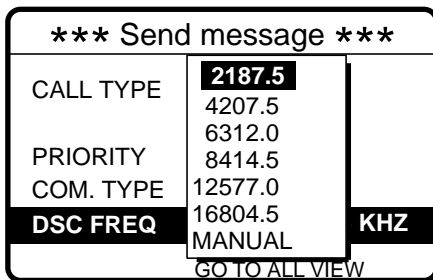

4. Select appropriate frequency and press the [ENT] key. The display changes as below.

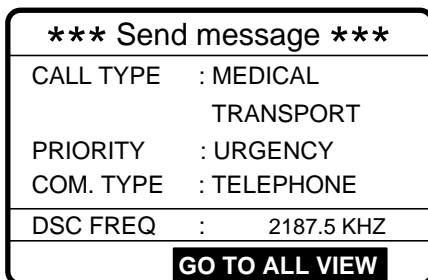

5. Press the [CALL] key to send the call (transmission time: 6-8 sec.). The display shows "Medical transport call in progress!" while the message is being sent.

Medical transport call in progress!	
URGENCY	
TELEPHONE	2182.0 KHZ
DSC FREQ :	2187.5 KHZ
TIME TO GO :	8S

6. After the message is sent (timer counts down to zero) the DSC standby screen automatically appears.

4.6.2 Receiving a medical transport call

1. When a medical transport call is received, the alarm sounds and the display looks as below.

Medical transport call received.	
FROM SHIP:	123456789
URGENCY	
TELEPHONE	2182.0 KHZ
STOP ALARM	

2. Press the [CANCEL] key to silence the alarm. The display changes as below.

* Received message *	
JUL-23-1999-23:59	ECC: OK
MEDICAL TRANSPORT	
FROM SHIP:	123456789
URGENCY	
TELEPHONE	2182.0 KHZ
GO TO ALL VIEW	

4.7 Polling Call

Polling means confirming if own station is within communicating range with other station. This function only provides affirmative or negative response; it does not provide position information. Note that simultaneous polling to more than one station is not possible.

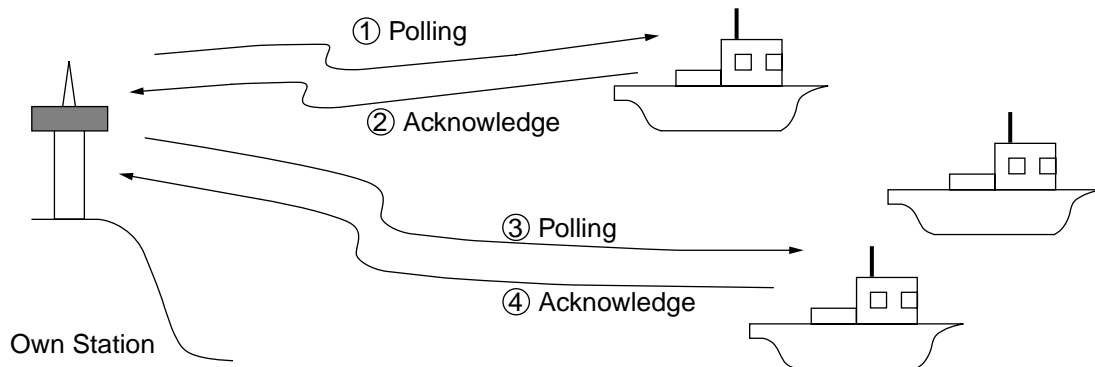

4.7.1 Sending a polling call

1. Press the [CALL] key followed by the [ENT] key to open the CALL TYPE menu.

*** Send message ***	
CALL TYPE	POLLING
STATION ID	NEUTRAL
PRIORITY	MEDICAL
DSC FREQ	RELAY ALL
	RELAY SEL
	DISTRESS

If the part of the menu appears, use ▼ to scroll menu.

INDIVIDUAL
PSTN CALL
TEST CALL
ALL SHIPS
GROUP CALL
AREA CALL
POSITION

2. Use ▲ or ▼ to select POLLING and press the [ENT] key.
3. Press the [ENT] key to open the STATION ID menu.

*** Send message ***	
CALL TYPE	: POLLING
STATION ID	<input type="text" value="00000000"/>
PRIORITY	: ROUTINE
DSC FREQ	: 2M-INTL
GO TO ALL VIEW	

4. Key in ID of station where to send call and press the [ENT] key.

- Press the [ENT] key to open the PRIORITY menu.

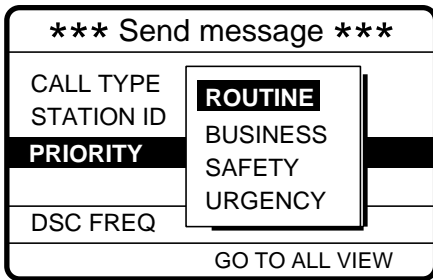

- Select priority desired (usually ROUTINE) and press the [ENT] key.
- Press the [ENT] key to open the DSC FREQ menu.

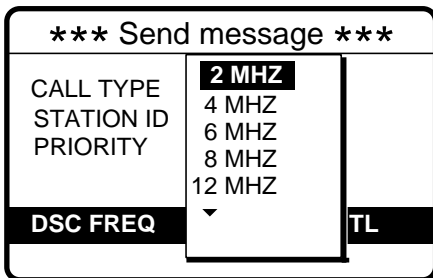

- Select appropriate frequency and press the [ENT] key. The display changes as below.

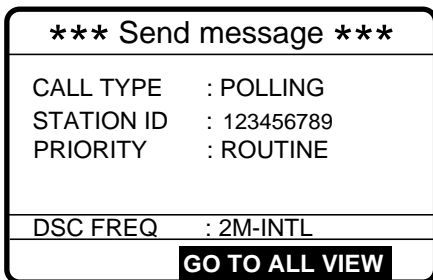

- Press the [CALL] key to send the call (transmission time: 6-8 sec.), and the display changes as below.

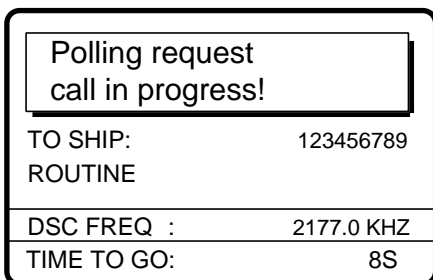

10. After the call is sent (timer counts down to zero) the following display appears.

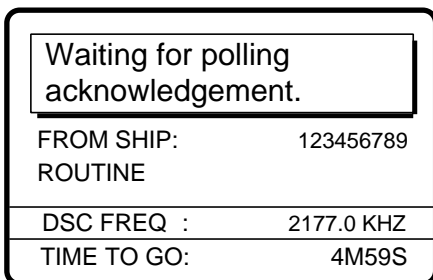

11. The timer counts down the time remaining to wait for acknowledgment of the call. One of the following displays appears. (“No response! Try calling again?” appears when there is no response from receiving station; timer counts down to zero.)

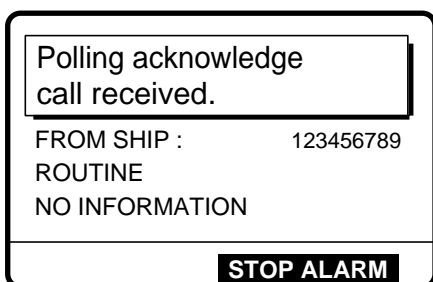

Polling acknowledge call received

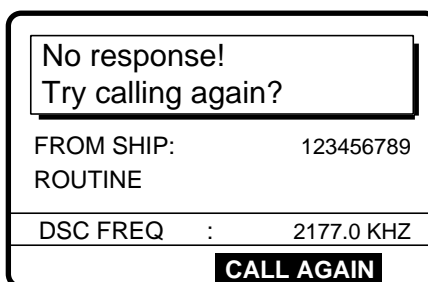

No response

12. Do one of the following depending on the message shown in step 11.

Polling acknowledge call received

The audio alarm sounds; press the [CANCEL] key to silence the alarm, and the display changes as below.

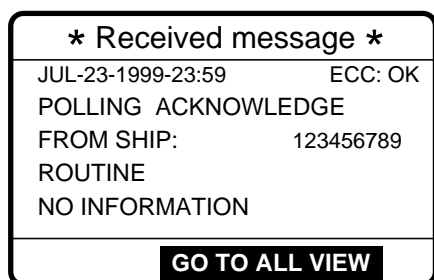

No response! Try calling again?

Press the [ENT] key (the display shown in step 8 appears), followed by the [CALL] key to re-send the call, or press the [CANCEL] key to return to the DSC standby screen.

4.7.2 Receiving a polling call

Automatic reply

1. The display changes as follows and the audio alarm sounds when a polling request call is received and the status of the [5/ACK] key is AUTO ACK.

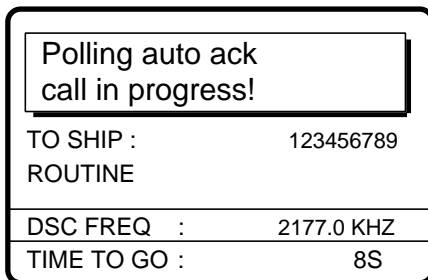

2. After the call is transmitted the audio alarm sounds; press the [CANCEL] or [ENT] key to silence the alarm.

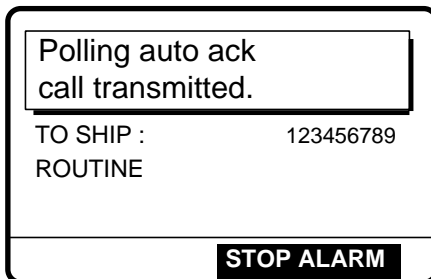

3. The alarm sounds; press the [CANCEL] key to silence the alarm. The display changes as below.

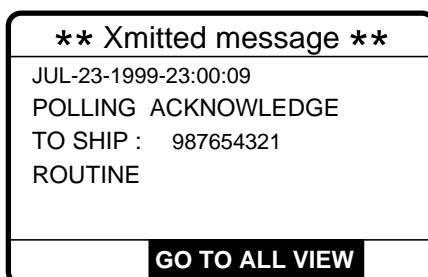

4. Press the [CANCEL] key to return to the DSC standby screen.

Manual reply

1. It takes seven seconds to complete transmission of acknowledgement. Then the display changes as below.



2. The alarm sounds; press the [CANCEL] to key to silence the alarm. The display changes as below.



3. Press < to select ANSWER and press the [ENT] key. The display changes as below.

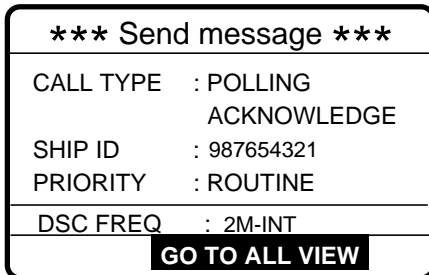

4. Press the [CALL] key to send the call. The display changes as below.

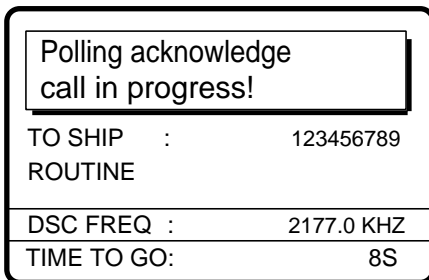

After the call is sent the DSC standby screen appears.

4.8 Position Call

There are two types of position calls: you send your position to other stations and your ship requests position of another ship.

Sending own ship's position to other stations

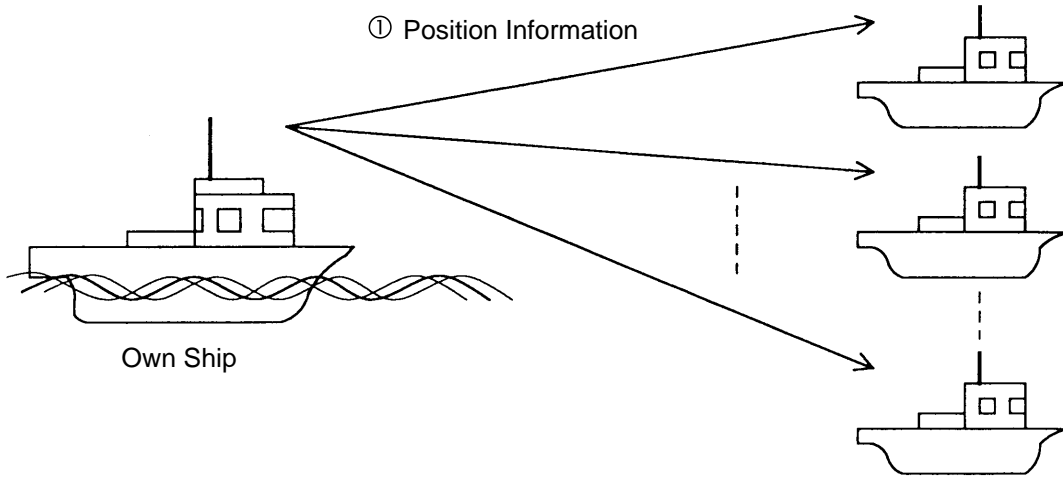

Finding position of other station

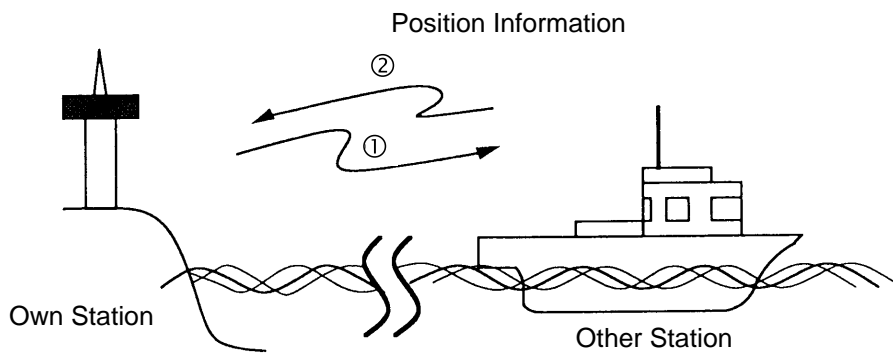

4.8.1 Position call: requesting other ship's position

1. Press the [CALL] key, and press the [ENT] key to open the CALL TYPE menu.

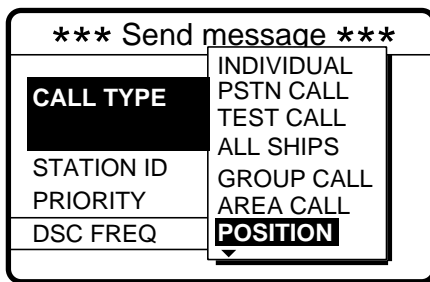

If this part of menu appears, use ▲ to scroll menu.

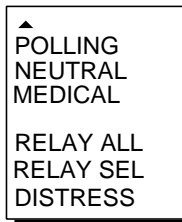

2. Use ▲ or ▼ to select POSITION and press the [ENT] key.
3. Press the [ENT] key to open the STATION ID menu.

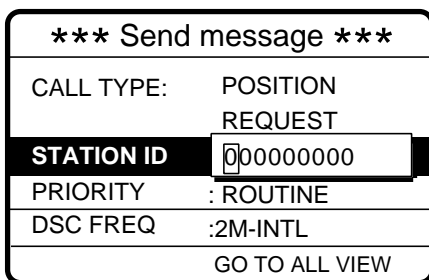

4. Key in ID of station (nine digits) of which you want their position and press the [ENT] key.
5. Press the [ENT] key to open the PRIORITY menu.

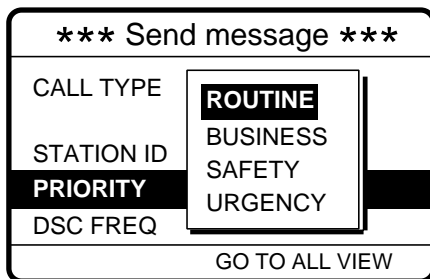

6. Select priority desired (usually ROUTINE) and press the [ENT] key.
7. Press the [ENT] key to open the DSC FREQ menu.

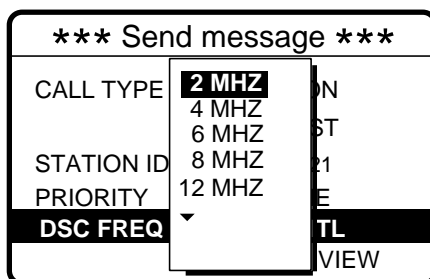

8. Select appropriate frequency and press the [ENT] key.

9. The display now looks something like the following.

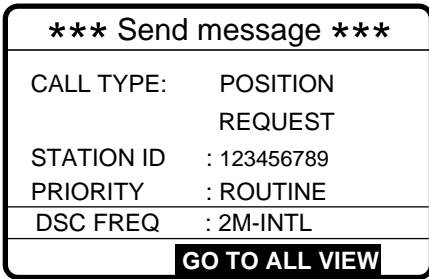

10. Press the [CALL] key to send the call (transmission time: 6-8 sec.). The following display appears.

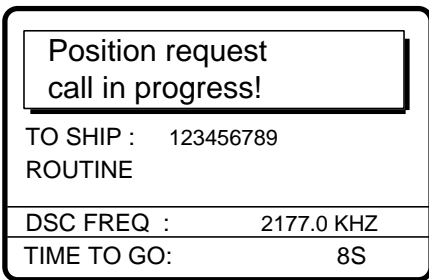

11. After the call has been sent (the timer counts down to zero) the following display appears.

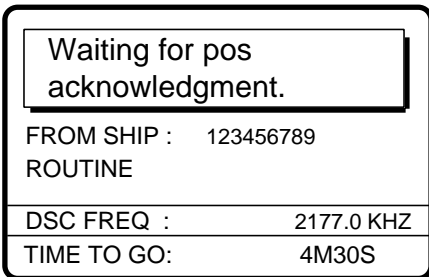

12. One of the following messages appears. (“No response! Try calling again?” appears after the time has counted down to zero, meaning there is no response from the receiving station.)



Position acknowledge call received

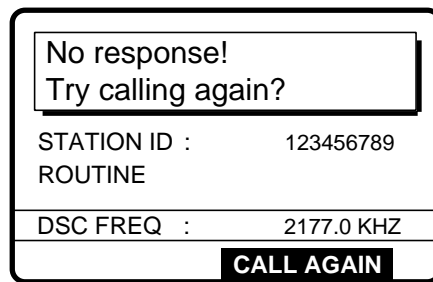

No response

13. Do one of the following depending on the message displayed at step 12.

Acknowledge call received

The audio alarm sounds; press the [CANCEL] or [ENT] key to silence the alarm. The display looks as below.

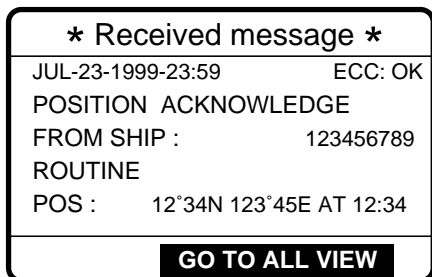

No response! Try calling again?

Press the [ENT] key (the display shown in step 9 appears) followed by the [CALL] key to re-send the call, or press the [CANCEL] key to return to the DSC standby screen.

4.8.2 Position call: other ship requests your position

Automatic reply

1. When another ship requests your position and the [5/ACK] key is set for automatic acknowledge the display changes as below.

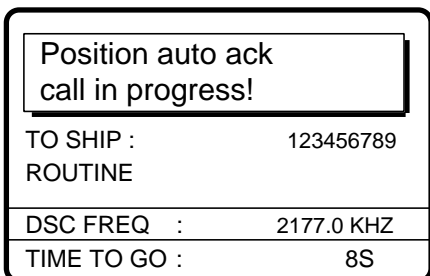

2. After the call is sent (transmission time: 6-8 sec.) the display below appears.

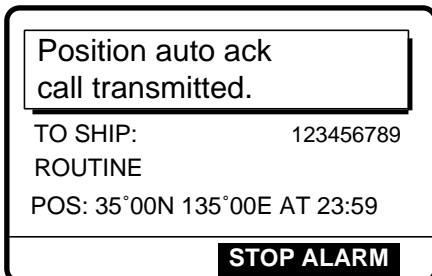

3. Press the [CANCEL] key to silence the alarm, and the display changes as below.

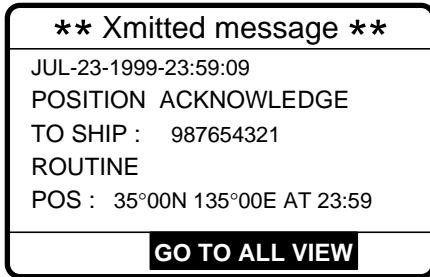

4. Press the [CANCEL] key to return to the DSC standby screen.

Manual reply

1. When another ship requests your position and the [5/ACK] key is set for manual acknowledge the display changes as below.



2. The audio alarm sounds; press the [CANCEL] key to silence the alarm. The display changes as below.



3. Press < to select ANSWER and press the [ENT] key. Your display should now look something like the one below.

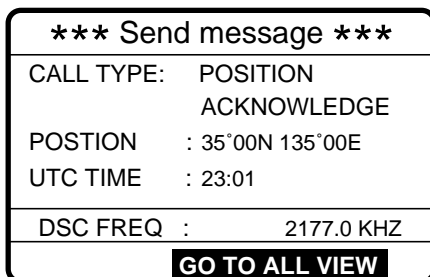

4. Press the [CALL] to send the call (transmission time: 6-8 sec.). The display changes as below.

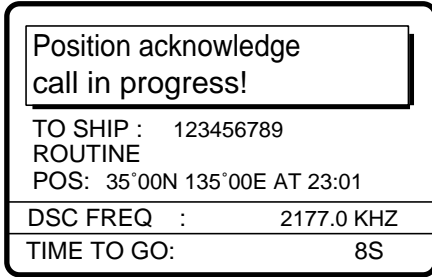

5. The DSC standby screen automatically appears after the call is sent.

4.9 PSTN Call

The PSTN call allows the making and receiving of telephone calls over public switched telephone networks.

4.9.1 Sending PSTN call, receiving acknowledge back (ACK BQ)

1. Press the [CALL] key followed by the [ENT] key to open the CALL TYPE menu.

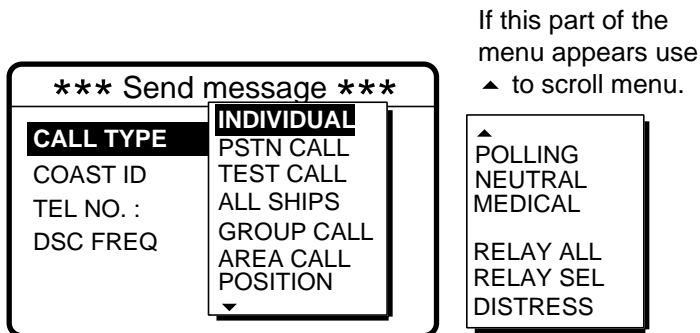

2. Select PSTN CALL and press the [ENT] key.
3. Press the [ENT] key to open the COAST ID menu.

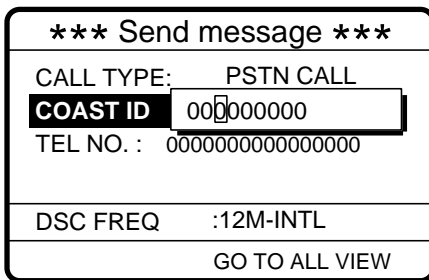

4. Key in ID of coast station (nine digits) to where to send the call and press the [ENT] key.
5. Press the [ENT] key to open the TEL NO menu.

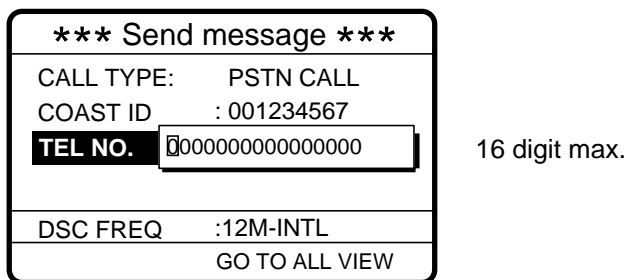

6. Enter telephone no. and press the [ENT] key.
7. Press the [ENT] key to open the DSC FREQ menu.

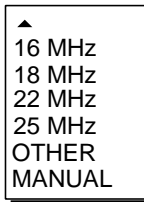
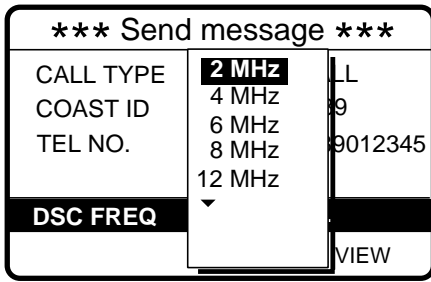

Use ▼ to scroll menu.

OTHER: Special, private channel
 MANUAL: Manual tuning of radiotelephone

8. Select DSC frequency and press the [ENT] key. The display changes as below.

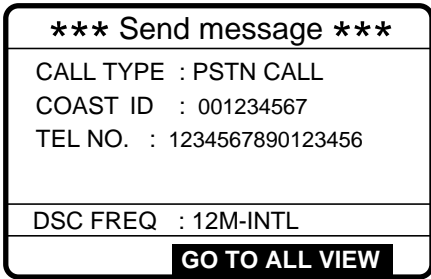

9. Press the [CALL] key to send the PSTN call (transmission time: 6-8 sec.). The display shows the following message.

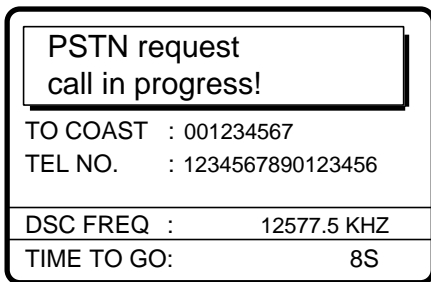

10. One of the following three displays appears. ("No response. Try calling again." appears if there is no response from the receiving station - the timer counts down to zero.)

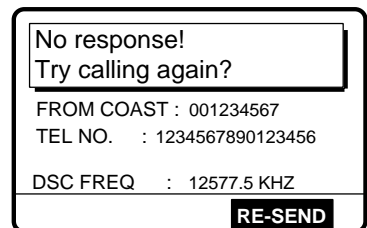
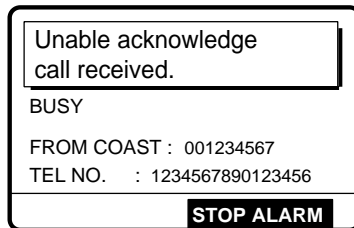
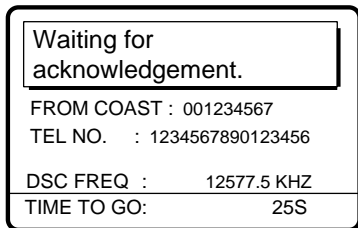

11. Do one of the following depending on the message shown at step 10.

Waiting for acknowledgement

1) The call is sent (transmission time: 6-8 sec.), showing the display below.

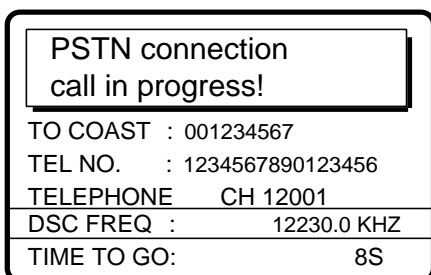

2) After the call is sent (timer counts down to zero) one of the following message appears.

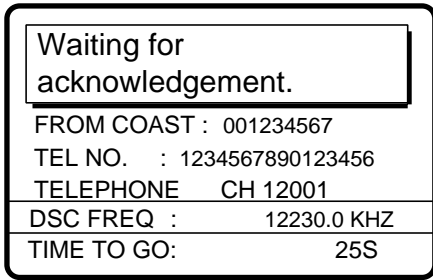

Waiting for acknowledgement

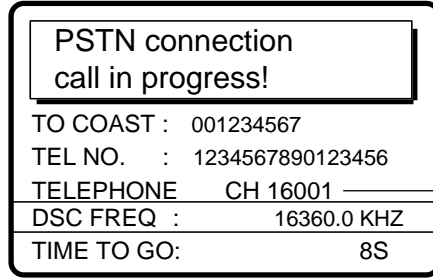

Request for new Tx assignment

3) One of the follow displays appears.

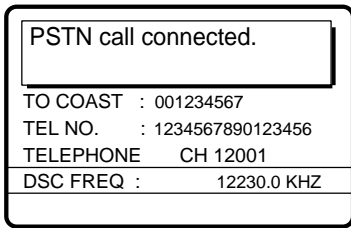

PSTN call connected

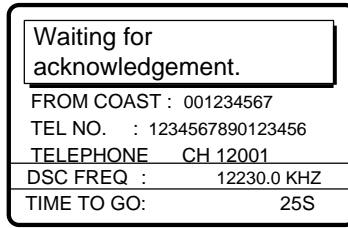

Waiting for acknowledgement

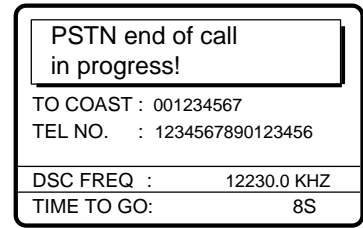

PSTN end of call

4) Follow the instructions below depending on the message shown in 3) above.

PSTN call connected: Your phone rings; pick up the handset and communicate with called party.

Waiting for acknowledgement: If the call is acknowledged the message “PSTN call connected.” appears. Follow “PSTN call connected” above.

PSTN end of call in progress: This means channel could not be used. After the timer counts down to zero repeat this procedure to re-send the call.

Unable acknowledge

1) The audio alarm sounds; press the [CANCEL] or [ENT] key to silence the alarm. The display shown at left in the figure below appears. Use the [ENT] key, ▲ and ▼ to view the reason for unable to acknowledge.

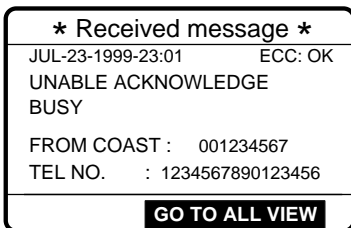

2) Press the [CANCEL] key to return to the DSC standby screen.

No response! Try calling again?

Press the [ENT] key (the display shown in step 7 appears) followed by the [CALL] key to re-send the message, or press the [CANCEL] key to return to the DSC standby screen.

4.9.2 Sending PSTN call, receiving acknowledge back (QUEUE indication), ring back

1. Press the [CALL] key followed by the [ENT] key to open the CALL TYPE menu.

If this part of the menu appears use ▲ to scroll menu.

*** Send message ***	
CALL TYPE	INDIVIDUAL
COAST ID	PSTN CALL
TEL NO. :	TEST CALL
DSC FREQ	ALL SHIPS
	GROUP CALL
	AREA CALL
	POSITION
	▼

▲
POLLING
NEUTRAL
MEDICAL
RELAY ALL
RELAY SEL
DISTRESS

2. Select PSTN CALL and press the [ENT] key.
3. Press the [ENT] key to open the COAST ID menu.

*** Send message ***	
CALL TYPE:	PSTN CALL
COAST ID	00000000
TEL NO. :	0000000000000000
DSC FREQ	:12M-INTL
GO TO ALL VIEW	

4. Key in ID of coast station (nine digits) to where to send the call and press the [ENT] key.
5. Press the [ENT] key to open the TEL NO. menu.

*** Send message ***	
CALL TYPE:	PSTN CALL
COAST ID	: 001234567
TEL NO.	0000000000000000
DSC FREQ	:12M-INTL
GO TO ALL VIEW	

16 digit max.

6. Enter telephone no. and press the [ENT] key.
7. Press the [ENT] key to open the DSC FREQ menu.

*** Send message ***		
CALL TYPE	2 MHz	LL
COAST ID	4 MHz	9
TEL NO.	6 MHz	9012345
	8 MHz	
	12 MHz	
DSC FREQ	▼	
		VIEW

▲
16 MHz
18 MHz
22 MHz
25 MHz
OTHER
MANUAL

Use ▼ to scroll menu.

OTHER: Special, private channel
MANUAL: Manual tuning of radiotelephone

8. Select DSC frequency and press the [ENT] key. The display changes as below.

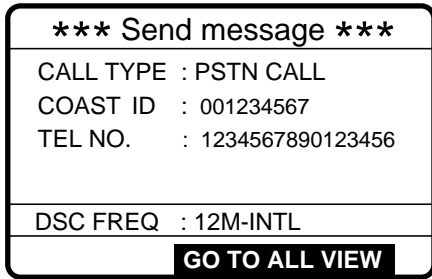

9. Press the [CALL] key to send the PSTN call (transmission time: 6-8 sec.). The display shows the following message.

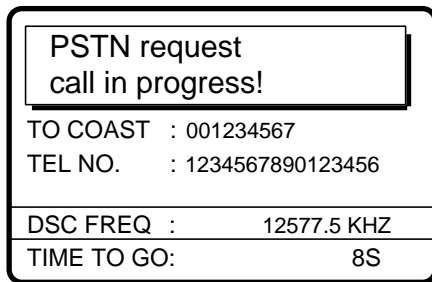

10. After the call is sent one of the following messages appears.

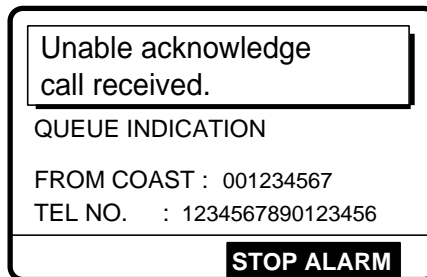
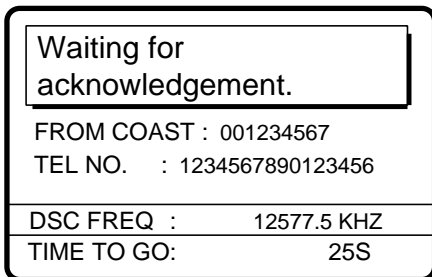

11. Do one of the following depending on the message shown at step 10.

Waiting for acknowledge

1) After the timer counts down to zero the following message appears.

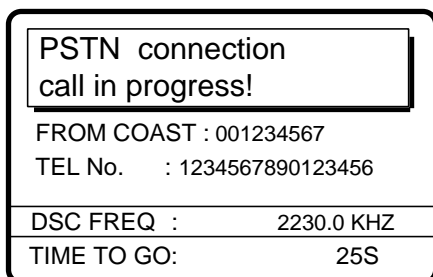

2) After the connection call is sent the following message appears.

Waiting for acknowledgement.	
FROM COAST :	001234567
TEL NO. :	1234567890123456
TELEPHONE	CH 12001
DSC FREQ :	12230.0 KHZ
TIME TO GO:	25S

Waiting for acknowledgement

3) After the timer counts down to zero one of the following messages appears.

PSTN call connected.	
TO COAST :	001234567
TEL NO. :	1234567890123456
TELEPHONE	CH 12001
DSC FREQ :	12230.0 KHZ

PSTN call connected

PSTN connection call in progress!	
FROM COAST :	001234567
TEL NO. :	1234567890123456
DSC FREQ :	12230.0 KHZ
TIME TO GO:	25S

PSTN connection call in progress

PSTN end of call in progress!	
TO COAST :	001234567
TEL NO. :	1234567890123456
TELEPHONE	CH 12001
DSC FREQ :	12230.0 KHZ
TIME TO GO:	8S

PSTN end of call

PSTN call connected: Your phone rings; pick up the handset and communication with receiving station.

PSTN connection call in progress!: This means coast station has switched DSC frequency. (If the channel cannot be used the message “PSTN end of call in progress!” appears. In this case, start this procedure again.) If the channel assigned is OK the message “Waiting for acknowledgment.” appears.

PSTN end of call in progress!: The channel could not be used. Press the [CANCEL] key to return to the DSC standby screen. Repeat this procedure to send the call again.

Unable to acknowledge call received

1) The alarm sounds; press the [CANCEL] or [ENT] key to silence the alarm. The display changes as below, waiting for the ring back call.

Waiting for ring-back call.	
FROM COAST :	001234567
TEL NO. :	1234567890123456
DSC FREQ :	12577.5 KHZ
TIME TO GO:	15M00S

- 2) One of the following displays appears. (For “No response. Try calling again?”, press the [ENT] key to re-send the call, or press the [CANCEL] key to cancel the call and return to the DSC standby screen.)

Able acknowledge call in progress!	
TO COAST :	001234567
TEL NO. :	1234567890123456
TELEPHONE	CH121001
DSC FREQ :	12577.5 KHZ
TIME TO GO:	8S

No response! Try calling again.	
FROM COAST :	001234567
TEL NO. :	1234567890123456
DSC FREQ :	12577.5 KHZ
	RE-SEND

- 3) After the acknowledge able call is sent the display changes as below. Pick up the handset or press the [CALL] key within one minute from the time this message appears. (If the handset is not picked up or the [CALL] key is not pressed within one minute the message “PSTN call canceled. Try calling again?” appears. In this case, press the [ENT] key to re-send the call.)

Pick up the handset or press CALL key!	
FROM COAST :	001234567
TEL NO. :	1234567890123456
TELEPHONE	CH 12001
DSC FREQ :	12577.5 KHZ
TIME TO GO:	60S

No response! Try calling again?	
FROM COAST :	001234567
TEL NO. :	1234567890123456
DSC FREQ :	12577.5 KHZ
	RE-SEND

- 4) The message “PSTN call in progress!” appears. Follow from 2) above.

4.9.3 Receiving PSTN call, sending acknowledge back (ACK BQ)

1. The following display appears when a PSTN call is received.

Able acknowledge call in progress!	
TO COAST :	001234567
TEL NO. :	1234567890123456
TELEPHONE	CH 12001
DSC FREQ :	12577.5 KHZ
TIME TO GO:	8S

2. The timer counts down to zero and the following display appears.

Pick up the handset or press CALL key.	
FROM COAST :	001234567
TEL NO. :	1234567890123456
TELEPHONE	CH 12001
DSC FREQ :	12577.5 KHZ
TIME TO GO:	60S

PSTN call canceled. Try calling again.	
FROM COAST :	001234567
TEL NO. :	1234567890123456
TELEPHONE	CH 12001
DSC FREQ :	12577.5 KHZ
RE-SEND	

3. Pick up the handset or press the [CALL] key within one minute. (If this not done within one minute the call is canceled, displaying the message "PSTN call canceled. Try calling again?". Press the [ENT] key to call.)

PSTN connection call in progress!	
TO COAST :	001234567
TEL NO. :	1234567890123456
TELEPHONE	CH 12001
DSC FREQ :	12230.0 KHZ
TIME TO GO:	8S

4. When the timer counts down to zero the following message appears.

Waiting for acknowledgement.	
FROM COAST :	001234567
TEL NO. :	1234567890123456
TELEPHONE	CH 12001
DSC FREQ :	12230.0 KHZ
TIME TO GO:	25S

5. One of the following messages appears.

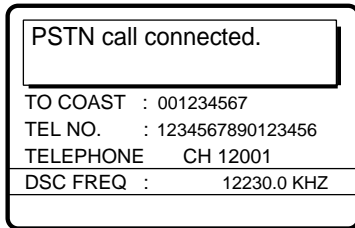

PSTN call connected

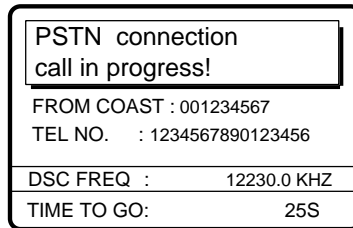

PSTN connection call in progress

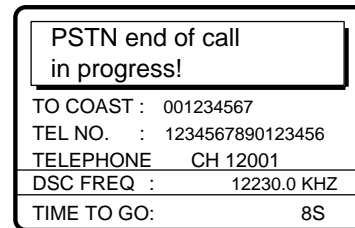

PSTN end of call

6. Do one of the following depending on the message shown at step 5.

PSTN call connected: Your phone rings; pick up the handset and communication with receiving station.

PSTN connection call in progress!: This means coast station has switched DSC frequency. (If the channel cannot be used the message “PSTN end of call in progress!” appears. In this case, start this procedure again.) If the channel assigned is OK the message “Waiting for acknowledgment.” appears.

PSTN end of call in progress!: The channel could not be used. Press the [CANCEL] key to return to the DSC standby screen. Repeat this procedure to send the call again.

4.9.4 PSTN call disconnection, receiving charge information (ship disconnects line)

1. After hanging up the handset or pressing the [CANCEL] key to complete your call the display shows the following message.

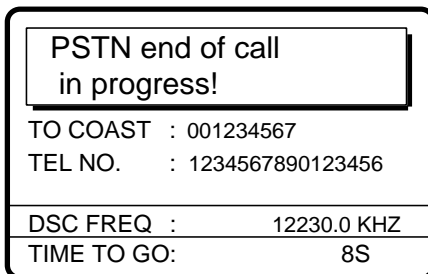

2. After the call is sent one of the following messages appears. (For time out the message “PSTN end of call in progress!” appears. After the timer counts down to zero “Waiting for charge information.” appears.)

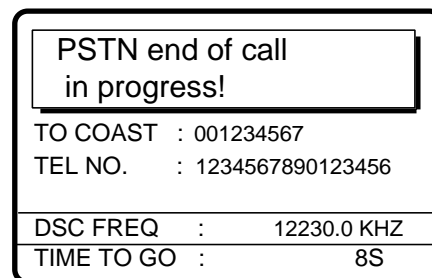
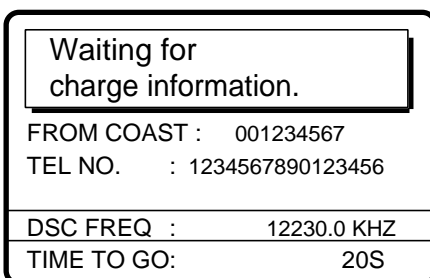

3. When the timer counts down to zero one of the following displays appear.

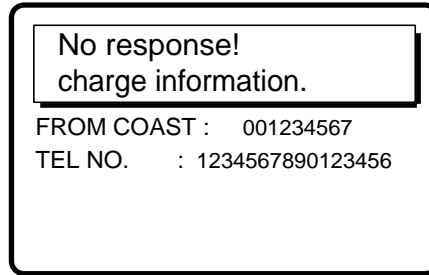
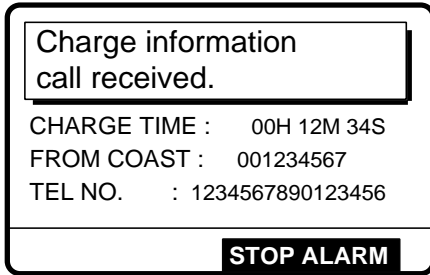

4. For **“No response! charge information.”**, the equipment reverts to step 2 in this procedure to await charge information. For **“Charge information call received.”** the audio alarm sounds; press the [CANCEL] key or [ENT] key to silence the audio alarm. The display shown below appears.



4.9.5 PSTN call disconnection, receiving charge information (coast station disconnects line)

1. The PSTN line is disconnected by the coast station when it finds no evidence of communications or the land subscriber hangs up. The coast station then sends charge information as below.



2. For no charge information the left-hand figure below appears.

