

Rotate the **CHANNEL/ENTER** knob to select [AUDIO] on the [MENU] screen then push the knob.

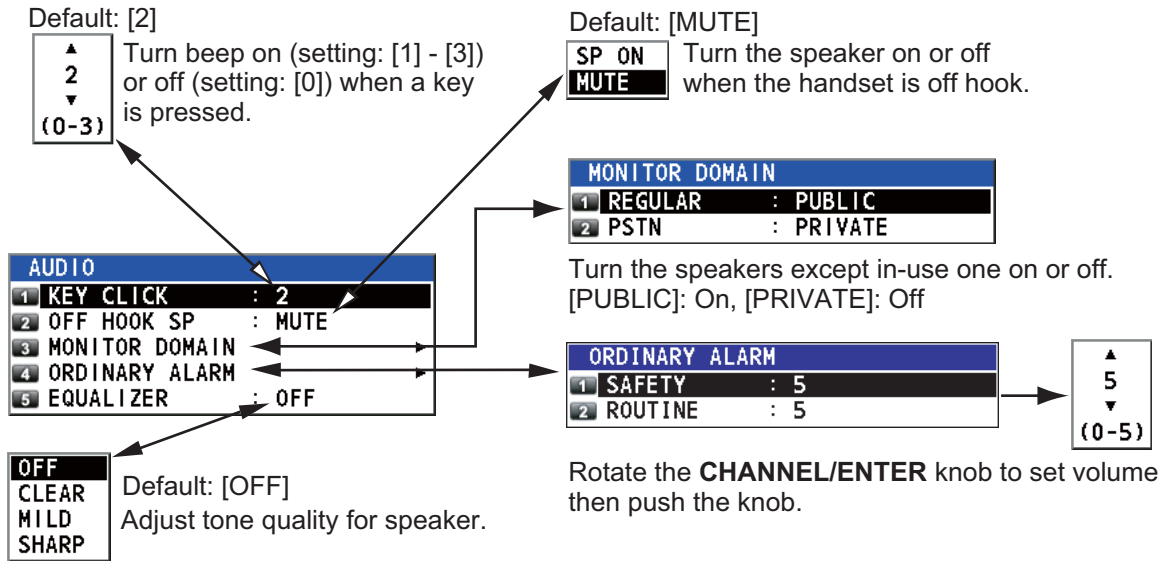

5.20 Alarm Lists

The [ALARM] menu shows all currently violated alarms. When an error occurs, a pop-up message and a flashing error icon appear on the screen. Press the **CANCEL** key to close the pop-up message and stop the flashing of the error icon. When the error is removed, the error icon disappears.

Rotate the **CHANNEL/ENTER** knob to select [ALARM] on the [MENU] screen then push the knob. The following screen appears.

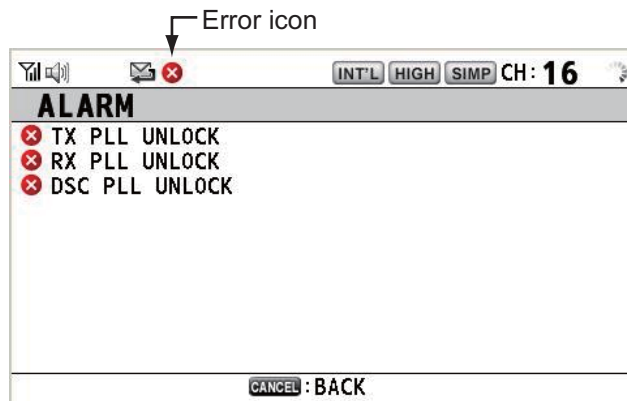

There are three kinds of errors: [TX PLL UNLOCK], [RX PLL UNLOCK], [DSC PLL UNLOCK].

Errors are displayed in the order shown above, not in the order of occurrence. An error is deleted from the list when the cause for the error is removed.

These alarms are listed when the following messages appear.

<p>WARNING</p> <p>TX PLL UNLOCK! CH:XX Unable to transmit.</p> <p>CANCEL : Stop alarm</p>	<p>WARNING</p> <p>RX PLL UNLOCK! CH:XX Unable to receive.</p> <p>CANCEL : Stop alarm</p>	<p>WARNING</p> <p>DSC PLL UNLOCK! CH:70 Unable to receive DSC message.</p> <p>CANCEL : Stop alarm</p>
--	---	--

5. MENU OPERATION

This page is intentionally left blank.

6. REMOTE HANDSET

6.1 Controls

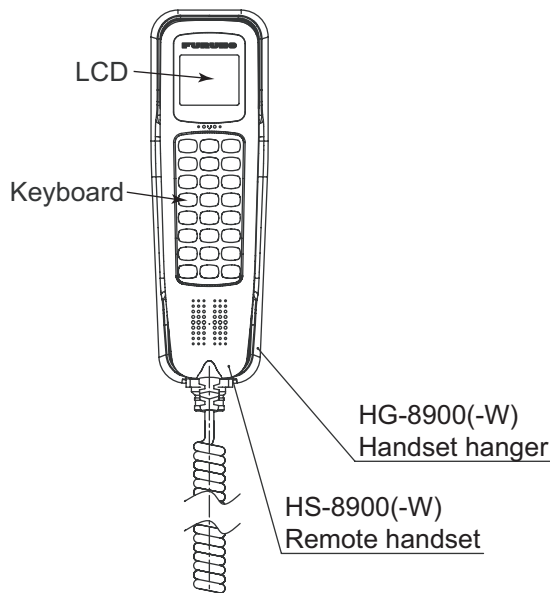

Remote station RB-8900(-W) (option)

Description of controls for remote station (handset)

Control	Function
DW key	Turns the DW function on or off (see section 1.9).
HI/LO key	Changes the output power to high (25 W) or low (1 W).
CH16 key	Switches to the RT (radiotelephone) screen and sets CH16.
SCAN key	Turns the scan function on or off (see section 1.10).
▲, ▼ keys	<ul style="list-style-type: none"> • Selects the menu items. • Selects the channel on the RT screen. • Adjusts the setting values.
SQ key	Adjusts the squelch. Press the SQ key on the RT/OCCUPIED screen then press the ▲ or ▼ key within three seconds to adjust the squelch (setting range: AUTO, 0 to 10). To get auto squelch adjustment, press the ▼ key with the setting 0 (indication: SQA).
VOL key	Adjusts the volume. Press the VOL key on the RT/OCCUPIED screen then press the ▲ or ▼ key within three seconds to adjust the volume (setting range: 0 to 10).
ENTER key	<ul style="list-style-type: none"> • Moves down one layer when you save the menu option in a layer other than the lowest one. In the undermost layer, opens the setting window. • Confirms a selection.
CANCEL key	<ul style="list-style-type: none"> • Silences the audio alarm. • Returns one layer in a multi-layer menu. In the top layer, closes the menu then displays the RT screen. • Cancels the setting in the setting window then goes back one layer in the menu. • Cancels the intercom call.
🔇 key	Turns the loudspeaker on or off.

6. REMOTE HANDSET

Control	Function
MENU key	Opens/closes the menu.
0 to 9 keys	<ul style="list-style-type: none"> Enters the channel on the RT screen. Selects the menu items.
CONTRAST key	<p>Short press: Opens the contrast setup screen. Press the ▲ or ▼ key to adjust the contrast.</p> <p>Long press (more than three seconds): Restores the contrast to the default setting.</p>
BRILL key	Opens the brill setup screen. Press the ▲ or ▼ key to adjust the brill. You can also use the BRILL key.

6.2 How to Turn On/Off the Power

A handset does not have a power key. Turn on or off the power from the transceiver unit.

6.3 Radiotelephone (RT) Screen

Below are the radiotelephone (RT) screens on the remote handset.

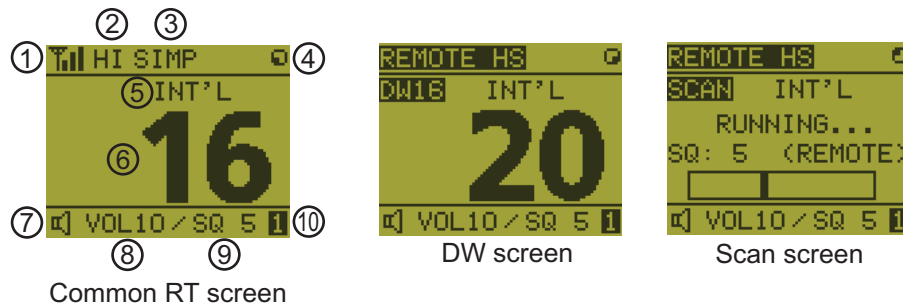

When no terminal has operation right and a remote handset is off hook, the following screen appears.

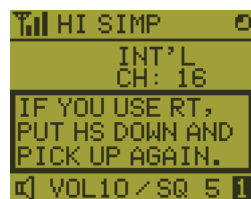

A remote handset can get the operation right if you hook on then hook off.

No.	Meaning
1	RX signal strength (This icon does not appear while transmitting.)
2	Output power ([HI]: High, [LO]: Low)
3	Channel type ([SIMP]: Simplex, [DUP]: Duplex)
4	Spinner rotates when the equipment is functioning normally.
5	Channel region ([INT'L], [USA], [CANADA], [INLAND-W], [PRIVATE])
6	Channel
7	Loudspeaker on ([L]) or off ([L])
8	Volume for loudspeaker (0 to 10)
9	Squelch level (0 to 10, AUTO (Indication is [SQA].))
10	Terminal ID ([L]: Left wing handset, [R]: Right wing handset, [1] to [4]: Remote handset 1 to 4)

6.4 How to Adjust the Brilliance and Contrast

You can adjust the brilliance of the display and the panel for each remote handset separately. Also, you can adjust the contrast for each remote handset.

Brilliance

1. Press the **BRILL** key to show the [BRILL] setting window.
2. Press the **▲** or **▼** key to adjust the brilliance.
3. Press the **ENTER** key to save the settings and close the window. To cancel the settings, press the **CANCEL** key instead of the **ENTER** key to close the window.

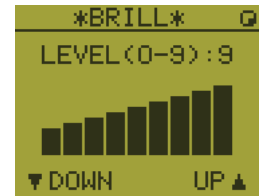

Note: The [BRILL] setting window automatically closes when there is no menu operation for three seconds.

Contrast

1. Press the **CONTRAST** key to show the [CONTRAST] setting window.
2. Press the **▲** or **▼** key to adjust the contrast.
3. Press the **ENTER** key to save the settings and close the window. To cancel the settings, press the **CANCEL** key instead of the **ENTER** key to close the window.



Note: The [CONTRAST] setting window automatically closes when there is no menu operation for three seconds.

6.5 How to Select the Channel Region, Channel

Channel region

1. Press the **MENU** key to open the [MENU] screen.
2. Press the **▲** or **▼** key to select [REGION] then press the **ENTER** key.



3. Press the **▲** or **▼** key to select the channel mode desired then press the **ENTER** key. The following modes are available.
 - [INT'L]: International mode
 - [USA]: USA mode
 - [CANADA]: CANADA mode
 - [INLAND-W]: Inland waterway mode
 - [PRIVATE]: Private channel

6. REMOTE HANDSET

Note 1: Only permitted channel regions are displayed, which are set by the installer of the equipment.

Note 2: Private channels are available only where permitted by the authorities. The [USA], [CANADA], [INLAND-W], [PRIVATE] can also be set by a qualified service technician.

Channel

The channel can be set manually on the RT screen. Enter the channel by one of the methods below.

Enter channel with the ▲ or ▼ key:

Press the ▲ or ▼ key on the RT screen.

Enter channel with the numeric keys:

Use the numeric keys to enter channel on the RT screen. (It is not necessary to press the **ENTER** key after entering the channel; the setting is confirmed one second after it is entered.)

Note: When the transceiver unit is in on hook condition, you can change the channel with the remote handset.

Memory channel

You can easily call up a channel which you registered in the transceiver unit as a memory channel (see section 5.4).

1. Press the **MENU** key to open the [MENU] screen.
2. Press the ▲ or ▼ key to select [MEMORY CH] then press the **ENTER** key.
3. Press the ▲ or ▼ key to select [ON] or [OFF] then press the **ENTER** key. When you select [ON], "M" appears on the screen. On the RT screen, you can select a memory channel by pressing the ▲ or ▼ key. The following figure shows the example for CH 10.

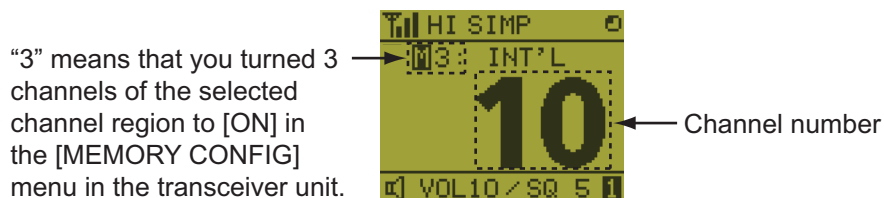

6.6 Transmission

How to transmit

Press the **PTT** (Push-to-talk) switch on the handset to talk, and release it to listen for a response. "TX" appears at the top left-hand corner of the screen during transmission.

How to change the output power

Press the **HI/LO** key to change the output power to high and low alternately. "HI" or "LO" appears on the screen depending on your selection.

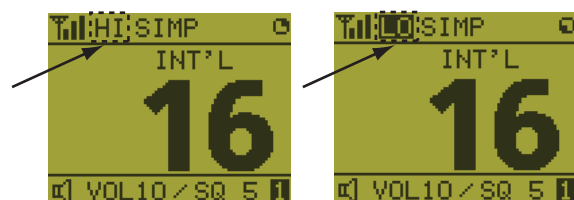

6.7 How to Turn On/Off the Loudspeaker

You can turn the loudspeaker (other than DSC communication, error, and key beep) on or off.

1. Press the **SPK** key to alternately disable or enable the loudspeaker.



Speaker ON



Speaker OFF

2. To adjust the volume of the loudspeaker, press the **VOL** key. The screen changes as below.

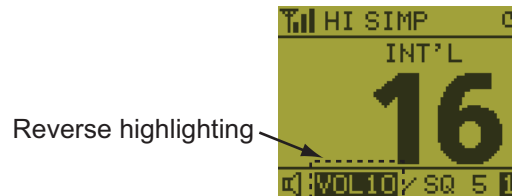

3. Press the **▲** or **▼** key to adjust the volume within three seconds. The time for reverse highlighting is three seconds.

6.8 Quick Selection of CH16

Press the **CH16** key to select CH16. The CH16 (156.8 MHz) is the international frequency for distress traffic and for calling by radiotelephone. The CH16 can also be used by ship stations for call and reply. To facilitate the reception of distress calls and distress traffic, all transmissions on CH16 should be kept to a minimum and should not exceed one minute. Before transmitting on the CH16, a station should listen on this frequency for a reasonable period to make sure that no distress traffic is being sent.

6.9 Intercom

The built-in intercom permits voice communications between two control units. The combination of two controls is transceiver unit & remote handset, or remote handset & remote handset.

Calling

You can call over the intercom only in off hook condition.

1. Press the **MENU** key to open the [MENU] screen.
2. Press the **▲** or **▼** key to select [INTERCOM] then press the **ENTER** key.
3. Press the **▲** or **▼** key to select the called party's control unit then press the **ENTER** key.
The called party's control unit and yours ring.
To cancel calling, press the **CANCEL** key.

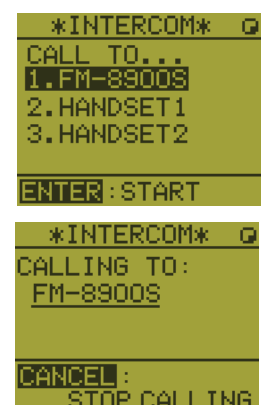

6. REMOTE HANDSET

- When the called party picks up their handset, the screen as shown in the right figure appears. Start communications.

Note: You do not have to press the **PTT** switch to communicate.



- Hang up the handset or press the **CANCEL** or the **CH16** key to turn the intercom off. The RT screen appears.

Answering

- The control unit rings and the following screen appears. To cancel reply, press the **CANCEL** key.



Off hook condition



On hook condition

- Press the **ENTER** key with off hook condition or pick up the handset with on hook condition to start communications.
- Hang up the handset or press the **CANCEL** key to turn the intercom off. The RT screen appears.

Earpiece volume

You can adjust the volume of the earpiece during intercom communication by pressing the **▲** or **▼** key. After intercom communication, the earpiece volume is reverted to the setting value you set on [EARPIECE LEVEL] (see section 6.11).

Note: Neither key click nor key error sounds during intercom communication.

6.10 How to Change the Terminal ID

- Turn off the remote handset by the transceiver unit.
- While you hold the **MENU** key, turn on the remote handset by the transceiver unit. The setting window for terminal ID appears.
- Enter the terminal ID, using the **1** to **6** keys, then press the **ENTER** key. Do not assign the same number to multiple remote stations.

Note: Restart the remote handset by the transceiver unit after changing terminal ID.

6.11 Audio setting

The [AUDIO] menu enables or disables key beep and adjusts the volume of the earpiece and off hook loudspeaker.

Key click

- Press the **MENU** key to open the [MENU] screen.

- Press the ▲ or ▼ key to select [AUDIO] then press the **ENTER** key.



- Press the ▲ or ▼ key to select [KEY CLICK VOLUME] then press the **ENTER** key.

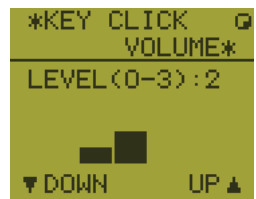

- Press the ▲ or ▼ key to set the key click level (setting range: 0 (OFF), 1, 2 or 3).
- Press the **ENTER** key. To cancel the setting, press the **CANCEL** key.

Earpiece volume

- Press the **MENU** key to open the [MENU] screen.
- Press the ▲ or ▼ key to select [AUDIO] then press the **ENTER** key.
- Press the ▲ or ▼ key to select [EARPIECE LEVEL] then press the **ENTER** key.

Note: Neither key click nor key error sounds during the [EARPIECE LEVEL] display.



- Press the ▲ or ▼ key to set the earpiece volume level (setting range: 1 to 3).
- Press the **ENTER** key. To cancel the setting, press the **CANCEL** key.

Off hook loudspeaker

You can set the loudspeaker on or off according to off hook condition.

- Press the **MENU** key to open the [MENU] screen.
- Press the ▲ or ▼ key to select [AUDIO] then press the **ENTER** key.
- Press the ▲ or ▼ key to select [OFF HOOK SPEAKER] then press the **ENTER** key.

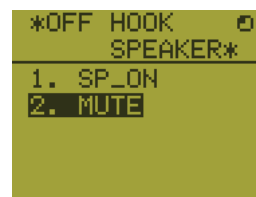

- Press the ▲ or ▼ key to select [SP_ON] or [MUTE].
[SP_ON]: Loudspeaker is activated when off hook.
[MUTE]: Loudspeaker is deactivated when off hook.
- Press the **ENTER** key. To cancel the setting, press the **CANCEL** key.

6.12 How to Test FM-8900S from a Remote Handset

1. Press the **MENU** key to open the [MENU] screen.
2. Press the **▲** or **▼** key to select [DAILY TEST] then press the **ENTER** key.



3. Press the **ENTER** key to start the test. You can confirm the test results for FM-8900S with the **1** or **3** key.

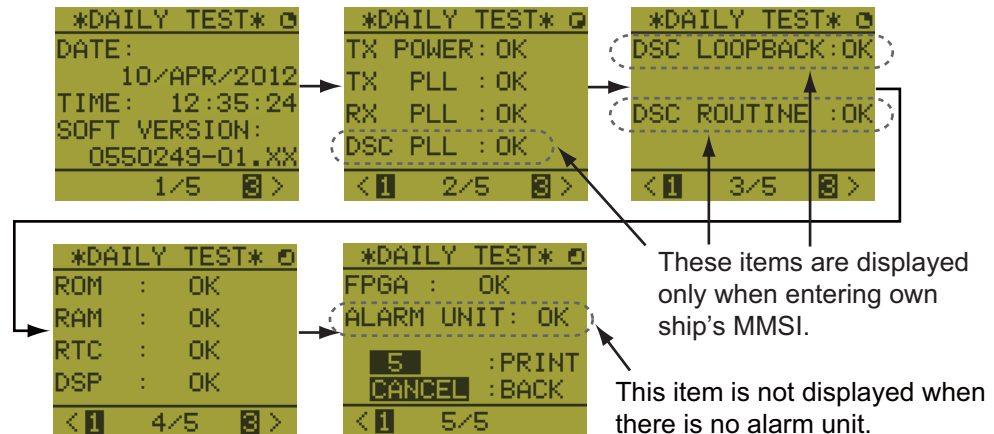

Press the **3** key for the next page and the **1** key for the previous page.

6.13 How to Display the Program Versions

1. Press the **MENU** key to open the [MENU] screen.
2. Press the **▲** or **▼** key to select [VERSION] then press the **ENTER** key. The program versions for FM-8900S and HS-8900 appear.

6.14 Squelch

- The squelch value is common to all remote handsets. If you change a squelch value for a remote handset, squelch values for all other remote handsets are changed accordingly.
- You can not change a squelch value for a remote handset while the squelch is being adjusted by another remote handset.
- When the DW or scan is active, the squelch value from the terminal (transceiver unit or remote handset) that initiated the DW or scan is used.

7. MAINTENANCE & TROUBLESHOOTING

WARNING

ELECTRICAL SHOCK HAZARD
Do not open the equipment.

Only qualified personnel should work inside the equipment.

NOTICE

Do not apply paint, anti-corrosive sealant or contact spray to plastic parts or equipment coating.

Those items contain products that can damage plastic parts and equipment coating.

7.1 Daily Test

Do the daily test to check the radiotelephone for proper operation.

Rotate the **CHANNEL/ENTER** knob to select [TEST] on the [MENU] screen then push the knob. The daily test starts. After the test is completed, the audio alarm sounds and the screen shown below appears. This screen shows:

- Test date
- Program version number
- Test results for TX power, TX PLL, RX PLL, DSC PLL, DSC loopback, DSC routine, ROM, RAM, RTC, DSP, FPGA and alarm unit (only when connecting the alarm unit), shown as [OK] or [NG] (No Good). For NG, contact your dealer for advice. The DSC test checks, using a DSC signal, the encode and decode functions of the signal processor.

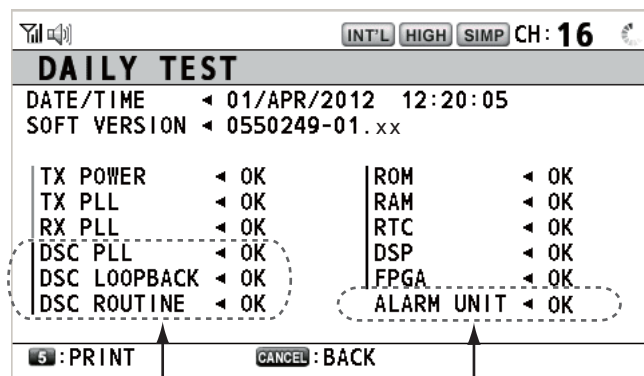

These items are not available when not entering own ship's MMSI.

This item is not available when not connecting the alarm unit.

To print out the test result manually, press the **5** key. Automatic printing of the daily test is available. See section 5.5.

7.2 Maintenance

Regular maintenance helps to keep your equipment in good condition and prevents future problems. Check the items shown in the table below.

Item	Check point	Remedy/Remarks
Antenna	Check for physical damage and corrosion.	Replace damaged parts.
Wire antenna	Check that the antenna is properly spanned and separated sufficiently from metallic structures.	If necessary, re-span antenna.
Insulators for antenna	Check for salt water deposits on insulators. Check that connection at the lead-in insulator is tight and rust-free.	Replace damaged insulator(s). Remove salt water deposits. Clean with fresh water, then dry. Remove rust, then tighten bolts and lock nuts. Cover metallic surface with sealing compound.
Transceiver unit	<ul style="list-style-type: none"> • Check ground connection. • Check connection at signal cable, coaxial cable, control cable, power cable and external equipment (including navigator). • Confirm that there are no objects on the top of the transceiver unit. • Remove dust from transceiver unit with soft cloth. <p>Note: Do not use chemical cleaners to clean the transceiver unit; they can remove paint or markings and deform the equipment.</p>	<ul style="list-style-type: none"> • Tighten the loosened connections; remove foreign materials from connectors. • Remove any objects. • Wipe the LCD carefully to prevent scratching, using tissue paper and an LCD cleaner. To remove dirt or salt deposits, use an LCD cleaner, wiping slowly with tissue paper so as to dissolve the dirt or salt. Change paper frequently so the salt or dirt does not scratch the LCD.
Power supply	Check that the supply voltage at transmission is within the rated range (21.6 to 31.2 VDC at the power connector).	If not within the range, check power source. Low voltage may cause erratic operation.
Power fuse	Check if a power fuse (7A) has blown.	If the fuse has blown, find out the cause before replacing it (Type: FGBO 125V 7A PBF). If it blows after replacement, contact your dealer.

7.3 Simple Troubleshooting

The table below provides possible problems and the means with which to restore normal operation. If normal operation cannot be restored, do not attempt to check inside the equipment. Any servicing should be referred to a qualified technician.

Problem	Probable cause	Remedy
Power cannot be turned on.	<ul style="list-style-type: none"> • Mains switchboard is off. • (DC) voltage is too high or too low. • Battery has discharged, or poor contact at terminals. 	<ul style="list-style-type: none"> • Turn on the mains switchboard. • Check supply voltage. • Recharge the battery and tighten the battery terminals.
Display indications do not appear.	Display brilliance is too low.	Press the BRILL key to adjust the display brilliance.
Power is on but no sound from the main speaker.	Main speaker is off.	Press the  key to turn on the main speaker.
Output power reduced to LOW	Power is automatically reduced to protect against overheating due to continuous transmission.	Wait until the unit cools.

7.4 Warning and Caution Messages

The table below shows error messages, their meanings, and remedies. To delete the messages, press the **CANCEL** key.

Message	Meaning	Remedy
<p>WARNING</p> <p>TX PLL UNLOCK! CH:XX Unable to transmit.</p> <p>CANCEL:Stop alarm</p>	TX PLL unlock. Transmission is disabled.	Contact your dealer.
<p>WARNING</p> <p>Unable to transmit! Hardware error occurs. Check alarm status.</p> <p>CANCEL:Close window</p>	TX PLL unlock error. Transmission is disabled.	Contact your dealer.
<p>WARNING</p> <p>RX PLL UNLOCK! CH:XX Unable to receive.</p> <p>CANCEL:Stop alarm</p>	RX PLL unlock. Reception is disabled.	Contact your dealer.
<p>WARNING</p> <p>DSC PLL UNLOCK! CH:70 Unable to receive DSC message.</p> <p>CANCEL:Stop alarm</p>	DSC (CH70) PLL unlock.	Contact your dealer.
<p>CAUTION</p> <p>EPFS error!</p> <p>CANCEL:Stop alarm</p>	Position data is not input for ten minutes. Note: This message does not appear when [INPUT TYPE] in the [POSITION] menu is set to [MANUAL].	Enter the position.
<p>CAUTION</p> <p>Position data is not updated! Position was older than 4H. Update it.</p> <p>CANCEL:Stop alarm</p>	Position data has not been updated for 4H.	Enter the position.
<p>CAUTION</p> <p>Lost position! Position was older than 23.5H. You must update position!</p> <p>CANCEL:Stop alarm</p>	Position data has not been updated for 23.5H.	Enter the position.
<p>CAUTION</p> <p>The unit will not transmit any DSC call until own ship's MMSI is entered.</p> <p>CANCEL:Stop alarm</p>	You tried to send a DSC message but your MMSI has not been registered in the equipment.	Enter MMSI no. of your ship.
<p>CAUTION</p> <p>Cannot print. Check printer.</p> <p>CANCEL:Stop alarm</p>	Printer trouble. Cannot print.	Check the printer (connection, power, paper).
<p>CAUTION</p> <p>Communication error!</p> <p>CANCEL:Stop alarm</p>	Communication between the transceiver unit and a remote handset is lost for three seconds.	Check the connection with the remote handset. If unsolved, contact your dealer.

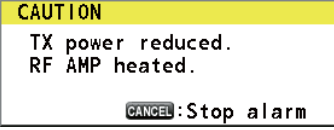
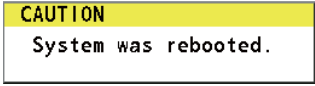
Message	Meaning	Remedy
	RF amplifier is too hot. Transmission power is reduced.	Allow the transceiver unit to cool. If the message appears again, contact your dealer.
	Internal error. System is rebooted.	System automatically restarts. If the problem occurs again, contact your dealer.

7.5 Test Call

This function sends a test signal to a coast or ship station. For that reason, it should not be executed unnecessarily. You can prepare a test call beforehand (see paragraph 5.14.5).

1. Press the **OTHER DSC MSG** key to open the [COMPOSE MESSAGE].
2. Rotate the **CHANNEL/ENTER** knob to select [MSG TYPE] then push the knob.
3. Rotate the **CHANNEL/ENTER** knob to select [TEST MSG] then push the knob. [PRIORITY] is automatically set to [SAFETY].
4. With [TO] selected, push the **CHANNEL/ENTER** knob.
5. Rotate the **CHANNEL/ENTER** knob to select [DIRECT INPUT], [ADDRESS BOOK DATA] or [AIS TARGET DATA] then push the knob.
 [DIRECT INPUT]: Enter the MMSI of the station where to send the call then push the **CHANNEL/ENTER** knob.
 [ADDRESS BOOK DATA]: Select an MMSI from the [ADDRESS BOOK] (see section 5.13) then push the **CHANNEL/ENTER** knob.
 [AIS TARGET DATA]: Select an MMSI from the [AIS TARGET LIST] then push the **CHANNEL/ENTER** knob.
6. With [GO TO CALL] selected, push the **CHANNEL/ENTER** knob to send the test message. The screen is changed to the one for transmission. After the call is sent, the equipment waits for acknowledgement of the call. The timer starts counting up the time to wait for acknowledgement.
7. Do one of the following.

Test acknowledge message received

The audio alarm sounds and the message "TEST ACK received! [CANCEL]: Stop alarm" appears. Press the **CANCEL** key to silence the alarm.

No response

Re-send call: Rotate the **CHANNEL/ENTER** knob to select [RESEND] in the user options area then push the knob.

Cancel call: Rotate the **CHANNEL/ENTER** knob to select [QUIT] in the user options area then push the knob. The message shown in the right figure appears.

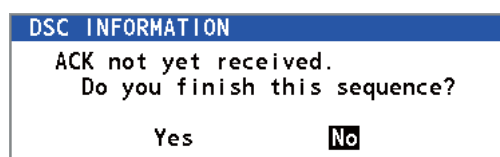

Rotate the **CHANNEL/ENTER** knob to select [Yes] then push the knob.

APPENDIX 1 MENU TREE

Transceiver unit FM-8900S

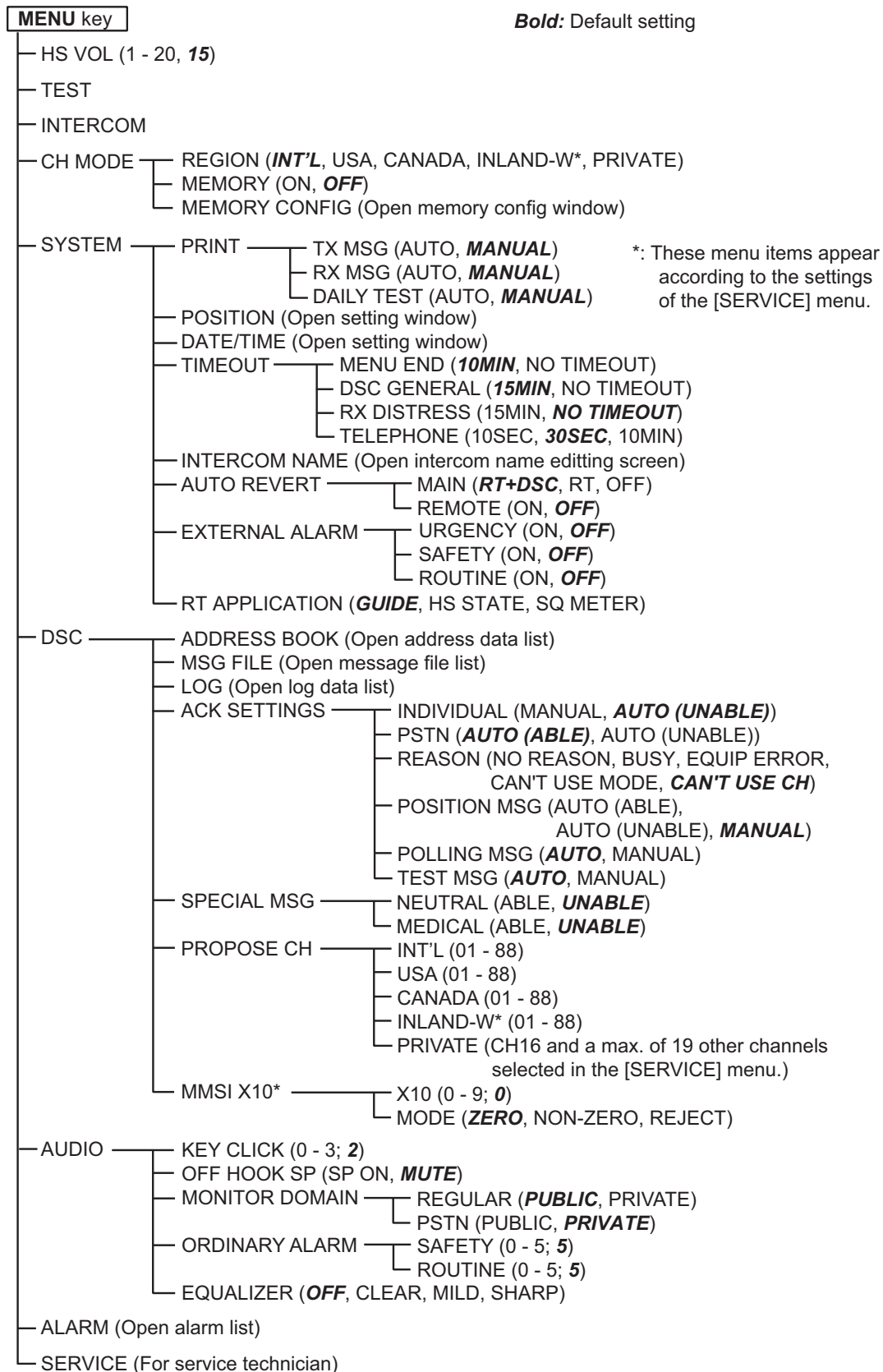

Remote handset HS-8900(-W)

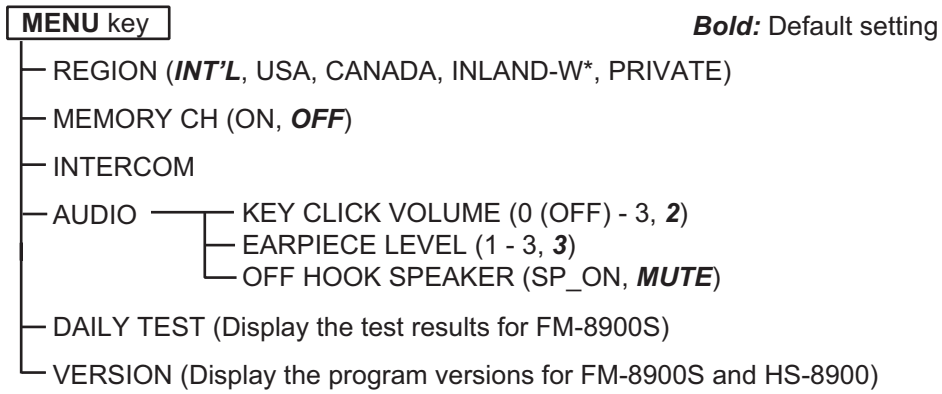

*: This menu item appears according to the setting of the [SERVICE] menu in the FM-8900S.

APPENDIX 2 MARINE VHF CHANNEL LISTS

International channels

CH	TX (MHz)	RX (MHz)	Remark	CH	TX (MHz)	RX (MHz)	Remark
01	156.050	160.650		60	156.025	160.625	
02	156.100	160.700		61	156.075	160.675	
03	156.150	160.750		62	156.125	160.725	
04	156.200	160.800		63	156.175	160.775	
05	156.250	160.850		64	156.225	160.825	
06	156.300	156.300		65	156.275	160.875	
07	156.350	160.950		66	156.325	160.925	
08	156.400	156.400		67	156.375	156.375	
09	156.450	156.450		68	156.425	156.425	
10	156.500	156.500		69	156.475	156.475	
11	156.550	156.550		70	156.525	156.525	DSC
12	156.600	156.600		71	156.575	156.575	
13	156.650	156.650		72	156.625	156.625	
14	156.700	156.700		73	156.675	156.675	
15	156.750	156.750		74	156.725	156.725	
16	156.800	156.800		75	156.775	156.775	Low PWR
17	156.850	156.850		76	156.825	156.825	Low PWR
18	156.900	161.500		77	156.875	156.875	
19	156.950	161.550		78	156.925	161.525	
20	157.000	161.600		79	156.975	161.575	
21	157.050	161.650		80	157.025	161.625	
22	157.100	161.700		81	157.075	161.675	
23	157.150	161.750		82	157.125	161.725	
24	157.200	161.800		83	157.175	161.775	
25	157.250	161.850		84	157.225	161.825	
26	157.300	161.900		85	157.275	161.875	
27	157.350	161.950		86	157.325	161.925	
28	157.400	162.000		87	157.375	157.375	
				88	157.425	157.425	

APPENDIX 2 MARINE VHF CHANNEL LISTS

USA channels

CH	TX (MHz)	RX (MHz)	Remark	CH	TX (MHz)	RX (MHz)	Remark
01	156.050	156.050		60	-	-	
02	-	-		61	-	-	
03	-	-		62	-	-	
04	-	-		63	156.175	156.175	
05	156.250	156.250		64	-	-	
06	156.300	156.300		65	156.275	156.275	
07	156.350	156.350		66	156.325	156.325	
08	156.400	156.400		67	156.375	156.375	Low PWR
09	156.450	156.450		68	156.425	156.425	
10	156.500	156.500		69	156.475	156.475	
11	156.550	156.550		70	156.525	156.525	DSC
12	156.600	156.600		71	156.575	156.575	Low PWR
13	156.650	156.650	Low PWR	72	156.625	156.625	
14	156.700	156.700		73	156.675	156.675	
15	-	156.750		74	156.725	156.725	
16	156.800	156.800		75	156.775	156.775	Low PWR
17	156.850	156.850		76	156.825	156.825	Low PWR
18	156.900	156.900		77	156.875	156.875	Low PWR
19	156.950	156.950		78	156.925	156.925	
20	157.000	157.000		79	156.975	156.975	
21	157.050	157.050	*	80	157.025	157.025	
22	157.100	157.100		81	157.075	157.075	*
23	157.150	157.150	*	82	157.125	157.125	*
24	157.200	161.800		83	157.175	157.175	*
25	157.250	161.850		84	157.225	161.825	
26	157.300	161.900		85	157.275	161.875	
27	157.350	161.950		86	157.325	161.925	
28	157.400	162.000		87	157.375	157.375	
				88	157.425	157.425	

*: USCG (United States Coast Guard) only (General use prohibited)

USA weather channels

WX	RX (MHz)	WX	RX (MHz)
01	162.550	06	162.500
02	162.400	07	162.525
03	162.475	08	161.650
04	162.425	09	161.775
05	162.450	10	163.275

Canadian channels

CH	TX (MHz)	RX (MHz)	Remark	CH	TX (MHz)	RX (MHz)	Remark
01	156.050	160.650		60	156.025	160.625	
02	156.100	160.700		61	156.075	156.075	
03	156.150	160.750		62	156.125	156.125	
04	156.200	156.200		63	156.175	156.175	
05	156.250	156.250		64	156.225	160.825	
06	156.300	156.300		65	156.275	156.275	
07	156.350	156.350		66	156.325	156.325	
08	156.400	156.400		67	156.375	156.375	
09	156.450	156.450		68	156.425	156.425	
10	156.500	156.500		69	156.475	156.475	
11	156.550	156.550		70	156.525	156.525	DSC
12	156.600	156.600		71	156.575	156.575	
13	156.650	156.650		72	156.625	156.625	
14	156.700	156.700		73	156.675	156.675	
15	156.750	156.750	Low PWR	74	156.725	156.725	
16	156.800	156.800		75	156.775	156.775	Low PWR
17	156.850	156.850	Low PWR	76	156.825	156.825	Low PWR
18	156.900	156.900		77	156.875	156.875	
19	156.950	156.950		78	156.925	156.925	
20	157.000	161.600	Low PWR	79	156.975	156.975	
21	157.050	157.050	*	80	157.025	157.025	
22	157.100	157.100	**	81	157.075	157.075	*
23	157.150	161.750		82	157.125	157.125	*
24	157.200	161.800		83	157.175	157.175	*
25	157.250	161.850		84	157.225	161.825	
26	157.300	161.900		85	157.275	161.875	
27	157.350	161.950		86	157.325	161.925	
28	157.400	162.000		87	157.375	157.375	
				88	157.425	157.425	

*: DFO/Canadian Coast Guard only

**: For communications between the Coast Guard and non-Coast Guard stations only

Canadian weather channels

WX	RX (MHz)	WX	RX (MHz)
01	162.550	06	162.500
02	162.400	07	162.525
03	162.475	08	161.650
04	162.425	09	161.775
05	162.450	10	163.275

APPENDIX 2 MARINE VHF CHANNEL LISTS

Inland waterways (INLAND-W) channels

CH	TX (MHz)	RX (MHz)	Remark	CH	TX (MHz)	RX (MHz)	Remark
01	156.050	160.650		60	156.025	160.625	
02	156.100	160.700		61	156.075	160.675	
03	156.150	160.750		62	156.125	160.725	
04	156.200	160.800		63	156.175	160.775	
05	156.250	160.850		64	156.225	160.825	
06	156.300	156.300	Low PWR	65	156.275	160.875	
07	156.350	160.950		66	156.325	160.925	
08	156.400	156.400	Low PWR	67	156.375	156.375	
09	156.450	156.450		68	156.425	156.425	
10	156.500	156.500	Low PWR	69	156.475	156.475	
11	156.550	156.550	Low PWR	70	156.525	156.525	DSC
12	156.600	156.600	Low PWR	71	156.575	156.575	Low PWR
13	156.650	156.650	Low PWR	72	156.625	156.625	Low PWR
14	156.700	156.700	Low PWR	73	156.675	156.675	
15	156.750	156.750	Low PWR	74	156.725	156.725	Low PWR
16	156.800	156.800		75	156.775	156.775	Low PWR
17	156.850	156.850	Low PWR	76	156.825	156.825	Low PWR
18	156.900	161.500		77	156.875	156.875	Low PWR
19	156.950	161.550		78	156.925	161.525	
20	157.000	161.600		79	156.975	161.575	
21	157.050	161.650		80	157.025	161.625	
22	157.100	161.700		81	157.075	161.675	
23	157.150	161.750		82	157.125	161.725	
24	157.200	161.800		83	157.175	161.775	
25	157.250	161.850		84	157.225	161.825	
26	157.300	161.900		85	157.275	161.875	
27	157.350	161.950		86	157.325	161.925	
28	157.400	162.000		87	157.375	157.375	
				88	157.425	157.425	

Private channels

TX (MHz) Simplex/Semi-duplex	RX (MHz)		CH no. (current)	Remark
	Simplex	Semi-duplex		
155.000	155.000	159.600	180	
155.025	155.025	159.625	181	
155.050	155.050	159.650	182	
155.075	155.075	159.675	183	
155.100	155.100	159.700	184	
155.125	155.125	159.725	185	
155.150	155.150	159.750	186	
155.175	155.175	159.775	187	
155.200	155.200	159.800	188	
155.225	155.225	159.825	189	
155.250	155.250	159.850	190	
155.275	155.275	159.875	191	
155.300	155.300	159.900	192	
155.325	155.325	159.925	193	
155.350	155.350	159.950	194	
155.375	155.375	159.975	195	
155.400	155.400	160.000	196	
155.425	155.425	160.025	197	
155.450	155.450	160.050	198	
155.475	155.475	160.075	199	
155.500	155.500	160.100	120(L1)	
155.525	155.525	160.125	121(L2)	
155.550	155.550	160.150	122	
155.575	155.575	160.175	123	
155.600	155.600	160.200	124	
155.625	155.625	160.225	125(F1)(P1)	
155.650	155.650	160.250	126(L3)	
155.675	155.675	160.275	127	
155.700	155.700	160.300	128	
155.725	155.725	160.325	129	
155.750	155.750	160.350	130	
155.775	155.775	160.375	131(F2)(P2)	
155.800	155.800	160.400	132	
155.825	155.825	160.425	133(F3)(P3)	
155.850	155.850	160.450	134	
155.875	155.875	160.475	135	
155.900	155.900	160.500	136	
155.925	155.925	160.525	137	
155.950	155.950	160.550	138	
155.975	155.975	160.575	139	

- Continued -

APPENDIX 2 MARINE VHF CHANNEL LISTS

TX (MHz) Simplex/Semi-duplex	RX (MHz)		CH no. (current)	Remark
	Simplex	Semi-duplex		
156.000	156.000	160.600	00	
156.025	156.025	160.625	60	
156.050	156.050	160.650	01	
156.075	156.075	160.675	61	
156.100	156.100	160.700	02	
156.125	156.125	160.725	62	
156.150	156.150	160.750	03	
156.175	156.175	160.775	63	
156.200	156.200	160.800	04	
156.225	156.225	160.825	64	
156.250	156.250	160.850	05	
156.275	156.275	160.875	65	
156.300	156.300	160.900	06	
156.325	156.325	160.925	66	
156.350	156.350	160.950	07	
156.375	156.375	160.975	67	
156.400	156.400	161.000	08	
156.425	156.425	161.025	68	
156.450	156.450	161.050	09	
156.475	156.475	161.075	69	
156.500	156.500	161.100	10	
156.525	156.525	161.125	70	
156.550	156.550	161.150	11	
156.575	156.575	161.175	71	
156.600	156.600	161.200	12	
156.625	156.625	161.225	72	
156.650	156.650	161.250	13	
156.675	156.675	161.275	73	
156.700	156.700	161.300	14	
156.725	156.725	161.325	74	
156.750	156.750	161.350	15	
156.775	156.775	161.375	75	
156.800	156.800	161.400	16	
156.825	156.825	161.425	76	
156.850	156.850	161.450	17	
156.875	156.875	161.475	77	
156.900	156.900	161.500	18	
156.925	156.925	161.525	78	
156.950	156.950	161.550	19	
156.975	156.975	161.575	79	
157.000	157.000	161.600	20	
157.025	157.025	161.625	80	
157.050	157.050	161.650	21	
157.075	157.075	161.675	81	
157.100	157.100	161.700	22	

- Continued -

APPENDIX 2 MARINE VHF CHANNEL LISTS

TX (MHz) Simplex/Semi-duplex	RX (MHz)		CH no. (current)	Remark
	Simplex	Semi-duplex		
157.125	157.125	161.725	82	
157.150	157.150	161.750	23	
157.175	157.175	161.775	83	
157.200	157.200	161.800	24	
157.225	157.225	161.825	84	
157.250	157.250	161.850	25	
157.275	157.275	161.875	85	
157.300	157.300	161.900	26	
157.325	157.325	161.925	86	
157.350	157.350	161.950	27	
157.375	157.375	161.975	87	
157.400	157.400	162.000	28	
157.425	157.425	162.025	88	
157.450	157.450	162.050	29	
157.475	157.475	162.075	89	
157.500	157.500	162.100	30	
157.525	157.525	162.125	90	
157.550	157.550	162.150	31	
157.575	157.575	162.175	91	
157.600	157.600	162.200	32	
157.625	157.625	162.225	92	
157.650	157.650	162.250	33	
157.675	157.675	162.275	93	
157.700	157.700	162.300	34	
157.725	157.725	162.325	94	
157.750	157.750	162.350	35	
157.775	157.775	162.375	95	
157.800	157.800	162.400	36	
157.825	157.825	162.425	96	
157.850	157.850	162.450	37(M1)	
157.875	157.875	162.475	97	
157.900	157.900	162.500	38	
157.925	157.925	162.525	98	
157.950	157.950	162.550	39	
157.975	157.975	162.575	99	
158.000	158.000	162.600	40	
158.025	158.025	162.625	100	
158.050	158.050	162.650	41	
158.075	158.075	162.675	101	
158.100	158.100	162.700	42	
158.125	158.125	162.725	102	
158.150	158.150	162.750	43	
158.175	158.175	162.775	103	
158.200	158.200	162.800	44	
158.225	158.225	162.825	104	
158.250	158.250	162.850	45	

- Continued -

APPENDIX 2 MARINE VHF CHANNEL LISTS

TX (MHz) Simplex/Semi-duplex	RX (MHz)		CH no. (current)	Remark
	Simplex	Semi-duplex		
158.275	158.275	162.875	105	
158.300	158.300	162.900	46	
158.325	158.325	162.925	106	
158.350	158.350	162.950	47	
158.375	158.375	162.975	107	
158.400	158.400	163.000	48	
158.425	158.425	163.025	108	
158.450	158.450	163.050	49	
158.475	158.475	163.075	109	
158.500	158.500	163.100	50	
158.525	158.525	163.125	110	
158.550	158.550	163.150	51	
158.575	158.575	163.175	111	
158.600	158.600	163.200	52	
158.625	158.625	163.225	112	
158.650	158.650	163.250	53	
158.675	158.675	163.275	113	
158.700	158.700	163.300	54	
158.725	158.725	163.325	114	
158.750	158.750	163.350	55	
158.775	158.775	163.375	115	
158.800	158.800	163.400	56	
158.825	158.825	163.425	116	
158.850	158.850	163.450	57	
158.875	158.875	163.475	117	
158.900	158.900	163.500	58	
158.925	158.925	163.525	118	
158.950	158.950	163.550	59	
158.975	158.975	163.575	119	
159.000	159.000	163.600	200	
159.025	159.025	163.625	201	
159.050	159.050	163.650	202	
159.075	159.075	163.675	203	
159.100	159.100	163.700	204	
159.125	159.125	163.725	205	
159.150	159.150	163.750	206	
159.175	159.175	163.775	207	
159.200	159.200	163.800	208	
159.225	159.225	163.825	209	
159.250	159.250	163.850	210	
159.275	159.275	163.875	211	
159.300	159.300	163.900	212	
159.325	159.325	163.925	213	
159.350	159.350	163.950	214	
159.375	159.375	163.975	215	
159.400	159.400	164.000	216	

- Continued -

APPENDIX 2 MARINE VHF CHANNEL LISTS

TX (MHz) Simplex/Semi-duplex	RX (MHz)		CH no. (current)	Remark
	Simplex	Semi-duplex		
159.425	159.425	164.025	217	
159.450	159.450	164.050	218	
159.475	159.475	164.075	219	
159.500	159.500	164.100	220	
159.525	159.525	164.125	221	
159.550	159.550	164.150	222	
159.575	159.575	164.175	223	
159.600	159.600	164.200	224	
159.625	159.625		225	
159.650	159.650		226	
159.675	159.675		227	
159.700	159.700		228	
159.725	159.725		229	
159.750	159.750		230	
159.775	159.775		231	
159.800	159.800		232	
159.825	159.825		233	
159.850	159.850		234	
159.875	159.875		235	
159.900	159.900		236	
159.925	159.925		237	
159.950	159.950		238	
159.975	159.975		239	
160.000	160.000		240	
160.025	160.025		241	
160.050	160.050		242	
160.075	160.075		243	
160.100	160.100		244	
160.125	160.125		245	
160.150	160.150		246	
160.175	160.175		247	
160.200	160.200		248	
160.225	160.225		249	
160.250	160.250		250	
160.275	160.275		251	
160.300	160.300		252	
160.325	160.325		253	
160.350	160.350		254	
160.375	160.375		255	
160.400	160.400		256	
160.425	160.425		257	
160.450	160.450		258	
160.475	160.475		259	
160.500	160.500		140	
160.525	160.525		141	
160.550	160.550		142	

- Continued -

APPENDIX 2 MARINE VHF CHANNEL LISTS

TX (MHz)	RX (MHz)		CH no. (current)	Remark
	Simplex	Semi-duplex		
160.575	160.575		143	
160.600	160.600		144	
160.625	160.625		145	
160.650	160.650		146	
160.675	160.675		147	
160.700	160.700		148	
160.725	160.725		149	
160.750	160.750		150	
160.775	160.775		151	
160.800	160.800		152	
160.825	160.825		153	
160.850	160.850		154	
160.875	160.875		155	
160.900	160.900		156	
160.925	160.925		157	
160.950	160.950		158	
160.975	160.975		159	
161.000	161.000		160	
161.025	161.025		161	
161.050	161.050		162	
161.075	161.075		163	
161.100	161.100		164	
161.125	161.125		165	
161.150	161.150		166	
161.175	161.175		167	
161.200	161.200		168	
161.225	161.225		169	
161.250	161.250		170	
161.275	161.275		171	
161.300	161.300		172	
161.325	161.325		173	
161.350	161.350		174	
161.375	161.375		175	
161.400	161.400		176	
161.425	161.425		177(M2)	
161.450	161.450		178	
161.475	161.475		179	

APPENDIX 3 ABBREVIATIONS LIST

Abbreviations

Abbreviation	Term	Abbreviation	Term
ACK	Acknowledge	LAT	Latitude
AIS	Automatic Identification System	LO	Low
ALARM	Alarm	LOG	Log
ANT	Antenna	LON	Longitude
APP	Application	LV	Level
APR	April	MAR	March
AUG	August	MEM	Memory
AUTO	Automatic	MENU	Menu
BRILL	Brilliance	MIN	Minute(s)
CAN'T	Cannot	MMSI	Maritime Mobile Services Identity
CH	Channel	MSG	Message
COMM	Communication	MUTE	Mute
CPU	Central Processing Unit	N	North
DATE	Date	NAV	Navigation
DEC	December	NG	No Good
DSC	Digital Selective Calling	NOV	November
DSP	Digital Signal Processor	OCT	October
DUP	Duplex	OFF	Off
DW	Dual Watch	ON	On
E	East	PLL	Phase Locked Loop
ECC	Error Correction Code	PSTN	Public Switched Telephone Network
ENT	Enter	PWR	Power
EPFS	Electronic Position Fixing System	RAM	Random Access Memory
EQUIP	Equipment	REF	Reference
FEB	February	RF	Radio Frequency
FPGA	Field Programmable Gate Array	ROM	Read Only Memory
FREQ	Frequency	RT	Radiotelephone
GMDSS	Global Maritime Distress and Safety System	RTC	Real Time Clock
GNSS	Global Navigation Satellite System	RX	Receive
HI	High	S-DUP	Semi-Duplex
HS	Handset	SEC	Second(s)
INFO	Information	SEP	September
INLAND-W	Inland Waterway	SIMP	Simplex
INS	Integrated Navigation System	SP	Speaker
INTERCOM	Intercommunication System	SQ	Squelch
INT'L	International	TIME	Time
JAN	January	TRX	Transmit and Receive
JUL	July	TX	Transmit
JUN	June	USA	United States of America

APPENDIX 3 ABBREVIATIONS LIST

Abbreviation	Term	Abbreviation	Term
UTC	Coordinated Universal Time/ Universal Time, Coordinated	VOL	Volume
VDR	Voyage Data Recorder	WR	Watchkeeping Receiver

Icons

Icon	Meaning	Icon	Meaning
	Speaker ON		Number keys
	Speaker OFF		CHANNEL/ENTER knob
	Unread message		Name of the ship registered in address book
	Auto ACK for individual message is ON.		Name of the ship registered in AIS target list
	Radio field intensity on the RT screen		Data is being updated regularly.
	Radio field intensity on the screens except the RT screen		Unsolved error
	Send a distress alert of your ship.		Transmitting
	<ul style="list-style-type: none"> Receive a distress alert from a ship in distress. Send a distress relay on behalf of a ship in distress. 		Channel region is INT'L.
	Send a general (safety, urgency or routine) message.		Channel region is USA.
	Receive a general (safety, urgency or routine) message.		Channel region is WX.
	Communicate via radiotelephone		Channel region is CANADA.
	Equalizer mode is on.		Channel region is INLAND-W.
	Output power is high.		Channel region is PRIVATE.
	Output power is low.		Channel region is MEMORY.
	Simplex frequency		Dual watching
	Duplex frequency		Scanning
	Distress frequency		Squelch is opened.

APPENDIX 4 DIGITAL INTERFACE (IEC 61162-1)

I/O Sentences

Input sentences (IEC 61162-1)

GGA, GLL, ZDA, GNS, RMC, VDM

Input sentence description

- GGA - Global positioning system (GPS) fix data

```
$**GGA,hhmmss.ss,lll.lll,a,yyyy.yy,a,x,xx,x.x,x.x,M,x.x,M,x.x,xxxx*hh<CR><LF>  
      1      2 3      4 5 6 7 8 9 10 11 12 13 14
```

1. UTC of position (000000.00 - 235959.99)
2. Latitude (0000.0000 - 9000.0000)
3. N/S
4. Longitude (00000.0000 - 18000.0000)
5. E/W
6. GPS quality indicator (1 - 5)
7. Number of satellite in use (no use)
8. Horizontal dilution of precision (no use)
9. Antenna altitude above/below mean sealevel (no use)
10. Unit, m
11. Geoidal separation (no use)
12. Unit, m
13. Age of differential GPS data (no use)
14. Differential reference station ID (no use)

- GLL - Geographic position - latitude/longitude

```
$**GLL,lll.ll,a,yyyy.yy,a,hhmmss.ss,a,x*hh<CR><LF>  
      1 2      3 4      5      6 7
```

1. Latitude (0000.0000 - 9000.0000)
2. N/S
3. Longitude (00000.0000 - 18000.0000)
4. E/W
5. UTC of position (000000.00 - 235959.99)
6. Status (A=data valid V=data invalid)
7. Mode indicator (A=Autonomous D=Differential
N=No fix S=Simulator mode)

- ZDA - Time and date

```
$**ZDA,hhmmss.ss,xx,xx,xxxx,xx,xx*hh<CR><LF>  
      1      2 3 4 5 6
```

1. UTC (000000.00 - 235959.99)
2. Day (01 - 31)
3. Month (01 - 12)
4. Year (2000 - 2049)
5. Local zone, hours (no use)
6. Local zone, minutes (no use)

- GNS - GNSS fix data

```
$**GNS,hhmmss.ss,llll.ll,a,yyyyy.yy,a,c--c,xx,x.x,x.x,x.x,x.x,x.x,x.x,a*hh<CR><LF>
      1      2 3 4      5 6 7 8 9 10 11 12 13
```

1. UTC of position (000000.00 - 235959.99)
2. Latitude (0000.0000 - 9000.0000)
3. N/S
4. Longitude (00000.0000 - 18000.0000)
5. E/W
6. Mode indicator
N=No fix A=Autonomous D=Differential P=Precise R=Real Time Kinematic
F=Float RTK S=Simulator Mode
7. Total number of satellites in use (00 - 99)
8. HDOP (no use)
9. Antenna altitude, meters (no use)
10. Geoidal separation (no use)
11. Age of differential data (no use)
12. Differential reference station ID (no use)
13. Navigational status indicator (S=Safe C=Caution U=Unsafe V=Navigational status not valid)

- RMC - Recommended minimum specific GNSS data

```
$**RMC,hhmmss.ss,A,llll.ll,a,yyyyy.yy,a,x.x,x.x,ddmmyy,x.x,a,a,a*hh<CR><LF>
      1      2 3 4      5 6 7 8      9 10 11 12 13
```

1. UTC of position fix (000000.00 - 235959.99)
2. Status (A=data valid, V=navigation receiver warning)
3. Latitude (0000.0000 - 9000.0000)
4. N/S
5. Longitude (00000.0000 - 18000.0000)
6. E/W
7. Speed over ground, knots (no use)
8. Course over ground, degrees true (no use)
9. Date (010100 - 311249)
10. Magnetic variation, degrees (no use)
11. E/W
12. Mode indicator (A=Autonomous D=Differential
F=Float RTK N=No fix P=Precise R=Real time kinematic S=Simulator mode)
13. Navigational status indicator (S=Safe C=Caution U=Unsafe V=Navigational status not valid)

- VDM - UAIS VHF data-link message

```
$**VDM,x,x,x,a,s--s,x,*hh<CR><LF>
      1 2 3 4 5 6
```

1. Total number of sentences needed to transfer the message (1 to 9)
2. Message sentence number (1 to 9)
3. Sequential message identifier (0 to 9, NULL)
4. AIS channel Number (A or B)
5. Encapsulated ITU-R M.1371 radio message (1 - 63 bytes)
6. Number of fill-bits (0 to 5)

Output sentences (IEC 61162-1)

DSC, DSE, TLL

Output sentence description

- DSC - Digital selective calling information

```
$CVDSC,xx,xxxxxxxxxx,xx,xx,xx,x.x,x.x,xxxxxxxxxx,xx,a,a*hh<CR><LF>
      1      2      3 4 5 6 7      8      9 10 11
```

1. Format specifier (2 digits)
2. Address (10 digits)
3. Category (2 digits or NULL)
4. Nature of Distress or first telecommand (2 digits or NULL)
5. Type of Communication or second telecommand (2 digits)
6. Position or Channel /Frequency (Max. 12 digits)
7. Time or Tel. No. (Max. 16 digits)
8. MMSI of ship in distress (10 digits or NULL)
9. Nature of distress (2 digits or NULL)
10. Acknowledgement (R=Acknowledge request B=Acknowledgement S=Neither (end of sequence))
11. Expansion indicator (E or NULL)

- DSE - Expanded digital selective calling

```
$CVDSE,x,x,a,xxxxxxxxxx,xx,c--c,.....,xx,c--c*hh<CR><LF>
      1 2 3      4      5 6      7 8 9
```

1. Total number of sentences (fixed value)
2. Sentence number (fixed value)
3. Query/reply flag (fixed value A=Automatic)
4. Vessel MMSI (10 digits)
5. Data set '1' (code field, fixed value 00)
6. Data set '1' (data field, Enhanced position resolution, Max. 8 characters), NULL
7. Additional data sets*, NULL
8. Data set 'n' (NULL)*
9. Data set 'n' (NULL)*

*: This equipment outputs only "Data set 1".

- TLL - Target latitude and longitude

```
$CVTLL,xx,llll.ll,a,yyyy.yy,a,c--c,hhmmss.ss,a,a*hh<CR><LF>
      1 2 3 4      5 6      7      8 9
```

1. Target number, NULL
2. Latitude (0.0000 - 9000.0000)
3. N/S
4. Longitude (0.0000 - 18000.0000)
5. E/W
6. Target name, NULL
7. UTC of data (000000 - 235959)
8. Target status, NULL
9. Reference target, NULL

P - sentences

pireq, pidat, CVdmr, CVdma

P - sentence description

- PFEC,pireq - Equipment information request

\$ PFEC, pirq, sentence

When this sentence is input, the equipment outputs the PFEC,pidat sentence.

- PFEC,pidat - Equipment information

\$ PFEC, pidat, sentence

- PFEC,CVdmr - Digital selective call Message call Request

\$ PFEC, CVdmr, sentence

- PFEC,CVdma - Digital selective call Message call Acknowledgement

\$ PFEC, CVdma, sentence

Schematic diagram

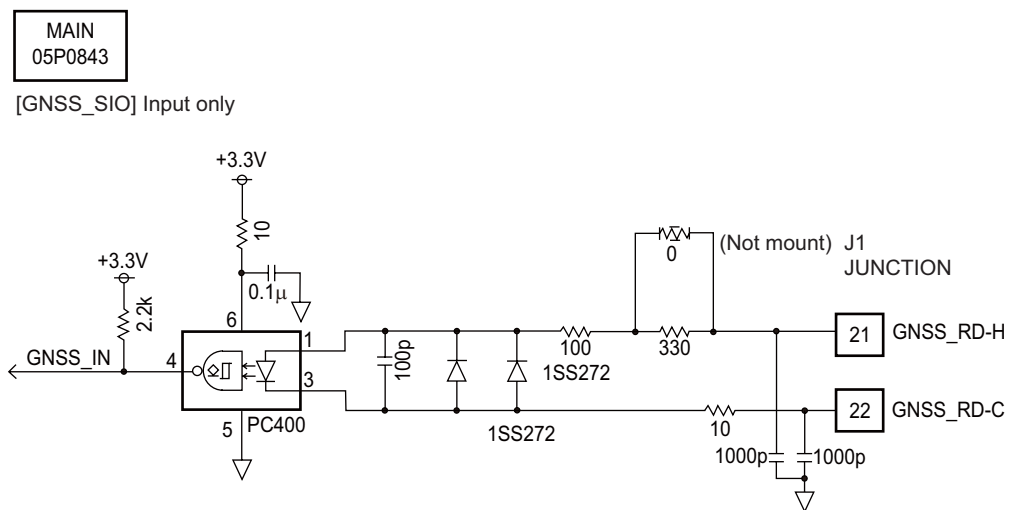

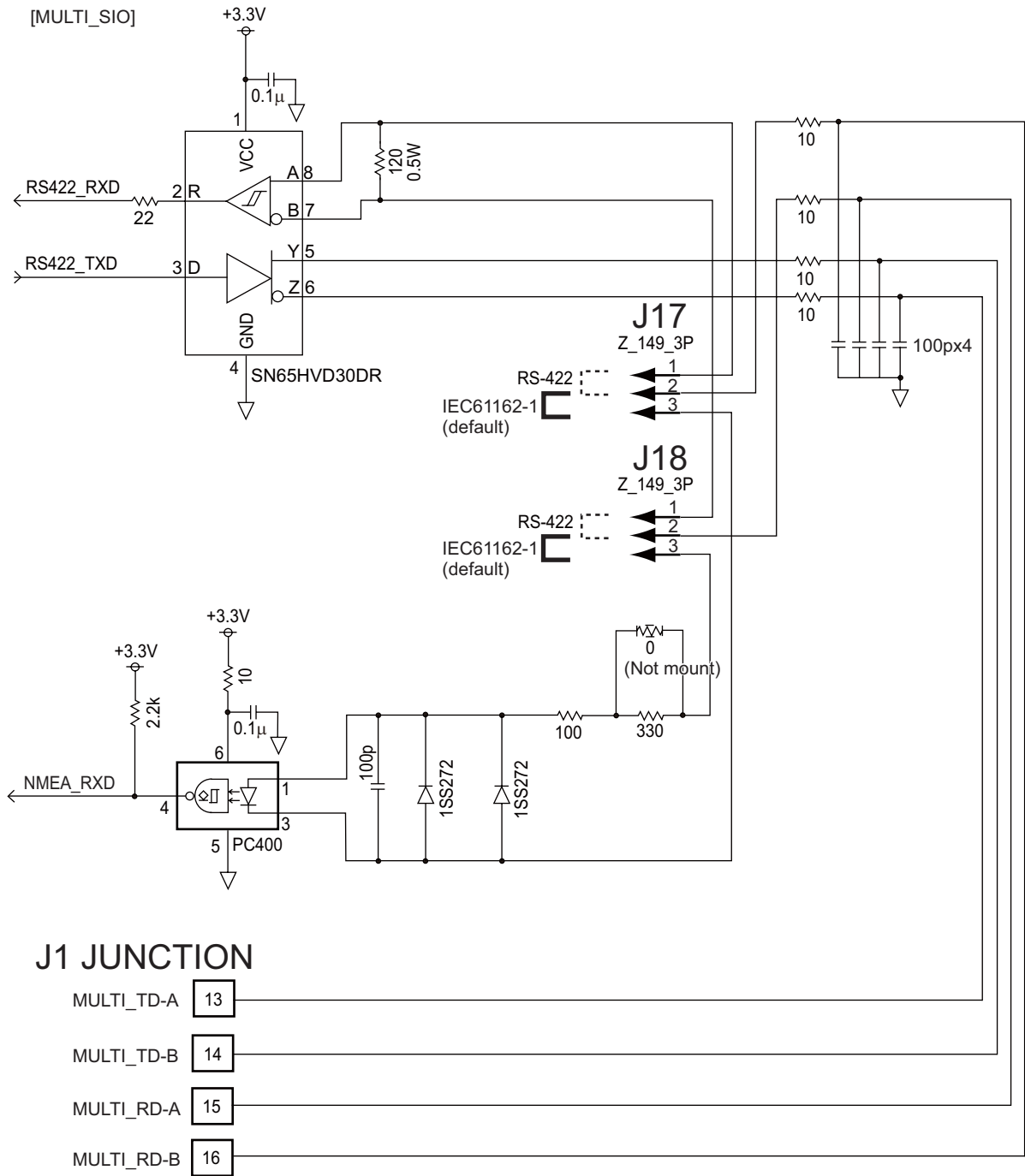

Load requirements as a listener

Isolation: Optocoupler Input impedance: 430Ω Max. voltage: ±15 V Threshold: 4 mA

APPENDIX 5 PARTS LIST

This equipment contains complex modules in which fault diagnosis and repair down to component level are not practical (IMO A.694(17)/8.3.1). Only some discrete components are used. FURUNO Electric Co., Ltd. Believes identifying these components is of no value for shipboard maintenance; therefore, they are not listed in this manual. Major modules can be located on the parts location photos on pages AP-21 thru AP-22.

Transceiver Unit FM-8900S

ELECTRICAL PARTS LIST		Unit	Transceiver Unit FM-8900S
PRINTED CIRCUIT BOARD		Code No.	
05P0843, MAIN		—	
05P0841, TRX_WR		—	
05P0849, PWR		—	
05P0882, PANEL		—	

Handset HS-2003

ELECTRICAL PARTS LIST		Unit	Handset HS-2003
PRINTED CIRCUIT BOARD		Code No.	
05P0780, HANDSET		—	

Remote Handset HS-8900(-W)

ELECTRICAL PARTS LIST		Unit	Remote Handset HS-8900(-W)
PRINTED CIRCUIT BOARD		Code No.	
05P0781B, HS CONT		—	
05P0715, KEY		—	

Remote Handset Hanger HG-8900(-W)

ELECTRICAL PARTS LIST		Unit	Remote Handset Hanger HG-8900(-W)
PRINTED CIRCUIT BOARD		Code No.	
05P0798, TB		—	

Junction Box IF-8900

ELECTRICAL PARTS LIST		Unit	Junction Box IF-8900
PRINTED CIRCUIT BOARD		Code No.	
05P0850, JUNCTION		—	

APPENDIX 6 PARTS LOCATION

Transceiver unit FM-8900S

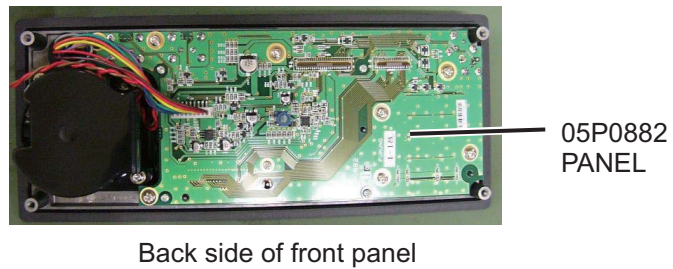
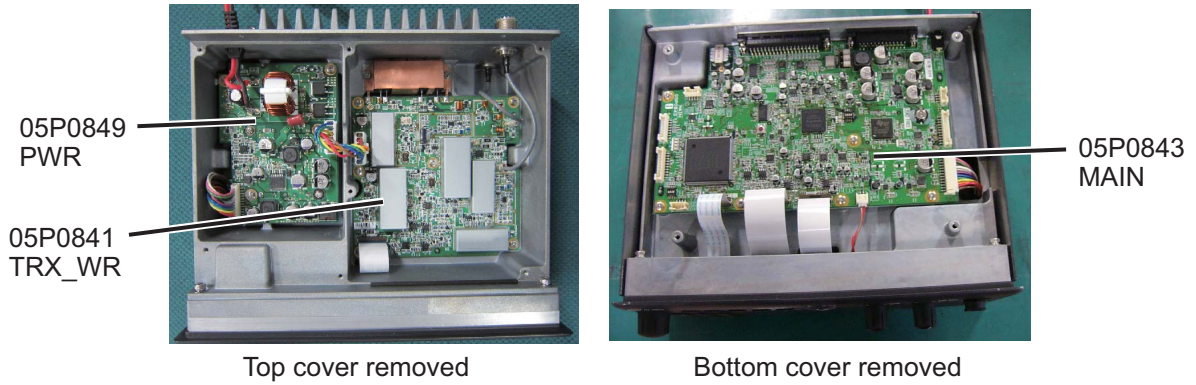

Handset HS-2003

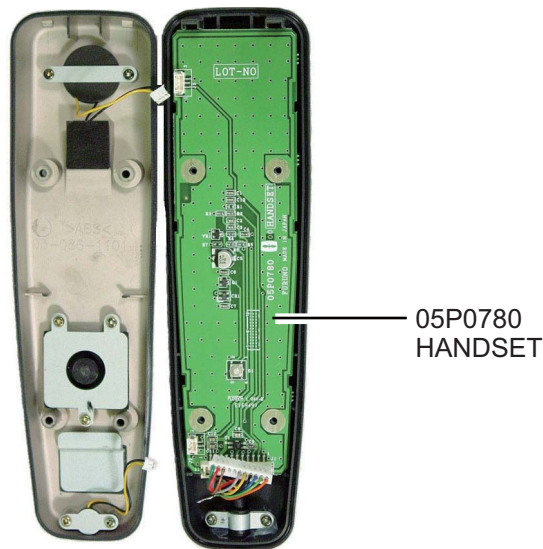

Remote station RB-8900 (HS-8900, HG-8900) / RB-8900-W (HS-8900-W, HG-8900-W)

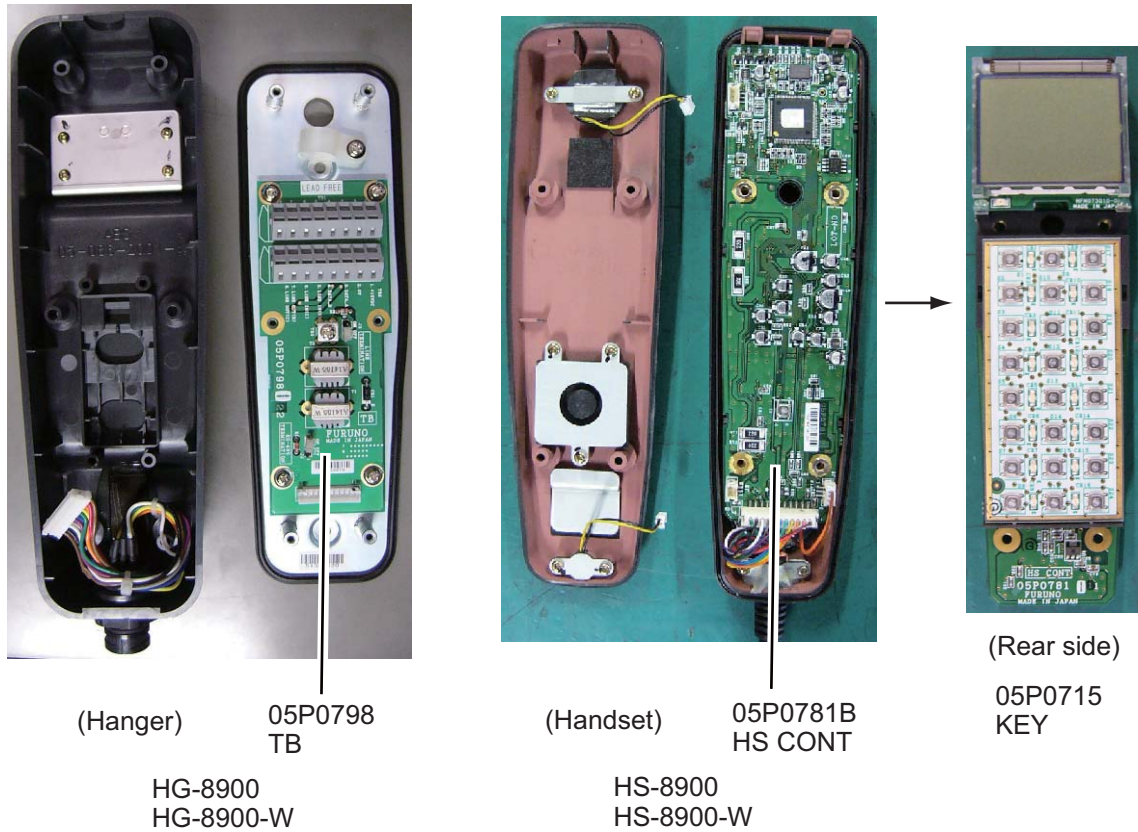

Junction box IF-8900

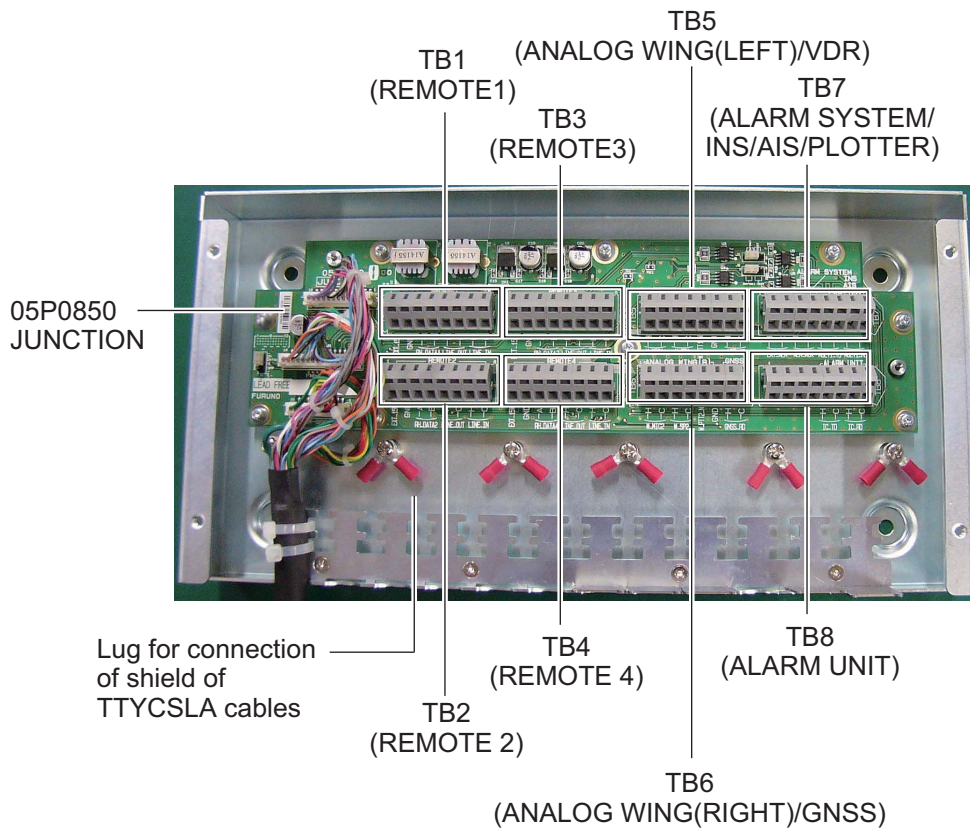

SPECIFICATIONS OF MARINE VHF RADIOTELEPHONE FM-8900S

1 GENERAL

- | | | |
|-----|----------------------|---|
| 1.1 | Number of channels | INTL: 57
USA: 50
Weather: 10
Canada: 57
INLAND-WA: 57
Private: 20
Memory CH: 50 |
| 1.2 | Frequency stability | Within ± 1.5 kHz |
| 1.3 | Communication system | Simplex/Semi-duplex |
| 1.4 | Class of emission | 16K0G3E (F3E) Voice, 16K0G2B (F2B) DSC |
| 1.5 | Antenna impedance | 50 ohms |
| 1.6 | Display | 4.3-inch color dot matrix LCD, 480 x 272 dots |
| 1.7 | Visible distance | 0.7 m nominal |

2 TRANSMITTER

- | | | |
|-----|---------------------|---------------------------------|
| 2.1 | Frequency range | 155.000 to 161.475 MHz |
| 2.2 | Output power | 25W max., 1W at power reduction |
| 2.3 | Frequency deviation | Within ± 5 kHz |

3 RECEIVER

- | | | |
|-----|------------------------|---|
| 3.1 | Frequency range | Simplex: 155.000 to 161.475 MHz
Semi-duplex: 159.600 to 164.200 MHz |
| 3.2 | Receiving system | Double superheterodyne |
| 3.3 | Intermediate frequency | 1st: 51.1375 MHz, 2nd: 62.5 kHz |
| 3.4 | Sensitivity | +6 dB μ V or less (20 dB SINAD) |
| 3.5 | Channel selectivity | 70 dB or more |
| 3.6 | Spurious response | 70 dB or more |
| 3.7 | AF output | Built-in speaker: 3W (4 ohms, THD: within 10%),
Handset earpiece: 2mW (150 ohms) |

4 DSC

- | | | |
|-----|-------------------------|--|
| 4.1 | Protocol | Rec. ITU-R M.541-9, M.493-13 (class A), M.689-2 |
| 4.2 | Baud rate | 1200 baud ± 30 ppm max. |
| 4.3 | Modulation | AFSK |
| 4.4 | Frequency of modulation | 1700 ± 400 Hz, Mark: 1300 Hz, Space: 2100 Hz |

5 CH70 WATCH KEEPING RECEIVER

- | | | |
|-----|---------------------|------------------------|
| 5.1 | Receiving frequency | 156.525 MHz |
| 5.2 | Receiving system | Double superheterodyne |

- 5.3 Intermediate frequency 1st: 38.3625 MHz, 2nd: 37.5 kHz
- 5.4 Sensitivity 0 dB μ V or less (SER<1%)
- 5.5 Channel selectivity 70 dB or more
- 5.6 Spurious response 70 dB or more

6 INTERFACE

- 6.1 Navigation data IEC61162-1 Ed.4(2010-11)
 - Input sentences GGA, GLL, GNS, RMC, VDM, ZDA
 - Output sentences DSC, DSE, TLL

7 POWER SUPPLY

- 7.1 Power voltage 24 VDC (-10%, +30%)
- 7.2 Power consumption (with all options)
 - Transmit 4.7A max. at 25W output
 - Receive 2.3A max. at 4W audio output
 - Waiting 1.3A max.

8 ENVIRONMENTAL CONDITION

- 8.1 Ambient temperature -15°C to +55°C
- 8.2 Relative humidity 93% or less at +40°C
- 8.3 Degree of protection
 - Transceiver unit (FM-8900S) IP20 (IP22: option)
 - Handset/Hanger (HS-2003/FP05-05510) IP24
 - Remote station RB-8900: IP22, RB-8900-W: IP56
 - Junction box IP20, IP22 (bulkhead mount, option)
- 8.4 Vibration IEC 60945 Ed.4

9 COATING COLOR

- 9.1 Transceiver unit N2.5 (fixed)
- 9.2 Remote station/ handset N2.5 (fixed)
- 9.3 VHF console 7.5BG7/2, 2.5G7/2 or specified

INDEX

A

- Abbreviation AP-13
- Address book
 - deleting.....5-11
 - editing.....5-10
 - list.....5-8
 - registration5-9
- Alarm lists5-21
- All ships message
 - receiving.....4-12
 - sending.....4-11
- Audio alarms2-2
- Auto ACK setting.....5-19

B

- Brilliance
 - remote handset6-3
 - transceiver unit.....1-3

C

- Channel region.....5-2
 - remote handset6-3
 - transceiver unit.....1-3
- Channel selection
 - remote handset6-4
 - transceiver unit.....1-4
- Contrast (remote handset)6-3
- Control description
 - remote handset6-1
 - transceiver unit.....1-1

D

- Daily test7-1
- Date and time setting5-5
- Digital interfaceAP-15
- Distress alert
 - canceling3-13
 - receiving.....3-4
 - sending.....3-1
- Distress relay
 - receiving.....3-13
 - sending.....3-10
- DSC messages2-1
- Dual channels (DW).....1-5

E

- Error message7-3
- External alarm setting5-7

G

- Group message
 - receiving.....4-7
 - sending.....4-6
- Group message preparation5-14

I

- Icon AP-14

Individual message

- receiving.....4-4
- sending.....4-1
- Individual message preparation5-13
- Intercom 1-8, 6-5

L

- Log file
 - deleting.....5-18
 - opening5-17

M

- Maintenance7-2
- Medical message
 - receiving.....4-19
 - sending.....4-18
- Memory channel calling up
 - remote handset6-4
 - transceiver unit.....5-2
- Memory configuration.....5-3
- MENU screen open/close5-1
- Menu tree AP-1

N

- Neutral message
 - receiving.....4-17
 - sending.....4-16

P

- Parst list AP-20
- Parst location AP-21
- Polling request message.....4-15
- Position message
 - receiving.....4-15
 - sending.....4-13
- Position setting.....5-4
- Power on/off
 - remote handset6-2
 - transceiver unit.....1-2
- Printing message5-4
- Priority1-7
- Propose channel5-20
- PSTN message
 - receiving.....4-10
 - sending.....4-8
- PSTN message preparation.....5-15

R

- Replay function1-12
- RT application setting.....5-8
- RT screen
 - remote handset6-2
 - transceiver unit.....1-2

S

- Scanning channels.....1-6
- Session1-9

Sound setting	
remote handset	6-6
transceiver unit	5-20
Speaker	
remote handset	6-5
transceiver unit	1-5
Special message	5-20
T	
Test call	7-4
Test message preparation	5-15
Timeout setting	5-5
Transmission	
remote handset	6-4
transceiver unit	1-4
Troubleshooting	7-2
V	
VHF channel lists	AP-3