

## 2.4 Processor Unit

The illustration below is the AC specification unit. The DC specification unit does not have the fuse.

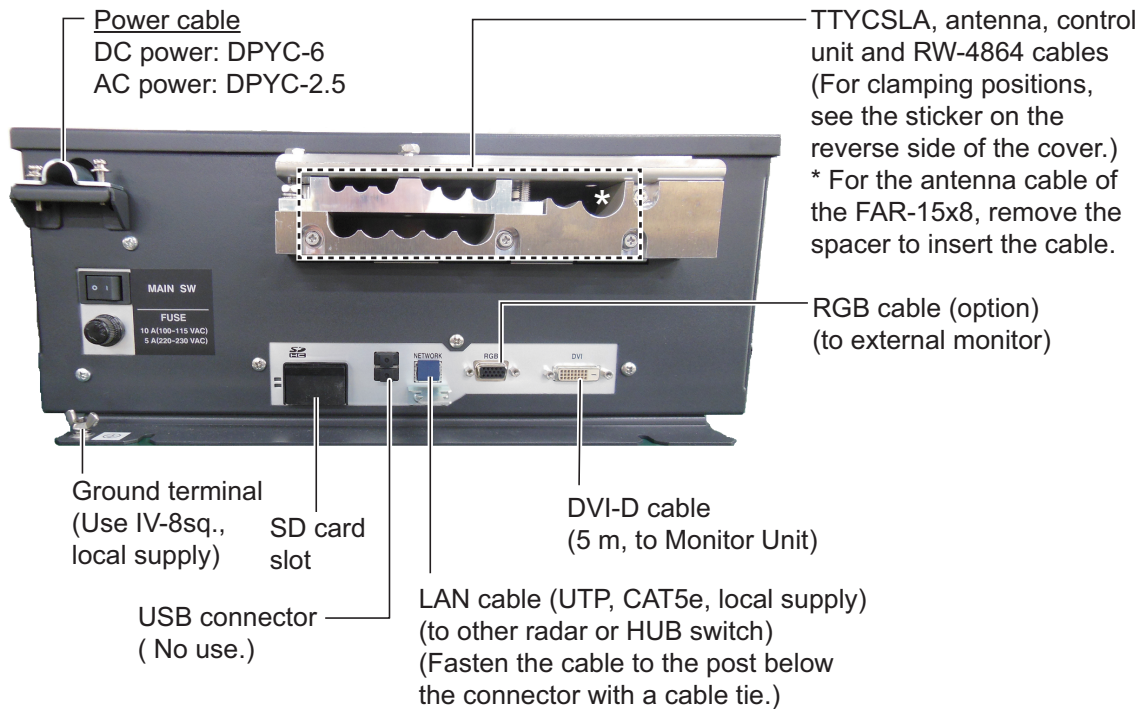

### 2.4.1 How to fabricate the power cable

1. Remove the armor of the cable by the amount shown in the figure below.
2. Remove the insulation of the cores 10 mm.
3. Fix crimp-on lugs (FV5.5-4, yellow, supplied) to the cores. Cover the end of the armor with vinyl tape. Lay the cable in the cable clamp on the cable entry side of the processor unit. Fasten the cable clamp.
4. Fasten the crimp-on lugs to the terminal block, referring to the interconnection diagram at the back of this manual.

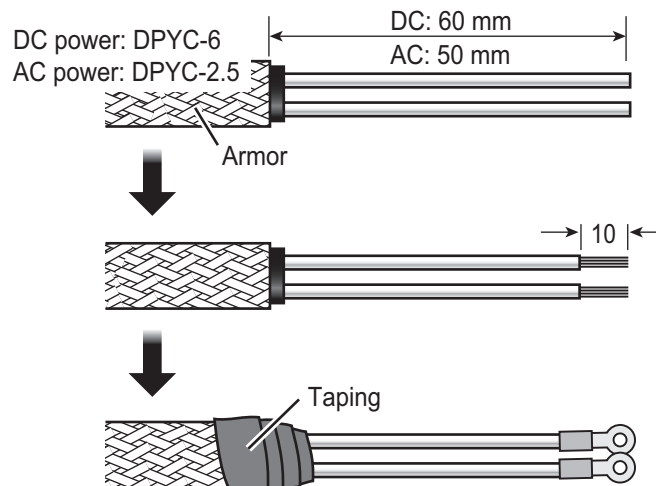

## 2.4.2 How to fabricate signal cable, cables from external equipment

### Signal cable for FAR-1518, FAR-1528

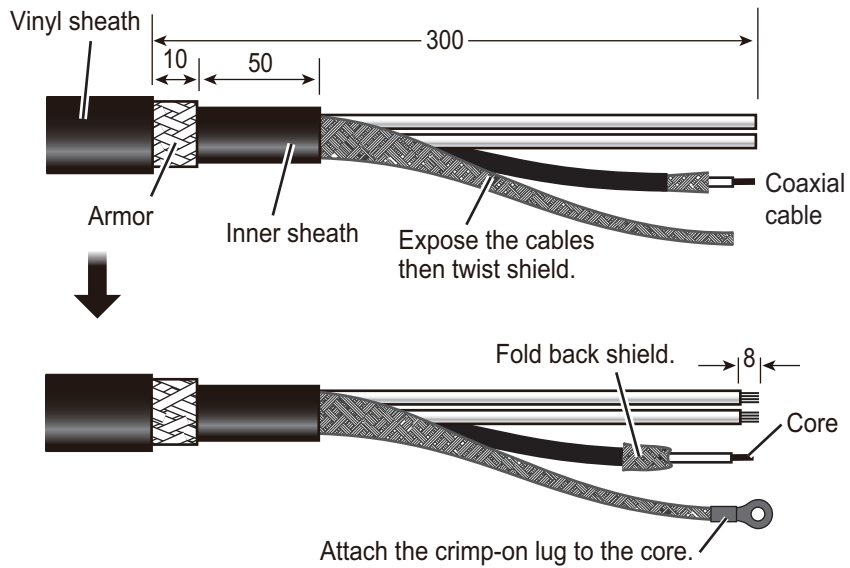

### Signal cable for FAR-1513, FAR-1523

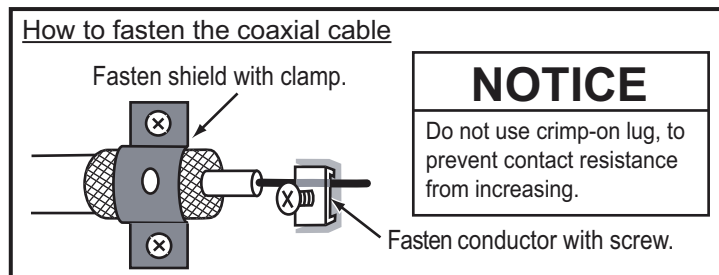
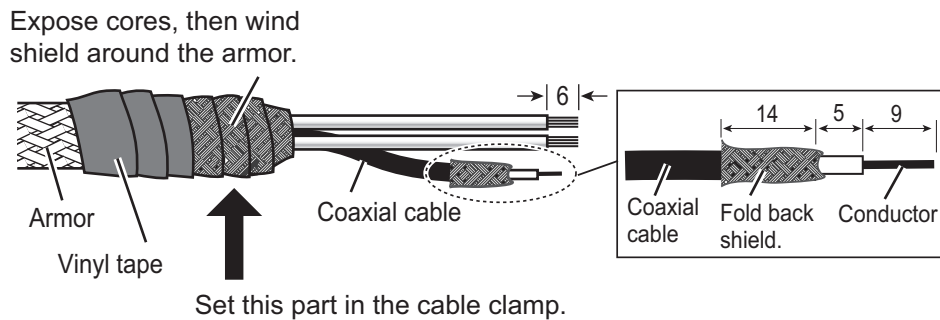

**TTYCS, TTYCSLA cables (for external equipment)**

For lengths, see the table on the next page.

*How to fabricate the TTYCS series cable*

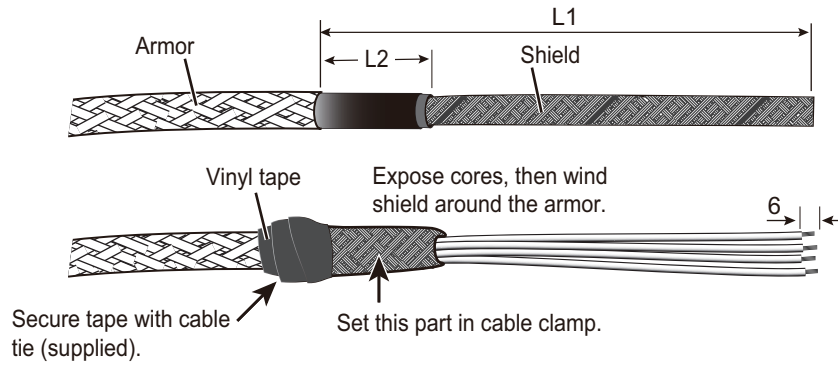

*How to fabricate the TTYCSLA series cable*

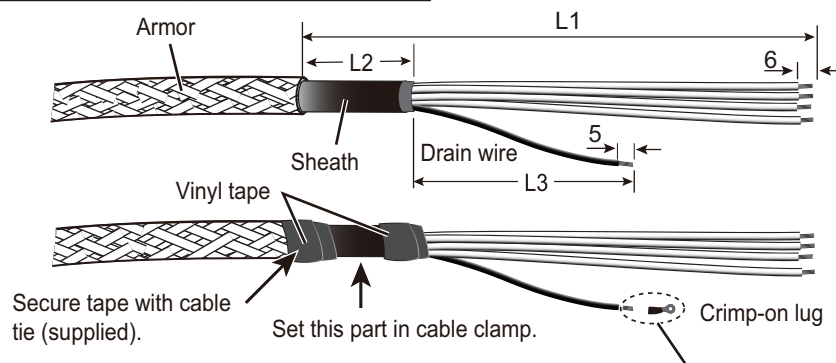

Pass the heat-resistant tubing (supplied) onto the drain wire. Attach a crimp-on lug (preattached to the processor unit) to the drain wire. Fasten the crimp-on lug to its original location.

**How to connect wires to WAGO connector**

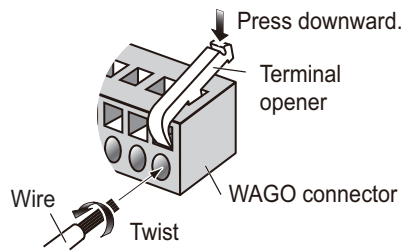

- <Procedure>
1. Twist the cores.
  2. Press the terminal opener downward.
  3. Insert the wire into the hole.
  4. Remove the terminal opener.
  5. Pull the wire to confirm that it is secure.

## 2. WIRING

### Connector, cable and lengths (L1, L2 and L3)

<b>Connector No.</b>	<b>Cable type</b>	<b>L1</b>	<b>L2</b>	<b>L3</b>
J613 (Ext. alarm contact signal)	TTYCSLA-7	300	70	150
J614 (HDG)	TTYCSLA-1Q	250	70	150
J615 (AIS)	TTYCSLA-4	200	70	200
J616 (GPS), J617 (LOG)	TTYCSLA-1	200	70	200
J618/J619/J620 (AMS/ECDIS/AD-10)	TTYCSLA-4	200	70	200

### **Signal cable RW-4864 (for sub display connection)**

To use the equipment as the main radar and connect a sub-radar, connect to J612 (SUB DISPLAY 1) or J611 (SUB DISPLAY 2), using the optional signal cable RW-4864. A maximum of two sub-radars can be connected.