

# *Installation Manual*

## **RIVER RADAR**

### **FR-1908V-BB**

---



<b>SAFETY INSTRUCTIONS .....</b>	<b>i</b>
<b>SYSTEM CONFIGURATION .....</b>	<b>iii</b>
<b>EQUIPMENT LISTS.....</b>	<b>iv</b>
<b>1. MOUNTING.....</b>	<b>1-1</b>
1.1 Antenna Unit .....	1-1
1.2 Processor Unit .....	1-5
1.3 Control Unit.....	1-7
1.4 Monitor Unit.....	1-7
<b>2. WIRING.....</b>	<b>2-1</b>
2.1 Antenna Unit .....	2-2
2.2 Processor Unit .....	2-6
<b>3. ADJUSTMENTS .....</b>	<b>3-1</b>
3.1 How to Open the Protected Menus.....	3-1
3.2 How to Set Alarms .....	3-2
3.3 How to Enter Your Ship's Characteristics .....	3-2
3.4 How to Adjust Sweep Timing .....	3-3
3.5 How to Adjust Video Level .....	3-4
3.6 Heading Alignment.....	3-4
3.7 How to Suppress Main Bang .....	3-5
3.8 How to Set the Transmission Stop Area .....	3-6
3.9 How to Set the Radar Antenna Position .....	3-6
3.10 How to Set the GPS Antenna Position.....	3-6
3.11 How to Adjust the ROT/Rudder/Autopilot Graph (Analog Input Only) .....	3-7
<b>APPENDIX 1 JIS CABLE GUIDE .....</b>	<b>AP-1</b>
<b>APPENDIX 2 INITIALIZE MENU TREE .....</b>	<b>AP-2</b>
<b>OUTLINE DRAWINGS .....</b>	<b>D-1</b>
<b>INTERCONNECTION DIAGRAMS.....</b>	<b>S-1</b>

This page is intentionally left blank.





# SAFETY INSTRUCTIONS

The installer of the equipment must read the safety instructions before attempting to install the equipment.

 <b>DANGER</b>	Indicates a potentially hazardous situation which, if not avoided, will result in death or serious injury.
 <b>WARNING</b>	Indicates a potentially hazardous situation which, if not avoided, could result in death or serious injury.
 <b>CAUTION</b>	Indicates a potentially hazardous situation which, if not avoided, could result in minor or moderate injury.

 Warning, Caution	 Prohibitive Action	 Mandatory Action
--	--	--

 <b>DANGER</b>	
	<p>Wear a safety belt and hard hat when working on the antenna unit.</p> <p>Serious injury or death can result if someone falls from the radar antenna mast.</p>

 **WARNING**



Do not open the equipment unless totally familiar with electrical circuits and service manual.

**ELECTRICAL SHOCK HAZARD**

Only qualified personnel should work inside the equipment.

---

Construct a suitable service platform from which to install the antenna unit.

Serious injury or death can result if someone falls from the radar antenna mast.

---

Turn off the power at the mains switchboard before beginning the installation.

Fire, electrical shock or serious injury can result if the power is left on or is applied while the equipment is being installed.

---

Be sure that the power supply is compatible with the voltage rating of the equipment.  
Connection of an incorrect power supply can cause fire or damage the equipment.

---

Use only the specified power cable.  
Fire or damage to the equipment can result if a different cable is used.

---

Use a disconnecting device (ex. breaker) to connect this equipment to the mains switchboard.

 **WARNING**

Do not install the monitor unit, processor unit or control unit where they may get wet from rain or water splash.

Water in the units can result in fire, electrical shock, or damage the equipment.

---



Ground the equipment to prevent electrical shock and mutual interference.

 **CAUTION**

Observe the following compass safe distances to prevent deviation of a magnetic compass:

	Standard compass	Steering compass
Antenna Unit	1.35 m	0.85 m
Processor Unit	0.70 m	0.40 m
Control Unit	0.60 m	0.35 m

# SYSTEM CONFIGURATION

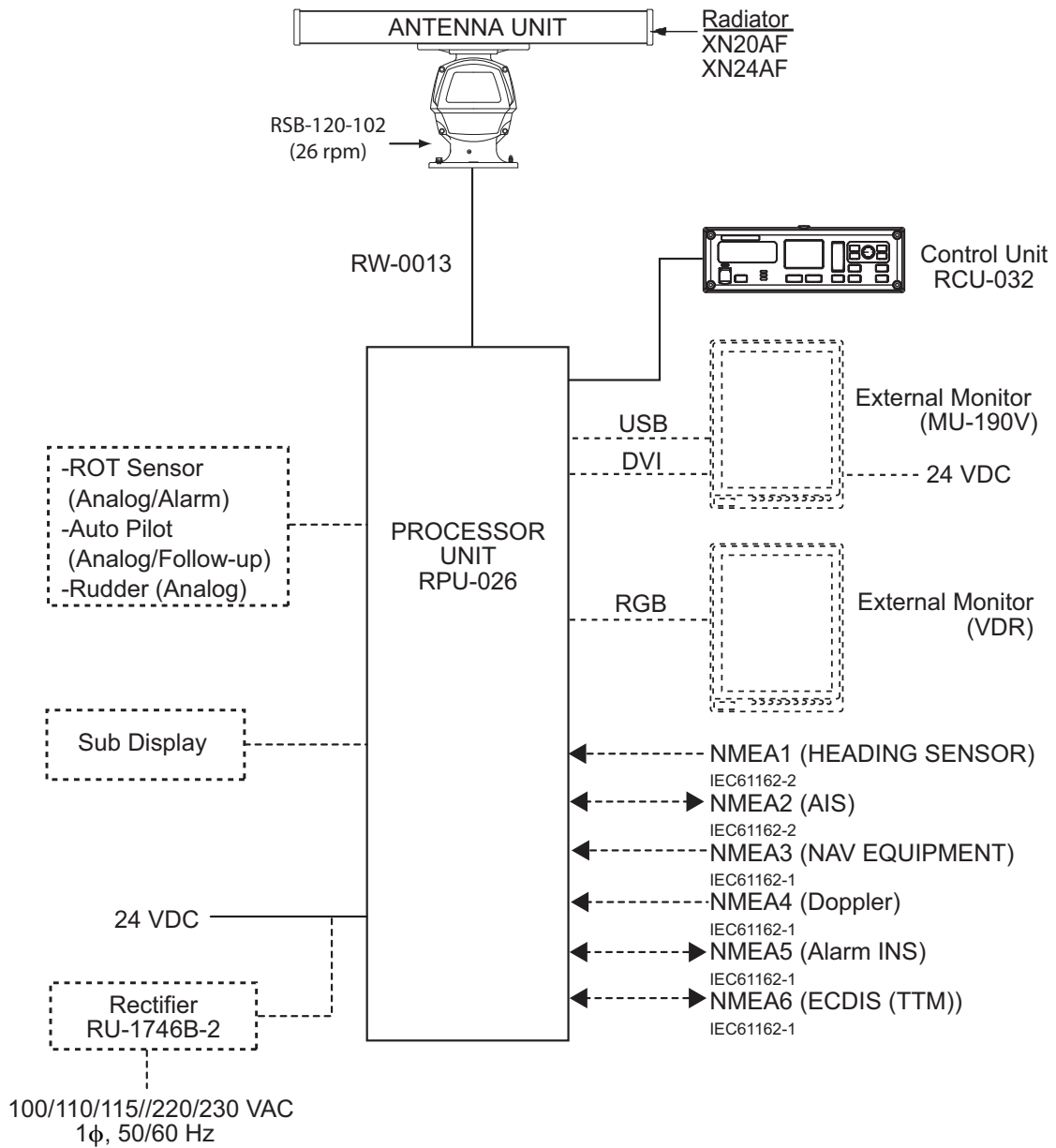

### Category of Units

Antenna Unit: Exposed to the weather

All other units: Protected from the weather

# EQUIPMENT LISTS

---

## Standard Supply

Name	Type	Code No.	Qty	Remarks
Antenna Unit	XN20AF-RSB-120-102	-	1	2040 mm, 26 rpm
	XN24AF-RSB-120-102	-		2550 mm, 26 rpm
Processor Unit	RPU-026	-	1	
Control Unit	RCU-032	-	1	
Installation Materials	CP03-34401	001-194-530	1	For control unit
	CP03-34501	001-194-550	1	For processor unit
	CP03-33401	001-107-930	1	For antenna unit
	CP03-19101	008-487-130	1	For radiator
Spare Parts	SP03-17201	001-194-540	1	For processor unit
	SP03-12501	008-485-360	1	For antenna unit

## Optional Supply

Name	Type	Code No.	Qty	Remarks
Rectifier	RU-1746B-2	000-030-439	1	
Cable Assy	RNS-08-132	000-174-105	1	USB for LCD brilliance

# 1. MOUNTING

---

## NOTICE

Do not apply paint, anti-corrosive sealant or contact spray to coating or plastic parts of the equipment.

Those items contain organic solvents that can damage coating and plastic parts, especially plastic connectors.

## 1.1 Antenna Unit

### 1.1.1 Mounting considerations

- The antenna unit is generally installed either on top of the wheelhouse or on the radar mast, on a suitable platform. Locate the antenna unit in an elevated position to permit maximum target visibility.
- No funnel, mast or derrick should be within the vertical beamwidth of the antenna in the bow direction, especially zero degrees  $\pm 5^\circ$ , to prevent blind sectors and false echoes on the radar picture.
- It is rarely possible to place the antenna unit where a completely clear view in all directions is available. Thus, you should determine the angular width and relative bearing of any shadow sectors for their influence on the radar at the first opportunity after fitting.
- Locate the antenna of a direction finder clear of the antenna unit to prevent interference to the direction finder. A separation of more than two meters is recommended.
- To lessen the chance of picking up electrical interference, avoid where possible routing the signal cable near other onboard electrical equipment. Also avoid running the cable in parallel with a power cable.
- A magnetic compass will be affected if placed too close to the antenna unit. Observe the compass safe distances shown on page ii to prevent deviation of a magnetic compass.
- Do not paint the radiator aperture to ensure proper emission of the radar waves.
- The antenna base is made of cast aluminum. To prevent electrolytic corrosion of the antenna base, use the seal washers and corrosion-proof rubber mat and ground the unit with the ground wire (supplied).
- Deposits and fumes from a funnel or other exhaust vent can adversely affect the aerial performance and hot gases may distort the radiator portion. The antenna unit must not be mounted where the temperature is more than  $55^\circ\text{C}$ .
- Leave sufficient space around the unit for maintenance and servicing. See the antenna unit outline drawing for recommended maintenance space.

## 1. MOUNTING

### 1.1.2 How to assemble the antenna unit

The antenna unit consists of the antenna radiator and the antenna unit chassis, and they are packed separately. Fasten the antenna radiator to the antenna unit chassis as below:

1. Attach two guide pins to the underside of the antenna radiator.
2. Remove a waveguide cap from the radiator bracket. The cap may be discarded.
3. Coat the waveguide flange with anticorrosive sealant as shown below.

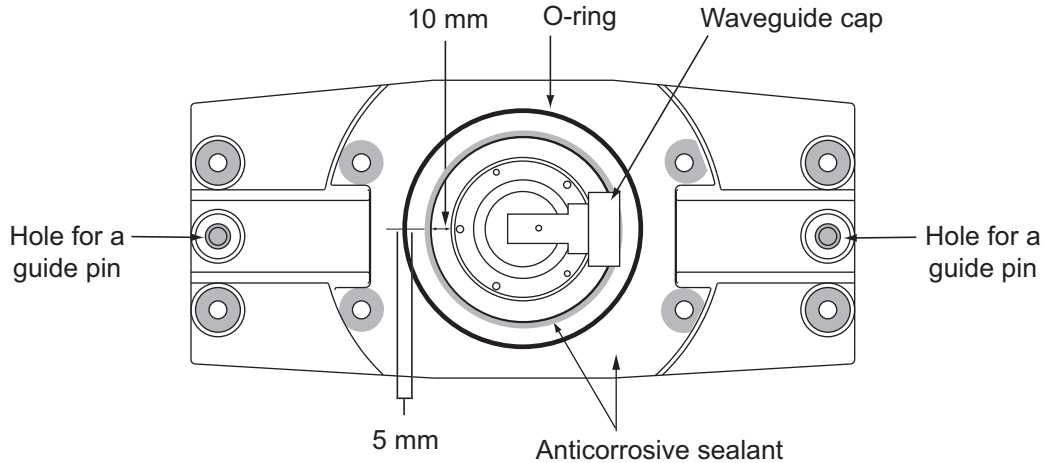

4. Coat fixing holes for the antenna radiator with anticorrosive sealant.
5. Grease the O-ring and set it to the O-ring groove of the radiator flange.
6. Set the antenna radiator to the radiator bracket.
7. Coat hex bolts M8x40 with anticorrosive sealant and use them to loosely fasten the antenna radiator to the antenna unit chassis.
8. Remove two guide pins (inserted at step 1), and then tighten fixing bolts.

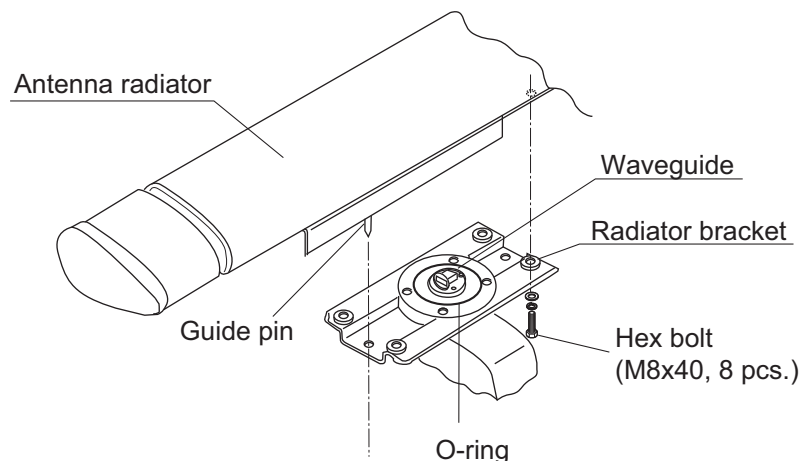
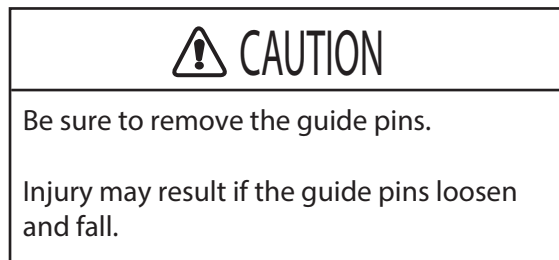



### 1.1.3 How to fasten the antenna unit to the mounting platform

The antenna unit may be assembled before hoisting it to the mounting platform. However, do not lift the antenna unit by the radiator. Always hold the unit by its housing. When using a crane or hoist, use the hoist rings which should be fastened to the bolt fixing covers of the antenna housing.

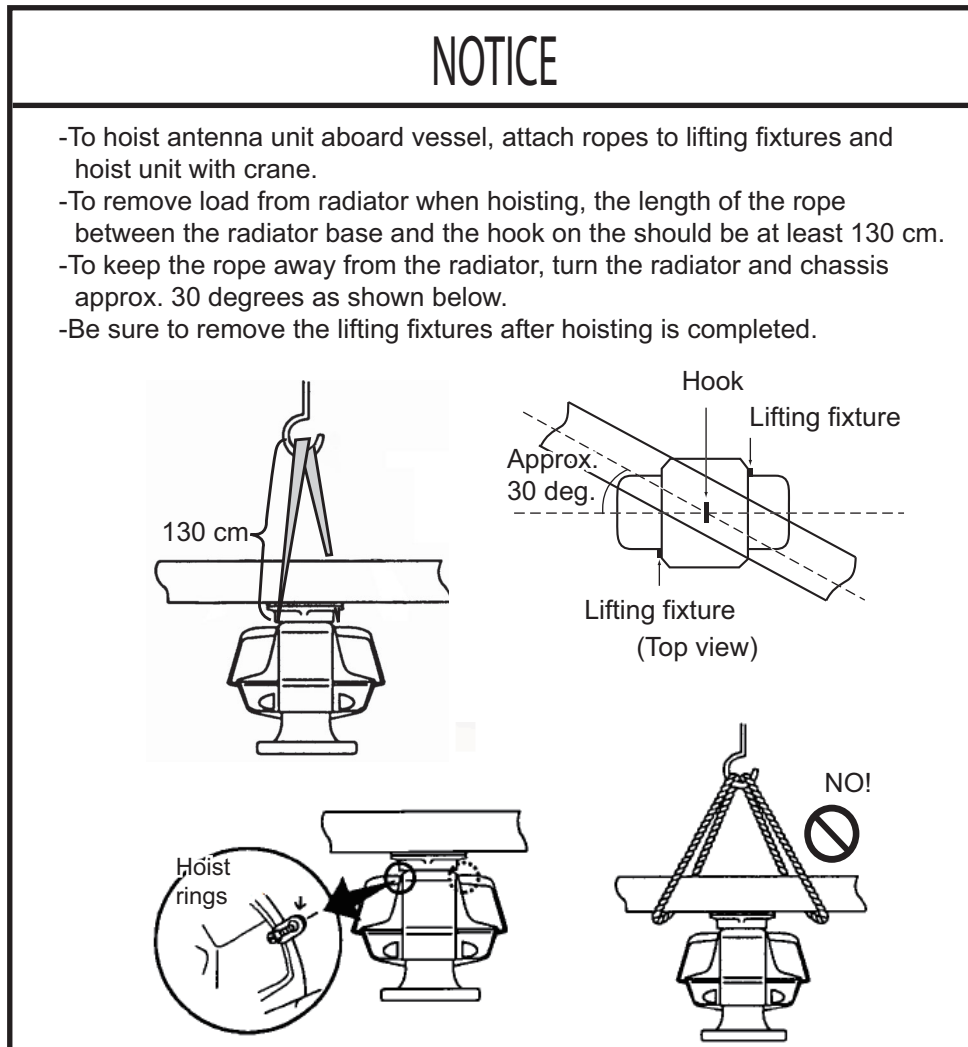

1. Construct a suitable mounting platform referring to the outline drawing at the end of this manual.
2. Drill four mounting holes of 15 mm diameter and one cable entry hole of about 50 mm diameter in the mounting platform.
3. Lay the rubber mat (supplied) on the mounting platform.
4. Place the antenna unit on the rubber mat, orienting the unit so the bow mark on its base faces the ship's bow.

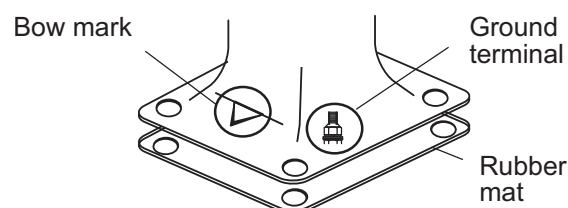

# 1. MOUNTING

5. Fasten the antenna unit to the mounting platform with M12x60 hex. bolts, nuts, flat washers and seal washers.
6. Use hex. bolt (M6x25), nut (M6) and flat washers (M6) to establish the ground system on the mounting platform as shown below. The location should be within 340 mm of the ground terminal on the antenna unit. Connect the ground wire (RW-4747, 340 mm, supplied) between the grounding point and the ground terminal on the antenna unit. Coat the entire ground system with silicone sealant (supplied).

Antenna unit fixing bolt  
(Sectional view)

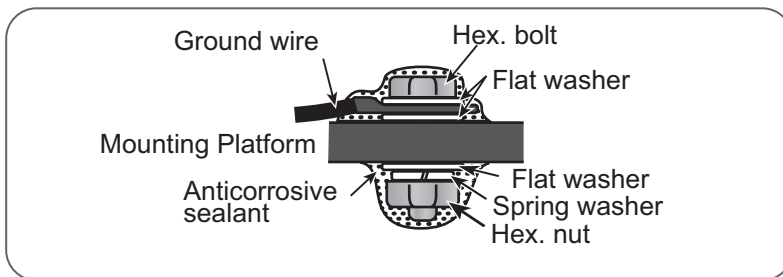
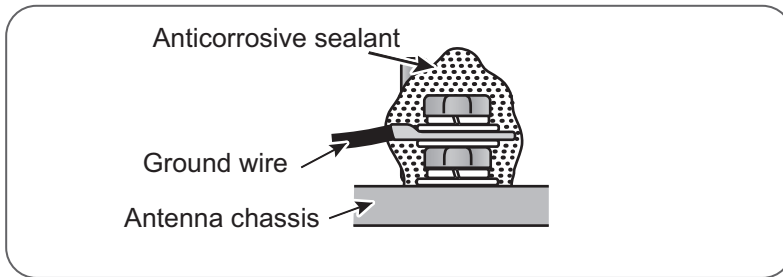
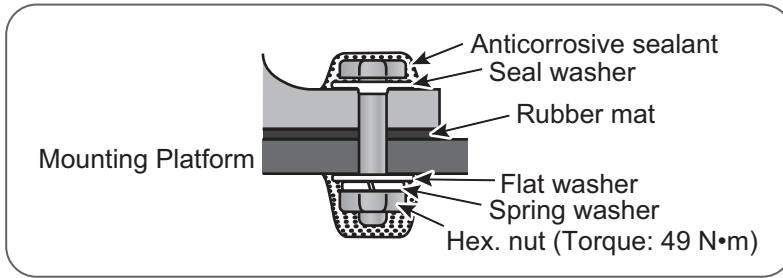

or

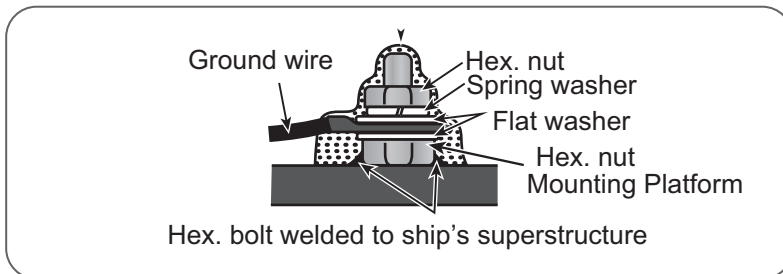

Coat with marine sealant.

The ground point must be within 300 mm from the ground terminal on the antenna unit.

7. Confirm that the hoist rings are removed.

## 1.2 Processor Unit

### 1.2.1 Mounting consideration

The processor unit can be mounted on a desktop or bulkhead. When selecting a mounting location, keep in mind the following points:

- Locate the unit out of direct sunlight and away from heat sources because of heat that can build up inside the cabinet.
- Locate the equipment away from places subject to water splash and rain.
- Select a mounting location considering the length of the cables connected.
- Leave sufficient space on the sides and rear of the unit to facilitate maintenance. (See the outline drawing at the back of this manual.)
- A magnetic compass will be affected if placed too close to the processor unit. Observe the compass safe distances shown on page ii to prevent deviation of a magnetic compass.

### 1.2.2 How to mount the processor unit

#### Desktop installation

Fasten the unit with four bolts (M5, supplied) or self-tapping screws (5x20).

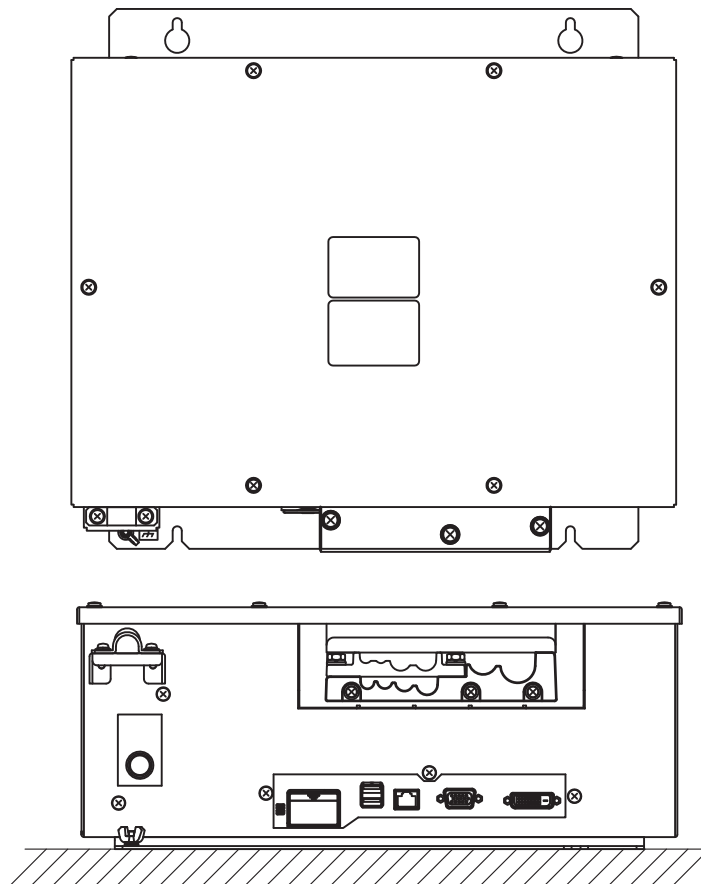

## 1. MOUNTING

### **Bulkhead installation**

**Note:** The cable entry side should be downward when the processor unit is mounted on the bulkhead.

1. Mark location for four self-tapping screws if screws will be used.
2. Insert four bolts (M5, supplied) or self-tapping screws (5x20), leaving approx. 5 mm of the bolts (screws) exposed.
3. Hang the processor unit on the four bolts (screws) inserted at step 2.
4. Tighten all bolts (screws).

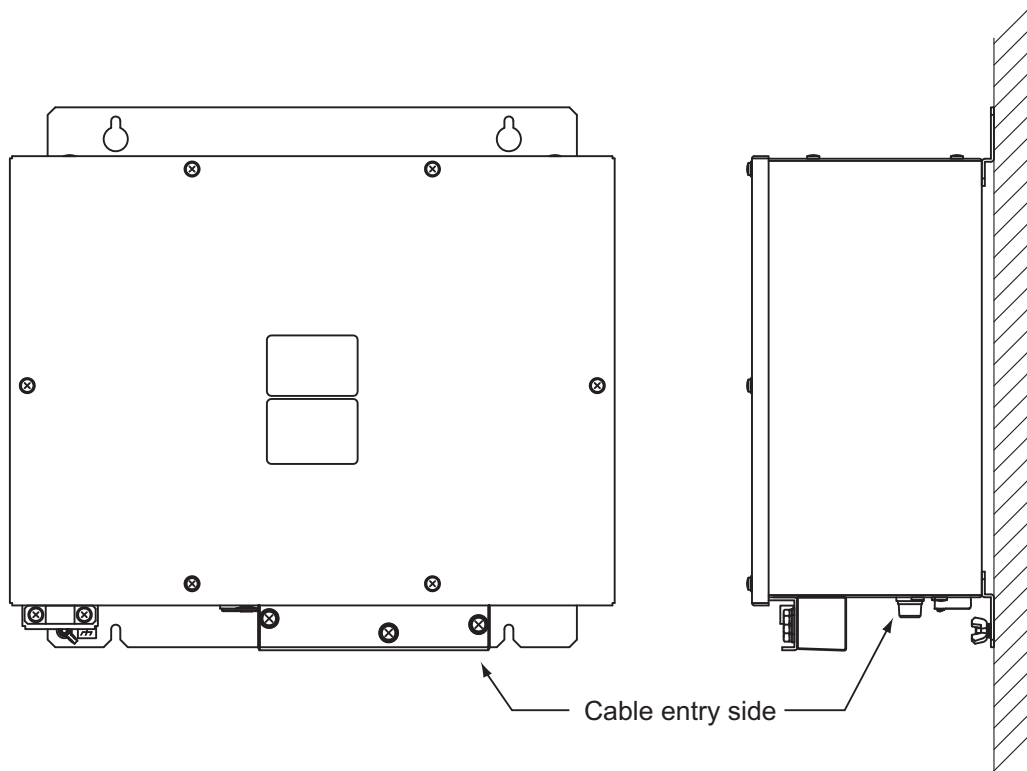

## 1.3 Control Unit

The control unit can be installed on a desktop. The control unit should be mounted within five meters from the processor unit since the length of the cable connecting them is five meters.

1. Drill four mounting holes of 5 mm diameter referring to the outline drawing at the back of this manual.
2. Fix the control unit with four self-tapping screws ( $\phi 4$ ) from the top of the control unit. The M4 screws with a sufficient length for the thickness of the tabletop should be provided locally.
3. Attach four cosmetic caps to the fixing holes on the control unit.

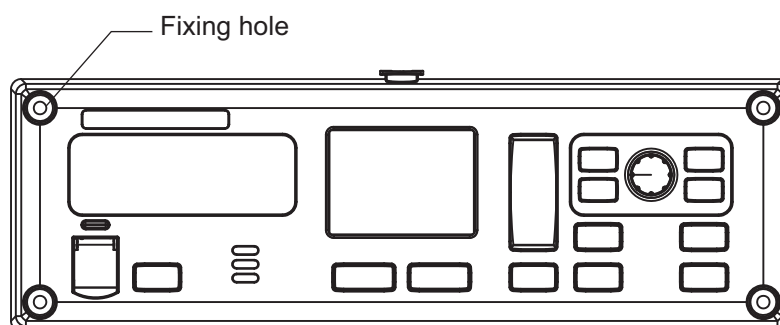

## 1.4 Monitor Unit

The monitor unit is required the vertical type indication because of output image signal displayed on the longitudinal direction. And also, is designed assuming being connected the MU-190V (Option). When using a monitor except MU-190V, be careful about the next explanation.

- Brightness cannot be adjusted via a radar menu and the control unit with the general commercial monitors. Therefore, adjust brightness with functions of the monitor itself.
- The indication of the FR-1908V-BB cannot be flipped upside down according to the monitor direction. For the correct indication, install the horizontal type monitor in the state that turned 90 degrees clockwise. And then, confirm that the monitor can be fixed in this direction beforehand.
- When using the turned horizontal monitor, the viewing angle of the right and left (top and bottom direction in the original state) may be different. Therefore, a problem such as a echo color and the vanity echo being different in right and left may occur.

## 1. MOUNTING

This page is intentionally left blank.

# 2. WIRING

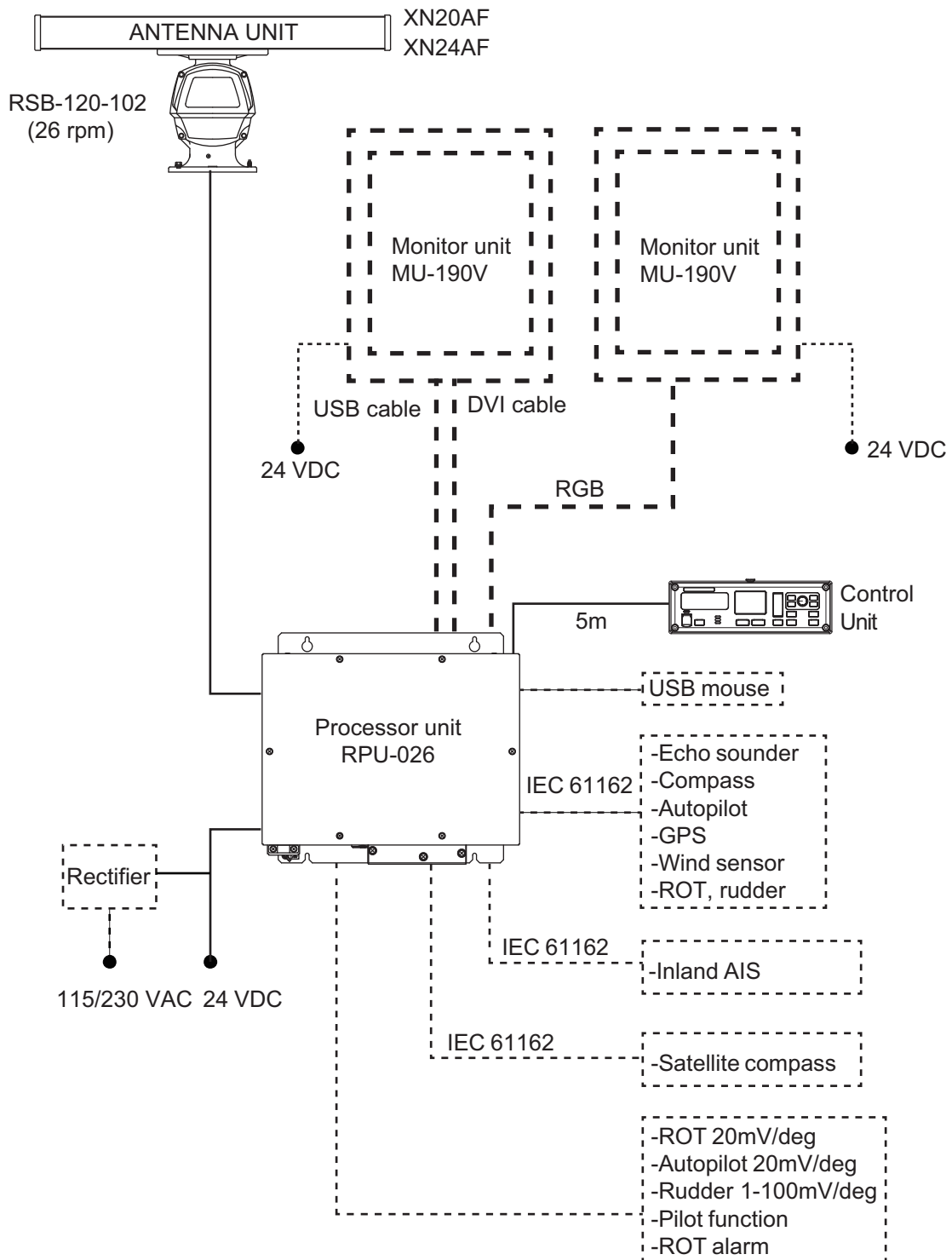

## 2.1 Antenna Unit

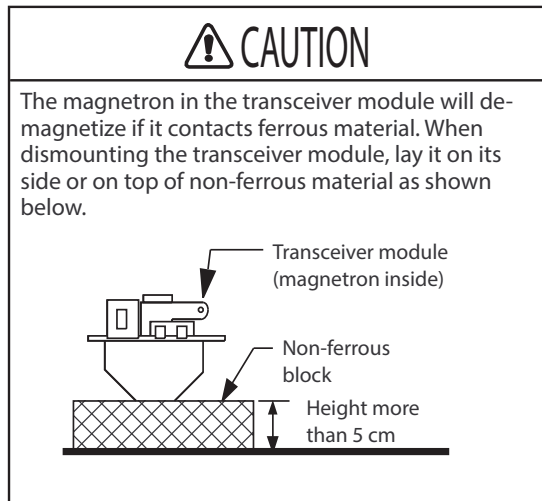

1. Open the antenna cover.
2. Disconnect plugs P821, P822, P801 and P802.

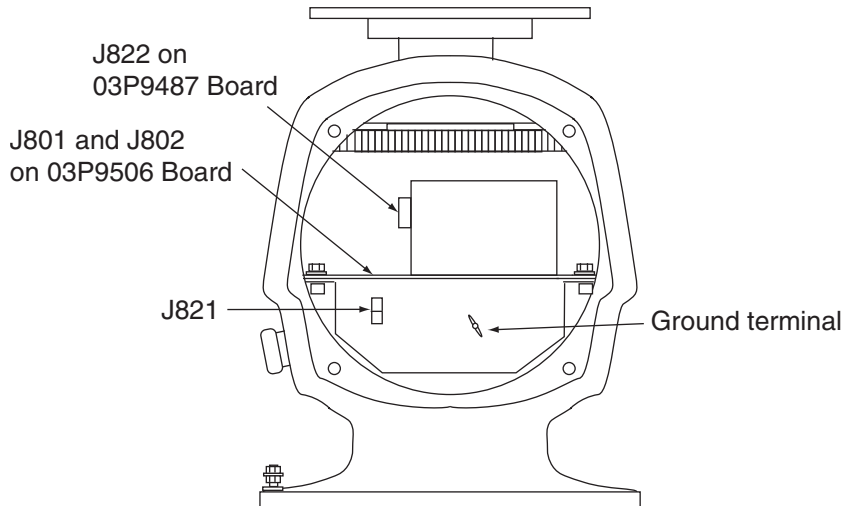

3. Unfasten the transceiver module (two bolts). Remove the transceiver module.
4. Unfasten four fixing bolts on the cable gland at the base of the antenna unit. Remove clamping ring, rubber gasket and washers.
5. Pass the signal cable through the cable entry hole in the antenna unit mounting platform. Trim the cable to 800 mm length from the cable gland.
6. Slide two washers, rubber gasket, washer and clamping ring onto the cable in that order.

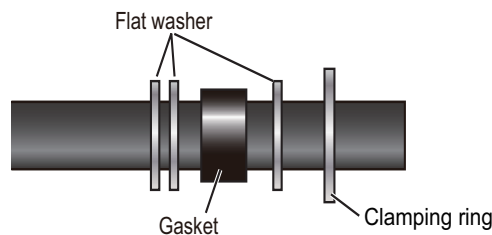

7. Fabricate the signal cable as shown in below.
  - 1) Remove the vinyl sheath for a length by 460 mm.



- 2) Unravel the outer shield to expose the cores in the outer layer. Then, expose the cores in the inner layer. Label all inner cores to aid in identification.
  - 3) Trim each core (except coaxial wire) considering its location on the terminal board.
  - 4) Trim the inner and outer shields leaving 510 mm each. Twist shields together and attach crimp-on lug FV5.5-4 (yellow,  $\phi 4$ .)
  - 5) Remove insulation of each core approx. 8 mm.
8. Fabricate the coaxial cable.

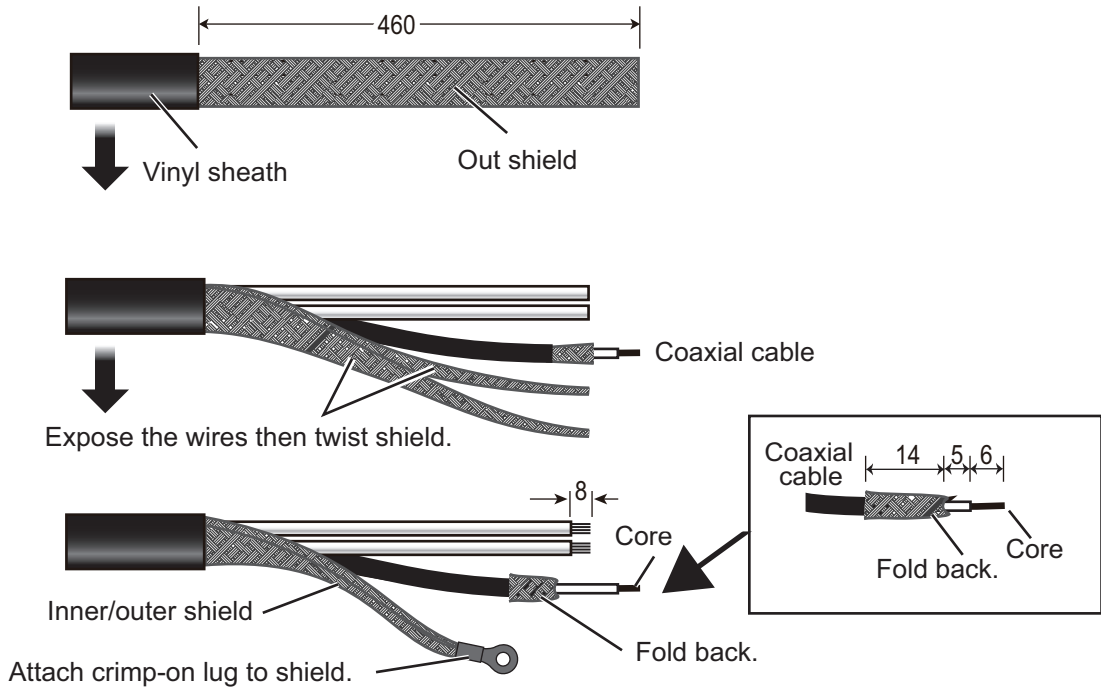

9. Pass the shield between the clamping ring and the washer as shown below. Fasten the clamping ring with the screws.

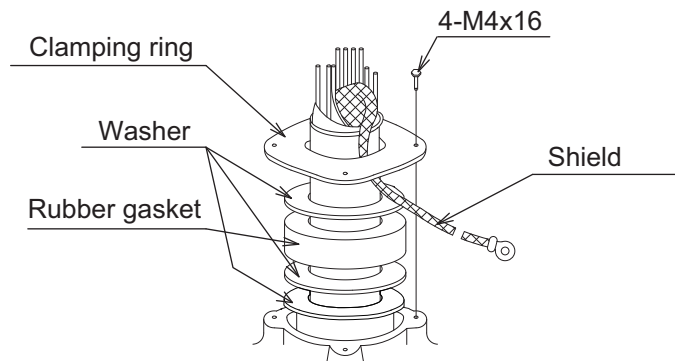

2. WIRING

10. Connect the signal cable to the terminal board TB801, TB802 and TB803 on the 03P9488 board, referring to the interconnection diagram.

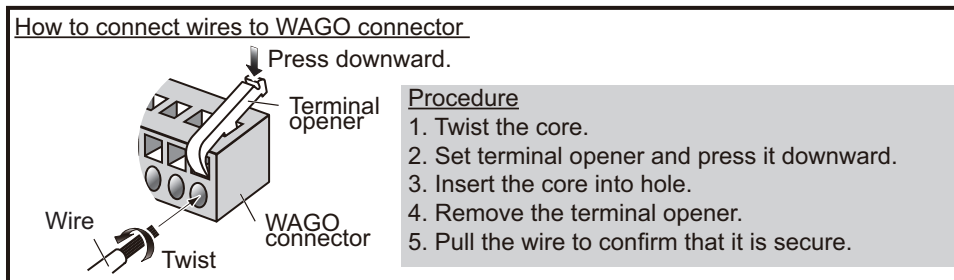
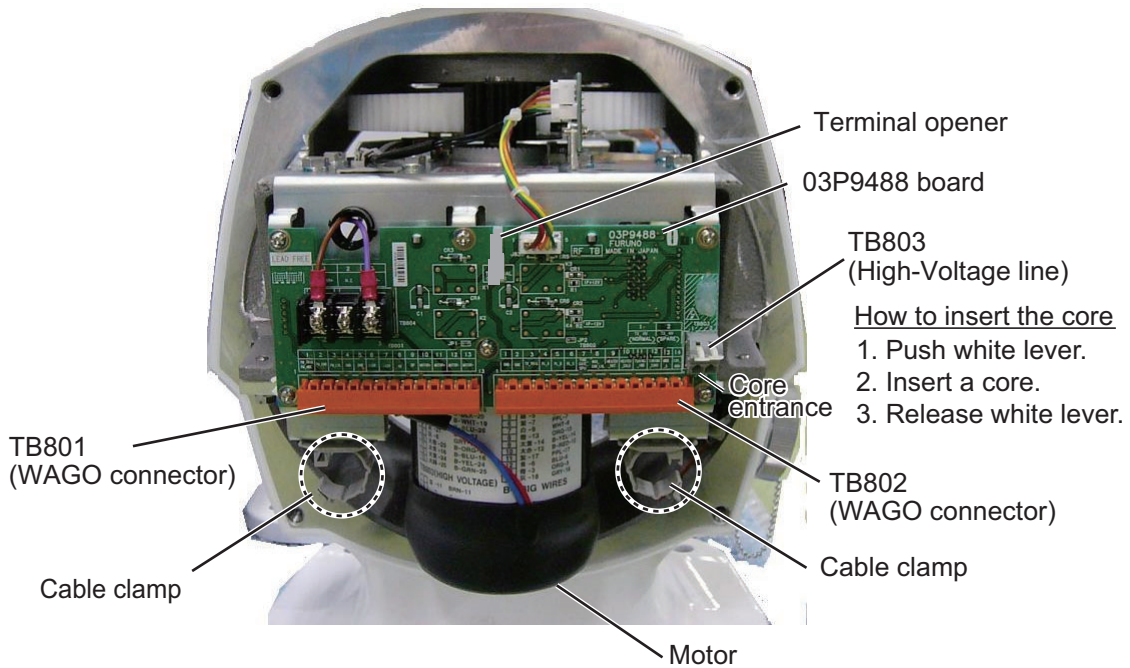

11. Pass the coaxial cable under the transceiver fixing plate (arrow) and the clamp (dashed circle).

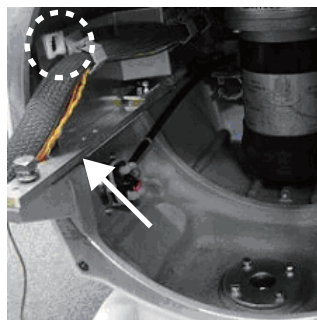

12. Detach the junction box from the transceiver unit.

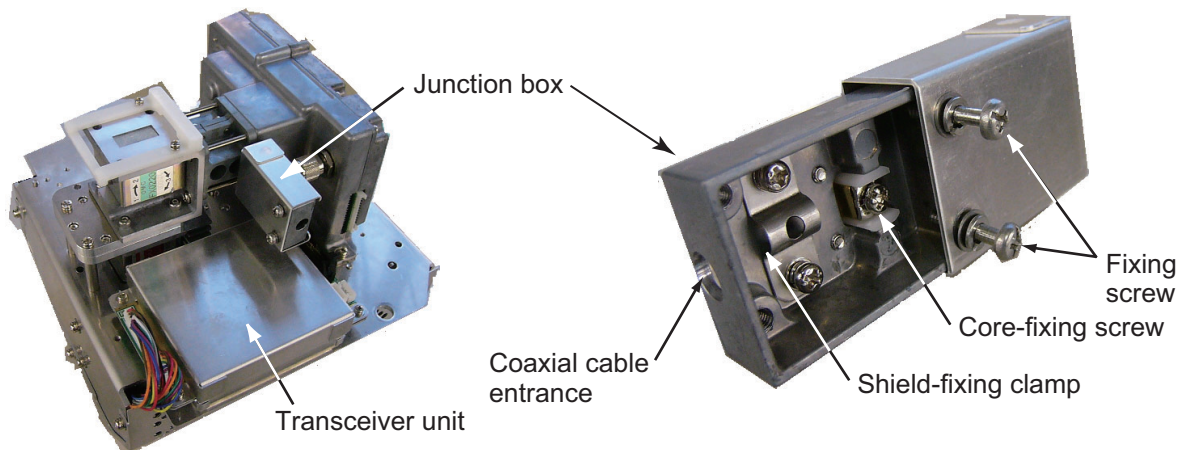

13. Loosen the two screws on the junction box, then slide the cover to open the box. Connect the coaxial cable as shown below.

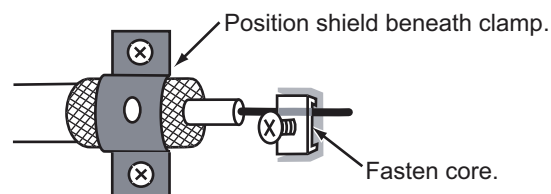

14. Close the junction box and tighten the screws. Reattach the box to the transceiver unit.
15. Reconnect the plugs disconnected at step 2.
16. Set the transceiver module to the antenna unit and push the module in until it stops. Tighten the fixing bolts. **Be sure to push in the transceiver unit until it stops. Failure to do so may cause microwave leakage.**
17. Fasten the shield wire to the wing nut on the transceiver module.
18. Confirm that all screws are tightened and all wiring is properly made. Confirm that the waterproofing gasket, bolts and tapping holes of the antenna unit are coated with silicone grease.
19. Close the antenna unit cover.

## 2.2 Processor Unit

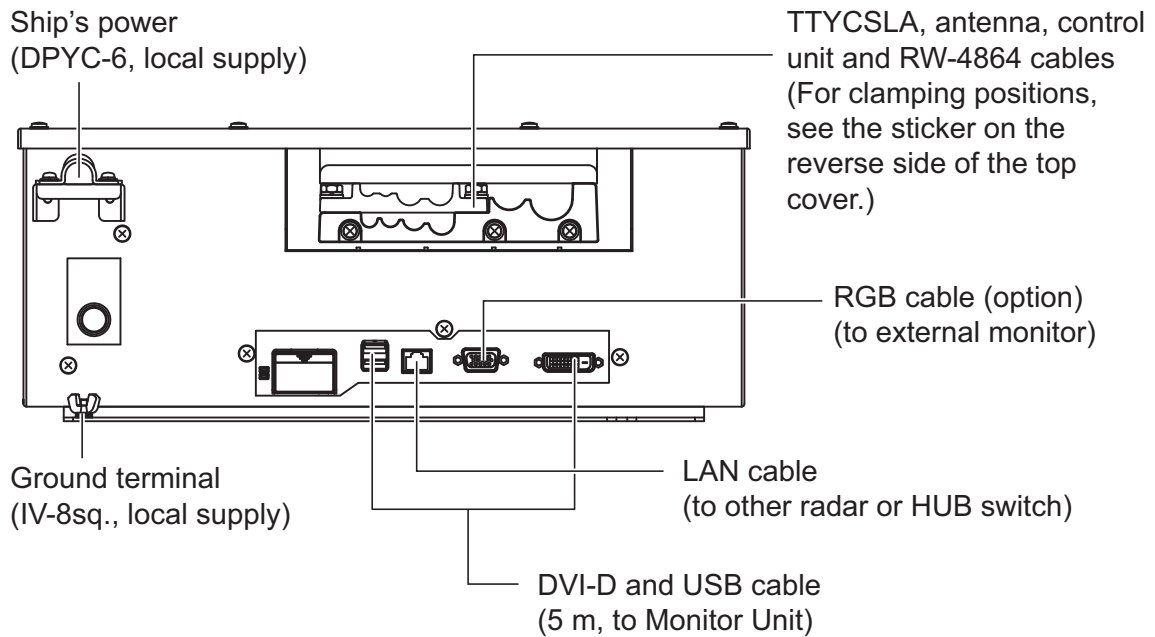

### How to fabricate the power cable

1. Remove the armor of the cable and the vinyl sheath by 60 mm.
2. Remove the vinyl sheath 40 mm.
3. Remove the insulation of the cores 10 mm. Fix crimp-on lugs (FV5.5-4, yellow, supplied) to the cores.
4. Peel the paint of the armor 40 mm for to make ground connection.
5. Cover the end of the armor with vinyl tape. Lay the section where paint was peeled on the cable clamp on the cable entry side of the processor unit. Fasten the cable clamp.
6. Fasten the crimp-on lugs to the terminal block.

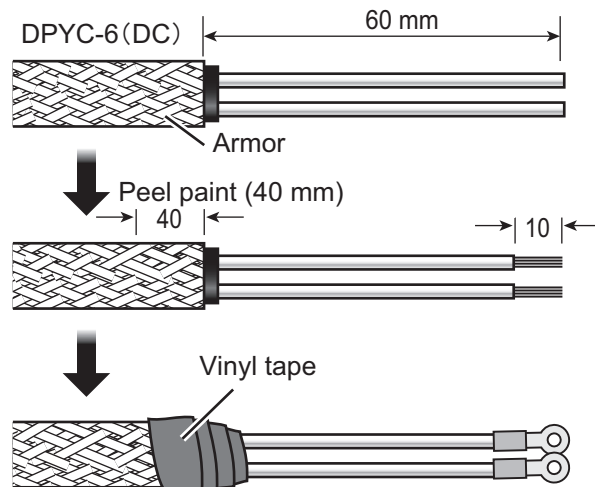

## How to connect cables inside the processor unit

Connect cables from the antenna unit and optional equipment are connected to the FRP\_TB board (03P9548), inside the processor unit. Open the cover of the processor unit to find the board.

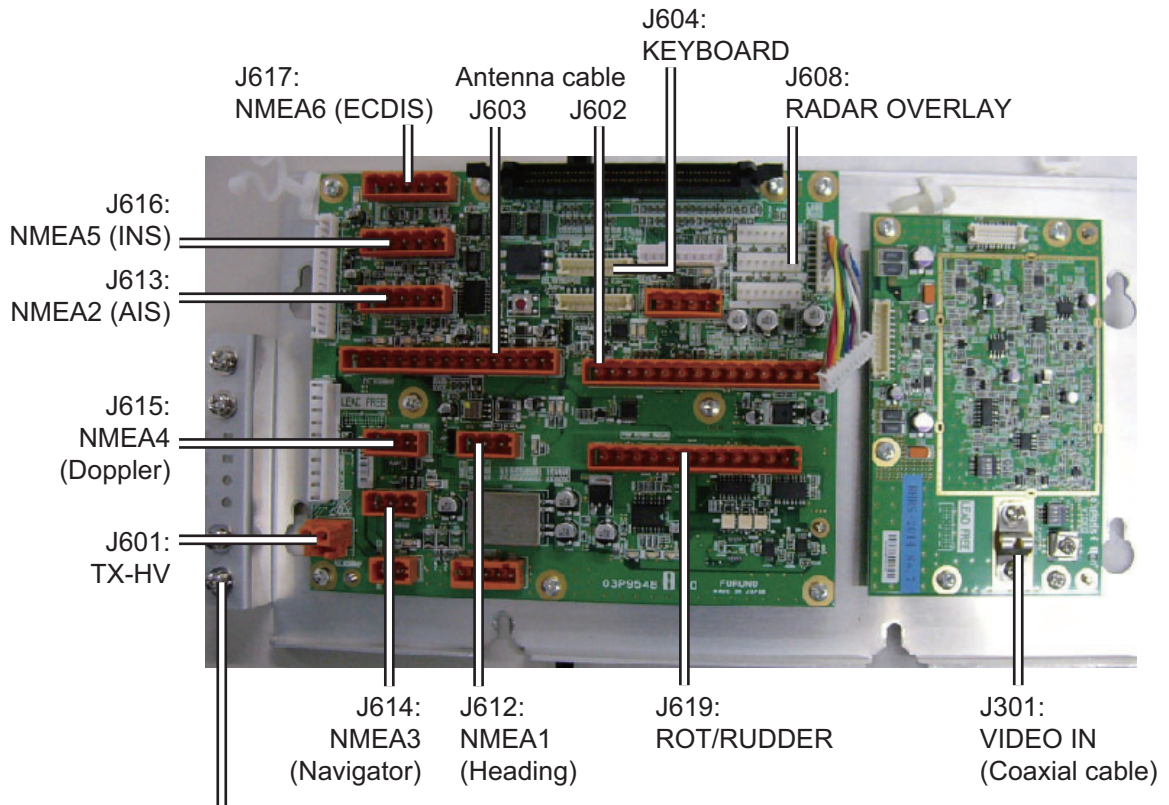

Attach the drain wires of the TTYCSLA cables to here.

## How to fabricate cables connected to the FRP\_TB board (03P9548)

### Signal cable RW-0013

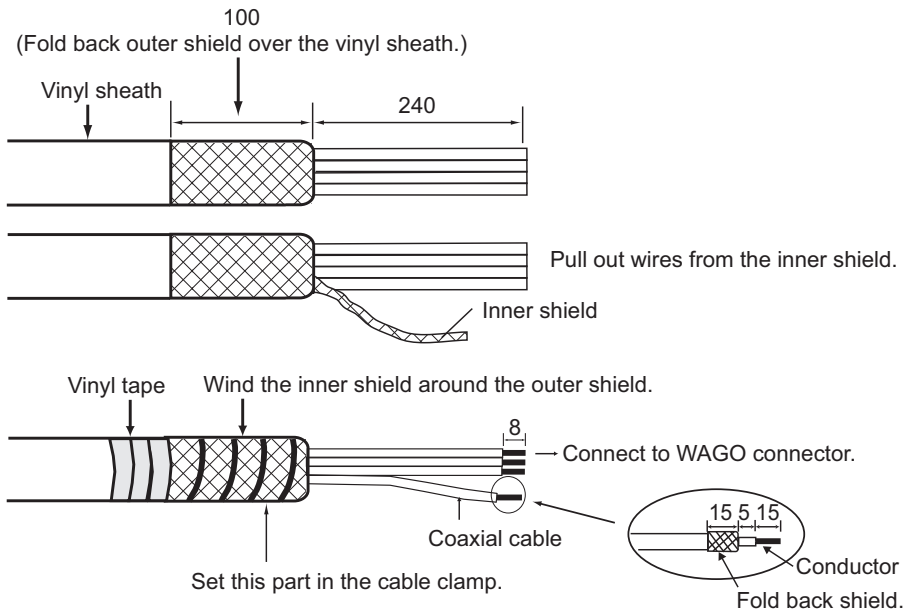

### TTYCSLA cables

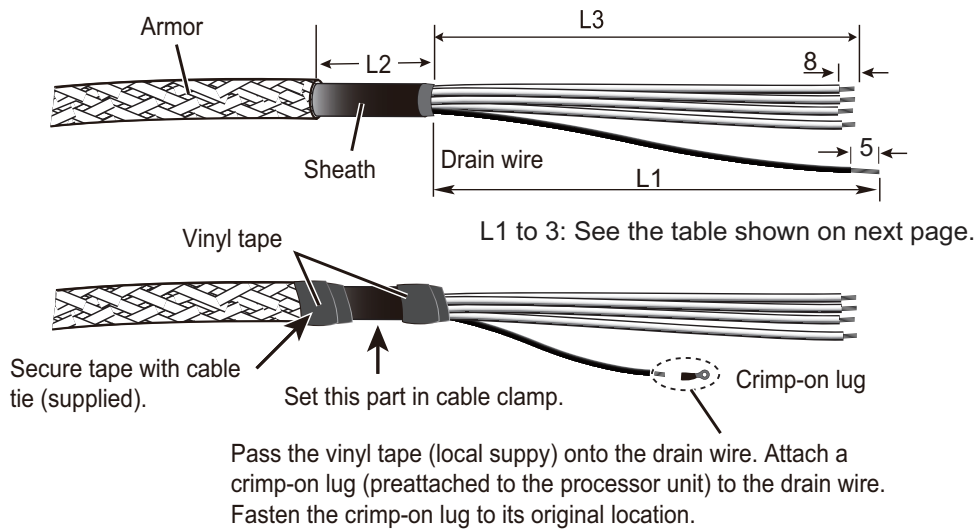

#### Cable lengths of L1, L2 and L3

Connector No.	Cable type	L1	L2	L3
J612 (NMEA1)	TTYCSLA-1T	120	60	80
J613 (NMEA2)	TTYCSLA-4	200	60	150
J614 (NMEA3)	TTYCSLA-1	120	60	100
J615 (NMEA4)	TTYCSLA-1	60	100	120
J616 (NMEA5)	TTYCSLA-4	250	80	200
J617 (NMEA6)	TTYCSLA-4	230	80	200
J619 (ROT/RUDDER)	TTYCSLA-7	200	60	120

## Replacement of boards

The following explanation is for the maintenance and trouble shooting. Therefore, it is not required at the installation.

### **SPU Board (03P9547)**

1. Unscrew six binding screws (M4) to unfasten the FRP\_TB Board base, then disconnect the ribbon cable from the board.
2. Unfasten five hex. bolts (M4) to remove the clamp panel.
3. Disconnect the VIDEO and power cables from the FRP\_TB Board.
4. Lift up the FRP\_TB Board base to unfasten five binding screws (M4) to remove the SPU Board.

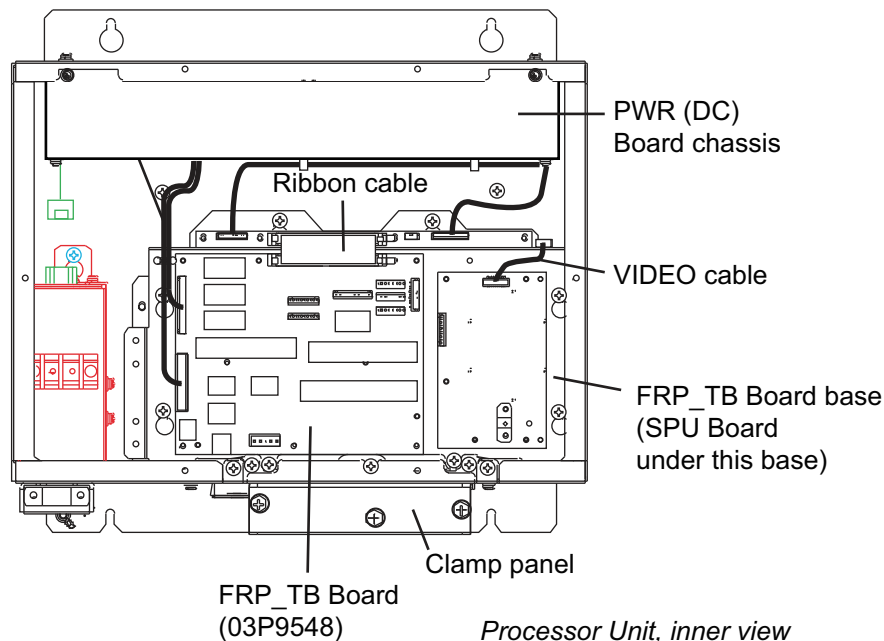

### **PWR (DC) Board (03P9497A)**

When it is difficult to dismount the PWR (DC) Board chassis from the processor unit because of the melted cooling sheet, screw a M4 x 8 (or more, local supply) screw into the hole shown below to push out the chassis.

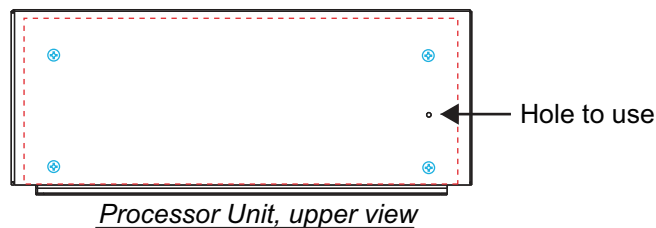

## 2. WIRING

This page is intentionally left blank.



# 3. ADJUSTMENTS

At the first power application after installation, open the protected menus to adjust the radar. Follow the procedures in this section, in the order shown, to complete the adjustment.

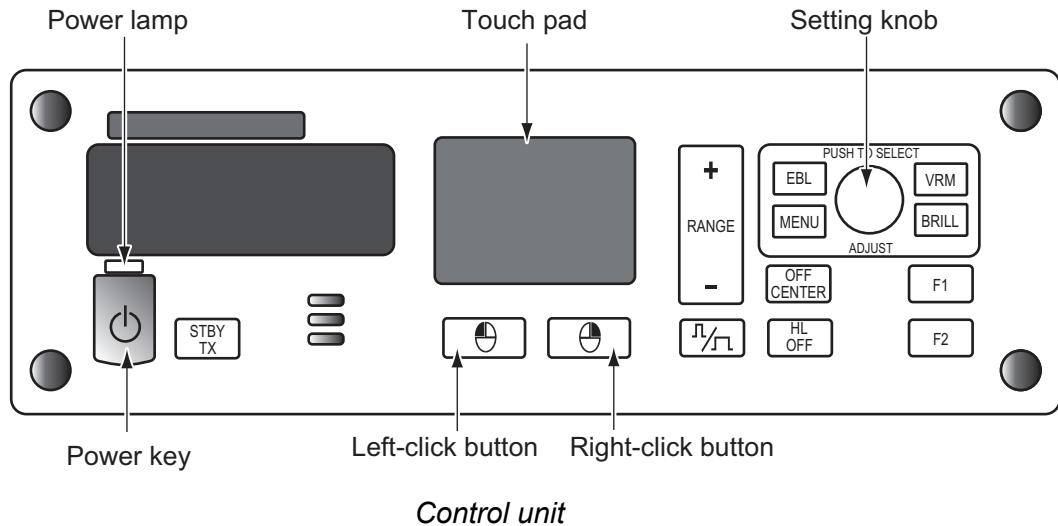

## 3.1 How to Open the Protected Menu

1. Open the cover of the power switch and press the switch to turn on the radar.
2. Press the **MENU** key five times while pressing the **HL OFF** key.

### MAIN menu

- SERVICE MENU
- INITIALIZE menu

### MAIN>CONFIGURATION menu

- INSTALLATION menu

### BRILL menu and CUSTOM menu

You can edit and save the settings for [BRL1-1] and [CUSTOM1-1].

### Back Up general settings

All settings are backed up when the protected menus are unlocked. The saved settings are restored each time the power is turned on.

## 3.2 How to Set Alarms

For alarm details, see section 1.28.2 “Alarm description” in the Operator’s Manual for details.

### Alarm sound level

1. Press the **MENU** key to show the main menu.
2. Use the touch pad to select [13 INITIALIZE], then press the left button (click) to show the [INITIALIAZE] menu.
3. Click [ALARM]→[ALARM SOUND LEVEL] menu.
4. Click the appropriate sound level of an alarm among [OFF], [LOW], [MID] or [HIGH] (default: [MID]).

### How to activate/deactivate alarms

The following alarms can be set on/off.

- [SYSTEM ERROR]: This alarm activates when the system has an error.
  - [SENSOR ERROR]: This alarm activates when the sensor signal has an error.
  - [AIS ALARM]: This alarm activates when the AIS signal has an error.
  - [OTHER WARNING]: For other than the above three alarms.
1. Press the **MENU** key to show the main menu.
  2. Use the touch pad to select [13 INITIALIZE], then press the left button (click) to show the [INITIALIZE] menu.
  3. Click [ALARM], then click the alarm whose settings you want to change.
  4. Click [ON] to activate the alarm. When [OFF] is selected, the alarm indication does not appear and the alarm sound is not generated.

## 3.3 How to Enter Your Ship’s Characteristics

### Ship’s length and width

1. Press the **MENU** key to show the main menu.
2. Use the touch pad to select [13 INITIALIZE], then press the left button (click) to show the [INITIALIAZE] menu.
3. Click [OWN SHIP INFO] to show the [OWN SHIP INFO] menu.
4. Click [LENGTH].
5. Rotate the setting knob to set the ship’s length.
6. Click [WIDTH].
7. Rotate the setting knob to set the ship’s width.

### Conning position

1. Open the [MAIN]>[INITIALIZE]>[OWN SHIP INFO] menu.
2. Click [CONNING - BOW], then input the distance from the bow to the conning position.

- Click [CONNING - PORT], then input the distance from the port line to the conning position.

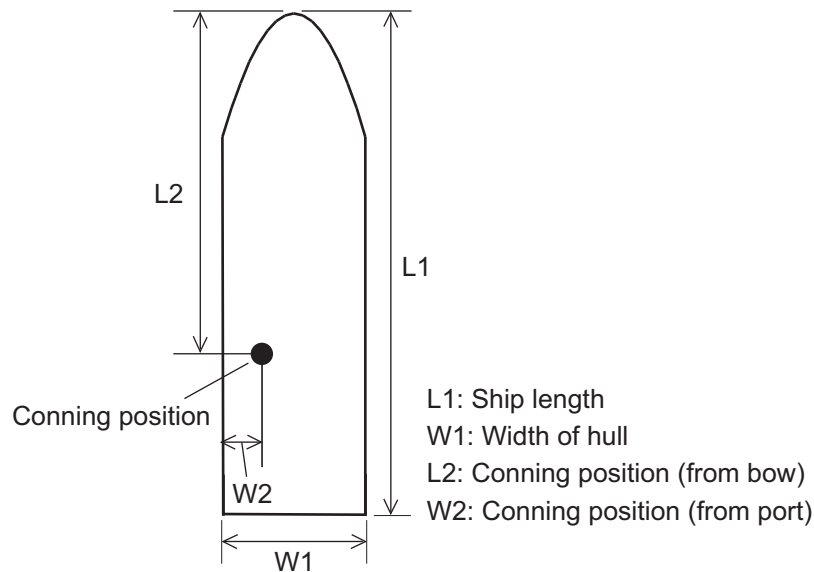

### **Reference point**

Select the antenna position (refer to section 3.9) or CCRP (Consistent Common Reference Point) as the radar reference point.

- Open the [MAIN]>[CONFIGURATION]>[OPERATION] menu.
- Click [REF POINT].
- Click [ANT] or [CCRP] as reference point.

## **3.4 How to Adjust Sweep Timing**

Sweep timing differs with respect to the length of the signal cable between the antenna unit and the processor unit. Adjust sweep timing at installation to prevent the following symptoms:

- The echo of a “straight” target (for example, pier), on the 0.25 NM range, will appear on the display as being pulled inward or pushed outward. See the figures below.
- The range of target echoes will also be incorrectly shown.

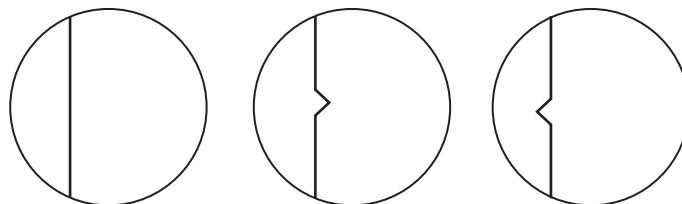

(1) Correct (2) Target pushed inward (3) Target pushed outward

Image of a straight pier with different sweep timings

- Set the controls as shown below:  
GAIN: 80, STC: 0, RAIN: 0, FTC: OFF
- Open the [MAIN]>[CONFIGURATION] menu.
- Click [INSTALLATION] to show the [INSTALLATION] menu.

### 3. ADJUSTMENTS

4. Click [7 TIMING ADJ] and [AUTO] to activate the automatic adjustment, which takes approx. two minutes.
5. After the adjustment is completed, set the radar to the minimum range. Confirm that no echoes are “missing” at the center of the radar screen.  
If echoes are missing, click [9 TIMING ADJ OFFSET] and use the setting knob to adjust the timing manually.

## 3.5 How to Adjust Video Level

Set the pulse length to LONG, confirm that tuning is stable then do the following.

**Note:** Manual adjustment is not possible when auto adjustment is selected.

1. Open the [MAIN]>[CONFIGURATION] menu.
2. Click [INSTALLATION] to show the [INSTALLATION] menu.
3. Click [3 VIDEO ADJ] and [AUTO] in order to automatically adjust the video level.

When using the manual adjustment, refer to the following table.

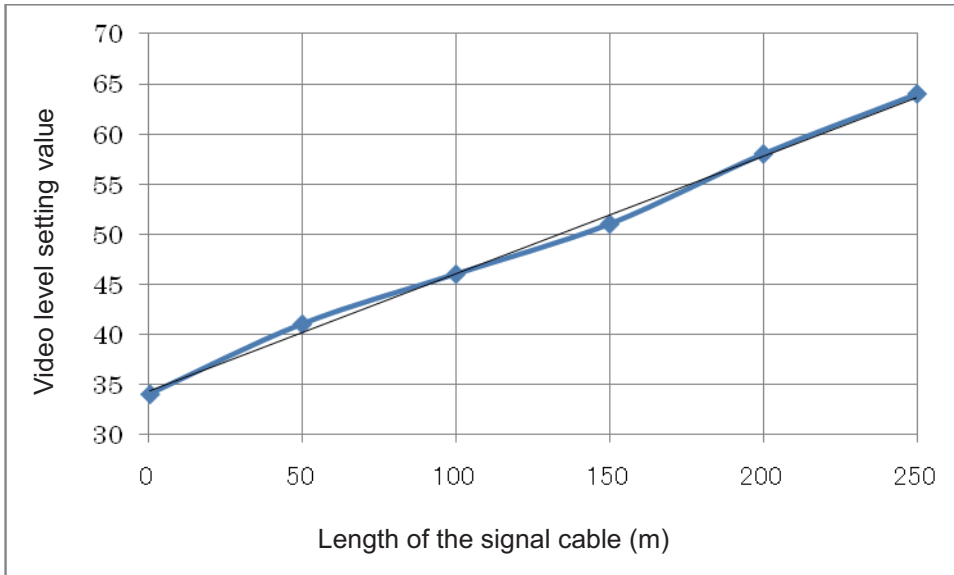

## 3.6 Heading Alignment

You have mounted the antenna unit facing straight ahead in the direction of the bow. Therefore, a small but conspicuous target dead ahead visually should appear on the heading line (zero degrees). In practice, you will probably observe some small bearing error on the display because of the difficulty in achieving accurate initial positioning of the antenna unit. The following adjustment will compensate for this error.

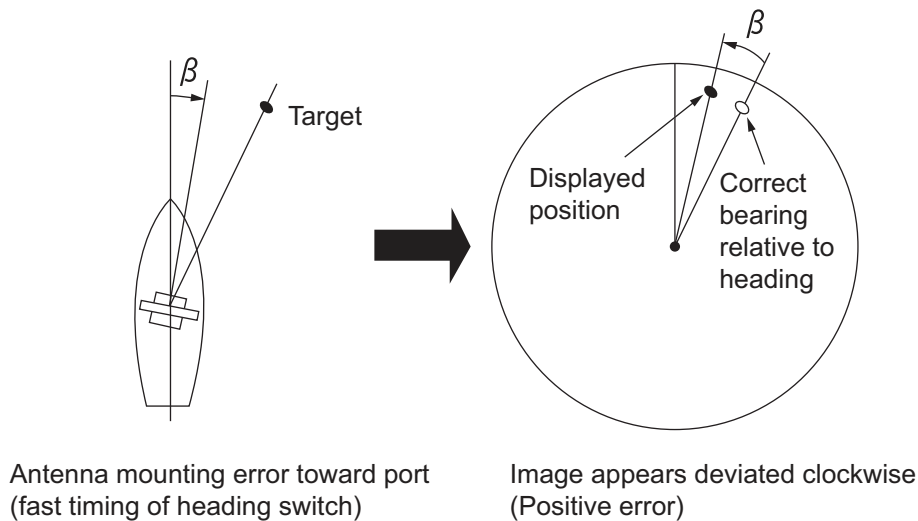
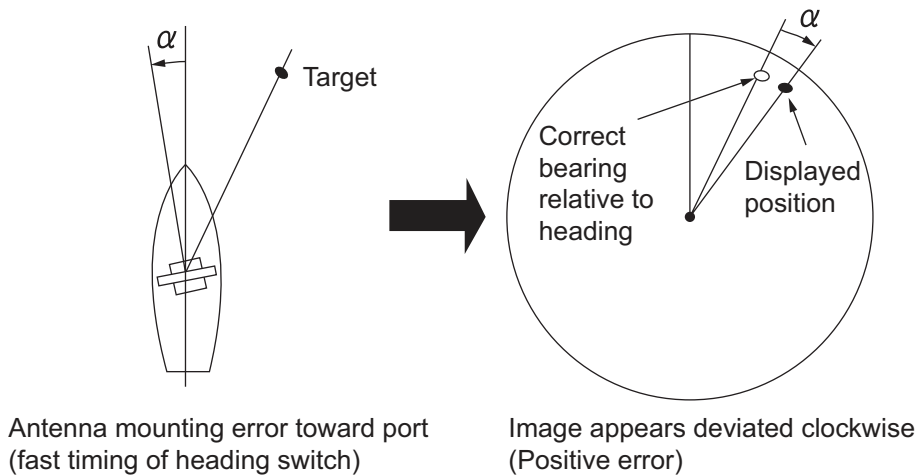

1. Select a stationary target echo at a range between 0.125 and 0.25 NM, preferably near the heading line.
2. Operate the **EBL** control to bisect the target echo.
3. Read the target bearing.
4. Measure the bearing of the stationary target on the navigation chart and calculate the difference between the actual bearing and apparent bearing on the radar screen.
5. Open the [MAIN]>[CONFIGURATION] menu.
6. Click [INSTALLATION] to show the [INSTALLATION] menu.
7. Click [6 HD ALIGN], and enter the bearing difference measured at step 4. The setting range is 0 to 359.9 degrees.
8. Confirm that the target echo is displayed at the correct bearing on the screen.

### 3.7 How to Suppress Main Bang

If main bang appears at the screen center, suppress it as follows.

1. Transmit the radar on a long range and then wait 10 minutes.
2. Adjust gain to show a slight amount of noise on the display.
3. Select the 0.125 NM range, and adjust STC and RAIN.

### 3. ADJUSTMENTS

4. Open the [MAIN]>[CONFIGURATION] menu.
5. Click [INSTALLATION] to show the [INSTALLATION] menu.
6. Click [10 MBS], and enter a suitable value so that the main bang disappears.  
The setting range is 0 to 255.

## 3.8 How to Set the Transmission Stop Area

If there is a sector(s) on the radar display in which radar echoes cannot be received because of an obstruction near the antenna, set the sector(s) on the menu. Click [SECTOR BLANK 1] or [SECTOR BLANK 2] on the [INSTALLATION] menu and enter the referring to the illustration below.

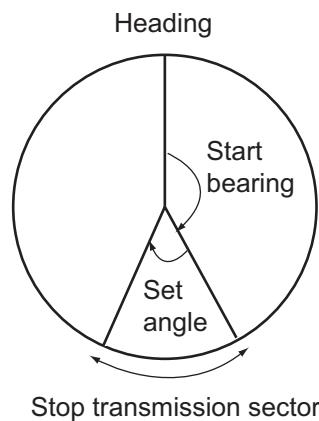

## 3.9 How to Set the Radar Antenna Position

Set the radar antenna position at [SCANNER POSITION] on the [INSTALLATION] menu. To set the antenna position on a barge off the ship, enter a negative value.

- Bow: Input distance from the bow to the antenna unit.
- Port: Set the position of antenna unit from the port line of the ship.

## 3.10 How to Set the GPS Antenna Position

Enter the GPS antenna position from the bow and port sides at the [GPS (FRONT) POSITON] and/or [GPS (AFT) POSITON]. Correct antenna position is necessary to get accurate AIS information.

## 3.11 How to Adjust the ROT/Rudder/Autopilot Graph (Analog Input Only)

The ROT (Rate of Turn), Rudder and Autopilot graphs, which appear at the top of the display, can be adjusted on the INITIALIZE menu.

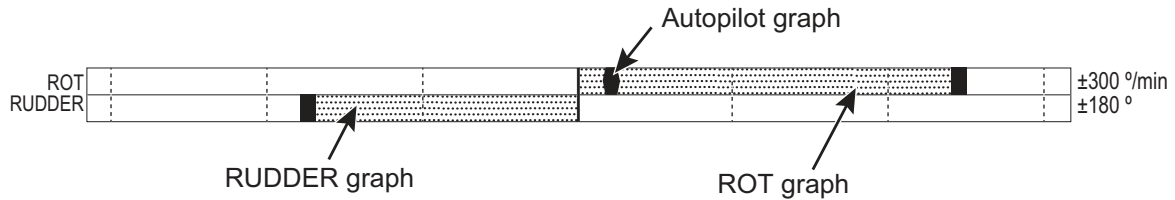

### **ROT, Rudder**

1. Open the [MAIN]>[INITIALIZE] menu.
2. Click [ROT] or [RUDDER].
3. Set the external ROT device to zero (Set rudder to  $0^\circ$ ).
4. Click [OFFSET ADJUST].
5. Set the external ROT device to "test position".
6. Click [GAIN ADJUST].
7. Rotate the setting knob to duplicate the external ROT (or Rudder) indication on the radar.
8. Push the left button.

### **Autopilot**

1. Set external autopilot to "Follow-up".
2. Open the [MAIN]>[INITIALIZE]>[AUTOPILOT] menu.
3. Set the autopilot to  $0^\circ$ .
4. Click [OFFSET ADJUST].
5. Set the autopilot to max. PS (port side) or SB (starboard side).
6. Click [GAIN ADJUST].
7. Rotate the setting knob so that the autopilot indicator on the radar display shows the same heading indication as the associated autopilot.

### 3. ADJUSTMENTS

This page is intentionally left blank.



# APPENDIX 1 JIS CABLE GUIDE

Cables listed in the manual are usually shown as Japanese Industrial Standard (JIS). Use the following guide to locate an equivalent cable locally.

JIS cable names may have up to 6 alphabetical characters, followed by a dash and a numerical value (example: DPYC-2.5).

For core types D and T, the numerical designation indicates the *cross-sectional Area (mm<sup>2</sup>)* of the core wire(s) in the cable.

For core types M and TT, the numerical designation indicates the *number of core wires* in the cable.

## 1. Core Type

- D: Double core power line
- T: Triple core power line
- M: Multi core
- TT: Twisted pair communications (1Q=quad cable)

## 2. Insulation Type

- P: Ethylene Propylene Rubber

## 3. Sheath Type

- Y: PVC (Vinyl)

## 4. Armor Type

- C: Steel

## 5. Sheath Type

- Y: Anticorrosive vinyl sheath

## 6. Shielding Type

- S: All cores in one sheath
- S: Individually sheathed cores
- SLA: All cores in one shield, plastic tape w/aluminum tape
- SLA: Individually shielded cores, plastic tape w/aluminum tape



DPYCY



TPYCY

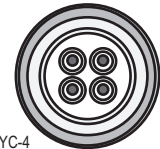

MPYC-4



TTYCSLA-4

EX: <sup>1 2 3 4 5 6</sup> **TTYCYSLA - 4**  
 Designation type | # of twisted pairs

<sup>1 2 3 4</sup> **MPYC - 4**  
 Designation type | # of cores

The following reference table lists gives the measurements of JIS cables commonly used with Furuno products:

Type	Area	Core Diameter	Cable Diameter	Type	Area	Core Diameter	Cable Diameter
DPYC-1.5	1.5mm <sup>2</sup>	1.56mm	11.7mm	TTYCS-1	0.75mm <sup>2</sup>	1.11mm	10.1mm
DPYC-2.5	2.5mm <sup>2</sup>	2.01mm	12.8mm	TTYCS-1T	0.75mm <sup>2</sup>	1.11mm	10.6mm
DPYC-4	4.0mm <sup>2</sup>	2.55mm	13.9mm	TTYCS-1Q	0.75mm <sup>2</sup>	1.11mm	11.3mm
DPYC-6	6.0mm <sup>2</sup>	3.12mm	15.2mm	TTYCS-4	0.75mm <sup>2</sup>	1.11mm	16.3mm
DPYC-10	10.0mm <sup>2</sup>	4.05mm	17.1mm	TTYCSLA-1	0.75mm <sup>2</sup>	1.11mm	9.4mm
DPYCY-1.5	1.5mm <sup>2</sup>	1.56mm	13.7mm	TTYCSLA-1T	0.75mm <sup>2</sup>	1.11mm	10.1mm
DPYCY-2.5	2.5mm <sup>2</sup>	2.01mm	14.8mm	TTYCSLA-1Q	0.75mm <sup>2</sup>	1.11mm	10.8mm
DPYCY-4	4.0mm <sup>2</sup>	2.55mm	15.9mm	TTYCSLA-4	0.75mm <sup>2</sup>	1.11mm	15.7mm
MPYC-2	1.0mm <sup>2</sup>	1.29mm	10.0mm	TTYCY-1	0.75mm <sup>2</sup>	1.11mm	11.0mm
MPYC-4	1.0mm <sup>2</sup>	1.29mm	11.2mm	TTYCY-1T	0.75mm <sup>2</sup>	1.11mm	11.7mm
MPYC-7	1.0mm <sup>2</sup>	1.29mm	13.2mm	TTYCY-1Q	0.75mm <sup>2</sup>	1.11mm	12.6mm
MPYC-12	1.0mm <sup>2</sup>	1.29mm	16.8mm	TTYCY-4	0.75mm <sup>2</sup>	1.11mm	17.7mm
TPYC-1.5	1.5mm <sup>2</sup>	1.56mm	12.5mm	TTYCY-4S	0.75mm <sup>2</sup>	1.11mm	21.1mm
TPYC-2.5	2.5mm <sup>2</sup>	2.01mm	13.5mm	TTYCY-4SLA	0.75mm <sup>2</sup>	1.11mm	19.5mm
TPYC-4	4.0mm <sup>2</sup>	2.55mm	14.7mm	TTYCYS-1	0.75mm <sup>2</sup>	1.11mm	12.1mm
TPYCY-1.5	1.5mm <sup>2</sup>	1.56mm	14.5mm	TTYCYS-4	0.75mm <sup>2</sup>	1.11mm	18.5mm
TPYCY-2.5	2.5mm <sup>2</sup>	2.01mm	15.5mm	TTYCYSLA-1	0.75mm <sup>2</sup>	1.11mm	11.2mm
TPYCY-4	4.0mm <sup>2</sup>	2.55mm	16.9mm	TTYCYSLA-4	0.75mm <sup>2</sup>	1.11mm	17.9mm

# APPENDIX 2 INITIALIZE MENU TREE

---

## [INITIALIZE] menu

Default setting: Bold Italic

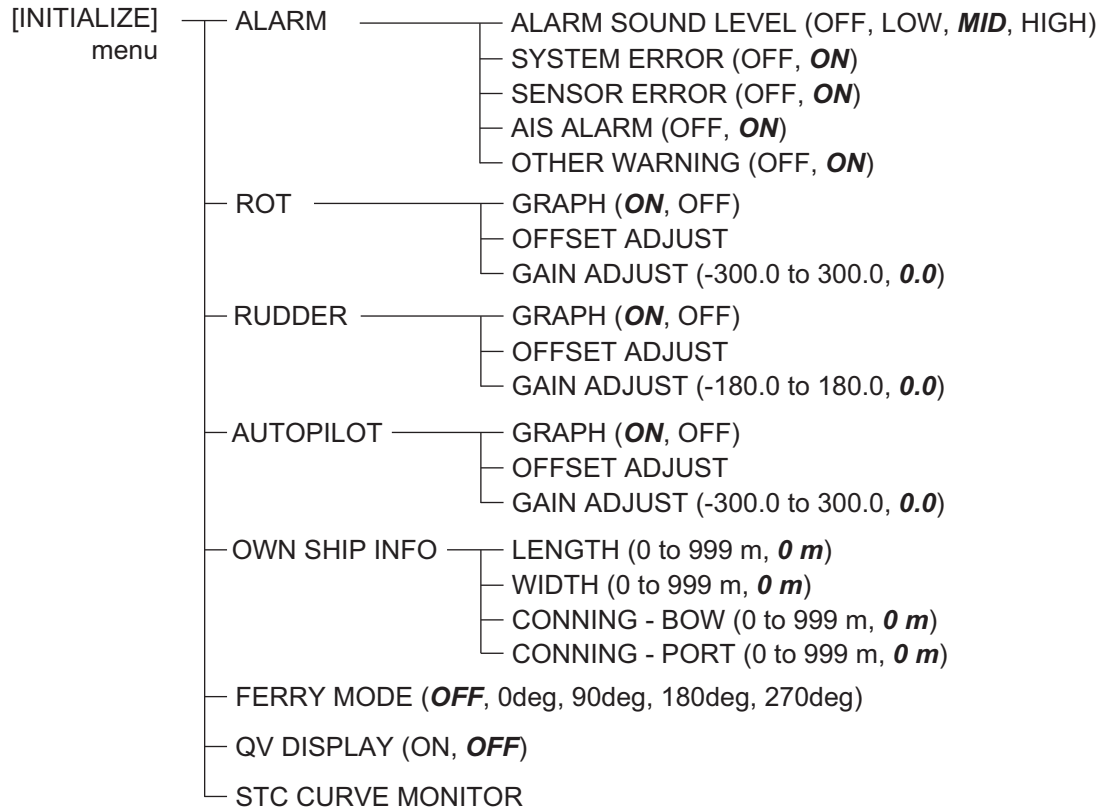

ケーブル導入口  
CABLE ENTRY  
φ25



表2 TABLE 2

アンテナ型式 ANTENNA TYPE	XN21AR (210cm型)	XN24AR (240cm型)
A: 空中線長 ANTENNA LENGTH (mm)	2,160±10	2,550±10
B: 回転安全空間 ANT. CLEARANCE (mm)	2,350	2,700
質量 MASS (kg±10%)	3.8	3.9

表1 TABLE 1

寸法区分 (mm) DIMENSION	公差 (mm) TOLERANCE
L ≤ 50	±1.5
50 < L ≤ 100	±2.5
100 < L ≤ 500	±3
500 < L ≤ 1000	±4
1000 < L ≤ 2000	±5

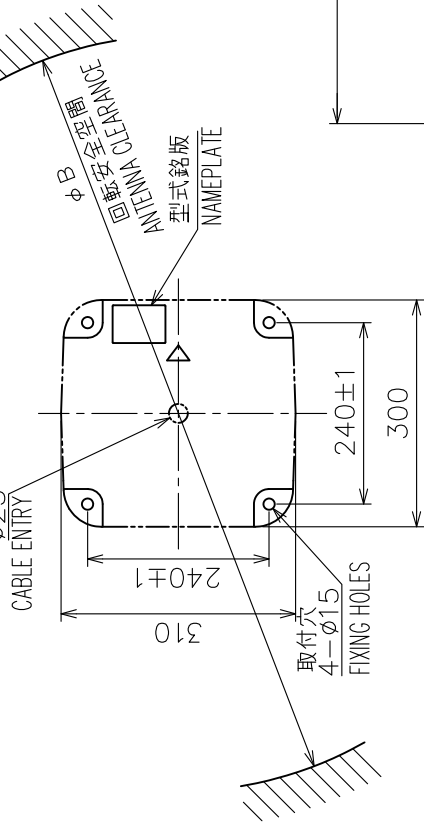
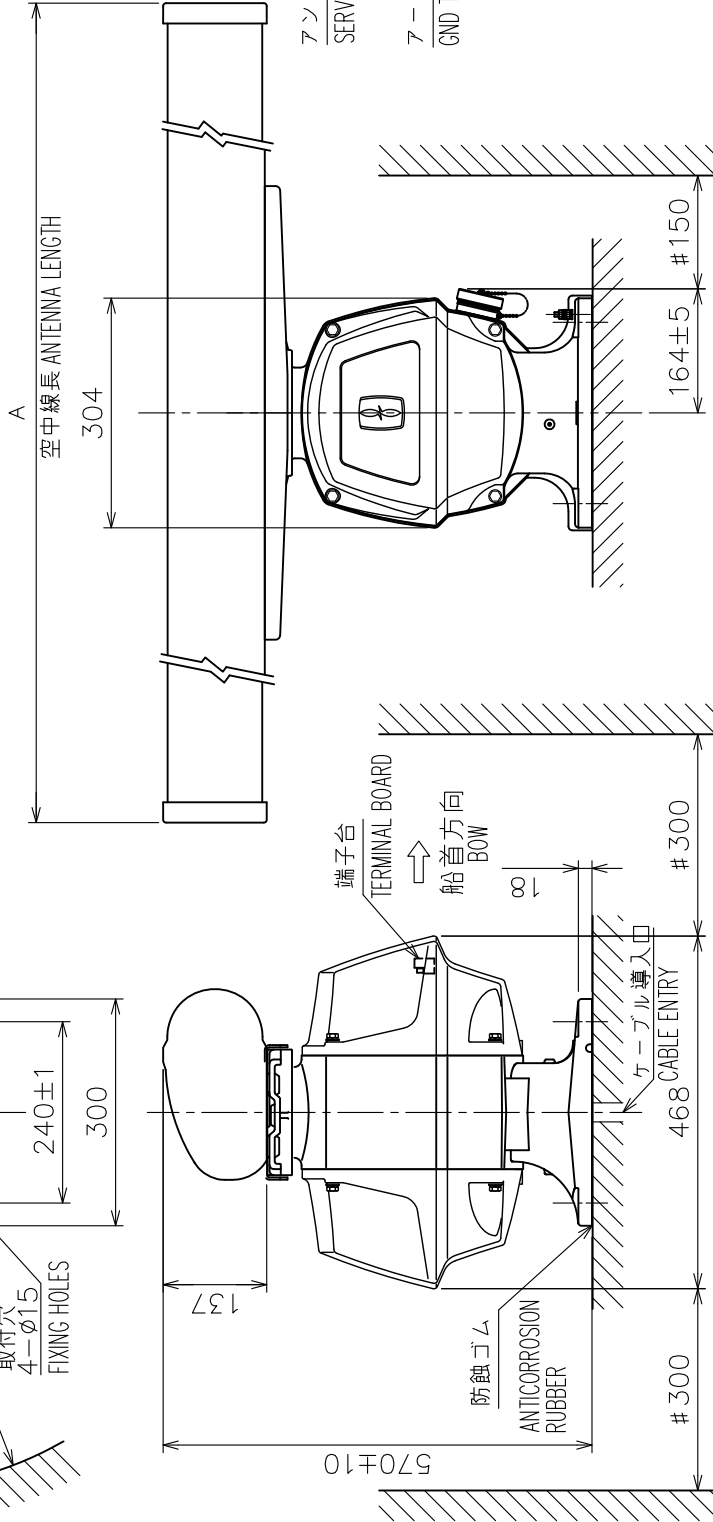

- 注記 1) 指定外の寸法公差は表1による。  
 2) #印寸法は最小サービス空間寸法とする。  
 3) 取付用ネジはM12ボルトを使用のこと。
- NOTE 1. TABLE 1 INDICATES TOLERANCE OF DIMENSIONS WHICH IS NOT SPECIFIED.  
 2. # MINIMUM SERVICE CLEARANCE.  
 3. USE M12 BOLTS FOR FIXING THE UNIT.

DRAWN	10/Oct/2012	I. YAMASAKI	TITLE	RSB-120A/121A (XN21AR/24AR)
CHECKED	10/Oct/2012	H. MAKI	名*	空中線部
APPROVED	12/Oct/2012	H. MAKI	名*	外寸図
SCALE	1/10	MS. SEE TABLE 2 表2参照	NAME	ANTENNA UNIT
DRG. No.	C3614-G03-A	REF. No.	03-178-400G-0	OUTLINE DRAWING

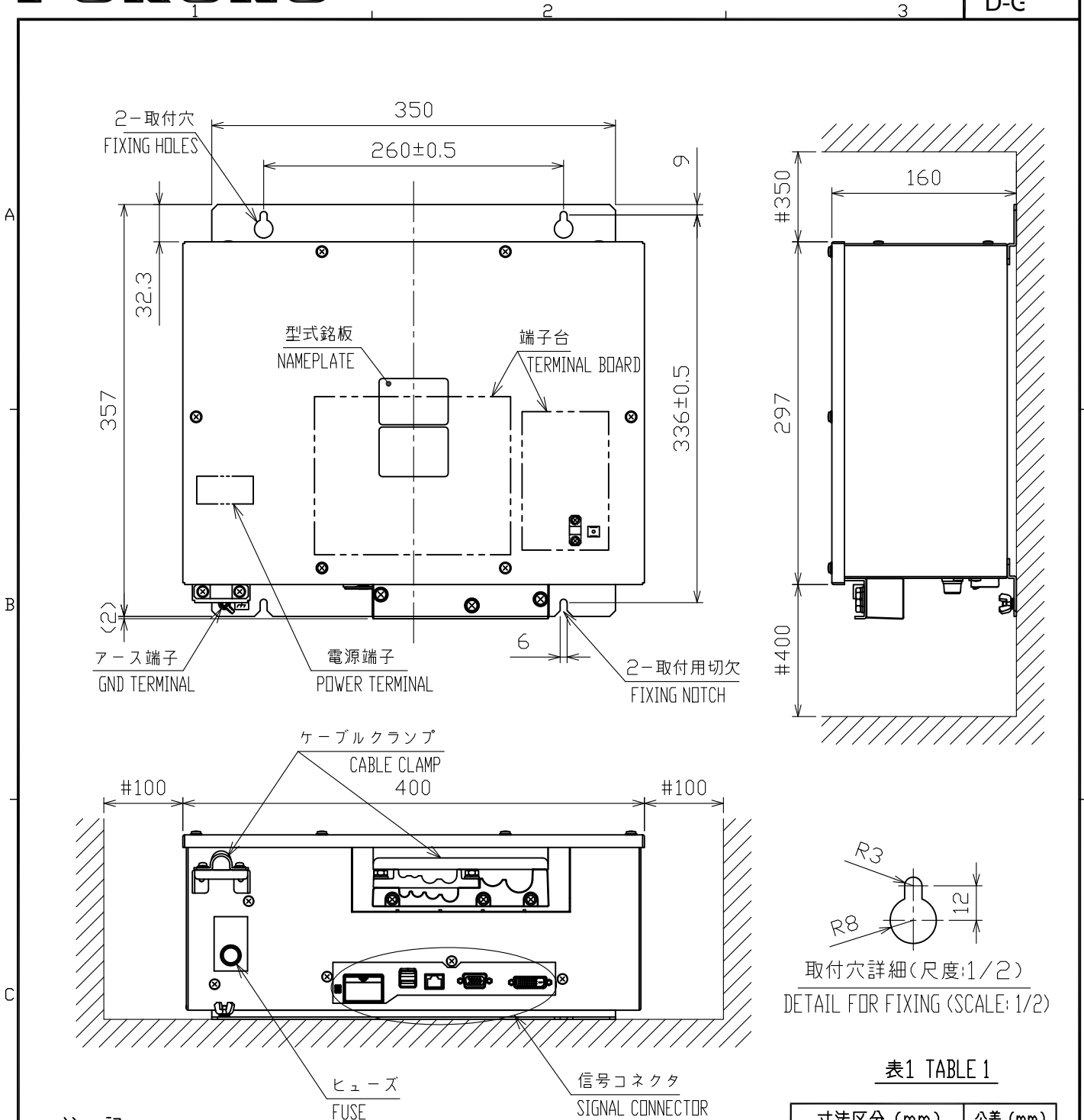

注記

- 1) 指定外の寸法公差は表1による。
- 2) #印寸法は最小サービス空間寸法とする。
- 3) 取付用ネジはM5ボルトまたはトラスタッピンネジ呼び径5×20を使用のこと。

NOTE

1. TABLE 1 INDICATES TOLERANCE OF DIMENSIONS WHICH IS NOT SPECIFIED.
2. #: MINIMUM SERVICE CLEARANCE.
3. USE M5 BOLTS OR TAPPING SCREWS  $\phi 5 \times 20$  FOR FIXING THE UNIT.

表1 TABLE 1  
取付穴詳細(尺度:1/2)  
DETAIL FOR FIXING (SCALE: 1/2)

寸法区分 (mm) DIMENSION	公差 (mm) TOLERANCE
$L \leq 50$	$\pm 1.5$
$50 < L \leq 100$	$\pm 2.5$
$100 < L \leq 500$	$\pm 3$

DRAWN	1/Nov/2017	T.YAMASAKI	TITLE	RPU-026	
CHECKED	1/Nov/2017	H.MAKI	名称	制御部 (壁掛・卓上装備)	
APPROVED	2/Nov/2017	H.MAKI	FR-19x8V-BB	外寸図	
SCALE	1/5	MASS	6.0 $\pm 10\%$ kg	NAME	PROCESSOR UNIT (BULKHEAD/TABLETOP MOUNT)
DWG. No.	C3670-G01-A		REF. No.	03-196-100G-0	OUTLINE DRAWING



表1 TABLE 1

寸法区分 (mm) DIMENSION	公差 (mm) TOLERANCE
L ≤ 50	±1.5
50 < L ≤ 100	±2.5
100 < L ≤ 500	±3

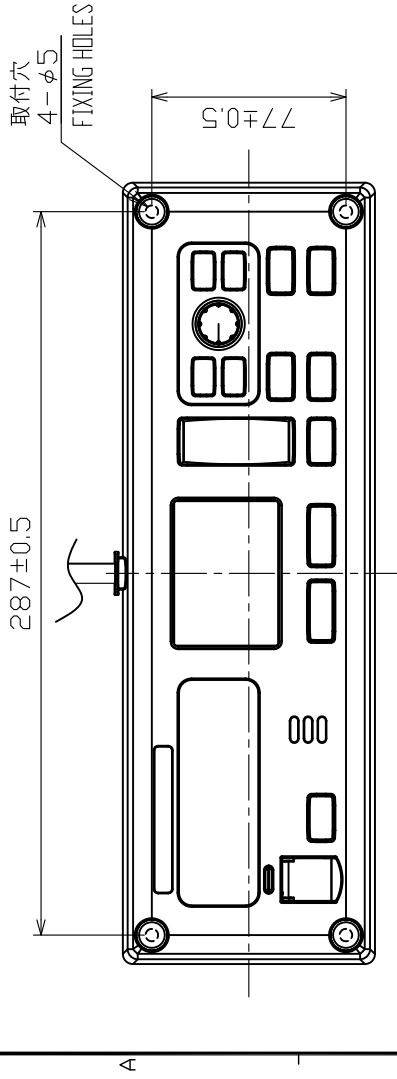
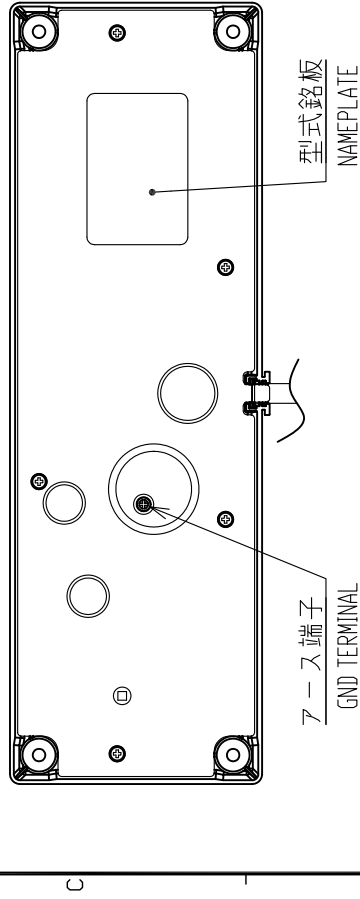
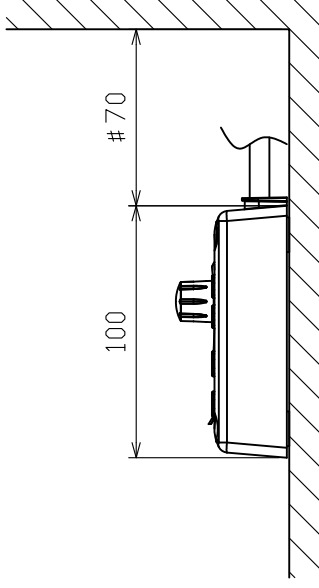
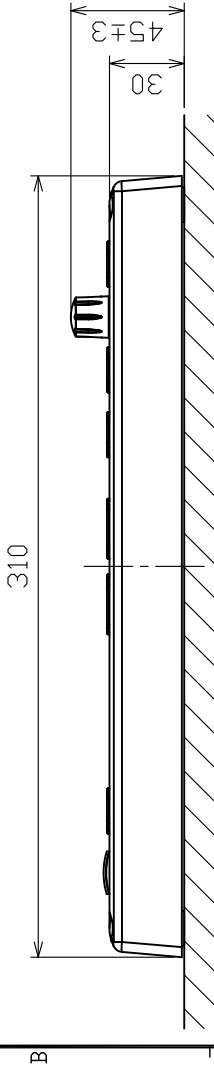

- 注 記
- 1) 指定外の寸法公差は表1による。
  - 2) #印寸法は最小サービスペース寸法とする。
  - 3) 取付ネジはトラスターピンネジ呼び径4×20を使用のこと。

- NOTE
1. TABLE 1 INDICATES TOLERANCE OF DIMENSIONS WHICH IS NOT SPECIFIED.
  2. # MINIMUM SERVICE CLEARANCE.
  3. USE TAPPING SCREWS Ø4x20 FOR FIXING THE UNIT.

DRAWN	1/Nov/2017	I.YAMASAKI	TITLE	RCU-032
CHECKED	1/Nov/2017	H.MAKI	名称	操作部 (卓上装備)
APPROVED	2/Nov/2017	H.MAKI	外寸図	
SCALE	1/3	1:1	WAVE	CONTROL UNIT (TABLETOP MOUNT)
DESIGN	C3670-602-A		質量はケーブル(5m)を含む。 MASS INCLUDES 5m CABLE.	
			REF. No.	03-196-200G-0
			OUTLINE DRAWING	

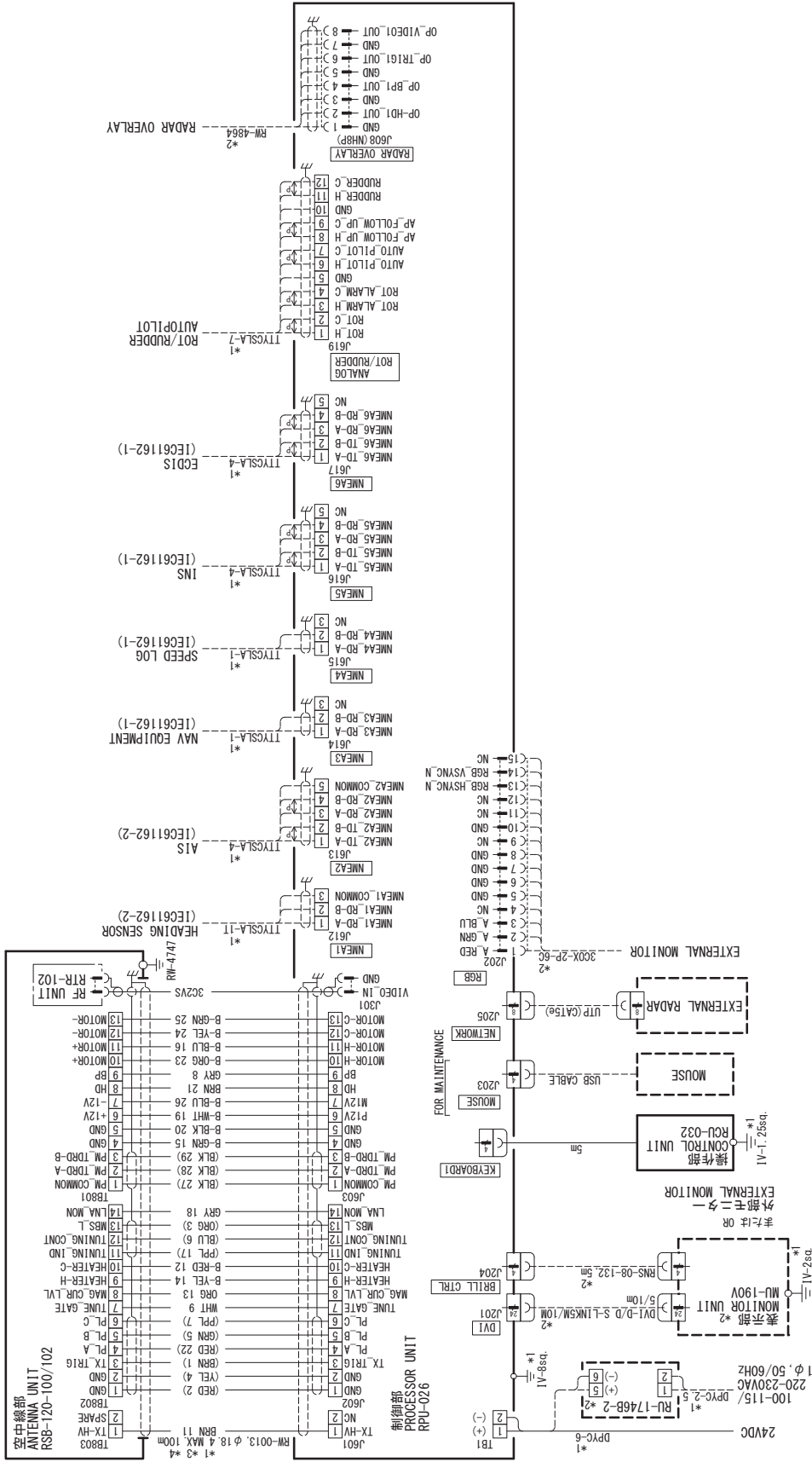

TENTATIVE  
暫定

- 注記
- \*1) RHN手配。
  - \*2) オプション。
  - \*3) ( ) 内のカラーコードは内側シールド内の線を示す。
  - \*4) シールドは両ユニット側で完全にアースすること。
- NOTE
- \*1: PREPARED BY RHN.
  - \*2: OPTION.
  - \*3: WIRE COLOR CODE ( ) : INNER WIRES. B: LARGE WIRES.
  - \*4: SHIELD SHOULD BE EFFECTIVELY GROUNDING AT BOTH UNIT ENDS.

DRAWN	31/Oct/2017	T. YAMASAKI	FR-1908V/1918V-BB
CHECKED	31/Oct/2017	H. MAKI	リバーレーダー
APPROVED			相互結線図
SCALE	MASS	kg	RIVER RADAR
DWG. No.	C3670-C01-1	REF. No.	03-178-6001-1
INTERCONNECTION DIAGRAM			
FURUNO ELECTRIC CO., LTD.			

**ECF**

(Elemental Chlorine Free)

The paper used in this manual  
is elemental chlorine free.

**FURUNO ELECTRIC CO., LTD.**

9-52 Ashihara-cho,  
Nishinomiya, 662-8580, JAPAN

• FURUNO Authorized Distributor/Dealer

All rights reserved. Printed in Japan

Pub. No. IME-36700-Z

(MISU) FR-1908V-BB

A : 0000  
Z : NOV. 06, 2017



0 0 0 1 9 4 7 5 2 1 0