

# *Installation Manual*

## **RADAR SENSOR**

### **Model DRS6A X-Class**

---

<b>SAFETY INSTRUCTIONS .....</b>	<b>i</b>
<b>SYSTEM CONFIGURATION .....</b>	<b>iii</b>
<b>EQUIPMENT LISTS.....</b>	<b>iv</b>
<b>1. INSTALLATION AND WIRING.....</b>	<b>1</b>
1.1 Mounting Considerations .....	1
1.2 Included Items.....	3
1.3 Required Tools and Materials .....	4
1.4 Fastening the Radiator to the Radiator Bracket.....	5
1.5 Mounting the Antenna Unit .....	7
1.6 Wiring.....	10
<b>2. INITIAL SETUP.....</b>	<b>13</b>
2.1 Initial Setup for TZT9/TZT14/TZTB8 .....	13
2.2 Initial Setup for TZTL12F/TZTL15F .....	16
<b>3. MAINTENANCE, TROUBLE SHOOTING.....</b>	<b>18</b>
3.1 Maintenance .....	19
3.2 Troubleshooting .....	19
3.3 Replacement of Fuse.....	20
3.4 Life of Parts.....	20
<b>SPECIFICATIONS .....</b>	<b>SP-1</b>
<b>OUTLINE DRAWING.....</b>	<b>D-1</b>
<b>INTERCONNECTION DIAGRAM .....</b>	<b>S-1</b>

**FURUNO ELECTRIC CO., LTD.**[www.furuno.com](http://www.furuno.com)

All brand and product names are trademarks, registered trademarks or service marks of their respective holders.









# SAFETY INSTRUCTIONS







The installer of the equipment must read the safety instructions before attempting to install the equipment.

 <b>WARNING</b>	Indicates a potentially hazardous situation which, if not avoided, could result in death or serious injury.
--	---

 <b>CAUTION</b>	Indicates a potentially hazardous situation which, if not avoided, can result in minor or moderate injury.
--	--

 Warning, Caution	 Prohibitive Action	 Mandatory Action
--	--	--

 <b>WARNING</b>	
	<b>Do not open the equipment unless you are well familiar with electrical circuits.</b> Only qualified personnel should work inside the equipment.
	<b>Do not disassemble or modify the equipment.</b> Fire, electrical shock or serious injury can result.
	<b>Wear a safety belt and hard hat when working on the antenna unit.</b> Serious injury or death can result if someone falls from the radar mast.
	<b>Construct a suitable service platform from which to install the antenna unit.</b> Serious injury or death can result if someone falls from the radar mast.
	<b>Turn off the power at the switchboard before beginning the installation.</b> Fire or electrical shock can result if the power is left on.

 <b>WARNING</b>	
	<b>Keep the objects away from the antenna unit, so as not to impede rotation of the antenna.</b> Fire, electrical shock or serious injury can result.
	<b>Be sure that the power supply is compatible with the voltage rating of the equipment.</b> Connection of an incorrect power supply can cause fire or damage the equipment.
	<b>Use only the specified power and signal cable.</b> Fire or damage to the equipment can result if a different cable is used.
	<b>Use the proper fuse.</b> Use of a wrong fuse can damage the equipment or cause fire.
	<b>Do not depend one navigation device for the navigation of the vessel.</b> For the safety of vessel and crew, the navigator must check all aids available to confirm position.

**⚠ WARNING**

The radar antenna emits electromagnetic radio frequency (RF) energy which can be harmful, particularly to your eyes. Never look directly into the antenna aperture from a close distance while the radar is in operation or expose yourself to the transmitting antenna at a close distance.

Distances at which RF radiation levels of 100, 50 and 10 W/m<sup>2</sup> exist are given in the table below.

Radiator	100 W/m <sup>2</sup>	50 W/m <sup>2</sup>	10 W/m <sup>2</sup>
XN10A	0.1m	0.5m	3m
XN12A	N/A	0.4m	2.2m
XN13A	N/A	0.2m	1.9m

**⚠ CAUTION**

Ground the equipment to prevent mutual interference.



Observe the following compass safe distances to prevent deviation of a magnetic compass:

Model	Standard compass	Steering compass
DRS6A X-Class	1.40 m	0.90 m



It is recommended that you connect the antenna unit to a disconnecting device (circuit breaker, etc.) to control the power.

**WARNING LABEL**

A warning label is attached to the antenna unit. Do not remove the label. If the label is missing or damaged, contact your dealer about replacement.

<b>WARNING</b>	<b>警告</b>
To avoid electrical shock, do not remove cover. No user-serviceable parts inside.	感電の恐れあり。 サービスマン以外の方はカバーを開けないで下さい。内部には高電圧部分が多い数多くあり、万一さわると危険です。

Name: Warning Label (2)

Type: 03-129-1001-3

Code No: 100-236-743

# SYSTEM CONFIGURATION

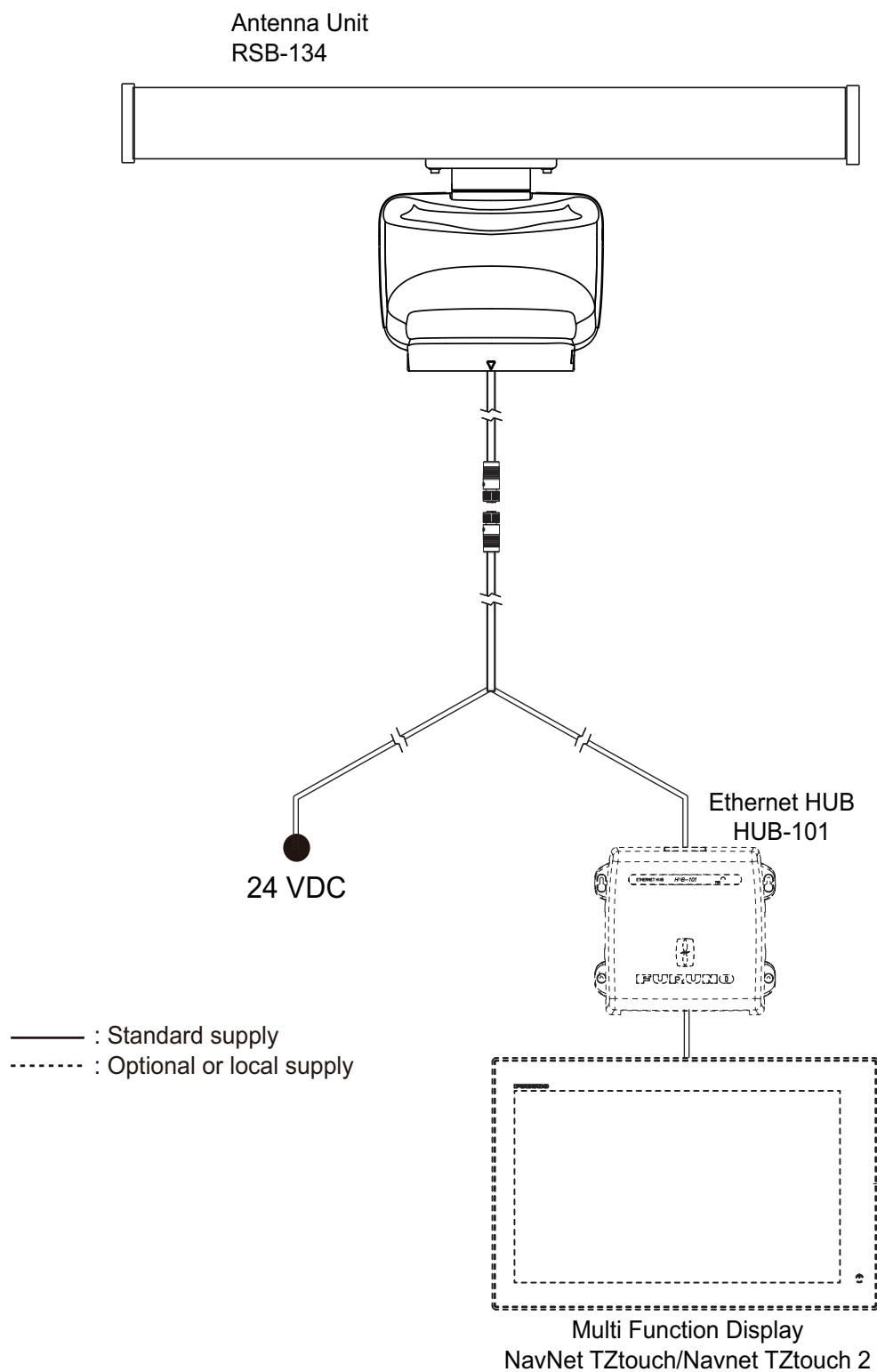

The DRS6A X-Class is compatible with the FURUNO Multi Function Displays shown below. The combination with other models may not operate properly.

- NavNet TZtouch: TZT9, TZT14, TZTBB
- NavNet TZtouch2: TZTL12F, TZTL15F

# EQUIPMENT LISTS

## Standard supply

Name	Type	Code No.	Qty	Remarks
Scanner Unit	RSB-134	-	1	
Radiator	XN10A	-	1	3.4 ft
	XN12A	-		4 ft
	XN13A	-		6 ft
Installation Materials	TBD	TBD	1	For scanner unit
	TBD	TBD	1	For radiator
	CP03-36400	000-027-211	1	Power/LAN cable, 10 m
	CP03-36410	000-027-212		Power/LAN cable, 15 m
	CP03-36420	000-027-213		Power/LAN cable, 20 m
CP03-36430	000-027-214	Power/LAN cable, 30 m		
Spare Parts	TBD	TBD	1	Fuse

## Optional supply

Name	Type	Code No.	Remarks
LAN Cable	MOD-Z072-020+	001-167-880-10	2 m
	MOD-Z072-050+	001-167-890-10	5 m
	MOD-Z072-100+	001-167-900-10	10 m
Joint Box	TL-CAT-012	000-167-140-10	For LAN cable extension*

\*: After the wiring, it is required to wind the vinyl tape around the LAN connector to waterproof.

# 1. INSTALLATION AND WIRING

## NOTICE

**Do not apply paint, anti-corrosive sealant or contact spray to coating or plastic parts of the equipment.**

Those items contain organic solvents that can damage coating and plastic parts, especially plastic connectors.

## 1.1 Mounting Considerations

Select a mounting location, keeping in mind in the following points:

- Install the antenna unit on the hardtop, radar arch or on a mast on an appropriate platform.

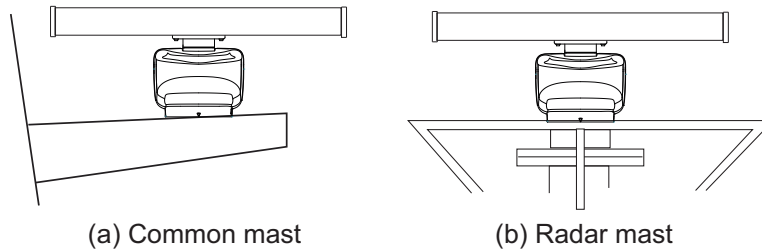

- Locate the antenna unit where there is a good all-round view with, as far as possible, no part of the ship's superstructure or rigging intercepting the scanning beam. Any obstruction will cause shadow sectors and decrease the radiator's performance (beam width, side-lobe level, etc.). The loss of the radiator's performance cause the deterioration of the radar's observation (bearing resolution, etc.) and false echoes. A mast for instance, with a diameter considerably less than the horizontal beam width of the radiator, will cause only a small shadow sector, but a horizontal spreader or cross trees in the same horizontal plane as the antenna unit would be a much more serious obstruction; you would need to place the antenna unit well above or below it. Be sure there are no metallic objects near the antenna.

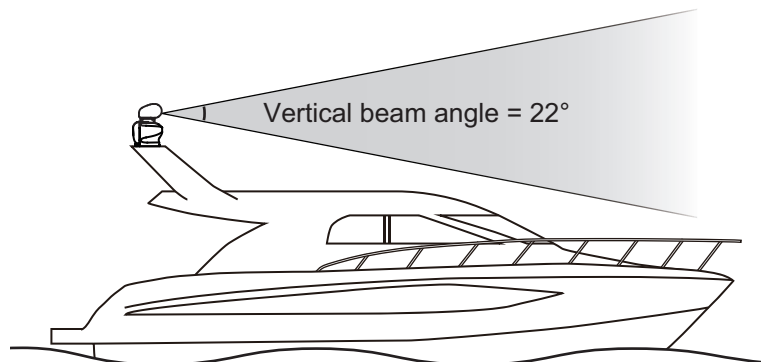

- It is rarely possible to place the antenna unit where a completely clear view in all directions is available. Thus, you should determine the angular width and relative bearing of any shadow sectors for their influence on the radar at the first opportunity after fitting.

- In order to reduce the chance of picking up electrical interference, avoid where possible routing the power cable near other electrical equipment on-board. Also, avoid running the cable in parallel with other power cables.
- It is not recommended to install the antenna unit on the hardtop of a cabin. Vibrations from the antenna unit will pass through the hardtop and into the cabin.

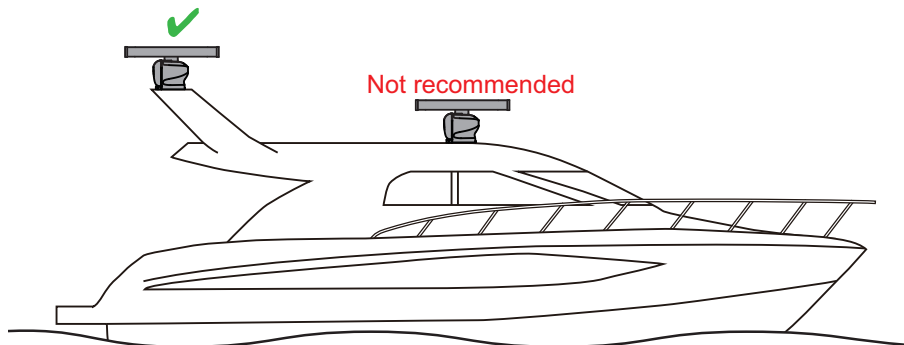

- It is not recommended to install the antenna unit on the off-center position. The radar echoes on the display may not be aligned with the actual target's bearing.

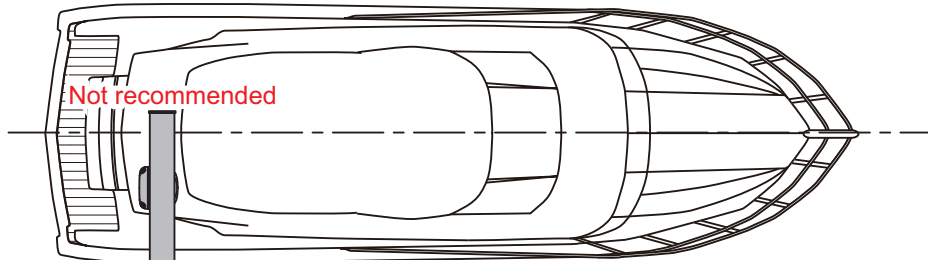
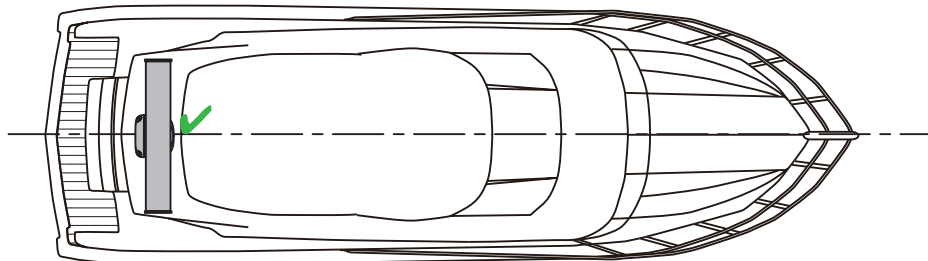

- Select a location that does not allow water to accumulate at the base of the antenna unit.
- A magnetic compass will be affected if the antenna unit is too close to the compass. Observe the compass safe distances mentioned in the SAFETY INSTRUCTIONS to prevent interference to a magnetic compass.
- Do not paint the radiator to ensure proper emission of the radar waves.
- Make the maintenance space shown in the outline drawing for maintenance and checking purpose.
- When this antenna unit is to be installed on a large vessel, consider the following points:
  - The supplied power/LAN cable runs between the antenna unit and display (or ethernet HUB) and comes in lengths of 10 m, 15 m, 20 m or 30 m. Select the length when purchasing.
  - Deposits and fumes from a funnel or other exhaust vent can adversely affect the aerial performance and hot gases may distort the radiator portion. The antenna unit must not be mounted where the temperature is more than 55°C (131°F).



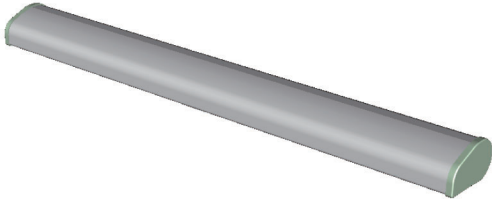

## 1.2 Included Items

**Radiator**

- Radiator\* (1 pcs):  
3.4 ft, 4 ft or 6 ft

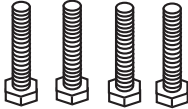

- Flat washer (M8, 4 pcs)
- Spring washer (M8, 4 pcs)
- Hex. bolt (M8×30, 4 pcs)
- O-ring (1 pcs)
- Silicone rubber (1 pcs)











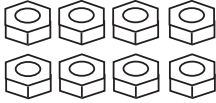

**Scanner Unit**

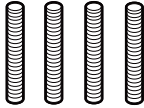
- Scanner Unit (1 pcs)



- Flat washer (M12, 4 pcs)
- Spring washer (M12, 4 pcs)
- Hex nut (M12, 8 pcs)
- Corrosion-proof rubber pad (4 pcs)
- Stud bolt (M12×60, 4 pcs)
- Spare fuse (1 pcs)  
(5 A)
- Documents (1 set):  
Mounting template is included.

**Power/LAN cable**

- Power/LAN cable\* (1 pcs): 10 m, 15 m, 20 m or 30 m

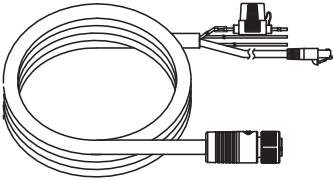

\*: Select the length when purchasing.



## 1.3 Required Tools and Materials

Prepare the tools and materials shown below to install the antenna unit.

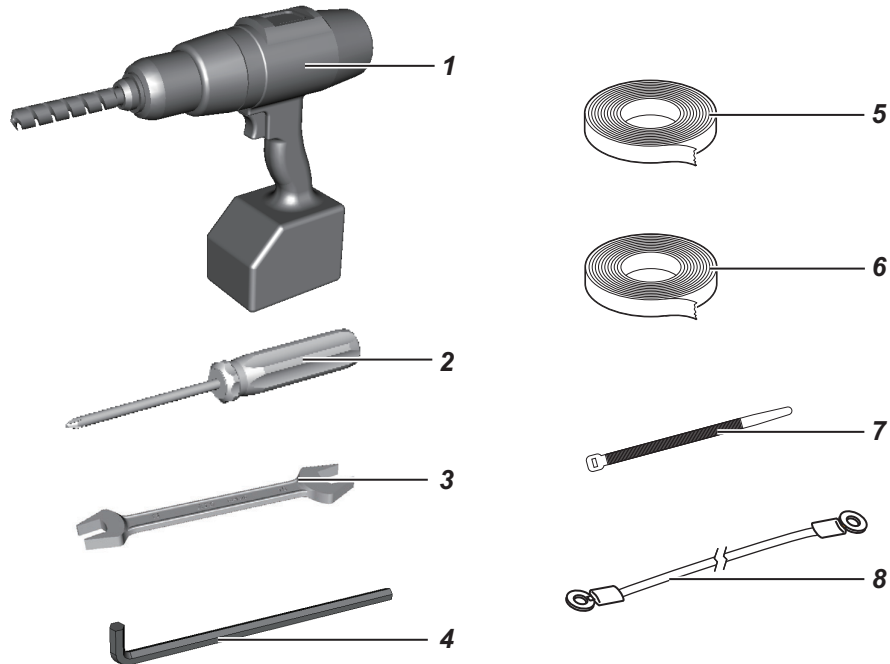

No.	Name	Remarks
1	Electrical drill	For making the mounting holes, drill bit: $\phi$ 15 mm
2	Phillips-head screw driver	#3, for fixing the cable cover
3	Wrench	For M10 (Hex. size 17 mm) and M12 (Hex. size 19 mm)
4	Hex. L-wrench	For fixing the stud bolts (Hex. size 6 mm)
5	Self-vulcanizing tape	For waterproofing the junction of connectors
6	Vinyl tape	
7	Cable tie	For fixing the cables
8	Ground wire	IV-2sq

## 1.4 Fastening the Radiator to the Radiator Bracket

1. Remove the radiator cap from the radiator bracket.

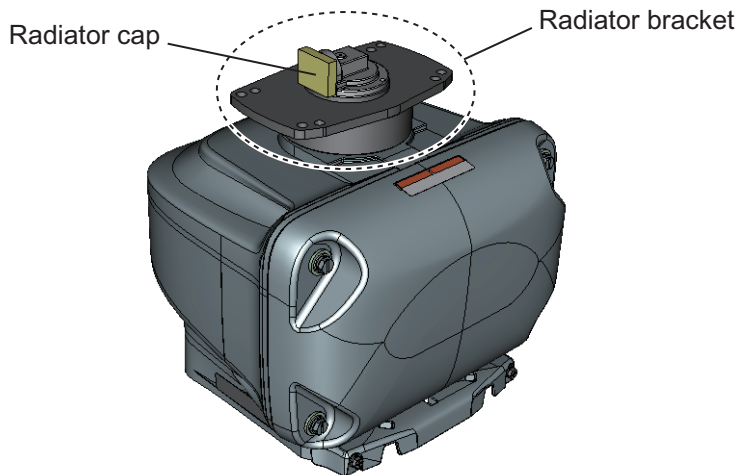

2. Apply the silicone rubber to the surface of the radiator bracket as shown in the figure below.

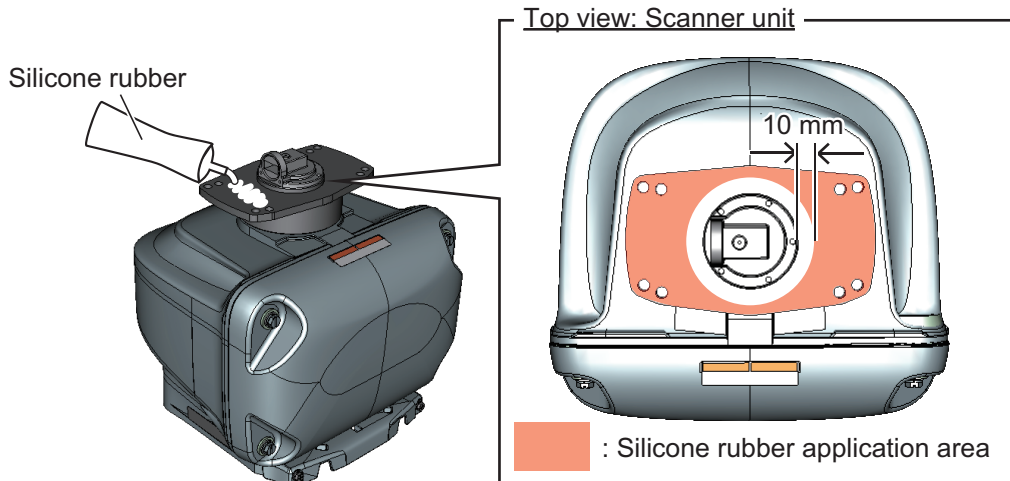

3. Set the O-ring to the radiator bracket.

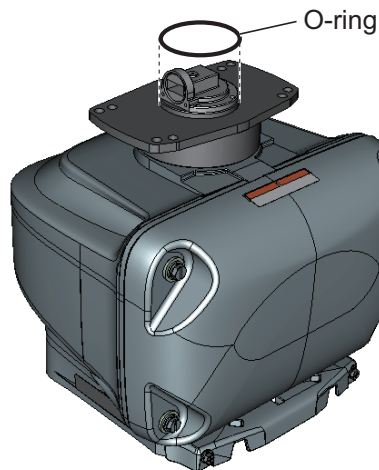

4. Apply the silicone rubber to the thread holes on the bottom of the radiator (4 locations).

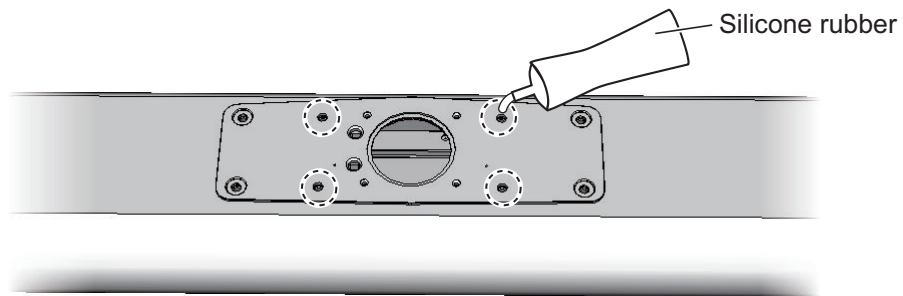

Bottom view: Radiator

5. Apply the silicone rubber to the hex. bolts (M8×30, 4 pcs).
6. Fasten the radiator to the radiator bracket, using the hex bolts (M8×30), flat washers (M8) and spring washers (M8).

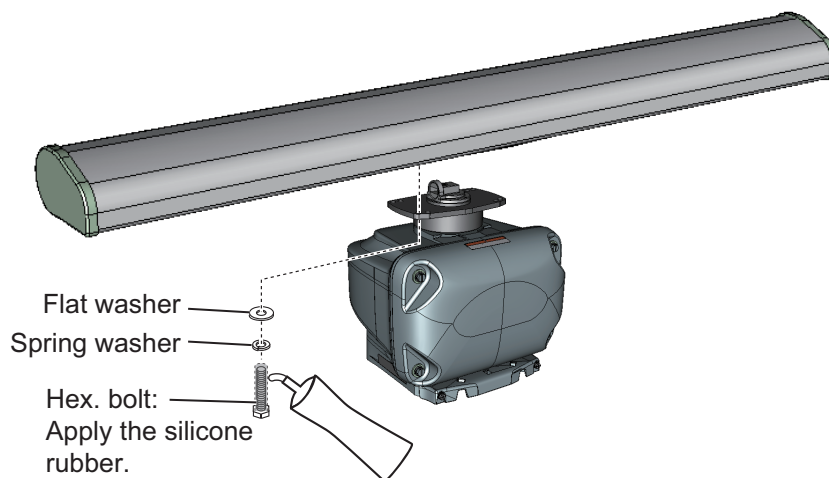

7. Apply the silicone rubber to the holes and junction between the radiator and radiator bracket.

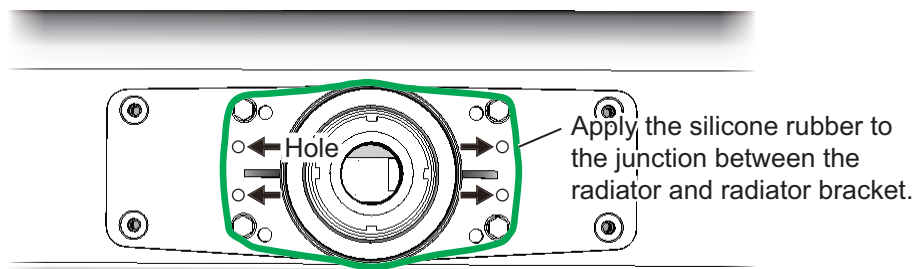

## 1.5 Mounting the Antenna Unit

The antenna unit can be mounted using the fixing holes on the outside (200 × 200 mm) or inside (140 × 150 mm) the antenna unit. Normally, use the outside fixing holes. When 140 × 150 mm fixing holes already exist on the mounting platform, use the inside fixing holes.

### Hoisting the antenna unit

- When you hoist the antenna unit, set belt slings to the radiator bracket. Do not set belt slings to the radiator - the radiator may get damaged.

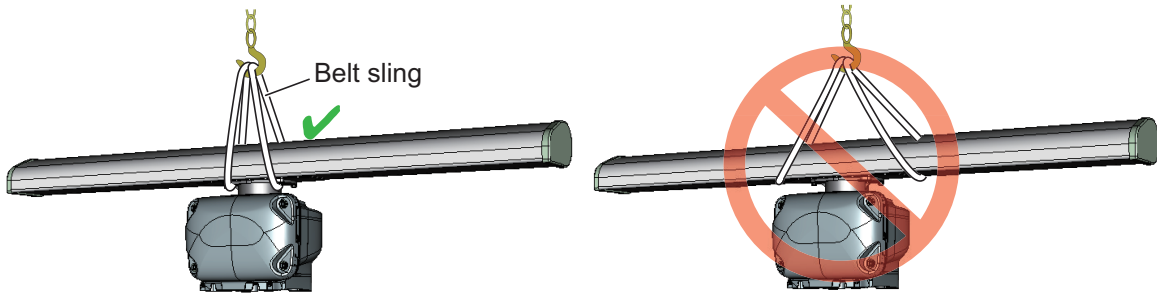

**OK:** Belt slings are set to the radiator bracket.      **WRONG:** Belt slings are set to the radiator.

- Hoist the antenna unit slowly. If the antenna unit is hoisted too quickly, shock is applied to the radiator bracket, which can damage the bracket.

1. Use the mounting template to drill four fixing holes in the mounting location.

**Note:** The holes must be parallel with the fore and aft line.

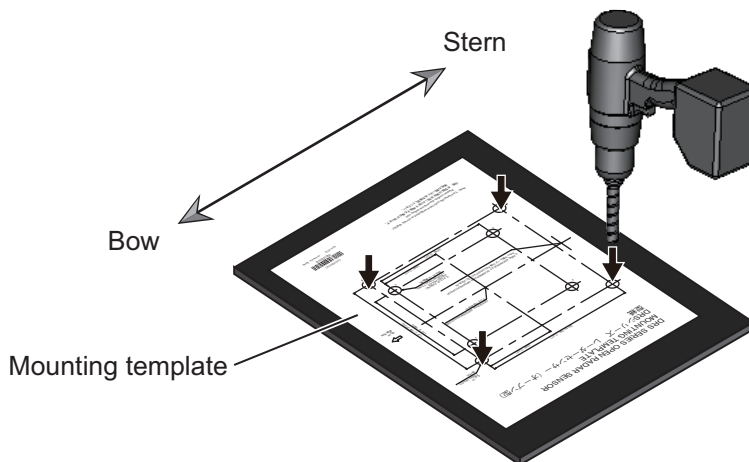

2. Attach four corrosion-proof rubber pads to the mounting holes.

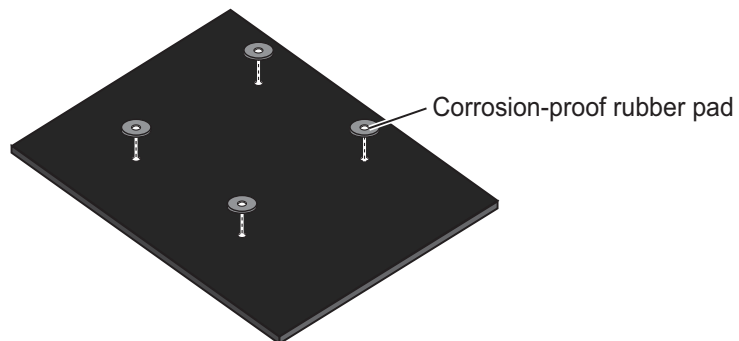

3. Insert four stud bolts (M12×60) into the threaded holes in the antenna unit.

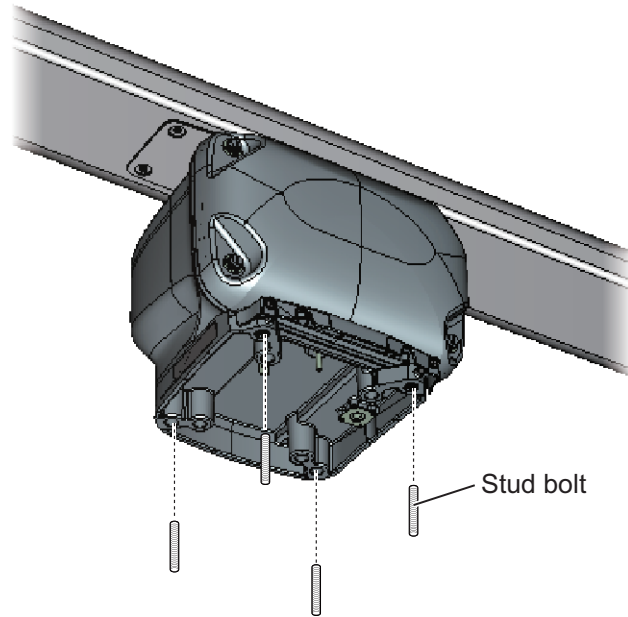

4. Put the antenna unit on the mounting platform with the BOW mark on the unit aligned with the ship's bow.

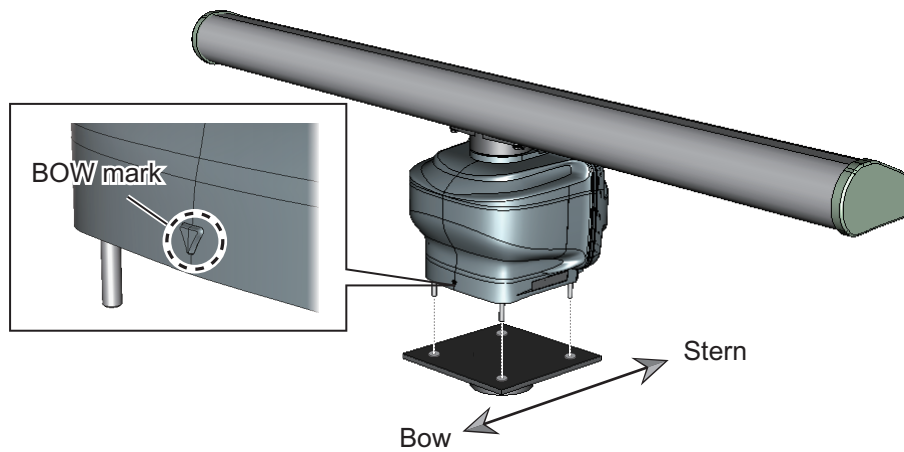

1. INSTALLATION AND WIRING

5. Fix the antenna unit, using the flat washers (M12), spring washers (M12), and hex. nuts (M12).

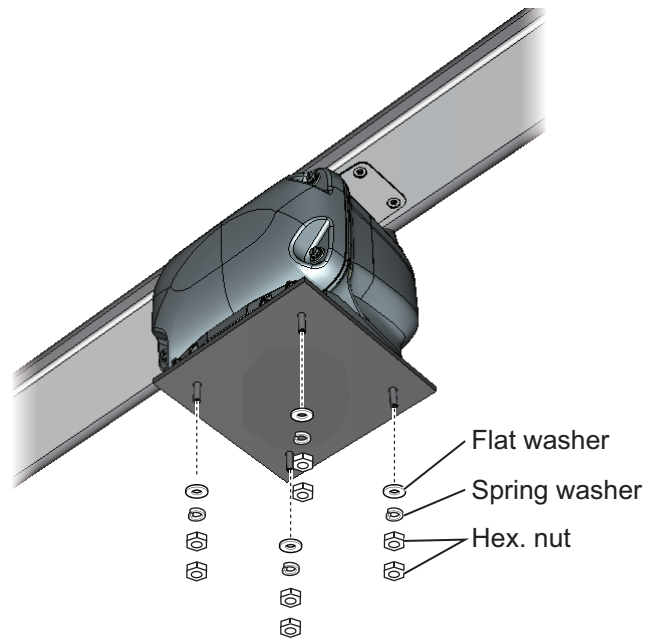

6. Apply the silicone rubber to the flat washers, spring washers, and hex. nuts.

Detailed view

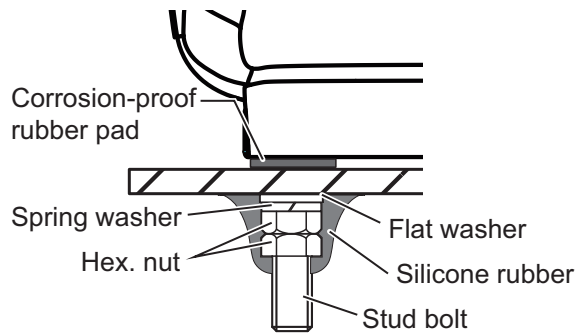

## 1.6 Wiring

### Wiring considerations

- Turn off the power at the switchboard before beginning the wiring.
  - The power/LAN cable has connectors. Do not cut the power/LAN cable.
  - When you replace the DRS4A/6A/12A/25A with the DRS6A X-Class, the existing cable cannot be used. Use the power/LAN cable supplied with the DRS6A X-Class.
1. Unfasten two screws to remove the cable cover.

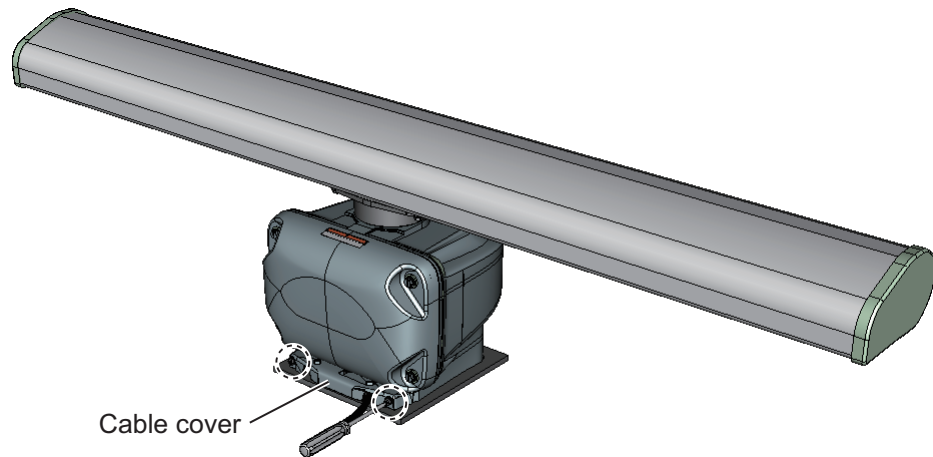

2. Connect the power/LAN cable to the antenna cable that is pre-attached to the antenna unit.

