

FURUNO

GPS Navigator

Model **GP-33**



OPERATOR'S MANUAL



FURUNO ELECTRIC CO., LTD.

www.furuno.com



ECF
(Elemental Chlorine Free)
The paper used in this manual
is elemental chlorine free.

FURUNO ELECTRIC CO., LTD.

9-52, Ashihara-cho,
Nishinomiya, 662-8580, JAPAN

•FURUNO Authorized Distributor/Dealer

All rights reserved. Printed in Japan

A: JAN. 2010
G1: DEC. 16, 2014

Pub. No. OME-44580-G1
(ETMI) GP-33



IMPORTANT NOTICE

General

- This manual has been authored with simplified grammar, to meet the needs of international users.
- The operator of this equipment must read and follow the descriptions in this manual. Wrong operation or maintenance can cancel the warranty or cause injury.
- Do not copy any part of this manual without written permission from FURUNO.
- If this manual is lost or worn, contact your dealer about replacement.
- The contents of this manual and equipment specifications can change without notice.
- The example screens (or illustrations) shown in this manual can be different from the screens you see on your display. The screens you see depend on your system configuration and equipment settings.
- Save this manual for future reference.
- Any modification of the equipment (including software) by persons not authorized by FURUNO will cancel the warranty.
- All brand and product names are trademarks, registered trademarks or service marks of their respective holders.

How to discard this product

Discard this product according to local regulations for the disposal of industrial waste. For disposal in the USA, see the homepage of the Electronics Industries Alliance (<http://www.eiae.org/>) for the correct method of disposal.

How to discard a used battery

Some FURUNO products have a battery(ies). To see if your product has a battery(ies), see the chapter on Maintenance. Follow the instructions below if a battery(ies) is used. Tape the + and - terminals of battery before disposal to prevent fire, heat generation caused by short circuit.

In the European Union

The crossed-out trash can symbol indicates that all types of batteries must not be discarded in standard trash, or at a trash site. Take the used batteries to a battery collection site according to your national legislation and the Batteries Directive 2006/66/EU.

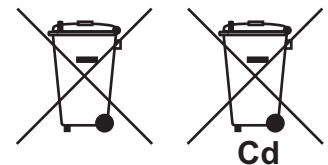

In the USA

The Mobius loop symbol (three chasing arrows) indicates that Ni-Cd and lead-acid rechargeable batteries must be recycled. Take the used batteries to a battery collection site according to local laws.

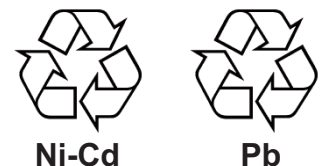

In the other countries

There are no international standards for the battery recycle symbol. The number of symbols can increase when the other countries make their own recycle symbols in the future.



SAFETY INSTRUCTIONS



WARNING

Indicates a condition that can cause death or serious injury if not avoided.



CAUTION

Indicates a condition that can cause minor or moderate injury if not avoided.

Safety Instructions for the Operator



WARNING



Do not disassemble or modify the equipment.

Fire, electrical shock or serious injury can occur.



Turn off the power immediately if water leaks into the equipment or smoke or fire is coming from the equipment.

Failure to turn off the equipment can cause fire or electrical shock. Contact a FURUNO agent for service.



CAUTION



The glass of an LCD panel breaks easily. Handle the LCD carefully.

Injury can result if the glass breaks.



No single navigation aid (including this unit) should ever be relied upon as the exclusive means for navigating your vessel.



The navigator is responsible for checking all aids available to confirm his position. Electronic aids are intended to assist, not replace, the navigator.

Safety Instructions for the Installer



WARNING



Turn off the power at the switchboard before you install the equipment.

Fire or electrical shock can occur if the power is left on.



Be sure that the power supply is compatible with the voltage rating of the equipment.

Connection of an incorrect power supply can cause fire or equipment damage. The voltage rating of the equipment appears on the label above the power connector.



CAUTION



Ground the equipment to prevent mutual interference.

Observe the following compass safe distances to prevent interference to a magnetic compass:

Model	Standard compass	Steering compass
GP-33	0.65 m	0.45 m

TABLE OF CONTENTS

FOREWORD	v
SYSTEM CONFIGURATION	vi
1. OPERATIONAL OVERVIEW	1-1
1.1 Controls	1-1
1.2 How to Turn Power On/Off	1-2
1.3 How to Adjust LCD and Key Panel Brilliance	1-3
1.4 Display Modes	1-3
1.5 Menu Overview.....	1-8
1.6 How to Enter the MOB Mark.....	1-9
2. PLOTTER DISPLAY OVERVIEW	2-1
2.1 How to Select the Display Range	2-1
2.2 How to Shift the Cursor	2-1
2.3 How to Shift the Display	2-2
2.4 How to Display/Hide Track and COG Line	2-2
2.5 How to Change Track Plotting Interval, Stop Recording	2-3
2.6 How to Change Track Color	2-4
2.7 How to Erase Track	2-4
2.7.1 How to erase track by color	2-4
2.7.2 How to erase all tracks	2-5
3. WAYPOINTS	3-1
3.1 How to Enter Waypoints	3-1
3.1.1 How to enter a waypoint with the cursor	3-1
3.1.2 How to enter a waypoint at own boat position	3-1
3.1.3 How to enter a waypoint through the list	3-1
3.1.4 How to enter waypoints automatically	3-3
3.2 How to Display Waypoint Name	3-4
3.3 How to Edit Waypoints	3-5
3.3.1 How to edit waypoints on the plotter display	3-5
3.3.2 How to edit waypoints through the list	3-5
3.4 How to Move Waypoints.....	3-6
3.5 How to Erase Waypoints	3-7
3.5.1 How to erase a waypoint on the plotter display	3-7
3.5.2 How to erase a waypoint through the waypoint list	3-7
3.5.3 How to erase all waypoints.....	3-8
4. ROUTES	4-1
4.1 How to Create Routes	4-1
4.2 How to Edit Routes.....	4-3
4.2.1 How to replace a waypoint in a route	4-3
4.2.2 How to delete a waypoint from a route	4-3
4.2.3 How to insert a waypoint in a route	4-4
4.2.4 How to temporarily deselect a waypoint in a route	4-4
4.3 How to Erase a Route	4-5
4.3.1 How to erase a route through the route list	4-5
4.3.2 How to erase all routes.....	4-5

5. DESTINATION	5-1
5.1 How to Set Destination by Cursor Position	5-1
5.2 How to Set Destination by Waypoint.....	5-2
5.2.1 How to set a destination waypoint with the cursor	5-2
5.2.2 How to set a destination waypoint through the list.....	5-2
5.3 How to Set Route as Destination	5-2
5.4 How to Cancel Destination.....	5-3
5.4.1 How to cancel destination with the cursor.....	5-3
5.4.2 How to cancel destination through the list.....	5-4
6. ALARMS	6-1
6.1 Overview	6-1
6.2 Buzzer Type Selection	6-2
6.3 How to Set an Alarm	6-2
6.4 Alarm Descriptions	6-4
7. OTHER FUNCTIONS	7-1
7.1 Plotter Setup Menu	7-1
7.2 GPS Setup Menu	7-2
7.3 WAAS/DGPS Menu	7-4
7.4 Position Display Format	7-5
7.5 System Menu	7-6
7.6 User Display Menu.....	7-8
7.7 I/O Setup Menu	7-11
7.7.1 Uploading data to a PC.....	7-13
7.7.2 Downloading data from PC.....	7-13
8. MAINTENANCE, TROUBLESHOOTING.....	8-1
8.1 Maintenance.....	8-1
8.2 Troubleshooting	8-2
8.3 Displaying the Message Board	8-3
8.4 Diagnostics.....	8-3
8.5 Clearing Data	8-4
9. INSTALLATION	9-1
9.1 Equipment Lists.....	9-1
9.2 Installation of Receiver Unit	9-1
9.2.1 Installation consideration.....	9-1
9.2.2 Desktop and underside of table mount	9-2
9.2.3 Flush mount	9-3
9.3 Installation of Antenna Unit	9-4
9.4 Wiring.....	9-5
9.5 Language Setting	9-8
9.6 Input/Output Data.....	9-8
APPENDIX 1 MENU TREE	AP-1
APPENDIX 2 WHAT IS WAAS?	AP-3
APPENDIX 3 LIST OF TERMS	AP-4
APPENDIX 4 GEODETIC CHART LIST	AP-5
SPECIFICATIONS	SP-1
INSTALLATION MATERIALS, ACCESSORIES	A-1
OUTLINE DRAWINGS.....	D-1
INTERCONNECTION DIAGRAM	S-1
INDEX.....	IN-1

FOREWORD

A Word to the Owner of the GP-33

Congratulations on your choice of the GP-33 GPS Navigator.

Since 1948, FURUNO Electric Company has enjoyed an enviable reputation for innovative and dependable marine electronics is furthered by our extensive global network of agents and dealers.

Your navigator is designed and constructed to meet the rigorous demands of the marine environment. However, no machine can perform its intended function unless installed, operated and maintained properly. Please carefully read and follow the recommended procedures for installation, operation and maintenance.

We would appreciate feedback from you, the end-user, about where we are achieving our purposes.

Thank you for considering and purchasing FURUNO equipment.

Features

The main features of the GP-33 are as shown below.

- High-resolution color LCD
- A DGPS beacon receiver can be connected to the GP-33 to add DGPS capability.
- WAAS capability
- Storage for 10,000 waypoints, 100 routes and 3,000 track points
- Alarms: Arrival/Anchor, XTE (Cross-track Error), Trip, Odometer, Time, WAAS/DGPS and Speed
- Man overboard feature records position at time of man overboard and provides continuous updates of range and bearing when navigating to the MOB position.
- Unique Highway display provides a graphic presentation of boat's progress toward a waypoint.
- User-programmable nav data displays provide analog and digital navigation data.
- Navigation data output to the autopilot when connecting.
- Waypoint and route data can be uploaded from a PC and downloaded to a PC.

Program No.

Name	No.	Ver.
CPU MAIN	2051530-02.**	March, 2013
CPU Boot	2051531-01.**	January, 2010
CPU CAN LD	2051532-01.**	January, 2010
GPS	48502640-.**	January, 2010

** : Minor change

With regards to CE declarations, please refer to our website (www.furuno.com), for further information on RoHS conformity declarations.

SYSTEM CONFIGURATION

Standalone system

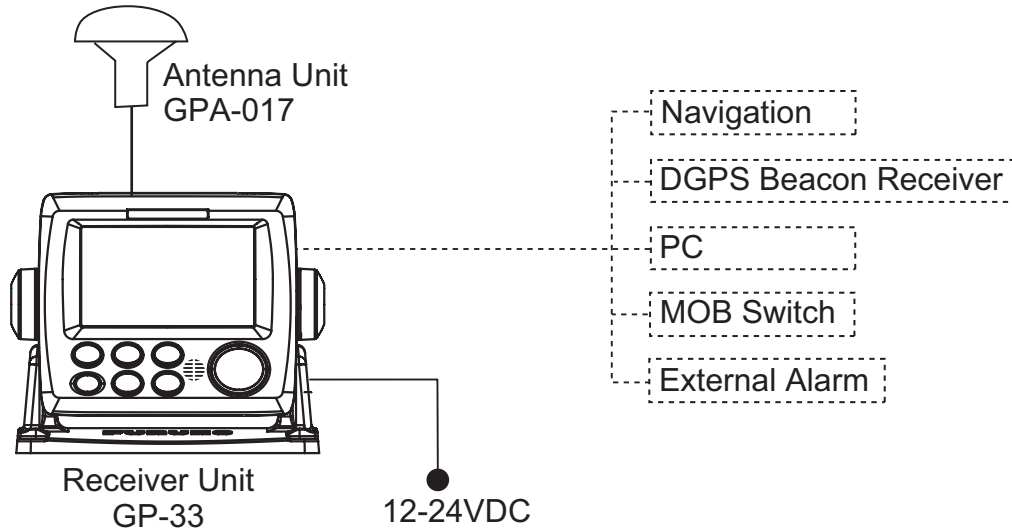

Standard configuration is shown with solid line.

CAN bus network

When optional junction box FI-5002 is connected

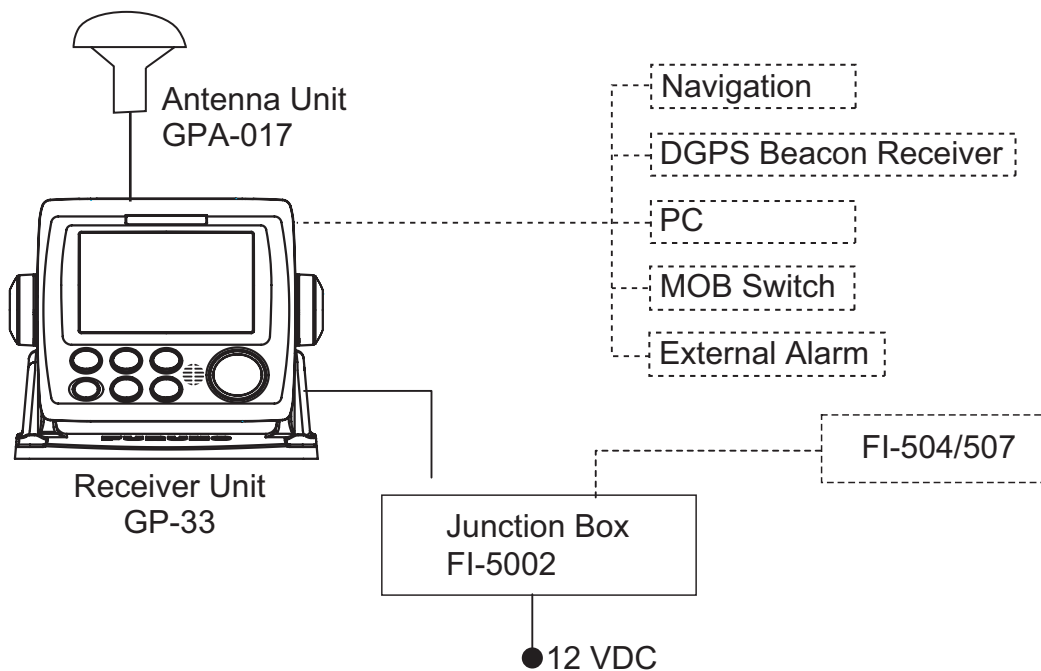

When no FI-5002 is connected

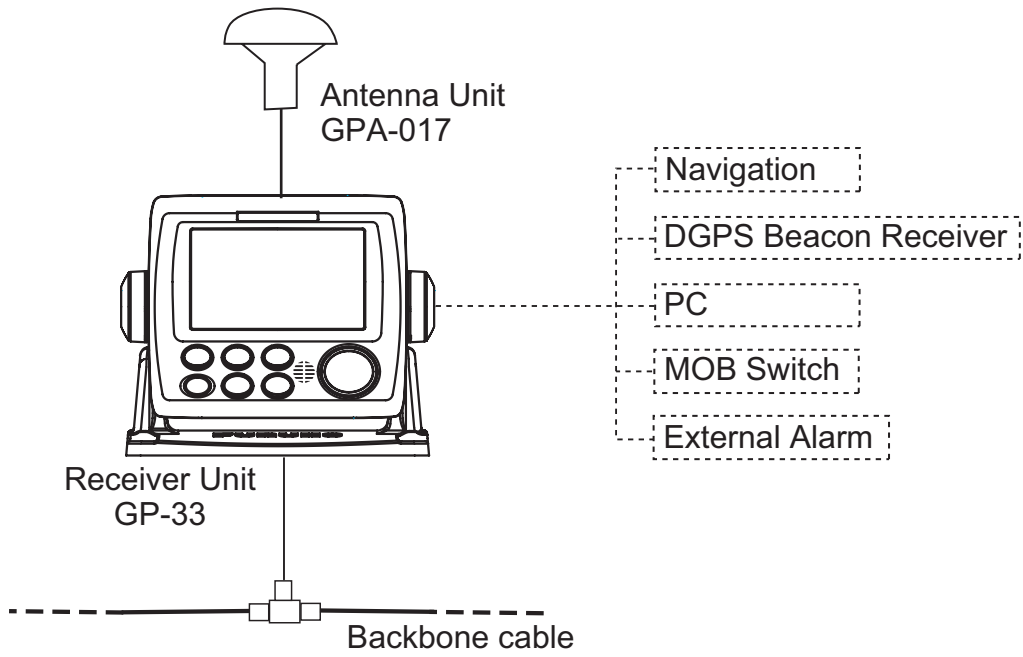

Category of Units







Units	Category
Antenna Unit GPA-017	Exposed to weather
Receiver Unit GP-33	Protected from weather
Junction Box FI-5002 (Option)	

This page is intentionally left blank.

1. OPERATIONAL OVERVIEW

1.1 Controls



Key	Description
	Selects display mode.
	Sets destination.
	-Opens the Menu. (plotter and highway displays: twice, others: once) -Shows the zoom window (plotter and highway displays only).
 (Cursorpad)	-Shifts the cursor. -Selects item on menus.
	-Long press: Turns power off. -Momentary press: Turns power on./Shows Brill window.
	-Long press: Inscribes MOB mark. -Momentary press: Registers own boat position as waypoint.
	-Long press: Returns own boat position to center (plotter display only). -Momentary press: Confirms selection on menus.

How to detach the hard cover from the unit

Put your thumbs on the front and forefingers on the catches at the sides of the cover, and pull it toward you.

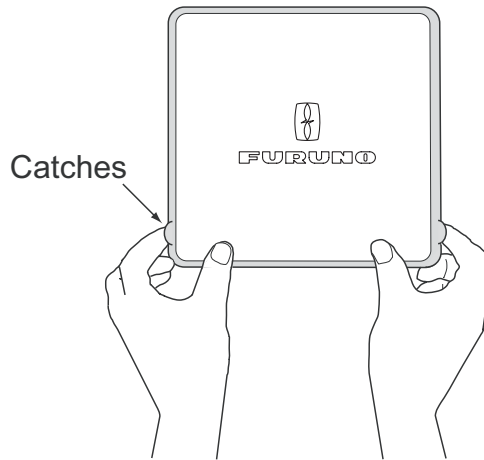

1.2 How to Turn Power On/Off

1. Press the  /**BRILL** key to turn on the power. The unit beeps and then starts up with the last-used display mode. Your equipment takes about 90 seconds to find its position. The equipment shows receiver status indication at the top left-hand corner in most display modes. The table below shows these indications and their meanings.

Status indications

Indication	Meaning
2D	2D GPS position fixed
3D	3D GPS position fixed
D2D	2D DGPS position fixed
D3D	3D DGPS position fixed
W2D	2D WAAS position fixed
W3D	3D WAAS position fixed
DOP*	2D: HDOP larger than 4 3D: PDOP larger than 6
SIM	Simulation mode
- - -	Not fixed

*: DOP (Dilution of Precision) is the index of position accuracy, and it is the distribution pattern of satellites used in position fixing. Generally, the smaller the figure the better the position accuracy. (HDOP: Horizontal DOP, PDOP: Position DOP)

2. To turn off the power, press and hold down the  /**BRILL** key for three seconds. The time remaining until the power is turned off is counted down on the display.

Note: The screen refreshes slower in low ambient temperature.

1.3 How to Adjust LCD and Key Panel Brilliance

1. Press the  /BRILL key to show the following window.

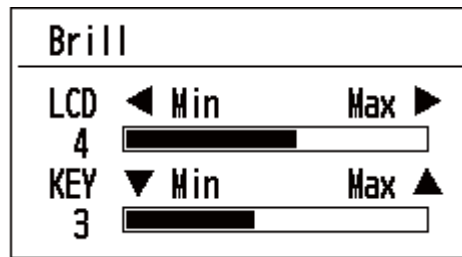

2. To adjust the LCD brilliance, press  /BRILL key. The setting changes “0→1→...→7→6...0→1...” continuously. Maximum setting is 7. You can use also the cursorpad (◀, ▶) to adjust the brilliance.
3. To adjust the panel brilliance, press the cursorpad (▲, ▼, max: 7).
4. Press **ENT** or **MENU/ZOOM** key.

1.4 Display Modes

Your unit has seven display modes: Plotter Display, Highway Display, Steering Display, Nav Data Display, Satellite Monitor Display and User Display 1/2. Press the **DISP** key to select a display mode. Each time the key is pressed, the display mode changes in the sequence shown below. To step through the displays in reverse order, press the **DISP** key more than three seconds.

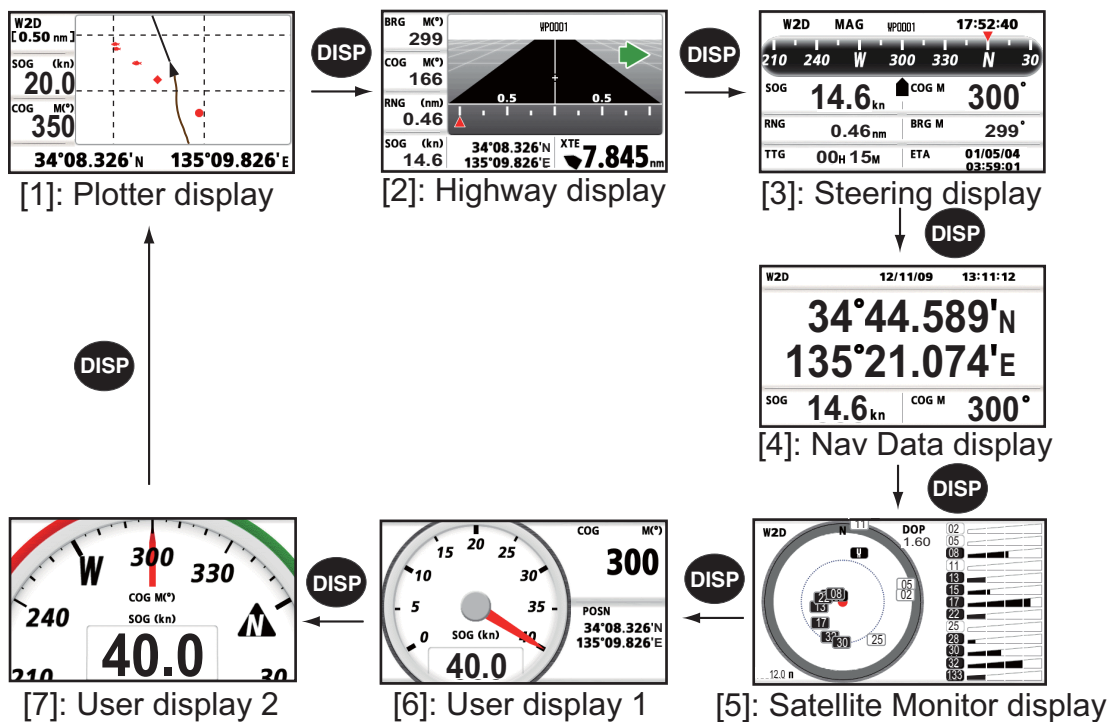

1. OPERATIONAL OVERVIEW

Plotter Display

The plotter display traces own boat's track.

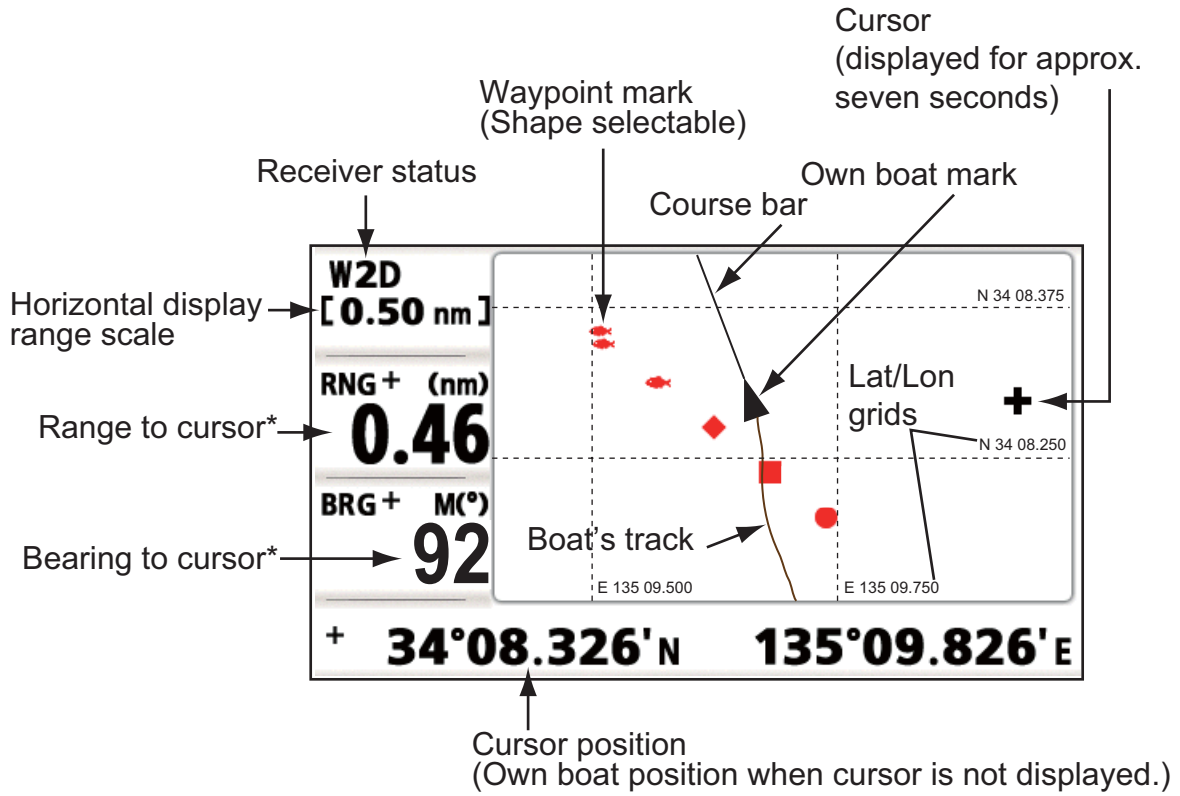

*:COG and SOG replace bearing to cursor and range to cursor when the cursor is not displayed.

Highway Display

The highway display provides a 3-D view of own boat's progress toward destination.

XTE (Cross-track error) scale and arrow mark
 Arrow shifts with boat's XTE. When the arrow is aligned with the center line the boat is on course. The arrow blinks if boat's XTE is greater than XTE scale range.

"N (North)" is displayed, instead of the arrow, at the center of the scale when no destination is set.

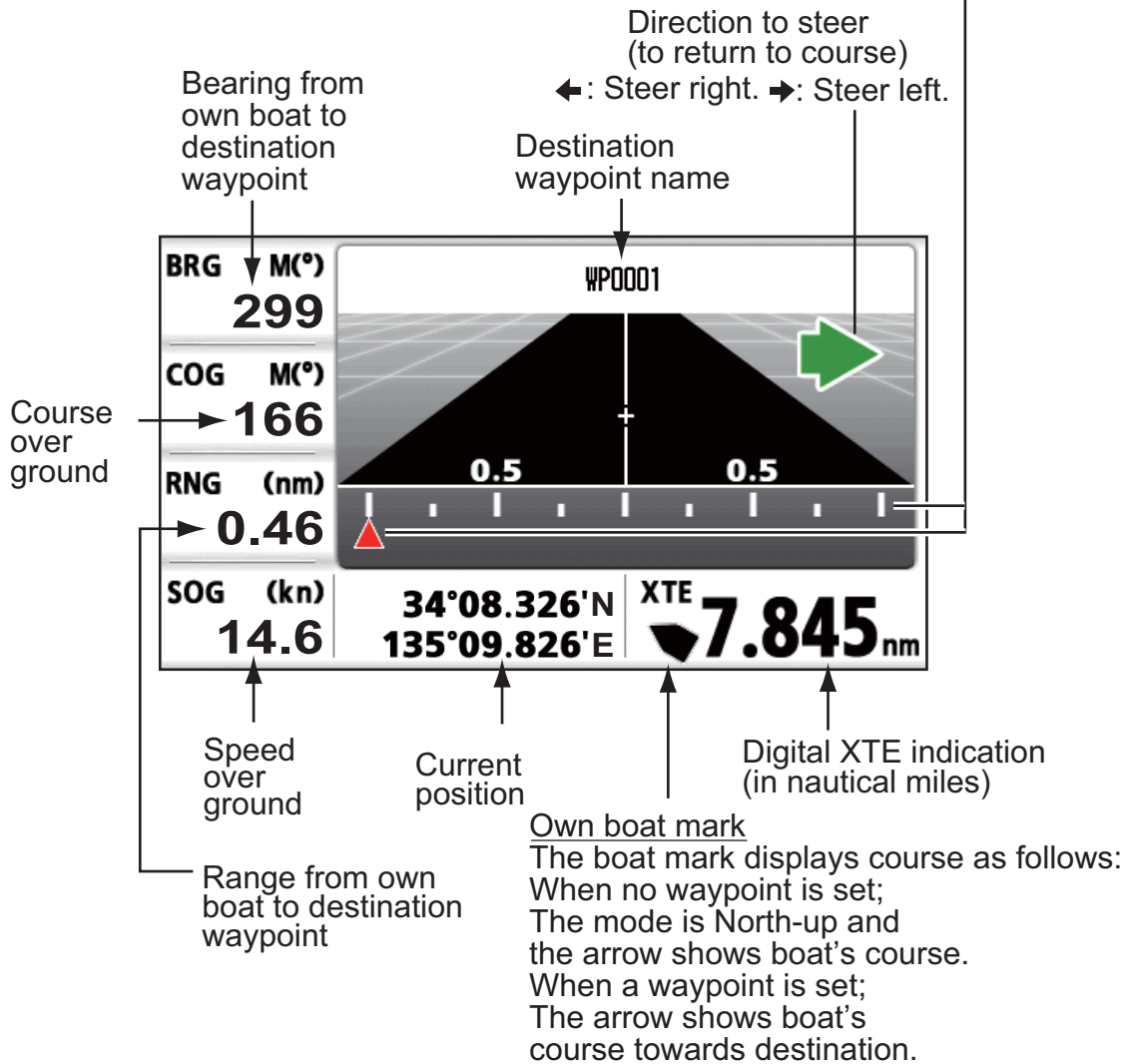

1. OPERATIONAL OVERVIEW

Steering Display

The steering display provides steering information.

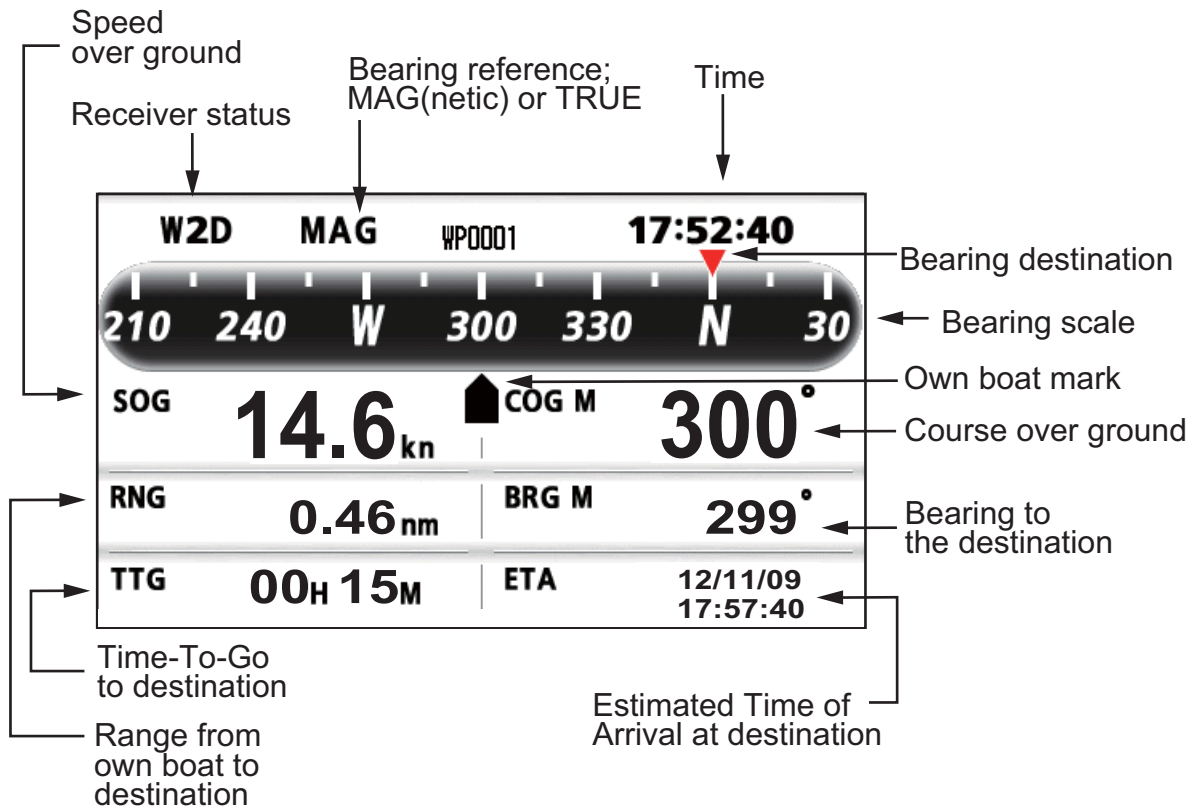

Nav Data Display

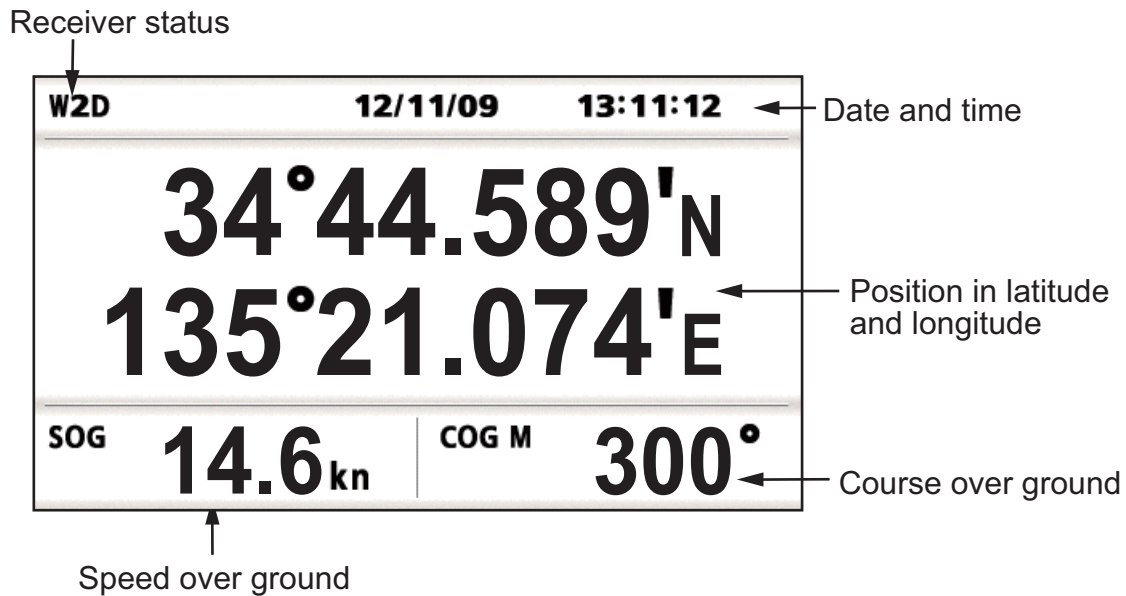

Satellite Monitor Display

The satellite monitor display shows the condition of GPS and GEO (WAAS) satellites. Number, bearing and elevation angle of all GPS and GEO satellites (if applicable) in view of your receiver appear.

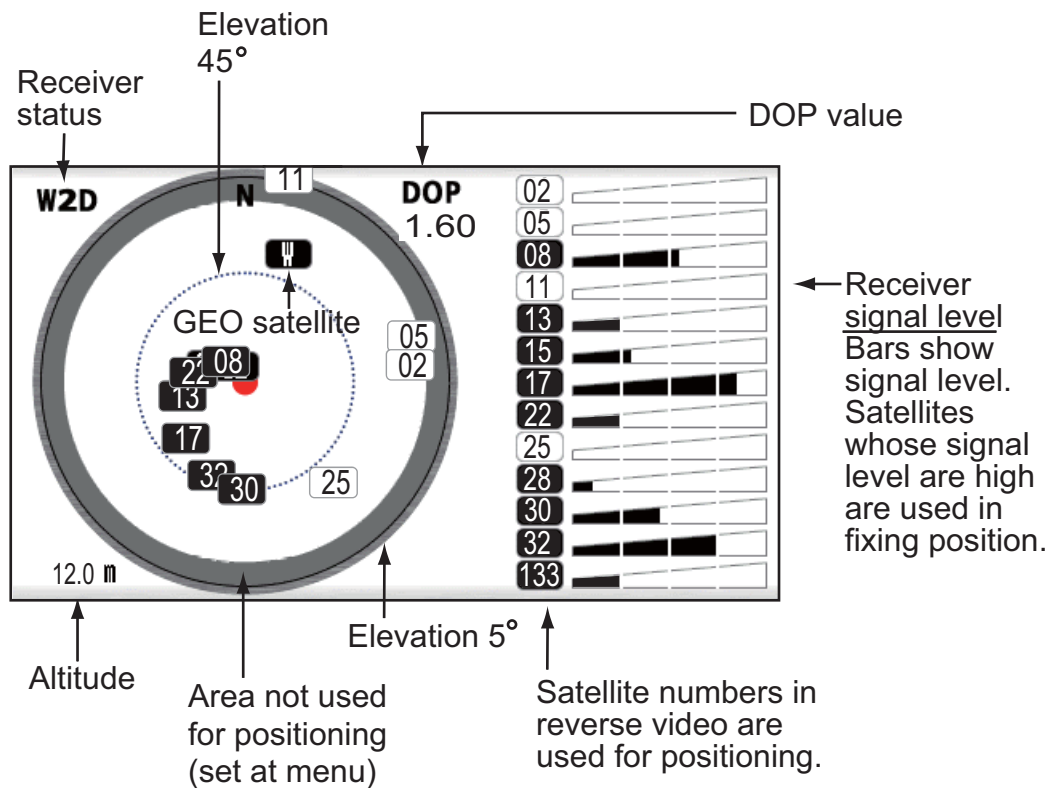

User Display 1, User Display 2

- Digital display
The digital display shows digital navigation data. You can select what data to display in one to four cells. The choices of data are time, date, speed over ground, cross-track-error, odometer distance, position, course over ground, time-to-go to destination, trip distance, power source voltage, range and bearing to waypoint and estimated time of arrival at destination.
- Speedometer display
The speedometer display provides both digital and analog displays of speed over ground.
- COG display
The COG display shows both analog course over ground, and digital speed over ground.

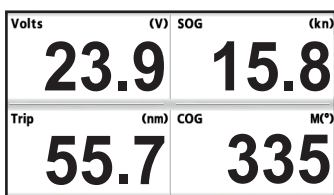

Digital display (four cells)

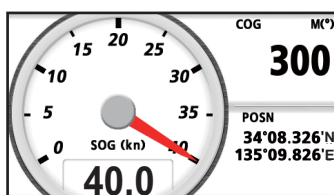

Speedometer display (default: User display 1)



COG display (default: User display 2)

1.5 Menu Overview

Most operations of your unit are done through the menu. Below is a quick introduction to how to select a menu and change menu settings. If you get lost in operation, press the **MENU/ZOOM** key to return to the main menu.

1. Press the **MENU/ZOOM** key once or twice to display the main menu.
 Press once: Steering display, nav data display, satellite monitor display, user display 1/2.
 Press twice: Plotter display, highway display

Note: Following explanation takes the menus for the plotter display as an example.

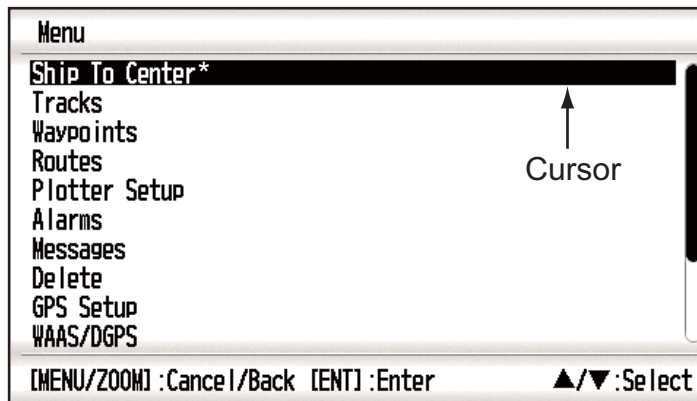

*: Shown only when the MENU/ZOOM key is pressed at the plotter display.

2. Press ▲ or ▼ to select an item, and press the **ENT** key.
3. Press **ENT** (or ►) key.
 For example, select [Plotter Setup] and press the **ENT** key.

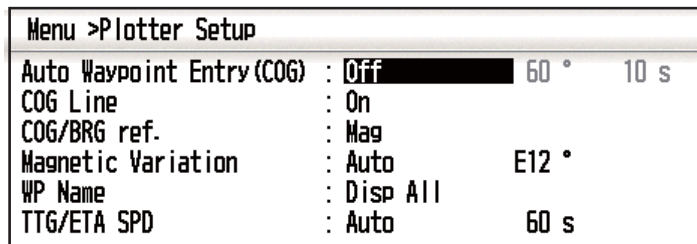

4. Press ▲ or ▼ to select option desired.
 For example, select [COG/BRG ref.]
5. Press the **ENT** key (or ►).
 A window shows the options for the item selected.

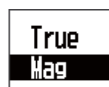

6. Press ▲ or ▼ to select option desired.
7. Press the **ENT** key (or ►).
8. Press the **MENU/ZOOM** key (or ◀) twice to close the menu.

How to enter alphanumeric data

Some menu operations require you to enter alphanumeric data (A to Z, 0 to 9) and symbols (&, _, #, ' , - , > and space). The procedure which follows shows how to enter alphanumeric data. For example, to change the waypoint name "WP0006" to "KOB", do the follows:

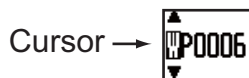

- 1) Press ▲ or ▼ to select "K".
- 2) Press ►, and press ▲ or ▼ to select "O".
- 3) Press ►, and press ▲ or ▼ to select "B".
- 4) Press ►, and press ▲ or ▼ to select "E".
- 5) Press ►, and press ▲ or ▼ to select " "(space).
- 6) Press ►, and press ▲ or ▼ to select " " (space).
- 7) Press the **ENT** key.

1.6 How to Enter the MOB Mark

The MOB mark denotes man overboard position. Only one MOB mark is displayed. Each time the MOB mark is entered the previous MOB mark and its position data are overwritten.

1. Press and hold the **WPT/MOB** key down to show the following message.

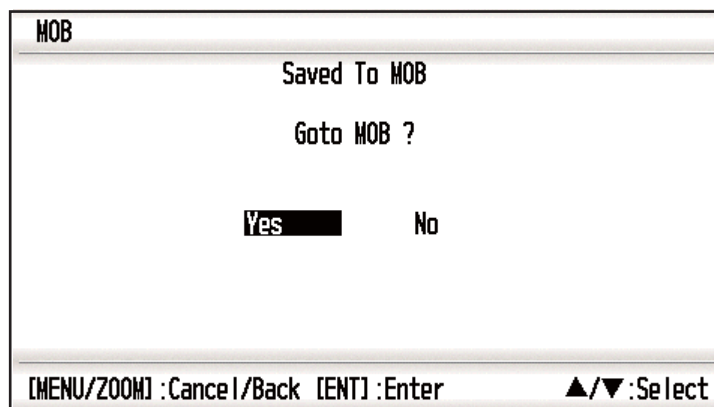

2. To set MOB position as destination, confirm that [Yes] is chosen and press the **ENT** key. MOB mark ("M") appears and a blue line is drawn between own boat mark and the MOB mark. This line shows the shortest course to go to the MOB position, and arrows on the line show the direction to the MOB position.

1. OPERATIONAL OVERVIEW

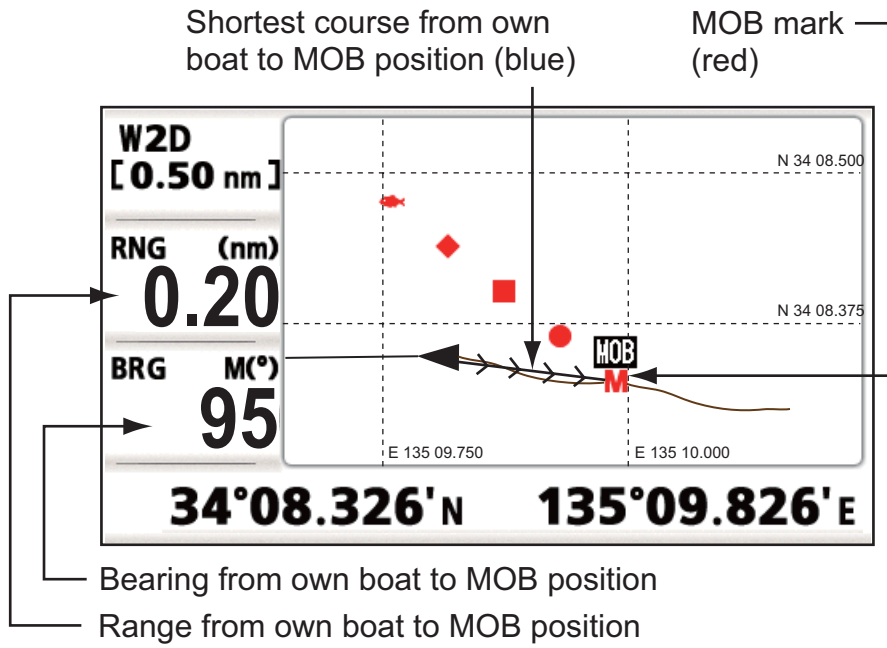

2. PLOTTER DISPLAY OVERVIEW

2.1 How to Select the Display Range

You can change the display range on the plotter and highway displays. The horizontal range in the plotter display is available among 0.02, 0.05, 0.1, 0.2, 0.5, 1, 2, 5, 10, 20, 40, 80, 160 and 320 nautical miles. The horizontal range in the highway display is available among 0.2, 0.4, 0.8, 1, 2, 4, 8 and 16 nautical miles.

1. Press the **MENU/ZOOM** key on the plotter or highway display.
The following window appears.

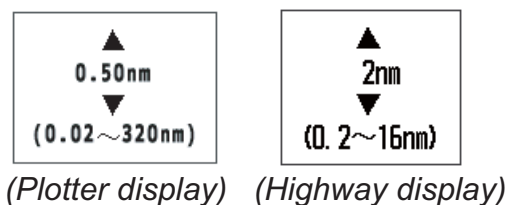

2. Press **▲** or **▼** to select range you want.
3. Press the **ENT** key.

2.2 How to Shift the Cursor

Use the cursorpad to shift the cursor. The cursor moves in the direction of the arrow or diagonal.

Cursor state and position indication

The position indication, shown at bottom of the plotter display, changes according to cursor state.

Cursor at rest

When the cursor is not shown, boat's position in longitude and latitude or TDs (depending on the menu setting) appears at the bottom of the display.

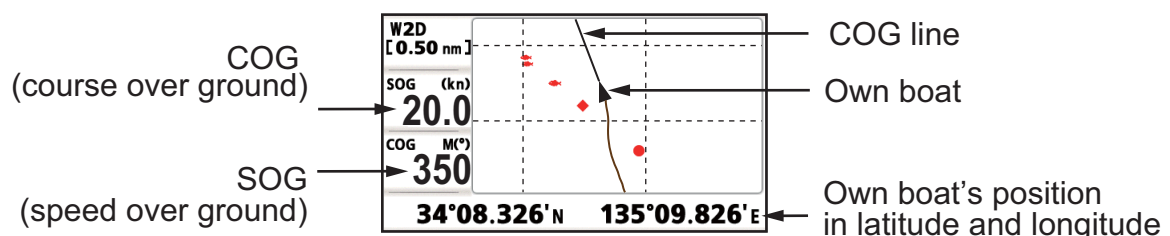

2. PLOTTER DISPLAY OVERVIEW

Cursor state and position indication

Cursor position is displayed in latitude and longitude or TDs at the bottom of the plotter display when the cursor is shown.

If there is no operation for about seven seconds, the cursor disappears.

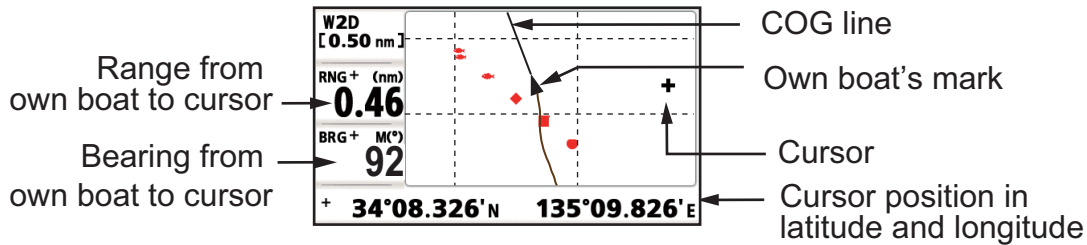

2.3 How to Shift the Display

The display can be shifted on the plotter display.

1. Press the cursorpad to show the cursor.
2. Press and hold down an arrow on the cursorpad.
When the cursor is placed at an edge of the screen, the display shifts in the direction opposite to cursorpad operation.

Centering own boat's position

When own boat tracks off the plotter display, the own boat mark is automatically returned to the screen center. You can also return it manually by pressing and holding the **ENT** key for more than three seconds.

2.4 How to Display/Hide Track and COG Line

The own boat's track and COG line can be displayed or hidden separately on the plotter display.

1. Press the cursorpad to show the cursor.
2. Operate the cursorpad to place the cursor on the own boat mark.
3. Press the **ENT** key to show the pop-up window.
The default setting is On for Track and COG Line, so the following pop-up window for Off setting appears.

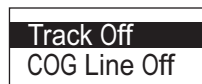

4. Select [Track Off] or [COG Line Off] to hide the track or COG line, and press the **ENT** key. To display the track or COG line, select [Track On] or [COG Line On] and press the **ENT** key.

2.5 How to Change Track Plotting Interval, Stop Recording

To trace the boat's track, the boat's position is stored into the memory at an interval of distance or according to display range. For distance, a shorter interval provides better reconstruction of the track, but the storage time of the track is shortened. When the track memory becomes full, the oldest track is erased to make room for the latest. The current percentage of the memory used can be confirmed by choosing [Tracks] on the menu.

1. Press the **MENU/ZOOM** key twice to show the main menu.
2. Select [Tracks], and press the **ENT** key.

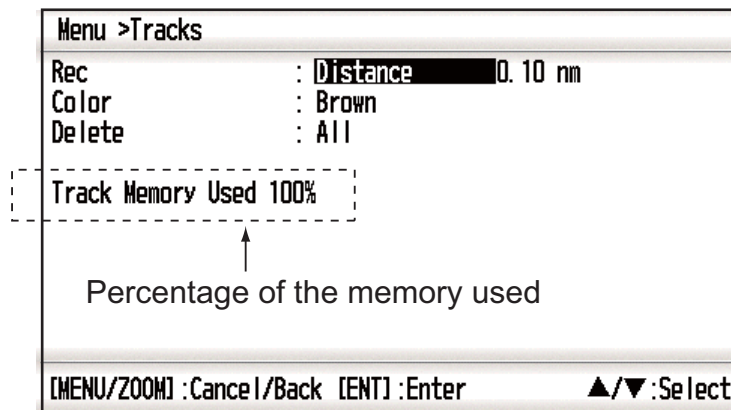

3. Confirm that the [Rec] is selected, and press the **ENT** key.

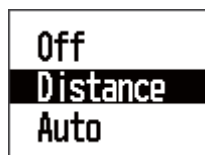

4. Select [Off], [Distance] or [Auto], and press the **ENT** key.
 - Off: Track is not recorded. This setting is useful when you do not need to record track.
 - Distance: Track is recorded and plotted at the distance interval set.
 - Auto: Plotting and recording interval changes with display range selected.
5. For [Off] or [Auto], go to step 6. For [Distance], enter the recording interval as follows:
 - 1) Press ►.
 - 2) Press **ENT** key.

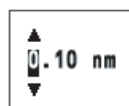

- 3) Use the cursorpad to enter the interval, and press the **ENT** key. For entering the numeric data, see page 1-9.
6. Press the **MENU/ZOOM** key twice to close the menu.

2.6 How to Change Track Color

You can select the color for the tracks among red, yellow, green, blue, purple, black and brown. It is useful to change the color to distinguish tracks at different times of a day, for example.

1. Press the **MENU/ZOOM** key twice to show the main menu.
2. Select [Tracks], and press the **ENT** key.
3. Select [Color], and press the **ENT** key.



4. Select the color to use for the track, and press the **ENT** key.
5. Press the **MENU/ZOOM** key twice to close the menu.

2.7 How to Erase Track

The tracks can be erased collectively or by color. The tracks cannot be restored once erased, therefore be absolutely sure you want to erase the tracks.

2.7.1 How to erase track by color

1. Press the **MENU/ZOOM** key twice to show the main menu.
2. Select [Tracks], and press the **ENT** key.
3. Select [Delete], and press the **ENT** key.



4. Select [By Color], and press the **ENT** key.



5. Select the track color to erase, and press the **ENT** key.
The window shown below appears.

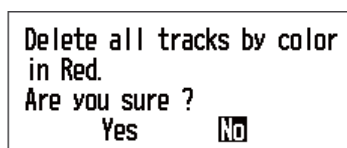

6. Press **◀** to select [Yes], and press the **ENT** key.
The tracks with the color chosen at step 5 are erased.

Note: To cancel, select [No] at this step.

7. Press the **MENU/ZOOM** key twice to close the menu.

2.7.2 How to erase all tracks

1. Press the **MENU/ZOOM** key twice to show the main menu.
2. Select [Tracks], and press the **ENT** key.
3. Select [Delete], and press the **ENT** key.
4. Select [All], and press the **ENT** key.

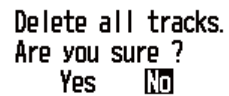

Delete all tracks.
Are you sure ?
Yes No

5. Press **◀** to select [Yes], and press the **ENT** key to erase all tracks.
[Track Memory Used] on the Tracks menu shows "0%".
6. Press the **MENU/ZOOM** key twice to close the menu.

2. PLOTTER DISPLAY OVERVIEW

This page is intentionally left blank.

3. WAYPOINTS

3.1 How to Enter Waypoints

In navigation terminology a waypoint is a particular location on a voyage, whether it be a starting, intermediate or destination waypoint. Your unit can store 10,000 waypoints. Waypoints can be entered on the plotter display: at cursor position, at own boat's position, through the waypoints list and at the MOB position. Also, waypoints can be entered automatically when your boat changes course prominently.

3.1.1 How to enter a waypoint with the cursor

1. Use the cursorpad to place the cursor on the location desired for a waypoint.
2. Press the **ENT** key to enter the waypoint mark (default shape: green solid circle). This waypoint is named with the youngest unused waypoint number, and saved to the waypoint list.

3.1.2 How to enter a waypoint at own boat position

Press the **WPT/MOB** key to enter the waypoint mark (default shape: green solid circle). This waypoint is named with the youngest unused waypoint number, and saved to the waypoint list.

3.1.3 How to enter a waypoint through the list

1. Press the **MENU/ZOOM** key to show the main menu.
2. Select [Waypoints], and press the **ENT** key.



3. Press the **ENT** key to show the waypoint list.

Menu >Waypoints >Waypoint List				
Name	Symbol	Color	RNG (nm)	BRG (°)
[New]				
G WPO001	●	Red	115	115
WPO002	■	Red	116	116
WPO003	◆	Red	117	117
WPO004	⦿	Red	118	118
WPO005	⦿	Red	119	119

[MENU/ZOOM] :Cancel/Back [ENT] :Enter ▲/▼ :Select

3. WAYPOINTS

4. Confirm that [New] is chosen, and press the **ENT** key.

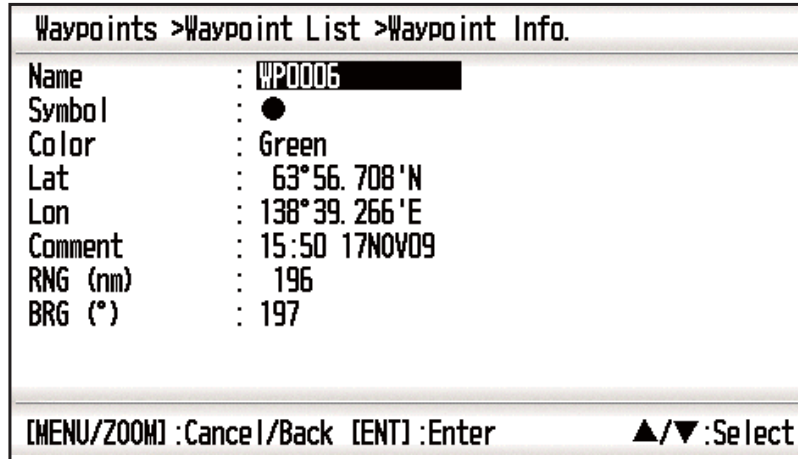

The default name, Lat/Lon and Comment are as follows:

Name: The youngest unused waypoint number.

Lat, Lon: Current own boat position

Comment: Current date/time

5. To change the waypoint name, press the **ENT** key.

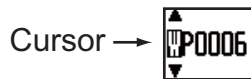

6. Operate the cursorpad to change the waypoint name (max. 8 characters).
7. To change the mark shape, select [Symbol] and press the **ENT** key.



8. Select a mark desired, and press the **ENT** key.
9. To change the mark color, select [Color], and press the **ENT** key.



10. Select a color desired, and press the **ENT** key.
11. To change the position, do as follows:
 - 1) Select [Lat], and press the **ENT** key.
 - 2) Enter latitude, and press the **ENT** key.
 - 3) Press ▼ to select [Lon], and press the **ENT** key.
 - 4) Enter longitude, and press the **ENT** key.

12. To change the comment, select [Comment] and press the **ENT** key.
13. Enter the comment, and press the **ENT** key.
14. Press the **MENU/ZOOM** key to register the new waypoint into the list.
15. To register other waypoints, repeat steps 4 through 14.
16. Press the **MENU/ZOOM** key several times to close the menu.

3.1.4 How to enter waypoints automatically

Waypoints can be entered automatically when your course changes by a specified degree. This function is useful for reversely following the waypoints recorded on an outward voyage when you return home. To set the criteria for automatic entering of waypoints, do the following:

1. Press the **MENU/ZOOM** key twice to show the main menu.
2. Select [Plotter Setup], and press the **ENT** key.

Menu >Plotter Setup			
Auto Waypoint Entry (COG)	: Off	60 °	10 s
COG Line	: On		
COG/BRG ref.	: Mag		
Magnetic Variation	: Auto	E12 °	
WP Name	: Disp All		
TTG/ETA SPD	: Auto	60 s	

3. Select [Auto Waypoint Entry (COG)], and press the **ENT** key.
4. Select [On], and press the **ENT** key.
5. Press **▶** to select the degree setting, and press the **ENT** key.
6. Enter the degree, and press the **ENT** key (setting range: 15 to 150°).
7. Press **▶** to select the seconds setting, and press the **ENT** key.
8. Enter the seconds, and press the **ENT** key (setting range: 1 to 60 seconds).
9. Press the **MENU/ZOOM** key twice to close the menu.

3.2 How to Display Waypoint Name

You can display waypoint names as follows:

1. Press the **MENU/ZOOM** key twice to show the main menu.
2. Select [Plotter Setup], and press the **ENT** key.

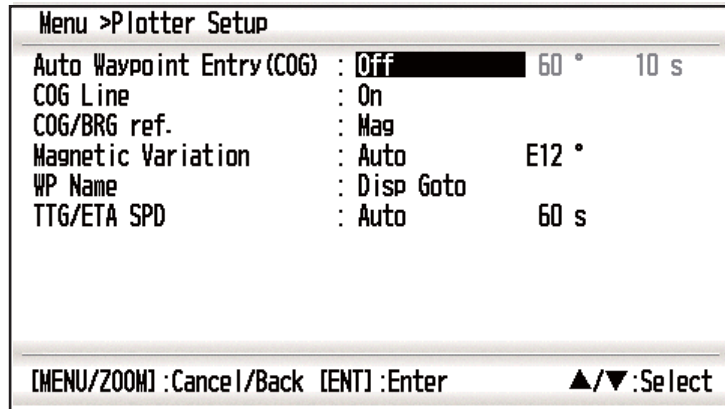

3. Select [WP Name], and press the **ENT** key.

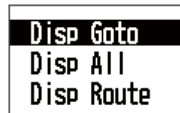

4. Select [Disp Goto], [Disp All] or [Disp Route], and press the **ENT** key.
 Disp Goto: Displays only the destination waypoint name.
 Disp All: Displays all waypoint names.
 Disp Route: Displays all waypoint names in the route when it is set as destination.
5. Press the **MENU/ZOOM** key twice to close the menu.

3.3 How to Edit Waypoints

Waypoint position, name, mark shape and comment can be edited on the plotter display or through the waypoint list.

Note: When the waypoint chosen is set as the destination, the message "Change The Waypoint. Are you sure?" appears.

3.3.1 How to edit waypoints on the plotter display

1. Operate the cursorpad to place the cursor on the waypoint to edit.
2. Press the **ENT** key to show the pop-up window.



3. Select [Edit], and press the **ENT** key to show the waypoint information.
4. Edit the waypoint (see the paragraph 3.1.3).
5. Press the **MENU/ZOOM** key to return to the plotter display.

3.3.2 How to edit waypoints through the list

1. Press the **MENU/ZOOM** key twice to show the main menu.
2. Select [Waypoints], and press the **ENT** key.
3. Select [Alpha] or [Local], and press the **ENT** key.
Alpha: The list shows waypoints in alphabetical order.
Local: The list shows waypoints from the nearest to the furthest.
4. Select the waypoint to edit, and press the **ENT** key to show the pop-up window.



5. Select [Edit], and press the **ENT** key to show the waypoint information.
6. Edit the waypoint data (see the paragraph 3.1.3).
7. Press the **MENU/ZOOM** key several times to close the menu.

3.4 How to Move Waypoints

You can move waypoints to any position on the plotter display.

1. Operate the cursorpad to place the cursor on the waypoint to move.
2. Press the **ENT** key to show the pop-up window.



3. Select [Move], and press the **ENT** key to show the waypoint information.
4. Operate the cursorpad to move the cursor to the new position.
5. Press the **ENT** key.

3.5 How to Erase Waypoints

You can erase each or all waypoint(s).

Note: You cannot erase the waypoint used as the current destination. (See paragraphs paragraph 3.5.1, paragraph 3.5.2.)

3.5.1 How to erase a waypoint on the plotter display

1. Operate the cursorpad to place the cursor on the waypoint to erase.
2. Press the **ENT** key to show the pop-up window.



3. Select [Delete], and press the **ENT** key.

3.5.2 How to erase a waypoint through the waypoint list

1. Press the **MENU/ZOOM** key twice to show the main menu.
2. Select [Waypoints], and press the **ENT** key.
3. Select [Alpha] or [Local], and press the **ENT** key.
4. Select the waypoint to erase, and press the **ENT** key.



5. Select [Delete], and press the **ENT** key.
6. Press the **MENU/ZOOM** key several times to close the menu.

3.5.3 How to erase all waypoints

1. Press the **MENU/ZOOM** key twice to show the main menu.
2. Select [Delete], and press the **ENT** key.

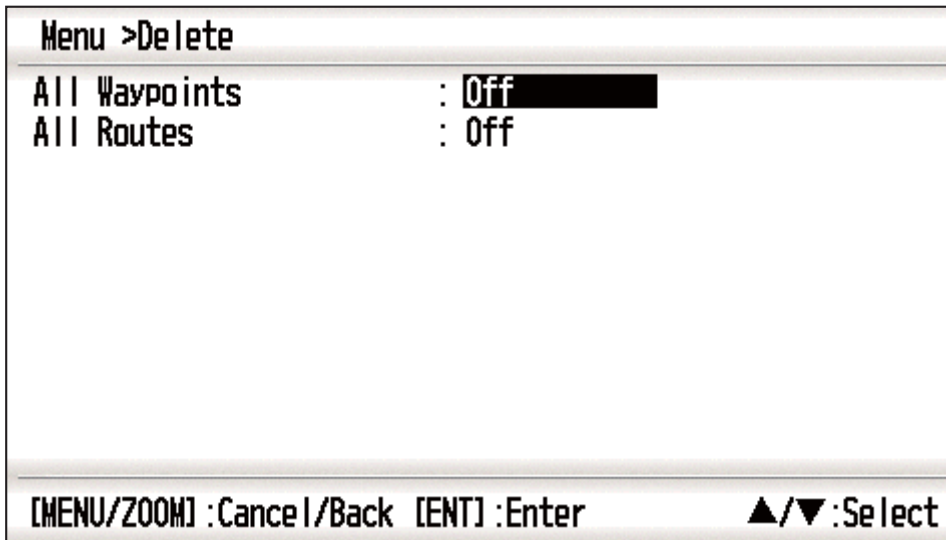

3. Confirm that [All Waypoints] is chosen, and press the **ENT** key.



4. Select [Delete], and press the **ENT** key.

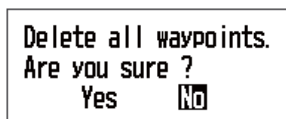

When no waypoint is set as destination

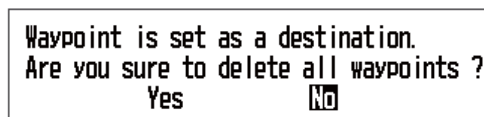

When a waypoint is set as destination

5. Select [Yes], and press the **ENT** key to erase all waypoints.
Note: To cancel, select [No].
6. Press the **MENU/ZOOM** key twice to close the menu.

4. ROUTES

In many cases a trip from one place to another involves several course changes, requiring a series of waypoints which you navigate to, one after another. The sequence of waypoints leading to the ultimate destination is called a route. Your unit can automatically advance to the next waypoint on a route, so you do not have to change the destination waypoint repeatedly.

4.1 How to Create Routes

You can store up to 100 routes, and a route can have 30 waypoints. A route is constructed with the waypoints you have entered.

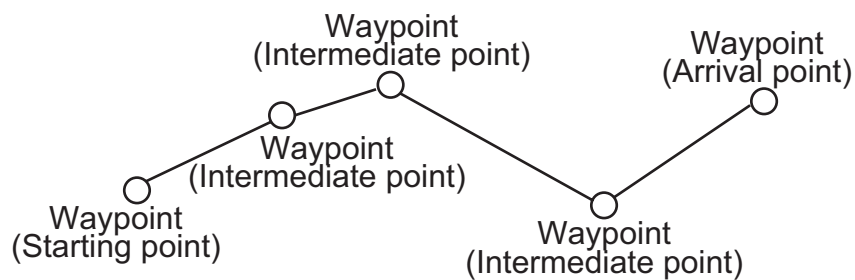

Sample route

1. Press the **MENU/ZOOM** key twice to show the main menu.
2. Select [Routes], and press the **ENT** key.
3. Press the **ENT** key to show the route list.

Menu >Routes >Route List		
Name	TLEG (nm)	Number
[New]		

[MENU/ZOOM] :Cancel/Back [ENT] :Enter ▲/▼ :Select

4. ROUTES

- Confirm that [New] is chosen, and press the **ENT** key to show the route information.

Routes >Route List >Route Info.				
Name	:	RT0001	Total	LEG 0.00nm 0 Points
Cmnt	:	->	LEG	BRG
1	:			
2	:		nm	
3	:		nm	
4	:		nm	
5	:		nm	
6	:		nm	
7	:		nm	
8	:		nm	

[MENU/ZOOM] :Cancel/Back [ENT] :Enter ▲/▼:Select

- Press the **ENT** key to change the route name.



- Operate the cursorpad to enter the route name, and press the **ENT** key (maximum: six characters).
- Press ▼ then **ENT** key.

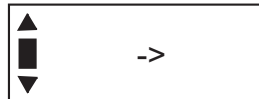

- Operate the cursorpad to enter the comment (maximum: 18 characters).
- Press ▼ to move the cursor to [1], and press the **ENT** key.

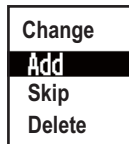

- Confirm that [Add] is chosen, and press the **ENT** key.
- Select [Alpha] or [Local], and press the **ENT** key to show the waypoint list.
- Select the waypoint to add to the route, and press the **ENT** key.
The chosen waypoint (as the starting point) is registered to [1].
- Press ▼ to select [2], and press the **ENT** key.
- Repeat steps 10 through 13 to complete the route.
- Press the **MENU/ZOOM** key several times to close the menu.

4.2 How to Edit Routes

You can edit the route created.

Note: When the route chosen is set as route navigation, the message "Route is set as a destination. Are you sure?" appears.

4.2.1 How to replace a waypoint in a route

1. Press the **MENU/ZOOM** key twice to show the main menu.
2. Select [Routes], and press the **ENT** key.
3. Select [Alpha] or [Local], and press the **ENT** key to show the route list.
4. Select the route to edit, and press the **ENT** key.



5. Select [Edit], and press the **ENT** key to show the route list.
6. Select the waypoint to replace, and press the **ENT** key.

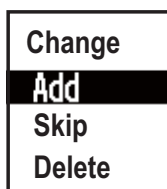

7. Select [Change], and press the **ENT** key.
8. Select [Alpha] or [Local], and press the **ENT** key to show the waypoint list.
9. Select the new waypoint, and press the **ENT** key.
10. Press the **MENU/ZOOM** key several times to close the menu.

4.2.2 How to delete a waypoint from a route

1. Press the **MENU/ZOOM** key twice to show the main menu.
2. Select [Routes], and press the **ENT** key.
3. Select [Alpha] or [Local], and press the **ENT** key to show the route list.
4. Select the route to edit, and press the **ENT** key.
5. Select [Edit], and press the **ENT** key to show the route information.
6. Select the waypoint to delete from the route, and press the **ENT** key.
7. Select [Delete], and press the **ENT** key.
8. Press the **MENU/ZOOM** key several times to close the menu.

4.2.3 How to insert a waypoint in a route

To insert a waypoint in a route, do the following:

1. Press the **MENU/ZOOM** key twice to show the main menu.
2. Select [Routes], and press the **ENT** key.
3. Select [Alpha] or [Local], and press the **ENT** key to show the route list.
4. Select the route to edit, and press the **ENT** key.
5. Select [Edit], and press the **ENT** key to show the route list.
6. Select the waypoint which will come after the waypoint to be inserted, and press the **ENT** key.
7. Select [Add], and press the **ENT** key.
8. Select [Alpha] or [Local], and press the **ENT** key to show the waypoint list.
9. Select the waypoint, and press the **ENT** key.
10. Press the **MENU/ZOOM** key several times to close the menu.

4.2.4 How to temporarily deselect a waypoint in a route

You can temporarily deselect an unnecessary waypoint from a route. Using the route created in the illustration shown below as an example, deselect the second intermediate waypoint.

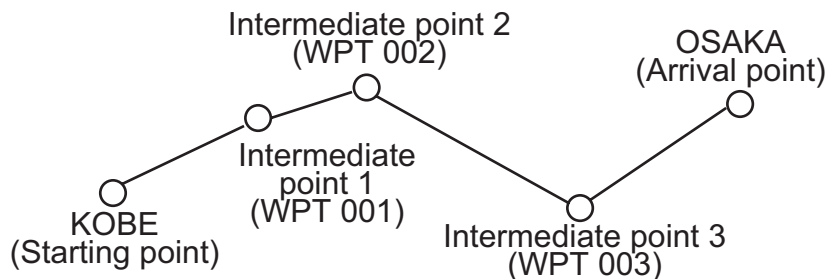

If you reconstruct the route without the second intermediate point it would look like the illustration below.

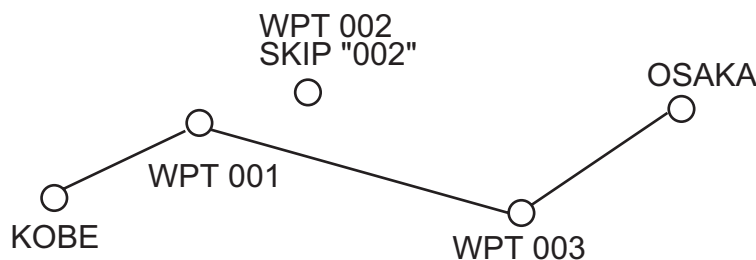

1. Press the **MENU/ZOOM** key twice to show the main menu.
2. Select [Routes], and press the **ENT** key.
3. Select [Alpha] or [Local], and press the **ENT** key to select the route list.
4. Select the route to edit, and press the **ENT** key.
5. Select [Edit], and press the **ENT** key to show the route information.
6. Select the waypoint to skip, and press the **ENT** key.
7. Select [Skip], and press the **ENT** key to show "X" next to the waypoint chosen at step 6.

- Press the **MENU/ZOOM** key several times to close the menu.

Note: To restore waypoint to a route, select [Skip Off] at step 7, and press the **ENT** key.

4.3 How to Erase a Route

You can erase routes individually or collectively.

4.3.1 How to erase a route through the route list

Note: The route used as route navigation can not be erased.

- Press the **MENU/ZOOM** key twice to show the main menu.
- Select [Routes], and press the **ENT** key.
- Select [Alpha] or [Local], and press the **ENT** key to show the route list.
- Select the route to erase, and press the **ENT** key.
- Select [Delete], and press the **ENT** key to erase the route chosen at step 4.
- Press the **MENU/ZOOM** key several times to close the menu.

4.3.2 How to erase all routes

- Press the **MENU/ZOOM** key twice to show the main menu.
- Select [Delete], and press the **ENT** key.
- Select [All Routes], and press the **ENT** key.
- Select [Delete], and press the **ENT** key to show the following message.

Delete all routes.
Are you sure?
Yes **No**

When no route is set as destination

Route is set as destination.
Are you sure to delete all routes?
Yes **No**

When a route is set as destination

- Select [Yes], and press the **ENT** key to erase all routes.
Note: To cancel, select [No].
- Press the **MENU/ZOOM** key twice to close the menu.

4. ROUTES

This page is intentionally left blank.

5. DESTINATION

Destination can be set four ways: by cursor, by waypoint, by route and by MOB position. Previous destination is cancelled whenever a new destination is set. The setting by MOB position is described in chapter 1. When setting a destination, a blue line is shown between own boat and the destination selected. Also, the range and bearing from own boat to the destination are shown at the left-hand side of the screen.

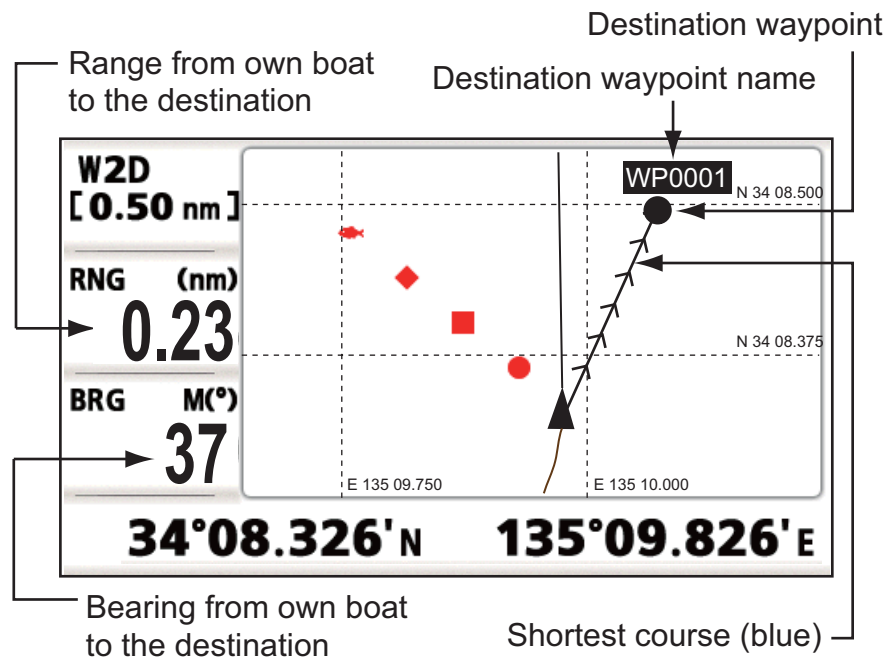

5.1 How to Set Destination by Cursor Position

You can set a destination at the position with no waypoint. This destination is called "Quick Point".

1. On the plotter display, operate the cursorpad to place the cursor on the location desired for destination.
2. Press the **GO TO** key to enter the waypoint as the quick point. The quick waypoint is shown with a green solid circle, and named as "QP". This point is saved in the waypoint list automatically.
3. Cancel the destination, referring to section 5.4, when arriving at the waypoint.

Note: The quick point set is erased when a new one is entered.

5.2 How to Set Destination by Waypoint

You can set a waypoint as destination by using the cursor or the waypoints list.

5.2.1 How to set a destination waypoint with the cursor

1. On the plotter display, operate the cursorpad to place the cursor on the waypoint which you want to set as the destination.
2. Press the **ENT** key.

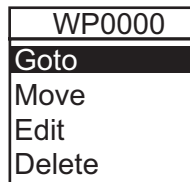

3. Select [Goto], and press the **ENT** key.
4. Cancel the destination referring to section 5.4 when arriving at the waypoint.

5.2.2 How to set a destination waypoint through the list

1. Press the **MENU/ZOOM** key twice to show the main menu.
2. Select [Waypoints], and press the **ENT** key.
3. Select [Alpha] or [Local], and press the **ENT** key to show the waypoint list.

Menu >Waypoints >Waypoint List					
Name	Symbol	Color	RNG (nm)	BRG (°)	
[New]					
G WP0001	●	Red	115	115	
WP0002	■	Red	116	116	
WP0003	◆	Red	117	117	
WP0004	⦿	Red	118	118	
WP0005	⦿	Red	119	119	

[MENU/ZOOM] :Cancel/Back [ENT] :Enter ▲/▼:Select

4. Select the waypoint to set as a destination, and press the **ENT** key.



5. Select [Goto], and press the **ENT** key to show the plotter display.
6. Cancel the destination referring to section 5.4 when arriving at the waypoint.

5.3 How to Set Route as Destination

You can set a route as destination through the list.

1. Press the **MENU/ZOOM** key twice to show the main menu.
2. Select [Route], and press the **ENT** key.

3. Select [Alpha] or [Local], and press the **ENT** key.

Menu >Routes >Route List				
Name		TLEG (nm)	Number	
(New)				
RT000	: WP000 ->WP0001	0.85	2	
RT001	: WP003 ->WP0001	0.06	2	
RT002	: WP001 ->WP0005	1.83	3	
RT003	: WP001 ->WP0004	3.54	4	

[MENU/ZOOM] :Cancel /Back [ENT] :Enter ▲/▼ :Select

4. Select the route to set as a destination, and press the **ENT** key.

Goto
Edit
Delete

5. Select [Goto], and press the **ENT** key.
6. Select [Forward] or [Reverse].
Forward: Follows waypoints in order registered (1→2→3...)
Reverse: Follows waypoints in reverse order registered (30 (when maximum entered) →29→28...→1)
7. Press the **ENT** key to show the plotter display. The destination route is shown with waypoints connected with legs.
8. Cancel the destination referring to section 5.4 when arriving at the waypoint.

How to change the following direction after you set a route as destination

After you start doing the route destination, you can change the following direction, [Forward]→[Reverse] or vice versa. Place the cursor on a leg of the route, and press the **ENT** key to show the following pop-up window. Select [Reverse] (or [Forward]). Then, select [Yes] and press the **ENT** key.

RT0000
Cancel Route
Reverse
Route Info.

Note: If your boat has not yet arrived at the first waypoint in the route, the current route destination is cancelled if you select [Reverse] (or [Forward]). Set the route destination again.

5.4 How to Cancel Destination

You can cancel destination by using the cursor, or through the list.

5.4.1 How to cancel destination with the cursor

1. On the plotter display, operate the cursorpad to place the cursor on the waypoint (route) set as the current destination.

5. DESTINATION

- Press the **ENT** key.

WP0001
Move
Cancel Goto
Edit
Delete

QP0001
Move
Cancel Goto
Edit
Delete

WP0001
Move
Skip
Cancel Route
Edit

RT0000
Cancel Route
Reverse
Route Info.

(for waypoint destination) (for QP destination) (for route navigation) (for route leg)

- Select [Cancel Goto (Route)], and press the **ENT** key.

Cancel Goto. Are you sure?
Yes No

Cancel Route Navigation. Are you sure?
Yes No

(for waypoint destination) (for route navigation)

- Chose [Yes], and press the **ENT** key.
To cancel, select [No].

5.4.2 How to cancel destination through the list

- Press the **MENU/ZOOM** key twice to show the main menu.
- Select [Waypoints] (or [Routes]), and press the **ENT** key twice.
- Select the waypoint (route) set as the current destination.

Menu >Waypoints >Waypoint List					
Name	Symbol	Color	RNG (nm)	BRG (°)	
(New)					
G WP0001	●	Red	115	115	
WP0002	■	Red	116	116	
WP0003	◆	Red	117	117	
R WP0004	✈	Red	118	118	
WP0005	✈	Red	119	119	

Destination mark →

Waypoint used for destination route →

[MENU/ZOOM] :Cancel/Back [ENT] :Enter ▲/▼ :Select

- Press the **ENT** key.

Cancel Goto
Edit
Delete

Cancel Route
Edit
Delete

(for waypoint destination) (for route navigation)

- Select [Cancel Goto (Route)], and press the **ENT** key.

Cancel Goto. Are you sure?
Yes No

Cancel Route Navigation. Are you sure?
Yes No

(for waypoint destination) (for route navigation)

- Select [Yes], and press the **ENT** key.
To cancel, select [No].
- Press the **MENU/ZOOM** key several times to close the menu.

6. ALARMS

6.1 Overview

There are nine alarm conditions which generate both audio and visual alarms: Arrival alarm, Anchor watch alarm, XTE (Cross-Track Error) alarm, Speed alarm, Speed Based Output alarm, WAAS/DGPS alarm, Time alarm, Trip alarm and Odometer alarm.

When an alarm setting is violated, the buzzer sounds and the name of the offending alarm and the alarm icon appear on the display (alarms other than Speed Based Output).

You can silence the buzzer and remove the alarm name indication by pressing any key. The alarm icon remains on the screen until the reason for the alarm is cleared.

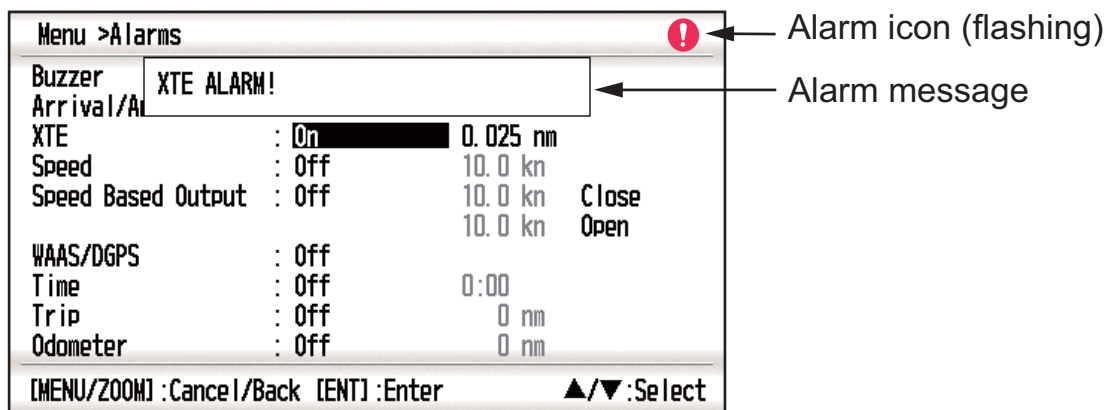

To know which alarm has been violated, do the following procedure.

1. Press the **MENU/ZOOM** key twice to show the main menu.
2. Select [Messages], and press the **ENT** key.

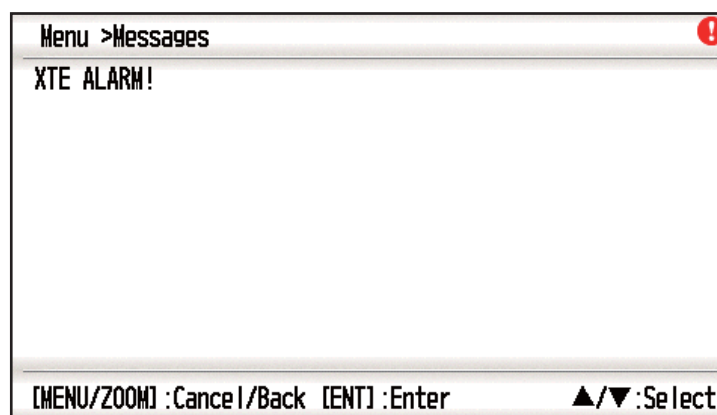

Example alarm message

The display shows the names of offending alarms. When there are no alarms, the message "No Message!" appears.

Message and meanings

Message	Meaning
XTE ALARM!	The boat is off its intended course by the range set.
TIME ALARM!	The time set has come.
SPEED ALARM!	The boat's speed is higher than the range set.
ARRIVAL ALARM!	The boat is approaching the arrival area.
TRIP ALARM!	The boat has traveled further than the preset trip distance.
ODOMETER ALARM!	The boat has traveled the total distance set.
ANCHOR WATCH!	The boat has moved a certain distance (when it should be at rest).
NO WAAS SIGNAL!	WAAS signal cannot be found.
NO DGPS SIGNAL!	DGPS signal cannot be found.
NO WAAS/DGPS SIGNAL!	WAAS and DGPS signal cannot be found.

Note: The message screen also shows equipment trouble. See section 8.3.

6.2 Buzzer Type Selection

The buzzer sounds whenever an alarm setting is violated. You can select the type of buzzer as follows:

1. Press the **MENU/ZOOM** key twice to show the main menu.
2. Select [Alarms], and press the **ENT** key.
3. Select [Buzzer], and press the **ENT** key.



4. Select buzzer type, and press the **ENT** key.
 Short: A short beep sounds.
 Long: Three long beeps sound.
 Continuous: Continuous long beeps sound until a key is pressed.
5. Press the **MENU/ZOOM** key twice to close the menu.

6.3 How to Set an Alarm

Set alarms as below:

Note: For the Anchor alarm, press the **WPT/MOB** key to enter the waypoint at own boat's position, and set it as destination referring to paragraph 5.2.1.

1. Press the **MENU/ZOOM** key twice to show the main menu.

2. Select [Alarms], and press the **ENT** key.

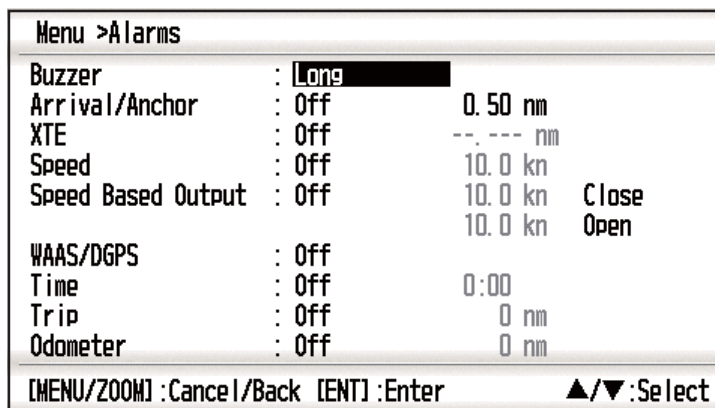

3. Select an alarm item, and press the **ENT** key.
4. Do one of the following:
 - (Arrival/Anchor)
 - 1) Select [Arrival] or [Anchor], and press the **ENT** key.
 - 2) Press ► and **ENT** key.
 - 3) Enter the alarm area, and press the **ENT** key.
 - (XTE, Speed, Trip and Odometer)
 - 1) Select [On], and press the **ENT** key.
 - 2) Press ► and **ENT** key.
 - 3) Enter the value, and press the **ENT** key.
 - (WAAS/DGPS)

Select [On], and press the **ENT** key.
 - (Time)
 - 1) Select [On], and press the **ENT** key.
 - 2) Press ► and **ENT** key in order.
 - 3) Enter the time, and press the **ENT** key.
 - 4) For 12-hour clock, press ► and **ENT** key.
 - 5) Select [AM] or [PM], and press the **ENT** key.
 - (Speed Based Output)
 - 1) Select [On], and press the **ENT** key.
 - 2) Press ► and **ENT** key.
 - 3) Enter the speed at which to close the contact signal, and press the **ENT** key.
 - 4) Press ▼ and **ENT** key.
 - 5) Enter the speed to open the contact signal, and press the **ENT** key.
5. Press the **MENU/ZOOM** key twice to close the menu.

Note 1: To cancel an alarm, select [Off] at 1) on step 4.

Note 2: You can activate the arrival alarm or the anchor watch alarm; they cannot be activated together.

6.4 Alarm Descriptions

Arrival alarm

The arrival alarm informs you that own boat is approaching a destination waypoint. The area that defines an arrival zone is that of a circle which you approach from the outside of the circle. The alarm will activate if your boat enters the circle.

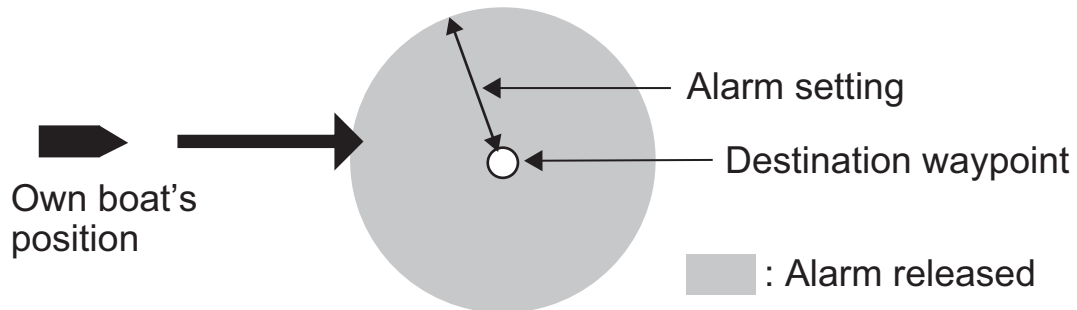

How the arrival alarm works

Anchor watch alarm

The anchor watch alarm sounds to warn you that your boat is moving when it should be at rest. Before setting the anchor watch alarm, set current position as destination waypoint.

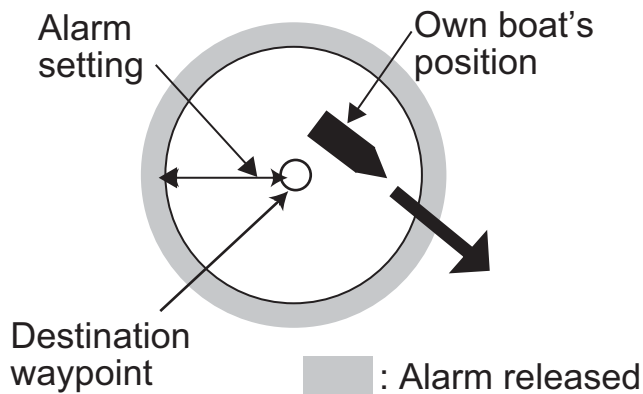

How the anchor watch alarm works

XTE (Cross-Track Error) alarm

The XTE alarm warns you when own boat is off its intended course.

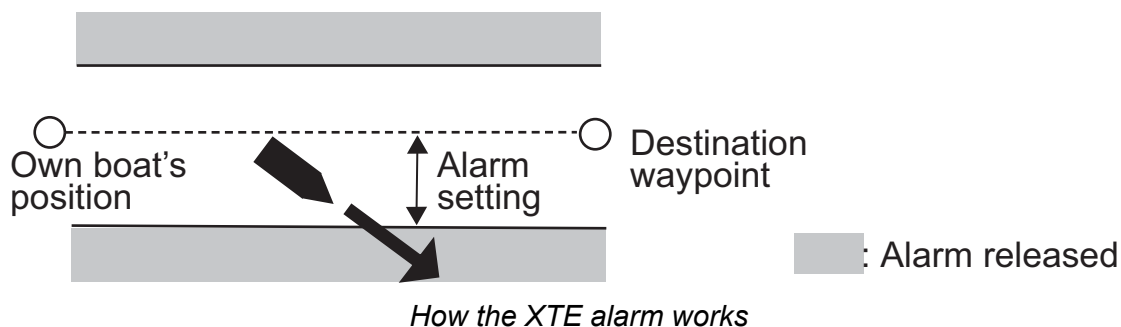
**Speed alarm**

The speed alarm alerts you when the boat's speed is higher than the alarm range set.

WAAS/DGPS alarm

This alarm alerts you when the WAAS or DGPS signal is lost (status indication except W2D/W3D/D2D/D3D). Note that On cannot be chosen if [Mode] in Menu>WAAS/DGPS is set to GPS.

Time alarm

The time alarm works like an alarm clock, releasing audio and visual alarms when the time entered has come.

Trip alarm

The trip alarm tells you when your boat has traveled further than the preset trip distance.

Odometer alarm

This alarm alerts you when your boat has traveled the total distance you set.

Speed Based Output

This alarm is for a boat that has a control system that applies the boat's speed. The contact signal is normal open. When your boat's speed is faster than the [Close] setting, the contact signal is closed. When your boat's speed is less than the [Open] setting, the contact signal is opened.

6. ALARMS

This page is intentionally left blank.

7. OTHER FUNCTIONS

This chapter describes menu items not carried in other chapters.

7.1 Plotter Setup Menu

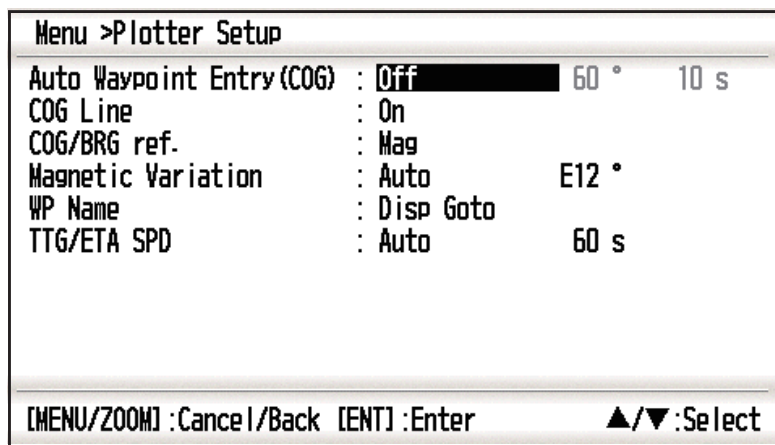

COG Line

You can show or hide the COG line on the plotter display.

COG/BRG ref.

Boat's course and bearing to a waypoint are displayed in true or magnetic bearing. Magnetic bearing is true bearing plus (or minus) earth's magnetic variation. Select the bearing reference in according to the compass installed: magnetic for magnetic compass, true for gyrocompass or satellite compass using true bearing.

Magnetic Variation

The location of the magnetic north pole is different from the geographical north pole. This causes a difference between the true and magnetic north direction. The difference is called magnetic variation, and varies with respect to the observation point on earth. Your unit is pre-programmed with all the earth's magnetic variation. However, you may wish to enter variation manually to refine accuracy using the latest chart. Set [COG/BRG ref.] on the Plotter Setup menu to [Mag] to use magnetic variation.

To enter magnetic variation manually, do the following:

- 1) If necessary, change coordinate from east to west or vice versa.
- 2) Enter the value referring to a recent nautical chart.
- 3) Press the **ENT** key.

TTG/ETA SPD

To calculate time to go and estimated time of arrival, enter your speed as below.

-Auto (GPS calculated speed)

1. Press ► and **ENT** in order.
2. Enter the speed average (1 to 999 sec.) to use, and press the **ENT** key.

-Manual (Speed calculated manually)

1. Press ► and **ENT** in order.
2. Enter speed (1 to 999 knot), and press the **ENT** key.

7.2 GPS Setup Menu

The GPS Setup menu smooths position and course, averages speed, applies position offset, and deactivates unhealthy satellites.

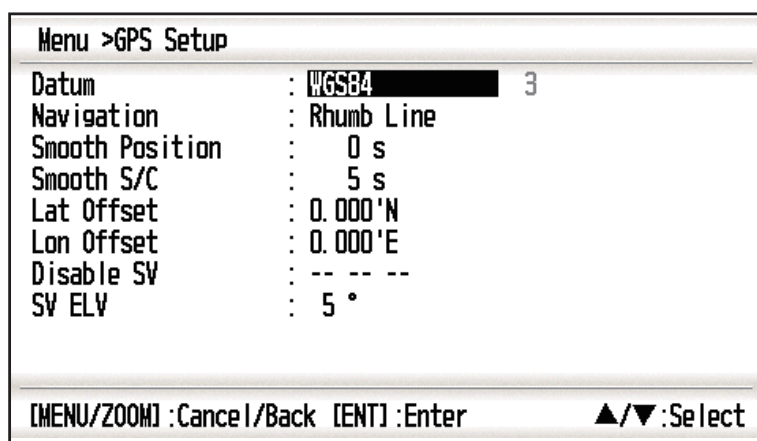
**Datum**

Your unit is programmed to recognize most of the major chart systems of the world. Although the WGS-84 system, the GPS standard, is now widely used other categories of charts still exist. Select the same datum which is used in your nautical charts. Select WGS84 (default setting), WGS72 or Other (required the datum number entering).

Navigation

When you set a destination, the equipment displays the range, bearing and course to that destination. Range and bearing are calculated by the Great Circle or Rhumb Line method. Route total distance is also calculated. Cross-track error is only calculated in the Rhumb Line method.

Rhumb line: This method calculates the range and bearing between two points drawn on a nautical chart. Since the bearing is kept constant it is ideal for short-range navigation.

Great circle: This course line is the shortest course between two points on the surface of the earth, like stretching a piece of string between two points on earth. Frequent bearing changes are required to navigate by this method. For long-range navigation, divide the Great Circle route into several routes, and navigate each route by Rhumb Line.

Smooth Position

When the receiving condition is unfavorable, the GPS fix may change randomly, even if the boat is dead in water. This change can be reduced by smoothing the raw GPS fixes. The setting range is from 0 (no smoothing) to 999 seconds. The higher the setting the more smoothed the raw data, however too high a setting slows response time to change in latitude and longitude. This is especially noticeable at high boat speeds. "0" is the normal setting; increase the setting if the GPS fix changes randomly.

Smooth S/C (speed/course)

During position fixing, your boat's velocity (speed and course) is directly measured by receiving GPS satellite signals. The raw velocity data may change randomly depending on receiving conditions and other factors. You can reduce this random variation by increasing the smoothing. Like with latitude and longitude smoothing, the higher the speed and course smoothing the more smoothed the raw data. If the setting is too high, however, the response to speed and course change slows. The setting range is from 0 (no smoothing) to 9999 seconds.

Lat Offset. Lon Offset

If there is the error between the positions shown on your equipment and chart when docking at a pier, you may apply an offset to latitude and longitude position. Mark own boat's position on the chart to calculate the error with latitude and longitude, and enter the values.

Disable SV (satellite)

Every GPS satellite is broadcasting abnormal satellite number(s) in its Almanac, which contains general orbital data about all GPS satellites. Using this information, the GPS receiver automatically eliminates any malfunctioning satellite from the GPS satellite schedule. However, the Almanac sometimes may not contain this information. You can disable an inoperative satellite manually. Enter satellite numbers (max. three satellites) in two digits.

SV ELV (satellite elevation)

Set the minimum elevation of satellites to use to fix position.

7.3 WAAS/DGPS Menu

Menu >WAAS/DGPS	
Mode	: WAAS
WAAS Search	: Auto 134
Corrections Data Set:	0*
DGPS Station	: Auto
RATE	: 200BPS
FREQ	: 310.0 kHz
Data	: ---
SIG. S	: 00.0dB SNR : 00.0dB
[MENU/ZOOM] :Cancel/Back [ENT] :Enter ▲/▼:Select	

*Use "0" (as default setting).

Mode

You can select [WAAS], [GPS] or [DGPS] for the position fixing mode. When selecting [Auto], the mode automatically switches to WAAS with no DGPS signal. When selecting [WAAS], [DGPS] or [Auto], the mode automatically switches to GPS with no WAAS or DGPS signal.

Note: A DGPS beacon receiver required to add DGPS capability.

WAAS Search

For WAAS setting, the GEO satellite is searched automatically or manually. For GEO satellite number, see page AP-3.

Auto: The system automatically searches for the optimum GEO satellite from your current position. (All satellites are searched.)

Manual: Enter a GEO satellite number manually.

Correction Data Set

Use [0] as default setting.

DGPS Station

The DGPS station is searched automatically or manually.

Auto: The system automatically searches for the DGPS station.

Manual: Set the rate and frequency for the DGPS station manually.

RATE

When selecting [Manual] in the [DGPS Station] menu, select the bit rate for the DGPS station from [50BPS], [100BPS] or [200BPS].

FREQ

When selecting [Manual] in the [DGPS Station] menu, set the frequency for the DGPS station (setting range: 283.5 to 325.0 kHz; 0.5 kHz step).

Data

The current communication status for the beacon receiver is displayed.

- When [Mode] is set to [DGPS] or [Auto]:
 - [OK] is displayed if the data can be received from the beacon receiver.
 - [NG] is displayed if the data can not be received from the beacon receiver for 60 seconds or above.
- When [Mode] is set to [GPS] or [WAAS], "-- --" is displayed.

SIG.S

The signal intensity from the DGPS station is displayed. "00.0dB" is displayed except [Mode] is set to [DGPS] or [Auto].

SNR

The signal-to-noise ratio from the DGPS station is displayed. "00.0dB" is displayed except [Mode] is set to [DGPS] or [Auto].

7.4 Position Display Format

Position can be shown in latitude and longitude or TDs (Loran C). Loran C chain data is programmed into the equipment.

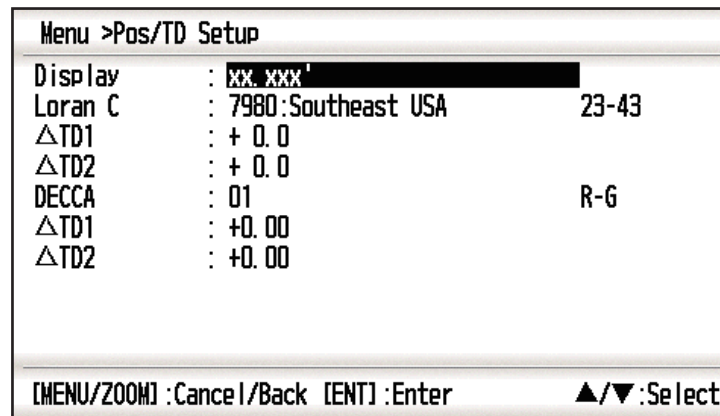
**Display**

Select the position format.

- xx.xxx': Shows L/L position with no seconds.
- xx'xx.x": Displays L/L position with seconds.
- LC TD: Loran C TDs
- DE TD: DECCA TDs

Loran C

When choosing LC TD at Display, do the following:

- 1) Press the **ENT** key.
- 2) Select the GRI code, and press the **ENT** key.
- 3) Press ► and **ENT** key.

7. OTHER FUNCTIONS

4) Select the pair of slave station, and press the **ENT** key.

△TD1, △TD2

Enter TD offsets to refine Loran C position accuracy.

DECCA

When choosing DE TD at Display, do the following:

- 1) Press the **ENT** key.
- 2) Select the decca chain no., and press the **ENT** key.
- 3) Press **▶** and **ENT** key.
- 4) Select the pair of slave station, and press the **ENT** key.

△TD1, △TD2

Enter TD offsets to refine Decca position accuracy.

7.5 System Menu

In the System menu, you can customize various display settings, for example, time and date formats, etc.

Menu >System	
Key Beep	: Off
Language	: English
Units	: nm, kn
Time Offset	: - 8:00
Daylight Saving Time	: Off
Time Display	: 24Hour
Date Display	: DD/MM/YY
Demo	
Self Test	
Reset	

[MENU/ZOOM] :Cancel/Back [ENT] :Enter ▲/▼:Select

Key Beep

This item turns the key beep on or off.

Units

The Units item lets you select the unit of measurement for range, speed and distance, from the units shown below.

nm, kn
km, km/h
sm, mph

Time Offset

GPS uses UTC time. If you would rather use local time, enter the time difference (range: -14:00 to +14:00, 15 minutes step) between it and UTC time.

Daylight Saving Time

For countries that use daylight savings time, select On to enable daylight savings time.

Time Display

You can display the time in 12 or 24 hour format.

Date Display

Select the date display, DD/MMM/YY or MM/DD/YY.

Demo

The demonstration display provides simulated operation of this unit. You may set the speed manually and course manually or automatically. All controls are operative - you may enter marks, set destination, etc.

- **Mode:** Select [On]. The indication SIM appears at the top left-hand side to inform you that the simulation mode is in use. To cancel, select [Off].
- **Speed:** Enter the speed (two digits) to use for the demonstration mode.
- **Course:** Select Auto or Manual. For manual entry of course, enter course in three digits. The Auto course tracks a circular course.
- **Lat, Lon:** Enter latitude and longitude of the position to start the demonstration.

Reset (Trip)

You can reset the trip meter to zero. Select [On] at [Trip] on System>Reset menu.

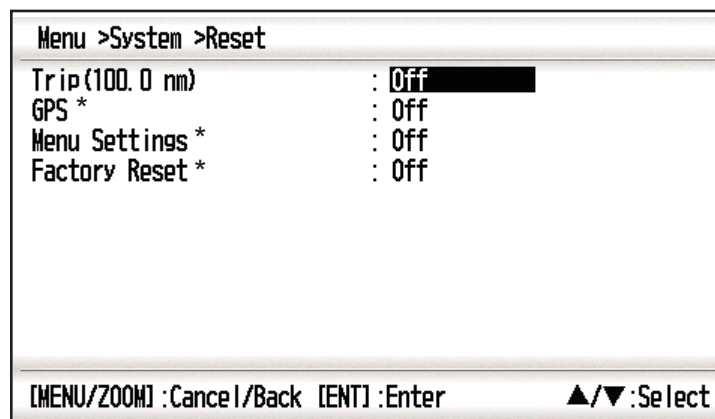

*: Items to be cleared (See section 8.5.)

7.6 User Display Menu

To customize user displays, which are [6] and [7] appeared when the **DISP** key is pressed (see section 1.4), use the User Display menu.

	DISP key is pressed	Item name on User Display menu
User display 1	Display [6]	Display 1
User display 2	Display [7]	Display 2

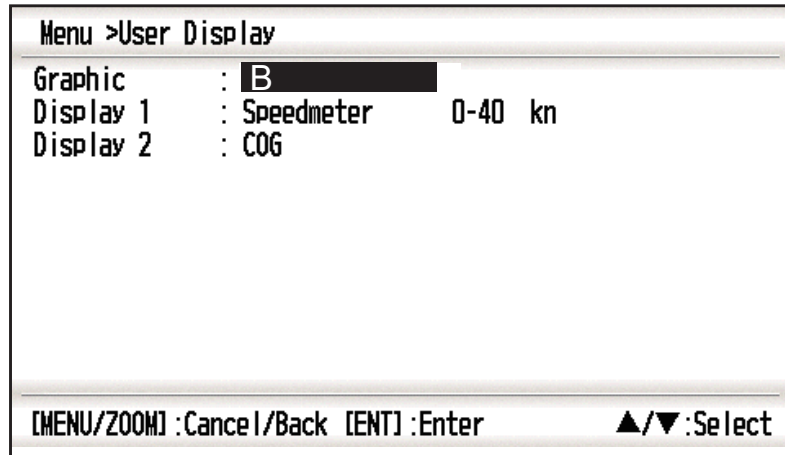

Note: You can show the User Display menu by pressing the **ENT** key more than three seconds at the User display 1 (display [6]) and 2 ([7]).

Graphic

You can select the graphic type for the analog COG and speedometer displays from two patterns (A and B) which have different character font and scale steps. Note that the graphic selected here can affect minor changes to other displays.

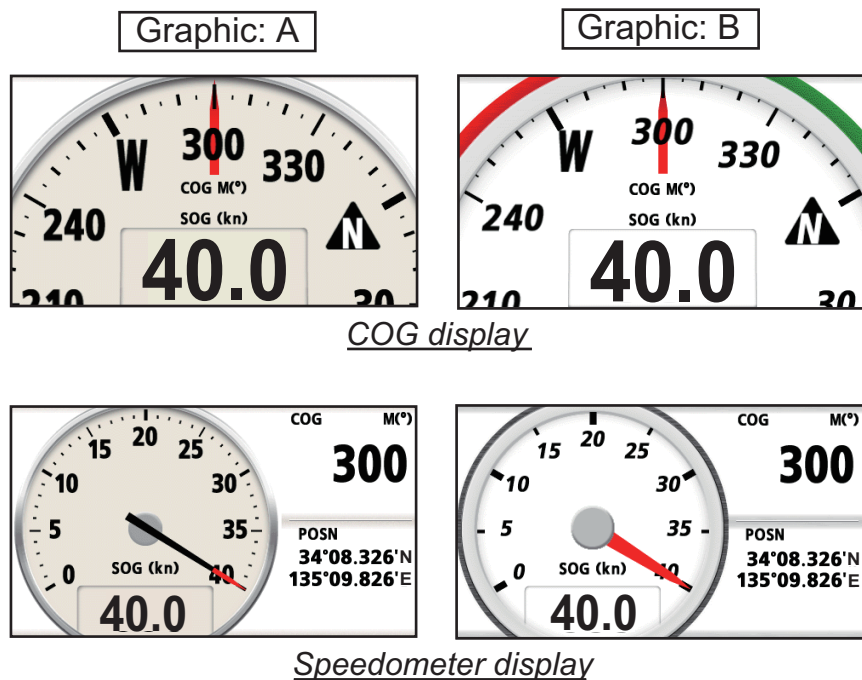

Display 1, Display 2

You can select items to show on the User display 1 (display [6]) and 2 ([7]), from among digital data, speedometer and COG (see page 1-7). When choosing [Off] for Display 2, for example, the display [7] is not shown.

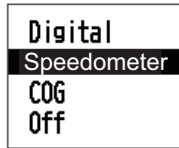

For [Digital], you can display one to four items of digital navigation data on the user display.

1. Press **▶** and **ENT** key in order to show the following window.



2. Select the screen division, which is the number of data to display, and press the **ENT** key.
The display now looks something like the one shown below, showing data choices and screen division selected.

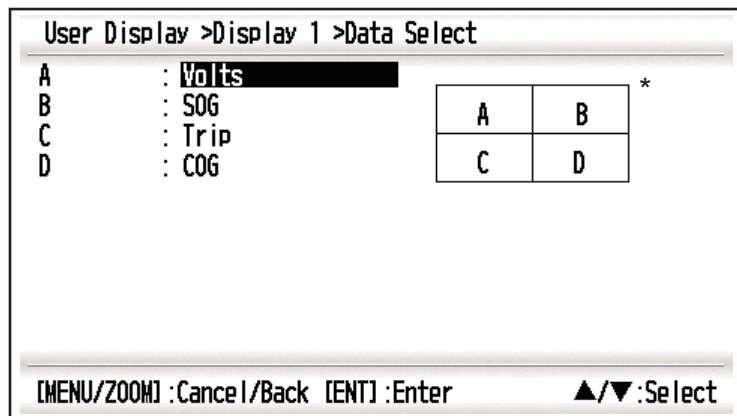

*: Depending on the selection at step 2.

A
A
B

A	B
C	D

3. Select [A], [B], [C] or [D], and press the **ENT** key.



Page 1

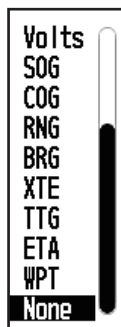

Page 2

ODO: Odometer distance	XTE: Cross-track error
Trip: Trip distance	TTG: Time to go (to destination)
Time: Time	ETA: Estimated time to arrival (to destination)
Date: Date	WPT: Range and bearing to waypoint
POSN: Position	None: No display
Volts: Power voltage	
SOG: Speed over ground	
COG: Course over ground	
RNG: Range	
BRG: Bearing	

7. OTHER FUNCTIONS

4. Select data desired, and press the **ENT** key.
5. Repeat steps 3 and 4 to set other data.

You can select digital data also from the User display 1 (display [6]) and 2 ([7]) directly.

1. Press the **DISP** key several times to show User display 1 or 2 desired, and press the **ENT** key to show the cursor.

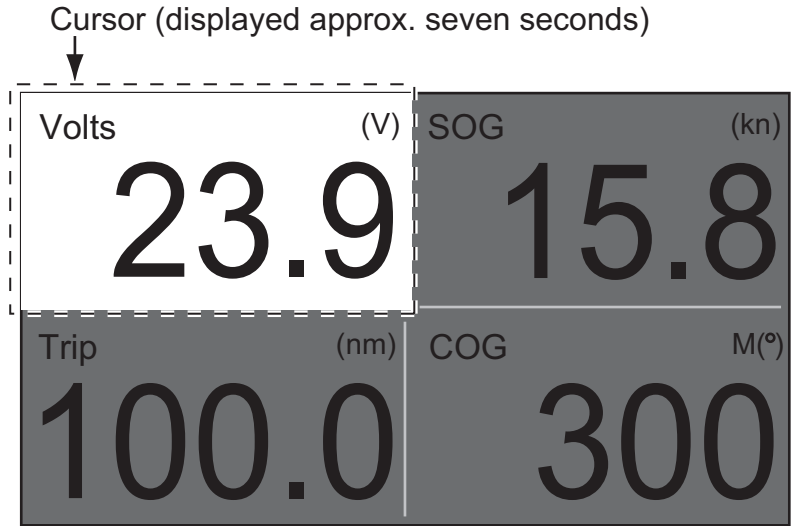

2. Operate the cursorpad to select the column to select data, and press the **ENT** key.

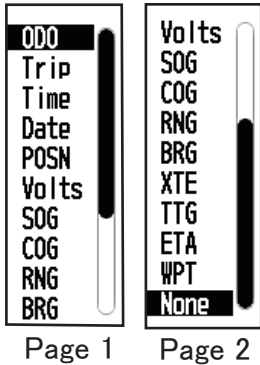

- ODO: Odometer distance
- Trip: Trip distance
- Time: Time
- Date: Date
- POSN: Position
- Volts: Power voltage
- SOG: Speed over ground
- COG: Course over ground
- RNG: Range
- BRG: Bearing
- XTE: Cross-track error
- TTG: Time to go (to destination)
- ETA: Estimated time to arrival (to destination)
- WPT: Range and bearing to waypoint
- None: No display

3. Select the item to show, and press the **ENT** key.
4. Repeat steps 2 and 3 for other displays if necessary.

Speedometer

When choosing [speedometer], you can select the range for the speedometer to show on the User display 1 or 2.

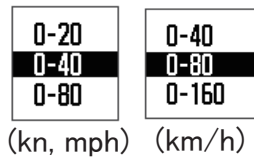

7.7 I/O Setup Menu

Waypoint and route data can be uploaded from your unit to a PC, or downloaded from a PC to your unit.

There are two kinds of data for route data: route data and route comment data.

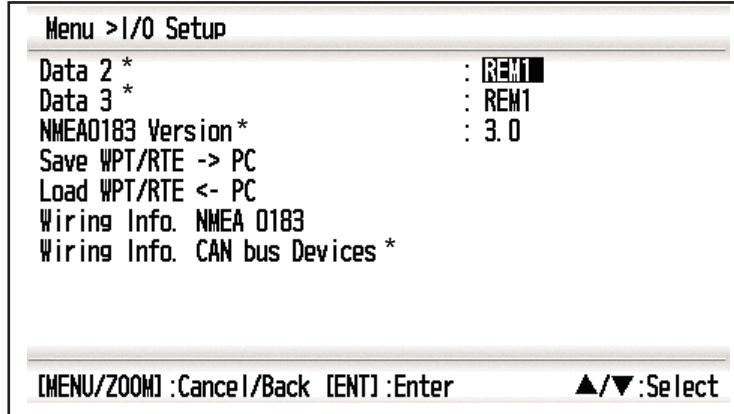

*: See chapter 9.

Note: No position fix is available during uploading or downloading.

Setting for communication software on PC

Baud Rate	<ul style="list-style-type: none"> Navigation data output: 4800 bps Waypoint/route information upload/download: 38400 bps
Character Length	8 bit
Parity	None
Stop Bit	1 bit
Flow Control	XON/OFF

7. OTHER FUNCTIONS

Waypoint data format

\$PFEC,	GPwpl,	<u>llll.ll</u> ,	<u>a</u> ,	<u>yyyyy.yy</u> ,	<u>a</u> ,	<u>c--c</u> ,	<u>c</u> ,	<u>c--c</u> ,	<u>a</u> ,	<u>hhmmss</u> ,	<u>xx</u> ,	<u>xx</u> ,	<u>xxxx</u>	<CR><LF>
		1	2	3	4	5	6	7	8	9	10	11	12	

- 1: Waypoint latitude
- 2: N/S
- 3: Waypoint longitude
- 4: E/W
- 5: Waypoint name (1 to 8 characters)
- 6: Waypoint color
(NULL/0: black, 1: red, 2: yellow, 3: green, 4: brown, 5: purple, 6: blue)
- 7: Waypoint mark and waypoint comment ("@_ (see below.)" + 0 to 13 characters)
 - Following characters can be used for comments:
_ABCDEFGHIJKLMNPOQRSTUVWXYZ0123456789&()+-/?> (space)
 - Following marks are waypoint marks:
●: @q, ■: @r, ◆: @s, 🐟: @t, ☘: @u,
☘: @v, 🌊: @w, ⚓: @x, ☠: @y, 🚩: @z
- 8: Flag marking waypoint (A: displayed, V: Not displayed)
- 9: UTC (Always NULL)
- 10: Day (Always NULL)
- 11: Month (Always NULL)
- 12: Year (Always NULL)

Route data format

\$GPRTE,	<u>x.x</u> ,	<u>x.x</u> ,	<u>a</u> ,	<u>c--c</u> ,	<u>c--c</u> ,	...	<u>c--c</u>	<CR><LF>
	1	2	3	4	5		12	

- 1: Number of sentences required for one complete route data (1 to 6) See note.
- 2: Number of sentences currently used (1 to 6)
- 3: Message mode (Always set to "C".)
- 4: Route No. (1 to 100)
- 5 to 12: Waypoint name (1 to 8 characters, length of each waypoint name is fixed to 7 byte)
 - 1st byte: "-" (hyphen)= skip ON, " " (space)= skip OFF
 - After 2nd byte: Waypoint name (1 to 8 characters)

Note: A route can contain max.30 waypoints and GPRTE sentence for one route data may exceed 80 byte limitation. In this case, route data is divided into several GPRTE sentences (max. 4 sentences). This value shows the number of sentences route data has been divided.

Route comment data format

<pre>\$PFEC, GPrtc, <u>x</u>, <u>c--c</u>, <u>c--c</u> <CR><LF> 1 2 3</pre>

- 1: Route No. (1 to 100)
- 2: Route comment (Max. 18 characters, variable length)
- 3: Route name (Max. 6 characters, variable length)

End of sentence

<pre>\$PFEC, GPxfr, CTL, E <CR><LF></pre>

7.7.1 Uploading data to a PC

1. Connect a PC to your GP-33, referring to the interconnection diagram at the back of this manual.
2. Press the **MENU/ZOOM** key twice to show the main menu.
3. Select [I/O Setup], and press the **ENT** key.
4. Select [Save WPT/RTE -> PC], and press the **ENT** key.

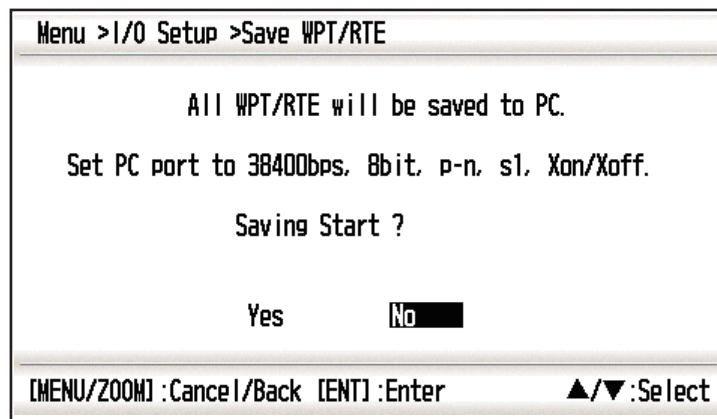

5. Press **◀** to select [Yes], and press the **ENT** key to start the uploading.
6. When the completion message appears, press any key to finish.

7.7.2 Downloading data from PC

Note that all waypoint and route data stored in the GP-33 will be deleted when data is downloaded from PC.

1. Connect a PC to your GP-33, referring to the interconnection diagram at the back of this manual.
2. Press the **MENU/ZOOM** key twice to show the main menu.
3. Select [I/O Setup], and press the **ENT** key.

7. OTHER FUNCTIONS

4. Select [Load WPT/RTE <- PC], and press the **ENT** key.

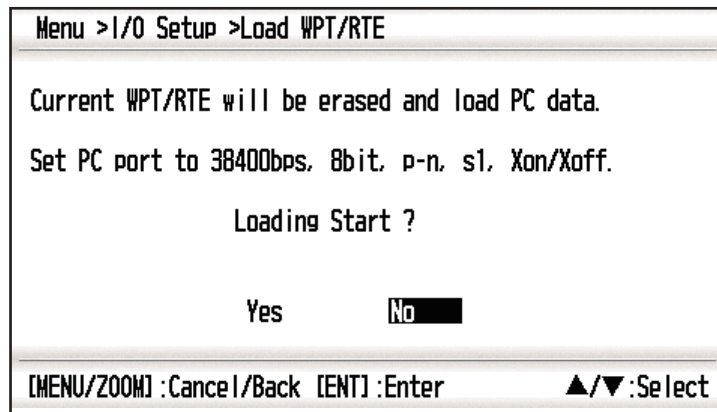

5. Press ◀ to select [Yes], and press the **ENT** key to start the downloading.
6. After the completion message appears, press any key to finish.

8. MAINTENANCE, TROUBLE-SHOOTING

NOTICE

Do not apply paint, anti-corrosive sealant or contact spray to plastic parts or equipment coating.

Those items contain products that can damage plastic parts and equipment coating.

8.1 Maintenance

Regular maintenance is important to maintain performance. Check the following points to help maintain performance.

- Check that connectors on the rear panel are firmly tightened and free of rust.
- Check that the ground system is free of rust and the ground wire is tightly fastened.
- Check that battery terminals are clean and free of rust.
- Dust or dirt may be removed from the cabinet with soft cloth. Water-diluted mild detergent may be used if desired. DO NOT use chemical cleaners to clean the display unit; they may remove paint and markings.
- Wipe the LCD carefully to prevent scratching, using tissue paper and an LCD cleaner. To remove dirt or salt deposits, use an LCD cleaner, wiping slowly with tissue paper so as to dissolve the dirt or salt. Change paper frequently so the salt or dirt will not scratch the LCD. Do not use solvents such as thinner, acetone or benzene for cleaning. Also, do not use degreaser or antifog solution, as they can strip the coating from the LCD.

Life of LCD

The life of the LCD is approximately 50,000 hours. The actual number of hours depends on ambient temperature and humidity. When the brilliance cannot be raised sufficiently, ask your dealer about replacement.

8.2 Troubleshooting

This section provides simple troubleshooting procedures which the user can follow to restore normal operation. If you cannot restore normal operation, do not attempt to check inside the unit. Any trouble should be referred to a qualified technician.

Symptom	Remedy
You cannot turn on the power.	Check that power cable is firmly fastened.
	Check for damaged power cable and connector.
	Check battery for proper voltage output.
No picture appears.	Press the  /BRILL key several times to adjust the brilliance.
There is no response when a key is pressed.	Turn off and on the power. If no change, ask your dealer.
Position is not fixed within 90 seconds.	Check that antenna connector is firmly fastened.
	Check the number of satellites on Satellite Monitor display. If there are two or less, check for obstructions between antenna unit and satellites.
Position is wrong.	Check that the correct geodetic chart system is selected on the GPS Setting screen.
	Enter position offset on the GPS Setting screen.
Loran C/Decca TDs do not appear.	Check Loran C/Decca chain data on the Pos/TD Setup screen.
Loran C/Decca TDs are wrong.	Enter TD offset on the Pos/TD Setup screen.
Bearing is wrong.	Check Magnetic Variation on the Plotter Setup screen.

8.3 Displaying the Message Board

When an error occurs, a message and an alarm icon appear on the screen. The message board displays the error messages (see page 6-2) shown in table below.

Messages and meanings

Message	Meaning, remedy
GPS ERROR!	Request service.
GPS NO FIX!	No GPS signal. Check antenna cable.
RAM ERROR!	Request service.
ROM ERROR!	Request service.
BACKUP ERROR!	RAM data corrupted. Try to clear backup data.

8.4 Diagnostics

The diagnostic test checks the ROM, RAM, input data, GPS core, keyboard and LCD performance. The user can do the tests to help the service technician in troubleshooting.

1. Press the **MENU/ZOOM** key twice to show the menu.
2. Select [System], and press the **ENT** key.
3. Select [Self Test], and press the **ENT** key.



4. Select [System Test], and press the **ENT** key to start the test.
The results are individually displayed as OK or NG (No Good). If NG appears, try the test again. If NG re-appears, contact your dealer for advice.

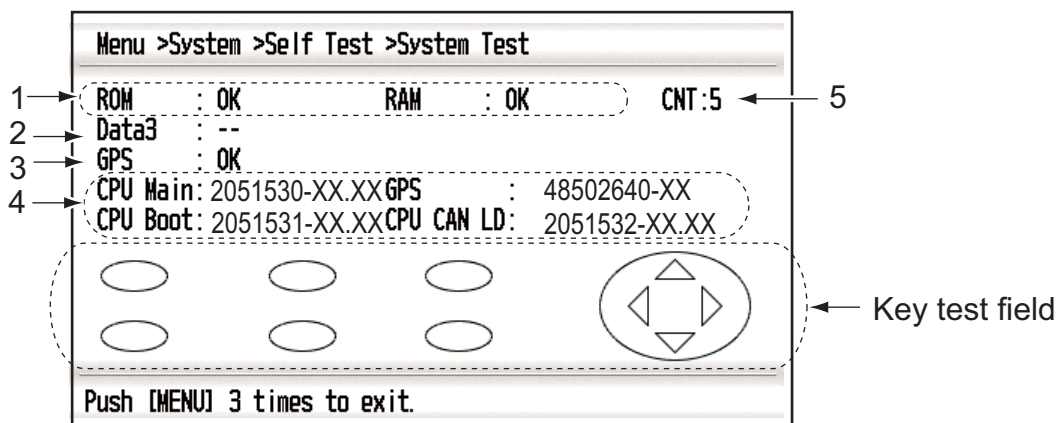

XX: Program version No.

No.	Test Items	Description
1	ROM, RAM test	Correct: "OK", Wrong: "NG"
2	Data3 test	"-" (This test is used at factory only.)
3	GPS test	Correct: "OK", Wrong: "NG"
4	Program version No.	The program version No. which is currently used appears.
5	CNT	Number of test repetition.

5. Press each key one by one.
The corresponded mark on the display turns red if the key is functioning properly.
6. Press the **MENU/ZOOM** key three times to close the test screen.
7. Select [LCD Test], and press the **ENT** key.
Each press of this key changes the LCD pattern in the sequence shown below.
Red→Green→Blue→Red (gradation)→Green (gradation)→Blue (gradation)→White→Black→White/Black (gradation)→return to System screen.
Note: To cancel the test, press the **MENU/ZOOM** key.
8. Press the **MENU/ZOOM** key twice to close the menu.

8.5 Clearing Data

You can clear GPS data, menu settings* and all backup data* to start afresh (*other than Language, Units and TD).

1. Press the **MENU/ZOOM** key twice to show the menu.
2. Select [System], and press the **ENT** key.
3. Select [Reset], and press the **ENT** key.

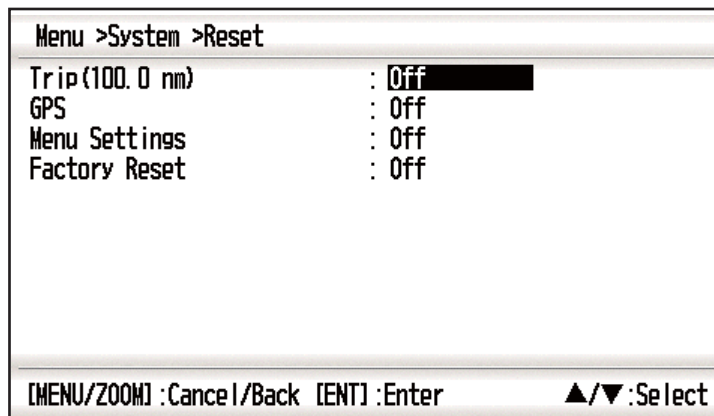

4. Select [GPS], [Menu Settings] or [Factory Reset], and press the **ENT** key.
5. Select [On], and press the **ENT** key.
6. Press ◀ to select [Yes], and press the **ENT** key.
[Menu Settings], [Factory Reset]: Go to Initial Setting screen. Select the language, then press **ENT** and **MENU/ZOOM** key in order.

9. INSTALLATION

9.1 Equipment Lists

Standard Supply

Name	Type	Code No.	Qty	Remarks
Receiver unit	GP-33	-	1	
Antenna Unit	GPA-017	-	1	w/10 m cable
Installation Materials	CP20-03300	-	1 set	-M12-05BM+05BF-060 -CP20-03310
Accessories	FP20-01200	-	1 set	See the packing list at the back of this manual.

Optional Supply

Name	Type	Qty	Remarks
Junction Box	FI-5002	000-010-765	
Cable Assy.	FRU-10BFFM-02M	001-112-970-10	
Right Angle Antenna Base	NO.13-QA330	001-111-910-10	For mounting the antenna unit, select one.(See the installation procedure at the back of this manual.)
L-type Antenna Base	NO.13-QA310	001-111-900-10	
Handrail Antenna Base	NO.13-RC5160	001-111-920-10	
Mast Mounting Kit	CP20-01111	004-365-780	
NMEA Connector	SS-050505-FMF-TS001	000-168-603-10	CAN bus distributor, micro style
	NC-050505FMF-TS001	000-160-507-10	CAN bus distributor, mini style
Cover-Up Bezel	OP20-38	001-156-750	Kit for upgrading GP-32 to GP-33

9.2 Installation of Receiver Unit

9.2.1 Installation consideration

The receiver unit can be installed on a desktop, underside of table or in a panel. Refer to the outline drawings at the end of this manual for installation instructions. When selecting a mounting location, keep in mind the following points:

- Locate the unit away from exhaust pipes and vents.

9. INSTALLATION

- The mounting location should be well ventilated.
- Mount the unit where shock and vibration are minimal.
- Locate the unit away from equipment which generates electromagnetic fields such as a motor or generator.
- Allow sufficient maintenance space at the sides and rear of the unit and leave sufficient slack in cables, to facilitate maintenance and servicing.
- Observe compass safe distances noted on page ii to prevent interference to a magnetic compass.
- Locate the unit away from direct sunlight. An LCD may black out if it is exposed to direct sunlight for a long time.
- The optimal viewing distance is 0.6 m. Select a suitable mounting location considering the distance.

9.2.2 Desktop and underside of table mount

1. Unscrew knobs to dismount the receiver unit from the hanger.
2. Prepare four pilot holes (for 5x20 self-tapping screws) at the mounting location.
3. Fix the hanger to the mounting location with four self-tapping screws (5x20, supplied).
4. Attach cables to the back of the receiver unit (see section 9.4).
5. Set the receiver unit to the hanger, and fasten knobs to fix it.

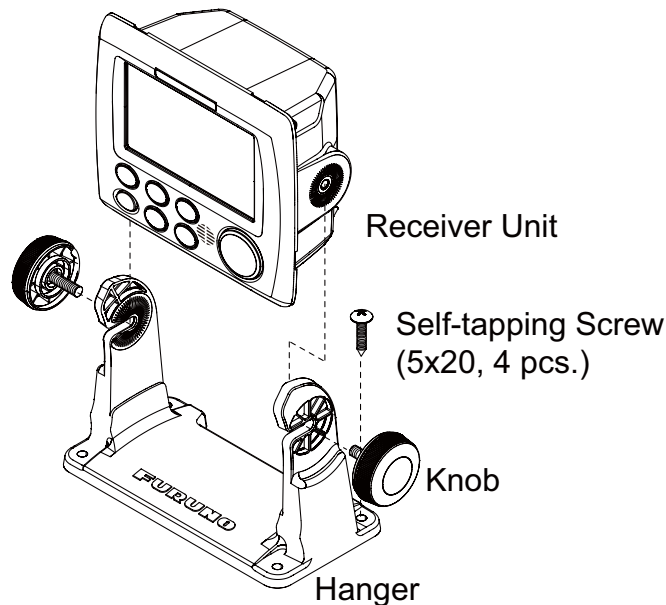

9.2.3 Flush mount

1. Using the template (supplied), cut out a hole in the mounting location.
2. Prepare four pilot holes (for 3x20 self-tapping screws) at the mounting location.
3. Unscrew knobs to dismount the receiver unit from the hanger.
This hanger can be discarded.
4. Remove the front panel from the receiver unit by unfastening the catches at the rear of the panel by hands, in the order shown in the figure below.

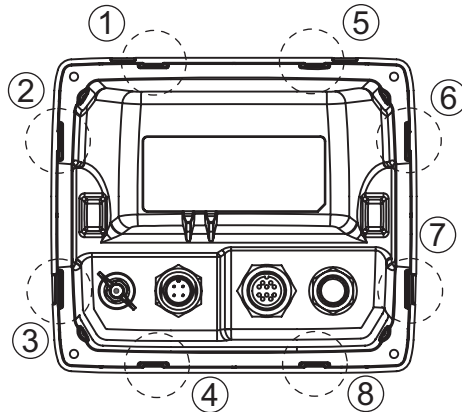

5. Attach the mount cushion (sponge) to the hole made at step 1, or receiver unit.
6. Connect cables to the back of the receiver unit (see section 9.4).
7. Use four self-tapping screws (3x20, supplied) to fasten the receiver unit to the mounting location, and re-attach the front panel.

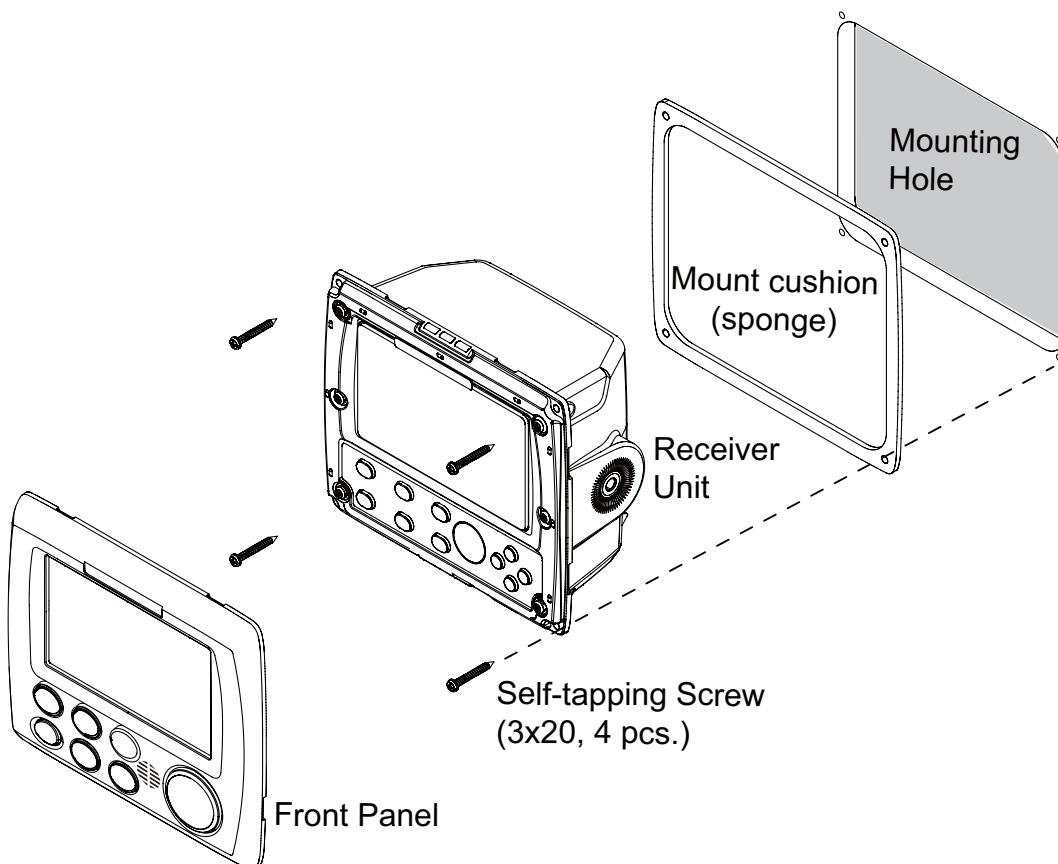

9. INSTALLATION

Note: When removing the equipment from the flush mounted location, use the remover (supplied) to remove the panel as shown below.

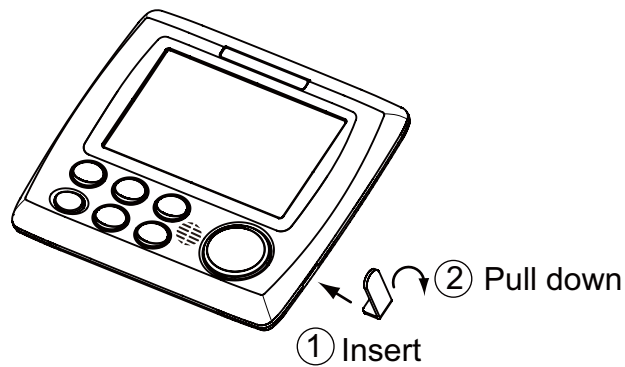

9.3 Installation of Antenna Unit

Install the antenna unit referring to the antenna installation diagram at the back of this manual. When choosing a mounting location for the antenna unit, keep in mind the following points:

- Select a location out of the radar beam. The radar beam will obstruct or prevent reception of the GPS signal.
- The location should be well away from a VHF/UHF antenna. A GPS receiver is interfered by a harmonic wave of a VHF/UHF antenna.
- There should be no interfering object within the line-of-sight to the satellites. An object within line-of-sight to satellites, for example, a mast, may block reception or prolong acquisition time.
- Mount the antenna unit as high as possible to keep it free from interfering objects and water spray. Freezing water can interrupt reception of the GPS satellite signal.

Note 1: Do not shorten the antenna cable.

Note 2: If the antenna cable is to be passed through a hole which is not large enough to pass the connector, unfasten the connector with a needle nose pliers and 3/8-inch open-end wrench. Refasten it as shown below, after running the cable through the hole.

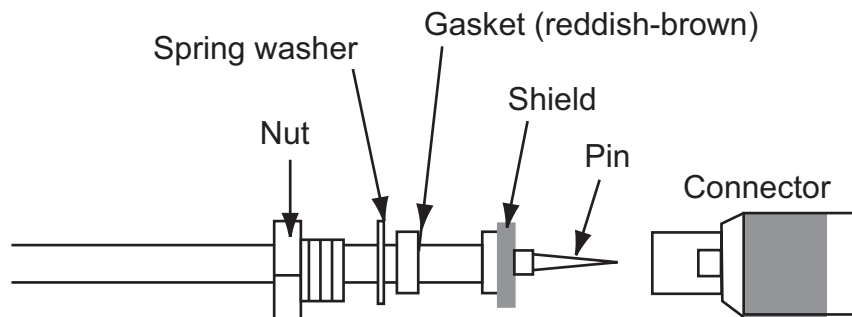

9.4 Wiring

When no CAN bus equipment is connected

When connecting no CAN bus equipment, use the red and black-colored cores of M12-05BM+05BF-060 cable to connect to the 12-24 VDC switch board. (For other cores, cut them and tape individually.)

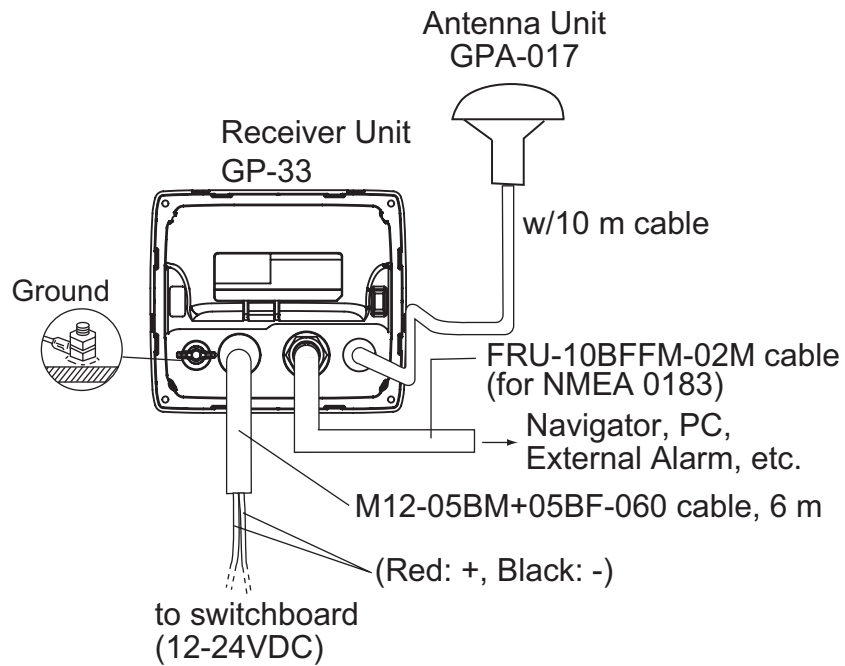

Connection with the optional junction box FI-5002

Detailed information for the service technician about CAN bus wiring is in the document titled “Furuno CAN bus Network Design Guide (TIE-00170-*)” separately.

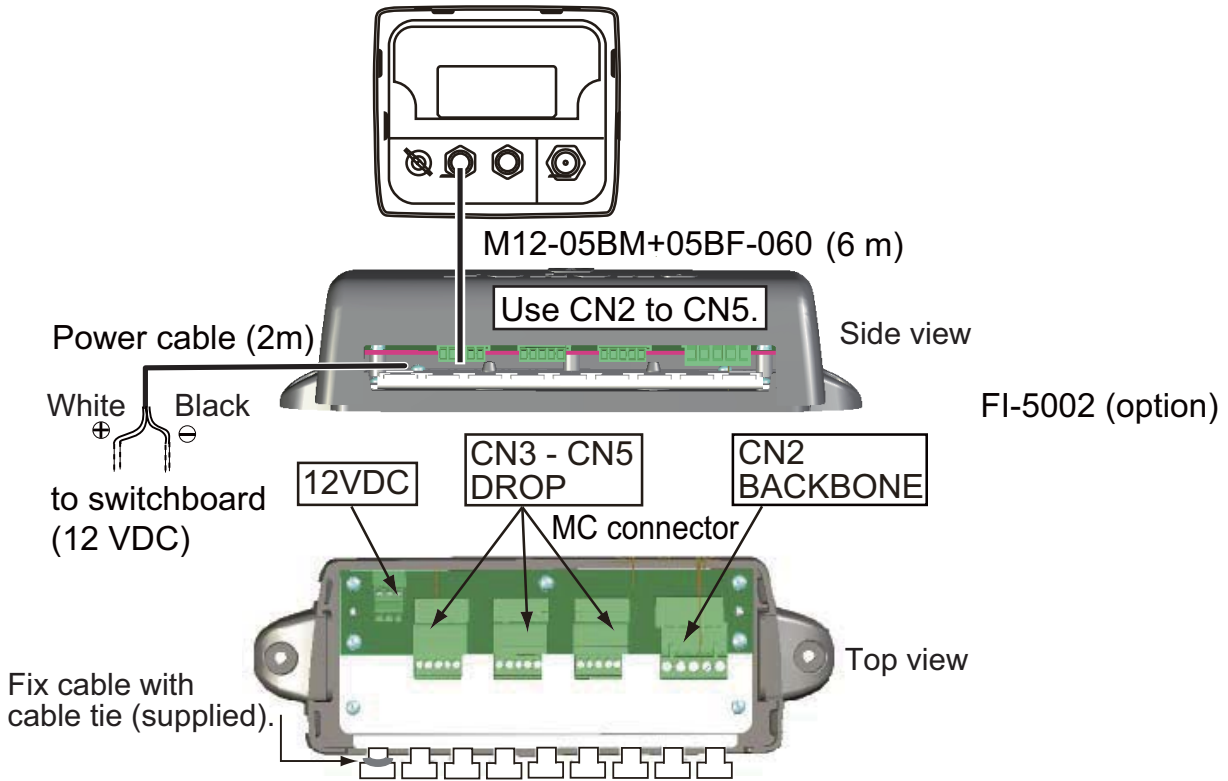

- Fabrication of M12-05BM+05BF-060 cable and MC connector

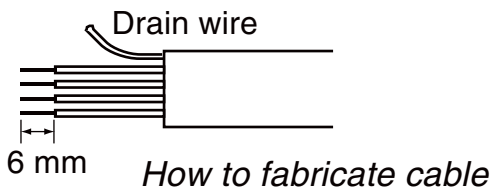

Drain	#1
Red	#2
Black	#3
White	#4
Blue	#5

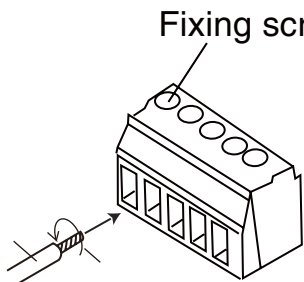

1. Twist wires.
2. Loosen fixing screw in plug.
3. Insert wire into hole.
4. Tighten fixing screw.
5. Pull wire to confirm the connection.

How to insert wire

Terminator

- When connecting to backbone cable

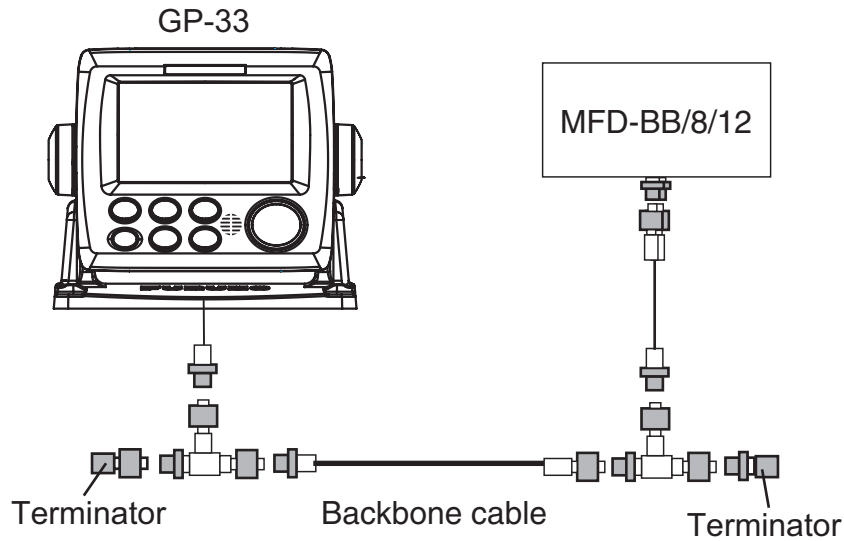

Attach the following terminators to both ends of the backbone cable.

Name	Type	Code No.	Remarks
Terminator (male)	LTWMN-05AMMT-SL8001	000-160-508-10	Mini connector
Terminator (female)	LTWMN-05AFFT-SL8001	000-160-509-10	Mini connector
Terminator (male)	LTWMC-05BMMT-SL8001	000-168-604-10	Micro connector
Terminator (female)	LTWMC-05BFFT-SL8001	000-168-605-10	Micro connector

When connecting to the optional junction box FI-5002

There are two terminal resistors (R1 and R2) inside the FI-5002.

- No backbone cable is connected: Set both R1 and R2 to "ON".
- Backbone cable is connected: Set a resistor to "ON".
- Two backbone cables are connected: Set both R1 and R2 to "OFF".

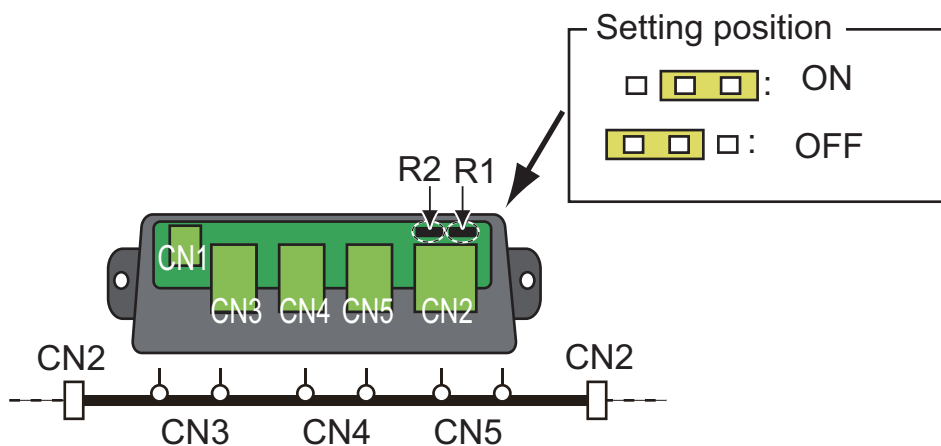

9.5 Language Setting

When you first turn the power on after installation, you are asked the language to use on the equipment. Press ▲ or ▼ to select the language, and press the ENT key.

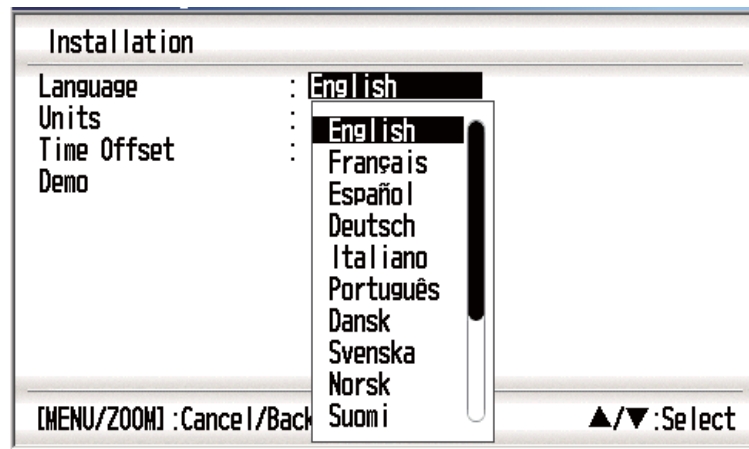

9.6 Input/Output Data

This equipment inputs/outputs NMEA0183 or CAN bus data shown below. Note that NMEA 0183 version (2.0 or 3.0) can be selected from the I/O setup screen.

Data 1: CAN bus port (input)

PGN	Description	Remark
059904	ISO Request	
060928	ISO Address Claim	
061184 #4=0	Self Test Group Function	
065286	Proprietary; Boot State Request	
126208	Request Group Function	
	Command Group Function	
126720 #4=1	Memory Clear Group Function	
126720 #4=2	Reset Group Function	

Data 1: CAN bus port (output)

PGN	Description	Output cycle
059392	ISO Acknowledgement	N/A
060928	ISO Address Claim	N/A
061184	Self Test Group Function	N/A
126208	NMEA-Acknowledge group function	N/A
126464	PGN List Transmit and Received PGNs Group Function	N/A
126720-1	Memory Clear Group Function	N/A
126720-2	Reset Group Function	N/A
126992	System Time	1000
126996	Product Information	N/A
127258	Magnetic Variation	1000
129026	COG & SOG, Rapid Update	1000
129029	GNSS Position Data	1000
129033	Time & Date	1000
129044	Datum	10000
129283	Cross Track Error	1000
129284	Navigation Data	1000
129285	Navigation -Route/WP information	N/A
129538	GNSS Control Status	N/A
129539	GNSS DOPs	1000
129540	GNSS Sats in View	1000
130822	Unit Division Code	N/A
130823	Browser Control Status	N/A

Data 2/Data 3: NMEA Output Sentence

Format**	REM1	REM2	AP	GPS
AAM*			ON	
APB*			ON	
BOD*			ON	
BWC*		ON	ON	
BWR*		ON	ON	
DTM	ON	ON		
GGA	ON	ON		ON
GLL	ON		ON	
GSA				ON
GSV				ON
RMB*	ON	ON		
RMC	ON	ON		
VTG	ON	ON	ON	ON
XTE			ON	
ZDA	ON	ON	ON	
RTE	For PC only. (See Chapter 7.)			

REM1/REM2: Radar, echo sounder, etc.

AP: Autopilot

*: Not output when no waypoint is set.

** : Talker; GP

Output setting

1. Press the **MENU/ZOOM** key twice to show the main menu.
2. Select [I/O Setup], then press the **ENT** key.
3. Select [Data 2], [Data 3] or [NMEA0183 Version] depending on the equipment connected.
4. Press the **ENT** key. One of the following screens appears depending on the item selected at step 3.

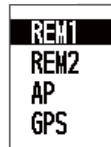

"Data2/Data3*"



"NMEA0183 Version"

*: When selecting [DGPS] or [Auto] in the [WAAS/DGPS] - [Mode] menu, [Beacon] is grayed out in the [Data3] menu.

5. Press ▲ or ▼ to select the option.
 REM1, 2: Output data to radar, echo sounder.
 AP: Output data to an autopilot.
 GPS: Output GPS data (used for the service)
 2.0, 3.0: select the NMEA version of external equipment. If you are unsure of the version number, try both and select the one which successfully outputs data.
6. Press the **ENT** key.
7. Press the **MENU/ZOOM** key twice to close the menu.

9. INSTALLATION

This page is intentionally left blank.

APPENDIX 1 MENU TREE

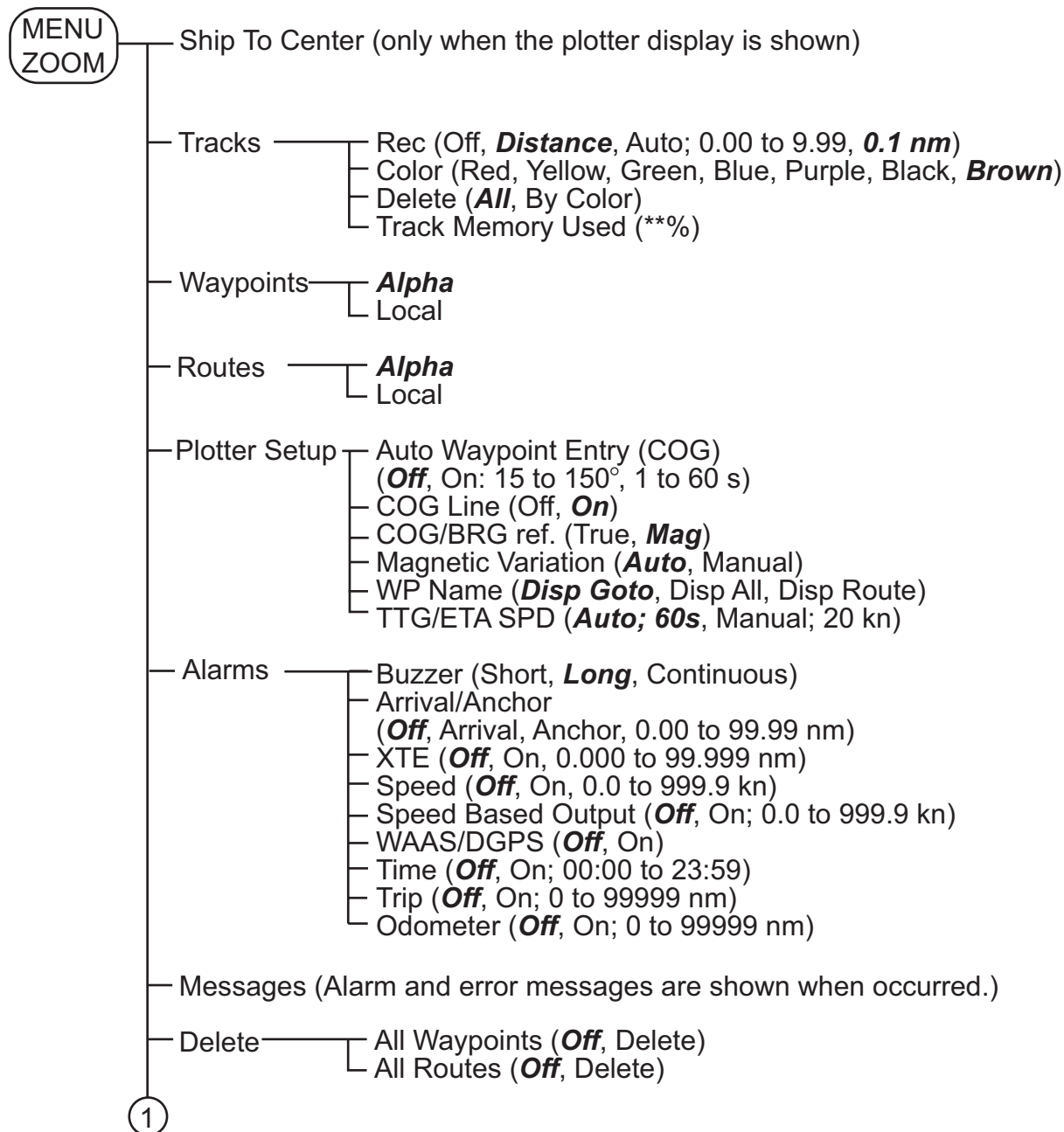

Bold: Default setting

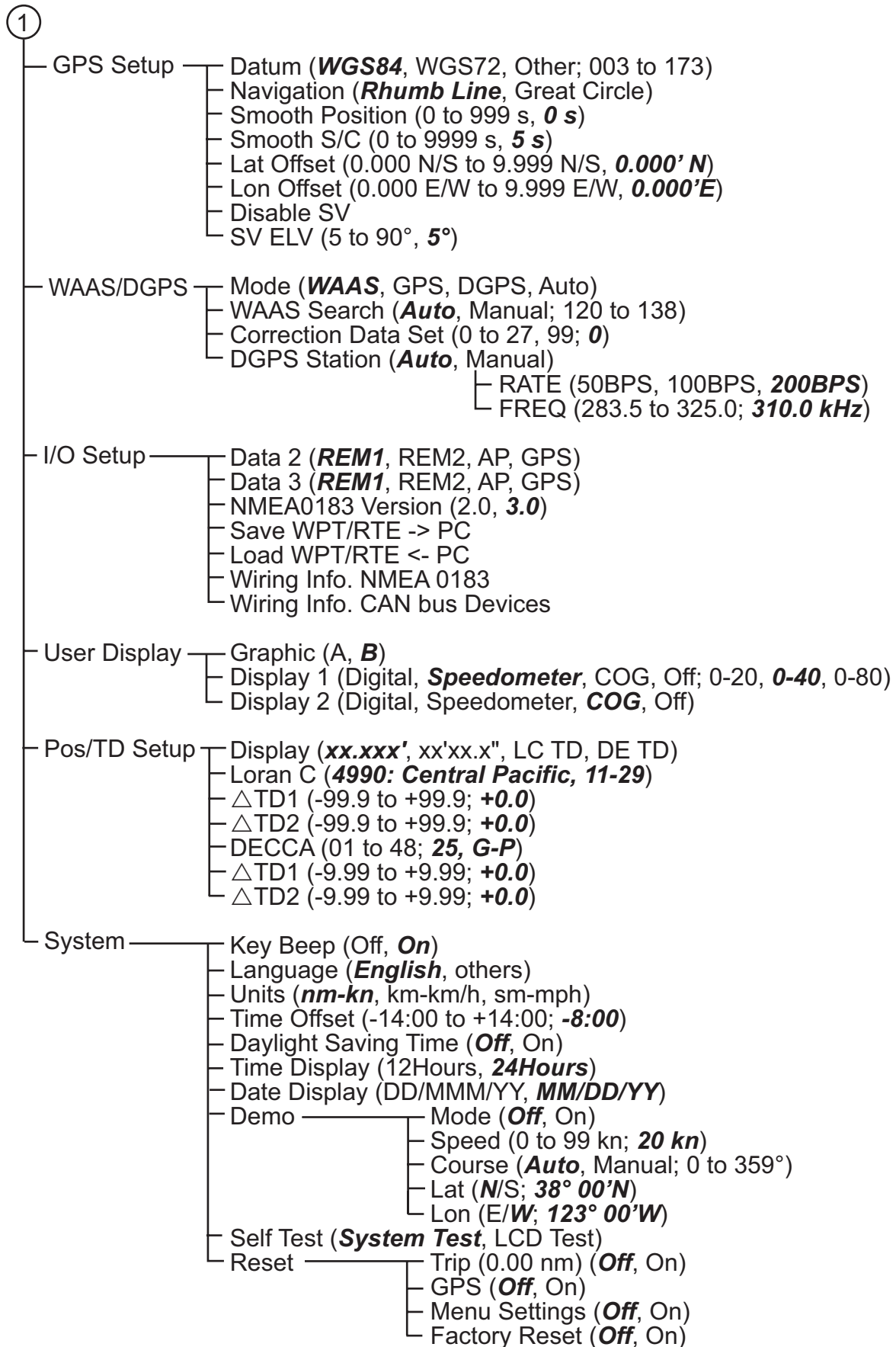

APPENDIX 2 WHAT IS WAAS?

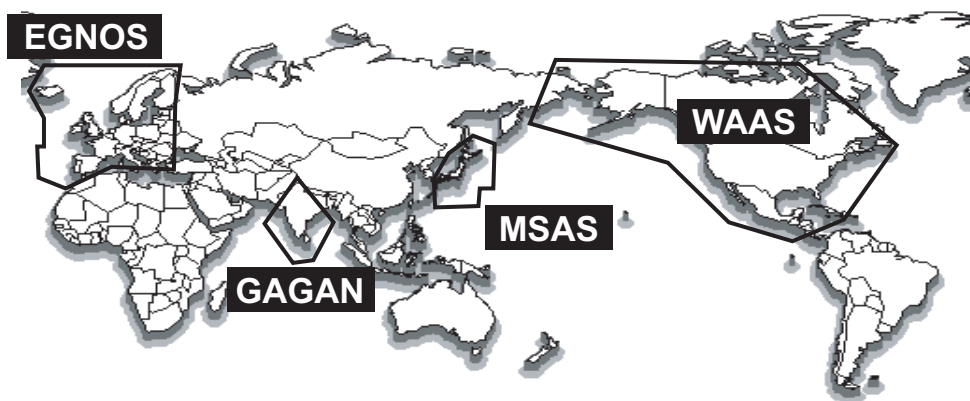

WAAS, available in North America, is a provider in the worldwide SBAS (Satellite Based Augmentation System) navigation system. SBAS provides GPS signal corrections to SBAS users, for even better position accuracy, typically better than three meters. There are three more SBAS providers, MSAS (Multi-Functional Satellite Augmentation System) for Japan, EGNOS (Euro Geostationary Navigation Overlay Service) for Europe and GAGAN (GPS And GEO Augmented Navigation) for India. The illustration below shows the coverage area. (Accuracy may be affected when using a GEO satellite not within your current location.) This manual uses “WAAS” for these three providers generically.



Provider	Satellite type	Longitude	Satellite No.
WAAS	Intelsat Galaxy XV	133°W	135
	TeleSat Anik F1R	107.3°W	138
	Inmarsat-4-F3	98°W	133
EGNOS	Inmarsat-3-F2/AOR-E	15.5°W	120
	Artemis	21.5°E	124
	Inmarsat-4-F2	25°E	126
MSAS	MTSAT-1R	140°E	129
	MTSAT-2	145°E	137
GAGAN	Inmarsat-4-F1	64°E	127

APPENDIX 3 LIST OF TERMS

The following table shows the terms used in GP-33.

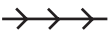
Terms/Symbols	Meaning	Terms/Symbols	Meaning
	Waypoints	Lat	Latitude
	Own Boat	Lon	Longitude
"M"	Man Overboard	LC	Loran-C
	Shortest course to the destination	M, Mag	Magnetic
+	Cursor	MAR	March
%	Percentage	MAY	May
2D, 3D	2D/3D GPS position fix	MM (MMM)	Month
D2D, D3D	2D/3D DGPS position fix	mph	mile per hour
W2D, W3D	2D/3D WAAS position fix	N	North
AP	Autopilot	nm	Nautical Mile
APR	April	NMEA	National Marine Electronics Association
AUG	August	NOV	November
Auto	Automatic	OCT	October
Brill	Brilliance	ODO	Odometer
BRG	Bearing	PDOP	Position Dilution Of Precision
Cmnt	Comment	Pos	Position
COG	Course Over Ground	ref.	Reference
DD	Day	QP	Quick Point
DE	Decca	REM	Remote
DEC	December	RNG	Range
Demo, SIM	Demonstration Mode	RTE, RT	Route
Disp	Display	S	South
DOP	Dilution Of Precision	s	seconds
E	East	S/C	Speed/Course
ELV	Elevation	SEP	September
ENT	Enter	sm	Statute Mile
ETA	Estimated Time of Arrival	SOG	Speed Over Ground
FEB	February	SPD	Speed
G	Go to	T	True
GPS	Global Positioning System	TD	Time Difference
I/O	Input/Output	TTG	Time To Go
HDOP	Horizontal Dilution Of Precision	Volt	Voltage
JAN	January	W	West
JUL	July	WAAS	Wide Area Augmentation System
JUN	June	WPT, WP	Waypoint
km	kilometer	XTE	Cross Track Error
kn	knot	YY	Year

APPENDIX 4 GEODETIC CHART LIST

001: WGS84		
002: WGS72		
003: TOKYO	: Mean Value (Japan, Korea & Okinawa)	
004: NORTH AMERICAN 1927	: Mean Value (CONUS)	
005: EUROPEAN 1950	: Mean Value	
006: AUSTRALIAN GEODETIC 1984	: Australia & Tasmania	
007: ADINDAN	: Mean Value (Ethiopia & Sudan)	
008: ADINDAN	: Ethiopia	
009: ADINDAN	: Mali	
010: ADINDAN	: Senegal	
011: ADINDAN	: Sudan	
012: AFG	: Somalia	
013: AIN EL ABD 1970	: Bahrain Is.	
014: ANNA 1 ASTRO 1965	: Cocos Is.	
015: ARC 1950	: Mean Value	
016: ARC 1950	: Botswana	
017: ARC 1950	: Lesotho	
018: ARC 1950	: Malawi	
019: ARC 1950	: Swaziland	
020: ARC 1950	: Zaire	
021: ARC 1950	: Zambia	
022: ARC 1950	: Zimbabwe	
023: ARC 1960	: Mean Value (Kenya & Tanzania)	
024: ARC 1960	: Kenya	
025: ARC 1960	: Tanzania	
026: ASCENSION IS. 1958	: Ascension Is.	
027: ASTRO BEACON "E"	: Iwo Jima Is.	
028: ASTRO B4 SOR. ATOLL	: Tern Is.	
029: ASTRO POS 71/4	: St. Helena Is.	
030: ASTRONOMIC STATION 1952	: Marcus Is.	
031: AUSTRALIAN GEODETIC 1966	: Australia & Tasmania	
032: BELLEVUE (IGN)	: Efate & Erromango Is.	
033: BERMUDA 1957	: Bermuda Is.	
034: BOGOTA OBSERVATORY	: Columbia	
035: CAMPO INCHAUSPE	: Argentina	
036: CANTON IS. 1966	: Phoenix Is.	
037: CAPE	: South Africa	
038: CAPE CANAVERAL	: Mean Value (Florida & Bahama Is.)	
039: CARTHAGE	: Tunisia	
040: CHATHAM 1971	: Chatham Is. (New Zealand)	
041: CHUA ASTRO	: Paraguay	
042: CORREGO ALEGRE	: Brazil	
043: DJAKARTA (BATAVIA)	: Sumatra Is. (Indonesia)	
044: DOS 1968	: Gizo Is. (New Georgia Is.)	
045: EASTER IS. 1967	: Easter Is.	
046: EUROPEAN 1950 (Cont'd)	: Western Europe	
047: EUROPEAN 1950 (Cont'd)	: Cyprus	
048: EUROPEAN 1950 (Cont'd)	: Egypt	
049: EUROPEAN 1950 (Cont'd)	: England, Scotland, Channel & Shetland Is.	
050: EUROPEAN 1950 (Cont'd)	: England, Ireland, Scotland & Shetland Is.	
051: EUROPEAN 1950 (Cont'd)	: Greece	
052: EUROPEAN 1950 (Cont'd)	: Iran	
053: EUROPEAN 1950 (Cont'd)	: Italy, Sardinia	
054: EUROPEAN 1950 (Cont'd)	: Italy, Sicily	
055: EUROPEAN 1950 (Cont'd)	: Norway & Finland	
056: EUROPEAN 1950 (Cont'd)	: Portugal & Spain	
057: EUROPEAN 1979	: Mean Value	
058: GANDAJIKA BASE	: Republic of Maldives	
059: GEODETIC DATUM 1949	: New Zealand	
060: GUAM 1963	: Guam Is.	
061: GUX 1 ASTRO	: Guadalcanal Is.	
062: HJORSEY 1955	: Iceland	
063: HONG KONG 1963	: Hong Kong	
064: INDIAN	: Thailand & Vietnam	
065: INDIAN	: Bangladesh, India & Nepal	
066: IRELAND 1965	: Ireland	
067: ISTS 073 ASTRO 1969	: Diego Garcia	
068: JOHNSTON IS. 1961	: Johnston Is.	
069: KANDAWALA	: Sri Lanka	
070: KERGUÉLEN IS.	: Kerguelen Is.	
071: KERTAU 1948	: West Malaysia & Singapore	
072: LA REUNION	: Mascarene Is.	
073: L. C. 5 ASTRO	: Cayman Brac Is.	
074: LIBERIA 1964	: Liberia	
075: LUZON	: Philippines (excl. Mindanao Is.)	
076: LUZON	: Mindanao Is.	
077: MAHE 1971	: Mahe Is.	
078: MARCO ASTRO	: Salvage Islands	
079: MASSAWA	: Eritrea (Ethiopia)	
080: MERCHICH	: Morocco	
081: MIDWAY ASTRO 1961	: Midway Is.	
082: MINNA	: Nigeria	
083: NAHRWAN	: Masirah Is. (Oman)	
084: NAHRWAN	: United Arab Emirates	
085: NAHRWAN	: Saudi Arabia	
086: NAMIBIA	: Namibia	
087: MAPARIMA, BWI	: Trinidad & Tobago	
088: NORTH AMERICAN 1927	: Western United States	
089: NORTH AMERICAN 1927	: Eastern United States	
090: NORTH AMERICAN 1927	: Alaska	
091: NORTH AMERICAN 1927	: Bahamas (excl. San Salvador Is.)	
092: NORTH AMERICAN 1927	: Bahamas, San Salvador Is.	
093: NORTH AMERICAN 1927 (Cont'd)	: Canada (incl. Newfoundland Is.)	
094: NORTH AMERICAN 1927 (Cont'd)	: Alberta & British Columbia	
095: NORTH AMERICAN 1927 (Cont'd)	: East Canada	
096: NORTH AMERICAN 1927 (Cont'd)	: Manitoba & Ontario	
097: NORTH AMERICAN 1927 (Cont'd)	: Northwest Territories & Saskatchewan	
098: NORTH AMERICAN 1927 (Cont'd)	: Yukon	
099: NORTH AMERICAN 1927 (Cont'd)	: Canal Zone	
100: NORTH AMERICAN 1927 (Cont'd)	: Caribbean	
101: NORTH AMERICAN 1927 (Cont'd)	: Central America	
102: NORTH AMERICAN 1927 (Cont'd)	: Cuba	
103: NORTH AMERICAN 1927 (Cont'd)	: Greenland	
104: NORTH AMERICAN 1927 (Cont'd)	: Mexico	
105: NORTH AMERICAN 1983	: Alaska	
106: NORTH AMERICAN 1983	: Canada	
107: NORTH AMERICAN 1983	: CONUS	
108: NORTH AMERICAN 1983	: Mexico, Central America	
109: OBSERVATORIO 1966	: Corvo & Flores Is. (Azores)	
110: OLD EGYPTIAN 1930	: Egypt	
111: OLD HAWAIIAN	: Mean Value	
112: OLD HAWAIIAN	: Hawaii	
113: OLD HAWAIIAN	: Kauai	
114: OLD HAWAIIAN	: Maui	
115: OLD HAWAIIAN	: Oahu	
116: OMAN	: Oman	
117: ORDNANCE SURVEY OF GREAT BRITAIN 1936	: Mean Value	
118: ORDNANCE SURVEY OF GREAT BRITAIN 1936	: England	
119: ORDNANCE SURVEY OF GREAT BRITAIN 1936	: England, Isle of Man & Wales	
120: ORDNANCE SURVEY OF GREAT BRITAIN 1936	: Scotland & Shetland Is.	
121: ORDNANCE SURVEY OF GREAT BRITAIN 1936	: Wales	
122: PICO DE LAS NIVIAS	: Canary Is.	
123: PITCAIRN ASTRO 1967	: Pitcairn Is.	
124: PROVISIONAL SOUTH CHILEAN 1963	: South Chile (near 53°S)	
125: PROVISIONAL SOUTH AMERICAN 1956	: Mean Value	
126: PROVISIONAL SOUTH AMERICAN 1956	: Bolivia	
127: PROVISIONAL SOUTH AMERICAN 1956	: Chile-Northern Chile (near 19°S)	
128: PROVISIONAL SOUTH AMERICAN 1956	: Chile-Southern Chile (near 43°S)	
129: PROVISIONAL SOUTH AMERICAN 1956	: Columbia	
130: PROVISIONAL SOUTH AMERICAN 1956	: Ecuador	
131: PROVISIONAL SOUTH AMERICAN 1956	: Guyana	
132: PROVISIONAL SOUTH AMERICAN 1956	: Peru	
133: PROVISIONAL SOUTH AMERICAN 1956	: Venezuela	
134: PUERTO RICO	: Puerto Rico & Virgin Is.	
135: QATAR NATIONAL	: Qatar	
136: QORNOQ	: South Greenland	
137: ROME 1940	: Sardinia Is.	
138: SANTA BRAZ	: Sao Miguel, Santa Maria Is. (Azores)	
139: SANTO (DOS)	: Espirito Santo Is.	
140: SAPPER HILL 1943	: East Falkland Is.	
141: SOUTH AMERICAN 1969	: Mean Value	
142: SOUTH AMERICAN 1969	: Argentina	
143: SOUTH AMERICAN 1969	: Bolivia	
144: SOUTH AMERICAN 1969	: Brazil	
145: SOUTH AMERICAN 1969	: Chile	
146: SOUTH AMERICAN 1969	: Columbia	
147: SOUTH AMERICAN 1969	: Ecuador	
148: SOUTH AMERICAN 1969	: Guyana	
149: SOUTH AMERICAN 1969	: Paraguay	
150: SOUTH AMERICAN 1969	: Peru	
151: SOUTH AMERICAN 1969	: Trinidad & Tobago	
152: SOUTH AMERICAN 1969	: Venezuela	
153: SOUTH ASIA	: Singapore	
154: SOUTHEAST BASE	: Porto Santo & Madeira Is.	
155: SOUTHWEST BASE	: Faial, Graciosa, Pico, Sao Jorge & Terceira Is.	
156: TIMBALAI 1948	: Brunei & East Malaysia (Sarawak & Sabah)	
157: TOKYO	: Japan	
158: TOKYO	: Korea	
159: TOKYO	: Okinawa	
160: TRISTAN ASTRO 1968	: Tristan da Cunha	
161: VITI LEVU 1916	: Viti Levu Is. (Fiji Is.)	
162: WAKE-ENIWETOK 1960	: Marshall Is.	
163: ZANDERIJ	: Surinam	
164: BUKIT RIMPAH	: Bangka & Belitung Is. (Indonesia)	
165: CAMP AREA ASTRO	: Camp Morduro Area, Antarctica	
166: G. SEGARA	: Kalimantan Is. (Indonesia)	
167: HERAT NORTH	: Afghanistan	
168: HU-TZU-SHAN	: Taiwan	
169: TANANARIVE OBSERVATORY 1925	: Madagascar	
170: YACARE	: Uruguay	
171: RT-90	: Sweden	
172: PULKOVO 1942	: Russia	
173: FINNISH KKK	: Finland	

This page is intentionally left blank.

**SPECIFICATIONS OF GPS NAVIGATOR
GP-33**

1 GENERAL

1.1	Display system	4.3-inch color LCD
1.2	Effective area	95.04 x 53.85 mm, 480 x 272 dots (WQVGA)
1.3	Projection	Mercator
1.4	Display mode	Plotter, Highway, Steering, NAV data, Satellite monitor, User
1.5	Memory capacity	Track: 3,000 pts, Waypoint: 10,000 pts w/ comment (13 character)
1.6	Storage capacity	100 routes w/ 30 waypoint each
1.7	Alarms	Arrival and anchor watch, Cross track error, Odometer alarm, Ship's speed, Timer, Trip, WAAS
1.8	Display scale	
	Plotter display	0.02/0.05/0.1/0.2/0.5/1/2/5/10/20/40/80/160/320 NM
	Highway display	0.2/0.4/0.8/1/2/4/8/16 NM

2 GPS RECEIVER

2.1	Receiving channels	
	GPS	12 channels parallel, 12 satellites tracking
	WAAS	2 channel
2.2	Rx frequency	1575.42 MHz
2.3	Rx code	C/A code, WAAS
2.4	Position accuracy (95% of the time, 2drms)	
	GPS	10 m approx.
	DGPS	5 m approx. (external data required)
	WAAS	3 m approx.
	MSAS	7 m approx.
2.5	Tracking velocity	999.9 kn
2.6	Position fixing time	Within 90 s (cold start)
2.7	Position update interval	1 s

3 INTERFACE

3.1	Number of port	CAN bus: 1 port, NMEA0183: 2 ports
3.2	Serial output	NMEA0183 Ver2.0/3.0 (current loop and RS-232C)
	Data sentences	AAM, APB, BOD, BWC, BWR, DTM, GGA, GLL, GSA, GSV, RMB, RMC, RTE, VTG, XTE, ZDA
3.3	DGPS data input	RTCM SC-104 Ver2.1
3.4	CAN bus PGN (NMEA2000)	
	Input	059904, 060928, 061184, 065286, 126208/720
	Output	059392, 060928, 061184, 126208/464/720/992/996, 127258, 129026/029/033/044/283/284/285/538/539/540, 130822/823
3.5	Contact signal	Event switch (MOB input), Speed alarm (output)

4 POWER SUPPLY

15 VDC: LEN7 (CAN bus)

12-24 VDC: 0.24-0.12 A (Non CAN bus)

5 ENVIRONMENTAL CONDITION

5.1 Ambient temperature

Antenna unit -25°C to +70°C

Receiver unit -15°C to +55°C

5.2 Relative humidity 93% at 40°C

5.3 Degree of protection IP56

5.4 Vibration IEC 60945

6 UNIT COLOR

6.1 Antenna unit N9.5

6.2 Receiver unit N2.5

FURUNO

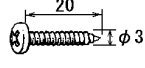
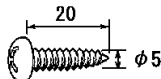
CODE NO.		001-087-240-00 **	20BE-X-9401 -1		
TYPE		GP20-03310	1/1		
工事材料表		GP-33/RD-33			
INSTALLATION MATERIALS					
番号 NO.	名称 NAME	略図 OUTLINE	型名/規格 DESCRIPTIONS	数量 Q'TY	用途/備考 REMARKS
1	+ハネタビ°ンネジ° 1シユ SELF-TAPPING SCREW		3X20 SUS304	4	
			CODE NO.		
2	+トラスタビ°ンネジ° 1シユ SELF-TAPPING SCREW		5X20 SUS304	4	
			CODE NO.		

C4458-M01-B

FURUNO

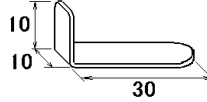
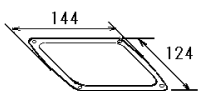
CODE NO.		001-087-250-00 **	20BE-X-9501 -2		
TYPE		FP20-01200	1/1		
付属品表		GP-33/RD-33			
ACCESSORIES					
番号 NO.	名称 NAME	略図 OUTLINE	型名/規格 DESCRIPTIONS	数量 Q'TY	用途/備考 REMARKS
1	ハ°ネリム-ハ° PANEL REMOVER		19-028-3124-1	1	
			CODE NO.		
2	F_MOUNT CUSHION F_MOUNT CUSHION		20-032-1064-1	1	
			CODE NO.		

C4458-F01-C

コード番号末尾の[**]は、選択品の代表コードを表します。
CODE NUMBER ENDING WITH "**" INDICATES THE CODE NUMBER OF REPRESENTATIVE MATERIAL.

型式/コード番号が2段の場合、下段より上段に代わる過渡期品であり、どちらかが入っています。なお、品質は変わりません。

TWO TYPES AND CODES MAY BE LISTED FOR AN ITEM. THE LOWER PRODUCT MAY BE SHIPPED IN PLACE OF THE UPPER PRODUCT. QUALITY IS THE SAME.

(略図の寸法は、参考値です。 DIMENSIONS IN DRAWING FOR REFERENCE ONLY.)

FURUNO ELECTRIC CO., LTD.



表 1 TABLE 1

寸法区分 (mm) DIMENSION	公差 (mm) TOLERANCE
L ≤ 50	±1.5
50 < L ≤ 100	±2.5
100 < L ≤ 500	±3

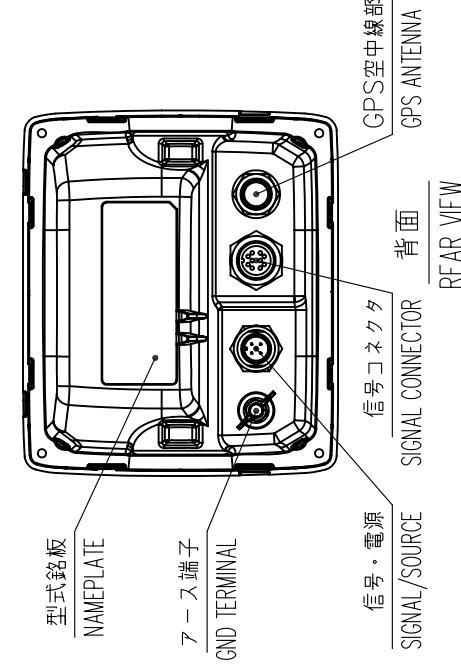
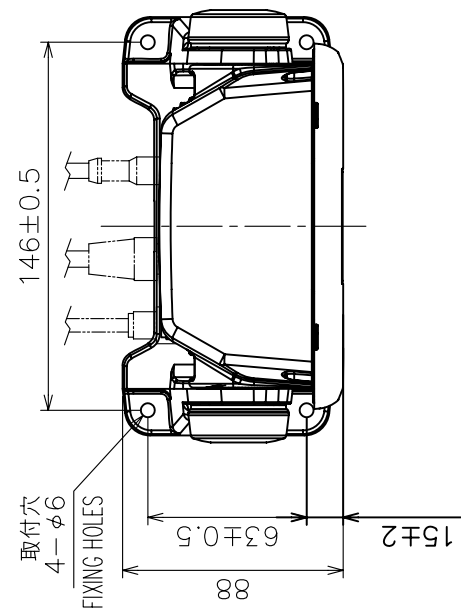
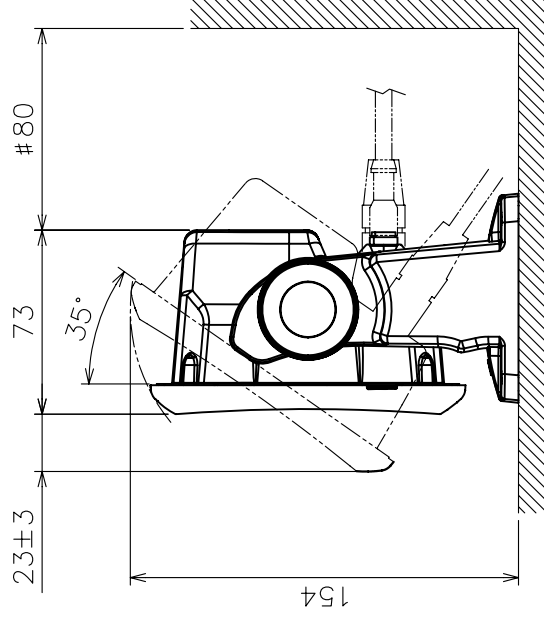
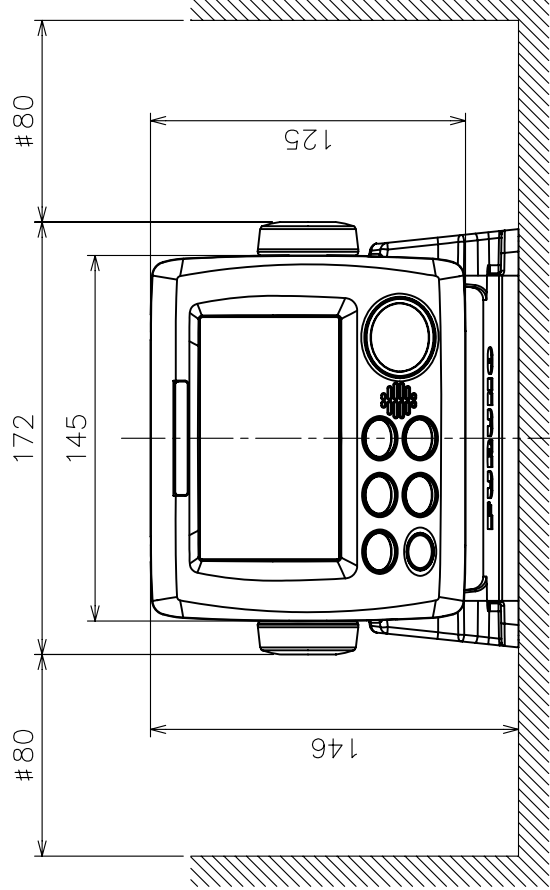

注記

- 1) 指定外寸公差は表 1 による。
- 2) #印寸法は、最小サービスクリアランスとする。
- 3) 取付にはトラスタップピンネジ呼び径5×20を使用のこと。

NOTE

1. TABLE 1 INDICATES TOLERANCE OF DIMENSIONS WHICH IS NOT SPECIFIED.
2. # MINIMUM SERVICE CLEARANCE.
3. USE TAPPING SCREWS φ5x20 FOR FIXING THE UNIT.

DRAWN	18/Oct/2010	I. YAMASAKI	TITLE	GP-33
CHECKED	19/Oct/2010	I. TAKAHASHI	名称	受信演算部 (卓上装備)
APPROVED	19/Oct/2010	Y. NISHIYAMA	外寸図	
SCALE	MASS 0.72 ±0.04 質量はケーブルを含みます MASS W/O CABLE		NAME	RECEIVER UNIT (TABLETOP MOUNT)
DWG.No.	C4458-G01-B		REF.No.	20-0392-100G-3
				OUTLINE DRAWING

表 1 TABLE 1

寸法区分 (mm) DIMENSION	公差 (mm) TOLERANCE
L ≤ 50	±1.5
50 < L ≤ 100	±2.5
100 < L ≤ 500	±3

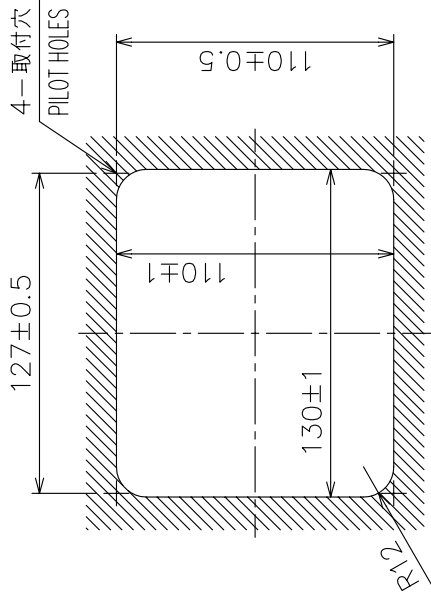
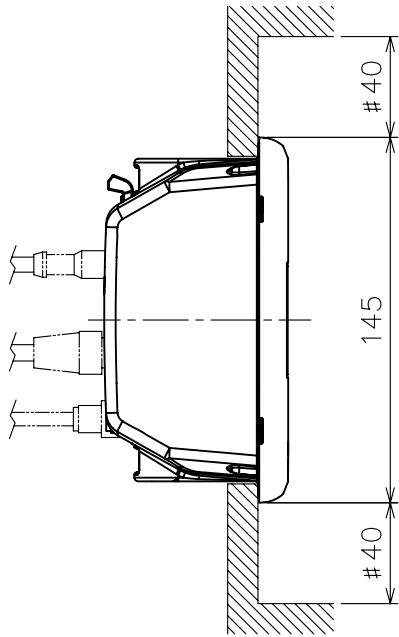

取付穴寸法図
CUTOUT DIMENSIONS

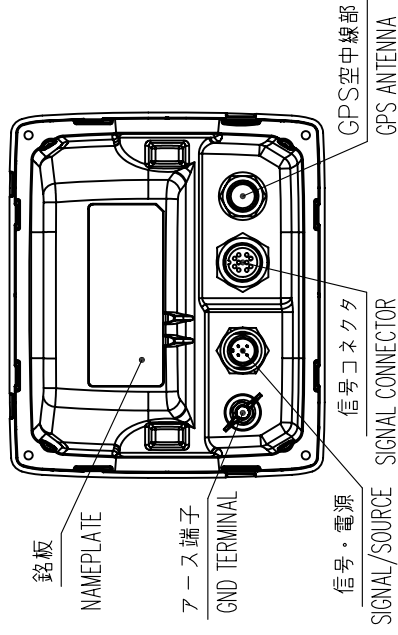
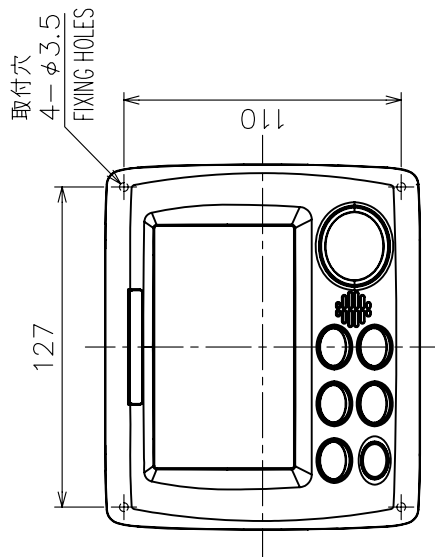
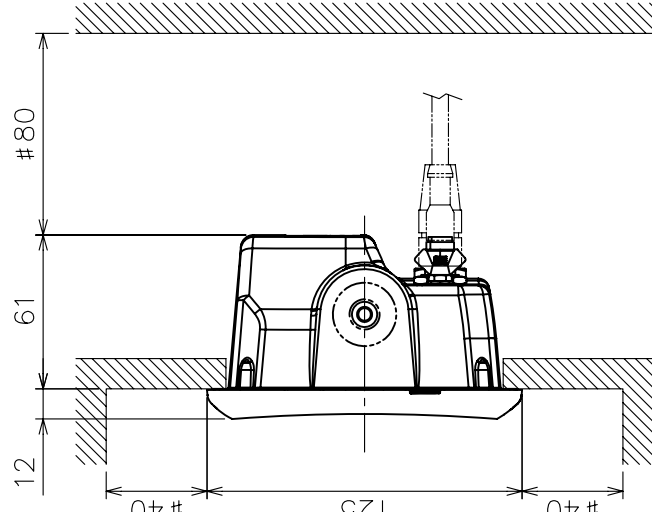

注 記

- 1) 指定外寸法公差は表 1 による。
- 2) # 印寸法は、最小サービス空間寸法とする。
- 3) 取付にはナベタツピンネジ呼び径 3×20 を使用のこと。

NOTE

1. TABLE 1 INDICATES TOLERANCE OF DIMENSIONS WHICH IS NOT SPECIFIED.
2. #: MINIMUM SERVICE CLEARANCE.
3. USE TAPPING SCREWS $\phi 3 \times 20$ FOR FIXING THE UNIT.

DRAWN	18/Oct/2010	T. YAMASAKI	TITLE	GP-33
CHECKED	19/Oct/2010	I. TAKAHASHI	名称	受信演算部 (埋込装備)
APPROVED	19/Oct/2010	Y. NISHIYAMA	外寸図	
SCALE	1/100	質量はケーブルを含みます MASS W/O CABLE	NAME	RECEIVER UNIT (FLUSH MOUNT)
DWG.No.	C4458-G02-B	REF.No.	20-0392-110G-3	OUTLINE DRAWING



表1 TABLE 1

寸法区分(mm) DIMENSION	公差(mm) TOLERANCE
L ≤ 50	±1.5
50 < L ≤ 100	±2.5
100 < L ≤ 500	±3

1-14UNS1B

ねじ山数 (25.4mmにつき) : 14
 ピッチ : 1.8143 mm
 オネジ有効長さ : 19 mm以上
 オネジ有効径 : 24.17mm

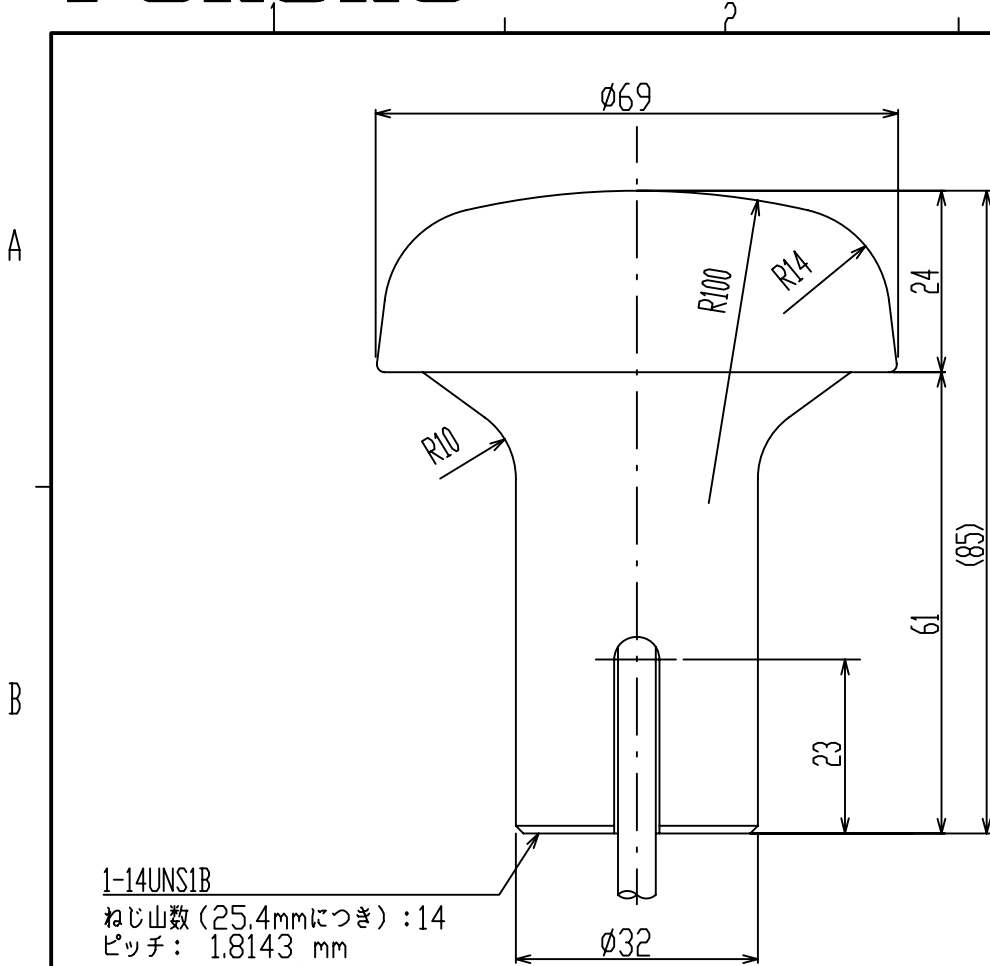
THREAD PER 25.4mm (1 INCH): 14
 PITCH: 1.8143 mm
 THREAD LENGTH: 19 mm OR MORE
 PITCH DIAMETER: 24.17mm



表2 TABLE 2

型式 TYPE	ケーブル長(m) CABLE LENGTH	プラグ PLUG	質量(kg±10%) MASS
GPA-017	10	TNC-P-3	0.6
GPA-017S	0.2	TNC-J-3	0.15

注記
 指定外の寸法公差は表1による。

NOTE
 TABLE 1 INDICATES TOLERANCE OF DIMENSIONS WHICH IS NOT SPECIFIED.

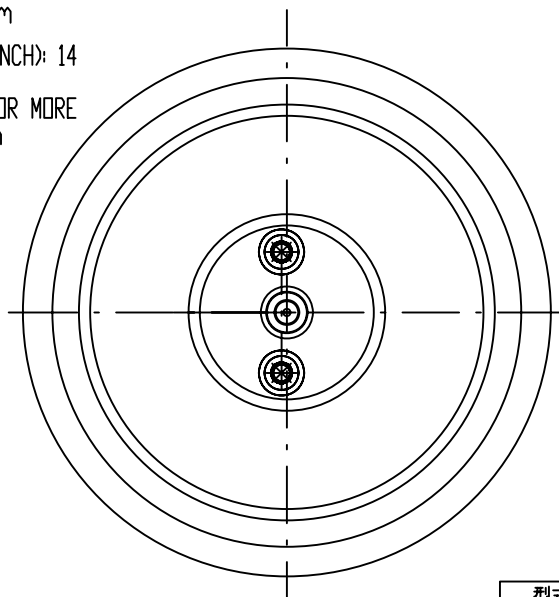
DRAWN Mar. 27 '07 T.YAMASAKI	TITLE GPA-017/017S
CHECKED Mar. 27 '07 T.TAKENO	名称 空中線部
APPROVED Mar. 27 '07 R.Esumi	外寸図
SCALE 1/1 MASS TABLE 2 表2参照	NAME ANTENNA UNIT
DWG.No. C4384-G04- L	OUTLINE DRAWING

取付位置
MOUNTING LOCATION

他の機器のアンテナから下の図の距離以上離す。
THIS FIGURE SHOWS THE SEPARATION DISTANCES FROM OTHER ANTENNAS TO AVOID MUTUAL INTERFERENCE.

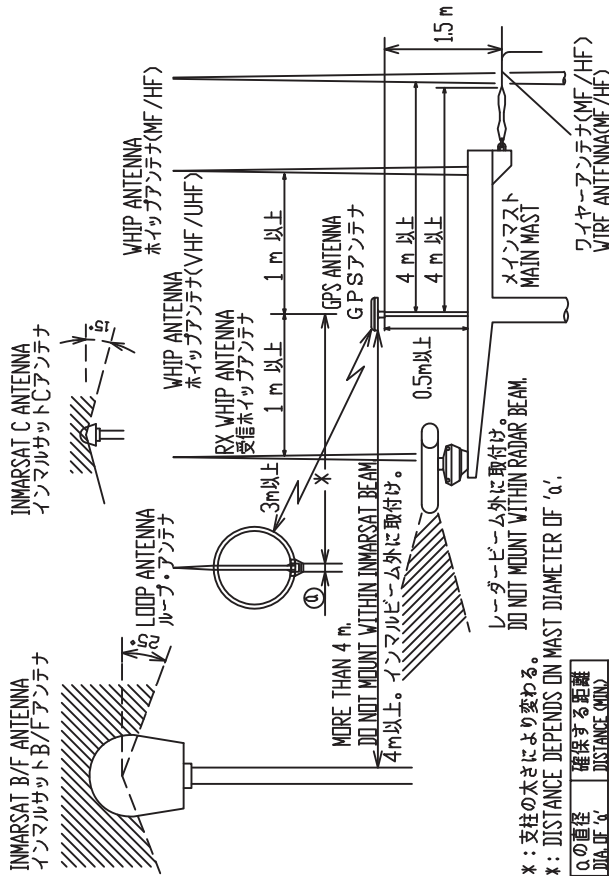

B) スタンションやパルピットにつけるとき

レール用アンテナベース No.13-RC5160
(取付可能レール直径:φ19~φ32)
(コード番号: 000-806-114)

HANDRAIL MOUNTING

USE HANDRAIL MOUNTING BASE No.13-RC5160
(CODE No.000-806-114, OPTION).
THE DIAMETER OF THE HANDRAIL MAY BE
FROM φ19mm TO φ32mm.

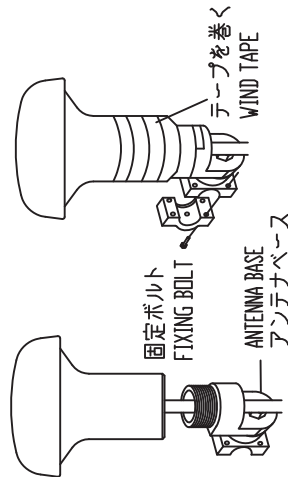

注記 1) パイプやアンテナベースはアンテナユニットにねじ込んだ後に固定する。

2) アンテナを固定するときはパイプ(アンテナベース)をアンテナにねじ込むこと。
アンテナ脚をねじるとコネクタ部やケーブルに無理がかかり、故障の原因となる。

NOTE 1. FASTEN PIPE(ANTENNA BASE) TO ANTENNA UNIT FIRST THEN FIX THEM TO MAST OR HANDRAIL.
2. WHEN FIXING ANTENNA, TURN PIPE OR ANTENNA BASE; NOT THE ANTENNA.
TURNING THE ANTENNA MAY TWIST THE CABLE AND PLACE STRESS ON CONNECTOR.

A) マストへの取付け
MAST MOUNTING

α) マスト取付金具CP20-0111(工事材料)でマストに固定する。
USE MAST MOUNTING KIT CP20-0111.

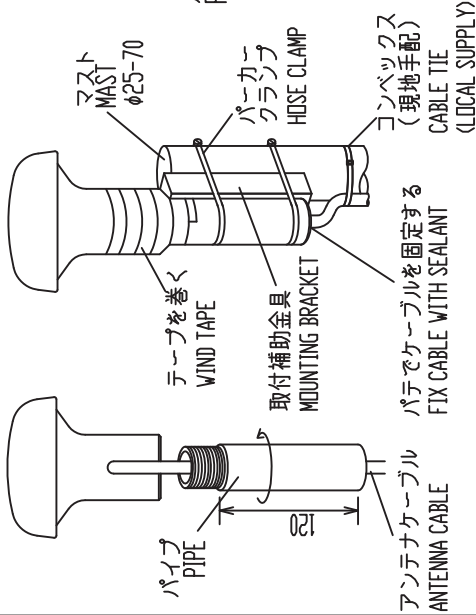

β) パイプのみを使うとき
USE A PIPE ONLY.

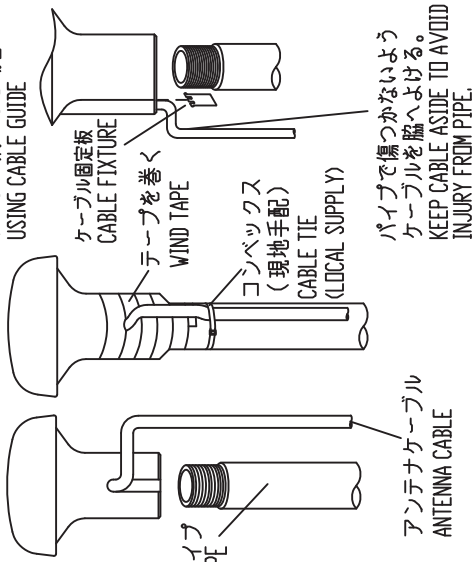

C) 取付ける場所が傾斜しているとき ANTENNA BASE MOUNTING

オプションのアンテナベースを使う。
USE OPTIONAL ANTENNA BASE.

傾斜 INCLINATION	5° - 33°	32° - 65°	65° - 98°
取付方法 MOUNTING METHOD			
アンテナ ベース型式 ANT. BASE TYPE コード番号 CODE No.	直型アンテナベース RIGHT ANGLE ANTENNA BASE No.13-QA330 000-803-239	L型アンテナベース L-TYPE ANTENNA BASE No.13-QA310 000-803-240	

アンテナベース基部
MOUNTING DIMENSIONS OF ANTENNA BASE.

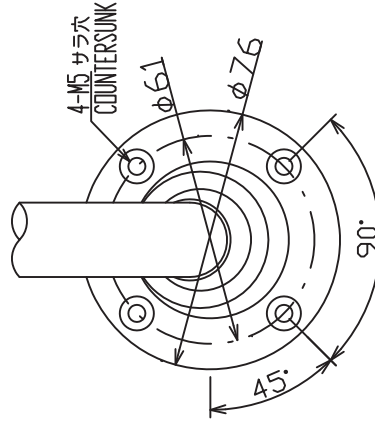

DRAWN	14/MAY/2014	T. YAMASAKI	TITLE	GPA series
CHECKED	14/MAY/2014	H. MAKI	名称	空中線部
APPROVED	15/May/2014	H. MAKI	装備要領図	ANTENNA UNIT
SCALE	MASS		NAME	ANTENNA UNIT
Doc.No.	C4384-Y01-F		INSTALLATION PROCEDURE	

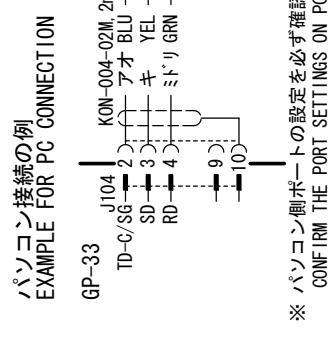
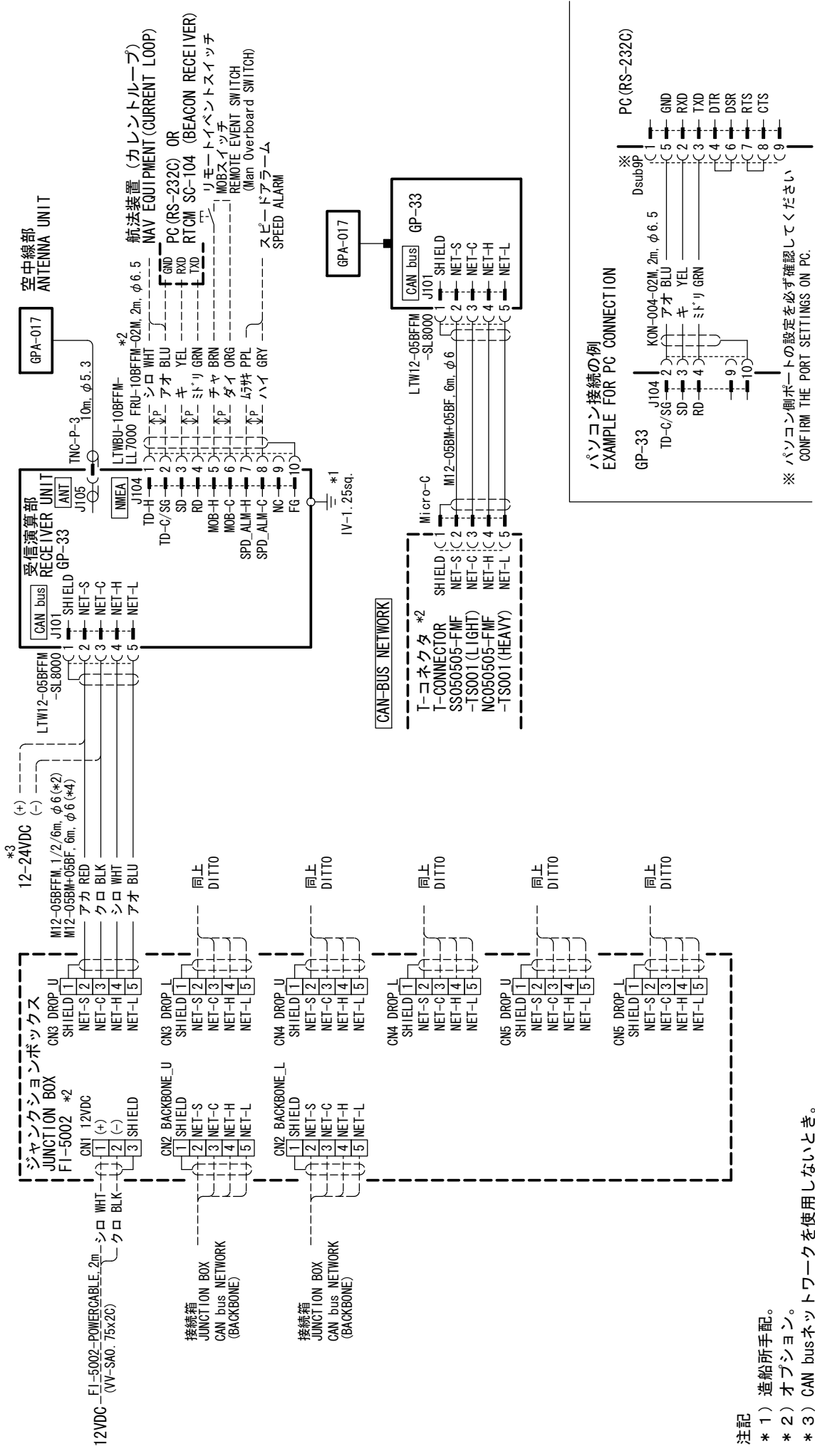

- 注記**
- * 1) 造船所手配。
 - * 2) オプション。
 - * 3) CAN bus ネットワークを使用しないとき。
 - * 4) コネクタプラグを切断して接続のこと。
- NOTE**
- * 1: SHIPYARD SUPPLY.
 - * 2: OPTION.
 - * 3: WHEN CAN bus NETWORK IS NOT USED.
 - * 4: CONNECT WIRES AFTER CONNECTOR PLUG REMOVED.

DRAWN	17/Jan/2013	T. YAMASAKI	TITLE	GP-33
CHECKED	17/Jan/2013	H. MAKI	名称	GPS航法装置
APPROVED	18/Jan/2013	Y. NI SHI YAMA	相互結線図	
SCALE	MASS	kg	NAME	GPS NAVIGATOR
DWG. No.	C4458-001-G	REF. No.	20-032-5001-1	INTERCONNECTION DIAGRAM

INDEX

A

- Alarm icon 6-1
- Alarm message 6-1
- alphanumeric data 1-9
- Anchor watch alarm 6-4
- Arrival alarm 6-4

B

- buzzer 6-2
- Buzzer type 6-2

C

- CAN bus 9-5, 9-8, 9-9
- Centering own boat's position 2-2
- COG Line 7-1
- COG/BRG ref. 7-1
- Comment 3-2
- Correction Data Set 7-4
- Cursorpad 1-1

D

- Date Display 7-7
- Datum 7-2
- Daylight Saving Time 7-7
- DECCA 7-6
- Delete a waypoint from a route 4-3
- Demo 7-7
- DGPS station 7-4
- diagnostic test 8-3
- Disable SV (satellite) 7-3
- DISP key 1-1
- Display 7-5
- DOP 1-2
- Downloading data from PC 7-13

E

- Edit waypoints on the plotter display 3-5
- Edit waypoints through the list 3-5
- End of sentence 7-13
- ENT key 1-1
- Enter a waypoint at own boat position 3-1
- Enter a waypoint through the list 3-1
- Enter a waypoint with the cursor 3-1
- Enter waypoints automatically 3-3
- Erase a route through the route list 4-5
- Erase a waypoint on the plotter display 3-7
- Erase a waypoint
through the waypoint list 3-7
- Erase all routes 4-5
- Erase all waypoints 3-8

G

- GO TO key 1-1
- Graphic 7-8
- Great circle 7-2

H

- Hard cover 1-2
- Highway Display 1-5

I

- Insert a waypoint in a route 4-4

J

- junction box 9-6

K

- Key Beep 7-6

L

- Lat Offset 7-3
- LCD brilliance 1-3
- Life of LCD 8-1
- Lon Offset 7-3
- Loran C 7-5

M

- Magnetic Variation 7-1
- MENU/ZOOM key 1-1
- MOB mark 1-9
- Mode 7-4

N

- Nav Data Display 1-6
- Navigation 7-2
- NMEA 9-10, 9-11

O

- Odometer alarm 6-5

P

- Panel brilliance 1-3
- Plotter Display 1-4

R

- Replace a waypoint in a route 4-3
- Reset (Trip) 7-7
- Rhumb line 7-2
- Route comment data format 7-13
- Route data format 7-12

S

- Satellite Monitor Display 1-7
- Set destination by cursor position 5-1
- Set destination by waypoint 5-2
- Set route as destination 5-2
- Smooth Position 7-3
- Smooth S/C (speed/course) 7-3
- Speed alarm 6-5
- Speed Based Output 6-5
- Speedometer 7-10
- Steering Display 1-6
- SV ELV (satellite elevator) 7-3

INDEX

T

Temporarily deselect a waypoint in a route	4-4
Terminator.....	9-7
Time alarm	6-5
Time Display	7-7
Time Offset	7-7
Track Color	2-4
Track Memory Used.....	2-3
Trip alarm.....	6-5
TTG/ETA SPD	7-2

U

Units.....	7-6
Uploading data to a PC.....	7-13
User Display.....	1-7

W

WAAS Search	7-4
WAAS/DGPS alarm	6-5
Waypoint data format.....	7-12
Waypoint Name	3-4
WPT/MOB key	1-1

X

XTE (Cross Track Error) alarm	6-5
-------------------------------------	-----

FURUNO Worldwide Warranty for Pleasure Boats (Except North America)

This warranty is valid for products manufactured by Furuno Electric Co. (hereafter FURUNO) and installed on a pleasure boat. Any web based purchases that are imported into other countries by anyone other than a FURUNO certified dealer may not comply with local standards. FURUNO strongly recommends against importing these products from international websites as the imported product may not work correctly and may interfere with other electronic devices. The imported product may also be in breach of the local laws and mandated technical requirements. Products imported into other countries as described previously shall not be eligible for local warranty service.

For products purchased outside of your country please contact the national distributor of Furuno products in the country where purchased.

This warranty is in addition to the customer's statutory legal rights.

1. Terms and Conditions of Warranty

FURUNO guarantees that each new FURUNO product is the result of quality materials and workmanship. The warranty is valid for a period of 2 years (24 months) from the date of the invoice, or the date of commissioning of the product by the installing certified dealer.

2. FURUNO Standard Warranty

The FURUNO standard warranty covers spare parts and labour costs associated with a warranty claim, provided that the product is returned to a FURUNO national distributor by prepaid carrier.

The FURUNO standard warranty includes:

- Repair at a FURUNO national distributor
- All spare parts for the repair
- Cost for economical shipment to customer

3. FURUNO Onboard Warranty

If the product was installed/commissioned and registered by a certified FURUNO dealer, the customer has the right to the onboard warranty.

The FURUNO onboard warranty includes

- Free shipping of the necessary parts
- Labour: Normal working hours only
- Travel time: Up to a maximum of two (2) hours
- Travel distance: Up to a maximum of one hundred and sixty (160) KM by car for the complete journey

4. Warranty Registration

For the Standard Warranty - presentation of product with serial number (8 digits serial number, 1234-5678) is sufficient. Otherwise, the invoice with serial number, name and stamp of the dealer and date of purchase is shown.

For the Onboard Warranty your FURUNO certified dealer will take care of all registrations.

5. Warranty Claims

For the Standard Warranty - simply send the defective product together with the invoice to a FURUNO national distributor. For the Onboard Warranty – contact a FURUNO national distributor or a certified dealer. Give the product's serial number and describe the problem as accurately as possible.

Warranty repairs carried out by companies/persons other than a FURUNO national distributor or a certified dealer is not covered by this warranty.

6. Warranty Limitations

When a claim is made, FURUNO has a right to choose whether to repair the product or replace it.

The FURUNO warranty is only valid if the product was correctly installed and used. Therefore, it is necessary for the customer to comply with the instructions in the handbook. Problems which result from not complying with the instruction manual are not covered by the warranty.

FURUNO is not liable for any damage caused to the vessel by using a FURUNO product.

The following are excluded from this warranty:

- a. Second-hand product
- b. Underwater unit such as transducer and hull unit
- c. Routine maintenance, alignment and calibration services.
- d. Replacement of consumable parts such as fuses, lamps, recording papers, drive belts, cables, protective covers and batteries.
- e. Magnetron and MIC with more than 1000 transmitting hours or older than 12 months, whichever comes first.
- f. Costs associated with the replacement of a transducer (e.g. Crane, docking or diver etc.).
- g. Sea trial, test and evaluation or other demonstrations.
- h. Products repaired or altered by anyone other than the FURUNO national distributor or an authorized dealer.
- i. Products on which the serial number is altered, defaced or removed.
- j. Problems resulting from an accident, negligence, misuse, improper installation, vandalism or water penetration.
- k. Damage resulting from a force majeure or other natural catastrophe or calamity.
- l. Damage from shipping or transit.
- m. Software updates, except when deemed necessary and warrantable by FURUNO.
- n. Overtime, extra labour outside of normal hours such as weekend/holiday, and travel costs above the 160 KM allowance
- o. Operator familiarization and orientation.

FURUNO Electric Company, March 1, 2011

FURUNO Warranty for North America

FURUNO U.S.A., Limited Warranty provides a twenty-four (24) months LABOR and twenty-four (24) months PARTS warranty on products from the date of installation or purchase by the original owner. Products or components that are represented as being waterproof are guaranteed to be waterproof only for, and within the limits, of the warranty period stated above. The warranty start date may not exceed eighteen (18) months from the original date of purchase by dealer from Furuno USA and applies to new equipment installed and operated in accordance with Furuno USA's published instructions.

Magnetrons and Microwave devices will be warranted for a period of 12 months from date of original equipment installation.

Furuno U.S.A., Inc. warrants each new product to be of sound material and workmanship and through its authorized dealer will exchange any parts proven to be defective in material or workmanship under normal use at no charge for a period of 24 months from the date of installation or purchase.

Furuno U.S.A., Inc., through an authorized Furuno dealer will provide labor at no cost to replace defective parts, exclusive of routine maintenance or normal adjustments, for a period of 24 months from installation date provided the work is done by Furuno U.S.A., Inc. or an AUTHORIZED Furuno dealer during normal shop hours and within a radius of 50 miles of the shop location.

A suitable proof of purchase showing date of purchase, or installation certification must be available to Furuno U.S.A., Inc., or its authorized dealer at the time of request for warranty service.

This warranty is valid for installation of products manufactured by Furuno Electric Co. (hereafter FURUNO). Any purchases from brick and mortar or web-based resellers that are imported into other countries by anyone other than a FURUNO certified dealer, agent or subsidiary may not comply with local standards. FURUNO strongly recommends against importing these products from international websites or other resellers, as the imported product may not work correctly and may interfere with other electronic devices. The imported product may also be in breach of the local laws and mandated technical requirements. Products imported into other countries, as described previously, shall not be eligible for local warranty service.

For products purchased outside of your country please contact the national distributor of Furuno products in the country where purchased.

WARRANTY REGISTRATION AND INFORMATION

To register your product for warranty, as well as see the complete warranty guidelines and limitations, please visit www.furunousa.com and click on "Support". In order to expedite repairs, warranty service on Furuno equipment is provided through its authorized dealer network. If this is not possible or practical, please contact Furuno U.S.A., Inc. to arrange warranty service.

FURUNO U.S.A., INC.
Attention: Service Coordinator
4400 N.W. Pacific Rim Boulevard
Camas, WA 98607-9408
Telephone: (360) 834-9300
FAX: (360) 834-9400

Furuno U.S.A., Inc. is proud to supply you with the highest quality in Marine Electronics. We know you had several choices when making your selection of equipment, and from everyone at Furuno we thank you. Furuno takes great pride in customer service.

Declaration of Conformity



We **FURUNO ELECTRIC CO., LTD.**

(Manufacturer)

9-52 Ashihara-Cho, Nishinomiya City, 662-8580, Hyogo, Japan

(Address)

declare under our sole responsibility that the product

GPS NAVIGATOR GP-33

(Model name, type number)

is in conformity with the essential requirements as described in the Directive 1999/5/EC of the European Parliament and of the Council of 9 March 1999 on radio equipment and telecommunications terminal equipment (R&TTE Directive) and satisfies all the technical regulations applicable to the product within this Directive

EN 300 440-1 V1.5.1: 2009 Spurious related items
IEC 60945 Ed.4.0: 2002 EMC related items
IEC 60950-1 Ed.2.0: 2005 Safety related items
IEC 60950-1 Ed.2.0 A1: 2009 Safety related items

(title and/or number and date of issue of the standard(s) or other normative document(s))

For assessment, see

- Statement of Opinion No: 10214092 issued by Telefication, The Netherlands.

On behalf of Furuno Electric Co., Ltd.

Takahiko Kusuda
Manager, QMS Secretariat
Quality Assurance Department

Nishinomiya City, Japan
January 27, 2011

(Place and date of issue)

(name and signature or equivalent marking of authorized person)