



4PLS

Frequency Hopping Spread Spectrum



Telemetry System



4PLS

Frequency Hopping Spread Spectrum



Digital Proportional
R/C System
for Use with Surface Models

INSTRUCTION MANUAL

Futaba

1M23N28302

Futaba

Digital Proportional R/C System



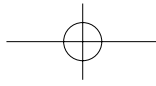

Thank you for purchasing a Futaba 4PLS-2.4GHz system.
Before using your 4PLS-2.4GHz system, read this manual carefully in order to use
your R/C set safely.

After reading this manual, store it in a safe place.

IN NORTH AMERICA

Please feel free to contact the Futaba Service Center for assistance in operation, use and programming. Please be sure to regularly visit the 4PLS Frequently Asked Questions web site at www.futaba-rc.com/faq/. This page includes extensive programming, use, set up and safety information on the 4PLS radio system and is updated regularly. Any technical updates and US manual corrections will be available on this web page. If you do not find the answers to your questions there, please see the end of our F.A.Q. area for information on contacting us via email for the most rapid and convenient response.

Don't have Internet access? Internet access is available at no charge at most public libraries, schools, and other public resources. We find internet support to be a fabulous reference for many modelers as items can be printed and saved for future reference, and can be accessed at any hour of the day, night, weekend or holiday. If you do not wish to access the internet for information, however, don't worry. Our support teams are available Monday through Friday 8-5 Central time to assist you.

FOR SERVICE ONLY:

Futaba Service Center
3002 N. Apollo Drive, Suite 1
Champaign, IL 61822
Phone: 217-398-0007
www.futaba-rc.com/service.html
Email: service@futaba-rc.com

FOR SUPPORT :

(PROGRAMMING AND USER QUESTIONS)
Please start here for answers to most questions:
www.futaba-rc.com/faq/
Fax: 217-398-7721
Phone: 217-398-8970 option 2
E-mail: support@futaba-rc.com

OUTSIDE NORTH AMERICA

Please contact your Futaba importer in your region of the world to assist you with any questions, problems or service needs.

Please recognize that all information in this manual, and all support availability, is based upon the systems sold in North America only. Products purchased elsewhere may vary. Always contact your region's support center for assistance.

Application, Export, and Modification

1. This product may be used for models only. It is not intended for use in any application other than the control of models for hobby and recreational purposes.

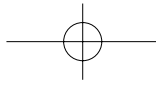

2. Exportation precautions:

(a) When this product is exported from the country of manufacture, its use is to be approved by the laws governing the country of destination for devices that emit radio frequencies. If this product is then re-exported to other countries, it may be subject to restrictions on such export. Prior approval of the appropriate government authorities may be required. If you have purchased this product from an exporter outside your country, and not the authorized Futaba distributor in your country, please contact the seller immediately to determine if such export regulations have been met.

(b) Use of this product with other than models may be restricted by Export and Trade Control Regulations, and an application for export approval must be submitted.

3. Modification, adjustment, and replacement of parts: Futaba is not responsible for unauthorized modification, adjustment, and replacement of parts on this product. Any such changes may void the warranty.

Battery Recycling (for U.S.A.)



The RBRC™ SEAL on the (easily removable) nickel-cadmium battery and nickel-metal-hydrate battery contained in Futaba products indicates that Futaba Corporation of America is voluntarily participating in an industry program to collect and recycle these batteries at the end of their useful lives, when taken out of service within the United States. The RBRC™ program provides a convenient alternative to placing used nickel-cadmium batteries and nickel-metal-hydrate batteries into the trash or municipal waste system, which is illegal in some areas.

You may contact your local recycling center for information on where to return the spent battery. Please call 1-800-8-BATTERY for information on NiCd/NiMH battery recycling in your area. Futaba Corporation of America's involvement in this program is part of its commitment to protecting our environment and conserving natural resources.

NOTE: Our instruction manuals encourage our customers to return spent batteries to a local recycling center in order to keep a healthy environment.

RBRC™ is a trademark of the Rechargeable Battery Recycling Corporation.

-
- No part of this manual may be reproduced in any form without prior permission.
 - The contents of this manual are subject to change without prior notice.
 - This manual has been carefully written. Please write to Futaba if you feel that any corrections or clarifications should be made.
 - Futaba is not responsible for the use of this product.

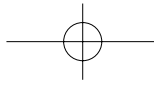

Table Of Contents

For Your Safety As Well As That Of Others.....8

Explanation Of Symbols	8
2.4GHz System Precautions	8
Receiver Mode Precautions	8
Operation Precautions	9
Ni-MH/Ni-Cd Battery Handling Precautions	10
Storage And Disposal Precautions	11
Other Precautions	11

Before Using12

Features	12
Set Contents	14
TransmitterT4PLS.....	15
Nomenclature.....	15
Battery Replacement Method.....	16
When Using The Optional Battery.....	17
When Exchanging For The Optional Battery	17
Low Battery Alarm.....	18
Power & Display Switch.....	19
Display When Power Switch Is Turned On	20
LCD Screen Contrast	20
Power Off Forgotten Alarm.....	20
Digital Trim Operation.....	21
Grip Lever Operation.....	21
Mechanical ATL Adjustment.....	22
Wheel & Trigger Tension Adjustment.....	22
Trigger Slide Adjustment	23
About Transmitter Antenna And Receiver.....	23
About The Transmitter Antenna	23
Receiver Terminology.....	24
Receiver Installation.....	24

Installation25

Receiver And Servo Connections	25
Installation Safety Precautions	26

Initial Set-Up29

Preparations (Transmitter).....	29
Receiver Type Check (RX MODE)	29

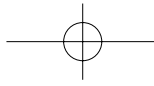

Receiver Type Change & How To Link	30
Throttle Mode Check.....	33
Trims Initial Set-Up	33

Function Map35

Operation Of Screen	35
Calling The Menu Screen.....	35
Selecting Items On The Menu Screen	36
Value Of Each Function And Changing The Set Value	36
Basic Menu Japanese Katakana Character Display	37
Function List.....	38

Functions39

Model "MODEL"	39
Model Menu Display.....	39
Model Selection "SELECT"	40
Model memory call	
Model Copy "COPY"	41
Model memory copy	
Model Reset "RESET"	42
Model memory reset	
Model Name "MDL NAME"	43
Model memory name & User name, set/modify	
Servo Reverse "REVERSE"	44
Servo operation reversing	
Subtrim "SUBTRIM"	45
Servo center position fine adjustment	
End Point Adjuster "END POINT"	46
End point adjustment	
Fail Safe Function "FAIL SAFE"	49
Fail safe, battery fail safe function	
Exponential Adjustment "EXP".....	51
Steering operation curve / Throttle curve adjustment	
Servo Speed "SPEED"	54
Steering/ Throttle servo delay adjustment	
Throttle Acceleration "TH ACCEL"	57
Function which adjusts the movement characteristic from the throttle neutral position	
A.B.S. Function "TH A.B.S"	59
Pulse brake	
Channel 3/4 "CH3/CH4"	63
Channel 3/4 Position	
Steering Dual Rate/ Throttle ATL "D/R ATL "	64
Steering D/R, Throttle ATL Rate	

**For Your Safety
As Well As
That Of Others**

**Before
Using**

Installation

**Initial
Set-Up**

**Function
Map**

Functions

Reference

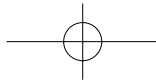

Select Switch Dial Function "SW/ DIAL"	65
Selection of functions operated by dial, digital trim and switch	
Brake Mixing "BRAKE MIX"	68
Front and rear independent brake control for 1/5GP car, etc.	
Programmable Mixing "PROG MIX"	70
Programmable mixing between arbitrary channels	
4WS Mixing "4WS"	72
Special mixing used with Crawler and other 4WS type vehicles	
Dual ESC Mixing "DUAL ESC"	74
Special mixing used with Crawler and other 4WD type vehicles	
Gyro Mixing "GYRO MIX"	76
Can be setting the Futaba car rate gyro.	
CPS Mixing "CPS MIX"	78
Controls the Futaba CPS-1 channel power switch.	
Throttle Mode "TH MODE"	80
Throttle Servo Neutral Position "SXNT"	80
Throttle servo forward and brake operation proportion setting	
Idle-Up "IDLUP"	81
Idle up at engine start	
Neutral Brake "NTBRK"	82
Neutral brake function	
Throttle Off (Engine Cut) "THOFF"	83
Engine cut off by switch	
ESC Link Function "MC LINK"	84
Special function, Futaba ESC (MC940CR, MC960CR, MC950CR, MC851C, MC602C, MC402CR, etc.)	
Data Transfer "MDL TRANS"	92
The T4PLS model memory data to another T4PLS	
Timer Function "TIMER"	94
Up, Fuel down, or lap timer	
Lap List "LAP LIST"	100
Lap timer data check	
System Functions "SYSTEM"	101
Liquid crystal screen contrast adjustment	
Liquid crystal screen backlighting display mode setup	
Backlight display time setup	
Backlight brightness setup	
Battery type setting	
Buzzer sound tone adjustment	
The power off forgotten alarm setting	
Item which displays the basic menu screen in katakana characters for Japanese use	
HOME screen display mode setting	

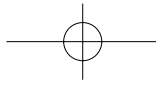

Adjuster "ADJUSTER"	105
Steering wheel and throttle trigger correction	
Telemetry "TELEMETRY"	107
Telemetry/ Log Screen Map	108
Telemetry Function ON/OFF	109
Telemetry Sensor Setting	110
Log Setting, Start/ Stop	112
Log Data List	114
Reference	115
Ratings	115
Warning Displays	116
Optional Parts	118
When requesting repair	118

**For Your Safety
As Well As
That Of Others**

**Before
Using**

Installation

**Initial
Set-Up**

**Function
Map**

Functions

Reference

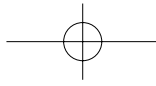

For Your Safety As Well As That Of Others

Use this product in a safe manner. Please observe the following safety precautions at all times.

Explanation Of Symbols

The parts of this manual indicated by the following symbols are extremely important and must be observed.

Symbols	Explanation
Danger	Indicates a procedure which could lead to a dangerous situation and may cause death or serious injury if ignored and not performed properly.
Warning	Indicates procedures which may lead to dangerous situations and could cause death or serious injury as well as superficial injury and physical damage.
Caution	Indicates procedures that may not cause serious injury, but could lead to physical damage.

Symbols:

: Prohibited

: Mandatory

2.4GHz System Precautions

Warning

- Special attention should be paid before turning on the system while other cars are running or other airplanes are flying because the 2.4GHz RC system could potentially affect them.
- Be sure to set the Fail Safe function.

Receiver Mode Precautions

Caution

- When using the T4PLS in the T-FHSS (HIGH) and S-FHSS (HIGH) mode, always use it under the following conditions:

Servos :Futaba digital servo (including BLS Series brushless servos)

Receiver's battery :Matched to the ratings of the receiver and connected digital servo (dry cell battery cannot be used).

Transmitter mode :RX MODE (See p.29 for setting method.)

Under other conditions, the set will not operate, or the specified performance will not be displayed even if it operates. In addition, it may cause servo trouble. Futaba will not be responsible for damage, etc. caused by combination with the products of other companies.

In addition, the FSU Fail Safe Unit cannot be used because the system is different. Use the fail safe function of the transmitter.

- When using analog servos, always switch the T4PLS servo response to the "NORM" mode.
Transmitter mode:"T-FHSS(NORM)", "T-FHSS(NORM)"and FHSS mode (See p.29 for setting method.)
Receiver's battery :Matched to the ratings of the receiver and connected servo (dry cell battery cannot be used).

The set cannot operate in the "HIGH" mode. Operation in this mode will cause trouble with the servo and other equipment.

Digital servos (including BLS Series brushless servos) can also be used in the "NORM" mode.

For Your Safety As Well As That Of Others

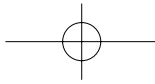

Operation Precautions

Warning

- ⊘ Do not operate outdoors on rainy days, run through puddles of water or use when visibility is limited.

Should any type of moisture (water or snow) enter any component of the system, erratic operation and loss of control may occur.

- ⊘ Do not operate in the following places.
 - Near other sites where other radio control activity may occur.
 - Near people or roads.
 - On any pond when passenger boats are present.
 - Near high tension power lines or communication broadcasting antennas.

Interference could cause loss of control. Improper installation of your Radio Control System in your model could result in serious injury.

- ⊘ Do not operate this R/C system when you are tired, not feeling well or under the influence of alcohol or drugs.

Your judgment is impaired and could result in a dangerous situation that may cause serious injury to yourself as well as others.

- ⊘ Do not touch the engine, motor, speed control or any part of the model that will generate heat while the model is operating or immediately after its use.

These parts may be very hot and can cause serious burns.

- ❗ Always perform an operating range check prior to use.

Problems with the radio control system as well as improper installation in a model could cause loss of control. (Simple range test method)

Have a friend hold the model, or clamp it down or place it where the wheels or prop cannot come in contact with any object. Walk away and check to see if the servos follow the movement of the controls on the transmitter. Should you notice any abnormal operation, do not operate the model. Also check to be sure the model memory matches the model in use.

- ❗ Turning on the power switches.

Always check the throttle trigger on the transmitter to be sure it is at the neutral position.

1. Turn on the transmitter power switch.
2. Turn on the receiver or speed control power switch.

Turning off the power switches

Always be sure the engine is not running or the motor is stopped.

1. Turn off the receiver or speed control power switch.
2. Then turn off the transmitter power switch.

If the power switches are turned off in the opposite order, the model may unexpectedly run out of control and cause a very dangerous situation.

- ❗ When making adjustments to the model, do so with the engine not running or the motor disconnected.

You may unexpectedly lose control and create a dangerous situation.

- ❗ Before running (cruising), check the fail safe function.

Check Method; Before starting the engine, check the fail safe function as follows:

- 1) Turn on the transmitter and receiver power switches.
- 2) Wait at least one minute, then turn off the transmitter power switch. (The transmitter automatically transfers the fail safe data to the receiver every minute.)
- 3) Check if the fail safe function moves the servos to the preset position when reception fails.

The fail safe function is a safety feature that minimizes set damage by moving the servos to a preset position when reception fails. However, if set to a dangerous position, it has the opposite effect. When the reverse function was used to change the operating direction of a servo, the fail safe function must be reset.

Setting example: Throttle idle or brake position

For Your Safety As Well As That Of Others

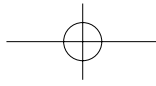

NiMH / NiCd / LiFe Battery Handling Precautions

(Only when NiMH/NiCd /LiFe batteries are used)

Warning

- ⊘ Never plug the charger into an outlet of other than the indicated voltage.
Plugging the charger into the wrong outlet could result in an explosion or fire.
- ⊘ Never insert or remove the charger while your hands are wet.
You may get an electric shock.
- ⊘ Do not use the T4PLS transmitter's battery, as the receiver's battery.
Since the transmitter's battery has an overload protection circuit, the output power will be shut down when the high current load is applied. This may result in runaway or fatal crash.
- ❗ Always check to be sure your batteries have been charged prior to operating the model.
Should the battery go dead while the model is operating, loss of control will occur and create a very dangerous situation.
- ❗ To recharge the transmitter battery, use the special charger made for this purpose.
Overcharging could cause the battery to overheat, leak or explode. This may lead to fire, burns, loss of sight and many other types of injuries.

Caution

- ⊘ Do not use commercial AA size NiCd and NiMH batteries.
Quick charging may cause the battery contacts to overheat and damage the battery holder.
- ⊘ Do not short circuit the battery terminals.
A short circuit across the battery terminals may cause abnormal heating, fire and burns.
- ⊘ Do not drop the battery or expose it to strong shocks or vibrations.
The battery may short circuit and overheat; electrolyte may leak out and cause burns or chemical damage.
- ❗ When the model is not being used, always remove or disconnect the battery.
Leaving the battery connected could create a dangerous situation if someone accidentally turns on the receiver power switch. Loss of control could occur.
- ❗ Always keep the charger disconnected from the outlet while it is not in use.

Storage And Disposal Precautions

Warning

- ⊘ Do not leave the radio system or models within the reach of small children.
A small child may accidentally operate the system. This could cause a dangerous situation and injuries. Ni-Cd batteries can be very dangerous when mishandled and cause chemical damage.
- ⊘ Do not throw NiMH/NiCd/LiFe batteries into a fire. Do not expose batteries to extreme heat. Also do not disassemble or modify a battery pack.
Overheating and breakage will cause the electrolyte to leak from the cells and cause skin burns, loss of sight, and other injuries.

For Your Safety As Well As That Of Others

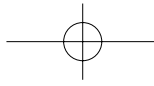

! When the system will not be used for any length of time, store the system with HiMH/Ni-Cd batteries in a discharged state. Be sure to recharge the batteries prior to the next time the system is used.

If the batteries are repeatedly recharged in a slightly discharged state, the memory effect of the Ni-MH/Ni-Cd battery may considerably reduce the capacity. A reduction in operating time will occur even when the batteries are charged for the recommended time. (After discharge to 1cell E.V.=1V)

! When the LiFe batteries will not be used for a long time, to prevent it from deteriorating we recommend that it be kept in about the half capacity state instead of fully charged. Also be careful that the battery does not enter the over-discharged state due to self-discharge.

Periodically (about every 3 months) charge the battery.

<NiMH/NiCd Battery Electrolyte>

The electrolyte in NiCd/NiMH batteries is a strong alkali. Should you get even the smallest amount of the electrolyte in your eyes, DO NOT RUB. Wash immediately with water, and seek medical attention at once. The electrolyte can cause blindness. If electrolyte comes in contact with your skin or clothes, wash with water immediately.

! Warning

! Do not store your R/C system in the following places.

- Where it is extremely hot or cold.
- Where the system will be exposed to direct sunlight.
- Where the humidity is high.
- Where vibration is prevalent.
- Where dust is prevalent.
- Where the system would be exposed to steam and condensation.

Storing your R/C system under adverse conditions could cause deformation and numerous problems with operation.

! If the system will not be used for a long period of time, remove the batteries from the transmitter and model and store in a cool, dry place.

If the batteries are left in the transmitter, electrolyte may leak and damage the transmitter. This applies to the model also. Remove the batteries from it also to prevent damage.

<NiMH/NiCd/Li-ion Battery Recycling>

A used battery is a valuable resource. Insulate the battery terminals and dispose of the battery by taking it to a battery recycling center.

For Your Safety As Well As That Of Others

Other Precautions

! Caution

! Do not expose plastic parts to fuel, motor spray, waste oil or exhaust.

The fuel, motor spray, waste oil and exhaust will penetrate and damage the plastic.

! Always use only genuine Futaba transmitters, receivers, servos, ESCs (electronic speed controls), NiMH/NiCd batteries and other optional accessories.

Futaba will not be responsible for problems caused by the use of other than genuine Futaba parts. Use the parts specified in the instruction manual and catalog.

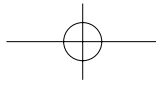

Features

-Telemetry system

The T4PLS transmitter has adopted the newly developed bidirectional communication system "T-FHSS"

-2.4GHzSS (Spread Spectrum) radio communication system

Frequency channel setting is unnecessary: Channel shifting takes place within the 2.4GHz band automatically. This system minimizes the interference from other 2.4GHz systems.

-Model memory for 40 models

Model names can use up to 10 letters, numbers, and symbols, so that logical names may be used. A model memory with different setups can be created by using the model copy function.

- Menu Selection

The setup screens are called from menu screens. The menu screen can be selected from among 2 levels (LEVEL1/LEVEL2).

-Brake mixing for large cars (BRAKE)

Brake mixing of the front and rear wheels of 1/5GP and other large cars can be adjusted independently.

-4WS mixing for crawlers and other 4WS type (4WS)

This function can be used with crawlers and other 4WS type vehicles.

-Dual ESCs mixing for crawlers cars (DUAL ESC)

ESC at the front and rear are controlled independently.

-Gyro mixing (GYRO MIX)

The sensitivity of Futaba car rate gyros can be adjusted from the T4PLS.

-CPS-1 mixing (CPS MIX)

LED lighting and flashing control using our CPS-1 channel power switch can be matched to steering and throttle operation by switch only.

-Anti-skid braking system (TH A.B.S)

This function applies the brakes so that the tires of gasoline engine cars, etc. do not lose their grip on the road even when braking at corners.

-Throttle acceleration (ACCEL)

Gasoline engine cars have a time lag before the clutch and brakes become effective. The throttle acceleration function reduces this time lag.

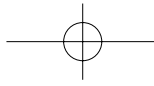

-Throttle speed (SPEED)

Sudden trigger operation on a slippery road surface will only cause the tires to spin and the model to not accelerate smoothly. By setting the throttle speed function, operation can be performed smoothly and easily. It also suppresses battery consumption.

-Steering speed (SPEED)

When you sense that the steering servo is too fast, etc., the servo operating speed (direction that suppresses the maximum speed) can be adjusted.

-Racing timer (TIMER)

The lap timer can record 100 lap times and total time. The timer can also be started automatically by trigger operation. The race time and audible alarm can be set. Re-/fueling time are indicated by an audible alarm. An up timer is also provided.

-Digital trim

The current trim position is displayed on the LCD screen. The operating amount of 1 step can also be adjusted. Trim operation has no effect on the maximum travel of the steering and throttle servos.

-Function select switch / dial function (TRIM DIAL)

This function assigns functions to 2 switches and dials (digital trim, digital dial). The step amount and operating direction can also be adjusted. Trim positioning at each model call is unnecessary because all the dials are digital.

-ESC-Link function (MC-LINK)

This is a dedicated function which allows setting of the contents of the Link software which makes possible Futaba speed controller (ESC), MC950CR, MC850C, MC851C, MC602C, MC402CR, etc. variable frequency and other data changes by T4PLS.

-Trigger position can be changed

The position of the throttle trigger can be moved forward and backward.

-Tension adjustment function

The tension of the steering wheel & throttle trigger springs can be adjusted from the outside.

-Mechanical ATL Adjustment

Make this adjustment when you want to decrease the total travel of the brake (push) side of the throttle trigger.

-Display switch

Display switch allows function setup without transmitting.

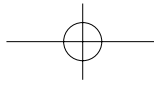

Set Contents

After opening the box, first check if the contents conform to the following. The contents depend on the set as shown below.

Transmitter	T4PLS
Receiver	R304SB
Miscellaneous	<p>Dry battery holder *Installed in transmitter.</p> <p>Receiver switch</p> <p>Mini screwdriver * It is used for R304SB.</p> <p>Instruction manual</p>

Before Using

- If any of the set contents are missing, or you have any questions, please contact your dealer.

Caution

! When using the T4PLS in the T-FHSS (HIGH) and S-FHSS (HIGH) mode, always use it under the following conditions:

Servos :Futaba digital servo (including BLS Series brushless servos)

Receiver's battery :Matched to the ratings of the receiver and connected digital servo (dry cell battery cannot be used).

Transmitter mode :RX MODE (See p.29 for setting method.)

Under other conditions, the set will not operate, or the specified performance will not be displayed even if it operates. In addition, it may cause servo trouble. Futaba will not be responsible for damage, etc. caused by combination with the products of other companies.

In addition, the FSU Fail Safe Unit cannot be used because the system is different. Use the fail safe function of the transmitter.

! When using analog servos, always switch the T4PLS servo response to the "NORM" mode.

Transmitter mode:"T-FHSS(NORM)", "T-FHSS(NORM)"and FHSS mode (See p.29 for setting method.)

Receiver's battery :Matched to the ratings of the receiver and connected servo (dry cell battery cannot be used).

The set cannot operate in the "HIGH" mode. Operation in this mode will cause trouble with the servo and other equipment.

Digital servos (including BLS Series brushless servos) can also be used in the "NORM" mode.

! Always use only genuine Futaba transmitters, receivers, servos, ESCs (electronic speed controls), NiMH, NiCd, Li-ion batteries and other optional accessories.

Futaba will not be responsible for problems caused by the use of other than Futaba genuine parts. Use the parts specified in the instruction manual and catalog.

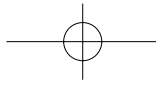

Transmitter T4PLS

Nomenclature

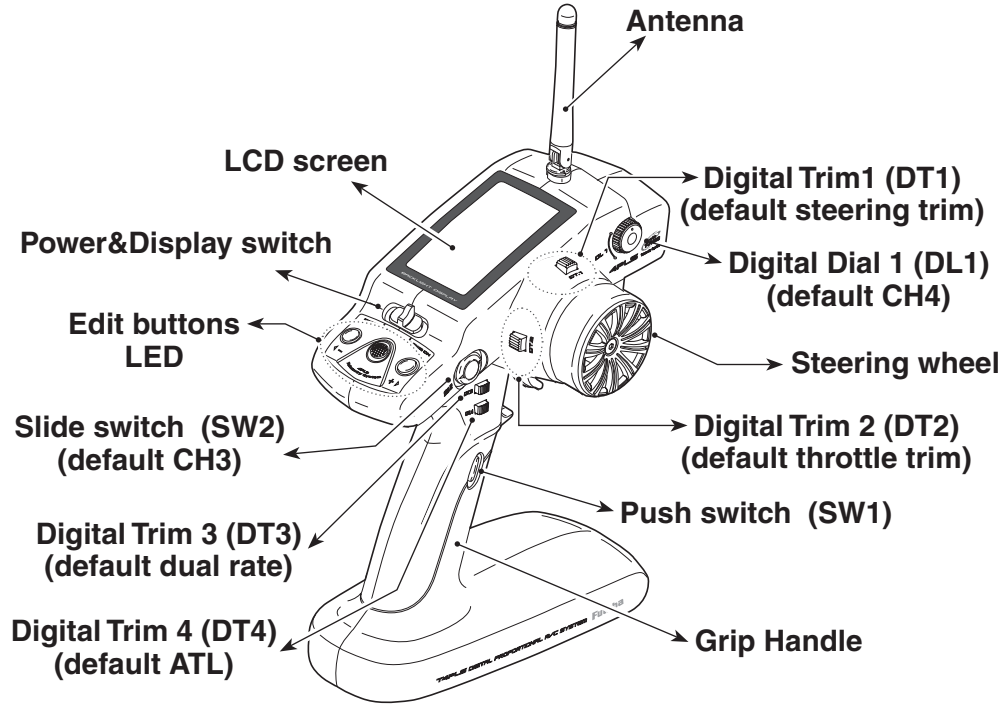

Before Using

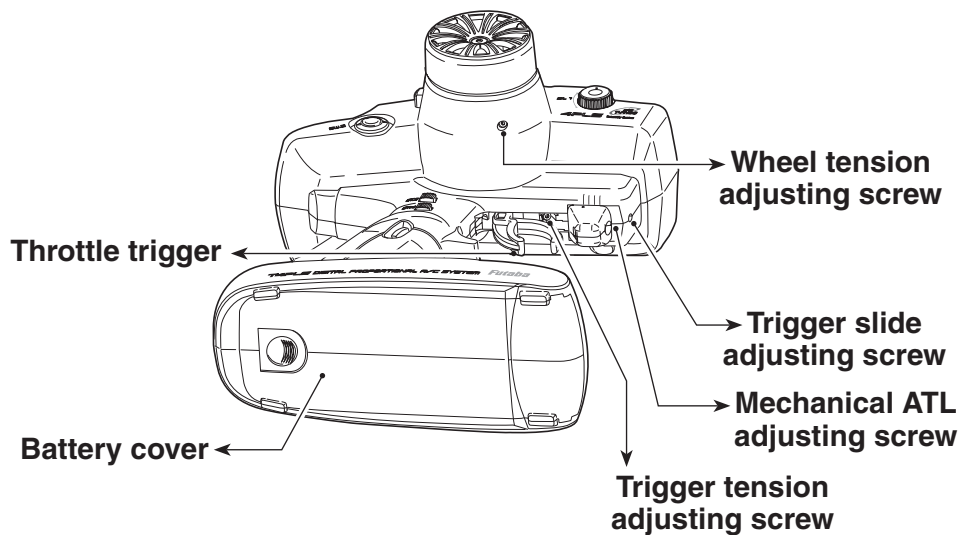

*The switches, dial, and trimmers in the figure are shown in the initial setting position.

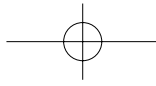

Battery Replacement Method (4 AA Size Batteries)

Load the four batteries in accordance with the polarity markings on the battery holder.

Battery Replacement Method

- 1** Remove the battery cover from the transmitter by sliding it in the direction of the arrow in the figure.
- 2** Remove the used batteries.
- 3** Load the new AA size batteries. Pay very close attention to the polarity markings and reinsert accordingly.
- 4** Slide the battery cover back onto the case.

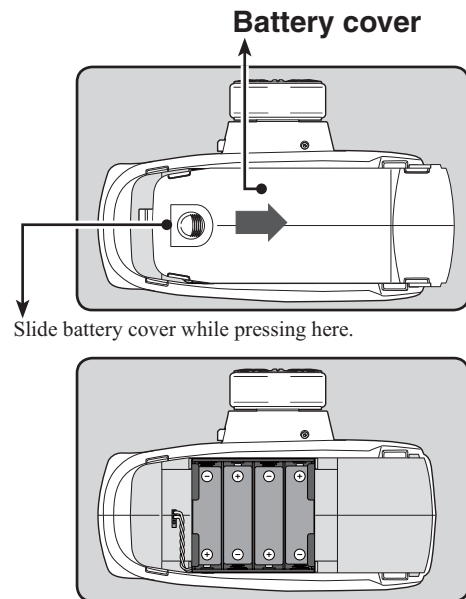

Before Using

Check:

Turn the power switch on the transmitter to the ON position. Check the battery voltage display on the LCD screen. If the voltage is low, check the batteries for insufficient contact in the case or incorrect battery polarity.

Disposal of the Dry Cell Batteries:

The method to dispose of used dry cell batteries depends on the area in which you reside. Dispose of the batteries in accordance with the regulations for your area.

Caution

- Never try to recharge a dry cell battery.**
The transmitter may be damaged or the battery electrolyte may leak or the battery may break.
- Insert the batteries in the correct polarity.**
If the polarity is incorrect, the transmitter may be damaged.
- When the transmitter is not in use, remove the batteries.**
If the battery electrolyte leaks, wipe off the case and contacts.
- Do not use commercial AA size NiCd and NiMH batteries.**
Quick charging may cause the battery contacts to overheat and damage the battery holder.

Use prohibited

AA size Ni-cd

AA size Ni-MH

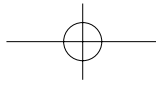

When Using The Optional Battery

When using an optional rechargeable battery, replace the battery as described below.

- Always use the optional HT5F1700B or FT2F2100B rechargeable battery.
- When the transmitter will not be used for a long time, remove the battery.

Battery Replacement Method

- 1 Refer to the previous description and remove the transmitter battery cover.
- 2 After removing the dry cell battery box from the transmitter, disconnect the connector.
- 3 Insert the connector of the new battery and load the new battery into the transmitter.
- 4 Finish by installing the battery cover.

Caution

- ⚠ When closing the battery cover, be careful that the battery cover does not pinch the battery lead wires.
Shorting of the battery lead wires may lead to fire and abnormal heating and cause burns or fire disaster.

Before Using

When Exchanging For The Optional Battery

Charge Of A NiMH Battery

(Example: When using the HT5F1800B with the special charger)

- 1 Plug the transmitter cord of the special charger into the charging jack on the rear of the transmitter.
- 2 Plug the charger into an AC outlet.
- 3 Check that the charging LED lights.

The charging time when charging the HT5F1800B battery with the optional special charger is approximately 15 hours. However, when the battery has not been used for some time, repeat charging 2 or 3 times to activate the battery.

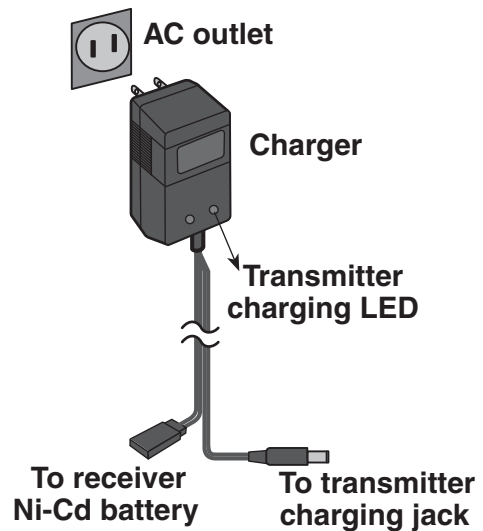

When using Futaba CR-2000

The HT5F1700B/1800B is 5-cells, so, when charging the HT5F1700B battery with Futaba CR-2000 charger, you have to use the RX output side.

Over current protection

The transmitter charging circuit is equipped with an over current protection circuit (1.0A). If the battery is charged with a quick charger for other than digital proportional R/C sets, it may not be fully charged.

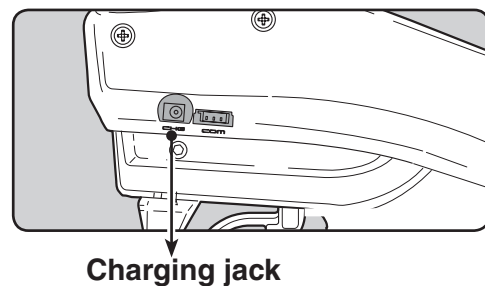

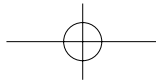

Charge Of A LiFe Battery

(Example: When using the FT2F1700B/2100B with the special charger)

- 1** A LiFe battery is removed from T4PLS.
- 2** 2P connector is removed from T4PLS.
- 3** Balance charge is carried out from the charger only for LiFe.

Charge the optional FT2F1700B/2100B (LiFe) battery with the special charger in accordance with the instruction manual supplied.

When the battery will not be used for a long time, to prevent it from deteriorating we recommend that it be kept in about the half capacity state instead of fully charged. Also be careful that the battery does not enter the over-discharged state due to self-discharge.
Periodically (about every 3 months) charge the battery.

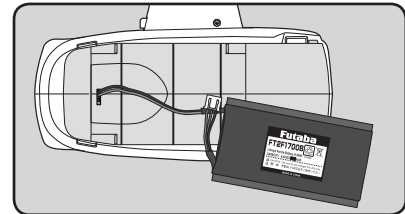
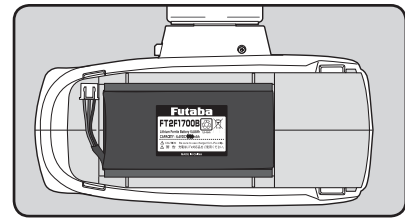

Before Using

⚠ Warning

- ⊘ Never plug it into an outlet of other than the indicated voltage.
Plugging the charger into the wrong outlet could result in an explosion or fire.
- ⊘ Do not insert and remove the charger when your hands are wet.
It may cause an electric shock.
- ⓘ Always use the special charger or a quick charger for digital proportional R/C sets to charge a digital proportional R/C set Ni-MH battery.
Overcharging a Ni-MH battery can result in burns, fire, injuries, or loss of sight due to overheating, breakage, or electrolyte leakage.

⚠ Caution

- ⓘ When the charger is not in use, disconnect it from the AC outlet.
Do this to prevent accidents and to avoid overheating.

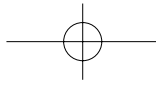

Low Battery Alarm

If the transmitter battery voltage drops below the usable range, an audible alarm will sound and "BATTERY LOW VOLTAGE" will be displayed on the LCD screen. If the battery goes dead while running (cruising), you will lose control of the vehicle (boat). Therefore, retrieve the vehicle (boat) immediately and cease operation.

Because the low battery alarm voltage of a dry cell battery is different from that of a rechargeable battery pack (genuine Futaba option), the type of power source used must be set by system setting (P101).

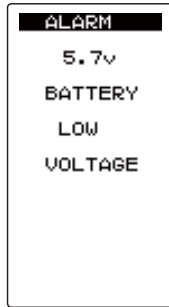

Warning

❗ When a low battery alarm is generated, cease operation immediately and retrieve the model.

If the battery goes dead while in operation, you will lose control of the model.

Before Using

Power & Display Switch

The power switch and display switch of the T4PLS are integrated. In the PWR ON mode, radio waves are transmitted and in the DISP mode, model data, settings can be checked without transmitting radio waves.

In addition, some setting menus may only be displayed in the DISP mode.

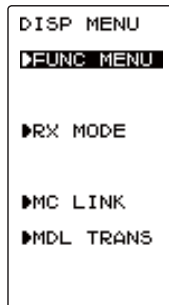

DISP

Radio waves are not being transmitted

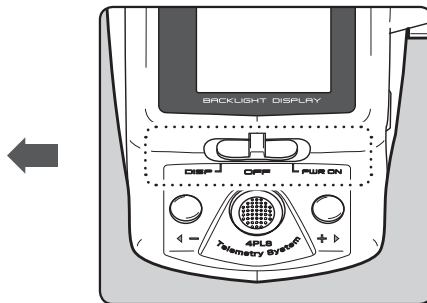

OFF

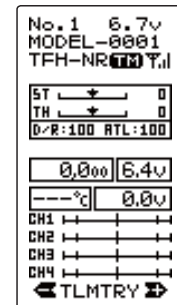

PWR ON

Radio waves are being transmitted

Precautions when turning the power switch on and off.

- When the data is changed using the edit keys or trim levers, wait at least two seconds before turning off the power. If the power is turned off within two seconds after the data is changed, the new data will not be written to memory.

- If the power switch is quickly switched from the DISP mode to the PWR ON mode or vice versa, the switch error shown at the right may be generated. If this occurs, cycle the power.

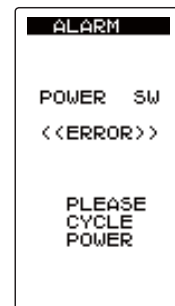

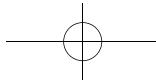

Display when power switch is turned on

Power switch turned on



Before Using

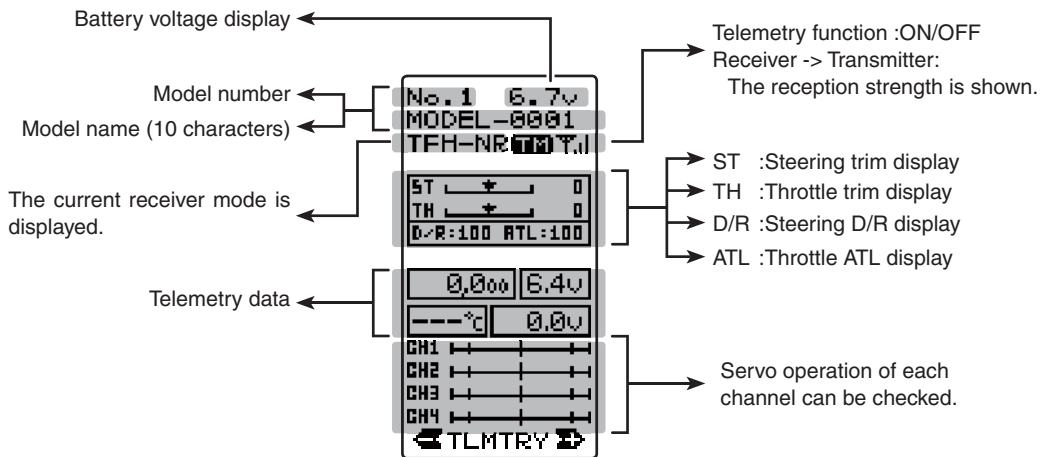

Beep confirmation sound is generated and the HOME screen shown below appears.

LCD Screen Contrast

The LCD screen contrast can be adjusted. (For more information, see page 101.)

Caution

Do not adjust the contrast so that the LCD is too bright or too dark.
When the display cannot be read due to a temperature change, data cannot be set.

Power Off Forgotten Alarm

When the steering wheel, throttle trigger, push switch, or edit button are not operated for 10 minutes (default), an alarm sounds and "NOT OPERATED FOR A LONG TIME" is displayed on the LCD screen.

When the steering wheel, throttle trigger, push switch, or edit button are operated, the alarm is reset. If the system is not to be used, turn off the power.

The function can be deactivated at the system menu (p.101).

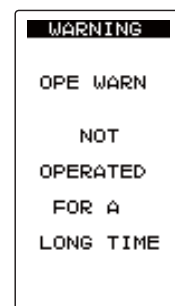

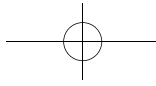

Digital Trim Operation

(Initial settings: DT1: Steering trim, DT2: Throttle trim,)

Operating by the lever: Push the lever to the left or right (up or down) The current position is displayed on the LCD screen.

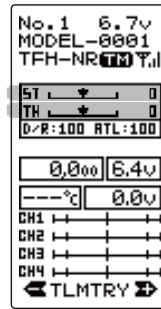
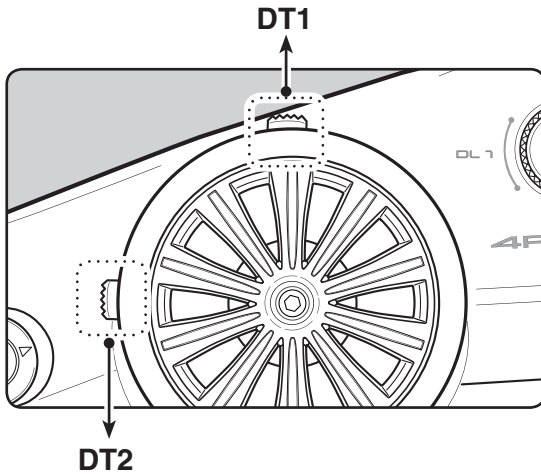

Steering trim display
Throttle trim display

Before Using

- Each step is indicated by a tone.
- When the trim exceeds the maximum trim adjustment range, the beep will change and the servo will not move any farther.
- Trim lever adjustments have no effect on the maximum servo travel. This prevents the linkages from binding when adjustments are made.

Trim Operation

With the center trim feature, trim adjustments have no effect on the maximum servo travel. This prevents the linkages from binding when adjustments are made.

Grip Lever Operation

(Initial setting: DT3; Steering D/R, DT4; ATL)

Operate the dials by turning them. The current set value is displayed on the LCD screen.

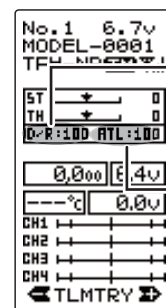
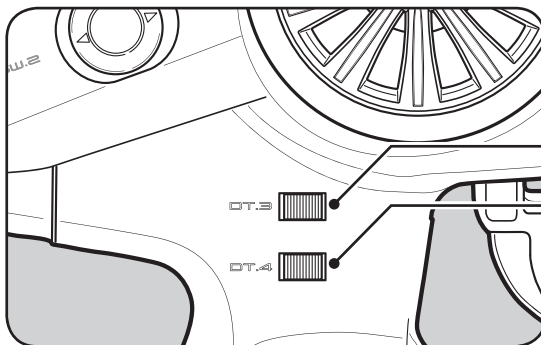

Steering D/R display
ATL display

- Each step is indicated by a tone.
- When the trim exceeds the maximum trim adjustment range, the tone will change pitch and the servo will not move any farther.

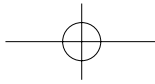

Mechanical ATL Adjustment

Make this adjustment when you want to decrease the stroke of the brake (back) side of the throttle trigger for operation feel.

Adjustment

1 Using a 2.5mm hex wrench, adjust the trigger brake (reverse) stroke. (The screw moves the throttle trigger stopper.)

- When the screw is turned clockwise, the stroke becomes narrower. Adjust the stroke while watching the screw.

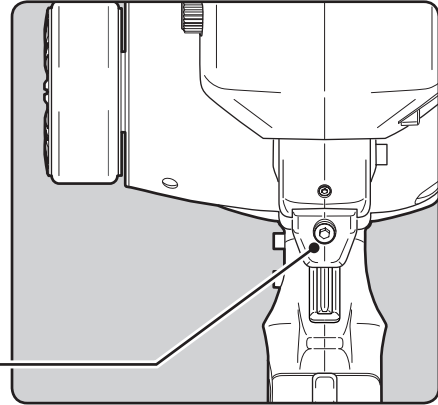

Mechanical ATL adjusting screw

Note:

Once you have changed the mechanical stroke on the brake side, be sure to adjust the scale of the throttle channel accordingly by using the "Adjuster Function" (page 105).

Due to this change, you also need to adjust in most cases the travel of the throttle servo by using "End point Adjuster".

Before Using

Wheel & Trigger Tension Adjustment

Make this adjustment when you want to change the wheel or trigger spring's tension.

Adjustment

1 Using a 1.5mm hex wrench, adjust the wheel spring tension by turning the screw inside the adjusting hole in the arrow direction.

- The spring is set to the weakest tension at the factory.
- When the adjusting screw is turned clockwise, the spring tension increases.

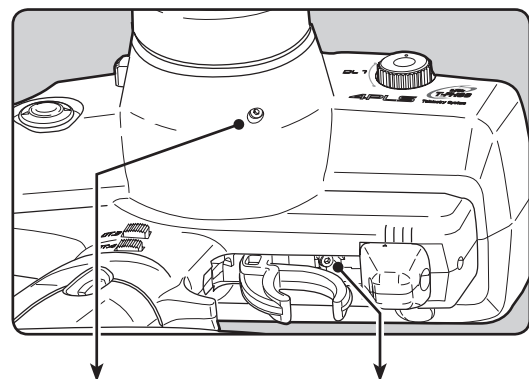

Wheel tension adjusting screw

Trigger tension adjusting screw

Note:

The adjustment range is up to 7 to 8 turns from the fully tightened (strongest) position. If turned farther than this, the adjusting screw may fall out.

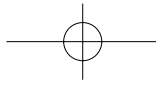

Trigger Slide Adjustment

The throttle trigger position can be moved forward and backward.

Adjustment

- 1** Using a 2.5mm hex wrench, loosen the trigger slide mounting screw by turning it slightly counterclockwise.
- 2** Using a 2.5mm hex wrench, turn the trigger slide adjusting screw, and adjust the trigger slide position within the marked range. When the adjusting screw is turned clockwise, the trigger slide moves away from the grip handle.
- 3** Retighten the mounting screw loosened at step 1 and fasten the trigger slide.

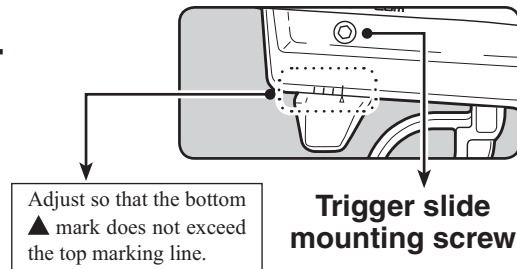

Trigger slide mounting screw

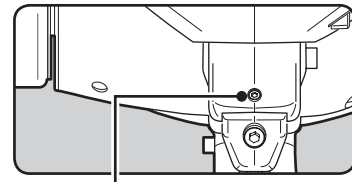

Trigger slide adjusting screw

Before Using

About Transmitter Antenna and Receiver

About The Transmitter Antenna

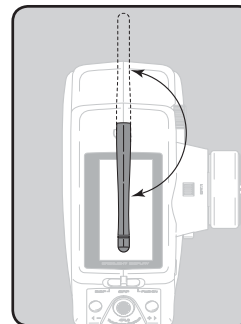
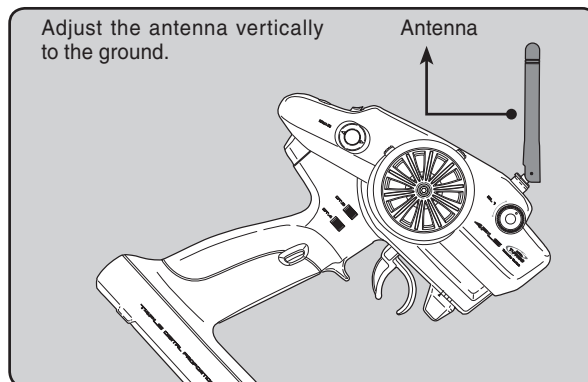

A

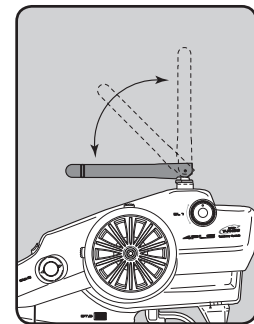

B

Antenna Moving Range

⚠ Warning

- ❗ **Adjust the antenna vertically to the ground.**
Otherwise, the operating range may become shorter.
- ⊘ **Never hold only the antenna.**
Hold the grip handle. Otherwise, the antenna may be damaged.
- ⊘ **The antenna position can be changed in the range as shown in figures A and B. However, please do not apply unnecessary force or shock.**
The internal cable may be damaged; thus transmitting distance decreases and it may cause malfunction.

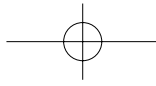

Receiver Terminology

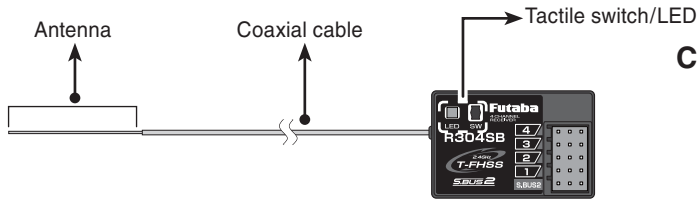

Connectors

4	:CH4 servo(CH4)
3	:CH3 servo(CH3)
2	:Throttle servo(CH2)
1	:Steering servo(CH1)
S.BUS2:Power /S.BUS2 connector	

The receiver power supply can be connected to the S-BUS2 connector or each of CH1-4.

Receiver Installation

Install the R304SB receiver on the car as follows:

The operating range may become shorter, depending on where the receiver and the antenna are mounted.

Before Using

⚠ WARNING

- ⊘ Do not cut or bundle the receiver antenna wire.
- ⊘ Do not bend the coaxial cable. It causes damage.
- ❗ Install the antenna in the higher place as shown in the figure.
- ❗ Put the antenna in the antenna tube to protect it.
- ❗ Keep the antenna as far away from the motor, ESC and other noise sources as you possibly can.
- ❗ Wrap the receiver with something soft, such as foam rubber, to avoid vibration. If there is a chance of getting wet, put the receiver in a waterproof bag or balloon.

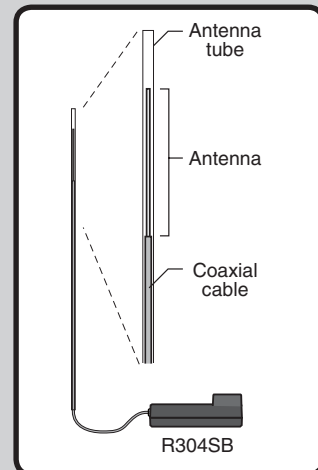

⚠ Caution

- ❗ Always use R304SB under the following conditions:
 - Battery :Power requirement Rated voltage 4.8~7.4V (dry cell battery cannot be used) / 3.5 to 8.4V useable
Matched to the ratings of the receiver and connected servo.
 - RX MODE:"T-FHSS(HIGH)" or "T-FHSS(NORM)" (See p.29 for setting method.)
 - Transmitter mode-"T-FHSS(HIGH)" mode :Futaba digital servo
 - Transmitter mode-"T-FHSS(NORM)" mode :Futaba all servo
- Under other conditions, the set will not operate, or the specified performance will not be displayed even if it operates. In addition, it may cause trouble with servos and other equipment. Futaba will not be responsible for damage, etc. caused by combination with the products of other companies.

Transmitter mode setting

Set the transmitter to the "T-FHSS(HIGH)" mode or "T-FHSS(NORM)" mode. See page 29 for a description of the setting method.

Note: However, digital servos (including BLS Series brushless servo) can only be used in the T-FHSS(HIGH) mode.

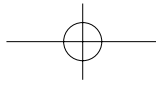

Installation

Receiver and Servo Connections

Connect the receiver and servos as shown below. Connect and install the receiver and servos in accordance with "Installation Safety Precautions" on the next page.

The figure shown below is an example. The method of connecting the motor controller to the motor and battery depends on the motor controller used. Purchase the motor controller and servos separately. The receiver also depends on the set.

Installation When An Electronic Speed Control Is Used

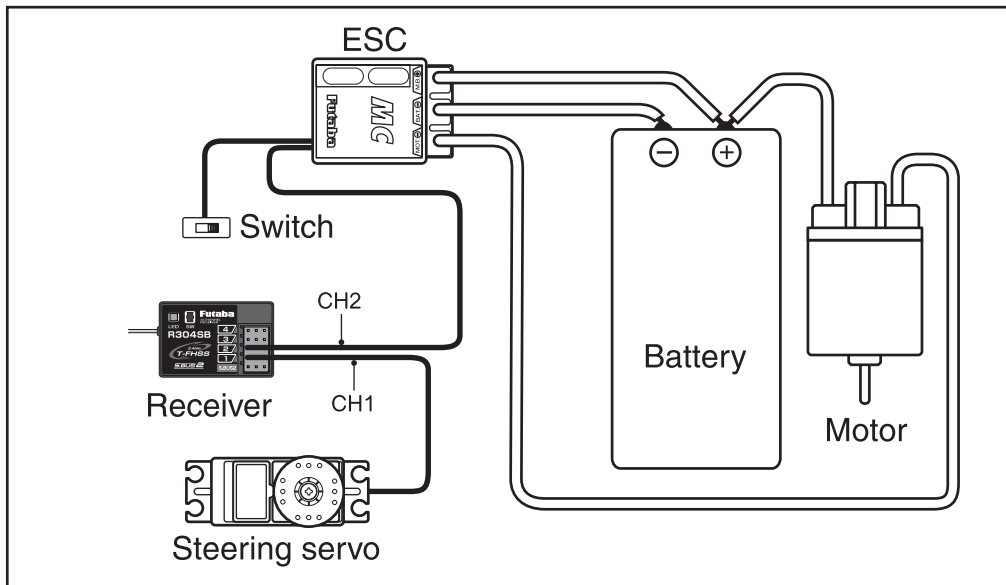

Installation

Installation For Gas Powered Models

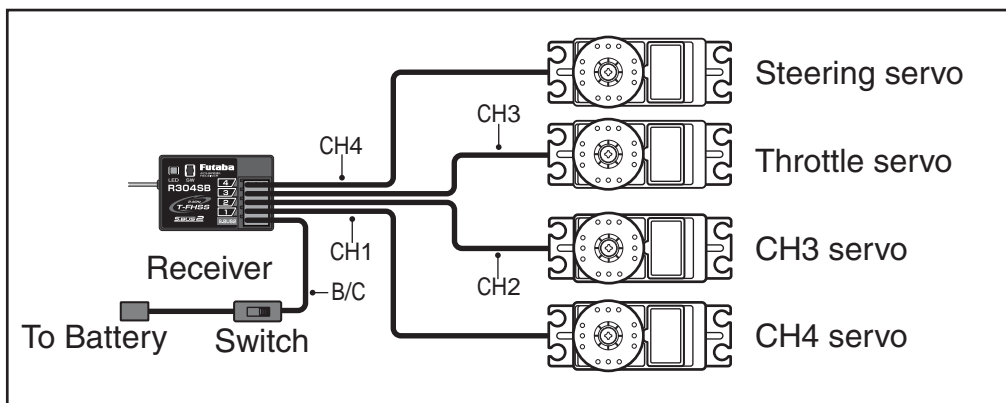

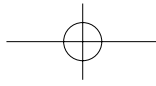

Installation Safety Precautions

Warning

Receiver (receiver antenna)

- ⊘ Do not cut or bundle the receiver antenna wire.
- ⊘ Do not bundle the receiver antenna wire together with the motor controller lead wire.
- ❗ Keep the receiver antenna wire at least 1cm away from motor, battery, and other wiring carrying heavy current.
- ❗ Install the receiver antenna holder as closely as possible to the receiver.

If the antenna wire is cut, bundled, or routed near a noise source, the receiving sensitivity will drop, the running (sailing) range will decrease, and you may lose control of the model.

*Noise is transmitted through metal, carbon, and other conductive material, so keep the receiver antenna wire away from such parts.

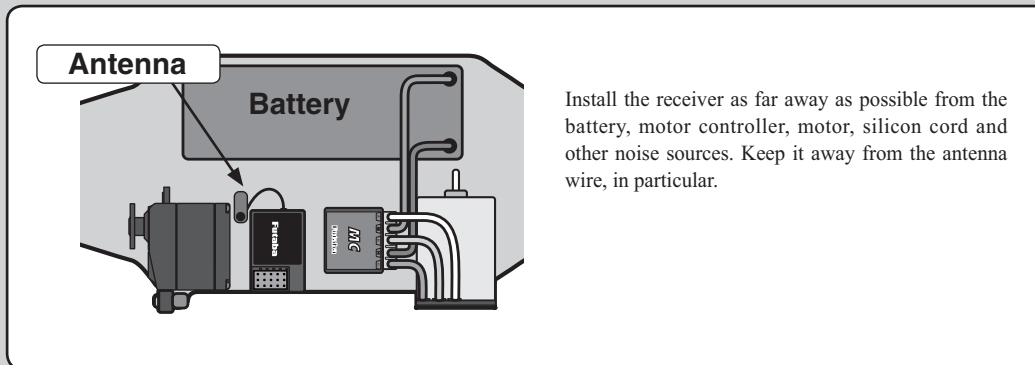

Installation

Receiver vibration-proofing / waterproofing

(Car)

- ❗ Vibration-proof the receiver by wrapping it in foam rubber or other vibration-absorbing material and mount it with thick double-sided tape.
- ❗ When using the receiver holder supplied with the model kit, mount the holder to the chassis through a rubber grommet.

(Boat)

- ❗ Vibration-proof the receiver by wrapping it in foam rubber or other vibration-absorbing material. Also waterproof the receiver by sealing it in a plastic bag.

If the receiver is exposed to strong vibration and shock, it will operate erroneously due to the invasion of water drops and you may lose control of the model.

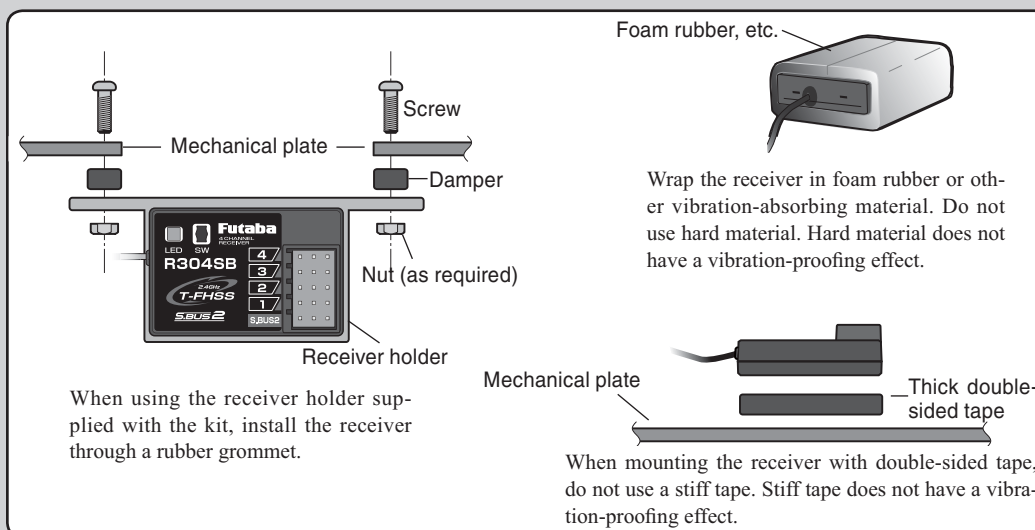

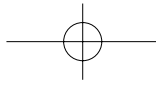

⚠ Warning

Connector Connections

- ❗ Be sure the receiver, servo, battery and connectors are fully and firmly connected.

If vibration from the model causes a connector to work loose while the model is in operation, you may lose control.

Servo Installation

- ❗ When you install the servos, always use the rubber grommets provided in servo hardware bags. Mount the servos so they do not directly come in contact with the mount.

If the servo case comes in direct contact with the mount, vibration will be directly transmitted to the servo.

If this condition continues for a long time, the servo may be damaged and control will be lost.

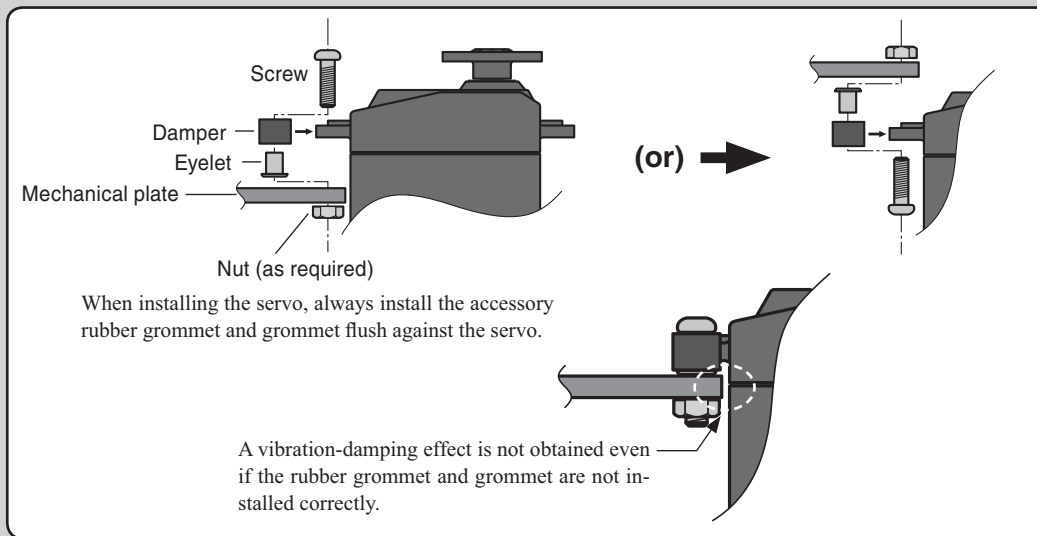

Installation

Servo Throw

- ❗ Operate each servo over its full stroke and be sure the linkage does not bind or is loose.

The continuous application of unreasonable force to a servo may cause damage and excessive battery drain.

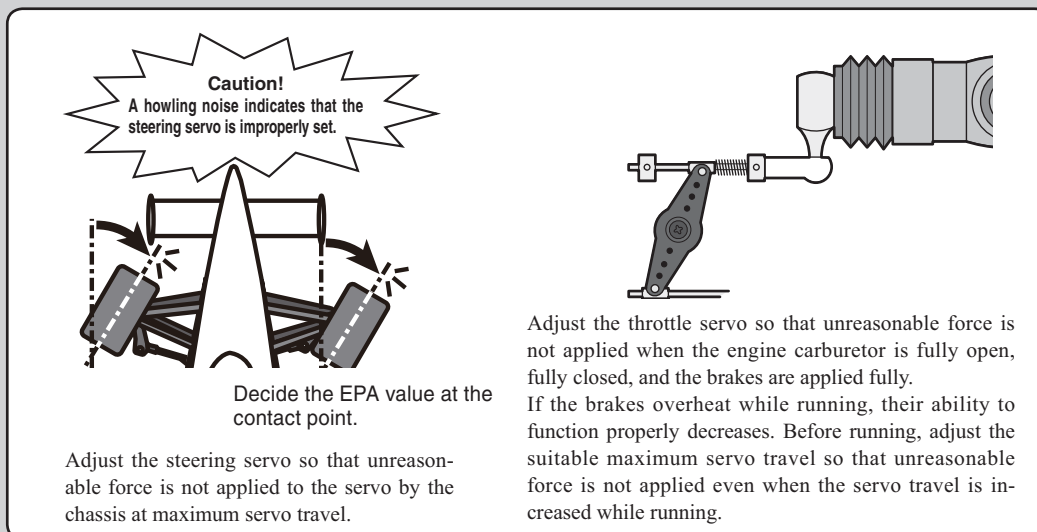

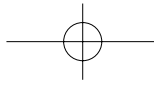

⚠ Warning

Electronic Speed Control

- ❶ Install the heat sinks where they will **not** come in contact with aluminum, carbon fiber or other parts that conduct electricity.

If the FET Amp (Electronic speed control) heat sinks touch other materials that conduct electricity a short circuit could occur. This could result in loss of control and damage to the system.

Motor Noise Suppression

- ❶ Always install capacitors to suppress noise when electric motors are used.

If capacitors are not properly installed you could experience erratic operation and reduced range as well as loss of control.

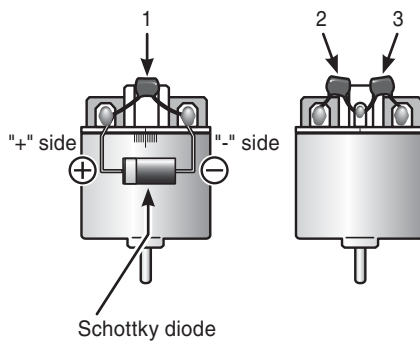

Motors with no suppressor capacitors, or inadequate suppression, may cause the receiver to malfunction. Always solder the capacitors supplied to your motor.

The Schottky diode improves the efficiency of the speed control / motor combination and provides extra protection to the brake FETs. The white ring must always face the positive side.

Installation

Other Noise Suppression Methods

- ❶ Be sure there are no metal parts in your model which under vibration can come in contact with other metal parts.

Metal to metal contacts under vibration will emit a high frequency noise that will affect the receiver's performance. You could experience erratic operation and reduced range as well as loss of control.

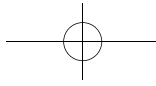

Initial Set-Up

Preparations (Transmitter)

Before setting the Transmitter functions, check and set items next.

(Display when power switch turned on)

When the power switch is turned on, the currently selected model number is displayed. Check if this number is the model number you want to set-up. To change the model number, use the Model Select function (See page 39).

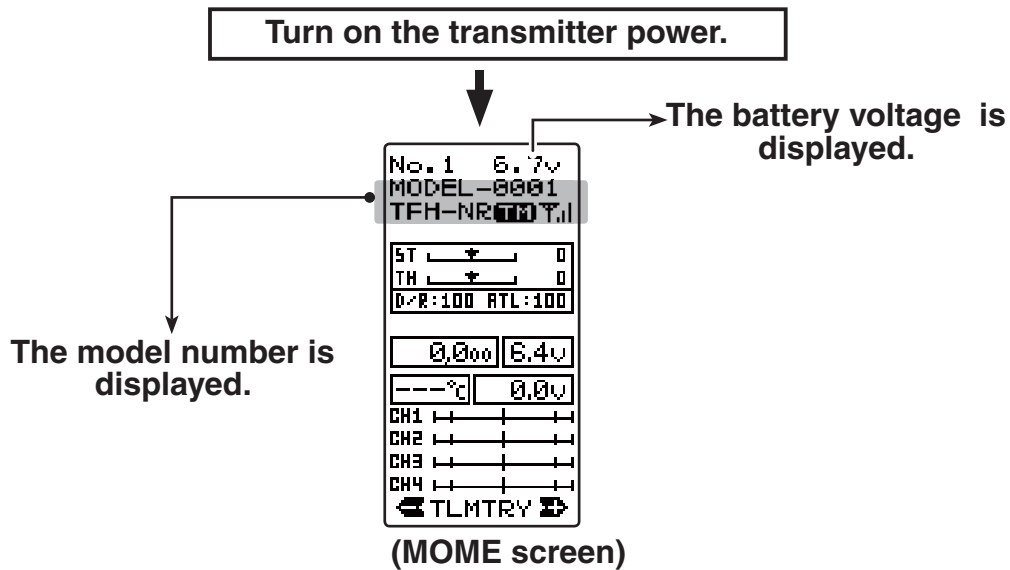

Receiver Type Check (RX MODE)

This mode sets the RX type of the transmitter to match the receiver and servos used.

The T4PLS transmitter uses the telemetry type T-FHSS ("TFH") system.

It can also use the conventional FHSS and S-FHSS ("SFH") systems. Because the R304SB receiver supplied with the T4PLS uses the telemetry type T-FHSS ("TFH") system, its RX type must be set to the T-FHSS high speed mode ("TFH-HI") or the T-FHSS normal mode ("TFH-NR"). Never use analog servos when the RX type was set to the T-FHSS ("TFH") 2.4GHZ system high speed mode "TFH-HI" or the S-FHSS (SFH) high speed mode "SFH-HI". The servos may be damaged. For example, if analog servos are used with a telemetry type T-FHSS receiver (R304SB, etc.), the RX type must be set to "TFH-NR", and if analog servos are used with an S-FHSS receiver (R2104GF, R204FG-E, etc.), the RX type must be set to S-FHSS ("SFH-NR") system normal mode or FHSS ("FHSS") system. When using digital servos (including BLS Series brushless servos), any RX type can be used.

When a dedicated FHSS receiver (R603GF/R2004GF) is used, it will not operate if the RX type is not set to "FHSS".

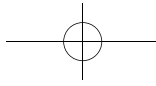

If the receiver used and the RX type settings are different, change the RX type using the "RX MODE" function. Which RX type is set can be checked at the HOME screen.

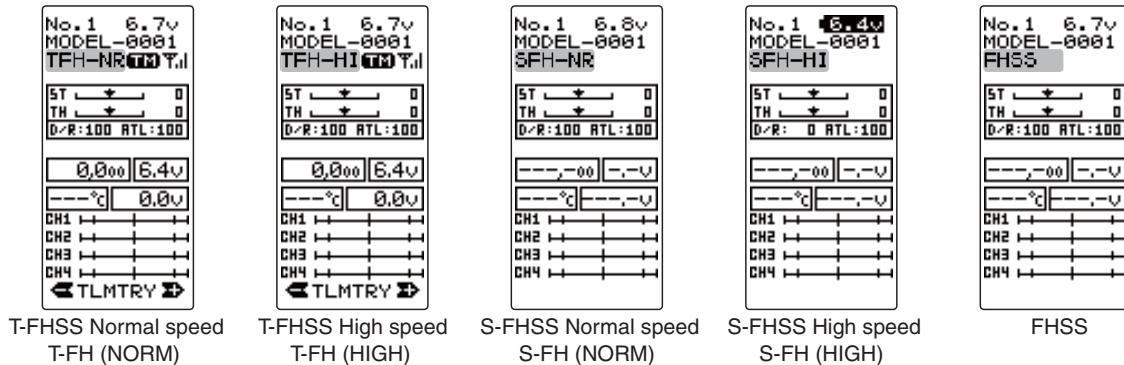

Receiver Type Change & How To Link

The first operation described below sets the RX type. Next, the transmitter and receiver are linked and the transmitter ID number is memorized at the receiver so that signals from other transmitters will not be received. The telemetry type T-FHSS also simultaneously memorizes the ID number of the receiver at the transmitter so that data from other receivers will not be received.

The RX type setting and transmitter and receiver linking methods are described here. Refer to the figure at the right for the edit buttons used.

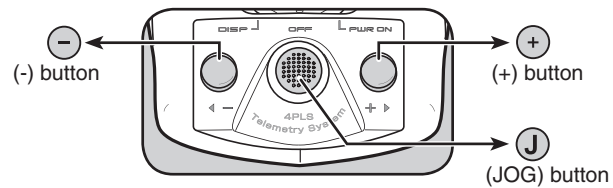

1 Set the transmitter power switch to DISP. Select "RX Setting" by (JOG) button up or down operation, and display the "RX MODE" screen by pressing the (JOG) button.

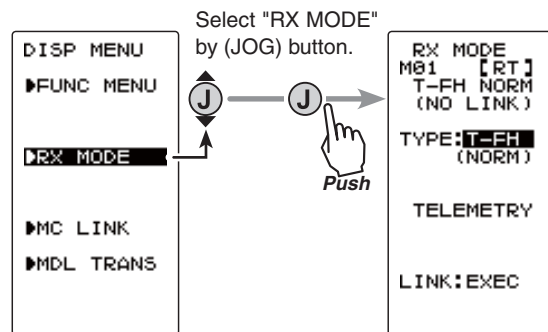

2 Move the cursor to "TYPE: ----" by (JOG) button up or down operation, and select the RX type with the (+) button or (-) button.

When the (JOG) button is pressed for approximately 1 second, an electronic sound is generated and setting ends.

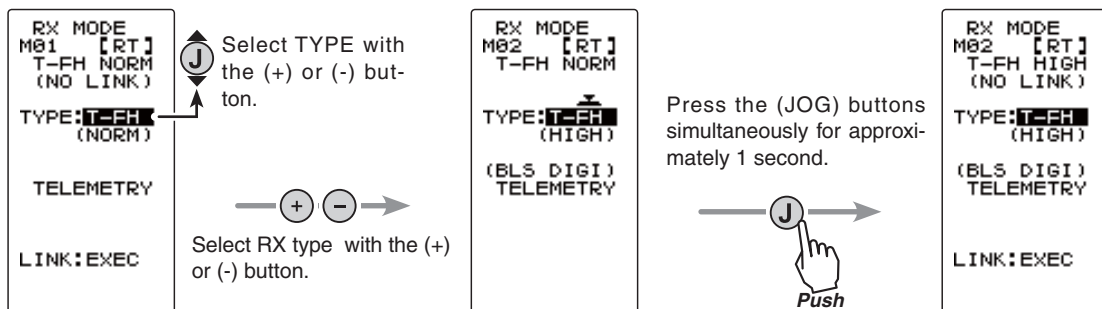

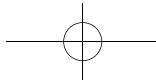

*When using an FHSS (R603GF/R2004F, etc.) or S-FHSS(SFH) system (R2104GF, R204GF-E, etc.) receiver, after the end of setting up to here set the transmitter power switch to OFF and go to "**Receivers other than T-FHSS**" on page 32.

3 Bring the transmitter and receiver to within 50cm of each other (do not allow the antennae to touch) and turn on the receiver power.

4 Move the cursor to "LINK: EXE" by transmitter T4PLS's (JOG) button up or down operation.

When the (JOG) button is pressed for approximately 1 second, "PUSH RX LINK SW" appears on the screen and 20 seconds countdown begins. Countdown can be canceled at any time by button up down or left right operation.

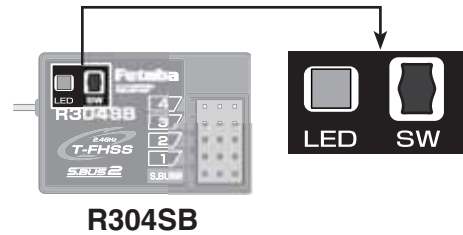
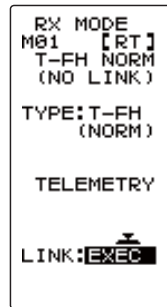

5 During 20 seconds countdown, push up the receiver side tact switch for approximately 2 seconds. The LED will begin to blink red. After the receiver LED switches from blinking red to green → red steady light, the T4PLS generates an electronic beeping sound, and "LINK:OK" and "COMPLETE!" appear on the screen, reading of the mutual IDs ends and the memorized receiver ID number appears on the T4PLS screen. If an error screen was displayed, linking failed. Retry linking. If the transmitter and receiver are linked normally, set the power switch to the OFF position and then return it to the PWR ON position. If the receiver LED lights green, linking was successful. Actually check servo operation.

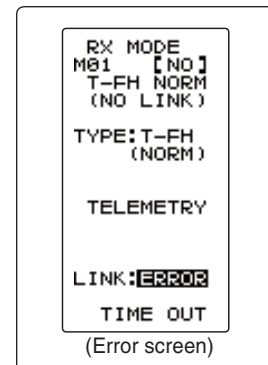
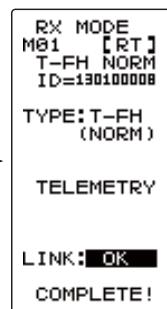
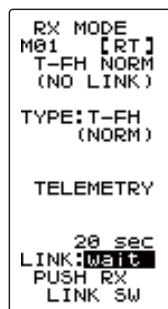

Initial Set-Up

*The T4PLS and a telemetry type T-FHSS receiver (R304SB, etc.) mutually memorize the combined ID linked last at each model memory.

Since the T4PLS can memorize only 1 receiver ID at each model memory, multiple T-FHSS receivers cannot be used with the same model memory. Besides, when changing the receiver at the same model memory, re-link the previously linked receiver.

When using multiple telemetry type T-FHSS receivers, link and combine them with each T4PLS model memory.

However, multiple receivers cannot be linked to multiple model memories.

The telemetry function communications status can be checked at the T4PLS HOME screen.

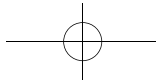

The telemetry ON/OFF and communication status can be checked at the HOME screen.

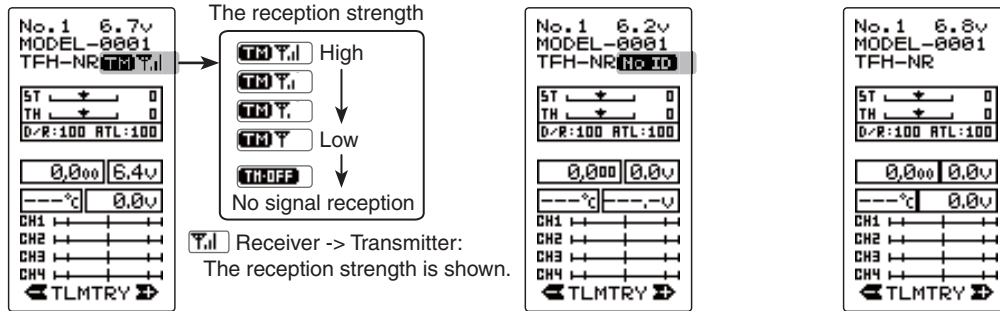

- Telemetry function :ON
- Receiver ID setting complete
- Data receiving sensitivity display
- **TH:OFF** shows that data cannot be received because it is outside the data receiving range or because of the effects of an obstruction or the receiver power is OFF after receiver ID check.

- Telemetry function :ON
- Receiver ID before setting or ID mismatch
- When the receiver ID is set, before ID check in the receiver power OFF stat

Telemetry function :OFF

RECEIVERS OTHER THAN T-FHSS

- 1 Bring the transmitter and the receiver close to each other, within 20 inches (half meter).
- 2 Turn on the transmitter.
- 3 Turn on the receiver.
- 4 Push the tactile switch of the receiver.
When the link is complete, the LED in the receiver changes to solid green.

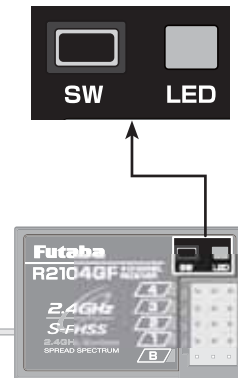

Initial Set-Up

Precaution:

If there are many Futaba S-FHSS/FHSS systems turned on in close proximity to the R2104GF, your receiver might not link to your transmitter. In this case, even if the receiver's LED stays solid green, unfortunately the receiver might have established a link to one of other transmitters. This is very dangerous if you do not notice this situation. In order to avoid the problem, we strongly recommend you to double-check whether your receiver is really under control by your transmitter by giving the stick input and then checking the servo response.

*Please refer to the table below for LED status vs receiver's condition.

LED status vs receiver's condition:

No signal reception	Red : On
Receiving signals	Green: On
Receiving signals, but ID is unmatched.	Green: Blink *1

*1: LED could be change to red during intermittently during data processing.

Warning

- ❗ After the linking is done, please cycle receiver power and check if the receiver to be linked is really under the control of your transmitter.
- ⚠ Do not perform the linking procedure with motor's main wire connected or the engine operating as it may result in serious injury.

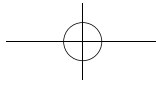

Throttle Mode Check

The throttle servo travel can be set to 5:5 or 7:3 for throttle trigger operation as required by the throttle mode function (page 80).

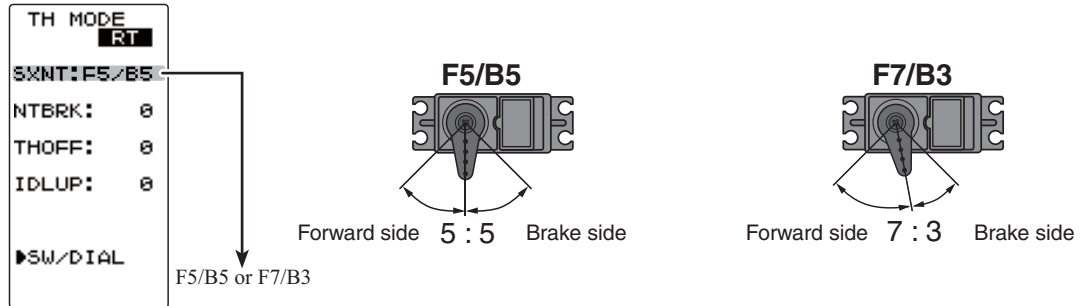

Trims Initial Set-Up

- Steering trim (DT1) check

On the initial set-up, steering trim is assigned to the DT1 trim lever above the steering wheel. Operate the lever and make sure the marker moves on the ST graph. If default has been changed, test steering trim in its new location. After checking the trim, set the trim display to the center (N) position.

- Throttle trim (DT2) check

On the initial set-up, throttle trim is assigned to the DT2 trim lever on the left side of the steering wheel. Operate the lever and make sure the marker moves on the TH graph. If the default has been changed, test the throttle trim in its new location. After checking the trim, set the trim display to the center (N) position.

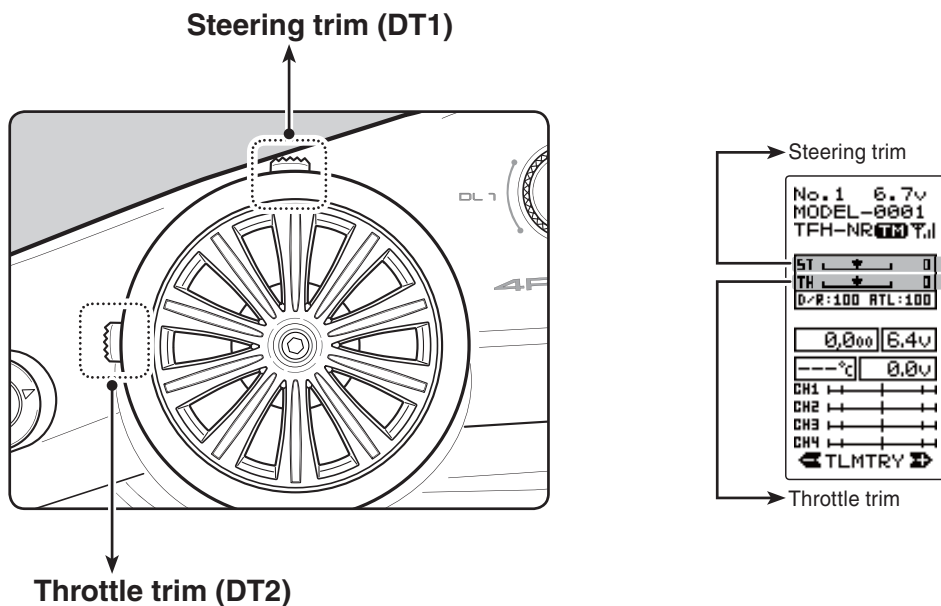

Initial Set-Up

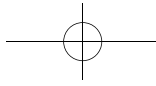

- Steering dual rate (DT3) check

At initial set-up, steering dual rate (D/R) is assigned to the DT3 lever, at the grip of the transmitter. Operate the DT3 and check if the D/R value displayed on the screen changes. After checking D/R, set the steering dual rate to 100%.

- Throttle ATL (DT4) check

At initial setting, throttle ATL (ATL) is assigned to to the DT4 lever, below the DT3. Operate the DT4 and check if the ATL value displayed on the screen changes. After checking ATL, set throttle ATL to 100%.

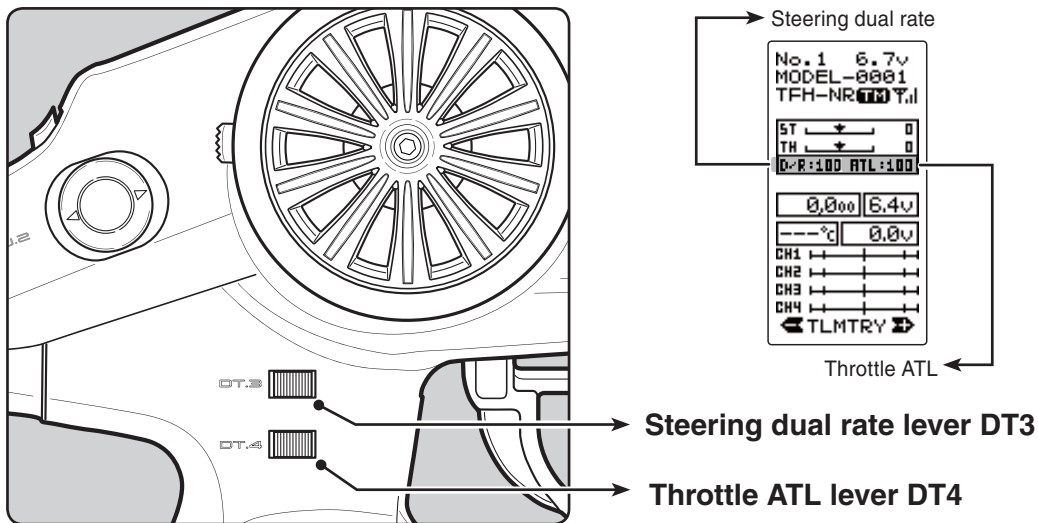

Initial Set-Up

(Set-Up Procedure When Installed In a Car)

When installing the servos in a car, performing function set-up in the following order is recommended.

- 1** Perform step 1 to Trims Initial Set-Up of Preparations on the preceding page.
- 2** Set the servo direction of operation using the Reverse function. (p.44)
 - The servo installation method and linkage direction depend on the kit. Therefore, the servo operation direction may have to be reversed relative to transmitter operation. Before installing the servo, check the operating direction and set it using the Reverse function.
- 3** Set the subtrim and adjust the servo neutral point. (p.45)
- 4** Set the trigger travel by adjusting the throttle trigger mechanical ATL to your liking. (p.22)
 - When the stroke was adjusted, compensate the throttle by adjuster function (See page105).
- 5** Set EPA of each channel and adjust the servo throw (travel). (p.46)

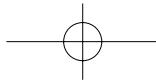

Function Map

Operation Of Screen

In this instruction manual, Edit Buttons are represented by the symbols shown below. The (JOG) button can be operated in the 4 directions up, down, left, and right.

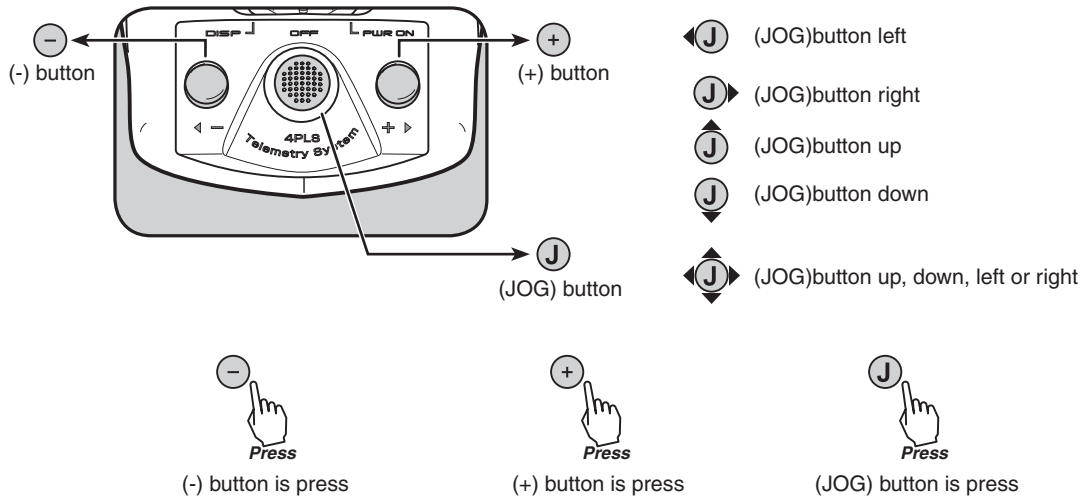

Calling The Menu Screen

Refer to the below map for the method of displaying the function setting menu screen from the PWR ON initial screen or DISP (display) screen and the method of returning from the menu screen to the PWR ON initial screen or DISP (display) screen.

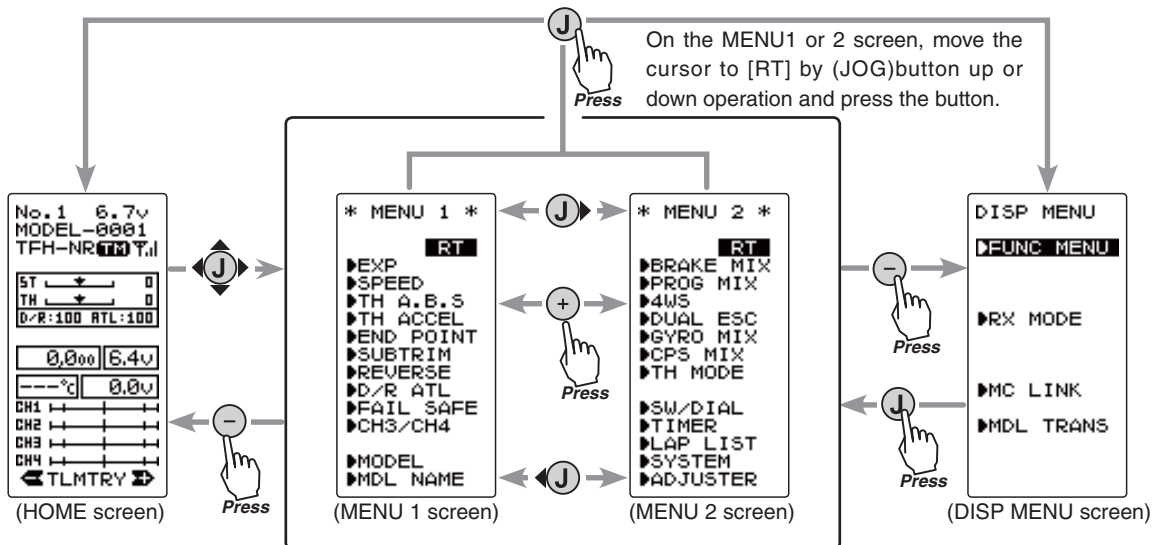

Function Map

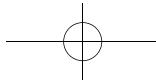

Selecting Items On The Menu Screen

The item indicated by the reverse displayed cursor on the screen is selected.

The cursor is moved by (JOG) button up or down operation. The cursor movement figure shown below is an example of the MENU 1 screen. However, movement of the cursor is the same at all the screens.

For instance, if the (JOG) button is pressed when the cursor is at the end point (EPA) on the MENU 1 screen, the end point (END POINT) function setting screen appears.

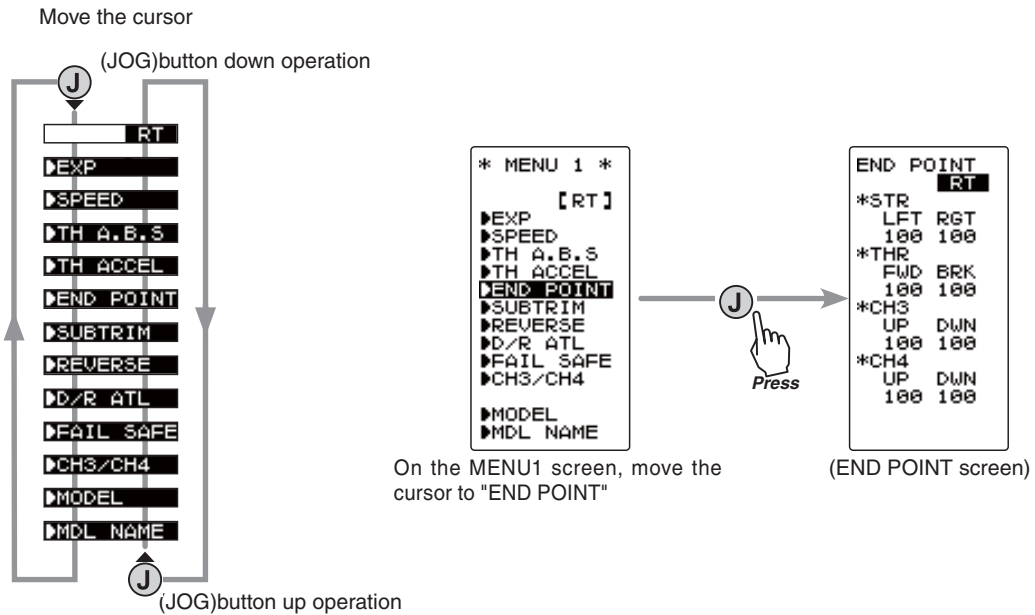

Value Of Each Function And Changing The Set Value

Values, settings, and other data on all the function setting screens are changed with the (+) and (-) buttons.

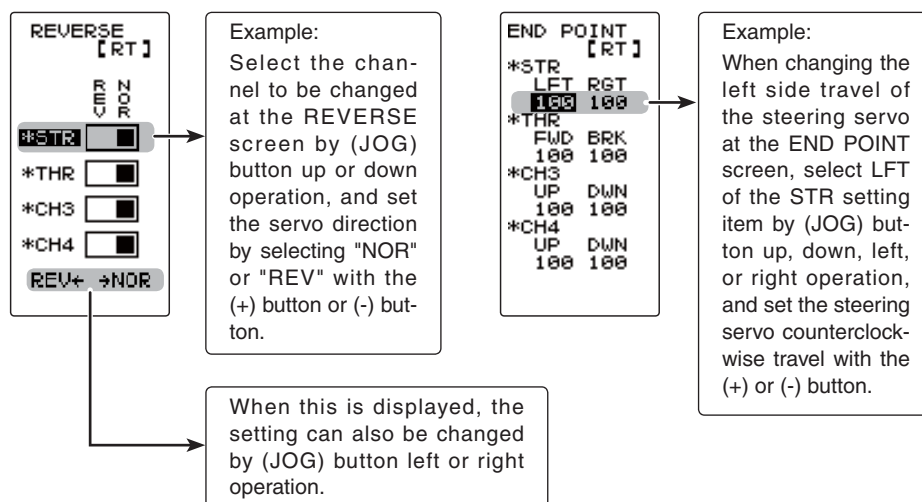

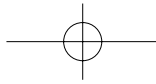

Basic Menu Japanese Katakana Character Display

On the system menu, the basic menu screen shown below can be displayed in Japanese katakana characters.

"KATAKANA" characters	Alphabetic characters
EXP	EXP
スピード	SPEED
TH A.B.S	TH A.B.S
アクセレーション	TH ACCEL
エンドポイント	END POINT
トリム	TRIM
リバース	REVERSE
D/R ATL	D/R ATL
フェイルセーフ	FAIL SFE
CH3/CH4	CH3/CH4
モデル	MODEL
モデルネーム	MDL NAME
ブレーキ MIX	BRAKE MIX
PROG MIX	PROG MIX
4WS	4WS
デュアルESC	DUAL ESC
ジャイロ MIX	GYRO MIX
CPS MIX	CPS MIX
THモード	TH MODE
SW/ダイヤル	SW/DIAL
タイマー	TIMER
ラップリスト	LAP LIST
システム	SYSTEM
アジャスター	ADJUSTER

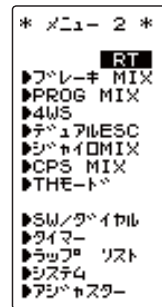
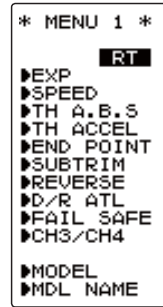
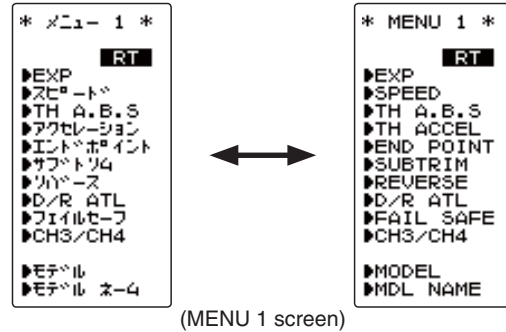

Changing the character

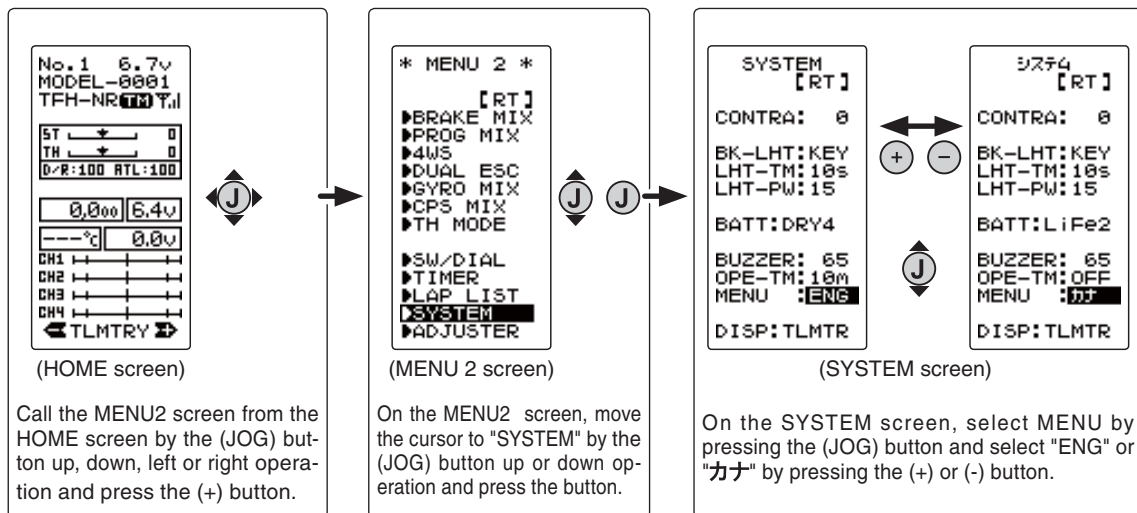

After changing the setting, return to the MENU2 screen by pressing the (JOG) button or return to the HOME screen by selecting [RT] and pressing the (JOG) button.

Function Map

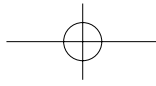

Function List		
Function Abbreviation	Description Of Function	Page No
RX MODE	Receiver type selection/linking with telemetry type T-FHSS system receiver	P-29
MODEL	Model memory call/ Model memory copy/ Model memory reset	P-39
MDL NAME	Model memory name set/modify, username set/modify	P-43
REVERSE	Servo operation reversing	P-44
SUBTRIM	Servo center position fine adjustment	P-45
END POINT	End point adjustment	P-46
FAIL SAFE	Fail safe, battery fail safe	P-49
EXP	Steering curve adjustment/ Throttle curve adjustment	P-51
SPEED	Steering servo delay/ Throttle servo delay	P-54
TH ACCEL	Function which adjusts the rise characteristic from the throttle neutral position	P-57
TH A.B.S	Pumping brake	P-59
CH3/CH4	Channel 3&4 servos operation position set/check	P-63
D/R ATL	Steering angle adjustment while running/ Brake side adjustment	P-64
SW/DIAL	Selection of functions operated by switch, digital dial and digital trim	P-65
BRAKE MIX	Front and rear independent brake control for 1/5GP car, etc.	P-68
PROG MIX	Programmable mixing between arbitrary channels	P-70
4WS MIX	4WS mixing	P-72
DUAL ESC	Front and rear ESCs mixing	P-74
GYRO ESC	The sensitivity of Futaba car rate gyros can be adjusted.	P-76
CPS ESC	The CPS-1 of Futaba LED controller can be adjusted.	P-78
TH MODE	Throttle servo forward side and brake side operation rate setting/ Neutral brake/ Idle up at engine start/ engine cut off by switch	P-80
MC LINK	MC851C/602C/402CR/950CR/940CR/960CR Link software setting function	P-86
MDL TRANS	Data copy from T4PLS to another T4PLS	P-92
TIMER	Up, down, or lap timer	P-94
LAP LIST	Lap timer data (lap time, total time) check	P-100
SYSTEM	LCD contrast/backlight/Battery type/buzzer/power off forgotten alarm/Basic menu character display /HOME screen display mode	P-101
ADJUSTR	Steering wheel and throttle trigger correction	P-105
TELEMETRY	Displays the status during running from each sensor unit at the transmitter and records the status as log data	P-107

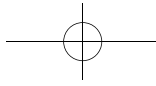

Model "MODEL"

Forty model data (data for 40 R/C cars) can be saved in the T4PLS transmitter. This menu selects the model, copies data between models.

Model Menu Display

The MENU 1 screen is displayed by (JOG) button up, down, left, or right operation at the HOME screen.

The display can be switched to the MODEL screen by selecting "MODEL" and performing (JOG) button up or down operation.

The display can be switched to the HOME screen by switching from the MODEL menu screen to the MENU 1 screen by pressing the (JOG) button and then pressing the (-) button at the MENU 1 screen.

When the (JOG) button is pressed from the MODEL menu screen, the display switches to the MENU1 screen and can then be switched to the HOME screen by pressing the (-) button from the MENU1 screen.

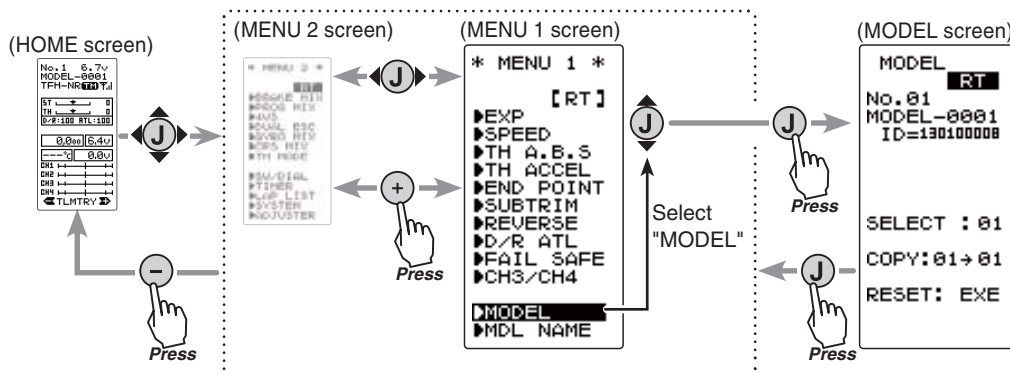

Setting item

- SELECT :Model selection
- COPY :Model copy
- RESET :Model reset

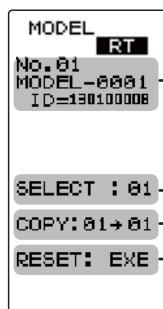

Current model # and model name
ID of T-HSS receiver linked last at this model

- Model selection function.
- Model copy function.
- Model reset function.

When a T-FHSS receiver is not linked with a model whose RX type is set to T-FHSS, (NO LINK) is displayed.
When RX type is set to S-FHSS or FHSS other than T-FHSS, nothing is displayed here

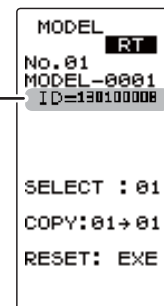

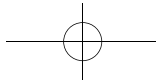

Model Selection "SELECT"

Forty model data (model data for 40 R/C cars) can be saved in the 4PLS transmitter and used when the relevant model data is called.

Using the model select function

- Display the MODEL screen by referring to P39.

1 (Selection of model select)

Move the cursor to "SELECT" by the (JOG) button up or down operation.

```
MODEL [RT]
No. 01
MODEL-0001
ID=13010000

SELECT : 01
COPY: 01 → 01
RESET: EXE
```

→ Move the cursor to select model # with the (JOG) button.

2 (Model #. selection)

Select the model number with the (+) or (-) button. "01" ~ "40" are displayed.

```
MODEL [RT]
No. 01
MODEL-0001
ID=13010000

MODEL-0002
(NO LINK)

SELECT : 02
COPY: 01 → 01
RESET: EXE
```

Model #.
01-40

→ Select model # with the (+) or (-) button.

3 (Model select execution)

Press the (JOG) buttons simultaneously for 1 second. A beeping sound is generated and the model is selected.

```
MODEL [RT]
No. 02
MODEL-0002
(NO LINK)

SELECT : 02
COPY: 02 → 02
RESET: EXE

COMPLETE!
```

→ Modified model # and model name

- Model change is complete when the model No. and model name on the screen change and "COMPLETE!" is displayed .

→ "COMPLETE!" is displayed.

4 When ending, move the cursor to [RT] by the (JOG) button, and return to the MENU1 screen by pressing the (JOG) button.

```
* MENU 1 *
[RT]
▶EXP
▶SPEED
▶TH A.B.S
▶TH ACCEL
▶END POINT
▶SUBTRIM
▶REVERSE
▶D/R ATL
▶FAIL SAFE
▶CH3/CH4

▶MODEL
▶MDL NAME
```

When the model changed, use after turning the transmitter power off and on.

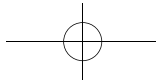

Model Copy "COPY"

The contents of the currently selected model data can be copied to another model.

Using the model copy function

- Display the MODEL screen by referring to P39.

1 (Selection of model copy)

Move the cursor to "COPY" by the (JOG) button up or down operation.

```
MODEL [RT]
No. 01
MODEL-0001
ID=130100008

SELECT : 01
COPY: 01 → 01
RESET: EXE
```

Move the cursor to "COPY" with the (JOG) button.

2 (Model #. selection)

Select the copy destination model number with the (+) or (-) button. "01" ~ "40" are displayed.

```
MODEL [RT]
No. 01
MODEL-0001
ID=130100008

MODEL-0002

SELECT : 01
COPY: 01 → 02
RESET: EXE
```

Model #.
01~40

The copy destination model # with the (+) or (-) button.

3 (Model copy execution)

Press the (JOG) buttons for about 1 second. A beeping sound is generated and the model is selected.

```
MODEL [RT]
No. 01
MODEL-0001
ID=130100008

MODEL-0001

SELECT : 01
COPY: 01 → 02
RESET: EXE

COMPLETE!
```

Model name is also copied.

"COMPLETE!" is displayed.

-Copying is complete when "COMPLETE!" is displayed on the screen.

4 When ending, move the cursor to [RT] by the (JOG) button, and return to the MENU1 screen by pressing the (JOG) button.

```
* MENU 1 *
[RT]
▶EXP
▶SPEED
▶TH A.B.S
▶TH ACCEL
▶END POINT
▶SUBTRIM
▶REVERSE
▶D/R ATL
▶FAIL SAFE
▶CH3/CH4

MODEL
▶MDL NAME
```

Function

Model "MODEL"

41

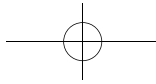

Model Reset "RESET"

This function resets and initializes the contents of the currently selected model data. However, the adjuster function (ADJUSTER), system setting (SYSTEM), and type of receiver mode (TYPE) are not initialized.

Using the model reset function

- Display the MODEL screen by referring to P39.

1 (Selection of model reset)

Move the cursor to "RESET" by the (JOG) button up or down operation.

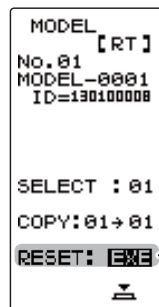

Move the cursor to "RESET" with the (JOG) button.

2 (Model reset execution)

Press the (JOG) buttons for about 1 second. A beeping sound is generated and the model is selected.

-Resetting is complete when "COMPLETE!" is displayed on the screen.

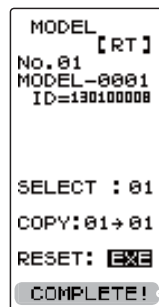

"COMPLETE!" is displayed.

3 When ending, move the cursor to [RT] by the (JOG) button, and return to the MENU1 screen by pressing the (JOG) button.



Function

The set RX type and T-FHSS receiver ID remain even if the model is reset. The same receiver can be used as is without re-linking

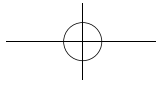

Model Name "MDL NAME"

This function allows you to assign a ten character name to each model memory and user name.

Display to "MDL NAME" screen by the following method:

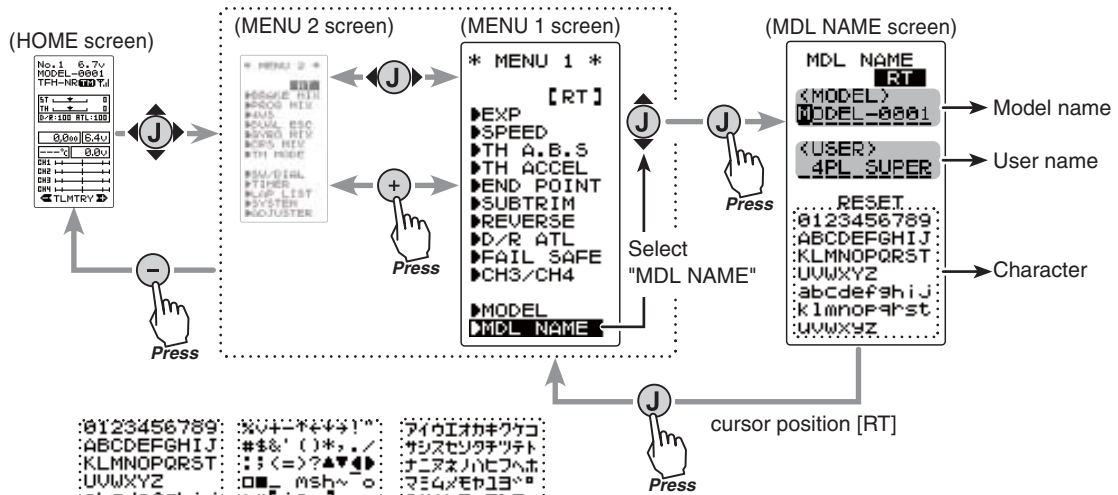

When (JOG) button left or right operation is performed from both the left and right ends of the character list, the page (all 3 pages) is changed and the character set is selected.

(KATAKANA of the 3rd page is displayed when "KANA" is set by the "SYSTEM" function "MENU".)

Setting the model name and user name

- 1** (Move the cursor to the character you want to change.)
Select the model name character you want to set or change by moving the cursor by the (+) or (-) button. The selected character blinks.
- 2** (Selecting the character to be used)
Select the character to be used from the character list at under side of the screen by the (JOG) button up, down, left, or right operation. The selected character blinks. After selecting the character to be used, press the (JOG) button. The character is entered and the model name or user name character row moves to the right.
Also move the cursor to "RESET" by the (JOG) button up, down, left, or right operation, and press the buttons for about 1 second. A beeping sound is generated and the model name is initialized to the factory setting.
- 3** When ending, move the cursor to [RT] by the (JOG) button, and return to the MENU1 screen by pressing the (JOG) button.

Move the cursor to the character you want to change by (+) or (-) button.

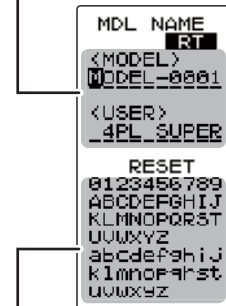

Select the character by (JOG) button.

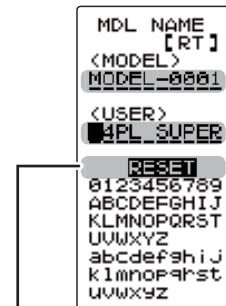

Move the cursor to "RESET" by the (JOG) button up or down operation.

Function

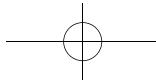

Servo Reverse "REVERSE"

(All channel)

This function reverses the direction of operation of the servos related to transmitter steering, throttle, and channel 3 /4 operation.

However, when the position set by trim or subtrim shifts from the center, the center becomes the opposite side.

Display to "REVERSE" screen by the following method:

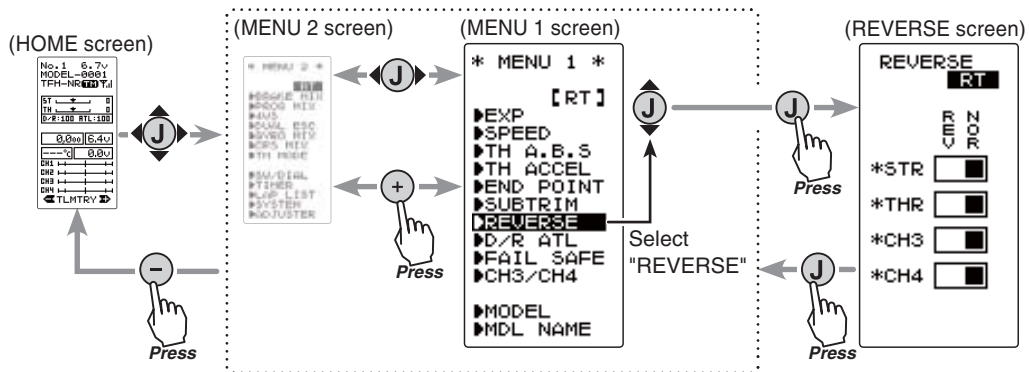

Setting item

- STR :Steering (1st channel)
- THR :Throttle (2nd channel)
- CH3 :3rd channel
- CH4 :4th channel

Servo Reverse Function Setting

(Preparation)

- Select the channel to be set by the (JOG) button up or down operation.

1 (Servo reverse setting)

Use the (+) or (-) button to reverse the servo operation direction.

NOR/REV can also be set by (JOG) button left or right operation

(Each channel can be set similarly.)

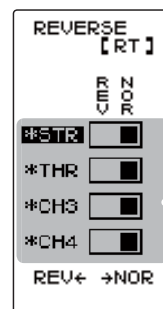

Move the cursor to "STR, THR, CH3 and CH4" with the (JOG) button.

Select button

- Select with the (+) or (-) buttons.

2 When ending, move the cursor to [RT] by the (JOG) button, and return to the MENU1 screen by pressing the (JOG) button.

Function

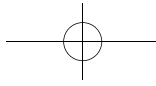

Subtrim "SUBTRIM"

(All channel)

Use this function to adjust the neutral position of the steering, throttle, channel 3 and channel 4 servos.

*Subtrim adjusts the entire range of the servo in the set direction.

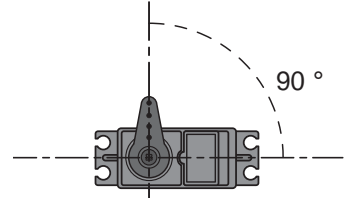
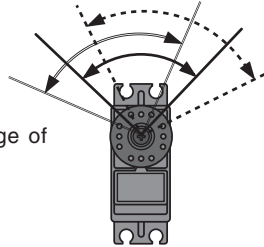

Use to adjust the neutral position

Display to "REVERSE" screen by the following method:

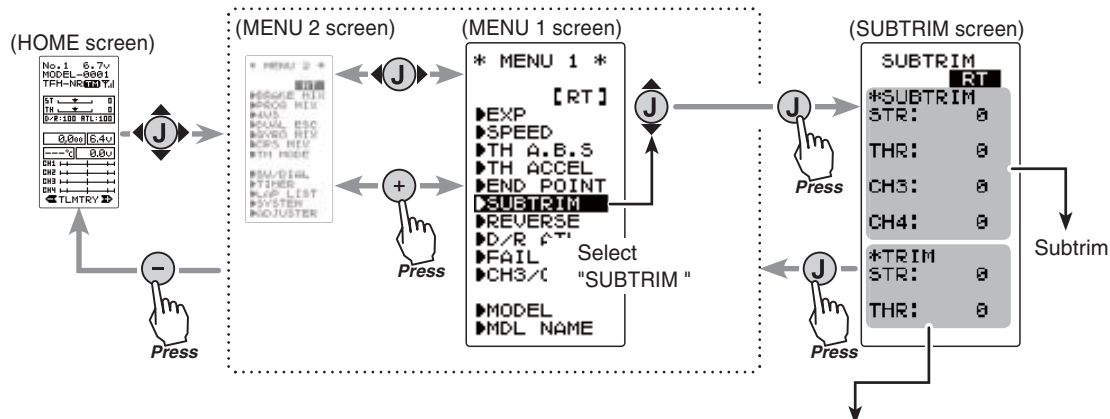

Steering and throttle center trim
 When assigning DT1, DT2, or other digital trimming to another function, make adjustments at this screen.

Subtrim adjustment

(Preparation)

- Set the steering and throttle digital trims to the neutral "0" position. Set CH3 and CH4 to the center "0" position.

Setting item

- STR :Steering (1st channel)
- THR :Throttle (2nd channel)
- CH3 :3rd channel
- CH4 :4th channel

1 (Subtrim adjustment)

Use the (+) or (-) button to adjust the center.
 (Each channel can be set similarly.)

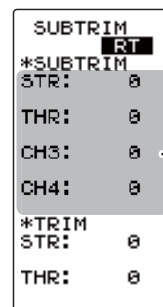

Move the cursor to "STR, THR, CH3 and CH4" with the (JOG) button.

Adjust button

- Adjust with the (+) and (-) buttons.
- Return to the initial value "0" by pressing the (+) and (-) buttons simultaneously for about 1 second.

Subtrim

- ST :L100~R100
- TH :B100~F100
- CH3 :-100~+100
- CH4 :-100~+100
- Initial value : 0

Function

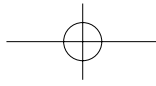

End Point Adjuster "END POINT"

(All channel)

Use this when performing left and right end point adjustments, throttle high side/brake side operation amount adjustment, channel 3 and channel 4 servo up side/down side operation amount adjustment during linkage.

- Correct the maximum steering angle for left and right steering angles when there is a difference in the turning radius due to the characteristics, etc. of the vehicle.

Maximum steering angle

The EPA function basically determines the maximum steering angle of each channel. The functions shown below may have been adjusted or the operating range set by EPA function may be exceeded. Check the linkage each time the following functions are adjusted.

- Sub trim (all channels) P45
- Program mixing slave side (all channels) P70
- Idle up (throttle) P81
- Throttle dff, Engine Cut (throttle)..... P83
- Throttle acceration (throttle) P57

ATL trim

ATL trim allows adjustment of the brake side operation amount during operation. Therefore, when the operating angle is adjusted with throttle EPA, ATL trim must also be taken into account.

Warning

! Operate each servo over its full stroke and be sure the linkage does not bind or is not loose.

The continuous application of unreasonable force to a servo may cause damage and excessive battery drain.



Decide the EPA value at the contact point.

Adjust the steering servo so that unreasonable force is not applied to the servo by the chassis at maximum servo travel.

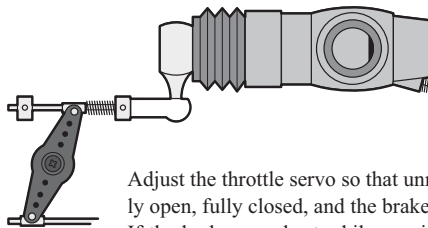

Adjust the throttle servo so that unreasonable force is not applied when the engine carburetor is fully open, fully closed, and the brakes are applied fully.

If the brakes overheat while running, their ability to function properly decreases. Before running, adjust the suitable maximum servo travel so that unreasonable force is not applied even when the servo travel is increased while running.

Function

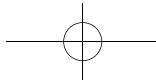

Display to "END POINT" screen by the following method:

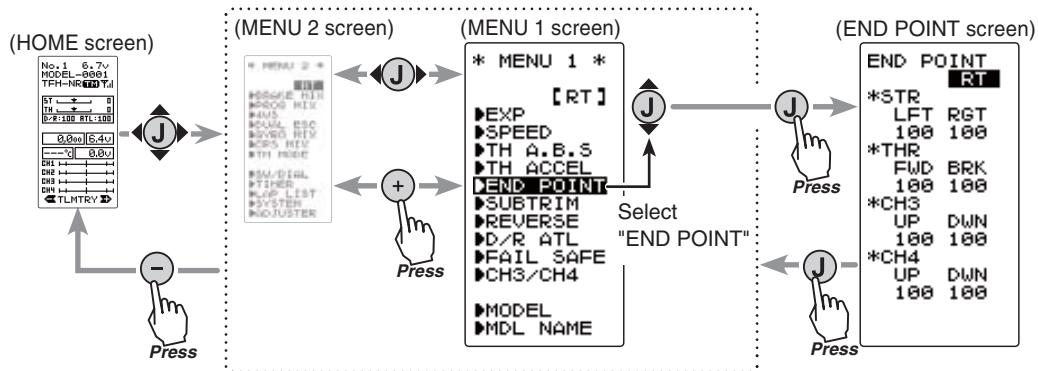

Setting item selection

(Steering and Throttle direction)

- The direction (STR LFT and STR RGT) linked with the steering wheel is switched.
- The direction (THR FWD and THR BRK) linked with the throttle trigger is switched.

Setting item (channel and direction)

- STR LFT :Steering (left side)
- STR RGT :Steering (right side)
- THR FWD :Throttle (forward side)
- THR BRK :Throttle (brake side)
- CH3/CH4 UP :3rd or 4th channel (up side)
- CH3/CH4 DWN :3rd or 4th channel (down side)

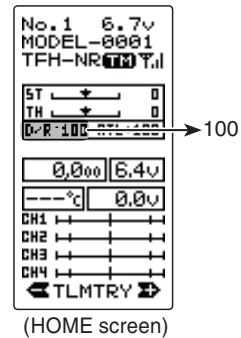

Steering (END POINT) adjustment

(Preparation)

- Before setup of the steering end point adjustment (END POINT), set the steering D/R rever (initial setup: DT3) to the maximum steering angle position 100%.
- Select the setting item "RGT" by the (JOG) button up, down, left, or right operation and make the following adjustments:

1 Steering (left side) adjustment

Turn the steering wheel fully to the left and use the (+) or (-) buttons to adjust the steering angle.

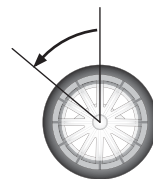

2 Steering (right side) adjustment

Turn the steering wheel fully to the right and use the (+) or (-) buttons to adjust the steering angle.

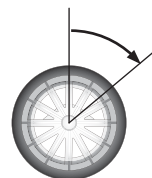

3 When ending, return to the MENU1 screen by pressing the (JOG) button.

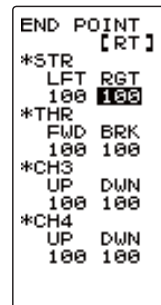

Adjust button

Adjust with the (+) and (-) buttons.

- Return to the initial value "100" by pressing the (+) and (-) buttons simultaneously for about 1 second.

Steering EPA

- STR LFT :0~120
- STR RGT :0~120
- Initial value :100

Function

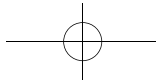

Throttle (END POINT) adjustment

(Preparation)

- Before setting the throttle end point adjustment (END POINT), set the throttle ATL lever (initial setup: DT4) to the maximum throttle angle position 100%.
- Select the setting item "FWD" by the (JOG) button up or down operation and make the following adjustments:

1 Throttle (forward side) adjustment

Pull the throttle trigger fully to the high side and use the (+) or (-) buttons to adjust the throttle angle. However, when using an FET amp, set to 100%.

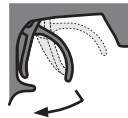

2 Throttle (brake side/reverse side) adjustment

Move the throttle trigger fully to the brake side and use the (+) or (-) buttons to adjust the throttle angle. However, when using an ESC, set to 100%.



3 When ending, return to the MENU1 screen by pressing the (JOG) button.

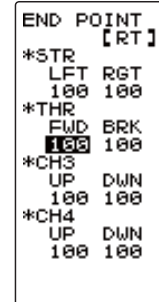
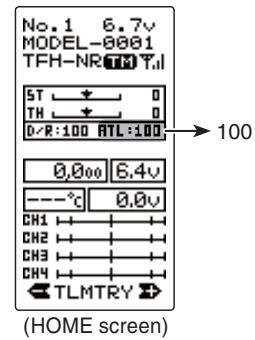

Adjust button

- Use the (+) and (-) buttons to make adjustments.
- Return to the initial value "100" by pressing the (+) and (-) buttons simultaneously for about 1 second.

Throttle EPA

THR FWD :0~120
 THR BRK :0~120
 Initial value :100

3rd & 4th channel servo (END POINT) adjustment

1 3rd/4th channel servo (up side) adjustment

Select the setting item "CH3 or CH4 UP" by the (JOG) button up or down operation, and set the 3rd or 4th channel dial fully to the up side (+ side) and use the (+) or (-) buttons to adjust the servo angle.

2 3rd/4th channel servo (down side) adjustment

Select the setting item "CH3 or CH4 DWN" by the (JOG) button up or down operation, and set the 3rd or 4th channel dial fully to the up side (- side) and use the (+) or (-) buttons to adjust the servo angle.

3 When ending, return to the MENU1 screen by pressing the (JOG) button.

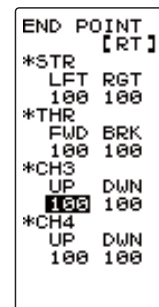

Adjust button

- Adjust with the (+) and (-) buttons.
- Return to the initial value "100" by pressing the (+) and (-) buttons simultaneously for about 1 second.

3rd & 4th channel EPA

CH3/CH4 UP :0~120
 CH3/CH4 DWN :0~120
 Initial value :100

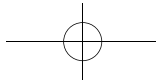

Fail Safe Function "FAIL SAFE"

(All channel)

Fail Safe Mode (F/S)

This function moves each servo to a preset position when the receiver cannot receive the signals from the transmitter for some reason.

-When the condition set at "FHSS" is Rx type (P29), fail safe (F/S) can be set only for throttle (TH). Other channels are set to the normal mode.

-The fail safe data is transferred from the transmitter to the receiver 10 seconds after the transmitter power was turned on. The data is transferred every 5 seconds after that. Be careful because normally the transmitter power is turned on first and the receiver power is turned on next and the data is transferred for approximately 10 seconds after the receiver power is turned on.

-For gasoline engine cars, for safety we recommend that this fail safe function be used to set the throttle channel in the direction in which the brakes are applied.

Hold mode (HOLD)

This function holds the receiver in its position immediately before reception was lost. It is the T-FHSS typ (R304SB...etc) and the S-FHSS type (R2104GF...etc) receiver only function. When the receiver used is the R603GF/R2004GF and other FHSS type, this function cannot be used because the receiver type is set to "FHSS" by Rx type setting

Off mode (OFF)

This function stops output of signals to the servos and places the servos into the free state when the receiver cannot receive.

The F/S, HOLD, and OFF modes are automatically reset when signals from the transmitter can be received again.

Battery fail safe function (BFS)

If the receiver battery voltage drops below a certain value when this function is enabled, the throttle servo moves to the position set by fail safe function. When the battery voltage recovers, the battery fail safe function is automatically reset.

-This function cannot be used when the throttle (TH) is not set to fail safe (F/S).

-This function is for the T-FHSS typ (R304SB...etc) and the S-FHSS type (R2104GF...etc) receiver only. It cannot be used with the R603GF and R2004FG and other FHSS type.

Display to "FAIL SAFE" screen by the following method:

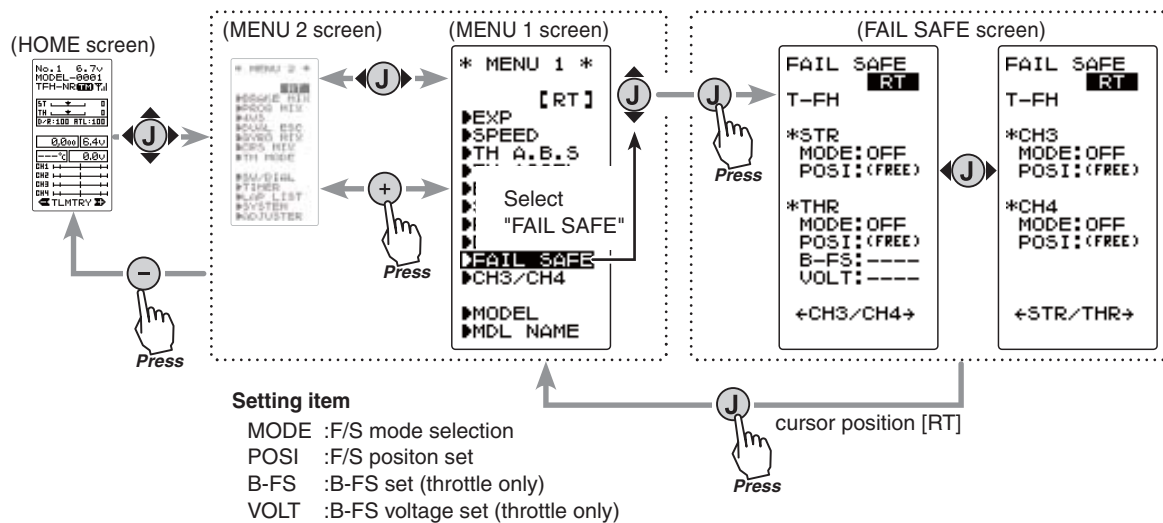

Function

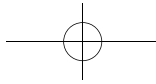

Fail safe mode selection

(Preparation)

- Select the channels "MODE" to be set by the (JOG) button up, down, left, or right operation.

1 (Mode selection)

Select the mode by (+) or (-) button.

(Each channel can be individually set.)

2

When ending, move the cursor to [RT] by the (JOG) button, and return to the MENU1 screen by pressing the (JOG) button. When setting fail safe, set the servo position by the following method.

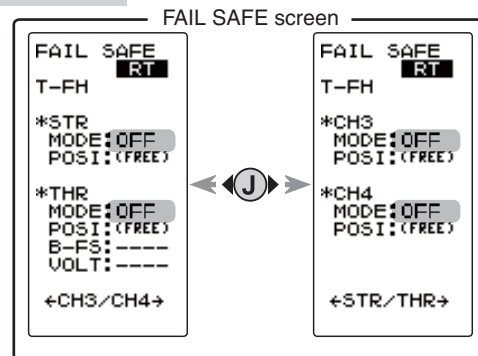

F/S mode

OFF, HOLD, F/S

F/S mode selection

- Select with the (+) or (-) buttons.

F/S position setup button

- The (JOG) buttons is pressed for about 1 second.

Fail safe function setup

1 (Servo position setup)

When the fail safe function operates, select the setting item "POSI" by the (JOG) button. The steering wheel, the throttle trigger or 3rd, 4th channel dial remains in the desired operation position. When the (JOG) button is pressed for about 1 second, the servo position is displayed and you can confirm that the function was set.

(Each channel can be set similarly.)

2

When ending, move the cursor to [RT] by the (JOG) button, and return to the MENU1 screen by pressing the (JOG) button.

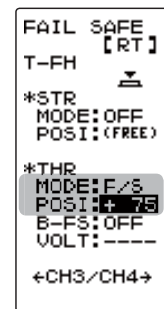

Battery fail safe function ON/OFF (T-FHSS/ S-FHSS)

(Preparation)

- Select the setting item by the (JOG) button. For Battery F/S function ON/OFF, select "OFF" or "ACT" of "B-FS".

For voltage setting, select RX**v. (The T-FHSS system only.)

The S-FHSS system is fixed at 3.8v.

1 (Battery fail safe function ACT/OFF)

BATT-F/S function ACT/OFF and voltage setting which activates the B-F/S function can be switched by (+) or (-) button.

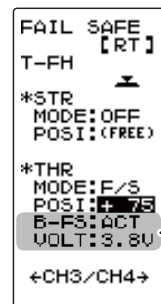

Battery fail safe function

OFF, ACT

Initial value: OFF

B-F/S Voltage

3.8, 4.0, 4.2, 4.4, 4.6, 4.8, 5.0, 5.3, 5.6, 5.9, 6.2, 6.5, 6.8, 7.1, 7.4(V)

Initial value 3.8v

Example:

Ni-MH /Ni-Cd 4cell---3.8V

Ni-MH /Ni-Cd 6cell---4.4V

LiFe 2cell---4.8V

Li-Po 2cell---5.6V

2

When ending, move the cursor to [RT] by the (JOG) button, and return to the MENU1 screen by pressing the (JOG) button.

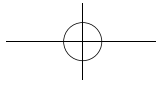

Exponential Adjustment "EXP" (Steering/Throttle system)

This function is used to change the sensitivity of the servo around the neutral position. Display to "EXP" screen by the following method:

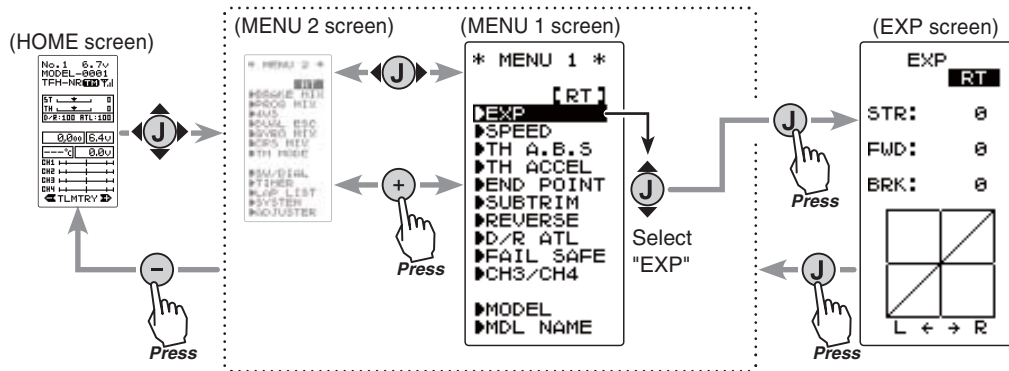

Setting item

STR :Steering
FWD :Throttle forward side
BRK :Throttle brake/ reverse side

STR (Steering EXP)

This function is used to change the sensitivity of the steering servo and around the neutral position. It has no effect on the maximum servo travel.

Racers Tip

When the setting is not determined, or the characteristics of the model are unknown, start with 0%. (When EXP is set to 0%, servo movement is linear.)

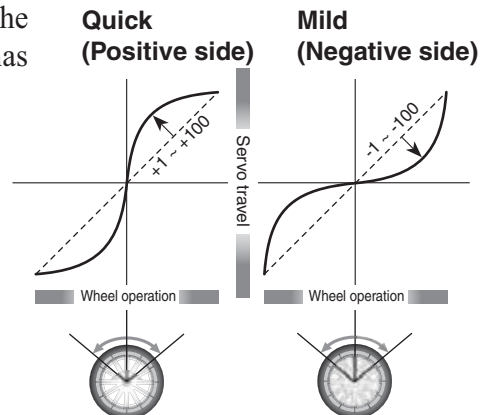

Steering EXP adjustment

(Preparation)

- On the EXP screen, Select the setting item "STR" by the (JOG) button.

- 1 When you want to quicken steering operation, use the (+) button to adjust the + side. When you want to make steering operation milder, use the (-) button to adjust the - side.

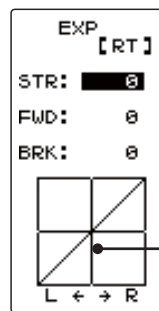

Adjustment range

-100~0~+100

Adjust button

- Adjust with the (+) and (-) buttons.
- Return to the initial value "0" by pressing the (+) and (-) buttons simultaneously for about 1 second.

Vertical cursor moves in step with steering wheel operation.

- 2 When ending, return to the MENU1 screen by pressing the (JOG) button.

Function

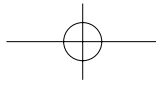

FWD (Throttle Forward SideEXP)/ BRK (Throttle Brake Side EXP)

This function makes the throttle forward side and brake side direction servo operation quicker or milder. It has no effect on the servo maximum operation amount.

Advice

When the course conditions are good and the surface has good grip, set each curve to the + side (quick side). When the road surface is slippery and the drive wheels do not grip it, set each curve to the - minus (mild) side.

Throttle forward side EXP adjustment

(Preparation)

- On the EXP screen make the following adjustments:

1 Select the setting item "FWD" by the (JOG) button up or down operation.

Use the p(+) button to adjust for a faster throttle response or use the (-) button for a slower or milder throttle response.

Adjustment range

-100 ~ 0 ~ +100%

Adjust button

Adjust with the (+) and (-) buttons.

- Return to the initial value "0" by pressing the (+) and (-) buttons simultaneously for about 1 second.

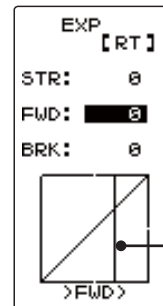
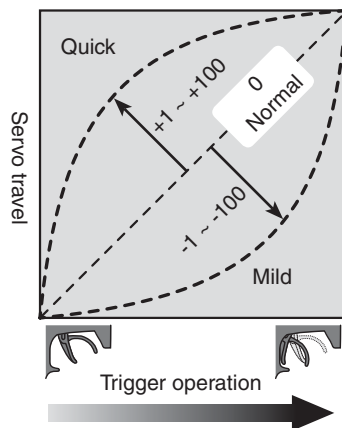

Vertical cursor moves in step with throttle trigger operation.

2 When ending, return to the MENU1 screen by pressing the (JOG) button.

Function

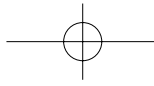

Throttle brake side EXP adjustment

(Preparation)

- On the EXP screen make the following adjustments:

1 Select the setting item "BRK" by the (JOG) button up or down operation.

Use the (+) button to adjust for a faster throttle response or use the (-) button for a slower or milder throttle response.

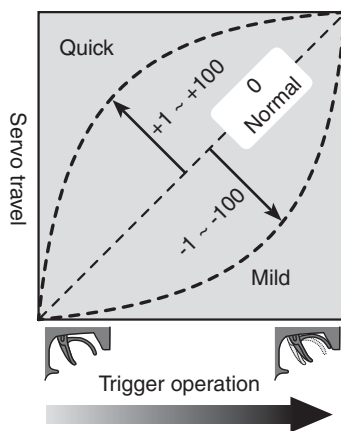

Adjustment range

-100 ~ 0 ~ +100%

Adjust button

Adjust with the (+) and (-) buttons.

- Return to the initial value "0" by pressing the (+) and (-) buttons simultaneously for about 1 second.

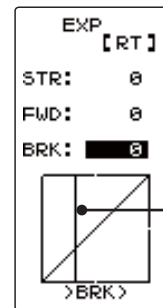

Vertical cursor moves in step with throttle trigger operation.

2 When ending, return to the MENU1 screen by pressing the (JOG) button.

Dial / Trim Setting

The steering and throttle EXP adjustment (RATE) can be controlled with digital dial or digital trim. With the function select switch dial function. (See page 65)

Function

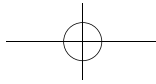

Servo Speed "SPEED"

(Steering system)

This function is used to change the servo speed.
Display to "SPEED" screen by the following method:

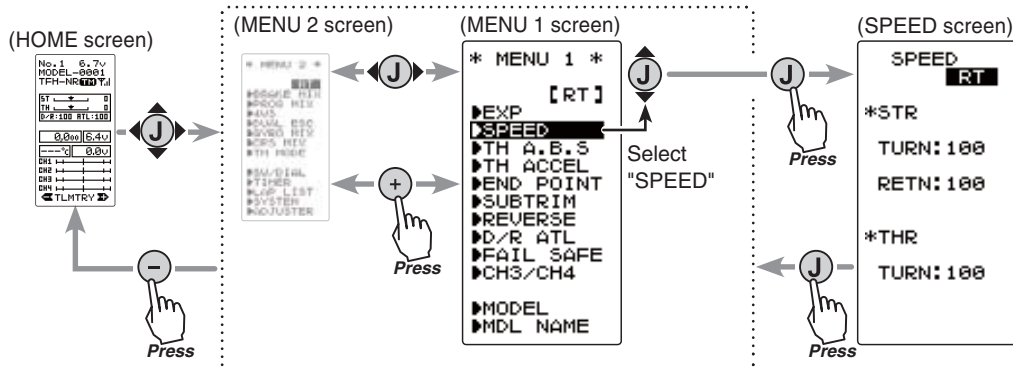

Setting item
 STR TURN :Steering turn side
 STR RETN :Steering return side
 THR TURN :Throttle turn side

STR (Steering Speed)

Quick steering operation will cause momentary understeering, loss of speed, or spinning. This function is effective in such cases.

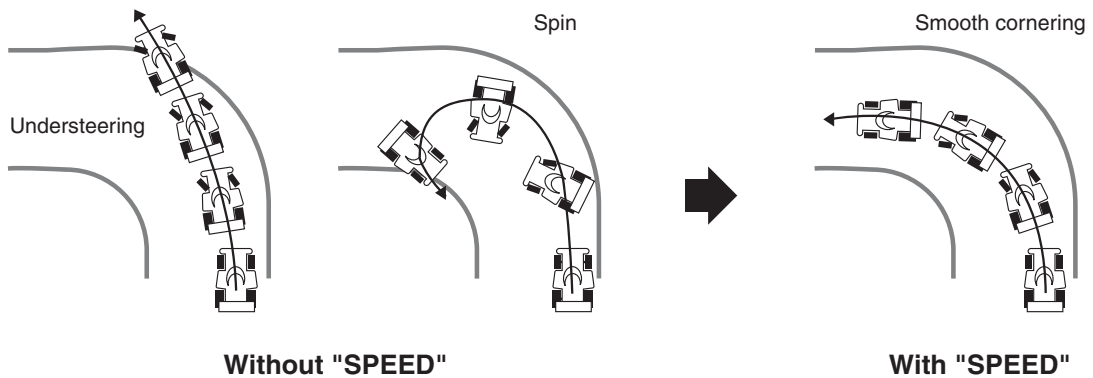

Function

Operation

- This function limits the maximum speed of the steering servo. (Delay function)
- The steering speed when the steering wheel is operated (TURN direction) and returned (RETN direction) can be independently set.
- If the steering wheel is turned slower than the set speed, the steering servo is not affected.

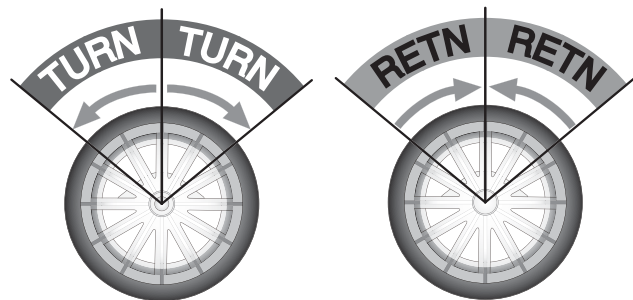

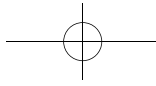

Steering Speed adjustment

(Preparation)

- On the SPEED screen make the following adjustments:

1 "TURN" direction adjustment

On the SPEED screen, Select the setting item STR "TURN" by the (JOG) button up or down operation and use the (+) or (-) buttons to adjust the delay amount.

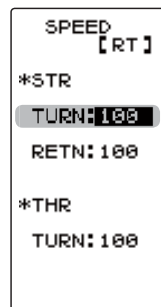
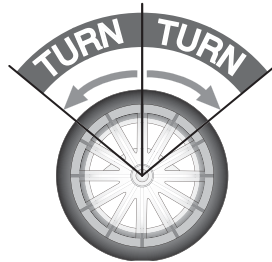

Adjustment range

1~100% (each direction)
At 100%, there is no delay.
1% 100%
←
Servo operation is delayed.

Adjust button

- Adjust with the (+) and (-) buttons.
- Return to the initial value "100" by pressing the (+) and (-) buttons simultaneously for about 1 second.

2 "RETN" direction adjustment

Select the setting item STR "RETN" by the (JOG) button up or down operation and use the (+) or (-) buttons to adjust the delay amount.

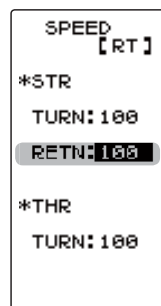
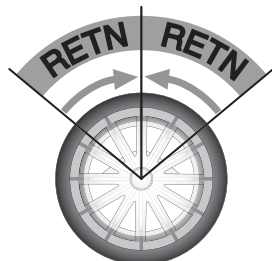

Adjustment range

1~100% (each direction)
At 100%, there is no delay.
1% 100%
←
Servo operation is delayed.

Adjust button

- Adjust with the (+) and (-) buttons.
- Return to the initial value "100" by pressing the (+) and (-) buttons simultaneously for about 1 second.

3 When ending, return to the MENU1 screen by pressing the (JOG) button.

Setting example (Steering servo: BLS451 / BLS351) ... (Setting criteria)

- Onroad TURN side: Approx. 50~80% RETURN side: Approx. 60~100%
- Offroad TURN side: Approx. 70~100% RETURN side: Approx. 80~100%

Dial / Trim Setting

The steering speed adjustment "TURN" and "RETN" can be controlled with digital dial or digital trim. With the function select switch dial function. (See page 65)

Function

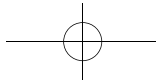

THR (Throttle Speed)

Sudden throttle trigger operation on a slippery road only causes the wheels to spin and the vehicle cannot accelerate smoothly. Setting the throttle speed function reduces wasteful battery consumption while at the same time permitting smooth, enjoyable operation.



Operation

-Throttle servo (ESC) operation is delayed so that the drive wheels will not spin even if the throttle trigger is operated more than necessary.

This delay function is not performed when the throttle trigger is returned and at brake operation.

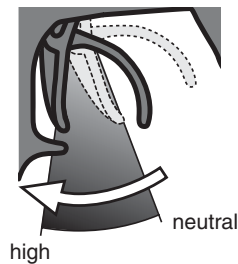

Throttle Speed adjustment

(Preparation)

- On the SPEED screen make the following adjustments:

1 (Delay adjustment)

On the SPEED screen, Select the setting item THR "TURN" by the (JOG) button up or down operation and use the (+) or (-) buttons to adjust the delay amount.

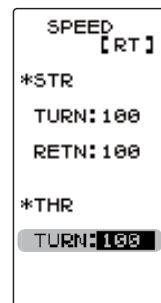

Adjustment range

1~100%

At 100%, there is no delay.

1% 100%

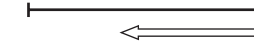

Servo operation is delayed.

Adjust button

- Adjust with the (+) and (-) buttons.

- Return to the initial value "100" by pressing the (+) and (-) buttons simultaneously for about 1 second.

2 When ending, return to the MENU1 screen by pressing the (JOG) button.

Function

Dial / Trim Setting

The throttle speed adjustment can be controlled with digital dial or digital trim. With the function select switch dial function. (See page 65)

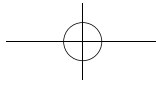

Throttle Acceleration "TH ACCEL" (Throttle system)

The servo will jump to the input position at its maximum possible speed. Unlike exponential, which adjusts the whole throttle movement into a curve, throttle acceleration simply "jumps" away from neutral and then leaves the remaining response linear.

Operation

- Operation near the throttle trigger neutral position becomes a sharp rise.
- The forward and brake sides can be set separately.
- When the brake mixing function (p.72) is set, the CH3/CH4 brake can also be set.

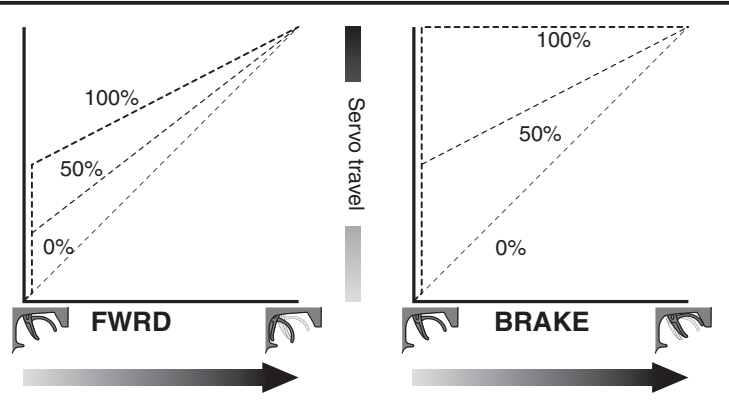

Set value

The standard value (100% point) of this setup affects the operation amount set by throttle EPA function.

Convenient usage method

For gasoline engine cars, the linkage must have a clearance because one servo controls the engine carburetor and brake. Thus, there is a noticeable time delay at both the forward and brake sides. Sharp response comparable to that of electric motor cars is obtained by reducing this clearance at the transmitter side.

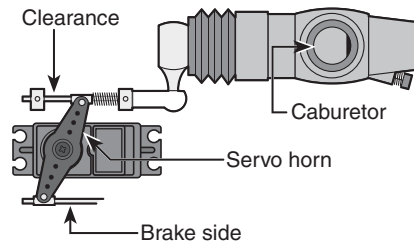

Display to "TH ACCEL" screen by the following method:

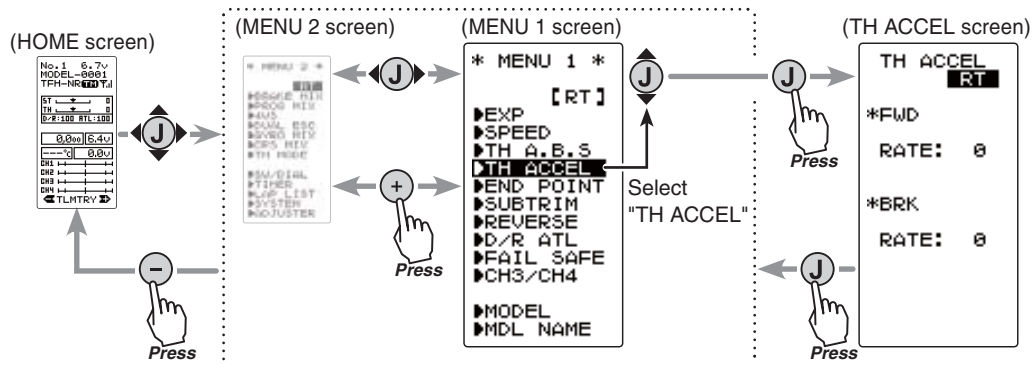

Setup item

- FWR RATE :Forward side acceleration
- BRA RATE :Brake side acceleration

Function

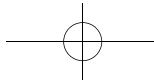

Throttle acceleration adjustment

(Preparation)

- On the TH ACCEL screen make the following adjustments:

1 (Forward acceleration amount adjustment)

Select the setting item FWD "RATE" by the (JOG) button up or down operation and use the (+) and (-) buttons to adjust the acceleration amount.

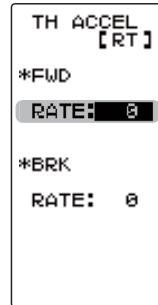

"0" :No acceleration

"100" :Maximum acceleration (Approximately 1/2 of the forward side throttle angle)

Forward acceleration amount (FWD)

0~100

Initial value: 0

Adjust button

Adjust with the (+) and (-) buttons.

- Return to the initial value "0" by pressing the (+) and (-) buttons simultaneously for about 1 second.

2 (Brake side acceleration amount adjustment)

Select the setting item BRK "RATE" by the (JOG) button up or down operation and use the (+) and (-) buttons to adjust the acceleration amount.

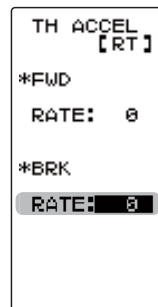

"0" :No acceleration

"100" :Maximum acceleration (Brake side maximum throttle angle)

Brake side acceleration amount (BRK)

0~100

Initial value: 0

Adjust button

Adjust with the (+) and (-) buttons.

- Return to the initial value "0" by pressing the (+) and (-) buttons simultaneously for about 1 second.

4 When ending, return to the MENU1 screen by pressing the (JOG) button.

Dial / Trim Setting

The throttle acceleration adjustment amount (FWD), (BRK) can be controlled with digital dial or digital trim. With the function select switch dial function. (See page 65)

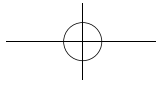

A.B.S. Function "TH A.B.S"

(Throttle system)

When the brakes are applied while cornering with a 4 Wheel Drive or other type of vehicle, understeer may occur. The generation of understeer can be eliminated and corners can be smoothly cleared by using this function.

Operation

- When the brakes are applied, the throttle servo will pulse intermittently. This will have the same effect as pumping the brakes in a full size car.
- The brake return amount, delay amount, pulse cycle, and brake duty can be adjusted.

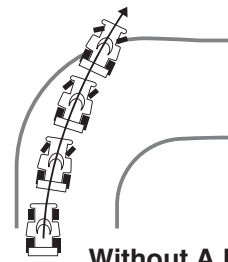

Without A.B.S.

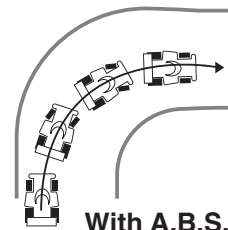

With A.B.S.

Operation display

During ABS operation, the LED blinks.

Display "TH A.B.S" screen by the following method:

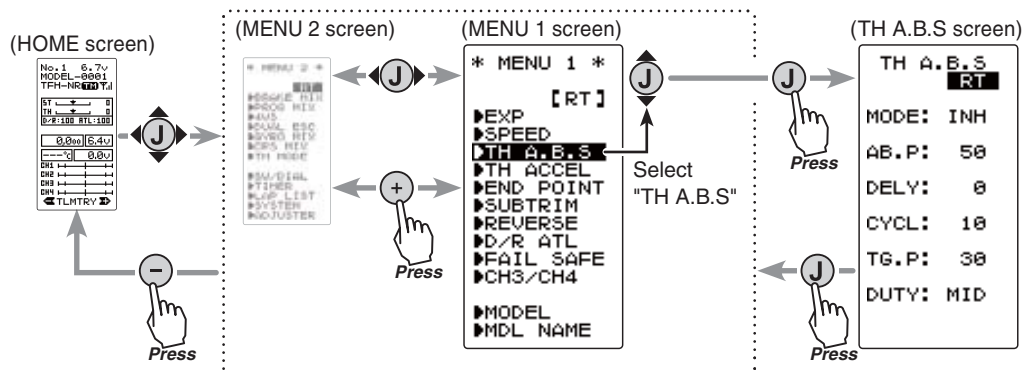

Setup items

MODE	: Function ON/Off	CYCL	: Cycle speed
AB.P	: Brake return amount	TG.P	: Trigger point
DELY	: Delay amount	DUTY	: Cycle duty ratio

- AB.P : Amount of brake return

Sets the rate at which the servo returns versus trigger operation for brake release. When set to 0%, the ABS function is not performed. When set to 50%, the servo returns 50% (1/2) of the trigger operation amount and when set to 100%, the servo returns to the neutral position.

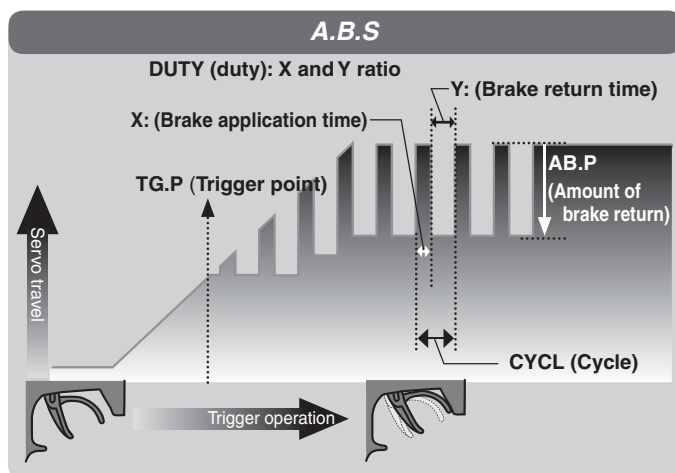

Function

A.B.S. Function "TH A.B.S"

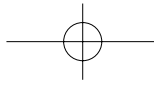

- DELY : Delay

Sets the delay from brake operation to ABS operation. When set to 0%, the ABS function is activated without any delay. At 50%, the ABS function is activated after a delay of approximately 1 second and at 100%, the ABS function is activated after a delay of approximately 2 seconds.

- CYCL : Cycle speed

Sets the pulse speed (cycle). The smaller the set value, the faster the pulse cycle.

- TG.P : Trigger point

Sets the trigger point at which the ABS function begins to operate at brake operation.

- DUTY : Cycle duty ratio

Sets the proportion of the time the brakes are applied and the time the brakes are released by pulse operation. The ratio can be set to HIGH, MID or LOW.

- MODE : Function ON/OFF

ABS function ON/OFF setting. When using the ABS function, set to "ACT(ON)".

A.B.S function adjustment

1 (Function ON/OFF)

Select the setting item "MODE" by the (JOG) button up or down operation. Set the function to the active state by pressing the (+) or (-) button.

- "INH(OFF)" :Function OFF
- "ACT(ON)" :Function ON
- "ACT(OFF)" :Switch OFF when setting switches

Select button

- Select with the (+) or (-) buttons.

Function ON/OFF (MODE)

INH(OFF), ACT(ON,OFF)

2 (Brake return amount adjustment)

Select the setting item "AB.P" by the (JOG) button up or down operation. Use the (+) or (-) button to adjust the return amount.

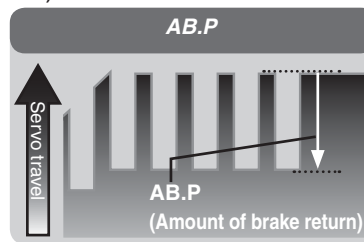

- "0" :No return
- "50" :Return to the 50% position of the brake operation amount
- "100" :Return to the neutral position.

Brake return amount (AB.P)

0 ~ 50 ~ 100
Initial value: 50

- Brake return amount (AB.P) is influenced by the "EXP" rate on the brake side.

Adjustment buttons

- Use the (+) and (-) buttons to make adjustments.
- Return to the initial value by pressing the (+) and (-) buttons simultaneously (approx. 1 sec).

3 (Delay amount setup)

Select the setting item "DELY" by the (JOG) button up or down operation. Use the (+) or (-) button to adjust the delay amount.

- "0" :A.B.S. function performed without any delay
- "50" :A.B.S. function performed after an approximate 1 sec delay.
- "100" :A.B.S. function performed after an approximate 2 secs delay.

Delay amount (DELY)

0 ~ 100
Initial value: 0

Adjustment buttons

- Use the (+) and (-) buttons to make adjustments.
- Return to the initial value by pressing the (+) and (-) buttons simultaneously (approx. 1 sec).

Function