

FMT-03

Futaba Advanced Spread Spectrum Technology
Extended System Telemetry



FASST Extended System Telemetry



INSTRUCTION MANUAL

For model

1M23Z04404

Futaba® *Digital Proportional R/C System*

TABLE OF CONTENTS

INTRODUCTION.....	4	•Link procedure	33
•Support and Service	4	•Range testing your R/C system.....	35
•Application, Export, and Modification	4	•Channels connection by multicopter type	36
•Definitions of Symbols.....	7		
•Safety Precautions (do not operate without reading)	7		
<hr/>			
BEFORE USE	11	FUNCTIONS OF SYSTEM MENU	37
•Features of FMT-03	11	Display	38
•Contents and technical specifications	12	System Timer	39
•Accessories.....	13	User Name.....	40
•Transmitter controls	14	Sound.....	41
Transmitter's antenna.....	15	H/W Setting.....	42
Switch (SA-SH).....	17	Information	44
Volume (DA-DD)	17	Range Check	45
Monitor LED	17	S.BUS Servo	46
Edit dial.....	17		
Home/Exit, U.menu/Mon. Button	19	FUNCTIONS OF LINKAGE MENU	49
Maintenance example of a transmitter	19	Linkage Menu functions table	49
Micro SD Card	20	Servo Monitor.....	50
Connector.....	21	Model Select.....	51
Installation and removal of the battery.....	22	Model Type (This function isn't used).....	53
•Receiver FMR-03.....	23	System Type	54
•Telemetry sensor	24	Function	56
•S.BUS2 servo	24	Sub-Trim	58
•Receiver's antenna installation.....	25	Servo Reverse	59
•Mounting the servo.....	26	Fail Safe.....	60
•Safety precautions when installing servos... 26		End Point	61
•S.BUS2 Devicesetting	27	Throttle Cut	62
		Idle Down	63
<hr/>			
BASIC OPERATION	28	Timer	64
•Battery Charging	28	T1-T6 Setting.....	66
•How to turn transmitter power ON/OFF 29		Multiprop	67
•Registration of the user's name	29	Function Name	68
•Home screen	30	Telemetry.....	69
•User menu.....	31	Telemetry:receiver [battery]	70
•Key lock	32	Telemetry:receiver [EXT-batt].....	71
		Telemetry:temperature	72
		Telemetry:rpm sensor	73
		Telemetry:altitude	74
		Telemetry:altitude [variometer].....	75
		Telemetry:voltage [battery].....	76
		Telemetry:voltage [EXT-volt].....	77

TABLE OF CONTENTS

Telemetry:GPS [distance].....	78
Telemetry:GPS [speed]	80
Telemetry:GPS [altitude,variometer,position]	81
Telemetry:Servo sensor [current] [temperature] [angle].....	82
Telemetry:Current sensor [current] [voltage] [capacity].....	83
Sensor	84
Sensor:reload	85
Sensor:register	85
Sensor:change slot.....	86
Tele. Setting.....	87
Warning.....	88
Trainer.....	89
Stick Alarm	92
Data Reset	93
<hr/>	
FUNCTIONS OF MODEL MENU	94
•Common Functions	94
Condition Select	95
AFR	97
Dual Rate	98
Program Mix.....	99
Gyro.....	103
<hr/>	
DATA.....	104
•Common Operations used in function setup screen.....	104
•Updating	112

Reference

FMT-03 is equipped with a stick of multi-copter exclusive use. Therefore it's unsuitable for use of an airplane, a glider and a helicopter.

Reference.....	113
•Airplane/Glider Functions	114
Servo connection by airplane/glider type...	116
AIL Differential	120
Flap Setting.....	121
AIL to Camber FLP	122
AIL to Brake FLP.....	123
AIL to RUD.....	124
Airbrake to ELE.....	125
RUD to AIL.....	127
Camber Mix.....	128
ELE to Camber	130
Camber FLP to ELE	131
Butterfly	132
Trim Mix 1/2	134
Airbrake (Airplane only).....	136
Gyro (for GYA type gyro).....	138
V-tail	140
Ailevator.....	141
Winglet	142
Motor.....	143
Acceleration	144
RUD to ELE.....	145
Snap Roll (Airplane only).....	146
•Helicopter Functions	147
Servo connection by helicopter type.....	148
PIT Curve	149
PIT trim.....	150
THR Curve	152
Throttle hover trim	153
Acceleration	155
THR Hold.....	156
Swash Mix.....	157
Throttle Mix.....	158
PIT to Needle	159
PIT to RUD (Revolution mix)	160
Gyro (for GY type gyro)	161
Governor	162
Cond. Hold.....	164
Swash Ring (Linkage Menu).....	165
Swash (Linkage Menu)	166

INTRODUCTION

Thank you for purchasing a Futaba® FASSTest-2.4GHz* FMT-03 series digital proportional R/C system. In order for you to make the best use of your system and to fly safely, please read this manual carefully.

*FASSTest: Futaba Advanced Spread Spectrum Technology extend system telemetry

Due to unforeseen changes in production procedures, the information contained in this manual is subject to change without notice.

FOR SUPPORT : (PROGRAMMING AND USER QUESTIONS)

FUTABA Corporation of America

101 Electronics Boulevard, Huntsville, Alabama 35824, U.S.A

Fax: 1-256-461-1059

Phone: 1-256-461-9399

OUTSIDE NORTH AMERICA

Please contact your Futaba importer in your region of the world to assist you with any questions, problems or service needs.

Please recognize that all information in this manual, and all support availability, is based upon the systems sold in North America only. Products purchased elsewhere may vary. Always contact your region's support center for assistance.

Application, Export, and Modification

1. This product may be used for unmanned aerial vehicle use. It is not intended for use in any application other than the control of models for unmanned aerial vehicle. The product is subject to regulations of the Ministry of Radio/Telecommunications and is restricted under Japanese law to such purposes.

2. Exportation precautions:

(a) When this product is exported from the country of manufacture, its use is to be approved by the laws governing the country of destination which govern devices that emit radio frequencies. If this product is then re-exported to other countries, it may be subject to restrictions on such export. Prior approval of the appropriate government authorities may be required. If you have purchased this product from an exporter outside your country, and not the authorized Futaba distributor in your country, please contact the seller immediately to determine if such export regulations have been met.

(b) Use of this product with other than models may be restricted by Export and Trade Control Regulations, and an application for export approval must be submitted. This equipment must not be utilized to operate equipment other than radio controlled models.

3. Modification, adjustment, and replacement of parts: Futaba is not responsible for unauthorized modification, adjustment, and replacement of parts on this product. Any such changes may void the warranty.

Compliance Information Statement

This device complies with part 15 of the FCC Rules. Operation is subject to the following three conditions:

(1) This device may not cause harmful interference, and (2) This device must accept any interference received, including interference that may cause undesired operation.

(3) RF Radiation Exposure Statement (For FMT-03)

This equipment complies with FCC radiation exposure limits set forth for an uncontrolled environment.

This transmitter must not be co-located or operating in conjunction with any other antenna or transmitter.

RF Radiation Exposure Statement (For FMR-03)

This equipment complies with FCC radiation exposure limits set forth for an uncontrolled environment. This equipment should be installed and operated with minimum distance 20cm between the radiator & your body.

The responsible party for the compliance of this device is:

FUTABA Corporation of America

101 Electronics Boulevard, Huntsville, Alabama 35824, U.S.A

Fax: 1-256-461-1059

Phone: 1-256-461-9399



The RBRC. SEAL on the nickel-cadmium battery contained in Futaba products indicates that Futaba Corporation is voluntarily participating in an industry-wide program to collect and recycle these batteries at the end of their useful lives, when taken out of service within the United States. The RBRC. program provides a convenient alternative to placing used nickel-cadmium batteries into the trash or municipal waste system, which is illegal in some areas.

(for USA)

You may contact your local recycling center for information on where to return the spent battery. Please call 1-800-8BATTERY for information on NiCd battery recycling in your area. Futaba Corporation involvement in this program is part of its commitment to protecting our environment and conserving natural resources.

*RBRC is a trademark of the Rechargeable Battery Recycling Corporation.

NOTE:

This device complies with Industry Canada license-exempt RSS standard(s). Operation is subject to the following two conditions: (1) this device may not cause interference, and (2) this device must accept any interference, including interference that may cause undesired operation of the device.

This equipment complies with IC radiation exposure limits set forth for an uncontrolled environment. This transmitter must not be co-located or operating in conjunction with any other antenna or transmitter. (For FMT-03)

This equipment complies with IC radiation exposure limits set forth for an uncontrolled environment. This equipment should be installed and operated with minimum distance 20cm between the radiator & your body. (For FMR-03)

French: Cet appareil radio est conforme au CNR-210 d'Industrie Canada. L'utilisation de ce dispositif est autorisée seulement aux deux conditions suivantes : (1) il ne doit pas produire de brouillage, et (2) l'utilisateur du dispositif doit être prêt à accepter tout brouillage radioélectrique reçu, même si ce brouillage est susceptible de compromettre le fonctionnement du dispositif. Cet équipement est conforme aux limites d'exposition aux rayonnements IC établies pour un environnement non contrôlé. Cet émetteur ne doit pas être co-situé ou fonctionner conjointement avec une autre antenne ou émetteur. (For FMT-03)

Cet équipement est conforme aux limites d'exposition aux rayonnements IC établies pour un environnement non contrôlé. Cet équipement doit être installé et utilisé avec un minimum de 20 cm de distance entre la source de rayonnement et votre corps (For FMR-03)

This radio transmitter (identify the device by certification number) has been approved by Industry Canada to operate with the antenna types listed below with the maximum permissible gain indicated. Antenna types not included in this list, having a gain greater than the maximum gain indicated for that type, are strictly prohibited for use with this device.

No.	Name	Gain(Peak)	Remark
1	MEIWX-2102RSAX-2400	2.25dBi	1/2 λ Pencil type antenna

CAUTION:

To assure continued FCC compliance:

Any changes or modifications not expressly approved by the grantee of this device could void the user's authority to operate the equipment.

FLYING SAFETY

⚠ WARNING

To ensure the safety of yourself and others, please observe the following precautions:

Have regular maintenance performed. Although your FMT-03 protects the model memories with non-volatile EEPROM memory (which does not require periodic replacement) and not a battery, the transmitter still should have regular checkups for wear and tear. We recommend sending your system to the Futaba Service Center annually during your non-flying-season for a complete checkup and service.

Battery

Charge the batteries! Always recharge the transmitter and receiver batteries before each flying session. A low battery will soon die potentially, causing loss of control and a crash. When you begin your flying session, reset your FMT-03's built-in timer, and during the session pay attention to the duration of usage.

Stop flying long before your batteries become low on charge. Do not rely on your radio's low battery warning systems, intended only as a precaution, to tell you when to recharge. Always check your transmitter and receiver batteries prior to each flight.

Where to Fly

We recommend that you fly at a recognized model airplane flying field. You can find model clubs and fields by asking your nearest hobby dealer, or in the US by contacting the Academy of Model Aeronautics.

You can also contact the national Academy of Model Aeronautics (AMA), which has more than 2,500 chartered clubs across the country. Through any one of them, instructor training programs and insured newcomer training are available. Contact the AMA at the address or toll-free phone number below.

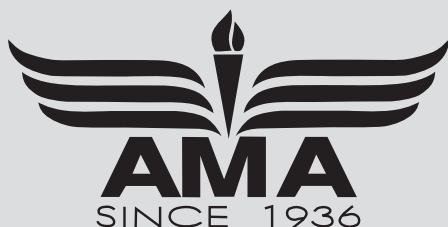

Academy of Model Aeronautics

5161 East Memorial Drive

Muncie, IN 47302

Tele. (800) 435-9262

Fax (765) 289-4248

or via the Internet at <http://www.modelaircraft.org>

Always pay particular attention to the flying field's rules, as well as the presence and location of spectators, the wind direction, and any obstacles on the field. Be very careful flying in areas near power lines, tall buildings, or communication facilities as there may be radio interference in their vicinity.

Precautions

Application, Export, and Modification Precautions.

1. This product is only designed for use with radio control models. Use of the product described in this instruction manual is limited to radio control models.
 2. Export precautions:
 - a) When this product is exported, it cannot be used where prohibited by the laws governing radio waves of the destination country.
 - b) Use of this product with other than models may be restricted by Export and Trade Control Regulations.
 3. Modification, adjustment, and parts replacement
Futaba is not responsible for unauthorized modification, adjustment, or replacement of parts on this product.
- No part of this manual may be reproduced in any form without prior permission.
 - The contents of this manual are subject to change without prior notice.
 - Futaba is not responsible for the use of this product by the customer.
 - Company and product names in this manual are trademarks or registered trademarks of the respective company.

For safe use

Please observe the following precautions to ensure safe use of this product at all times.

Meaning of Special Markings:

The parts of this manual indicated by the following marks require special attention from the standpoint of safety.

⚠ DANGER - Procedures which may lead to dangerous conditions and cause death/serious injury if not carried out properly.

⚠ WARNING - Procedures which may lead to a dangerous condition or cause death or serious injury to the user if not carried out properly, or procedures where the probability of superficial injury or physical damage is high.

⚠ CAUTION - Procedures where the possibility of serious injury to the user is small, but there is a danger of injury, or physical damage, if not carried out properly.

⊘ = Prohibited ⚠ = Mandatory

WARNING: Always keep electrical components away from small children.

Flying Precautions

⚠ WARNING

⊘ **Never grasp the transmitter antenna while flying.**

■ The transmitter output may drop drastically.

⊘ **Always make sure that all transmitter stick movements operate all channels properly in the model prior to flight. Also, make sure that all switches, etc. function properly as well. If there are any difficulties, do not use the system until all inputs are functioning properly.**

⊘ **Never fly in the range check mode.**

■ In the dedicated range test range check mode, the transmitter output range is reduced and may cause a crash.

⊘ **While operating, never touch the transmitter with, or bring the transmitter near, another transmitter, a cellphone, or other wireless devices.**

■ Doing so may cause erroneous operation.

⊘ **Do not point the antenna directly toward the aircraft during flight.**

■ The antenna is directional and the transmitter output is weakest. (The strength of the radio waves is greatest from the sides of the antenna.)

⊘ **Never fly on a rainy day, when the wind is strong, and at night.**

■ Water could lead to failure or improper functionality and poor control of the aircraft which could lead to a crash.

⊘ **Never turn the power switch on and off during flight or while the engine or motor is running.**

■ Operation will become impossible and the aircraft will crash. Even if the power switch is turned on, operation will not begin until transmitter and receiver internal processing is complete.

⊘ **Do not fly when you are physically impaired as it could pose a safety hazard to yourself or others.**

⊘ **Do not touch the engine, motor, or motor controller during and immediately after use.**

■ These items may become hot during use.

⊘ **Do not fly at the following places:**

- Near another radio control flying field.
- Near or above people.
- Near homes, schools, hospitals or other places where people congregate.
- Near high voltage lines, high structures, or communication facilities.

⚠ **For safety, fly so that the aircraft is visible at all times.**

- Flying behind buildings or other large structures will not only cause you to lose sight of the aircraft, but also degrade the RF link performance and cause loss of control.

⚠ **From the standpoint of safety, always set the fail safe function.**

- In particular, normally set the throttle channel to idle.

⚠ **When flying, always return the transmitter setup screen to the Home screen.**

- Erroneous input during flight is extremely dangerous.

⚠ **Always check the remaining capacity of the transmitter and receiver battery before each flying session prior to flight.**

- Low battery capacity will cause loss of control and a crash.

⚠ **Always check operation of each control functions and perform a range test before each flying session. Also, when using the trainer function, check the operation of both the teacher and student transmitter.**

- Even one transmitter setting or aircraft abnormality cause a crash.

⚠ **Before turning on the transmitter:**

1. **Always move the transmitter throttle stick position to the minimum (idle) position.**
2. **Turn on the transmitter first and then the receiver.**

⚠ **When turning off the transmitter's power switch. After the engine or motor has stopped (state in which it will not rotate again):**

1. **Turn off the receiver power switch.**
2. **Then turn off the transmitter power switch.**

- If the power switch is turned on/off in the opposite order, the propeller may rotate unexpectedly and cause a serious injury.

- Also always observe the above order when setting the fail safe function.

- Maximum low throttle: Direction in which the engine or motor runs at the slowest speed or stops.

⚠ **When adjusting the transmitter, stop the engine except when necessary. In the case of a motor, disconnect the wiring and to allow it to continue operation. When doing so, please exercise extreme caution. Ensure that the aircraft is secured and that it will not come into contact with anything or anyone. Ensure that the motor will not rotate prior to making any adjustments.**

- Unexpected high speed rotation of the motor/engine may cause a serious injury.

Battery and Charger Handling Precautions

⚠ **DANGER**

⊘ **Do not recharge a battery that is damaged, deteriorated, leaking electrolyte, or wet.**

⊘ **Do not use the charger in applications other than as intended.**

⊘ **Do not allow the charger or battery to become wet.**

- Do not use the charger when it or your hands are wet. Do not use the charger in humid places.

⊘ **Do not short circuit the battery.**

⊘ **Do not solder or repair, deform, modify, or disassemble the battery and/or battery charger.**

⊘ **Do not drop the battery into a fire or bring it near a fire.**

⊘ **Do not charge and store the battery in direct sunlight or other hot places.**

⊘ **Do not charge the battery if it is covered with any object as it may become very hot.**

⊘ **Do not use the battery in a combustible environment.**

- The gas ignites and causes an explosion or fire.

⚠ **Always charge the battery before each flying session.**

- If the battery goes dead during flight, the aircraft will crash.

⚠ Charge the battery with the dedicated charger supplied with the set.

■ Charging the battery past the specified value may cause a fire, combustion, rupture, or liquid leakage. When quick charging, do not charge the battery above 1C.

■ Do not charge the battery while riding in a vehicle. Vibration will prevent normal charging.

⊘ When using the LiFe battery, do not connect the charger to the balance charge connector and the power connector at the same time.

■ Doing so could cause a fire, combustion, generation of heat, rupture, or liquid leakage.

⚠ WARNING

⊘ Do not touch the charger and battery for any length of time during charging.

■ Doing so may result burns.

⊘ Do not use a charger or battery that has been damaged.

⊘ Do not touch any of the internal components of the charger.

■ Doing so may cause electric shock or a burn.

⊘ If any abnormalities such as smoke or discoloration are noted with either the charger or the battery, remove the battery from the transmitter or charger and disconnect the power cord plug and do not use the charger.

■ Continued use may cause fire, combustion, generation of heat, or rupture.

⊘ Do not subject the battery to impact.

■ Doing so may cause fire, combustion, generation of heat, rupture, or liquid leakage.

⚠ CAUTION

⊘ Do not use the battery with devices other than the corresponding transmitter.

⊘ Do not place heavy objects on top of the battery or charger. Also, do not place the battery or charger in any location where it fall.

■ Doing so may cause damage or injury.

⊘ Do not store or use the battery and charger where it is dusty or humid.

■ Insert the power cord plug into the receptacle only after eliminating the dust.

⊘ After the transmitter has been used for a long time, the battery may become hot. Immediately remove from the transmitter.

■ Not doing so may cause a burn.

⚠ Insert the power cord plug firmly into the receptacle up to its base.

⚠ Always use the charger with the specified power supply voltage.

■ Use the special charger by connecting it to a proper power outlet.

⚠ If the battery liquid should get in your eyes, do not rub your eyes, but immediately wash them with tap water or other clean water and get treated by a doctor.

■ The liquid can cause blindness.

⚠ Use and store the battery and battery charger in a secure location away from children.

■ Doing so may cause electric shock or injury.

⚠ If the battery leaks liquid or generates an abnormal odor, immediately move it to a safe place for disposal.

■ Not doing so may cause combustion.

⚠ If the battery liquid gets on your skin or clothing, immediately flush the area with tap water or other clean water.

■ Consult a doctor. The liquid can cause skin damage.

⚠ After the specified charging time has elapsed, end charging and disconnect the charger from the receptacle.

⚠ When recycling or disposing of the battery, isolate the terminals by covering them with insulating tape.

■ Short circuit of the terminals may cause combustion, generation of heat or rupture.

⊘ Do not charge the battery in extreme temperatures.

■ Doing so will degrade the battery performance. An ambient temperature of 10 °C to 30 °C (50F to 86F) is ideal for charging.

⚠ Unplug the charger when not in use.

⊘ Do not bend or pull the cord unreasonably and do not place heavy objects on the cord.

■ The power cord may be damaged and cause combustion, generation of heat, or electric shock.

Micro SD Card (Commercial Product) Handling Precautions

*Read the instruction manual supplied with the micro SD Card for details.

⚠ WARNING

⊘ Never disassemble or modify the micro SD Card.

⊘ Do not unreasonably bend, drop, scratch or place heavy objects on the micro SD Card.

⊘ If smoke or an abnormal odor emanates from the card, immediately turn off the transmitter power.

⊘ Do not use the Micro SD Card where it may be exposed to water, chemicals, oil, or other fluids.
■ Doing so may cause a fire or electric shock by short circuit.

⚠ CAUTION

⚠ Since the micro SD Card is an electronic device, be careful of static electricity.

■ Static electricity may cause erroneous operation or trouble.

⊘ Do not use the micro SD Card near radio and television sets, audio equipment, motors and other equipment that generate noise.

■ Doing so may cause erroneous operation.

⊘ Do not store the micro SD Card in the following places:

- Where the humidity is high
- Where the temperature difference is severe

- Where it is very dusty
- Where the card will be exposed to shock and vibration
- Near speakers and other magnetic devices

⊘ Do not expose the card to shock and vibration and do not remove the card from the card slot while data is being written or read.

■ The data may be damaged or lost.

•Recorded data

The data recorded on the micro SD Card cannot be compensated regardless of the contents or cause of the trouble or obstruction.

Futaba does not perform data restoration or recovery work.

Storage and Disposal Precautions

⚠ WARNING

⊘ Keep wireless equipment, batteries, aircraft, etc. away from children.

⚠ CAUTION

⊘ Do not store wireless devices in the following places:

- Where it is extremely hot (40 °C [104F] or higher) or cold (-10°C [14F] or lower)
- Where the equipment will be exposed to direct sunlight
- Where the humidity is high
- Where vibration is prevalent
- Where it is very dusty

- Where the device may be exposed to steam and heat

⚠ When the device will not be used for a long time, remove the battery from the transmitter and aircraft and store them in a dry place where the temperature is between 0 and 30°C [32F and 86F].

■ Left standing 'as is' may will cause battery deterioration, liquid leakage, etc.

Other Precautions

⚠ CAUTION

⊘ Do not directly expose plastic parts to fuel, oil, exhaust gas, etc.

■ If left in such an environment, the plastic may be attacked and damaged.

■ Since the metal parts of the case may corrode, always keep them clean.

⚠ Always use genuine Futaba products such as transmitter, receiver, servo, FET amplifier, battery, etc.

■ Futaba is not responsible for damage sustained by combination with other than Futaba Genuine Parts. Use the parts specified in the instruction manual and catalog.

⊘ This product SHOULD NOT been used for the devices that is directly related to human life and/or harmful devices for human body such as below applications.

- (1) Medical Devices
- (2) Aerospace/Aviation Related Devices
- (3) Nucleated Devices e.t.c.

BEFORE USE

Features

FASSTest system

The FMT-03 transmitter has adopted the newly developed bidirectional communication system "FASSTest". Data from the receiver can be checked in your transmitter. FASSTest is a maximum 18channels (linear 16 channels + switch 2 channels) 2.4GHz dedicated system.

Waterproof:IP-64

The FMT-03 transmitter and FMR-03 receiver are waterproofing (IP-64).

S.BUS/S.BUS2 system

By using the S.BUS/S.BUS2 system multiple servos, gyros and telemetry sensors are easily installed with a minimum amount of cables.

LiFe battery

FMT-03 is operated by a 6.6V/2,100mAh Lithium Ferrite battery.

Micro SD card (Secure Digital memory card) (Not included)

Model data can be saved to a micro SD card (SD:32MB-2GB SDHC:4GB-32GB). When FMT-03 transmitter software files are released, the software can be updated by using a micro SD card update.

Data input

Large graphic LCD and Edit dial substantially improve ease of setup.

Edit button

Edit dial and three edit buttons are provided, and the operating screen can be immediately "Returned" to the HOME screen during operation. Setting operation can be performed easily by combining this button with a Edit dial.

Vibration function

Selects a function that alerts the operator to various alarms by vibrating the transmitter in addition to sounding a buzzer.

Contents and Technical Specifications

(Specifications and ratings are subject to change without notice.)

Your FMT-03 includes the following components:

- FMT-03 Transmitter
- FMR-03 Receiver
- FT2F2100BV2 LiFe battery & charger

*The set contents depend on the type of set.

Transmitter FMT-03

(2-stick, 18-channel, FASSTest-2.4GHz system)

Transmitting frequency: 2.4GHz band

System: FASSTest 18CH, FASSTest 12CH switchable

Power supply: 6.6V FT2F2100BV2 LiFe battery

Receiver FMR-03

(FASSTest-2.4G system, dual antenna diversity, S.BUS/S.BUS2 system)

Power requirement: 3.7V~7.4V battery or regulated output from ESC, etc. (*1)

Size: 0.92 x 1.36 x 0.42 in. (23.4 x 34.6 x 10.6 mm)

Weight: 0.11 oz. (3g)

(*1) When using an ESC make sure that it is capable of your applications current draw.

Note: The battery in the FMT-03 transmitter is not connected to the battery connector at initial. Please connect the battery connector before use.

The following additional accessories are available from your dealer. Refer to a Futaba catalog for more information:

- FT2F2100BV2 transmitter battery pack - the (2,100mAh) transmitter LiFe battery pack may be easily exchanged with a fresh one to provide enough capacity for extended flying sessions.
- Trainer cord - the optional training cord may be used to help a beginning pilot learn to fly easily by placing the instructor on a separate transmitter. Note: FMT-03 is connected by an exclusive trainer code by FMT-03 fellow. It isn't possible to connect with a transmitter of the different model.
- Servos - FMR-03 can use only futaba S.BUS2 servos.
- Telemetry sensor - please purchase an optional sensor, in order to utilize bidirectional communication system and to acquire the information from a model high up in the sky.
[Temperature sensor : SBS-01T/TE] [Altitude sensor : SBS-01A] [RPM sensor magnet type : SBS-01RM][RPM sensor optical type : SBS-01RO] [RPM sensor brushless motor type : SBS-01RO] [GPS sensor : SBS-01G] [Voltage sensor : SBS-01V] [S.BUS servo sensor : SBS-01S] [Current sensor : SBS-01C]
- Y-harnesses, servo extensions, hub,etc - Genuine Futaba extensions and Y-harnesses, including a heavy-duty version with heavier wire, are available to aid in your larger model and other installations.
- Receivers - various models of Futaba receivers may be purchased for use in other models. (Receivers for FASSTest types are available.)

Transmitter controls

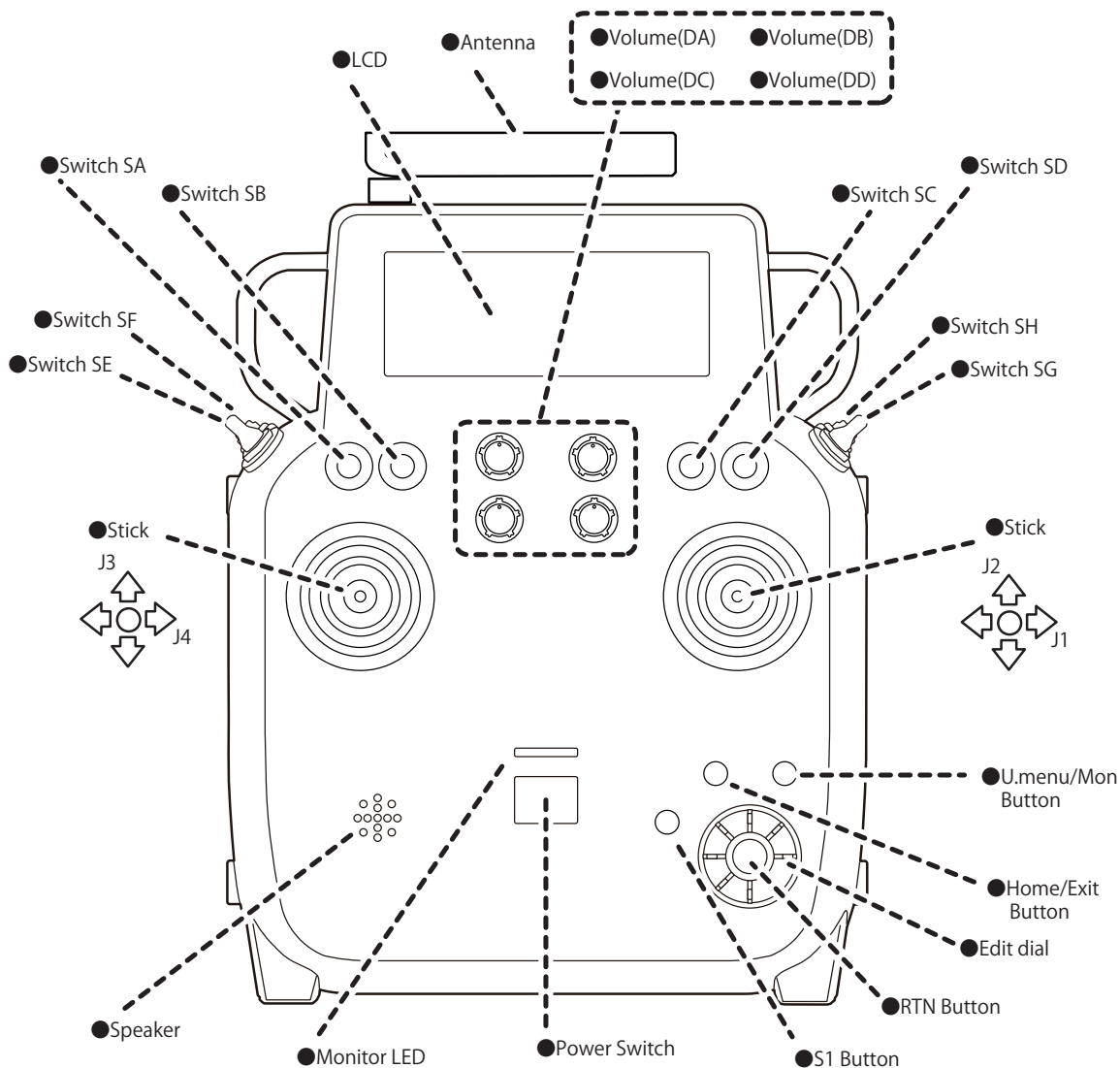

⚠ CAUTION

❗ This transmitter is a self neutral stick. A throttle stick of a transmitter for R/C hobbies of normality is a ratchet-type. Notice should be taken of this difference. When you release your hold, it becomes middle-speed, so be careful.

Transmitter's Antenna:

As with all radio frequency transmissions, the strongest area of signal transmission is from the sides of the transmitter's antenna. As such, the antenna should not be pointed directly at the model. If your flying style creates this situation, easily move the antenna to correct this situation.

• Rotating antenna

The antenna can be rotated 360 degrees and angled 90 degrees. Forcing the antenna further than this can damage it. When making an antenna rotate, be careful so that fixing screw doesn't loosen.

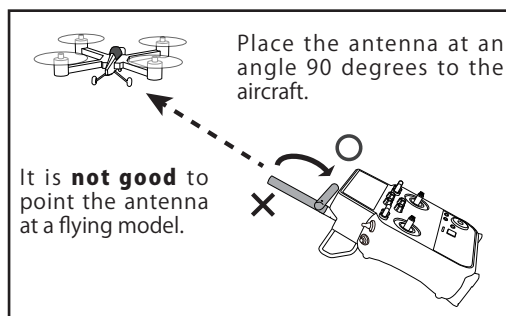
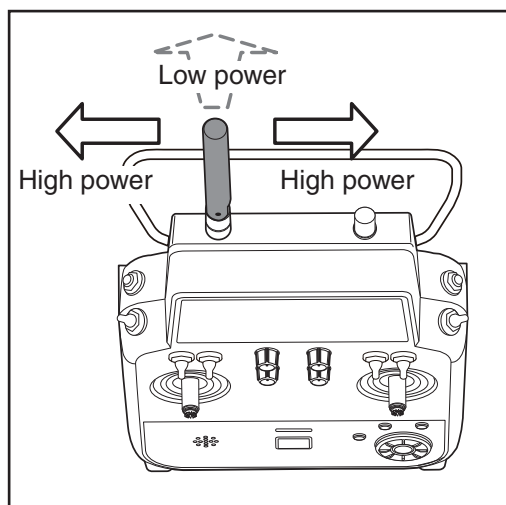
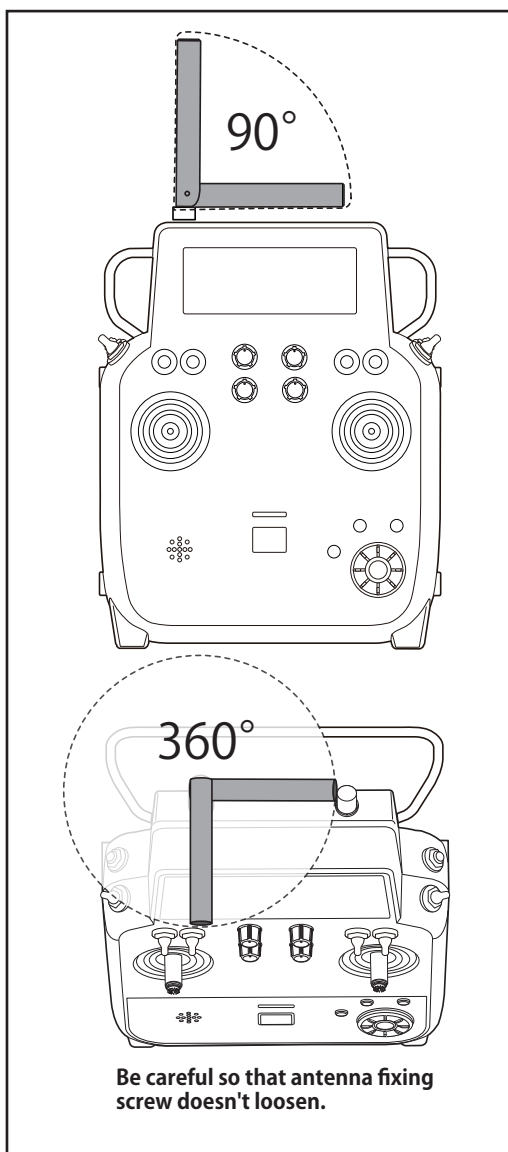

Attachment and removal of an antenna

FMT-03 can attach or remove an antenna.

Dust and water aren't supposed to be stuck in an antenna connector.

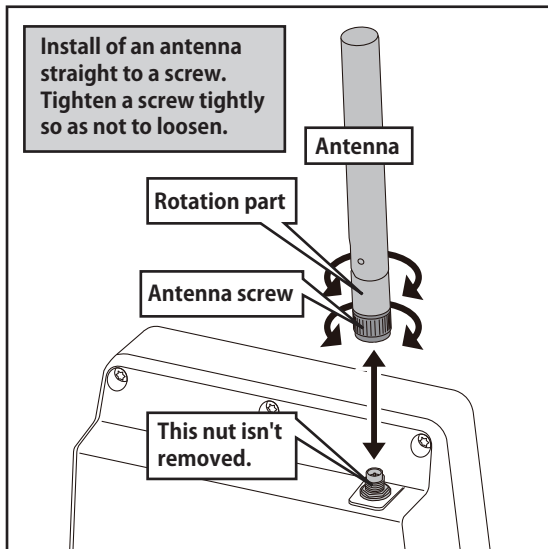

⚠ CAUTION

❗ **Be sure to install an antenna and do a flight.**

■ When there are no antennas, you can't control.

❗ **Please do not grasp the transmitter's antenna during flight.**

■ Doing so may degrade the quality of the RF transmission to the model.

⊘ **Do not carry the transmitter by the antenna.**

■ There is the danger that the antenna wire will break and operation will become impossible.

⊘ **Do not pull the antenna forcefully.**

■ There is the danger that the antenna wire will break and operation will become impossible.

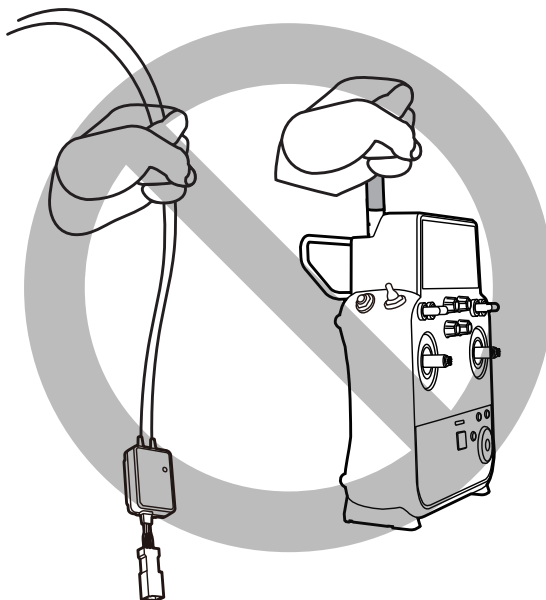

Switch (SA-SH)

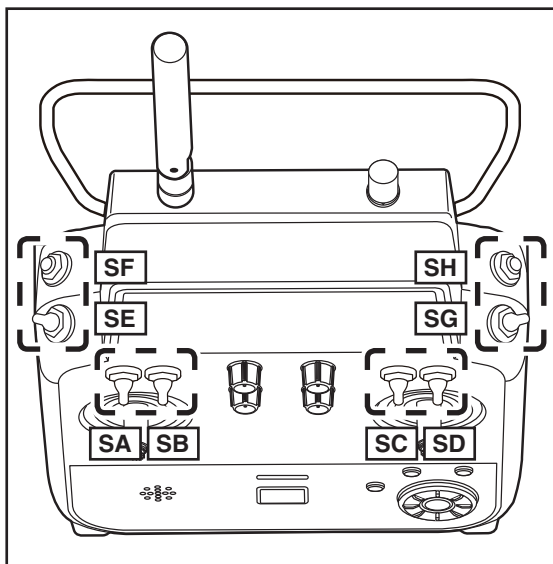

You can choose switch and set the ON/OFF-direction in the setting screen of the mixing functions.

Monitor LED

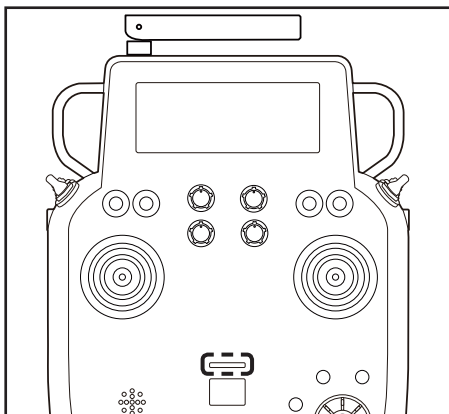

Monitor LED display

The status of the transmitter is displayed by LED at the upper part of the front of a FMT-03.

- RF-ON → Light Blue light
- RF-OFF → Violet light
- Starting → Red light
- Trainer Student → Blue light
- Range check mode → Slow blinking
- FASSTest receiver link mode → Fast blinking

Volume

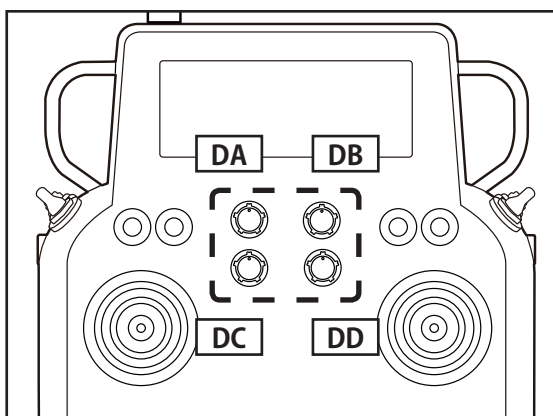

Volume DA - DD:

The volume DA-DD knobs allow analog input.

*The FMT-03 transmitter beeps when the volume knob reaches the center position.

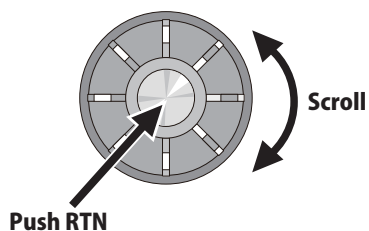
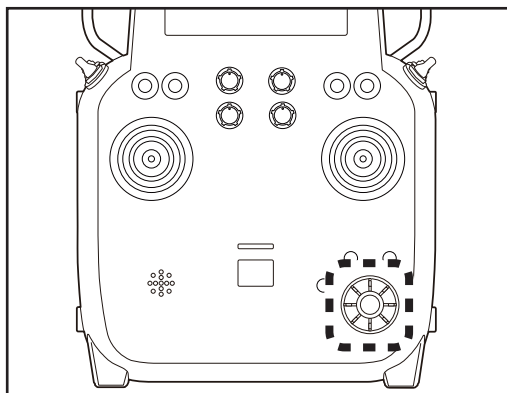

*You can use each setting screen of the mixing functions to select volumes and define the direction of a movement.

Edit dial

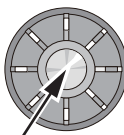
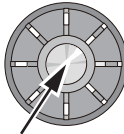

Edit dial operation

Data input operation is performed using the edit dial.

Edit dial operation	Action	Reaction
• Short 'push'  S1 RTN	If the screen has more than one page.	The cursor moves to the top of next page.
	If the screen have only one (1) page.	The cursor moves to the top of page.
	If the input data mode with blinking the setting data.	The input data is canceled.
	At the moving cursor mode.	Change to the input data mode.
	At the input data mode.	Change to the moving cursor mode.
	At the input data mode with blinking the setting data.	The data is entered.
• Push and hold for one (1) second.  S1 RTN	S1 At the HOME screen	Key lock On or Off
	RTN In the input data mode without blinking the setting data.	Reset to the initialized value.
• Scrolling  S1 Outline of Edit dial	Turn the outline of the edit dial.	The cursor moves accordingly.
	During the data input mode.	Increases or decreases values accordingly.

Movement of cursor, value input or mode selection:

Movement of the cursor on the menu screen and movement of the cursor among items on a setup screen can be controlled by scrolling your finger to the left and right in the direction of the arrow in the scrolling diagram above. You can also go to the next page, if there is a next page.

This scrolling technique is also used for data input, value input, mode selection, and similar operations. Examples include: Value, ON, OFF, INH, ACT, etc.

RTN button:

Push the RTN button when you want to open a setup screen or to switch between cursor move mode (reverse display) and data input mode (box display).

This button can also be used as the enter button when a confirmation message is displayed on the screen, etc.

S1 button:

When there is a next page on a menu screen or setup screen, you can go to that page by pushing the S1 button. In this case, the cursor moves to the screen title item of the page.

Exiting setup screen:

To end the operation on a setup screen and return to the menu screen, move the cursor to the screen title item and push the RTN button.

To return to home screen directly, push the Home/Exit button for 1 second.

Alternatively, move the cursor to the screen title item and push the RTN button to return to the home screen from a menu screen.

Home/Exit and U.menu/Mon. Button

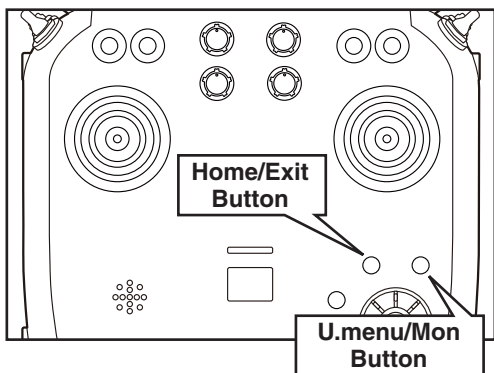

Home/Exit:

Push	Return to the previous screen
Push and hold	Return to the Home screen
It pushes from HOME screen.	To TELEMETRY display

U.menu/Mon:

Push	To Servo Monitor display
Push and hold	To User menu

Operation of sticks

2 sticks of FMT-03 can do linear operation in left, right, up or down.

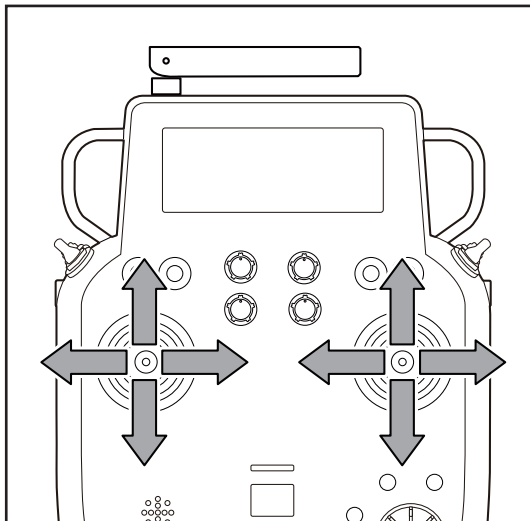

Maintenance example of a transmitter

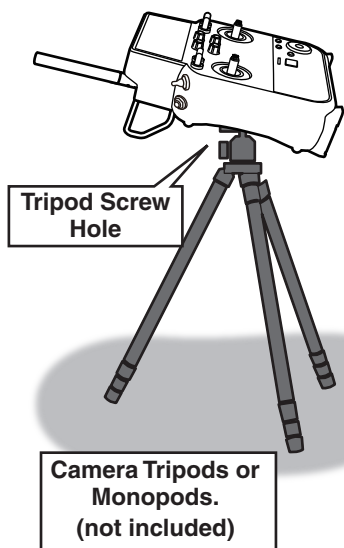

Hole of the VESA (VIDEO ELECTRONICS STANDARDS ASSOCIATION) standard is equipped in FMT-03. It's also possible to install it in the display arm (not included).

Micro SD card (secure digital memory card) (not included)

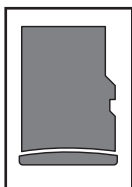

The FMT-03 transmitter model data can be stored by using any commonly found micro SD card. When FMT-03 transmitter update software is released, the software is updated using an micro SD card. The FMT-03 is capable of using micro SD cards with a memory size between SD:32MB -2GB SDHC:4GB-32GB.

CAUTION

 Be sure to turn off the power to the transmitter before inserting or removing the micro SD card.

 As the micro SD card is a precision device, do not use excessive force when inserting.

Micro SD card reader/writer

Saving model data and update files (released from Futaba) into the micro SD card, you can use those files on your FMT-03 transmitter. Equipment for reading and writing micro SD cards is available at most electronics stores.

Stored data

When you have a problem of saving or reading data after a long period of use, please get a new micro SD card.

*We do not have the responsibility of compensating any failure or damage to the data stored in the memory card no matter what the reason is. Be sure to keep a backup of your important data in your micro SD card.

Inserting/removing the micro SD card

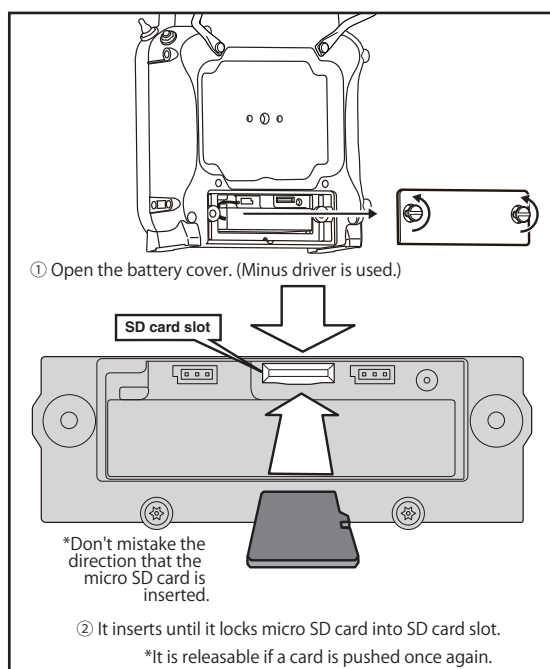

Connector

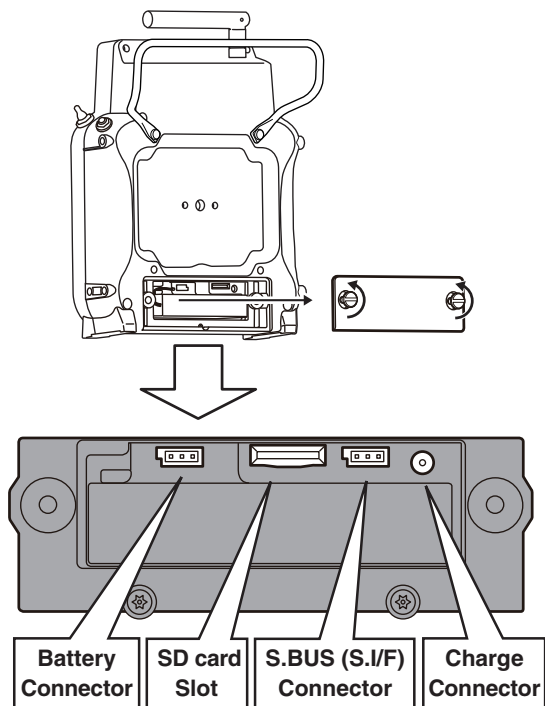

S.BUS connector (S.I/F)

When setting an S.BUS2 servo and telemetry sensor, connect them both here.

***Do not connect the battery.**

Connector for battery charger

This is the connector for charging the LiFe battery FT2F2100BV2 that is installed in the transmitter. Do not use any other chargers except the attached special charger corresponding to LiFe battery.

! WARNING

⊘ Do not connect any other chargers except the special charger to this charging connector.

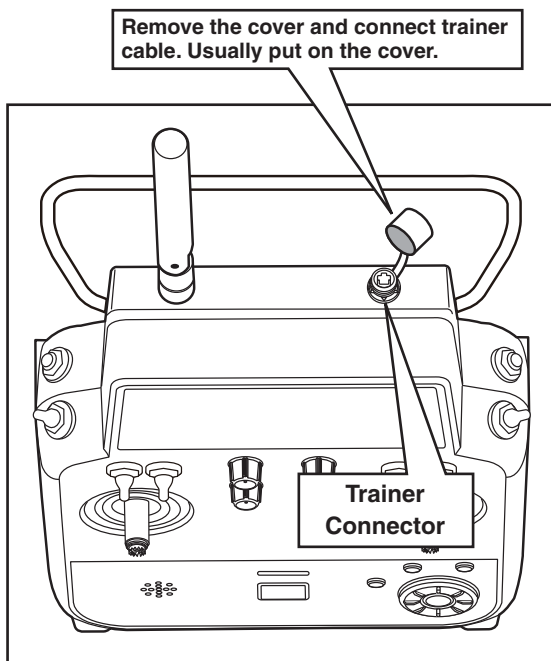

Connector for trainer function

When you use the trainer function, connect the optional trainer cable between the transmitters for teacher and student.

*You can set the trainer function on the Trainer Function screen in the System menu.

*A transmitter of anything but FMT-03 doesn't correspond to this trainer system.

*An exclusive option trainer code is needed to use a trainer system.

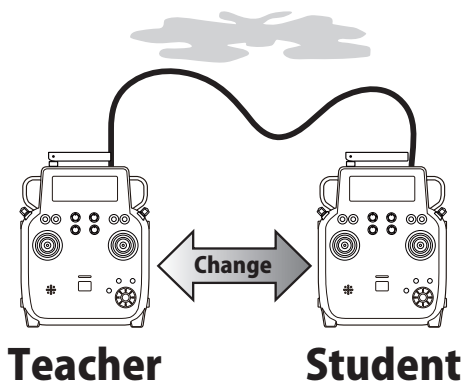

Installation and removal of the FT2F2100BV2 transmitter battery

Battery removal

Note: If you remove the battery while the power is on, the data you have set will not be saved.

1. Loosen 2 screws.
2. Open the battery cover.

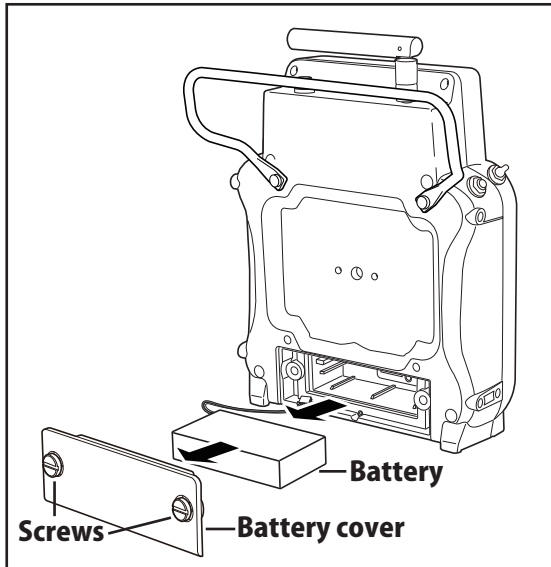

3. Disconnect the battery connector.
4. Remove the battery.
5. Close the battery cover completely.
6. Tighten 2 screws.

! WARNING

! Be careful not to drop the battery.

⊘ Never disconnect the battery connector from the FMT-03 transmitter after turning off the power until the screen is completely blank and the transmitter has shut down completely.

* Internal devices such as memories may be damaged.

* If there is any problem, the message "Backup Error" will be shown the next time when you turn on the power of the transmitter. Do not use the transmitter as it is. Contact supplier.

Attachment of the battery

1. Remove 2 screws.
2. Open the battery cover.
3. Insert a battery.
4. Connect the battery connector.
5. Close the battery cover completely.
6. Tighten 2 screws.

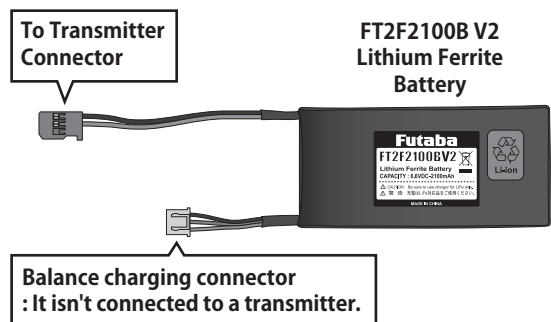

*The balance charge connector is not connected in the state where the battery is set to a transmitter.

! WARNING

⊘ When closing the battery cover, be careful that the battery cover does not pinch the battery lead wires.

*Shorting of the battery lead wires may lead to fire and abnormal heating and cause burns or fire disaster.

Receiver FMR-03

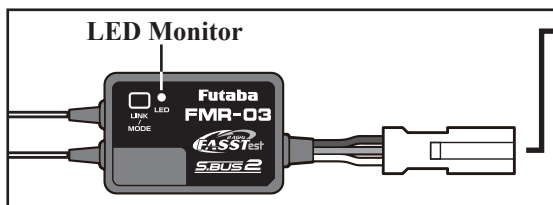

● S.BUS2 Connector

● Be careful about the direction of connector.

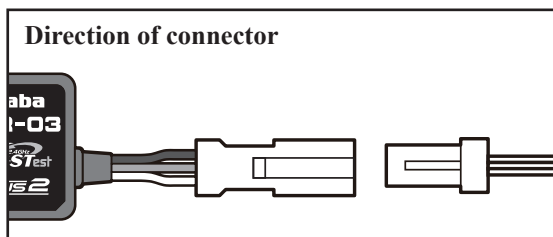

● LED Indication

Green	Red	Status
Off	Solid	No signal reception
Solid	Off	Receiving signals
Alternate blink		Unrecoverable error (EEPROM, etc.)

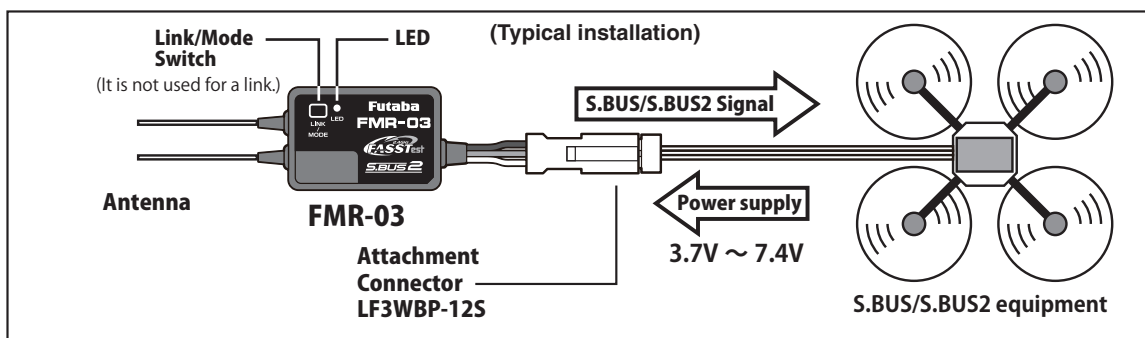

S.BUS Modes S.BUS2 ⇔ S.BUS

The FMR-03 is capable of changing its S.BUS modes as described in the table next. Please choose the mode which suited the use in the following procedure from the S.BUS or S.BUS2 modes.

- 1 Press and hold down the Link/Mode button on the FMR-03 receiver. [Transmitter is always OFF]
- 2 Turn the receiver on while holding down the Link/Mode button. After power up, the button can be released.
- 3 The LED should now be blinking red with green.
- 4 Each press of the Mode/Link button advances the receiver to the next mode. [Refer to S.BUS Mode table shown next.]
- 5 When you reach the mode that you wish to operate in, press and hold the Mode/Link button for more than 2 seconds.
- 6 When LED blinks in green with red, it is the completion of a mode change.
- 7 Please cycle the receiver power off and back on again after changing the S.BUS Mode.

FMR-03 S.BUS Mode table

	S.BUS mode	LED	Signal
Default	A	Red 1 time	<i>S.BUS2</i>
	B	Red 2 times	
	C	Red 3 times	<i>S.BUS</i>
	D	Red 4 times	
	E	Green 1 time	<i>S.BUS2</i>
	F	Green 2 times	
	G	Green 3 times	
	H	Green 4 times	
	I	Red Green 1 time	
	J	Red Green 2 times	
	K	Red Green 3 times	

*5 seconds after the receiver ON, LED shows S.BUS Mode.

Telemetry sensor (sold separately)

Your aircraft's data can be checked in the transmitter by connecting various telemetry sensors to the hub connector of the receiver.

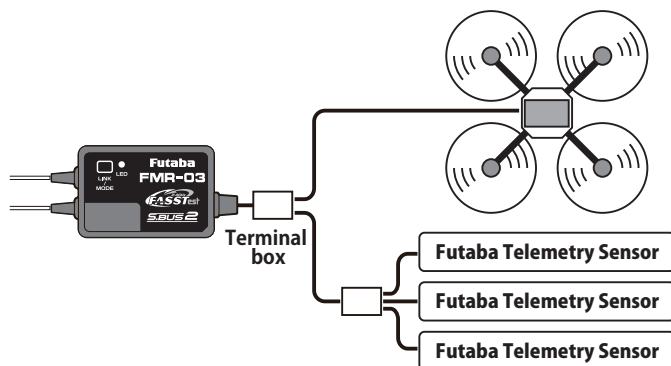

S.BUS/S.BUS2 Servo

Use of multi-copter control box corresponding to S.BUS/S.BUS2 is presupposing for FMR-03. S.BUS/S.BUS2 servo is connected as shown in the figure.

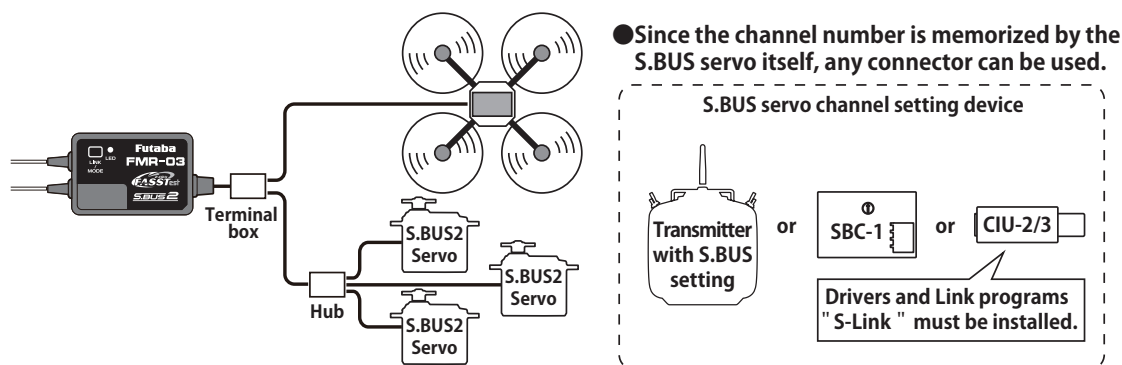

●6-Terminal box (TB16PP)

Six connectors can be inserted

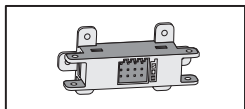

●4-Terminal box

Four connectors can be inserted

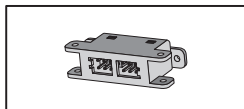

●Hub

Three connectors can be inserted.

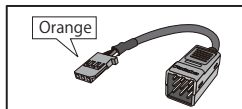

●Hub (Another power supply)

Used when using a separate power supply battery.

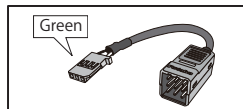

Receiver's Antenna Installation

The FMR-03 has two antennas. In order to maximize signal reception and promote safe modeling Futaba has adopted a diversity antenna system. This allows the receiver to obtain RF signals on both antennas and fly problem-free.

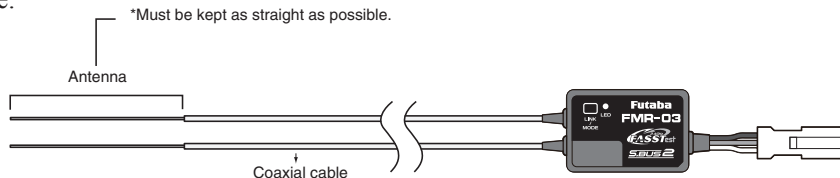

FMR-03 Receiver

To obtain the best results of the diversity function, please refer to the following instructions:

1. The two antennas must be kept as straight as possible. Otherwise it will reduce the effective range.
2. The two antennas should be placed at 90 degrees to each other.

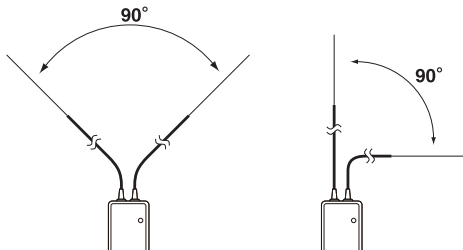

This is not a critical figure, but the most important thing is to keep the antennas away from each other as much as possible.

Larger models can have large metal objects that can effect the RF signal. In this case the antennas should be placed at both sides of the model. Then the best RF signal condition is obtained at any flying attitude.

3. The antennas must be kept away from conductive materials, such as metal, carbon and fuel tank by at least a half inch. The coaxial part of the antennas does not need to follow these guidelines, but do not bend it in a tight radius.
4. Keep the antennas away from the motor, ESC, and other noise sources as much as possible.

*The two antennas should be placed at 90 degrees to each other.

*The illustration demonstrates how the antenna should be placed.

*Install in a way that makes sure that the 2 antennas won't touch the ground. When an antenna touches the ground, there is danger which becomes control impossibility.

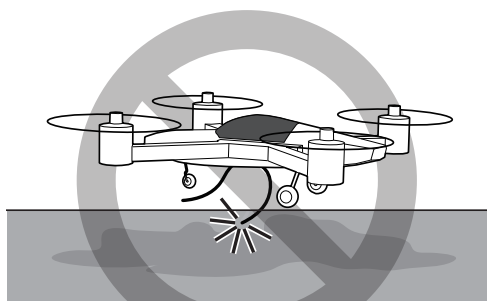

Antenna don't touch the ground.

Mounting the Servo

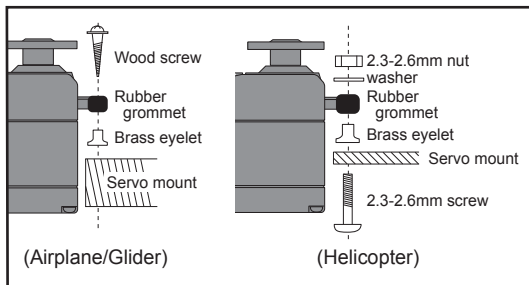

Servo lead wires

To prevent the servo lead cable from being broken by vibration during flight, provide a little slack in the cable and fasten it at suitable points. Periodically check the cable during daily maintenance.

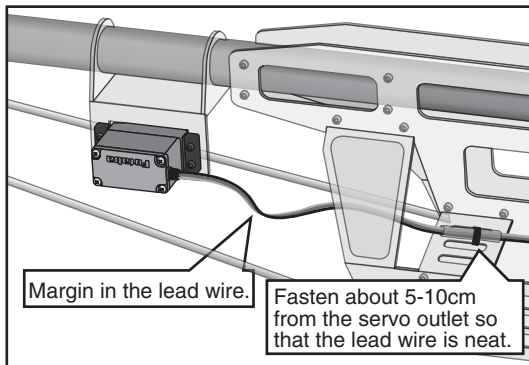

Mounting the power switch

When mounting a power switch to an airframe, make a rectangular hole that is a little larger than the total stroke of the switch so that you can turn the switch ON/OFF without binding.

Avoid mounting the switch where it can be covered by engine oil and dust. In general, it is recommended to mount the power switch on the side of the fuselage that is opposite the muffler.

Safety precautions when you install receiver and servos

⚠ WARNING

Connecting connectors

- ❗ Be sure to insert the connector until it stops at the deepest point.

How to protect the receiver from vibration

- ❗ Wrap the receiver with something soft such as foam rubber to avoid vibration.

Receiver's antenna

- ⊘ Never cut the receiver's antenna. Do not bind the receiver's antenna with the cables for servos.

- ❗ Locate the receiver's antenna as far as possible from metals or carbon fiber components such as frames, cables, etc.

*Cutting or binding the receiver's antenna will reduce the radio reception sensitivity and range, and may cause a crash.

Servo throw

- ❗ Adjust your system so that pushrods will not bind or sag when operating the servos to the full extent.

*If excessive force is continuously applied to a servo, the servo could be damaged due to force on the gear train and/or power consumption causing rapid battery drain.

Mounting servos

- ❗ Use a vibration-proof rubber (such as rubber grommet) under a servo when mounting the servo on a servo mount. And be sure that the servo cases do not push directly to the metal parts such as servo mount.

*If the servo case contacts the airframe directly, vibration will travel to and possibly damage the servo.

S.BUS/S.BUS2 device setting

S.BUS/S.BUS2 servos or a telemetry sensor can be connected directly to the FMT-03. Channel setting and other data can be entered for the S.BUS/S.BUS2 servos or sensors.

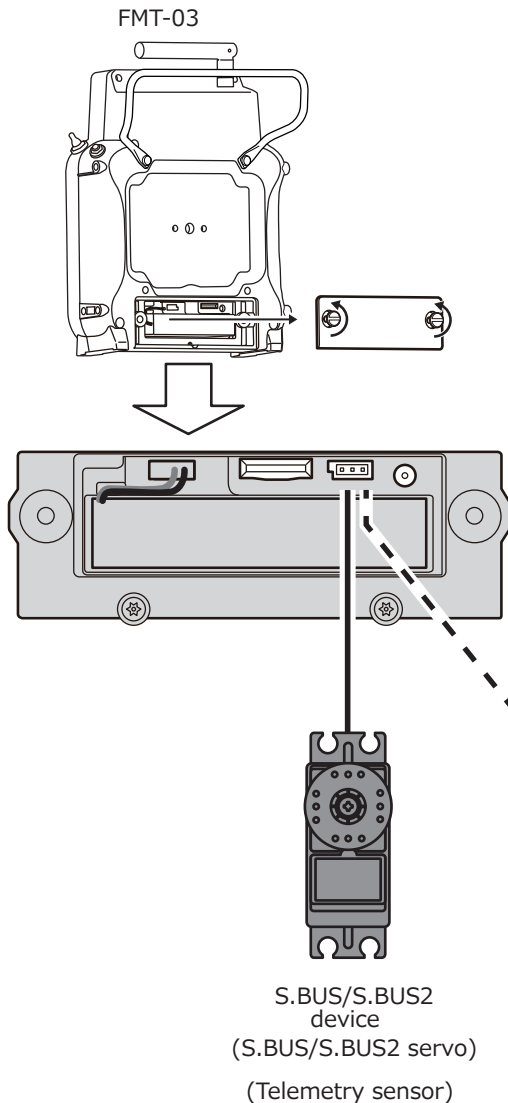

1. Connect the S.BUS/S.BUS2 device you want to set with as shown in the figure.
2. Turn on the transmitter power.
3. Call the setup screen.
 Servo: System Menu → S.BUS servo
 Sensor: Linkage Menu → Sensor
4. Perform setting in accordance with each screen.
5. This sets the channel and other data for each S.BUS2 servo, or telemetry device to be used with the S.BUS2 device or receiver.

*It is not necessary to carry out multiple connection of the battery like a T18MZ/T14SG.
 (It will damage, if it connects.)

*When you connect to a transmitter many servos which consume many current, please use "Another power supply HUB".
 And electric power is supplied to a servo with another power supply.

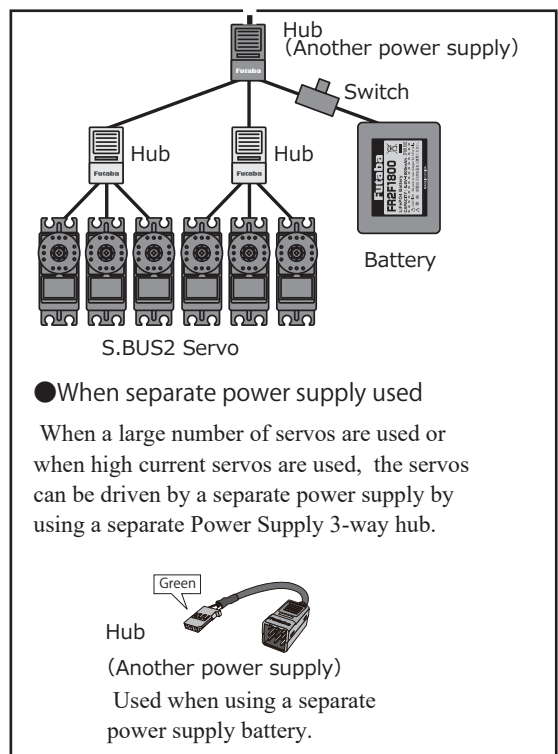

BASIC OPERATION

Battery Charging

Before charging battery, read the "Cautions for handling battery and battery charger" in the section "Battery Safety and Handling Instructions".

How to charge the LiFe battery FT2F2100BV2 for the transmitter

⚠ DANGER

⊘ The LiFe battery FT2F2100BV2 is only for your FMT-03. Do not use this battery for other equipment.

❗ Be sure to use the attached special charger to charge the battery.

When the battery will not be used for a long time, to prevent it from deteriorating we recommend that it be kept in about the half capacity state instead of fully charged. Also be careful that the battery does not enter the over-discharged state due to self-discharge. When the transmitter will not be used for a long time, you should always remove its battery. Periodically (about every 3 months) charge the battery.

[Method of charging battery]

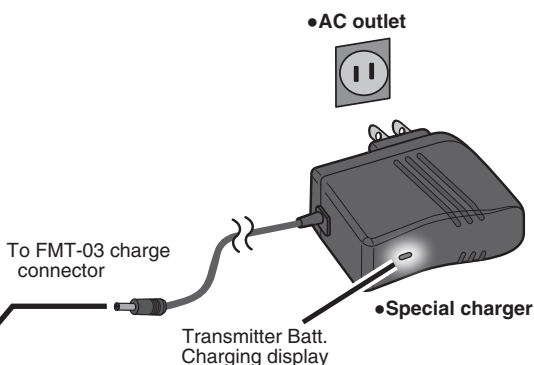
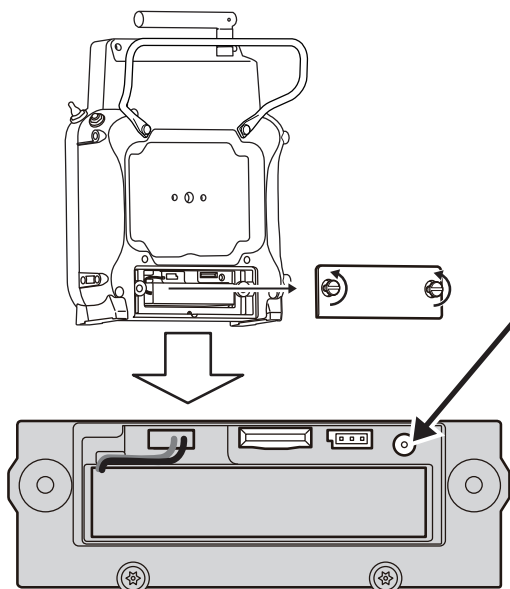

1. Plug the transmitter cord of the special charger into the charging connector in the transmitter.
2. Plug the charger into an AC outlet.
3. Check that the charging LED lights.

The charging time when charging the FT2F2100BV2 battery with the optional special charger is approximately 3 hours.

Charging

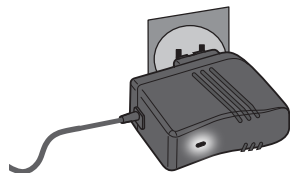

Red solid or Red blink



Charge completion

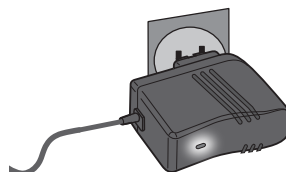

Green solid

4. Disconnect the charge plug.
5. Disconnect the AC plug.

How to turn transmitter power ON/OFF

When turning on the power, the FMT-03 transmitter will begin emitting RF automatically after it confirms the surrounding RF conditions.

When turning on the power of the transmitter

1. Turn on the power switch of the transmitter.



How to stop the transmitter

1. Turn off the power switch of the transmitter.

*The transmitter shuts down at once.

Low battery alarm

When the battery voltage reaches 6.2V, an audible alarm will sound. Land your aircraft immediately.

It can change from 6.0V to 7.6V by [SOUND] of [SYSTEM MENU].

It recommends using it with an initial value.

Registration of the user's name

If so desired, the FMT-03 transmitter can indicate the owner's name.

User's name setup screen

1. Turn on the power of the transmitter.
2. Select [USER NAME] in the system menu and Push the RTN button.

*The user name set up screen appears.

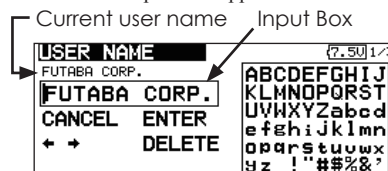

Changing the user name

1. Change the user name as described below:

[Moving cursor in input box]

Select [←] or [→], and push the RTN button.

[Deleting a character]

When [DELETE] is selected and the RTN button is pushed, the character immediately after the cursor is deleted.

[Adding a character]

When a candidate character is selected from the character list and the RTN button is pushed, that character is added at the position immediately after the cursor.

*A name of up to 12 characters long can be entered as the user name. (A space is also counted as 1 character.)

2. At the end of input, select [ENTER] and push the RTN button. (To terminate input and return to the original state, select [CANCEL] and push the RTN button.)

Home screen

Use the edit dial to select the following display area to call each setting screen, and Push the RTN button. The setting screen appears.

Home Screen

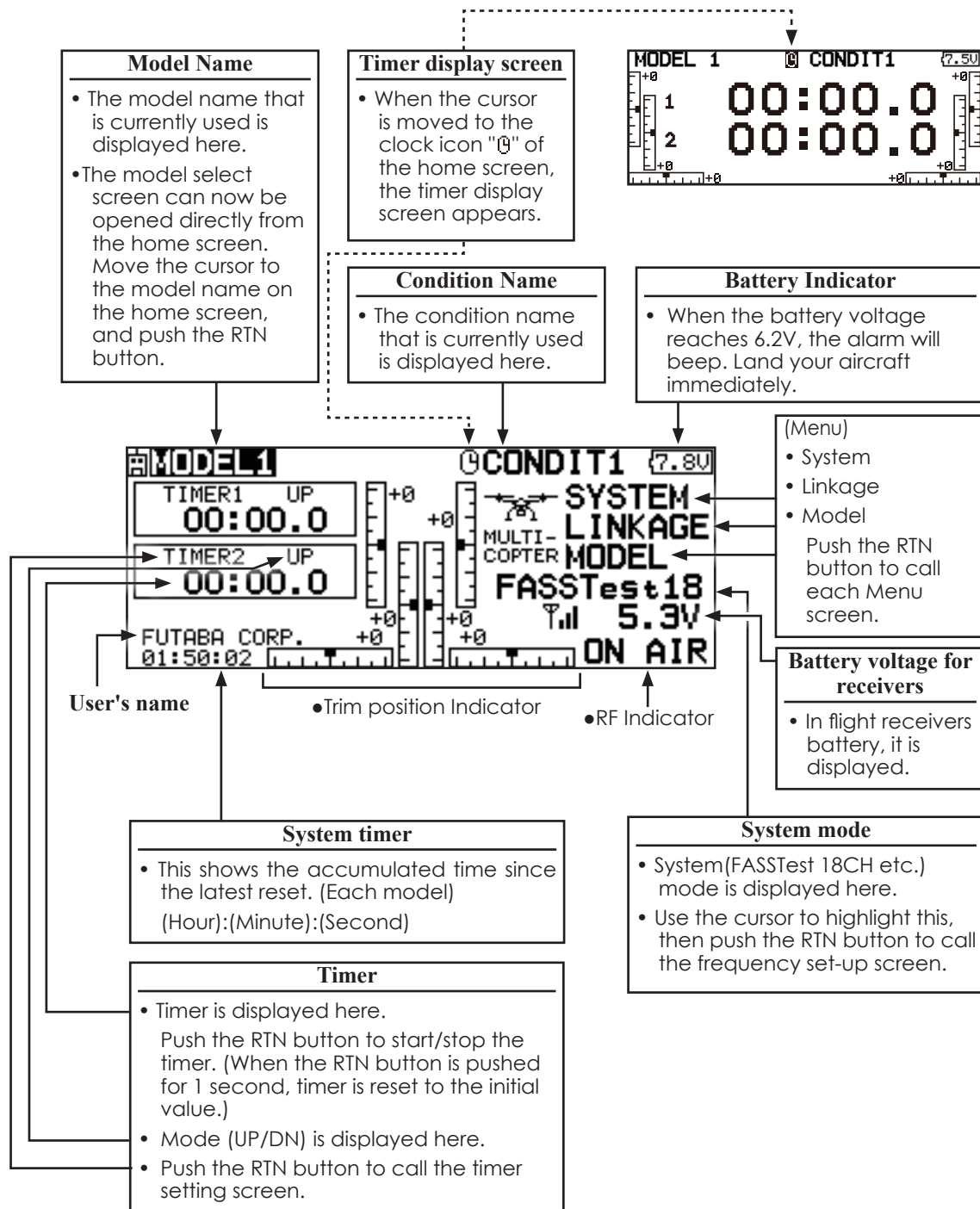

⚠ WARNING

! Be sure to confirm the model name before flying your aircraft.

! Check the battery voltage as often as possible and try to charge the battery earlier. If the battery alarm makes a sound, land your aircraft immediately.

*You can adjust the LCD contrast by the display setting in the system menu.

User Menu

A user menu which allows the user to customize and display frequently used functions has been added.

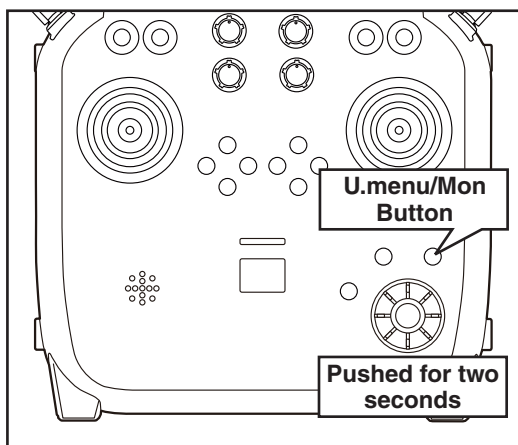

1. When the "U.MENU" button is pushed for two seconds, the user menu appears.

*Return to the home screen by pushing the EXIT button while the user menu is being displayed.

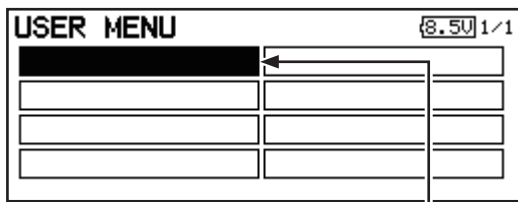

2. When the cursor highlights the space box, and the RTN button is pushed, the menu selection screen appears.

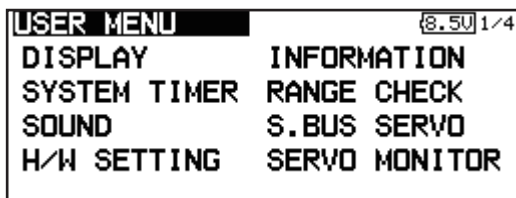

3. When the cursor is moved to the setting that you to set to the user menu and the RTN button is pushed, that setting screen is added to the user menu.
4. The registered setting screen can be called by moving the cursor to it and pushing the RTN button.

*When you want to delete an added screen from the user menu, highlight item you wish to delete, push and hold the RTN button for one second.

Key lock

To prevent the data from being changed by erroneous pushing of the edit dial during flight, a function which makes an edit dial impossible temporarily.

How to lock

1. The home screen is displayed.
2. Push the S1 button for about 1 second. "LOCK" is displayed and the edit dial is disabled.

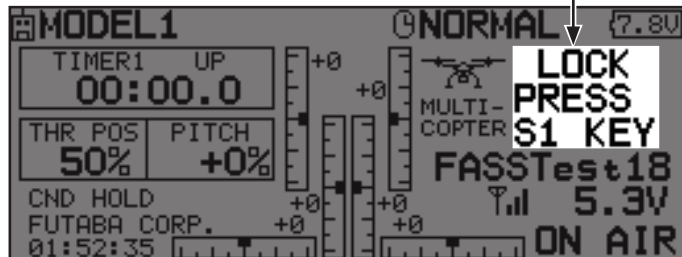

How to unlock

1. Push the S1 button for about 1 second in the edit dial locked state. The edit dial is enabled again.

*Two kinds of automatic locks can be chosen by **[DISPLAY]** of **[SYSTEM MENU]**.

STARTUP LOCK

Auto Lock functions automatically when the model changes or power is turned on.

*To temporarily allow access to the FMT-03 programming push and hold the S1 button for one second. Please note, the Auto Lock function timer will resume immediately once again.

*A PIN can also be set to protect the set data.

AUTOMATIC LOCK

Auto Lock functions automatically when there is no operation from the HOME screen display for a chosen number of seconds.

Link procedure (FMT-03 ⇔ FMR-03)

Each transmitter has an individually assigned, unique ID code. In order to start operation, the receiver must be linked with the ID code of the transmitter with which it is being paired. Once the link is made, the ID code is stored in the receiver and no further linking is necessary unless the receiver is to be used with another transmitter. When you purchase additional FMR-03 receivers, this procedure is necessary; otherwise the receiver will not work.

Link procedure

1. Place the transmitter and the receiver close to each other within half (0.5m) meter.

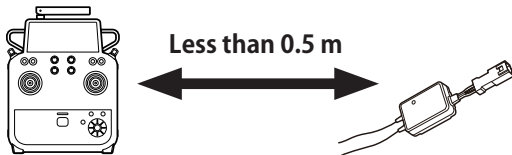

2. Turn on the transmitter.
3. Select [SYSTEM TYPE] at the Linkage menu and access the setup screen shown below by pushing the RTN button.

SYSTEM TYPE		(7.8V) 1/1
SYSTEM	FASSTest 18CH	
RECEIVER	SINGLE	
RECEIVER ID	114300031	
TELEMETRY	ACT 1.0s	
B.F./S VOLTAGE	3.8V	

:You can do this through the LINKAGE Menu and scroll to System and push RTN.

4. When you use two receivers on one model, you must change from [SINGLE] to [DUAL].

*Only two receivers can be used. In "DUAL", two setting items come out. Input, respectively.

SYSTEM TYPE		(7.9V) 1/1
SYSTEM	FASSTest 18CH	
RECEIVER	SINGLE	
RECEIVER ID	114300031	
TELEMETRY	ACT 1.0s	
B.F./S VOLTAGE	3.8V	

ID of a primary receiver displays. ID of a secondary receiver displays.

SYSTEM TYPE		(7.9V) 1/1
SYSTEM	FASSTest 18CH	
RECEIVER	DUAL	
RECEIVER ID	114300031	LINK
TELEMETRY	ACT 1.0s	
B.F./S VOLTAGE	3.8V	3.8V

In DUAL, a primary receiver is link previously. Next, a secondary receiver is link.

5. When changing battery fail-safe voltage from the initial value 3.8V, voltage is changed here.

SYSTEM TYPE		(7.8V) 1/1
SYSTEM	FASSTest 18CH	
RECEIVER	SINGLE	
RECEIVER ID	114300031	
TELEMETRY	ACT 1.0s	
B.F./S VOLTAGE	3.8V	

6. [RECEIVER-ID] is chosen by scrolling and the RTN button is pushed. The transmitter will emit a chime as it starts the linking process.

SYSTEM TYPE		(7.8V) 1/1
SYSTEM	FASSTest 18CH	
RECEIVER	SINGLE	
RECEIVER ID	LINKING	
TELEMETRY	ACT 1.0s	
B.F./S VOLTAGE	3.8V	

7. When the transmitter starts to chime, power on the receiver. The receiver should link to the transmitter within about 1 second.

In "Link" Mode



8. If linking fails, an error message is displayed. Bring the transmitter closer to the receiver and repeat the procedure above from Step 2.

9. ACT will be chosen if telemetry is used. It is INH when not using it.

SYSTEM TYPE		(7.8V) 1/1
SYSTEM	FASSTest 18CH	
RECEIVER	SINGLE	
RECEIVER ID	114300031	
TELEMETRY	ACT 1.0s	
B.F./S VOLTAGE	3.8V	

10. When a telemetry function is enabled, the receiving interval (down-link interval) of sensor data can be changed. If a DL interval is increased, the response of the sensor data display becomes slower, but stick response will improve.

Initial value: 1.0s

Adjustment range: 0.1s~2.0s

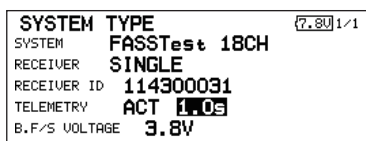

*If there are many FASSTest systems turned on around your receiver, it might not link to your transmitter. In this case, even if the receiver's LED stays solid green, unfortunately the receiver might have established a link to one of other transmitters. This is very dangerous if you do not notice this situation. In order to avoid the problem, we strongly recommend you to doublecheck whether your receiver is really under control by your transmitter by giving the stick input and then checking the servo response.

*Do not perform the linking operation when the drive motor is connected or the engine is running.

*When you use two receivers, please be sure to setup a "primary" and "secondary" in the "dual" mode.

*Telemetry function cannot be used for the 2nd receiver.

* You must link one receiver at a time. If both power supplies to the receivers are switched on simultaneously, data is received incorrectly by the transmitter.

* You cannot link three receivers.

* Link is required when a system type is changed.

* Linking is required whenever a new model is made.

WARNING

 After the linking is done, please cycle receiver power and check that the receiver to be linked is really under the control of the transmitter.

 Do not perform the linking procedure with motor's main wire connected or with the engine operating as it may result in serious injury.

Range Testing Your R/C System

It is extremely important to range check your models prior to each flying session. This enables you to ensure that everything is functioning as it should and to obtain maximum enjoyment from your time flying. The FMT-03 transmitter incorporates a system that reduces its power output and allows you to perform such a range check.

Range check mode

1. While pushing previously "U.menu/Mon" button.



2. FMT-03 Power ON.

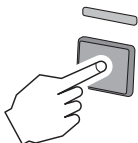

3. Scroll to "NO" and push RTN.

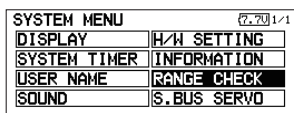

4. "RANGE CHECK" is chosen from "SYSTEM MENU" and push RTN.

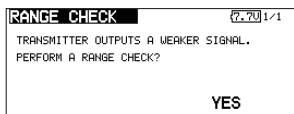

5. "YES" is chosen from "RANGE CHECK" and push RTN.

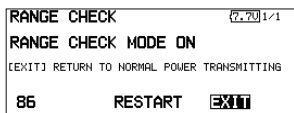

During this mode, the RF power output is reduced so the range test can be performed. In addition, when this mode is activated the right LED on the front of the transmitter starts blinking and the transmitter gives users a warning with a beeping sound every 3 seconds.

The "Range check mode" continues for 90 seconds and after that the power will return to the normal level. To exit the "Range check mode" before the 90 seconds, select the "EXIT" at the screen and touch the RTN button again. This mode is available one time only so if you need to re-use this function the transmitter power must be cycled. NEVER start flying when the "Range check mode" is active.

Should you require additional time to perform a range check, highlight Restart before your time expires and press the RTN button one time.

Range check procedure

1. With the "Range check mode" on, walk away from the model while simultaneously operating the controls. Have an assistant stand by the model to confirm that all controls are completely and correctly operational. You should be able to walk approximately 30-50 paces from the model without losing control.

2. If everything operates correctly, return to the model. Set the transmitter in a safe, yet accessible, location so it will be within reach after starting the engine or motor. Be certain the throttle stick is in the low throttle position, then start the engine or motor. Perform another range check with your assistant holding the aircraft with the engine running at various speeds. If the servos jitter or move inadvertently, there may be a problem. We would strongly suggest you do not fly until the source of the difficulty has been determined. Look for loose servo connections or binding pushrods. Also, be certain that the battery has been fully charged.

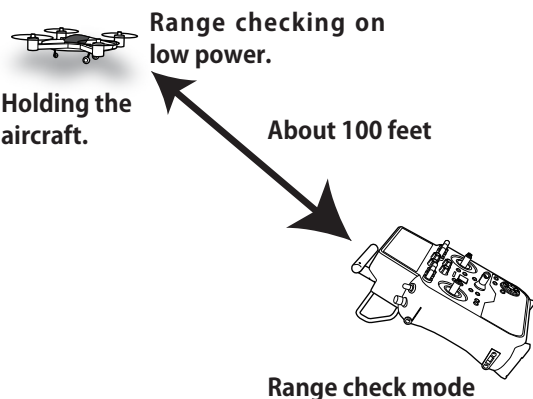

WARNING

Do not fly in the range check mode.

*Since the range of the radio waves is short, if the model is too far from the transmitter, control will be lost and the model will crash.

Cannels connection by multicopter type

The FMT-03 transmitter channels are automatically assigned for optimal combination according to the type selected with the Model Type function of the Linkage Menu. The channel assignment (initial setting) for each model type is shown below. Connect the receiver and servos to match the type used.

*The set channels can be checked at the Function screen of the Linkage Menu. The channel assignments can also be changed.

For more information, read the description of the Function menu.

Multicopter

●FASSTest 18CH

CH	Multicopter
1	Aileron
2	Elevator
3	Throttle
4	Rudder
5	Gyro
6	Gyro2
7	Gyro3
8	CAM TILT
9	CAMERA PAN
10	CAMERA REC
11	Mode
12	AUX5
13	AUX4
14	AUX3
15	AUX2
16	AUX1
DG1	SW SH
DG2	SW SA

●FASSTest 12CH

CH	Multicopter
1	Aileron
2	Elevator
3	Throttle
4	Rudder
5	Gyro
6	Gyro2
7	Gyro3
8	CAM TILT
9	CAMERA PAN
10	CAMERA REC
11	Mode
12	AUX5

SYSTEM MENU

The System Menu sets up functions of the transmitter: This does not set up any model data.

- Select [SYSTEM] at the home screen and call the system menu shown below by pushing the RTN button.
- Scrolling the edit dial to select the function you want to set and call the setup screen by pushing the RTN button.

- Select the function name and return to the System menu by pushing the RTN button or pushing the Home/Exit button.

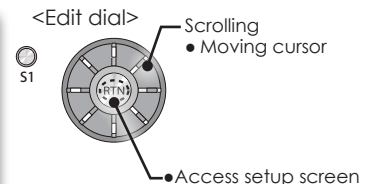
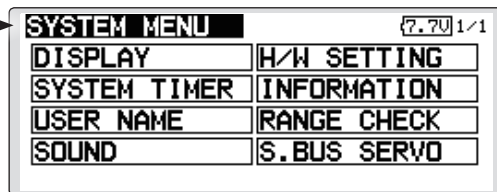

System Menu functions table

[DISPLAY]: LCD contrast and back light adjustment.

[SYSTEM TIMER]: Resets the accumulated timer for each model.

[USER NAME]: User name registration.

[SOUND]: Various volume control and low battery setting.

[H/W SETTING]: H/W reverse, stick mode, stick calibration, and switch position.

[INFORMATION]: Displays the program version, micro SD card information, and language selection.

[RANGE CHECK]: A transmitting output is lowered and the check before a flight is carried out.

[S.BUS SERVO]: S.BUS servo setting.

The following LCD screen adjustments and auto power off setting are possible:

- Select [DISPLAY] at the system menu and call the setup screen shown below by pushing the RTN button.

- Select the function name and return to the System menu by pushing the RTN button or pushing the Home/Exit button.

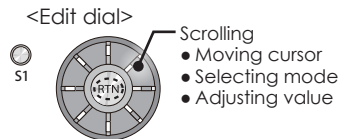
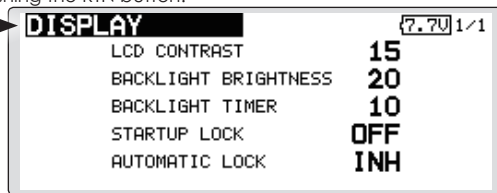

- Backlighting brightness adjustment
- Backlighting off timer adjustment
- Key lock setup

A PIN can also be set to protect the set data.

LCD contrast adjustment

1. Scrolling the edit dial to select "LCD CONTRAST" and push the RTN button to switch to the data input mode and adjust the contrast by turning the edit dial to the left and right.

Setting range: (Lighter) 0 to 30 (Darker)

Initial value: 15

Push the RTN button to end adjustment and return to the cursor move mode.

- *Adjust to the contrast while watching the screen display.
- *When you want to reset the contrast to the initial state, select "LCD CONTRAST" and push the RTN button for 1 second.

Backlight brightness adjustment

1. Scrolling the edit dial to select "BACKLIGHT BRIGHTNESS" and push the RTN button to switch to the data input mode and adjust the contrast by turning the edit dial to the left and right.

Setting range: (Darker) 0 to 30 (Lighter)

Initial value: 10

Push the RTN button to end adjustment and return to the cursor move mode.

- *Adjust to the brightness while watching the screen display.
- *When you want to reset the contrast to the initial state, select "BACKLIGHT BRIGHTNESS" and push the RTN button for 1 second.

Back-light off-timer

1. Select "Back-light timer" and push the RTN button to switch to the data input mode and adjust the back-light off-timer by scrolling the edit dial.

"OFF TIMER": Adjust the time when the back-light turns off after operating the edit dial.

Setting range: 10 to 240 sec (each 10 sec), OFF (always on)

Initial value: 10 sec

- *When you want to reset the value to the initial state, push the RTN button for one second.

2. Push the RTN button to end adjustment and return to the cursor mode.

- *If the back light is on for a long time, consumption current will increase.

Start lock

Auto Lock functions automatically when the model changes or power is turned on.

- *To temporarily allow access to the FMT-03 programming push and hold the S1 button for one second. Please note, the Auto Lock function timer will resume immediately once again.

1. Select "STARTUP LOCK" and push the RTN button to switch to the data input mode and adjust the ON or OFF by scrolling the edit dial.

Setting range: ON or OFF

Initial value: OFF

Set PIN ID

A PIN can also be set to protect the set data.

- ***Please do not forget the ID you set here.** You have to input the ID in order to unlock the ID lock on the home screen. If you do not need the ID lock feature, please set the ID for "00000000".

1. Select "ID" and push the RTN button to switch to the ID input screen.
2. Scrolling the edit dial to select "00000000" and push the RTN button to switch to the data input mode and adjust the number by turning the edit dial to the left and right. Push the RTN button to end adjustment and return to the cursor move mode.
3. UNLOCK: Push the S1 button for about 1 second in the edit dial locked state. And input the ID you have set. The edit dial is enabled again.

Automatic lock

Auto Lock functions automatically when there is no operation from the HOME screen display for a chosen number of seconds.

1. Scrolling the edit dial to select "AUTOMATIC LOCK" and push the RTN button to switch to the data input mode and adjust the time by turning the edit dial to the left and right.

Setting range: INH, 0 to 120 (s)

Initial value: INH

SYSTEM TIMER Resets the accumulated timer.

This function resets the system timer displayed on the home screen.

- FMT-03 has two type system timers.

TOTAL timer: Displays the total accumulated time on the transmitter from the last time the timer was reset.

MODEL timer: Displays the total accumulated time on each model from the last time the timer was reset.

- System timer displayed on the home screen can be selected.

- Select [SYSTEM TIMER] at the system menu and call the setup screen shown below by pushing the RTN button.

- Select the function name and return to the System menu by pushing the RTN button or pushing the Home/Exit button.

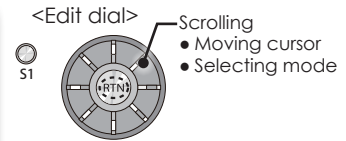
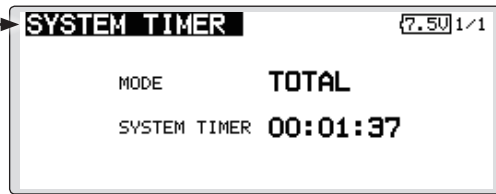

Timer selection

1. Move the cursor to the [MODE] item and push the RTN button to switch to the data input mode.

Select the mode by scrolling the edit dial and push the RTN button.

TOTAL: Displays the total timer on the home screen.

MODEL timer: Displays the model timer on the home screen.

Timer reset

1. Move the cursor to the [SYSTEM TIMER] item and reset the timer to "00:00:00" by pushing the RTN button for 1 second. After reset, the timer restarts from "00:00:00".

USER NAME

User name registration

This function registers the FMT-03 user name.

*A name of up to 12 characters can be entered as the user name. (Space is also counted as 1 character.)

- Select [USER NAME] at the system menu and call the setup screen shown below by pushing the RTN button.

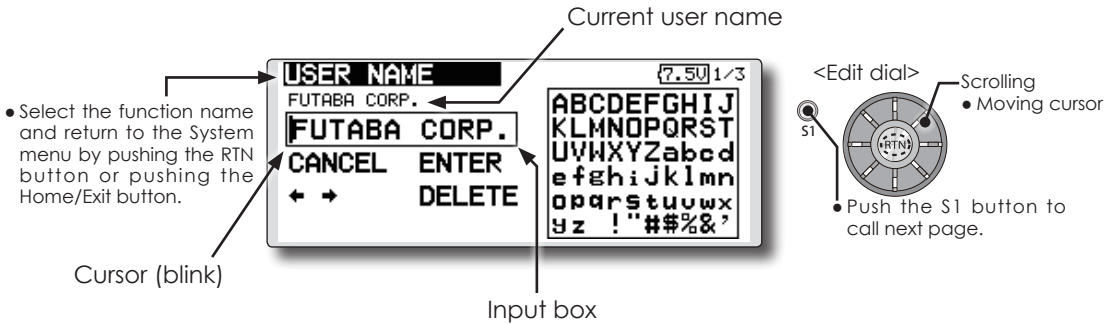

User name registration

1. Change the user name as described below:

[Moving cursor in input box]

Select [←] or [→], and push the RTN button.

[Deleting a character]

When [DELETE] is selected and the RTN button is pushed, the character immediately after the cursor is deleted.

[Adding a character]

When a candidate character is selected from the character list and the RTN button is pushed, that character is added at the position immediately after the cursor.

*A name of up to 12 characters long can be entered as the user name. (A space is also counted as 1 character.)

2. At the end of input, select [ENTER] and push the RTN button. (To terminate input and return to the original state, select [CANCEL] and push the RTN button.)

(Character list 1/3)

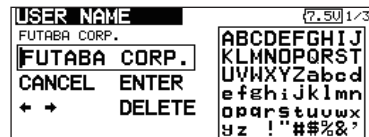

(Character list 2/3)

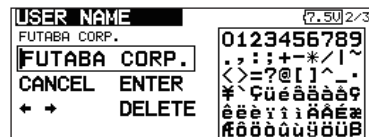

(Character list 3/3)



SOUND

Turns off the buzzer.

3 independent sound volumes: "WARNING", "VOICE" and others, are available.

"LOW BATTERY" adjusts low battery alarm voltage to match a battery.

- Select [SOUND] at the system menu and access the setup screen shown below by pushing the RTN button.

- Select the function name and return to the System menu by pushing the RTN button or pushing the Home/Exit button.

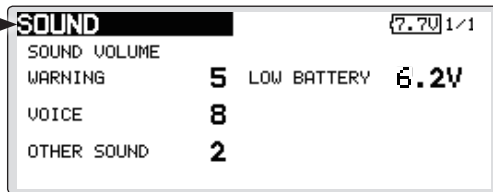

<Edit dial>

S1

- Scrolling
- Moving cursor
- Adjusting value

Sound volume operation

1. Move the cursor to the [WARNING][VOICE] or [OTHER SOUND] item and push the RTN button to switch to the data input mode.

2. Select the volume by scrolling the edit dial.

*The display blinks.

3. Push the RTN button.

Low battery voltage operation

1. Move the cursor to the [LOW BATTERY] item and push the RTN button to voltage to the data input mode.

2. Select the voltage by scrolling the edit dial.

*The display blinks.

3. Push the RTN button.

H/W SETTING

Hardware reverse and stick mode, stick calibration, switch position

H/W reverse

This function reverses the operation signal of the sticks, switches, trimmer levers, and knobs.

Note: This setting reverses the actual operation signal, but does not change the display of the indicators on the display. Use the Normal mode as long as there is no special reason to use the Reverse mode.

Stick mode

This function changes the stick mode of transmitter.

Note: This will not change the throttle ratchet, etc. Those are mechanical changes that must be done by a Futaba service center.

Note: After changing the mode, it is applied when setting a new model. It is not applied to an existing model.

Stick calibration

J1-J4 stick correction can be performed.

Note: It does not carry out, when there is no necessity.

Switch

For set the switch type and position amount when the stock configuration is changed.

- Select [H/W SETTING] at the system menu and call the setup screen shown below by pushing the RTN button.

- Select the function name and return to the System menu by pushing the RTN button or pushing the Home/Exit button.

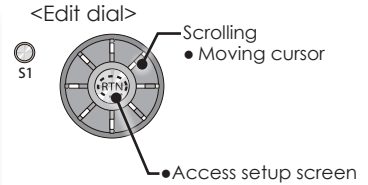
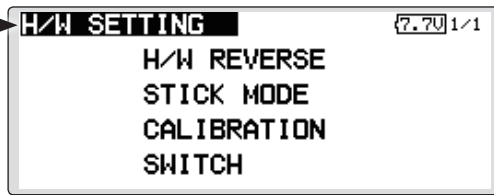

Operation direction reversal method

1. Select [H/W REVERSE] and call the setup screen shown below by pushing the RTN button.

H/W REVERSE						(7.5U) 1/2
H/W	MODE	H/W	MODE	H/W	MODE	
J1	NORM	SA	NORM	SE	NORM	
J2	NORM	SB	NORM	SF	NORM	
J3	NORM	SC	NORM	SG	NORM	
J4	NORM	SD	NORM	SH	NORM	

2. Use the edit dial to move the cursor to the "MODE" item corresponding to the H/W (hardware) you want to reverse and push the RTN button to switch to the data input mode.
3. Change the mode by turning the edit dial to the left or right. The display blinks. When the RTN button is pushed, the operation direction is reversed. (To terminate mode change, turn the edit dial or push the S1 button.)

"NORM": Normal operation direction

"REV" : Operation direction is reversed.

Operation direction reversal method

1. Select [STICK MODE] and call the setup screen shown below by pushing the RTN button.

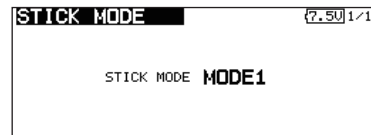

2. Use the edit dial to move the cursor to the "STICK MODE" item and push the RTN button to switch to the data input mode.
3. Change the mode by turning the edit dial to the left or right. The display blinks. When the RTN button is pushed, the stick mode is changed. (To terminate mode change, turn the edit dial or push the S1 button.)

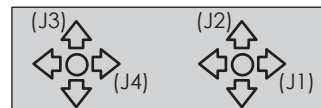

Mode	J1	J2	J3	J4
1	Aileron	Throttle	Elevator	Rudder
2	Aileron	Elevator	Throttle	Rudder
3	Rudder	Throttle	Elevator	Aileron
4	Rudder	Elevator	Throttle	Aileron

Stick calibration method

*J3-J4 correction is described below. J1-J2 corrections are performed using the same procedure.

1. Select [CALIBRATION] and access the setup screen shown below by pushing the RTN button.

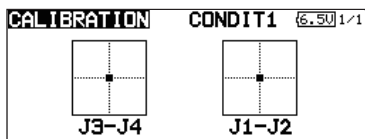

2. Move the cursor to the J3-J4 button and push the RTN button.

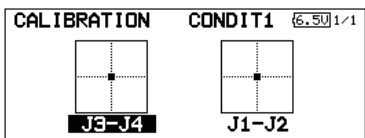

3. Move the J3-J4 stick to the neutral position and push the RTN button for one second.

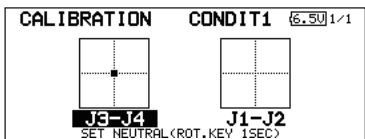

4. Set the J3-J4 stick fully to the bottom- right and wait until the buzzer sounds.

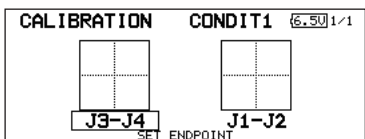

5. Set the J3-J4 stick fully to the top-left and wait until the buzzer sounds.

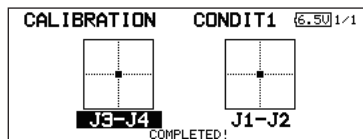

6. The above completes the correction operation. Operate and check if stick correction was performed normally.

Operation switch setting method

1. Select [SWITCH] and call the setup screen shown below by pushing the RTN button.

SWITCH			
H/W	SETTING	H/W	SETTING
SA	3Pos	SE	3Pos
SB	3Pos	SF	3Pos
SC	3Pos	SG	3Pos
SD	3Pos	SH	3Pos

The 'SWITCH' title is highlighted with a black bar. The '7.60 1/1' value is visible in the top right corner.

2. Use the edit dial to move the cursor to the "SA-SH" item corresponding to the switch you want to change and push the RTN button to switch to the data input mode.
3. Change the "2Pos" or "3Pos" by turning the edit dial to the left or right. The display blinks. It will decide, if the RTN button is pushed. (To terminate mode change, turn the edit dial or push the S1 button.)

"3Pos": 3 position switch

"2Pos" : 2 position switch

INFORMATION Displays the program version, Micro SD card information, and product ID.

The FMT-03 system program version information, micro SD card information (maximum and vacant number of model data), and product ID are displayed on the Information screen.

*When the micro SD card is not inserted, the micro SD card information is not displayed.

The language displayed in home, menu, and setup screen is selectable.

Also, the unit of a telemetry display can also be changed.

- Select [INFORMATION] at the system menu and call the setup screen shown below by pushing the RTN button.

- Select the function name and return to the System menu by pushing the RTN button or pushing the Home/Exit button.

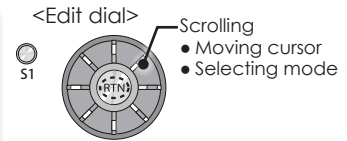
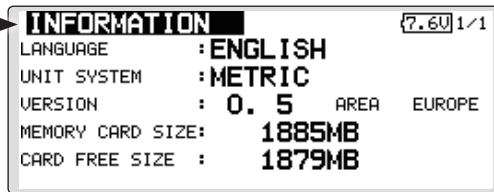

Information

"VERSION": FMT-03 system program version information

"MEMORY CARD SIZE": Maximum number of model data (Micro SD card)

"CARD FREE SIZE": Vacant number of model data (Micro SD card)

Language selection

1. Use the edit dial to move the cursor to the "LANGUAGE" item and push the RTN button to switch to the data input mode.
2. Change the language by turning the edit dial to the left or right. The display blinks. When the RTN button is pushed, the language is changed. (To terminate mode change, turn the edit dial or push the S1 button.)

Unit system selection

1. Use the edit dial to move the cursor to the "UNIT SYSTEM" item and push the RTN button to switch to the data input mode.
2. Change the unit by turning the edit dial to the left or right. The display blinks. When the RTN button is pushed, the unit is changed. (To terminate mode change, turn the edit dial or push the S1 button.)

RANGE CHECK

Before a flight ground range check.

The 'range check mode' reduces the transmission range of the radio waves to allow for a ground range check.

*The range check mode, when activated, will continue for 90 seconds unless the user exits this mode early. When the progress bar reaches 90 second mark, the RF transmission automatically returns to the normal operating power.

- Pushing [U.menu/Mon] button is continued. → Turn ON the transmitter's power switch. (First, a throttle stick is made into a low position, and turns on a power supply.) It is displayed as "TRANSMIT?". "NO" is chosen and [RTN] is pushed.
- Select [RANGE CHECK] at the system menu and call the setup screen shown below by pushing the RTN button.

- Select the function name and return to the System menu by pushing the RTN button or pushing the Home/Exit button.

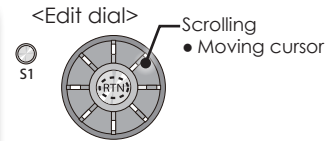
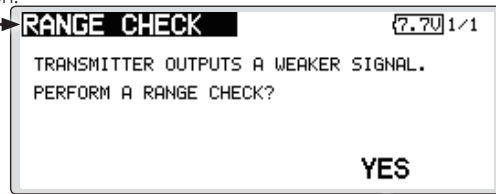

- [Yes] is chosen and [RTN] is pushed.

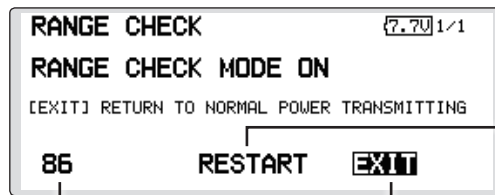

- Range Check mode timer is returned to 90.

- Remaining time of RANGE CHECK MODE.
- Range Check mode is disabled.

Rotation Range Check method

1. Pushing [U.menu/Mon] button is continued. → Turn ON the transmitter's power switch. (First, a throttle stick is made into a low position, and turns on a power supply.) It is displayed as "TRANSMIT?". "NO" is chosen and [RTN] is pushed.
*For safety, the RANGE CHECK mode can not be selected while the RF transmission is active.
2. In the system menu, choose the 'Range Check' selection from the menu options.
3. The Range Check screen is displayed. To activate the Range Check mode push the [Yes] button. During the Range Check period, the RF power is reduced to allow the ground range tests to be performed.
4. The Range Check function automatically exits after the 90 second time limit has

⚠ WARNING

Do not fly in the range check mode.

- Since the range of the radio waves is short, if the model is too far from the transmitter, control will be lost and the model will crash.

expired. The count down time is displayed on the transmitter's screen. Should you complete the range check before the 90 seconds has pushed, push the [Exit] button.

*When the [RESTART] button is pushed, the range check mode timer is returned to 90.

*Please note, upon expiration of the 90 seconds, or when [Exit] is selected, the transmitter will automatically return to the normal RF operation as noted on the display.

*Once the FMT-03 is transmitting at full power, it is not possible to enter the Range Check mode without first switching the transmitter Off and back On. This has been designed to prevent a modeler from inadvertently flying in the Range Check mode.

5. When the [Exit] button is pushed, the Range Check mode is disabled and the FMT-03 will begin transmitting at full power.

*After exiting the Range Check mode, the function cannot be selected again. To select the Range Check mode again you must cycle the transmitter power switch.

S.BUS SERVO

An S.BUS/S.BUS2 servo can memorize the channel and various settings internally. Servo setting changes can be performed on the FMT-03 screen by wiring the servo as shown in the figure.

•Servo ID number

Individual ID numbers are memorized for your S.BUS servos in your FMT-03. When a servo is used (as shown at the right), the servo ID number is automatically read by the transmitter.

If you use multiple S.BUS servos and do not want to change the settings on all that are mounted in a fuselage, only the desired servo in the group can be set by entering the ID of that specific servo.

* With S.BUS/S.BUS2 servos of use, there are a function which can be used, and an impossible function and a display screen changes.

(Only the function which can be used by a servo is displayed.)

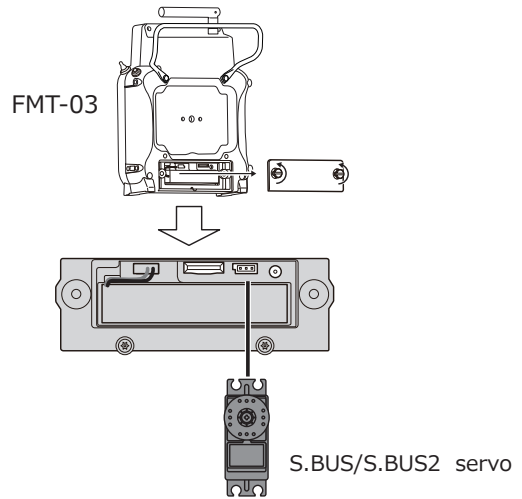

* After reading completion, with connection of the above figure, if a stick is moved, the test of operation of the servo can be operated and carried out.

*It is not necessary to carry out multiple connection of the battery like a T18MZ/T14SG.

(It will damage, if it connects.)

*When you connect to a transmitter with many servos which may consume extra current, please use "Another power supply HUB". And ensure power is supplied to extra servos with another power supply.

- Call the following setting screen by pushing the [S.BUS Servo] button in the System Menu.

- Select the function name and return to the System menu by pushing the RTN button or pushing the Home/Exit button.

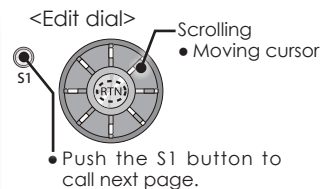
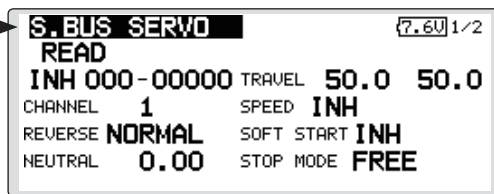

Procedure for changing S.BUS/S.BUS2 servo setting

1. Select [S.BUS Servo] of the System Menu.
2. Wire the servo as shown in the figure above.
3. Push [READ]. The ID and current setting of that servo are displayed.
4. When multiple servos are connected change [INH] at the right side of the ID number on the screen to [ACT] and enter the ID of the servo you want to set.
5. Set each item. (Please see the next page.)
6. Push [WRITE]. The settings are changed.

S.BUS Servo Description of function of each parameter

*There are some functions which can only be used with certain types of servos.

- **ID**

Displays the ID of the servo whose parameters are to be read. It cannot be changed.

- **Channel**

Channel of the S.BUS system is assigned to the servo. Always assign a channel before use.

- **Reverse**

The direction in which the servo rotates can be changed.

- **Servo type**

When "Retractable" is selected and the servo has been continuously stopped for 30 seconds, the dead band expands and unnecessary hold current due to external force is eliminated. When a new control signal enters, normal operation is resumed. When using the servo as a landing gear servo, select "Retractable". Also adjust the servo travel to match the landing gear movement range.

- **Soft Start**

Restricts operation in the specified direction the instant the power is turned on. By using this setting, the first initial movement when the power is turned on slowly moves the servo to the specified position.

- **Stop Mode**

The state of the servo when the servo input signal is lost can be specified. The "Hold" mode setting holds the servo in its last commanded position even if using AM or FM system.

- **Smoother**

This function changes smoothness of the servo operation relative to stick movement changes. Smooth setting is used for normal flight. Select the "OFF" mode when quick operation is necessary such as 3D.

- **Neutral Offset**

The neutral position can be changed. When the neutral offset is large value, the servo's range of travel is restricted on one side.

- **Speed Control**

Speeds can be matched by specifying the operating speed. The speed of multiple servos can be matched without being affected by motor fluctuations. This is effective for load torques below the maximum torque.

However, note that the maximum speed will not be exceed what the servo is capable of even if the servos operating voltage is increased.

- **Dead band**

The dead band angle at stopping can be specified.

[Relationship between dead band set value and servo operation]

Small → Dead band angle is small and the servo is immediately operated by a small signal change.

Large → Dead band angle is large and the servo does not operate at small signal changes.

(Note) If the dead band angle is too small, the servo will operate continuously and the current consumption will increase and the life of the servo will be shortened.

- **Travel Adjust**

The left and right travels centered about the neutral position can be set independently.

- **Boost**

The minimum current applied to the internal motor when starting the servo can be set. Since a small travel does not start the motor, it essentially feels like the dead band was expanded. The motor can be immediately started by adjusting the minimum current which can start the motor.

[Relationship between boost set value and servo operation]

Small → Motor reacts less to a change and operation becomes smooth.

Large → Initial response improves and output torque increases. However, if the torque is too large, operation will become rough.

• Boost ON/OFF

OFF : The boost turns ON at the time of lower-demand operation. (In most cases)

ON : The boost is always ON. (When quick operation is needed)

• Damper

The characteristic when the servo is stopped can be set.

When smaller than the standard value, the characteristic becomes an overshoot characteristic. If the value is larger than the standard value, the brake is applied before the stop position.

Especially, when a large load is applied, overshoot, etc. are suppressed by inertia and hunting may occur, depending on the conditions. If hunting (phenomena which cause the servo to oscillate) occurs even though the Dead Band, Stretcher, Boost and other parameters are suitable, adjust this parameter to a value larger than the initial value.

[Relationship between damper set value and servo operation]

Small → When you want to overshoot. Set so that hunting does not occur.

Large → When you want to operate so that braking is not applied. However, it will feel like the servo response has slowed down.

(Note) If used in the hunting state, not only will the current consumption increase, but the life of the servo will also be shortened.

• Stretcher

The servo hold characteristic can be set. The torque which attempts to return the servo to the target position when the current servo position has deviated from the target position can be adjusted.

This is used when stopping hunting, etc., but the holding characteristic changes as shown below.

[Relationship between stretcher and servo operation]

Small → Servo holding force becomes weaker.

Large → Servo holding force becomes stronger.

(Note) When this parameter is large, the current consumption increases.

• Buzzer

When the power supply of a servo is interrupted or a loss of signal from the transmitter, the buzzer sound of about 2.5Hz continues sounding from a servo.

(Even when the signal output of a transmitter is lost, a buzzer becomes until the signal of a servo is outputted normally.)

The transmitter has been turned OFF ahead of a servo power supply → The buzzer sound of about 1.25 Hz continues sounding to show that the servo power supply is still turned on.

(Do not insert or remove the servo connector while the receiver power is ON. A buzzer may sound by incorrect recognition.)

*Buzzer sound is generated by vibrating the motor of a servo.

Since a lot of current is consumed and a servo generates heat during buzzer sounds, please do not operate the feature more than needed or do not continue sounding a buzzer for a long time.

FUNCTIONS OF LINKAGE MENU

The Linkage Menu is made up of functions which perform model addition, model type selection, frequency setting, end point setting, and other model basic settings.

The functions which can be selected depend on the model type. A typical menu screen is shown below.

- Select [LINKAGE] at the home screen and call the linkage menu shown below by pushing the RTN button.
- Use the edit dial to select the function you want to set and call the setup screen by pushing the RTN button.

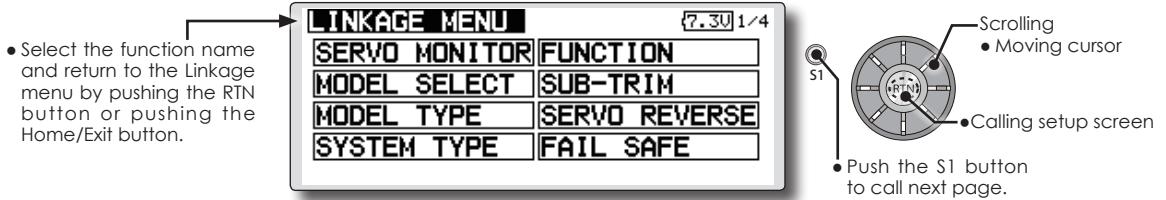

Linkage Menu functions table

[SERVO MONITOR]: Displays the servo test and operation position

[MODEL SELECT]: Model addition, call, deletion, copy, model name setting

[MODEL TYPE]: Model type, wing type, swash type, etc. selection

[SYSTEM TYPE]: System mode selection, link of a transmitter and receiver, area mode selection

[FUNCTION]: Channel assignment of each function can be changed

[SUB-TRIM]: Adjusts the neutral position of each servo

[SERVO-REVERSE]: Servo direction reversal

[FAIL SAFE]: Fail safe function and battery fail safe function setting

[END POINT]: Servo basic rudder adjustment and limit setting

[THROTTLE CUT]: Stops the engine safely and easily (airplane and helicopter only)

[IDLE DOWN]: Lowers the idle speed of the engine (airplane and helicopter only)

[TIMER]: Timer setting

[T1-T6 SETTING]: Control step amount and mode selection of the digital trim

[MULTIPROP]: CH is extended by MPDX-1 of an option

[FUNCTION NAME]: Function name can be changed

[TELEMETRY]: Displays various data sent from the receiver

[SENSOR]: Various telemetry sensors setting

[TELE.SETTING]: Various telemetry sensors setting

[WARNING]: Mixing warning normal reset

[TRAINER]: Starts and sets the trainer system.

[STICK ALARM]: Can be set so that an audible alarm sounds once when the throttle stick reaches the set position

[DATA RESET]: Model memory set data reset (by item)

SERVO MONITOR

Servo Test & Graph Display / Displays servo positions.

This is used for testing servo movement. “Moving Test” (repetition mode) and “Neutral Test” (fixed position mode) are available.

The “Neutral Test” is good for finding the neutral position of a servo horn.

In order to prevent any potential difficulties, the servo test function will be inoperable, or inaccessible, under certain conditions. Specifically, the Servo Test function is not operational if the Throttle Cut is ON in either airplane or helicopter modes; or if the Throttle Hold is ON in Helicopter mode.

- Select [SERVO MONITOR] at the linkage menu and call the setup screen shown below by pushing the RTN button.

- Select the function name and return to the Linkage menu by pushing the RTN button or pushing the Home/Exit button.

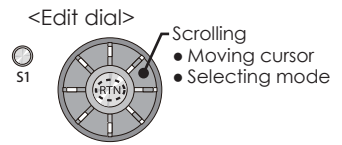
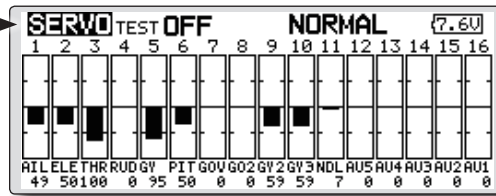

*The display screen is an example. The screen depends on the model type.

Servo test operation

1. Use the edit dial to move the cursor to the [TEST] item and push the RTN button to switch to the data input mode.

Select the test mode by turning the edit dial to the left or right and push the RTN button.

[MOVING]: Mode which repeats operation of each servo

[NEUTRAL]: Mode which locks each servo in the neutral position

2. Use the edit dial to move the cursor to the [TEST] item and push the RTN button to switch to the data input mode.

Select the [OFF] by turning the edit dial and push the RTN button. Testing is stopped.

⚠ WARNING

❗ Don't set a servo test mode when the drive motor is connected and the engine is powered or running.

■ Inadvertent rotation of the motor or acceleration of the engine is extremely dangerous.

MODEL SELECT

The Model Selection function performs model addition, call, deletion, copy, and model name setting.

This function is used to load the settings of the desired model into the FMT-03's memory.

The settings may be selected from either the transmitter's built-in memory or a micro SD card. Remember that up to 30 model memories are available in the transmitter.

The name of the model stored in the transmitter and the micro SD card may be changed. This can be very useful to tell different models settings apart. Each model name can be as long as 15 characters,

and the model name always appears in the display screen. The Copy function is used to copy one set of model data into a second memory within the transmitter and the micro SD card. It may be used for getting a head-start on setting up models with almost the same settings (only differences need to be modified, instead of entering the complete model from scratch). Also, this function may be used to make a backup copy of a model setup before any changes are made.

- Select [MODEL SELECT] at the linkage menu and call the setup screen shown below by pushing the RTN button.
- Select the function name and return to the Linkage menu by pushing the RTN button or pushing the Home/Exit button.

• "Save to"
[INTERNAL]: transmitter memory
[MEM.CARD]: Micro SD card

<Edit dial>
• Scrolling
• Moving cursor
• Selecting mode

(Model list)

*The display screen is an example. The screen depends on the model type.

Model call

*Model data saved at models other than the model currently used or saved on a Micro SD card can be called.

1. Use the edit dial to move to the save destination ("INTERNAL" or "MEM.CARD") and push the RTN button to switch to the data input mode.

Select the location which is to save the desired model by turning the edit dial to the left or right. Push the RTN button.

[INTERNAL]: Transmitter memory
[MEM. CARD]: Micro SD card

2. After using the edit dial to move the cursor to the desired model in the model list, push the RTN button.
3. Use the edit dial to move to [SELECT].
4. Push the RTN button. When a confirmation message is displayed and the RTN button is pushed again, calling is complete.

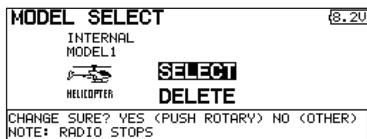

*Transmission stops and a send with new model confirmation message ("TRANSMIT?") appears.

5. To start transmission, use the edit dial to select [YES] and then push the RTN button. To not transmit, select [NO] and push the RTN button.

Model addition

*A new model can be added to the transmitter memory or Micro SD card.

1. Use the edit dial to move the cursor to the save destination ("INTERNAL" or "MEM. CARD") and push the RTN button to switch to the data input mode.

Select the save destination by turning the edit dial to the left or right. Push the RTN button.

[INTERNAL]: Transmitter memory
[MEM. CARD]: Micro SD card

2. Use the edit dial to move to [NEW].
3. Push the RTN button. A confirmation message appears. Push the RTN button again.

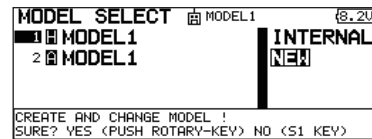

*The model type setup screen and frequency setup screen are automatically displayed. Confirm or change the model type and frequency.

*A starting transmission with new model confirmation message ("TRANSMIT") appears.

4. To start transmission, use the edit dial to select [YES] and then push the RTN button. To not transmit, select [NO] and push the RTN button.

*The added model appears in the model list.

Model deletion

*The model stored in the transmitter memory or a Micro SD card can be deleted.

*The current model can not be deleted.

1. Use the edit dial to move the cursor to the save destination display ("INTERNAL" or "MEM. CARD") and push the RTN button to switch to the data input mode.

Select the save destination by turning the edit dial to the left or right and push the RTN button.

[INTERNAL]: Transmitter memory

[MEM. CARD]: Micro SD card

2. Use the edit dial to move the cursor to the model you want to delete in the model list and then push the RTN button.
3. Move the cursor to [DELETE].
4. Push the RTN button. When a confirmation message is displayed and the RTN button is pushed again, the model is deleted.

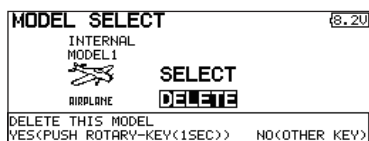

Model name change

*The current model's name can be changed.

1. Use the edit dial to select the current model in the model list and then push the RTN button.
2. Use the edit dial to move to [RENAME].
3. Push the RTN button.

*The model name setup screen is displayed.

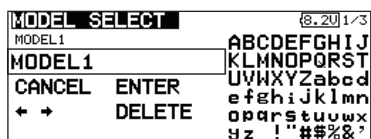

4. Change the model name as described below:

[Moving cursor in input box]

Select [←] or [→], and push the RTN button.

[Deleting a character]

When [DELETE] is selected and the RTN button is pushed, the character immediately after the cursor is deleted.

[Adding a character]

When a candidate character is selected from the character list and the RTN button is pushed, that character is added at the

position immediately after the cursor.

*A name of up to 8 characters long can be entered as the model name. (A space is also counted as 1 character.)

5. At the end of input, select [ENTER] and push the RTN button. (To terminate input and return to the original state, select [CANCEL] and push the RTN button.)

Model copy

*A copy can be made of the current model.

1. Use the edit dial to select the current model in the model list and then push the RTN button.
2. Move to [COPY] with the edit dial.
3. Push the RTN button.

*The copy screen appears.

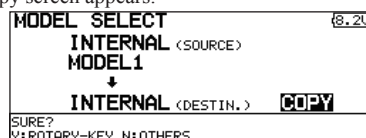

4. Use the edit dial to move to the copy destination position at the bottom of the screen and push the RTN button to switch to the data input mode.

Select the save destination by turning the edit dial and push the RTN button.

5. Use the edit dial to move to [COPY].
6. Push the RTN button. When a confirmation message is displayed and the RTN button is pushed again, the model data is copied.

*FMT-03 accepts a Micro SD card formatted FAT file system, but it does not support the long file name feature used in Windows or other modern operating systems. Thus FMT-03 can accept files whose name consists of only 8 characters or less. Furthermore, it supports only basic alphanumeric characters such as 'A' to 'Z', '0' to '9' and ' _ '.

MODEL TYPE

This function selects the model type from among multicopter, airplane, helicopter, and glider.

Seven types of main wings and three types of tail wings are available for airplanes. Eight swash types are available for helicopters. Seven types of main wings and three types of tail wings are available for gliders. Functions and mixing functions necessary for each model type are set in advance at the factory.

Note: The Model Type function automatically selects the appropriate output channels, control functions, and mixing functions for the chosen model type.

When the Model Type Selection command is accessed, all of the data in the active memory is cleared (except the following swash type.) Be sure that you don't mind losing this data, or back it up to another memory using the copying functions.

When you change the helicopter swash type within the following each group, you can leave the setting data other than the SWASH function. In this case, confirmation screen appears. However, it is initialized when you change the swash type exceeding the group.

- Select [MODEL TYPE] at the linkage menu and call the setup screen shown below by pushing the RTN button.

Swash type group A:
H-1, H-2, H-3, HR3, HN3, and HE3
Swash type group B:
H-4, H-4X

- Select the function name and return to the Linkage menu by pushing the RTN button or pushing the Home/Exit button.

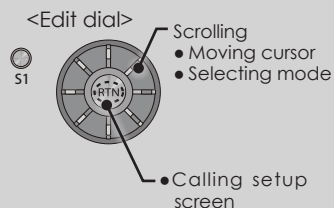
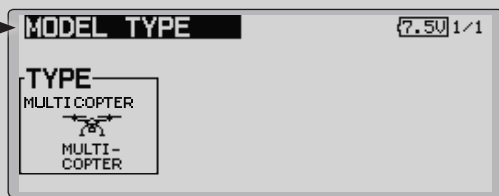

(The display screen is an example. The screen depends on the model type.)

Model type selection

1. Use the edit dial to move the cursor to the item you want to change and then call the selection screen by pushing the RTN button.

"TYPE": Model type

"WING" (airplane/glider): Wing type

"TAIL" (airplane/glider): Tail type

"SWASH" (helicopter): Swash type

2. Use the edit dial to move the cursor to the type you want to change and select the type by pushing the RTN button.

*When the model type was changed, the wing type, tail type, or swash type selection screens sequentially appear according to the model. Finally, the blinking confirmation message "MODEL TYPE CONFIRMATION" appears.

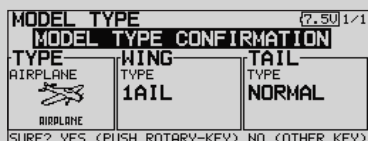

3. Push the RTN button to execute the change. (Operate the edit dial or S1 button to stop the change.)

*The model types which are displayed (which can be selected) depend on the type of receiver used. See Servo Connection by Model Type.

FMT-03 is equipped with a stick of multi-copter exclusive use. Therefore it's unsuitable for use of an airplane, a glider and a helicopter.

System Type selection

The FMT-03 is for 2.4GHz only. The system can be changed from among 2 choices: FASSTest 18CH and FASSTest 12CH which can be chosen by FMR-03 set.

- *If you change the System Type, other model data is not reset.
- *After any change, remember to test the model and should fully check servo direction and a motion.
- *Analog servos cannot be used with the FMR-03 in the FASSTest 12CH mode.

Dual receiver function (only FASSTest 18CH mode)

Dual receivers can be linked with the FMT-03. Two receivers are recognized individually by ID numbers. Two sets of receivers can be used as a set in the model. Separate fail-safe voltage can be set to each receiver.

However, telemetry cannot be used for the 2nd receiver.

- Select [SYSTEM] in the Linkage menu and access the setup screen shown below by pushing the RTN button.

- Select the function name and return to the Linkage menu by pushing the RTN button or pushing the Home/Exit button.

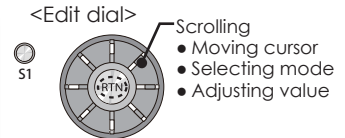

Receiver linking

The receiver will only be controlled (without being affected by other transmitters) by the transmitter it is linked to. When using a receiver other than one purchased as a set, linking is necessary.

Moreover, a re-link is required when a new model is added by model selection, and the time of system type change.

Cases when linking is necessary:

- When using a receiver other than the initial setting.
- When the communication system was changed. (FASSTest 18CH ↔ FASSTest 12CH etc.)
- When a new model was created by model selection.

Battery fail-safe voltage setup (only FASSTest mode)

The voltage which battery fail-safe activates, can be set when you link. (3.5-8.4V) The receiver memorizes the setting as it was at link.

Suggested setting voltages are as follows.

- 4 cells NiCd or NiMH (Normal: 4.8v) = 3.8 v
- 2 cells LiFe (Normal: 6.6 v) = 5.2 ~ 5.4 v
- 2 cells LiPo (Normal: 7.4 v) = 6.6 ~ 6.8 v

It is a rough reference value.

Since it changes with servos carried in the condition and the model of a battery, please set to your own model in a battery consumption current.

Linking method 

Telemetry function (FASSTest 18CH mode only)

To use the telemetry function, set “Telemetry” to “ACT”.

DL Interval (FASSTest 18CH mode only)

When a telemetry function is enabled, the receiving interval (down-link interval) of sensor data can be changed.

If a DL interval is increased, the response of the sensor data display becomes slower, but stick response will improve.

System Type selection procedure

1. Move the cursor to the [FASSTest-18CH] item and push the RTN button to switch to the data input mode.

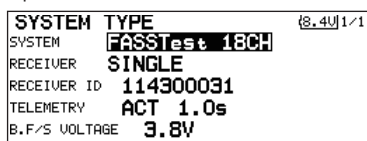

2. Select the system type by scrolling the edit dial.
[FASSTest 18CH][FASSTest 12CH]

*An example of selections for each system is on the following page.

3. Push the RTN button to end adjustment and return to the cursor mode.

Dual receiver function (only FASSTest 18CH mode) procedure

1. Move the cursor to the [SINGLE] item and push the RTN button to switch to the data input mode.

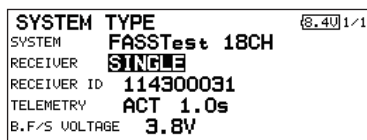

2. Select the [SINGLE] or [DUAL] by scrolling the edit dial.

ID of a Primary receiver displays.

ID of a Secondary receiver displays.

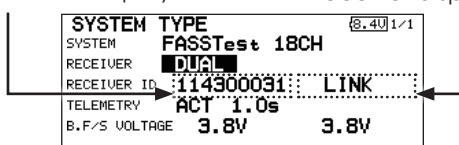

In DUAL, a primary receiver is link previously. Next, a secondary receiver is link.

3. Push the RTN button to end adjustment and return to the cursor mode.

Telemetry ACT/INH procedure

1. Move the cursor to the TELEMETRY [ACT] item and push the RTN button to switch to the data input mode.

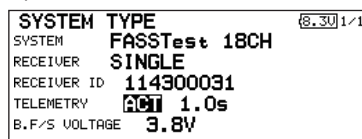

2. Select the [ACT] or [INH] by scrolling the edit dial.
3. Push the RTN button to end adjustment and return to the cursor mode.

DL Interval set procedure

1. Move the cursor to the TELEMETRY DL [1.0s] item and push the RTN button to switch to the data input mode.

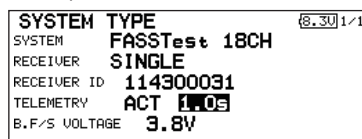

2. Select the DL time by scrolling the edit dial.
If a DL interval is increased, the response of the sensor data display becomes slower, but stick response will improve.

Initial value: 1.0s

Adjustment range : 0.1s~2.0s

3. Push the RTN button to end adjustment and return to the cursor mode.

FUNCTION

Channel assignment of each function can be changed.

When you select model and wing (swash) types, you will find that the optimized combinations of servo output channels and functions have been already preset. If you would like, you can freely change combinations of servo output channels, functions (aileron, elevator, etc), and control (sticks, switches, and trim levers).

*You can also assign the same function to multiple servo output channels such as assigning elevator function to CH2 and CH3.

Channel Replacement

When the channel is replaced in the function menu, replaced channel uses the setting data (End point, SUB-TRIM, REVERSE, F/S, and B-F/S, etc.).

Servo Output Channels

For FASSTest 12CH mode, you can set 12 linear channels and two digital channels. For FASSTest 18CH mode, you can set 16 linear channels and two digital channels.

*DG1/2 (digital channels)

These channels can function as switched channels. You can freely change combinations between servo output channels and input controls (sticks, switches, and trim levers).

Motor Function

If you have either a glider or airplane model type selected, and choose to activate the motor function, a reverse setting screen is displayed.

*If "YES" is selected, the output is reversed. If "NO" is selected, the output is normal.

• Select [FUNCTION] at the linkage menu and call the setup screen shown below by pushing the RTN button.

• Select the function name and return to the Linkage menu by pushing the RTN button or pushing the Home/Exit button.

CH	FUNCTION	CONTROL	TRIM	1/5
1	AILERON	J1	T1	SEPAR
2	ELEVATOR	J3	T3	SEPAR
3	THROTTLE	J2	T2	SEPAR
4	RUDDER	J4	T4	SEPAR

(The display screen is an example. The screen depends on the model type.)

• Trim operation mode
 "COMB": Combination mode
 "SEPAR": Separate mode

<Edit dial>

- Scrolling
- Moving cursor
- Selecting mode

• Push the S1 button to call next page.

Function change

1. Use the edit dial to move the cursor to the "FUNCTION" item of the channel you want to change and push the RTN button.

*The function selection screen is displayed.

2. Use the edit dial to move the cursor to the function name you want to set and push the RTN button.

*The function name blinks.

3. Push the RTN button to execute the change. (When you want to cancel this operation, operate the edit dial or S1 button.)

*Multiple channels can be assigned to one function.

Operation control change

1. Use the edit dial to move the cursor to the "CONTROL" item of the channel you want to change and push the RTN button.

*The control selection screen is displayed.

HARDWARE SEL.	CONDIT1	6.6U	1/1
HARDWARE LIST			
J1	SA	SE	J6 DA T3 --
J2	SB	SF	J5 DB T4
J3	SC	SG	DC T1 T5
J4	SD	SH	DD T2 T6

2. Use the edit dial to move the cursor to the control you want to change, and push the RTN button.

*The same control can be assigned to multiple channels.

*The setting can be changed for each condition.

After the set mode is changed from group mode [G] to single mode [S] at the control selection screen, only that condition setting is changed by control change; setting of other conditions remains the same.

Trim setting

Use the edit dial to move the cursor to the "TRIM" item of the channel you want to change and push the RTN button.

*The trim setup screen is displayed.

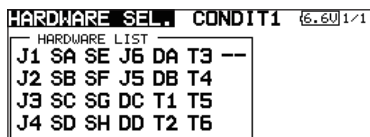

The following items can be set at the trim setup screen:

*The setting can be changed for each condition.

After the set mode is changed from group mode [G] to single mode [S] at the control selection screen, only that condition setting is changed by control change; setting of other conditions remains the same.

Trim selection

Use the edit dial to move the cursor to the trim, lever, etc. you want to set and push the RTN button.

*The setting can be changed.

Trim rate setting

Use the edit dial to move the cursor to the [RATE] item and push the RTN button to switch to the data input mode.

Set the trim rate by turning the edit dial.

Initial value: +30%

Adjustment range : 0~150%

(When the RTN button is pushed for 1 second, the trim rate is reset to the initial value.)

Push the RTN button to end adjustment and return to the cursor move mode.

Trim mode selection

Use the edit dial to move the cursor to the [TRIM MODE] item and select the trim mode by turning the edit dial.

[NORM]: Normal mode. Normal trim (parallel shift trim) operation.

[ATL]: ATL operation mode. Maximum change near center by operation normally used with throttle trim. Reverse is also possible.

[NORM]/[REV] selection is possible at the "ATL REV" item.

[CENTER]: Maximum change near center by center trim operation.

⚠ WARNING

❗ As a safety precaution to prevent the motor from starting unexpectedly, please switch off the motor accordingly. We also suggest removing the propeller from the motor as an additional precaution.

SUB-TRIM

Setting of neutral position of each servo.

The Sub-Trim function is used to set the servo neutral position, and may be used to make fine adjustments to the control surface after linkages and pushrods are hooked up. When you begin to set up a model, be sure that the digital trims are set to their center position.

- Select [SUB-TRIM] at the linkage menu and call the setup screen shown below by pushing the RTN button.

- Select the function name and return to the Linkage menu by pushing the RTN button or pushing the Home/Exit button.

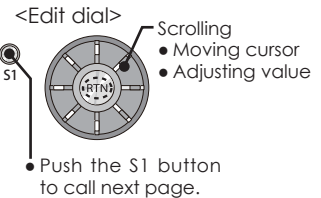
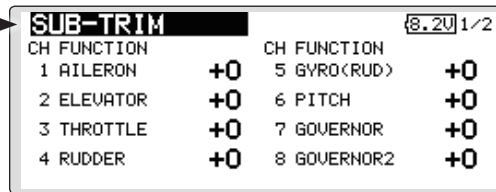

(The display screen is an example. The screen depends on the model type.)

Sub trim adjustment

1. Use the edit dial to move the cursor to the channel you want to adjust and push the RTN button to switch to the data input mode.

2. Adjust by turning the edit dial.

Initial value: 0

Adjustment range: -240~+240 (steps)

(When the RTN button is pushed for 1 second, sub trim is reset to the initial value.)

*Before sub trim adjustment, adjustment of the linkage so that control surfaces need not use sub trim as much as possible is very important.

3. Repeat this procedure for each channel.

SERVO-REVERSE

Use to reverse the throw direction.

Servo Reverse changes the direction of an individual servo's response to a control stick movement.

For CCPM helicopters, be sure to read the section on Swash AFR before reversing any servos. With CCPM helicopters, always complete your servo reversing prior to any other programming. If you use pre-built Airplane/Sailplane functions

that control multiple servos, it may be confusing to tell whether the servo needs to be reversed or a setting in the function needs to be reversed. See the instructions for each specialized function for further details. Always check servo direction prior to every flight as an additional precaution to confirm proper model memory, hook ups, and radio function.

- Select [SERVO REVERSE] at the linkage menu and call the setup screen shown below by pushing the RTN button.

- Select the function name and return to the Linkage menu by pushing the RTN button or pushing the Home/Exit button.

SERVO REVERSE						(8.20) 1/3
CH	FUNCTION	MODE	CH	FUNCTION	MODE	
1	AILERON	NORM	5	GYRO<RUD>	NORM	
2	ELEVATOR	NORM	6	PITCH	NORM	
3	THROTTLE	NORM	7	GOVERNOR	NORM	
4	RUDDER	NORM	8	GOVERNOR2	NORM	

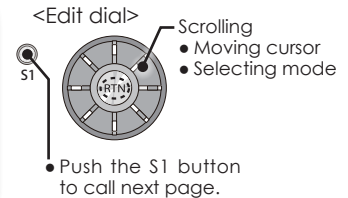

(The display screen is an example. The screen depends on the model type.)

Servo reversing procedure

- *After linkage of a new model is complete, check whether or not each servo is connected to the correct channel.
 - *Next, determine whether you need to reverse any channels by moving each stick.
1. Use the edit dial to move the cursor to the channel you want to reverse and push the RTN button to switch to the data input mode.
 2. Turn the edit dial and change the display to [REVERSE] (or [NORMAL]).
 - *The display blinks.
 3. When the RTN button is pushed, servo operation is reversed. (Operate edit dial or S1 button to stop reversal.)
 - *Repeat the operation above for each channel that must be reversed.

FAIL SAFE

Sets the servos operating position when transmitter signals can no longer be received or when the receiver battery voltage drops.

The Failsafe function may be used to set up positions that the servos move to in the case of radio interference.

You may set either of two positions for each channel: Hold, where the servo maintains its last commanded position, or Failsafe, where each servo moves to a predetermined position. You may choose either mode for each channel.

The FMT-03 system also provides you with an advanced battery monitoring function that warns you when the receiver battery has only a little power remaining. In this case, each servo is moved to the defined failsafe position. The battery failsafe may be released by operating a predefined control on the transmitter, do not continue to fly, land as soon as possible. Remember, if the predefined control suddenly moves to a position you did not command, land at once and check your receiver

battery.

Defines servo position when signals are lost and when receiver battery voltage becomes low.

⚠ WARNING

❗ For safety, always set the fail safe functions.

- Remember to set the throttle channel fail safe function so that the servo moves to the maximum slow side for airplanes and to the slow side from the hovering position for helicopters. Crashing of the model at full high when normal radio waves cannot be received due to interference, etc., is very dangerous.
- If the battery fail safe is reset by the throttle stick, it may be mistaken for an engine malfunction and will be reset at throttle slow and the model will continue to fly. If you have any doubts, immediately land.

- Select [FAIL SAFE] at the linkage menu and call the setup screen shown below by pushing the RTN button.

(The display screen is an example. The screen depends on the model type.)

- Select the function name and return to the Linkage menu by pushing the RTN button or pushing the Home/Exit button.

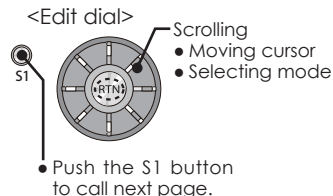
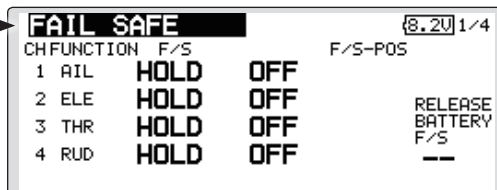

Fail safe setting procedure

1. Move the cursor to the "F/S" item of the channel you want to set and push the RTN button to switch to the data input mode.
2. Select the F/S mode by scrolling the edit dial. A confirmation message appears.
*The display blinks.
3. Push the RTN button. (Push the S1 button to stop setting.)
*The channel switches to the F/S mode.
4. Move the cursor to the "POS" item.

Hold the corresponding stick, knob, slider, etc. in the position you want the servo to move to when the fail safe function is activated and push the RTN button for one second.

*The set position is displayed in percentage.

*If you want to return that channel to the hold mode, move the cursor to the "F/S" item and push the RTN button to switch to the data input mode. Select the F/S mode by scrolling the edit dial. A confirmation message appears and then change the mode by pushing the RTN button.

Battery fail safe setting procedure

Battery fail safe can be set for each channel by the same method as the fail safe setting procedure. Select and set the "B.F/S" item.

[ON]: Battery fail safe function ON

[OFF]: Battery fail safe function OFF

Battery fail safe release switch setting

This function temporarily releases the battery fail safe function, so the model can recover after the battery fail safe function was activated by a drop in the receiver battery voltage. This setting selects the switch which releases the battery fail safe function.

1. Move the cursor to the [RELEASE B.F/S] item in the setup screen (last page).
2. Push the RTN button.

*The switch selection screen is called.

*For a detailed description of the switch selection and ON/OFF direction setting method, see [Switch Setting Method] at the back of this manual.

END POINT

Sets the travel, limit point, and speed of each servo.

The End Point function adjusts the left and right servo throws, generates differential throws, and will correct improper linkage settings.

The travel rate can be varied from 30% to 140% in each direction on channels 1 to 12. Also, the limit point where servo throw stops may be varied from 0% to 155%.

NOTE: The servo speed setting is used to set the servo delay for each channel, from channel 1 to channel 12. The system uses the programmed speed (delay) to slow down servo position changes. The servo speed setting can be varied from 0 to 27 in each channel.

- Select [END POINT] at the linkage menu and call the setup screen shown below by pushing the RTN button.

- Select the function name and return to the Linkage menu by pushing the RTN button or pushing the Home/Exit button.

CH FUNCTION	LIMIT	TRAV.	TRAV.	LIMIT SPEED
1 AILERON	135%	100%	100%	135% 0
2 ELEVATOR	135%	100%	100%	135% 0
3 THROTTLE	135%	100%	100%	135% 0
4 RUDDER	135%	100%	100%	135% 0

(The display screen is an example. The screen depends on the model type.)

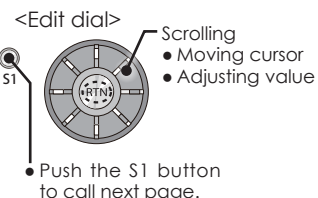

Servo travel adjustment

1. Use the edit dial to move the cursor to the "TRAV." item of the channel you want to adjust and push the RTN button to switch to the data input mode.
2. Turn the edit dial to adjust the rate.
Initial value: 100%
Adjustment range: 30%~140%
(When the RTN button is pushed for 1 second, the rate is reset to the initial value.)
Push the RTN button to end adjustment and return to the cursor move mode.
3. Repeat this procedure for each rate.

Limit point adjustment

1. Use the edit dial to move the cursor to the "LIMIT" item of the channel you want to adjust and push the RTN button to switch to the data input mode.
2. Turn the edit dial to adjust the limit point.
Initial value: 135%
Adjustment range: 0%~155%
(When the RTN button is pushed for 1 second, the limit point is reset to the initial value.)
Push the RTN button to end adjustment and return to the cursor move mode.
3. Repeat this procedure for each limit point.

Servo speed setting

1. Use the edit dial to move the cursor to the "SPEED" item of the channel you want to adjust and push the RTN button to switch to the data input mode.
2. Turn the edit dial to adjust the servo speed.
Initial value: 0
Adjustment range: 0~27 (steps)
(When the RTN button is pushed for 1 second, the servo speed is reset to the initial value.)
Push the RTN button to end adjustment and return to the cursor move mode.
3. Repeat this procedure for each channel.

THROTTLE CUT

Stops the engine safely and easily. (Airplane and helicopter only)

Throttle cut provides an easy way to stop the engine, by flipping a switch with the throttle stick at idle. The action is not functional at high throttle to avoid accidental dead sticks. The switch's location and direction must be chosen, as it defaults to NULL.

- Select [THROTTLE CUT] at the linkage menu and call the setup screen shown below by pushing the RTN button.

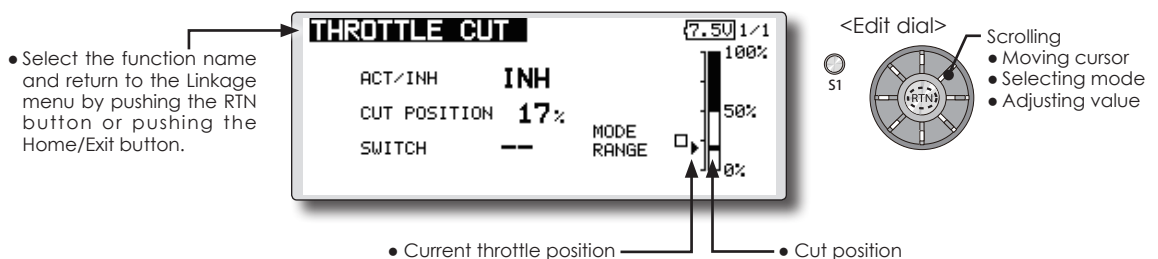

Throttle cut setting procedure

*Perform the following settings before using the edit dial to move the cursor to the item to be set.

1. Activate the function:

Move the cursor to the [ACT/INH] item and push the RTN button to switch to the data input mode.

Turn the edit dial to the left until the blinking changes from "INH" to "ACT" and then push the RTN button.

2. Switch setting:

Move the cursor to the [SWITCH] item and call the switch setup screen by Pushing the RTN button and select the switch and ON direction.

(For a detailed description of the setting method, see [Switch Setting Method] at the back of this manual.)

3. Throttle cut position setting:

Move the cursor to the [CUT POSITION] item and push the RTN button to switch to the data input mode.

Adjust the servo operation position at throttle cut operation by turning the edit dial to the left or right.

Initial value: 17%

Adjustment range: 0%~50%

(When the RTN button is Pushed for 1 second, the servo operation position is reset to the initial value.)

Push the RTN button to end adjustment and return to the cursor move mode.

*With the selected cut switch ON and the throttle stick at idle; adjust the rate until the engine consistently cuts off.

However, be sure that the throttle linkage is not pulled too tight and unreasonable force is not applied to the servo.

IDLE DOWN

Lowers the engine idling speed. (Airplane and helicopter only)

The Idle Down function lowers the engines idle by flipping a switch with the throttle stick at idle. The action is not functional at high throttle to avoid accidental dead sticks. The switch's location and direction must be chosen, as it defaults to NULL.

- Select [IDLE DOWN] at the linkage menu and call the setup screen shown below by pushing the RTN button.

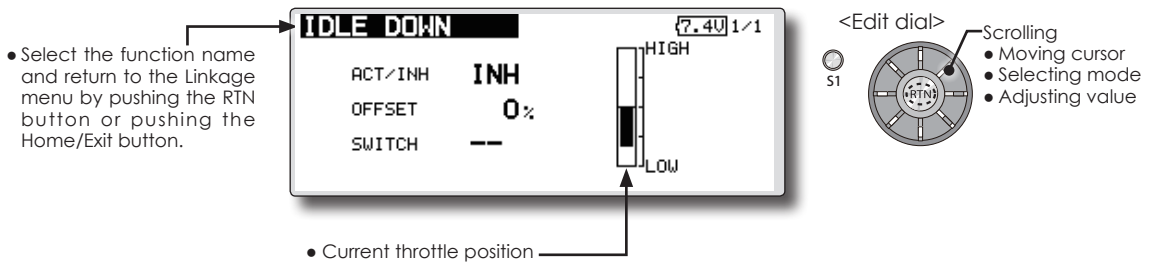

Idle down setting procedure

*Perform the following settings after using the edit dial to move the cursor to the item you want to set.

1. Activate the function:

Move the cursor to the [ACT/INH] item and push the RTN button to switch to the data input mode.

Switch the blinking from "INH" to "ACT" by turning the edit dial to the left and then push the RTN button.

2. Switch setting:

Move the cursor to the [SWITCH] item, call the switch setup screen by pushing the RTN button, and select the switch and ON direction.

(For a detailed description of the setting method, see [Switch Setting Method] at the back of this manual.)

3. Offset rate setting:

Move the cursor to the [OFFSET] item and push the RTN button to switch to the data input mode.

Adjust the servo offset rate at idle down operation by turning the edit dial to the left or right.

Initial value: 0%

Adjustment range: -100%~100%

(When the RTN button is pushed for 1 second, the offset rate is reset to the initial value.)

*Maximum offset amount is near maximum slow.

*When a minus rate is input, offset is applied to the high side.

Push the RTN button to end adjustment and return to the cursor move mode.

The Timer function may be set for any desired time, i.e. engine run time, specified times for competitions, etc. Two independent timers are provided for your use. The timers are stored independently with each model, meaning that when you switch between model setups, the timer associated with the new model is brought up automatically.

The timers may be set to start and stop from the motion of any switch or stick. You may set the ON and OFF directions freely. Each timer has a capacity of up to 59 minutes 59 seconds.

Each timer may be set for count-down or count up operation with a target time.

If a target time is set and the timer reaches the set time, a buzzer sound for each count is generated.

Countdown timers sound one short beep during the last twenty seconds and two short beeps during the last ten seconds before reaching the target, then a long tone at the target time, and continue counting with displaying a minus (-) sign. Count-up timers also beep the last twenty and ten seconds, beep the target time, and keep counting upwards until shut down.

- Select [TIMER] at the linkage menu and call the setup screen shown below by pushing the RTN button.

- Select the function name and return to the Linkage menu by pushing the RTN button or pushing the Home/Exit button.

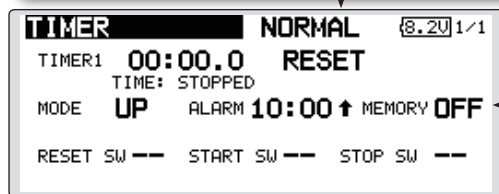
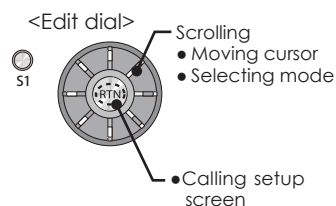
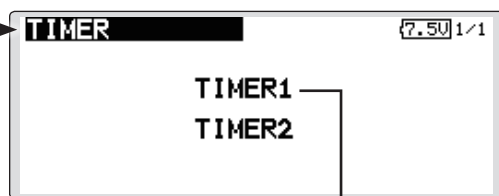

Memory → ON

- The timer value is held even if the power is turned off or the model is switched.

Timer setting

*Perform the following settings after using the edit dial to move the cursor to the item you want to set.

1. Up timer/down timer setting

Move the cursor to the [MODE] item and push the RTN button to switch to the data input mode.

Select the mode by moving the edit dial to the left or right and push the RTN button.

[UP]: Up timer

[DOWN]: Down timer

2. Timer time setting

Move the cursor to the [10]:[100] item and push the RTN button to switch to the data input mode.

Set the time by turning the edit dial to the left or right.

[00]:[00]:[min]:[sec]

Push the RTN button to end adjustment and

return to the cursor move mode.

3. Switch setting

Move the cursor to the item of the switch you want to set, call the switch setup screen by pushing the RTN button, and select the switch and ON direction.

[For a detailed description of the setting method, see [Switch Setting Method] at the back of this manual.]

[RESET SW]: Reset switch

[START SW]: Start switch

[STOP SW]: Stop switch

Timer operation

- Timer 1 and Timer 2 are started/stopped by pre-selected start/stop switch.
- To reset a timer, operate the pre-selected reset switch, or move the cursor to the [RESET] display on the timer screen and push the RTN button.

Alarm mode

*A mode which sounds an alarm every minute during the remaining time up to the timer alarm time.

1. Change the setting by Pushing ↑ or ↓ button.

[↑]: An alarm sounds every minute of the elapsed time from timer start. (Conventional mode)

[↓]: An alarm sounds every minute of the remaining time up to the alarm time.

HOURL mode

*An HOUR mode counts up to 99 hours 50 minutes to the timer modes.

- This mode is convenient when used at engine maintenance period and other long term measurements.
- When the HOUR mode is set, "xx(hour) : xx(minute)" is displayed on the count time display. Seconds are not displayed.
- When the HOUR mode is set, " : " blinks each second during timer operation.
- When the HOUR mode is set, the alarm function/lap time measurement function are inhibited.

T1-T6 SETTING

Digital trim settings

This function adjusts the digital trim's control step amount and operation mode (T1-T6).

When the flight conditions are set, the trim operation can be coupled with among all the conditions which combination mode is selected.

Trim lever T1-T6 isn't equipped in FMT-03.

- Select [T1-T6 SETTING] at the linkage menu and call the setup screen shown below by pushing the RTN button.

- Select the function name and return to the Linkage menu by pushing the RTN button or pushing the Home/Exit button.

T1-T6 SETTING			CONDIT1			6.90	1/1
	POS	STEP MODE		POS	STEP MODE		
T1	+0	4 C	T4	+0	4 C		
T2	+0	4 C	T5	+0	4 C		TRIM UNIT
T3	+0	4 C	T6	+0	4 C		--

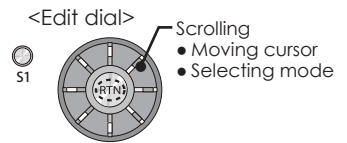

Trim position setting (neutral offset)

1. Use the edit dial to move the cursor to the [POS] item and push the RTN button to switch to the data input mode.
Set the trim position by turning the edit dial.
Initial value: +0 (neutral position)
(When the RTN button is pushed for 1 second, the control step amount is reset to the initial value.)
2. Push the RTN button to end adjustment and return to the cursor move mode.

Control step amount setting

1. Use the edit dial to move the cursor to the [STEP] item and push the RTN button to switch to the data input mode.
Set the control step amount by turning the edit dial.
Initial value: 4
Adjustment range: 0(trim off)-200
(When the RTN button is pushed for 1 second, the control step amount is reset to the initial value.)
*When the value is made large, the change per step becomes larger.
2. Push the RTN button to end adjustment and return to the cursor move mode.

C; combination / S; separate mode selection

1. Use the edit dial to move the cursor to the [C;COMB./S;SEPA.] item and change to blinking by turning the edit dial and select the mode by pushing the RTN button.
[C;COMB]: Combination mode. The trim data are reflected at all the flight conditions.
[S;SEPA]: Separate mode. Trim adjustment for each flight condition.

Trim display units

- Percentage(%) display can be selected at trim.
1. Select "TRIM UNIT" and turn the dial and switch the display to [%] or [--].
*The display blinks.
[%]: Trim is displayed in % units.
[--]: Trim is displayed numerically as in the past.
 2. When the RTN button pushed, the setting is changed.

The system has compatible with the Futaba MPDX-1 multiprop decoder. One channel can be expanded to 8 channels by using the MPDX-1 multiprop decoder. Up to two MPDX-1 can be used.

*The trim step amount and trim rate are not reset.

- Select [MULTIPROP] at the linkage menu and call the setup screen shown below by pushing the RTN button.

- Select the function name and return to the Linkage menu by pushing the RTN button or pushing the Home/Exit button.

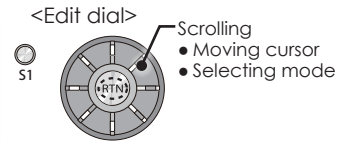

Multiprop selection

1. Select the Linkage Menu multiprop setting [MULTIPROP] and push the RTN button.
2. The MULTIPROP setup screen is displayed.
3. Select [MP1] and push the RTN button.
4. Scrolling the edit dial and switch the display to [MP1] or [MP2].
*The display blinks.
[MP1]: Multiprop 1
[MP2]: Multiprop 2
5. Push the RTN button.

Channel setting

1. Select [CH] and push the RTN button. Scrolling the edit dial and display the channel to which the MPDX-1 is connected.
*To turn off the multiprop function, set [--] at CH.
2. When the activated channel is selected and push the RTN button, the multiprop setting contents are displayed.

Control setting

1. Select the "CONTROL" row of the multiprop channel whose control you want to set and push the RTN button.
2. A hardware selection screen is displayed. Select the hardware which is to set control and push the RTN button.

Servo reverse setting

1. Select the "REVERSE" row of the multiprop channel which is to be reversed and push the RTN button.
2. Scrolling the edit dial and switch the display to [NORM] or [REV].
*The display blinks.
[NORM]: Normal mode
[REV]: Reverse mode
3. Push the RTN button.

End Point Setting

1. Select the "← ↑" row or "↓ →" row of the multiprop channel whose end point is to be set and switch to the data input mode by push the RTN button.
2. Adjust the end point by scrolling the edit dial.
Initial value : 100%
Adjustment range : 30-100%
3. After adjustment, push the RTN button.

FUNCTION NAME

Function name can be changed

The name of the spare functions (AUXILIARY1-8) can be changed for the full name (10 characters) or for the abbreviated name (4 characters).

- Select [FUNCTION NAME] at the linkage menu and call the setup screen shown below by pushing the RTN button.

• Select the function name and return to the Linkage menu by pushing the RTN button or pushing the Home/Exit button.

<Edit dial>

- Scrolling
- Moving cursor

• Push the S1 button to call next page.

Function name change method

1. Select [FUNCTION NAME] of the Linkage Menu and push the RTN button.
2. The FUNCTION NAME setup screen is displayed.
3. When the function whose name is to be changed is selected and the RTN button is pushed, a modification screen is displayed.
4. Select the function to be renamed and select [RENAME] and push the RTN button. A character input screen is displayed. Input the function name.

FUNCTION NAME (7.5U) 1/2

10 CHARACTERS: AUXILIARY1

RENAME

RESET

DEFAULT: AUXILIARY1

RESET: TOUCH RTN BUTTON (1 SEC)

6. The function name may be displayed in 10 characters or 4 characters, depending on the setup screen. For 4 characters, display, input the function name as required.

FUNCTION NAME (7.5U) 1/1

10 CHARACTERS: AUXILIARY1

RENAME

RESET

10 CHARACTERS: AUXILIARY1

FUNCTION NAME (7.5U) 1/3

AUXILIARY1

AUXILIARY1

CANCEL ENTER

+ + DELETE

ABCDEFGHIJ
KLMNOPQRST
UVWXYZabcd
efghijklmn
opqrstuwx
yz !"#%&?

FUNCTION NAME (7.5U) 1/2

4 CHARACTERS: AUX1

1 AUXILIARY1 AUX1

2 AUXILIARY2 AUX2

3 AUXILIARY3 AUX3

4 AUXILIARY4 AUX4

DEFAULT: AUX1

5. When [RESET] is selected and the RTN button is held down, the function name is set to the initial state function name.