

## FLAP SETTING

[Corresponding model type]: Airplane/  
glider, 2 flaps or more]

The up/down travel of each flap (camber flaps: FLP1/2, brake flaps: FLP3/4) can be adjusted independently at each servo according to the wing type.

- The operation reference point of each flap can be offset

The camber flaps of a 4-flap model can be mixed with the brake flaps. (Brake FLP to camber FLP)

- An ON/OFF switch can be set.

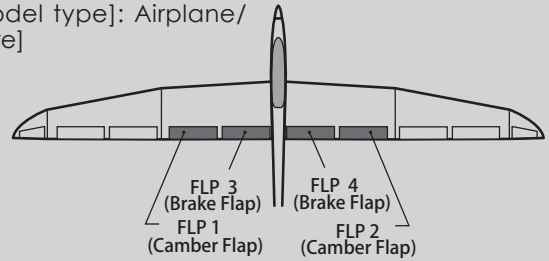

### <Wing type: 4 flaps screen>

\*The display screen is an example. The actual screen depends on the model type.

- Select [FLAP SETTING] at the model menu and call the setup screen shown below by pushing the RTN button.

(CAMBER FLP setting screen)

FLAP SETTING		CONDIT1	7.50	1/3
CAMBER FLAP		INH		
	FLAP	FLP2		
UP	+100%	+100%		
DOWN	+100%	+100%	GROUP	GROUP
OFFSET	+0%	+0%		

- Select the function name and return to the preceding screen by pushing the RTN button or pushing the Home/Exit button.

<Edit dial>

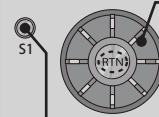

Scrolling

- Moving cursor
- Selecting mode
- Adjusting value

- Push the S1 button to call next page.

(BRAKE FLP setting screen)

FLAP SETTING		CONDIT1	7.50	2/3
BRAKE FLAP		INH		
	FLP3	FLP4		
UP	+100%	+100%		
DOWN	+100%	+100%	GROUP	GROUP
OFFSET	+0%	+0%		

- Up side/Down side adjustment

- Operation reference point offset

- Group/single mode switching

(For more information, refer to the description at the back of this manual.)

(B.FLP to C.FLP setting screen)

FLAP SETTING		CONDIT1	7.50	3/3
BRAKE FLAP → CAMBER FLAP				
UP	+100%	ACT/INH	INH	
DOWN	+100%	GROUP	GROUP	
OFFSET	+0%	SWITCH	--	

### Setting method

- Move the cursor to the flap (FLP) 1~4 up or down item according to the wing type and push the RTN button to switch to the data input mode.

Adjust the travel independently.

- To offset the operation reference point of each flap, move the cursor to the corresponding offset item. Use the edit dial to offset the reference point.

Push the RTN button to end adjustment and return to the cursor move mode.

- When using brake FLP to camber FLP mixing, move the cursor to the [ACT/INH] item and turn the edit dial to the left and push the RTN button. (ON is displayed.)

When setting a switch, move the cursor to the [--] item of the switch and push the RTN button to call the selection screen, and then select the switch and set its ON direction. (Always ON at "--" setting)

(For a description of the switch selection method, see the description at the back of this manual.)

## AIL to CAMB.FLP [Corresponding model type]: Airplane/ glider, 2 ailerons + 2 flaps or more

This mix operates the camber flaps (FLP1/2) in the aileron mode. When the aileron stick is manipulated, the ailerons and camber flaps perform aileron operation simultaneously and the operation characteristic of the roll axis is improved.

- The aileron left/right mixing rate of each flap servo can be fine-tuned.
- A mixing curve can be set.
- An ON/OFF switch can be set.
- Linking is possible: Link this mix to other mixes.

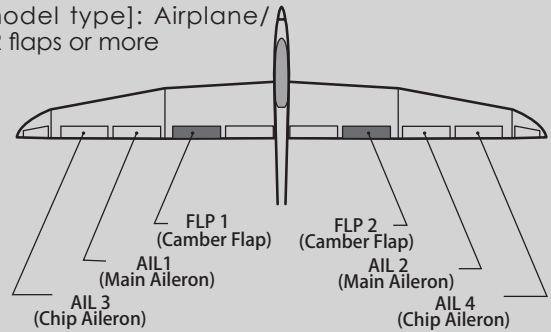

\*The display screen is an example. The actual screen depends on the model type.

- Select [AIL to CAMB.FLP] at the model menu and call the setup screen shown below by pushing the RTN button.

- Select the function name and return to the preceding screen by pushing the RTN button or pushing the Home/Exit button.

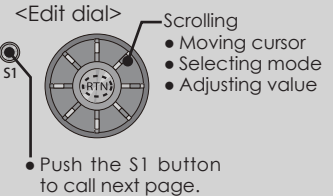
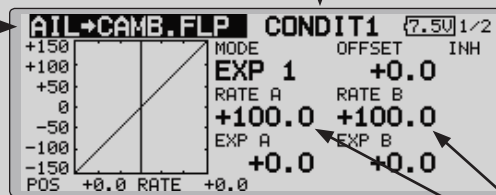

- Mixing curve setting  
\*For a description of the curve setting method, see the description at the back of this manual.

- Group/single mode switching

(For more information, refer to the description at the back of this manual.)

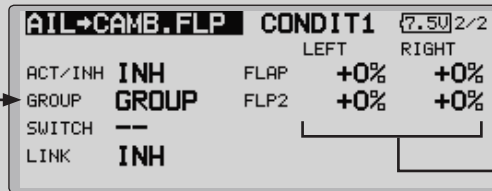

- Left/right overall adjustment at Rate A and Rate B

- Adjustment of each flap servo

### Setting method

- Move the cursor to the ACT/INH item and push the RTN button to switch to the data input mode.

Turn the edit dial to the left and push the RTN button. (ON is displayed.)

- When setting a switch, move the cursor to the [--] item of the switch and push the RTN button to call the selection screen, and then select the switch and set its ON direction. (Always ON at "--" setting)

(For a description of the switch selection method, see the description at the back of this manual.)

- Move the cursor to the left or right item of each flap servo and push the RTN button to

switch to the data input mode.

Adjust the mixing rate with the edit dial.

Push the RTN button to end adjustment and return to the cursor move mode.

\*When the mixing direction is reversed by the linkage, adjustments can be made by changing the mixing rate polarity (+ or -).

- A mixing curve can be set.

(For a description of the mixing curve setting method, see the description at the back of this manual.)

- To set linking, move the cursor to the [LINK] item and push the RTN button to switch to the data input mode.

Set it to ON and push the RTN button.

## AIL to BRAKEFLP [Corresponding model type]: Airplane/ glider, 4 flaps or more

This mix operates the brake flaps (FLP3/4) in the aileron mode. When the aileron stick is manipulated, the aileron and brake flaps perform the aileron operation simultaneously and the operation characteristic of the roll axis is improved.

- The aileron left and right mixing rates can be adjusted for each flap servo.
- A mixing curve can be set.
- Mixing during flight can be turned ON/OFF by setting a switch. (Always ON at [-] setting)
- Linking can be set: Link this mix to other mixes.

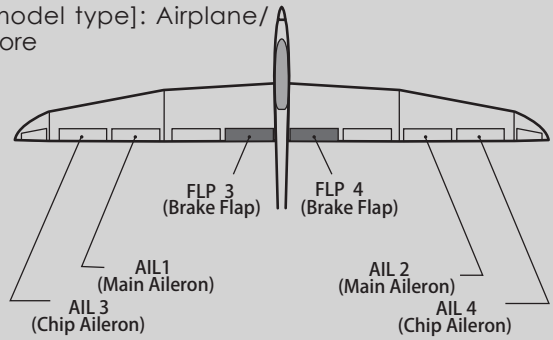

\*The display screen is an example. The actual screen depends on the model type.

- Select [AIL to BRAKEFLP] at the model menu and call the setup screen shown below by pushing the RTN button.

- Select the function name and return to the preceding screen by pushing the RTN button or pushing the Home/Exit button.

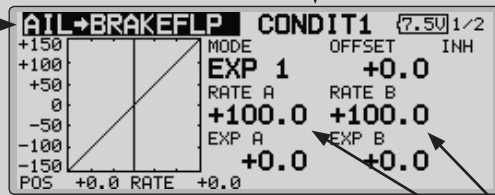

<Edit dial>

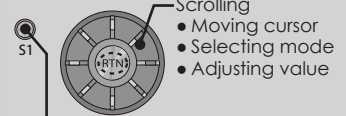

- Push the S1 button to call next page.

- Group/single mode switching

(For more information, refer to the description at the back of this manual.)

- Mixing curve setting  
\*For a description of the curve setting method, see the description at the back of this manual.

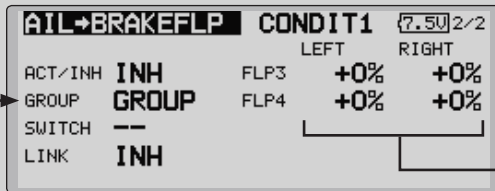

- Left/right overall adjustment at Rate A and Rate B

- Adjustment of each flap servo

### Setting method

- Move the cursor to the ACT/INH item and push the RTN button to switch to the data input mode.

Turn the edit dial to the left and push the RTN button. (ON is displayed.)

- When setting a switch, move the cursor to the [-] item of the switch and push the RTN button to call the selection screen, and then select the switch and set its ON direction. (Always ON at "--" setting)

(For a description of the switch selection method, see the description at the back of this manual.)

- Move the cursor to the left or right button of each flap servo and push the RTN button to switch to the data input mode.

Adjust the mixing rate with the edit dial.

Push the RTN button to end adjustment and return to the cursor move mode.

\*When the mixing direction is reversed by the linkage, adjustments can be made by reversing the mixing rate polarity (+ or -).

- A mixing curve can be set.

(For a description of the curve setting method, see the description at the back of this manual.)

- To set linking, move the cursor to the Link item and push the RTN button to switch to the data input mode.

Set it to ON and push the RTN button.

## AIL to RUD

[Corresponding model type]:  
Airplane/glider, general

Use this mix when you want to mix the rudders with aileron operation.

- A mixing curve can be set.
- Mixing during flight can be turned ON/OFF by setting a switch. (Always ON at [-] setting)
- The mixing rate can be fine-tuned by setting a VR.

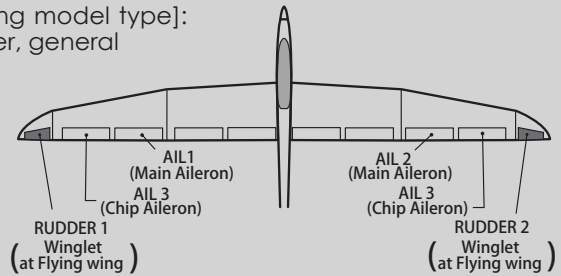

- Select [AIL to RUD] at the model menu and call the setup screen shown below by pushing the RTN button.

(Currently selected condition name)

- Select the function name and return to the preceding screen by pushing the RTN button or pushing the Home/Exit button.

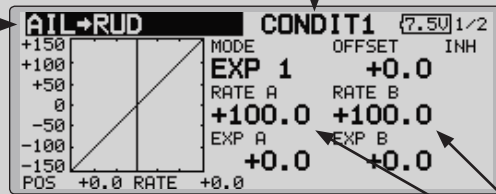

- Push the S1 button to call next page.

- Mixing curve setting  
\*For a description of the curve setting method, see the description at the back of this manual.

- Group/single mode switching

(For more information, refer to the description at the back of this manual.)

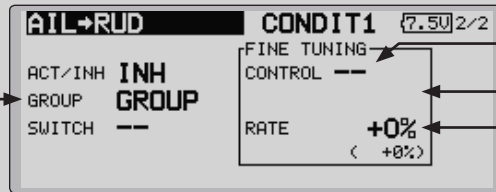

\*The display screen is an example. The actual screen depends on the model type.

- Fine tuning VR setting
- Operation mode
- Adjustment rate

- Left/right overall adjustment at Rate A and Rate B

### Setting method

- Move the cursor to the ACT/INH item and push the RTN button to switch to the data input mode.  
Turn the edit dial to the left and push the RTN button. (ON is displayed.)
- When setting a switch, move the cursor to the [-] item of the switch and push the RTN button to call the selection screen, and then select the switch and set its ON direction. (Always ON at "--" setting)  
(For a description of the switch selection method, see the description at the back of this manual.)
- When setting a VR, move the cursor to the Fine Tuning "--" item and push the RTN button to call the selection screen, and then select the VR. The adjustment rate can be set. The VR operation mode can also be selected.

- A mixing curve can be set.

(For a description of the curve setting method, see the description at the back of this manual.)

#### [Fine tuning VR operation mode]

- [LIN.] Mixing rate 0% at center of VR. When the VR is turned clockwise and counterclockwise, the mixing rate increases and decreases, respectively.
- [ATL+] Mixing rate 0% at left end of VR. When the VR is turned, the mixing rate increases.
- [ATL-] Mixing rate 0% at right end of VR. When the VR is turned, the mixing rate increases.
- [SYM.] When the VR is turned to the left or right of the neutral position, the mixing rate increases.

## AIRBRAKE to ELE

[Corresponding model type]:  
Airplane/glider, general

This mix is used when you want to mix the elevators with airbrake (spoiler) operation. It raises the elevators to correct for dropping of the nose during airbrake operation.

\*This function does not operate when airbrake is not assigned at the Function menu in the Linkage Menu.

- The Rate 1 side/Rate 2 side mixing rate with the elevator servos can be adjusted.
- A mixing curve can be set.
- Mixing during flight can be turned ON/OFF by setting a switch. (Always ON at [-] setting)
- The mixing rate can be fine-tuned by setting a VR.

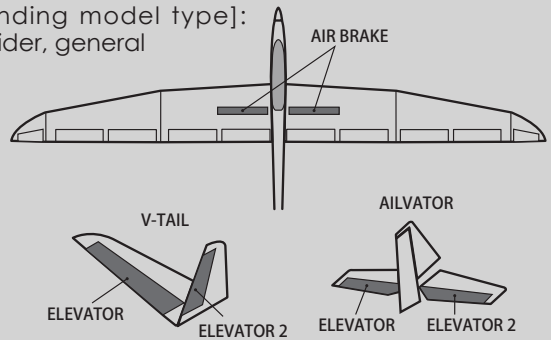

\*The display screen is an example. The actual screen depends on the model type.

- Select [AIRBRAKE to ELE] at the model menu and call the setup screen shown below by pushing the RTN button.

- Select the function name and return to the preceding screen by pushing the RTN button or pushing the Home/Exit button.

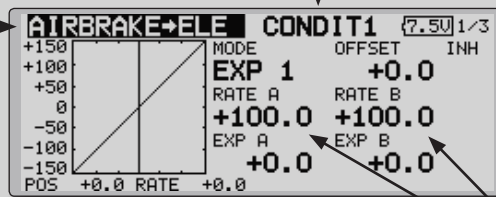

(Currently selected condition name)

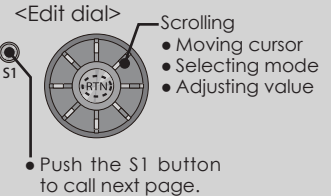

- Mixing curve setting

\*For a description of the curve setting method, see the description at the back of this manual.

- Group/single mode switching

(For more information, refer to the description at the back of this manual.)

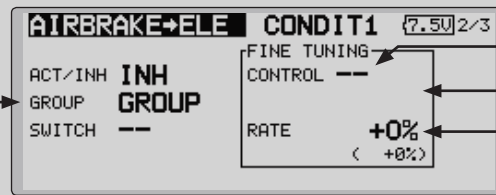

- Overall adjustment by Rate A and Rate B.

- Fine tuning VR setting

- Operation mode

- Adjustment rate

- Adjustment of each elevator servo

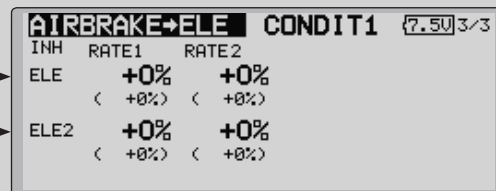

### Setting method

- Move the cursor to the ACT/INH item and push the RTN button to switch to the data input mode.  
Turn the edit dial to the left and push the RTN button. (ON is displayed.)
- When setting a switch, move the cursor to the [--] item of the switch and push the RTN button to call the selection screen, and then select the switch and set its ON direction. (Always ON at "--" setting)  
(For a description of the switch selection method, see the description at the back of this manual.)
- When setting a VR, move the cursor to the Fine tuning "--" item and push the RTN button to call the selection screen, and then select the VR. The adjustment rate can be set. The VR operation mode can also be set.  
(For a description of the fine tuning VR setting method, see the description at the back of this manual.)
- A mixing curve can be set.  
(For a description of the curve setting method, see the description at the back of this manual.)

[Fine tuning VR operation mode]

[LIN.] Mixing rate 0% at center of VR.  
When the VR is turned clockwise and counterclockwise, the mixing rate increases and decreases, respectively.

[ATL+] Mixing rate 0% at left end of VR.  
When the VR is turned, the mixing rate increases.

[ATL-] Mixing rate 0% at right end of VR.  
When the VR is turned, the mixing rate increases.

[SYM.] When the VR is turned to the left or right of the neutral position, the mixing rate increases.

## RUD to AIL

[Corresponding model type]:  
Airplane/glider, general

This function is used when you want to mix the ailerons with rudder operation. It is used when rudder is applied during roll maneuvers, knife edge, etc. of stunt planes. It can be used to bank scale models, large models, etc. like a full size plane.

- A mixing curve can be set.
- Mixing during flight can be turned ON/OFF by setting a switch. (Always ON at [-] setting)
- Linking can be set: Link this mix to other mixes.
- The mixing rate can be fine-tune by setting a VR.

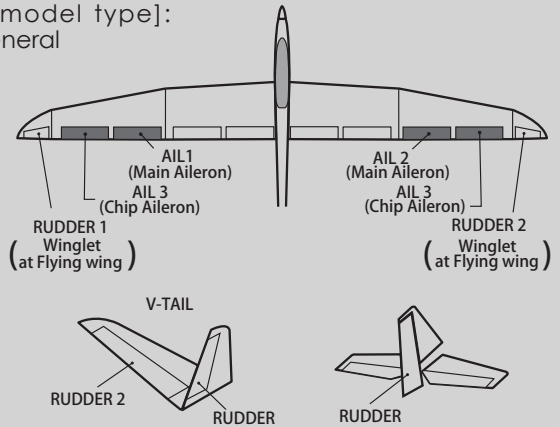

(Currently selected condition name)

- Select the function name and return to the preceding screen by pushing the RTN button or pushing the Home/Exit button.

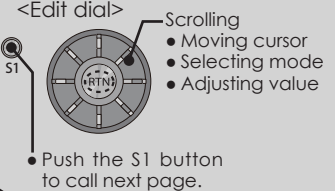
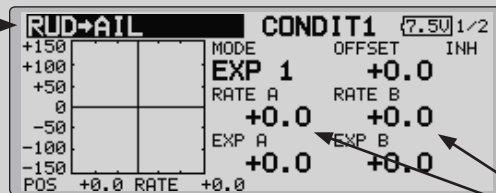

- Group/single mode switching  
(For more information, refer to the description at the back of this manual.)

- Mixing curve setting  
\*For a description of the curve setting method, see the description at the back of this manual.

- Left/right overall adjustment at Rate A and Rate B

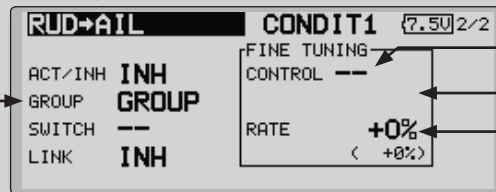

- Fine tuning VR setting
- Operation mode
- Adjustment rate

\*The display screen is an example. The actual screen depends on the model type.

### Setting method

- Move the cursor to the ACT/INH item and push the RTN button to switch to the data input mode.  
Turn the edit dial to the left and push the RTN button. (ON is displayed.)
- When setting a switch, move the cursor to the [-] item of the switch and push the RTN button to call the selection screen, and then select the switch and set its ON direction. (Always ON at "--" setting)  
(For a description of the switch selection method, see the description at the back of this manual.)
- When setting a VR, move the cursor to the Fine tuning "--" item and push the RTN button to call the selection screen and then select the VR. The adjustment rate can be set.  
The VR operation mode can also be set.  
(For a description of the fine tuning VR setting method, see the description at the back of this manual.)

- A mixing curve can be set.  
(For a description of the curve setting method, see the description at the back of this manual.)
- When linking: move the cursor to the [LINK] item and push the RTN button to switch to the data input mode. Turn the edit dial to the left and push the RTN button. (ON is displayed.)

[Fine tuning VR operation mode]

[LIN.] Mixing rate 0% at center of VR. When the VR is turned clockwise and counterclockwise, the mixing rate increases and decreases, respectively.

[ATL+] Mixing rate 0% at left end of VR. When the VR is turned, the mixing rate increases.

[ATL-] Mixing rate 0% at right end of VR. When the VR is turned, the mixing rate increases.

[SYM.] When the VR is turned to the left or right of the neutral position, the mixing rate increases.

## CAMBER MIX

[Corresponding model type]: Airplane/glider, 2 ailerons or more

This function adjusts the AFR (D/R) rate of camber operation which operates the wing camber (ailerons, camber flaps, brake flaps) in the negative and positive directions. The aileron, flap, and elevator rates can also be adjusted independently by curve, and attitude changes caused by camber operation can be corrected.

\*Initial setting assigns camber operation to side lever LS.

- The up/down side rates of the aileron, flap, and elevator servos can be adjusted by curve. When the mixing direction is reversed by the linkage, adjustments can be made by changing the mixing rate polarity (+ or -).

- Mixing during flight can be turned ON/OFF by setting a switch. (Always ON at [-] setting)
- A delay can be set for each condition. A cut switch which can turn OFF the delay function can be set.
- The speed of the aileron, flap, and elevator servos can be set. (IN side/OUT side)

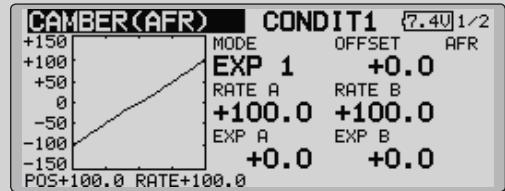

- Select [CAMBER MIX] at the model menu and call the setup screen shown below by pushing the RTN button.

- Camber AFR (D/R) setup screen call (For a description of the setting method, refer to the AFR function.)

(Currently selected condition name)

- Select the function name and return to the preceding screen by pushing the RTN button or pushing the Home/Exit button.

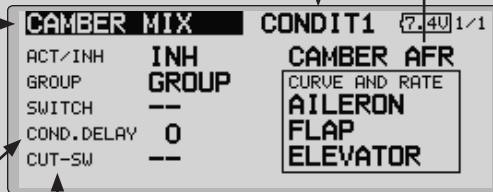

- Scrolling
  - Moving cursor
  - Selecting mode
  - Adjusting value
- Push the S1 button to call next page.

- Condition delay setting

- Condition delay cut switch

- Overall adjustment by Rate A and Rate B

(Curve/rate setting screen)

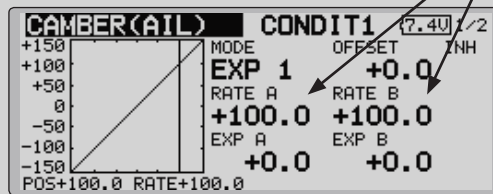

- Mixing curve setting

\*For a description of the curve setting method, see the description at the back of this manual.

- Aileron rate adjustment

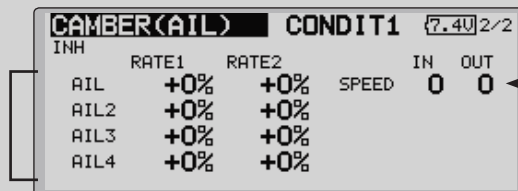

- Servo speed setting

(For a description of the setting method, see the description at the back of this manual.)

\*The display screen is an example. The actual screen depends on the model type.



## Setting method

- Move the cursor to the ACT/INH item and push the RTN button to switch to the data input mode.

Turn the edit dial to the left and push the RTN button. (ON is displayed.)

- When setting a switch, move the cursor to the [--] item of the switch and push the RTN button to call the selection screen, and then select the switch and set its ON direction. (Always ON at "--" setting)

(For a description of the switch selection method, see the description at the back of this manual.)

- When setting a condition delay, move the cursor to the [COND.DELAY] item and push the RTN button to switch to the data input mode.

Set the delay with the edit dial.

Push the RTN button to end adjustment and return to the cursor move mode.

When setting a cut switch, move the cursor to [CUT-SW] item and push the RTN button to call the selection screen, and then select the

switch and set its ON direction. (Always ON at [--] setting)

(For a description of the condition delay function, see the description at the back of this manual.)

- Camber AFR(D/R) screen call

Move the cursor to the Camber AFR item and push the RTN button to call the setup screen. (For a description of the setup method, see the description at the back of this manual.)

(Curve/rate setup screen)

- The curve and rate are adjusted by calling the aileron, flap, and elevator curve/rate screens.

The rate and curve of each servo can be set by calling each screen. (For a description of the curve setting method, see the description at the back of this manual.)

The servo speed can also be adjusted.

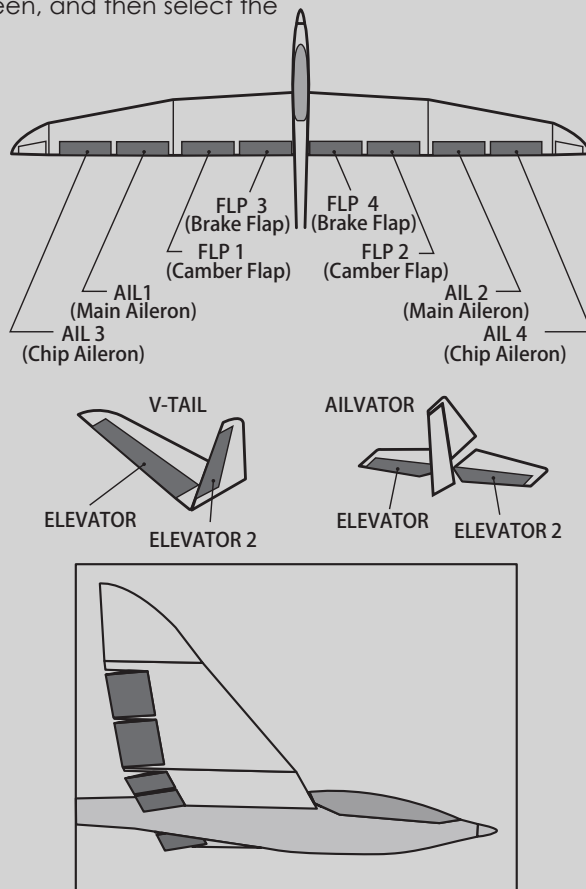

## ELE to CAMBER

[Corresponding model type]: Airplane/glider, 2 ailerons or more

This function is used when you want to mix the camber flaps with elevator operation. When used, the flaps are lowered by up elevator, and lift can be increased.

- Select [ELE to CAMBER] at the model menu and call the setup screen shown below by pushing the RTN button.

**Note: Tailless wing elevator can be operated when this mix is activated.**

- A mixing curve can be set.
- Mixing during flight can be turned ON/OFF by setting a switch. (Always ON at [-] setting)
- The mixing rate can be fine-tuned by setting a VR.

(Currently selected condition name)

• Select the function name and return to the preceding screen by pushing the RTN button or pushing the Home/Exit button.

• Mixing curve setting  
\*For a description of the curve setting method, see the description at the back of this manual.

• Overall adjustment by Rate A and Rate B.

• Ailerons and flaps rate adjustment

1. Select the rate box and push the RTN button to switch to the data input mode.
2. Adjust the rates by scrolling the edit dial.
3. Push the RTN button to end adjustment and return to the cursor move mode.

\*The display screen is an example. The actual screen depends on the model type.

• Group/single mode switching  
(For more information, refer to the description at the back of this manual.)

• Fine tuning VR setting

• Operation mode

• Adjustment rate

<Edit dial>

- Scrolling
- Moving cursor
- Selecting mode
- Adjusting value

• Push the S1 button to call next page.

### Setting method

- Move the cursor to the ACT/INH item and push the RTN button to switch to the data input mode.

Turn the edit dial to the left and push the RTN button. (ON is displayed.)

- When setting a switch, move the cursor to the [-] item of the switch and push the RTN button to call the selection screen, and then select the switch and set its ON direction. (Always ON at "--" setting)

(For a description of the switch selection method, see the description at the back of this manual.)

- When setting a VR, move the cursor to the Fine tuning "--" item and push the RTN button to call the selection screen, and then select the VR. The adjustment rate can be set.

The VR operation mode can also be selected.

- A mixing curve can also be set.

(For a description of the curve setting method, see the description at the back of this manual.)

## CAMB.FLP to ELE

[Corresponding model type]: Airplane/  
glider, 2 ailerons + 1 flap or more

This mixing is used to correct changes (elevator direction) generated when the camber flaps (speed flaps) are used.

- The elevator servos up side/down side rate can be adjusted. When the mixing direction is reversed by the linkage, adjustments can be made by changing the mixing rate polarity (+ or -).
- A mixing curve can be set.
- Mixing during flight can be turned ON/OFF by setting a switch. (Always ON at [-] setting)
- The mixing rate can be fine-tuned by setting a VR.

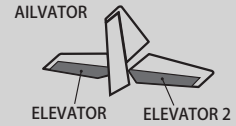
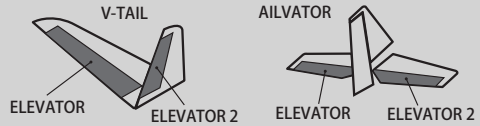
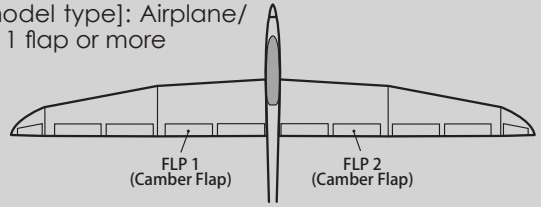

- Select [CAMB.FLP to ELE] at the model menu and call the setup screen shown below by pushing the RTN button.

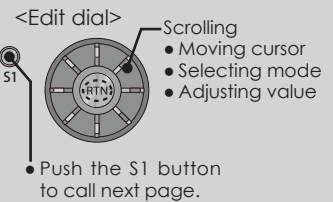
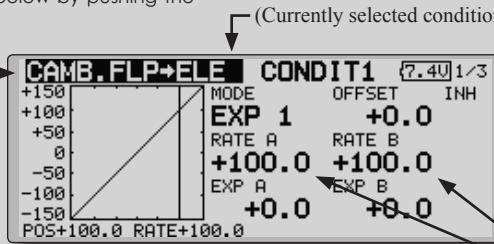

- Select the function name and return to the preceding screen by pushing the RTN button or pushing the Home/Exit button.

- Group/single mode switching  
(For more information, refer to the description at the back of this manual.)

- Mixing curve setting  
\*For a description of the curve setting method, see the description at the back of this manual.

- Overall adjustment by Rate A and Rate B.

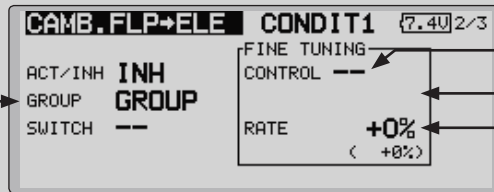

- Elevator rate adjustment

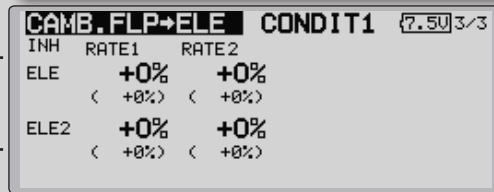

\*The display screen is an example. The actual screen depends on the model type.

### Setting method

- Move the cursor to the ACT/INH item and push the RTN button to switch to the data input mode.  
Turn the edit dial to the left and push the RTN button. (ON is displayed.)
- When setting a switch, move the cursor to the [-] item of the switch and push the RTN button to call the selection screen, and then select the switch and set its ON direction. (Always ON at "-" setting)  
(For a description of the switch selection method, see the description at the back of this manual.)
- Move the cursor to the elevator servos left and right item and push the RTN button to

switch to the data input mode. Adjust the mixing rate with the edit dial.

Push the RTN button to end adjustment and return to the cursor move mode.

\*When the mixing direction is reversed by the linkage, adjustments can be made by changing the mixing rate polarity (+ or -).

- When setting a VR, move the cursor to the Fine tuning "-" item and push the RTN button to call the selection screen, and then select the VR. The VR operation mode can be selected.
- A mixing curve can be set.  
(For a description of the curve setting method, see the description at the back of this manual.)

## BUTTERFLY

[Corresponding model type]: Glider, 2 ailerons or more

This function allows powerful brake operation by simultaneously raising the left and right ailerons and lowering the flaps (camber flap, brake flap).

This setting will allow the ailerons to be raised while the flaps are simultaneously lowered. Butterfly (crow) produces an extremely efficient landing configuration by accomplishing the following:

1. Slow the aircraft's velocity.
2. Provide washout at the wing tips to reduce the tendency to tip stall.
3. Create more lift toward the center of the wing allowing it to fly at a slower speed

- Select [BUTTERFLY] at the model menu and call the setup screen shown below by pushing the RTN button.

- Select the function name and return to the preceding screen by pushing the RTN button or pushing the Home/Exit button.

- Select the Mixing Rate AIL and FLP box and push the RTN button to switch to the data input mode. Adjust the mixing rates. Push the RTN button to end adjustment and return to the cursor move mode.

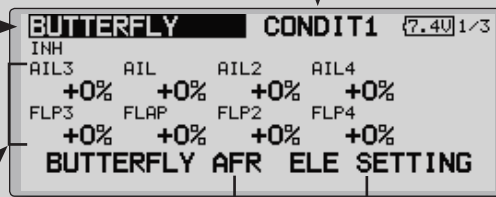

- Mixing during flight can be turned ON/OFF by setting a switch. (Always ON at [-] setting)
- The butterfly operation reference point can be offset. When the RTN button is pushed with the offset item selected when operated to the position to be changed, the reference point is offset. If the reference point is offset too much, unexpected operation may be performed.
- The ailerons and flaps operation speed can be adjusted. (IN side/OUT side)
- A delay can be set for each condition. A cut switch which can turn OFF the delay function can also be set.
- The differential rate can be adjusted.

\*When servo binding occurs when setting the ailerons and flaps in butterfly mixing, use the AFR function to adjust the rudder angle.

\*The display screen is an example. The actual screen depends on the model type.

(Currently selected condition name)

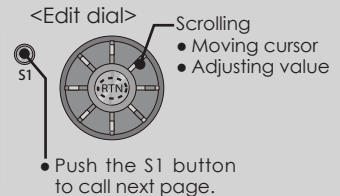

- To elevator correction setup screen

- Calls the Butterfly AFR (D/R) setup screen

(For a description of the setting method, see the description at the back of this manual.)

- When using this function, move the cursor to the [ACT/INH] item and push the RTN button to switch to the data input mode. Turn the edit dial to the left and push the RTN button. (ON is displayed.)

- Group/single mode switching

(For more information, see the description at the back of this manual.)

- When setting a switch, select the SWITCH [-] box and push the RTN button to switch to the data input mode. Press the EDIT button to call the selection screen, and then select the switch and set its ON direction.

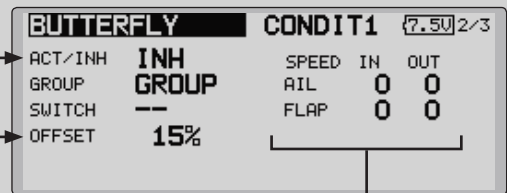

- Aileron and flap servos speed setting

(For a description of the setting method, see the description at the back of this manual.)

- When offsetting the butterfly operation reference point, operate to the point you want to change and then press the EDIT button for 1 second. "INITIALIZE ELEVATOR CURVE?" is displayed. Please choose whether to initialize by YES, or not to initialize by NO.

- Differential rate adjustment

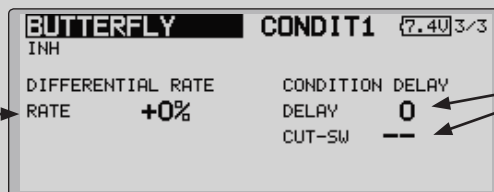

- Condition delay setting and cut switch setting

(For a description of the setting method, see the description at the back of this manual.)

(Elevator correction rate setup screen)

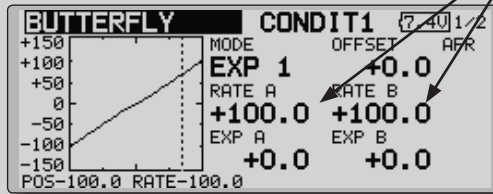

• Overall adjustment by Rate A and Rate B

- Mixing curve setting  
\*For a description of the curve setting method, see the description at the back of this manual.

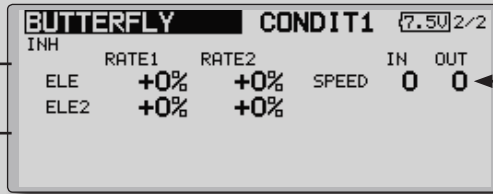

• Elevator rate adjustment

• Servo speed setting  
(For a description of the setting method, see the description at the back of this manual.)

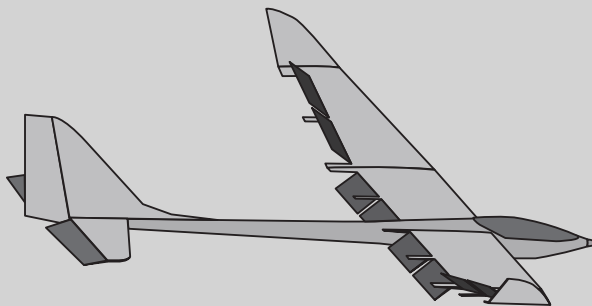
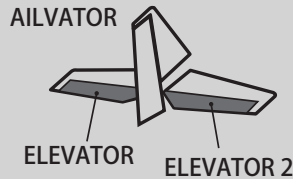
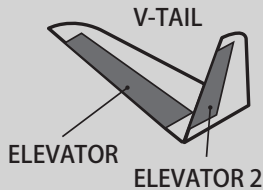
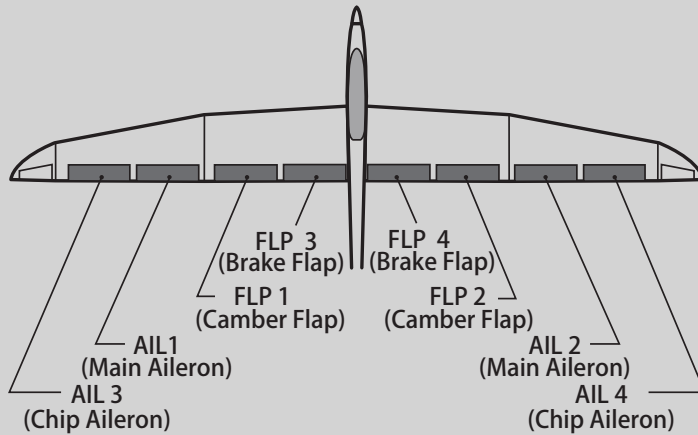

## TRIM MIX 1/2

[Corresponding model type]: Glider, 2 ailerons or more

These functions call the ailerons, elevators, and flaps (camber flaps, brake flaps) trim offset rates preset according to the flight state.

The amount of ailerons, elevator, and flaps (camber flap, brake flap) trim offset can be set to a switch.

As an example **Trim Mix 1** can be set up for launching, with speed flaps and ailerons dropped, and a slight amount of up elevator. **Trim mix 2** can be used for high speed flying, with both ailerons and speed flaps reflexed slightly, and a bit of down elevator.

The trim functions can be activated during flight by setting a switch. To prevent sudden trim changes when switching flight conditions, a delay can be set to provide a smooth transition between the two. Trim Mix 2 will have priority over Trim Mix 1.

- Select [TRIM MIX1 or 2] at the model menu and call the setup screen shown below by pushing the RTN button.

- Select the function name and return to the preceding screen by pushing the RTN button or pushing the Home/Exit button.

(Currently selected condition name)

**TRIM MIX 1**    **CONDIT1**    (7.40) 1/5

INH    AIL3    AIL    AIL2    AIL4

OFFSET    +0%    +0%    +0%    +0%

TUNING    +0%    +0%    +0%    +0%

          < +0%>    < +0%>    < +0%>    < +0%>

**TRIM MIX 1**    **CONDIT1**    (7.50) 2/5

INH    FLP3    FLAP    FLP2    FLP4

OFFSET    +0%    +0%    +0%    +0%

TUNING    +0%    +0%    +0%    +0%

          < +0%>    < +0%>    < +0%>    < +0%>

**TRIM MIX 1**    **CONDIT1**    (7.50) 3/5

INH          ELE    ELE2

OFFSET          +0%    +0%

TUNING          +0%    +0%

          < +0%>    < +0%>

### Example

1. Move to the ACT/INH item and push the RTN button to switch to the data input mode. Set the trim mix function to [ON].
    - \*When separating the settings for each condition, move to the [GROUP] item and set it to [Single].
  2. Select the ON/OFF switch.
  3. Select the [Manual] or [Auto] mode.
    - In the [Auto] mode, also select an auto SW. This switch can be linked to a stick, etc.
- <Speed>  
 In: The operation speed at switch ON can be set.  
 Out: The return speed at switch OFF can be set.
- <Fine Tuning>  
 The offset rate can be varied in the Fine Tuning numeric range set at screen [5/5] by VR, etc. selection.
- <Condition Delay>  
 When flight conditions are set, the operation speed can be set for each condition. Condition delay operation can be interrupted and each rudder quickly returned to its original position by selecting a cut switch.

\*The display screen is an example. The actual screen depends on the model type.

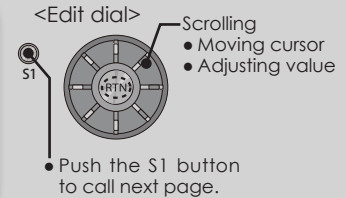

- When a fine tuning VR is set on the next page, the ailerons flaps and elevators trim rates can be adjusted.  
 Move the cursor to the corresponding setting item and push the RTN button to switch to the data input mode. adjust the rate with the edit dial.  
 Push the RTN button to end adjustment and return to the cursor move mode.

- When using this function, move the cursor to the [ACT/INH] item and push the RTN button to switch to the data input mode. Turn the edit dial to the left and push the RTN button. (ON is displayed.)
- Group/single mode switching  
(For more information, see the description at the back of this manual.)

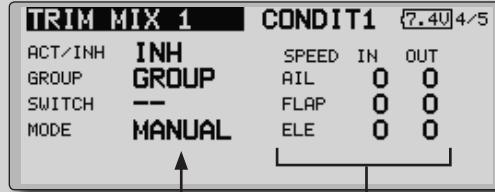

- Manual/Auto mode selection  
Manual: Switches the function ON/OFF by switch  
Auto: Trim mix function call can be linked to a stick, etc. A stick switch, etc. separate from the function ON/OFF switch is set.

- Ailerons, flaps, an elevators servo speed setting  
(For a description of the setting method, see the description at the back of this manual.)

- When using a fine tuning VR, move the cursor to this item and push the RTN button to call the selection screen.  
Select the VR and push the RTN button.

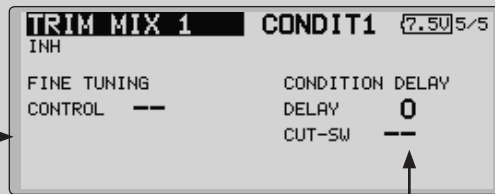

- Condition delay setting (for a description of the setting method, see the description at the back of this manual) and cut switch setting.

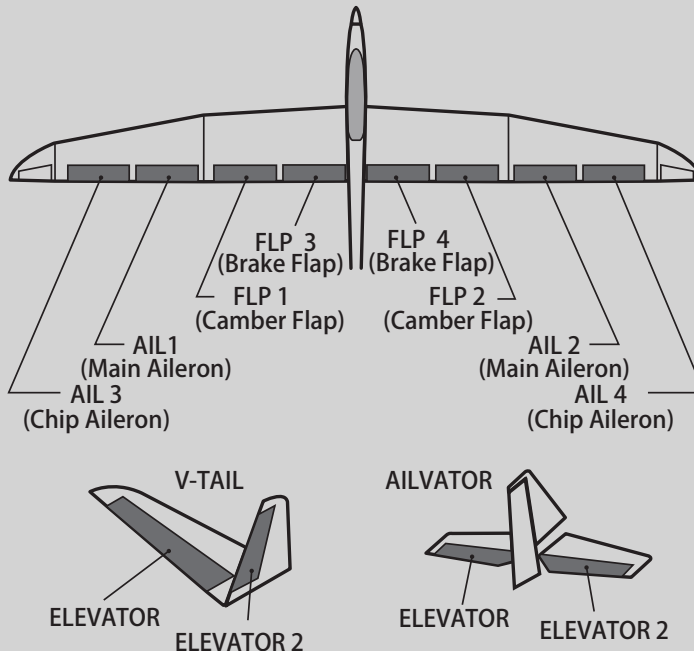

## AIRBRAKE

[Corresponding model type]: Airplane, general

This function is used when an air brake is necessary when landing or diving, etc.

The preset elevators and flaps (camber flap, brake flap) offset amount can be activated by a switch.

The offset amount of the aileron, elevator, and flap servos can be adjusted as needed. Also the speed of the aileron, elevator, and flap servos can be adjusted. (IN side/OUT side) A delay can be set for each condition, and a Cut switch which will turn OFF the delay can be chosen. Trim amounts can be fine-tuned by setting a VR You can also set the Auto Mode, which will link Airbrake to a stick, switch, or dial. A separate stick switch or dial can also be set as the ON/OFF switch.

### Setting example for F3A and other flaperon specifications

(When 2 ailerons model type selected)

Offset rate:

AIL: [-35~-45%], AIL2: [-35~-45%], ELE: [+5~7%]

Note: The input numerics are examples. Adjust the travel to match the aircraft.

Mode setting:

ACT: [ON]

Group: [Single]

Switch: [SW-C]

Mode: [Manual]

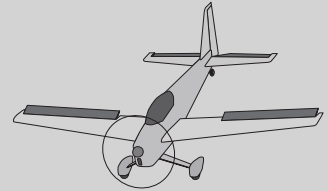

\*The display screen is an example. The actual screen depends on the model type.

- Select [AIRBRAKE] at the model menu and call the setup screen shown below by pushing the RTN button.

- Select the function name and return to the preceding screen by pushing the RTN button or pushing the Home/Exit button.

(Currently selected condition name)

<Edit dial>

Scrolling

- Moving cursor
- Adjusting value

S1

- Push the S1 button to call next page.

- The ailerons, flaps, and elevators offset rate can be adjusted.

Move the cursor to the corresponding setting item and push the RTN button to switch to the data input mode. Adjust the rate with the edit dial.

Push the RTN button to end adjustment and return to the cursor move mode.

- When a fine tuning VR is set on the next page, the ailerons', flaps', and elevators' trim rates can be adjusted.

Move the cursor to the corresponding setting item and push the RTN button to switch to the data input mode. Adjust the rate with the edit dial.

Push the RTN button to end adjustment and return to the cursor move mode.



# Reference

FMT-03 is equipped with a stick of multi-copter exclusive use. Therefore it's unsuitable for use of an airplane, a glider and a helicopter.

- When using this function, move the cursor to the [ACT/INH] item and turn the edit dial to the left and push the RTN button. (ON is displayed.)
- Group/single mode switching  
(For more information, see the description at the back of this manual.)



- Manual/Auto mode selection  
Manual: Switches the function ON/OFF by switch  
Auto: Trim mix function call can be linked to a stick, etc. A stick switch, etc. separate from the function ON/OFF switch is set.
- Ailerons, flaps, and elevators servo speed setting  
(For a description of the setting method, see the description at the back of this manual.)

- When using a fine tuning VR, move the cursor to this setting item and press the EDIT button to call the selection screen.  
Select the VR and push the RTN button.

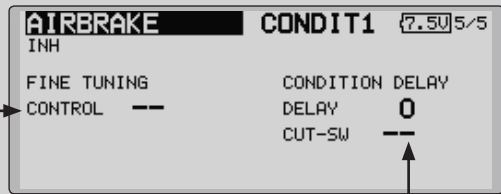

- Condition delay setting (for a description of the setting method, see the description at the back of this manual) and cut switch setting.

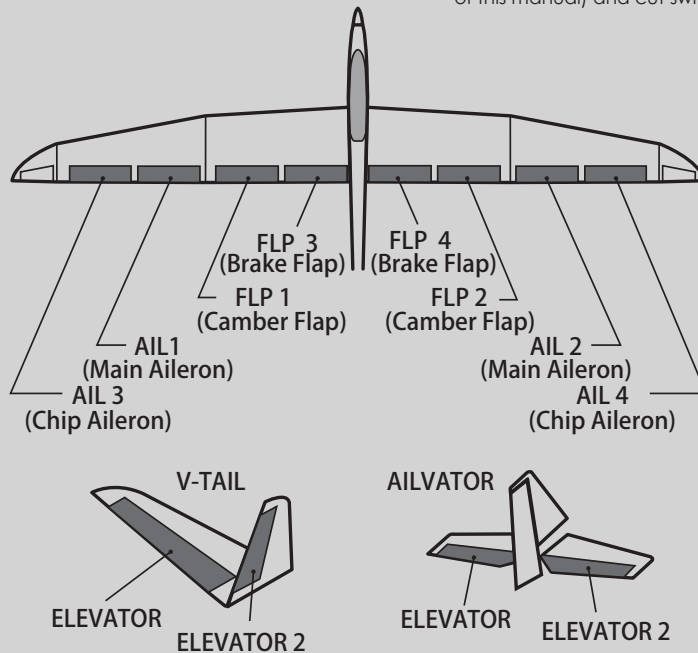

## GYRO

[Corresponding model type]: Airplane/glider, general

This function is used when a GYA Series gyro is used to stabilize the aircraft's attitude. The sensitivity and operation mode (Normal mode/GY mode) can be switched with a switch.

- Three rates (Rate 1/Rate 2/Rate 3) can be switched.
- Up to 3 axes (Gyro/Gyro 2/Gyro 3) can be simultaneously controlled.

- Select [GYRO] at the model menu and call the setup screen shown below by pushing the RTN button.

\*Initial setting does not assign a sensitivity channel. Use the Function menu of the Linkage Menu to assign the sensitivity channel (Gyro/Gyro2/Gyro3) used to a vacant channel beforehand.

Set [Control] and [Trim] other than Function to [--].

- Select the function name and return to the preceding screen by pushing the RTN button or pushing the Home/Exit button.

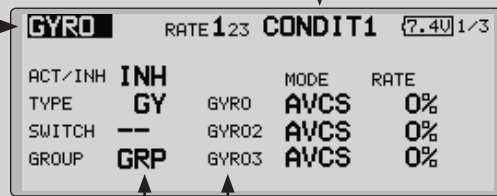

<Edit dial>

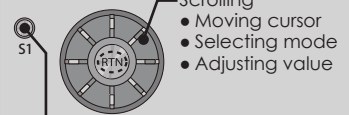

- Push the S1 button to call next page.

- Group/single mode switching  
(For more information, see the description at the back of this manual.)

- The operation mode (AVCS/NOR) and sensitivity of the 3 axis controlled by Gyro/Gyro2/Gyro3 can be set.

- Three rates (Rate 1/Rate 2/Rate 3) can be used.  
Move the cursor to the [RATE] item and push the RTN button to switch to the data input mode. Adjust the rate by scrolling the edit dial.
- When using this function, move the cursor to the [ACT] item and push the RTN button to switch to the data input mode. Turn the edit dial to the left and push the RTN button.
- When a Futaba GYA gyro is used, when [GY] type is selected, the sensitivity set value is directly read in both the AVCS and NORM modes.
- When setting a switch, move the cursor to the SWITCH item and press the EDIT button to call the selection screen, and then select the switch and set its ON direction.  
(For a description of the switch selection method, see the description at the end of this manual.)

## (Example) Setting three axis using a GYA440(2) and GYA441

- Wing type: Aileron 2 servos mounted fuselage selected
- Set **5CH → GYRO** (GYA441AIL), **7CH → GYRO2** (GYA441ELE), **8CH → GYRO3** (GYA440RUD), **Control and Trim → NULL** : at the Function menu of the Linkage menu.
- GYRO setting of the Model menu.

Rate	ACT	Type	Switch	GYRO	GYRO 2	GYRO 3
1	OFF/ON	GY	SE	AVCS : 60%	AVCS : 60%	AVCS : 60%
2	INH					
3	ON/OFF	GY	SE	NORM : 60%	NORM : 60%	NORM : 60%

\*Set so that Rate 1 is turned on at the back position of switch E and Rate 3 is turned ON at the front position. Since switch E is turned OFF at the center, Rate 2 remains [INH].

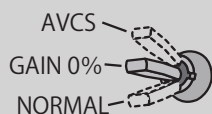

When AVCS is used we recommend that the sensitivity CH be set to the 3-position.

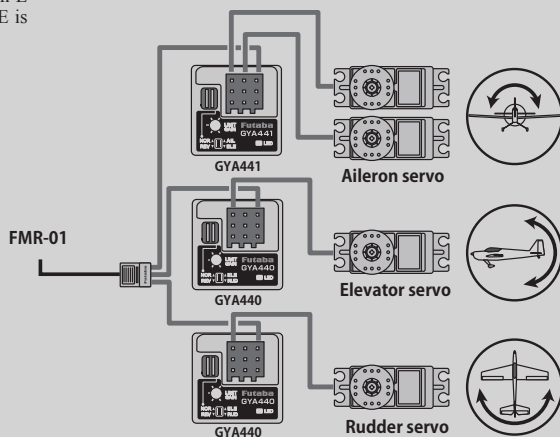

## V-TAIL

[Corresponding model type]: Airplane/glider, V-tail

This function let's you adjust for left and right rudder angle changes at elevator and rudder operation of a V-tail airplane.

V-tail is when 2 servos are used together to control rudder movement as elevators. In addition to each rudder side moving up and down together, each side moves in opposite directions when moving as elevators. On a V-tail, this is also known as a ruddervator, as they can serve the same purpose.

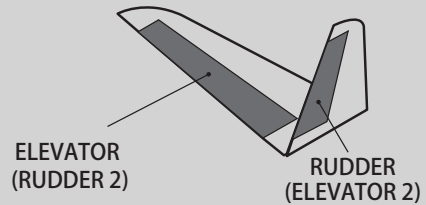

- Select [V-TAIL] at the model menu and call the setup screen shown below by pushing the RTN button.
- Select the function name and return to the preceding screen by pushing the RTN button or pushing the Home/Exit button.
- Group/single mode switching (For more information, see the description at the back of this manual.)

(Currently selected condition name)

V-TAIL		CONDIT1		(7.40)	1/1
GROUP	GROUP				
FUNCTION	ELEVATOR		RUDDER		
	DOWN	UP	LEFT	RIGHT	
ELE <RUD2>	+50%	+50%	+50%	+50%	
RUD <ELE2>	+50%	+50%	+50%	+50%	

(Elevator function)      (Rudder function)

Up and down travel adjustment at CH1 and CH2 elevator operation      Left and right travel adjustment at CH1 and CH2 rudder operation

<Edit dial>

- Scrolling
- Moving cursor
- Selecting mode
- Adjusting value

- Travel adjustment

Move the cursor to the item you want to adjust and push the RTN button to switch to the data input mode.

Adjust the rate by scrolling the edit dial.

Push the RTN button to end adjustment and return to the cursor move mode.

\*If the mixing direction is reversed by the linkage, adjustments can be made by changing the mixing rate polarity (+ or -).

\*If a large value of travel is specified, when the sticks are moved at the same time, the controls may bind or run out of travel. Decrease the travel until no binding occurs.

## AILEVATOR

[Corresponding model type]: Airplane/glider, V-Tail  
(Effective only when 2 servos used at the elevators)

This function improves the operating performance of the roll axis by operating the elevators as ailerons.

Ailevator is where each elevator in a standard (conventional) or v-tail moves independently, like ailerons on a wing. In addition to each elevator side moving up and down together, each side moves in opposite directions when moving as an ailevator. On a V-tail, this is also known as a ruddervator, as they can serve the same purpose. Typically, both ailevator and ailerons are coupled together to maximize roll performance, especially on larger wingspan planes.

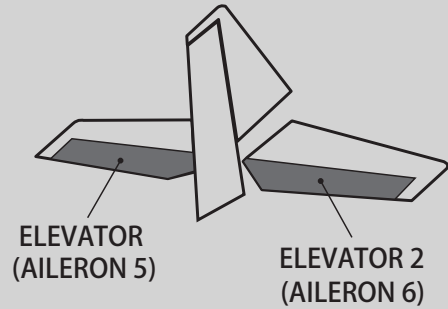

Note: Select ailevator as the Model type at the Model type screen. This changes the output channel. Check the Function menu.

- Select [AILEVATOR] at the model menu and call the setup screen shown below by pushing the RTN button.

- Group/single mode switching  
(For more information, see the description at the back of this manual.)

(Currently selected condition name)

- Select the function name and return to the preceding screen by pushing the RTN button or pushing the Home/Exit button.

AILEVATOR		CONDIT1		7.40	1/1
GROUP	GROUP				
FUNCTION	ELEVATOR	UP	AILERON	RIGHT	
	DOWN		LEFT		
ELE (AIL5)	+100%	+100%	+0%	+0%	
ELE2(AIL6)	+100%	+100%	+0%	+0%	

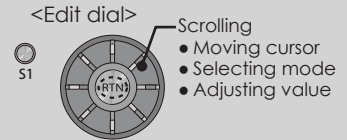

(Elevator function)

- The up and down rate of the left and right elevators when the elevator stick is manipulated can be individually adjusted.

(Aileron function)

- When the elevators are used as ailerons, aileron travel of the left and right elevators can be adjusted.

### • Travel adjustment

Move the cursor to the item you want to adjust and push the RTN button to switch to the data input mode.

Adjust the rate by scrolling the edit dial.

Push the RTN button to end adjustment and return to the cursor move mode.

\*If the mixing direction is reversed by the linkage, adjustments can be made by changing the mixing rate polarity (+ or -).

\*If a large value of travel is specified, when the sticks are moved at the same time, the controls may bind or run out of travel. Decrease the travel until no binding occurs.

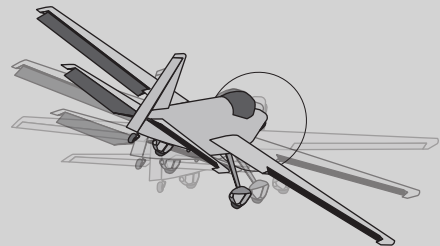

## WINGLET

[Corresponding model type]: Airplane/glider, winglet

This function adjusts the left and right rudder angles of airplanes with winglets.

Winglets are used to improve the efficiency of aircraft lowering the lift-induced drag caused by wingtip vortices. The winglet is a vertical or angled extension at the tips of each wing.

Winglets work by increasing the effective aspect ratio wing without adding greatly to the structural stress and hence necessary weight of its structure - an extension of wing span would also permit lowering of induced drag, though it would cause parasitic drag and would require boosting the strength of the wing and hence its weight - there would come a point at which no overall useful saving would be made. A winglet helps to solve this by effectively increasing the aspect ratio without adding to the span of the wing.

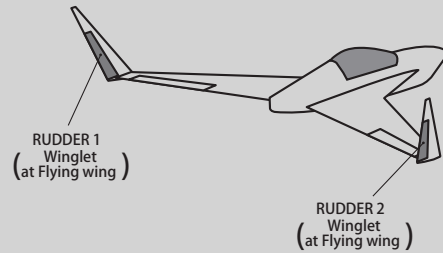

- Select [WINGLET] at the model menu and call the setup screen shown below by pushing the RTN button.
- Group/single mode switching  
(For more information, see the description at the back of this manual.)

(Currently selected condition name)

<b>WINGLET</b>		<b>CONDIT1</b>		7.40	1/1
GROUP	<b>GROUP</b>				
FUNCTION	RUDDER	LEFT	RIGHT		
RUDDER	+100%	+100%			
RUDDER2	+100%	+100%			

(Rudder 1/2)

• Select the function name and return to the preceding screen by pushing the RTN button or pushing the Home/Exit button.

<Edit dial>

- Scrolling
- Moving cursor
- Selecting mode
- Adjusting value

• The travel at rudder stick left and right operation can be individually set.

- Travel adjustment  
Move the cursor to the item you want to adjust and push the RTN button to switch to the data input mode.  
Adjust the rate by scrolling the edit dial.  
Push the RTN button to end adjustment and return to the cursor move mode.  
\*If the mixing direction is reversed by the linkage, adjustments can be made by changing the mixing rate polarity (+ or -).

## MOTOR

[Corresponding model type]: EP glider, general

This function lets you set the operation speed when the motor of a F5B or other EP glider is started by switch. The operation speed can be set in 2 ranges of slow speed flight and high speed flight (Speed 1/Speed 2). This function can also be operated as a safety function by setting 2 switches.

- The in side and out side operating speeds can be adjusted independently in 2 ranges (Speed 1/ Speed 2).
- The boundary between the 2 ranges can be set. (From speed 1 to speed 2)
- The set operation speed operation can be activated at initial operation only. (1 time operation) However, operation can be repeated

- Select [MOTOR] at the model menu and call the setup screen shown below by pushing the RTN button.

- Select the function name and return to the preceding screen by pushing the RTN button or pushing the Home/Exit button.

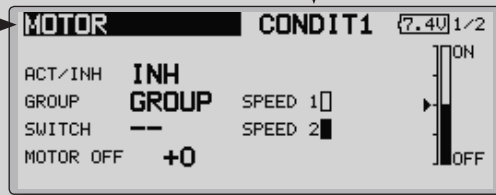

(Currently selected condition name)

<Edit dial>

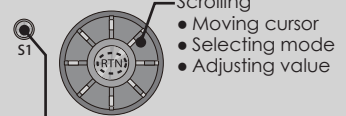

- Push the S1 button to call next page.

- Move the cursor by set switch or VR.

- When using this function, move the cursor to the [ACT/INH] item and push the RTN button to switch to the data input mode. Turn the edit dial to the left and push the RTN button.

- Group/single mode switching  
(For more information, see the description at the back of this manual.)

- Switch  
A switch that turns the function itself ON/OFF can be selected.

- Motor off position  
Press the EDIT button for 1 second when [SW-G] is in the motor OFF position you want to set. The direction of the motor switch is memorized. The screen graph display OFF direction also changes.

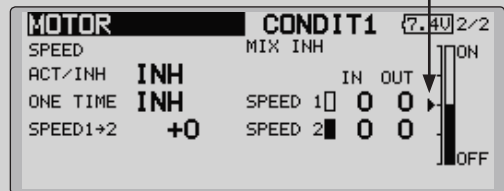

- When using this function, move the cursor to the [ACT/INH] item and push the RTN button to switch to the data input mode. Turn the edit dial to the left and push the RTN button.

- When you want to set the "One time mode", move the cursor to the [ONE TIME] item and turn the edit dial to the left and push the RTN button.

- Speed 1 to 2  
The speed 1 and speed 2 region boundary can be changed,

- Operation speed adjustment  
The speed when speed 1 and speed 2 are ON (In) and OFF (Out) can be adjusted.

### Notes

- First decide the motor OFF direction, and then set the speed. When you want to reset the motor OFF direction, also reset the speed.
- We recommend that motor OFF be set in combination with F/S.
- Set the basic operation direction with the reverse function to match the ESC used.
- Always set the motor OFF position.

## ACCELERATION [Corresponding model type]: Glider, general

Acceleration setting can be performed at elevator, ELE to Camber and AIL to RUD.(Glider and EP glider only)

- This setting is divided into elevator setting and camber setting. The setting method is the same.
- Camber setting sets the acceleration function for ELE to camber mixing. Setting is not performed when ELE to camber mixing is INH.
- The acceleration function can be set for both the up side and down side.

- Function ON/OFF switch setting is performed for ALL to RUD setting only.
- ALL to RUD setting is acceleration function setting for ALL to RUD mixing. It is not performed when ALL to RUD mixing is INH.

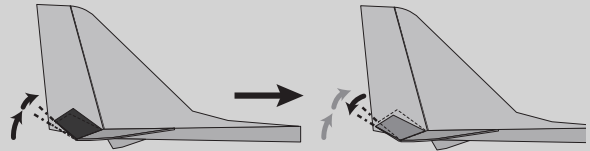

- Select [ACCELERATION] at the model menu and call the setup screen shown below by pushing the RTN button.

- Select the function name and return to the preceding screen by pushing the RTN button or pushing the Home/Exit button.

- 1/3 Elevator setting

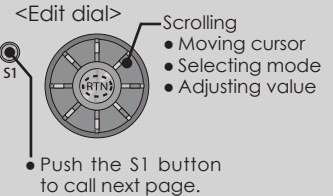
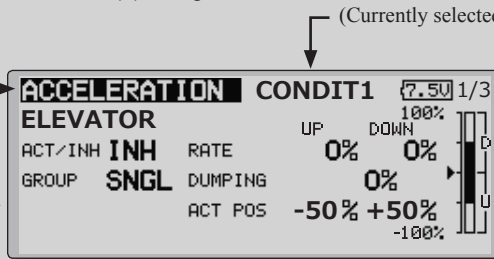

- 2/3 Elevator → Camber setting

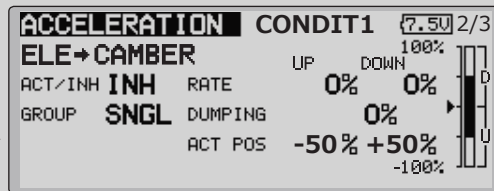

- 3/3 Aileron → Rudder setting

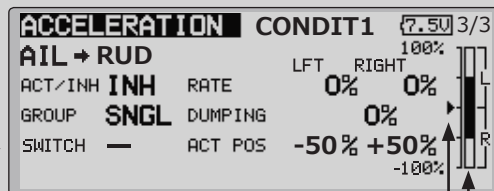

- Act position
- Current position

### Setting method

- Acceleration rate setting (Rate)
- The return time after operation (Dumping) can be set.
- The operation point at acceleration and deceleration can be set. When an operation point is exceeded, acceleration is performed.

Note: When using the acceleration function, since the servo stroke is large, make your settings so there is no binding of your linkage.



## RUD to ELE

[Corresponding model type]: Airplane, general

This function is used when you want to mix elevator operation with rudder operation. It is used to correct undesirable tendencies when rudder is applied in roll maneuvers, knife edge, etc. of stunt planes.

- A mixing curve can be set.
- Mixing during flight can be turned ON/OFF by setting a switch. (Always ON at [-] setting)

- Link can be set: Links this mixing to other mixings.
- The mixing rate can be fine-tuned by setting a VR. (Fine tuning)

- Select [RUD to ELE] at the model menu and call the setup screen shown below by pushing the RTN button.

- Select the function name and return to the preceding screen by pushing the RTN button or pushing the Home/Exit button.

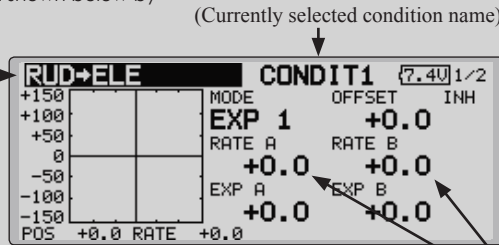

- Push the S1 button to call next page.

- Mixing curve setting

\*For a description of the curve setting method, see the description at the back of this manual.

- Left/right overall adjustment at rate A and rate B

- Group/single mode switching  
(For more information, refer to the description at the back of this manual.)

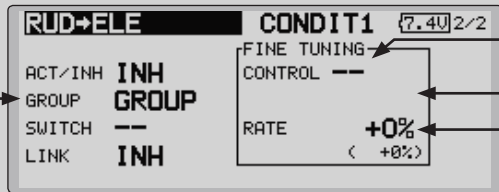

- Fine tuning VR setting

- Operation mode

- Adjustment rate

\*The display screen is an example. The actual screen depends on the model type.

### Setting method

- Move the cursor to the ACT/INH item and push the RTN button to switch to the data input mode. Turn the edit dial to the left and push the RTN button. (ON is displayed.)
- When setting a switch, move the cursor to the [-] item of the switch and push the RTN button to call the selection screen, and then select the switch and set its ON direction. (Always ON at "--" setting)  
(For a description of the switch selection method, see the description at the back of this manual.)
- When setting a VR, move the cursor to the Fine Tuning "--" item and push the RTN button to call the selection screen, and then select the VR. The fine tuning rate can be set. The VR operation mode can also be set.

(For a description of the fine tuning VR setting method, see the description at the back of this manual.)

- When setting Link, move the cursor to the Link item and push the RTN button to switch to the data input mode. Set it to ON.

[Fine tuning VR operation mode]

[LIN.] Mixing rate 0% at center of VR. When the VR is turned clockwise and counterclockwise, the mixing rate increases and decreases, respectively.

[ATL+] Mixing rate 0% at left end of VR. When the VR is turned, the mixing rate increases.

[ATL-] Mixing rate 0% at right end of VR. When the VR is turned, the mixing rate increases.

[SYM.] When the VR is turned to the left or right of the neutral position, the mixing rate increases.

## SNAP ROLL

[Corresponding model type]: Airplane, general

This function selects the switch and rate adjustment of each rudder, (ailerons, elevators, or flaps) when a snap roll is performed.

- Four snap roll directions can be set. (Right/up, right/down, left/up, left/down)
- Operation mode: When [Master] mode is selected, the Snap Roll function is turned ON/OFF by master switch in the state in which the direction switch was switched to the direction in which you want to snap roll. When [Single] mode is selected, snap roll in each direction can be executed by means of independent switches.
- A safety switch can be set. As a safety measure, the switch can be set so that snap roll is not executed when, for instance, the landing gear is lowered, even if the switch is turned on accidentally. The snap roll switch is activated only when the safety switch is ON.
- The operation speed of the aileron, elevator, and flap servos can be adjusted for each snap roll direction. (In side/out side)

### (Example) Setting example for F3A

- Mode: [Master]
- Safety SW: [SW-G] (Safety measure)
- Master SW: [SW-H] (Main switch for executing snap roll)
- Direction switches:  
\*The snap roll up side left and right and down side left and right direction switches are selected here.  
Right/Up: OFF [SW-D]  
Right/Down: OFF [SW-D]  
Left/Up: OFF [SW-A]  
Left/Down: OFF [SW-A]
- Speed adjustment  
The operation speed of each control surface when the snap switch is ON can be changed and snap roll executed by stick while there is switch operation can be performed.

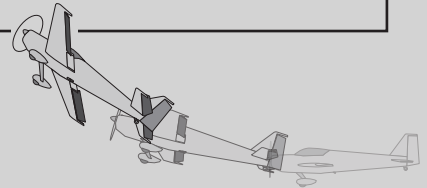

- Select [SNAP ROLL] at the model menu and call the setup screen shown below by pushing the RTN button.

- Select the function name and return to the preceding screen by pushing the RTN button or pushing the Home/Exit button.

(Currently selected condition name)

SNAP ROLL		CONDIT1		[7.4U] 1/4
RATE	AIL	ELE	RUD	
RIGHT/UP	+100%	+100%	+100%	
RIGHT/DOWN	+100%	-100%	-100%	
LEFT/UP	-100%	+100%	-100%	
LEFT/DOWN	-100%	-100%	+100%	

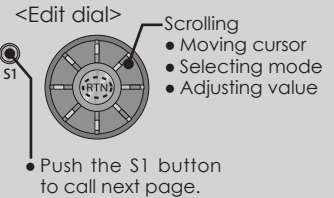

SNAP ROLL		CONDIT1		[7.4U] 2/4
MODE	MASTER			
MASTER-SW	--			
SAFETY-SW	--			
GROUP	GROUP			

- Rate adjustment
  1. Move the cursor to the item you want to adjust and push the RTN button to switch to the data input mode.
  2. Adjust rate by scrolling the edit dial.
  3. Push the RTN button to end adjustment and return to the cursor move mode.

- Group/single mode switching  
(For more information, see the description at the back of this manual.)

SNAP ROLL		CONDIT1		[7.4U] 3/4
	ACT	SWITCH		
RIGHT/UP	OFF	--		
RIGHT/DOWN	OFF	--		
LEFT/UP	OFF	--		
LEFT/DOWN	OFF	--		

- Direction switches

SNAP ROLL		CONDIT1		[7.4U] 4/4		
SPEED	AIL IN	OUT	ELE IN	OUT	RUD IN	OUT
RIGHT/UP	0	0	0	0	0	0
RIGHT/DOWN	0	0	0	0	0	0
LEFT/UP	0	0	0	0	0	0
LEFT/DOWN	0	0	0	0	0	0

- Adjustment of the servo speed of each rudder  
(For a description of the setting method, see the description at the back of this manual.)

## MODEL MENU (HELICOPTER)

This section contains information on the commands that apply to helicopters only. For instructions on airplanes and sailplanes, refer to the sections pertaining to those aircraft.

Use the Model Type function in the Linkage Menu to select the swash type matched to the fuselage beforehand.

Also, add flight conditions at the Condition Select screen if necessary before setting the model

- Select the [MODEL] at the home screen and call the model menu shown below by pushing the RTN button.
- Use the edit dial to select the function you want to set and call the setup screen by pushing the RTN button.

data at each function. (Up to 8 conditions can be used)

The AFR function, dual rate function and other functions common to all model types, are described in a separate section.

• Select the function name and return to the preceding screen by pushing the RTN button or pushing the Home/Exit button.

<b>MODEL MENU</b> NORMAL 7.40 1/2	
SERVO MONITOR	PROG. MIXES
COND. SELECT	PIT CURVE
AFR	THR CURVE
DUAL RATE	ACCELERATION
COND. HOLD IS OFF	

<b>MODEL MENU</b> IDLEUP3 7.50 2/2	
THR HOLD	PIT→RUD
SWASH MIX	GYRO
THROTTLE MIX	GOVERNOR
PIT→NEEDLE	COND. HOLD ←
COND. HOLD IS OFF ←	

\*Condition hold operation is displayed.

### To activate/deactivate Condition Hold:

1. Move the cursor to [COND. HOLD].
2. Set the throttle stick lower than the 1/3 point and push the RTN button to activate/deactivate the condition hold function.

\*Refer to for condition hold function details.

## Model Menu functions (helicopter) list

**PIT CURVE:** Adjusts response in different flight conditions

**THR CURVE:** Throttle curve and hovering trim adjustment

**ACCELERATION:** Allows a brief "overload" in response to sudden throttle and pitch commands

**THR HOLD:** Moves the throttle to idle during autorotation

**SWASH MIX:** Compensates for each control response

**THROTTLE MIX:** Compensates for power loss when cyclic applied

**PIT to NEEDLE:** Adjusts response curve in different flight conditions

**PIT to RUD:** Handles torque changes from pitch angle inputs

**GYRO:** Used to switch gyro sensitivity

**GOVERNOR:** Used to switch RPM of the helicopter's head

## Servo connection by Helicopter type

The FMT-03 transmitter channels are automatically assigned for optimal combination according to the type selected with the Model Type function of the Linkage Menu. The channel assignment (initial setting) for helicopter type is shown below. Connect the receiver and servos to match the type used.

\*The set channels can be checked at the Function screen of the Linkage Menu. The channel assignments can also be changed. For more information, read the description of the Function menu.

### Helicopter

#### ●FASSTest 18CH

CH	H-4/H-4X Swash	All Other
1	Aileron	Aileron
2	Elevator	Elevator
3	Throttle	Throttle
4	Rudder	Rudder
5	Gyro	Gyro
6	Pitch	Pitch
7	Governor	Governor
8	Elevator2	Governor2
9	GYRO2	GYRO2
10	GYRO3	GYRO3
11	Governor2	Needle
12	Needle	AUX5
13	AUX4	
14	AUX3	
15	AUX2	
16	AUX1	
DG1	SW	
DG2		

#### ●FASSTest 12CH

CH	H-4/H-4X Swash	All Other
1	Aileron	Aileron
2	Elevator	Elevator
3	Throttle	Throttle
4	Elevator2	Rudder
5	Pitch	Pitch
6	Gyro	Gyro
7	Governor	Governor
8	Rudder	Governor2
9	GYRO2	GYRO2
10	GYRO3	GYRO3
DG1	SW	
DG2		

## PIT CURVE/PIT TRIM

### PIT Curve

This function adjusts the pitch operation curve for each flight condition for the optimal flight state relative to movement of the throttle stick.

\*Up to 17 points can be set for the point curve types. However, when using the 3 points or 5 points specified to create a curve, a simple curve can be created by reducing

the number of input points to 3 or 5, and then entering the specified value at the corresponding points that you created a curve.

- Select [PIT CURVE] at the model menu and call the setup screen shown below by pushing the RTN button.

- Point curve type is 9 points (initial), but for simple use, 4~5 points are sufficient.

- Select the function name and return to the preceding screen by pushing the RTN button or pushing the Home/Exit button.

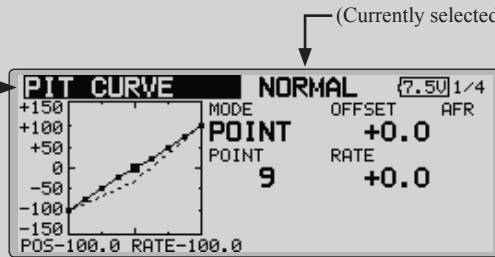

(Currently selected condition name)

<Edit dial>

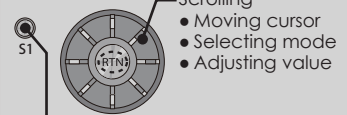

- Push the S1 button to call next page.

- Mixing curve setting

\*For a description of the curve setting method, see the description at the back of this manual.

- Pitch trim copy

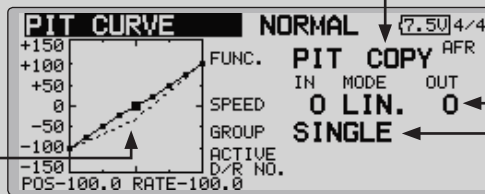

- Pitch trim operating position (dotted line)

- Pitch servo speed setting (For a description of the setting method, see the description at the back of this manual.)

- Group/single mode switching (For more information, refer to the description at the back of this manual.)

#### Normal curve adjustment

- For normal curve, usually use [POINT] type and create a basic pitch curve centered about hovering. Use this function together with the THR curve (normal) function and adjust the curve so that up/down control is best at a constant engine speed.

#### Idle up curve adjustment

- For the high side pitch curve, set the maximum pitch which does overload the engine. For the low side pitch curve, create curves matched to loop, roll, 3D, and other purposes and use the idle up curves according to the performance.

#### Throttle hold curve adjustment

- The throttle hold curve is used when executing auto rotation dives.

### Operation precautions

#### ⚠ WARNING

- When actually starting the engine and flying, always set the idle up condition switch to OFF and start the engine in the idling state.

## Setting method

- Group/Single item: When you also want to input the same setting contents at other conditions, perform setting in the group mode. In this case, the same contents are input to the other conditions set in the group mode. When you want to set each condition independently, select the single mode (initial setting). Other conditions can be set independently.
- Pit trim copy (Hover/high/low)  
The pitch trim operating position can be copied to the pitch curve.  
Move the cursor to the [COPY] item and push the RTN button.  
After copying, return the pitch trim to the center to call the last operating position.

## Curve setting examples

The screens shown below are curves created by entering the pitch rate at low, center, and high side (3 points or 5 points) at each condition. When actually creating a curve, input the rate specified at the fuselage (or the reference value).

\*For a description of the curve setting method, see the description at the back of this manual.

### •Pitch Curve (Example)

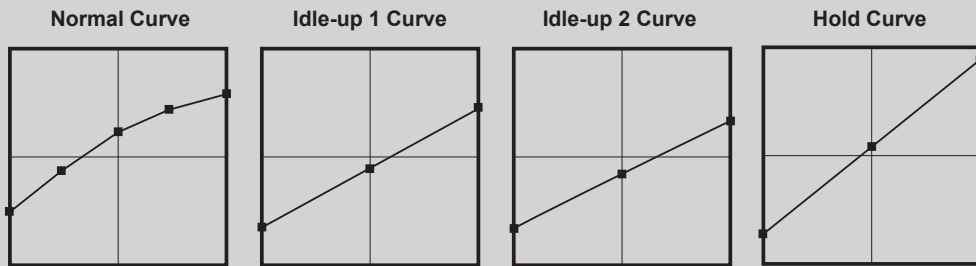

## Pitch Trim (Hovering pitch, high pitch, low pitch)

The hovering pitch, low pitch, and high pitch trim setup screen can be called from the PIT curve setup screen.

- Hovering pitch trim setting

<b>PIT CURVE</b>		<b>NORMAL</b>	7.50 2/4
<b>HOVER</b>			
ACT/INH	ON	MODE	CTRM
GROUP	SINGLE	RANGE	100%
CONTROL	LD		
RATE	+30% < -30%		

- Low/high pitch trim setting

<b>PIT CURVE</b>		<b>NORMAL</b>	7.50 3/4
<b>LOW PITCH</b>		<b>HIGH PITCH</b>	
ACT/INH	INH	ACT/INH	INH
GROUP	SINGLE	GROUP	SINGLE
CONTROL	--	CONTROL	--
RATE	+30% < +0%	RATE	-30% < +0%

(Continued on next page)

## Hovering pitch trim

---

The Hovering Pitch trim function trims the pitch near the hovering point. Normally, it is used with the hovering condition. The hovering pitch can be fine tuned for changes in rotor speed accompanying changes in temperature, humidity, and other flight conditions. Adjust the hovering pitch so that rotor speed is constant. This function can be used together with the hovering Throttle Trim function for more delicate operation.

### Setting method

---

- When using only the hovering (normal) condition, switch the group mode to the single mode (initial setting) before setting.
- Set the function to ACT [ON].
- Select the adjustment knob.
- The trim operation mode (Mode: CTRM/NORM) can be selected.  
CTRM mode: Maximum amount of change near center by center trim operation (recommended)  
NORM mode: Normal trim (parallel movement trim) operation. The advantage of using this mode is that the hovering pitch can be adjusted without changing the curve.
- Trim adjustment range (Range) setting  
When this value is made small, trim can only be used near the center.
- The trim rate can be adjusted and the operation direction can be changed.

## High Pitch/Low Pitch Trim

---

High Pitch/Low Pitch Trim is the pitch servo high side and low side trim function.

### Setting method

---

- When setting the adjustment knobs common to all the conditions, set them in the group mode.
- Set the function to ACT (ON).
- Select the adjustment knobs.
- The trim rate can be adjusted and the operation direction can be changed.
- Trim acts as high side or low side trim with the center as the standard.

## THR CURVE/THROTTLE HOVER TRIM

### THR Curve

This function adjusts the throttle operation curve for each condition for optimum engine speed to throttle stick movement.

Up to 17 curve points can be set for the point curve type, however, when the 5 points and other

point data is used, a simple curve can be easily created by reducing the number of input points of the curve to 5 and entering the specified value at the corresponding points.

- Select [THR CURVE] at the model menu and call the setup screen shown below by pushing the RTN button.

- Select the function name and return to the preceding screen by pushing the RTN button or pushing the Home/Exit button.

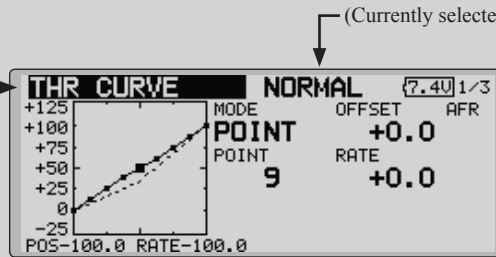

- Mixing curve setting  
\*For a description of the curve setting method, see the description at the back of this manual.

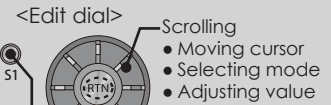

- Push the S1 button to call next page.

### Normal curve adjustment

- Normal curve creates a basic curve centered around hovering. Use it along with the normal pitch curve and adjust so that up/down control at a constant engine speed is easiest.

### Idle up curve adjustment

- Set a idle up curve that maintains a constant speed at all times, even during operation which reduces the pitch performed in flight. Create a curve matched to loop, roll, 3D, or other purposes and the idle up curve according to the performance.

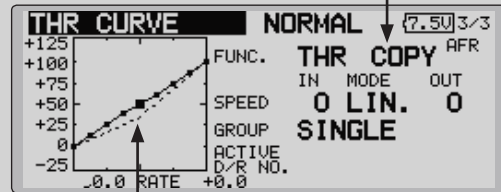

- Throttle hover trim operating position (dotted line)

### Operation precautions

#### ⚠ WARNING

- ! When actually starting the engine and flying, always set the idle up condition switch to OFF and start the engine in the normal/motor at idle mode.

### Setting method

- Group/single item: When you want to simultaneously enter the same settings to other functions, make the settings in the group mode. In this case, the same setting contents are entered to the all conditions. When you want to set each condition independently, make the settings after selecting the single mode (Initial setting).
- Throttle hover trim copy  
The throttle hover trim operating position can be copied to the throttle curve.  
Move the cursor to the [COPY] item and push the RTN button.  
After copying, return the pitch trim to the center to call the last operating position.



## Curve setting examples

The curves shown below are created by using the point curve type and inputting the data of the 5 points 0% (low side), 25%, 50% (center), 75%, 100% (high) side at each condition. They are created by reducing the number points of the line

to 5. When actually creating a curve, enter the data specified per the aircraft (or the reference value).

\*For a description of the curve creation method, see the description at the back of this manual.

### •Throttle Curve (Example)

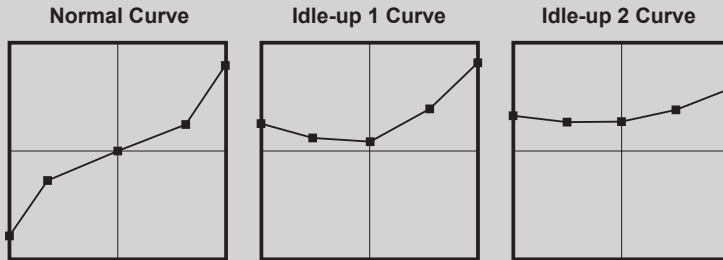

## Throttle Hover trim

The Throttle Hover trim setup screen can be called from the THR Curve setup screen.

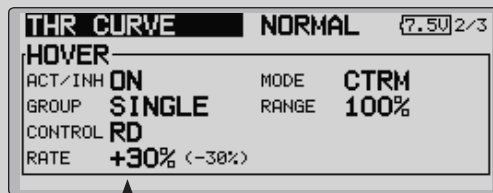

•Sets the dial used.

The Throttle Hover function trims the throttle near the hovering point. Normally, use it with hovering conditions. Changes in rotor speed accompanying changes in the temperature, humidity, and other flight conditions can be trimmed. Adjust the throttle so that rotor rotation is most stable. More delicate trimming is also possible by using this function along with the Hover Pitch function.

CTRM mode: Maximum rate of change near center by center trim operation (recommended)

NORM mode: Normal trim (horizontal movement trim) operation.

- Trim adjustment range (Range) setting  
When the value is made small, trim acts only near the center.
- The trim rate can be adjusted and the operation direction can be set.

### Setting method

- When using the hovering (normal) condition only, switch the group mode to the single mode (initial setting) and make the settings.
- Set the function to ACT ([ON]).
- Select the adjustment knob.
- The trim operation mode (Mode: CTRM/NORM) can be selected.

## Throttle Limiter

This function limits throttle operation to within a certain range. Control which adjusts the operating range during flight can be set. (Effective only when the model type is helicopter.)

\*When the limiter operation range adjustment control is NULL, the throttle limiter function is not activated.

- Open the THR CURVE setup screen. Push S1 button to advance to next page and display page4.

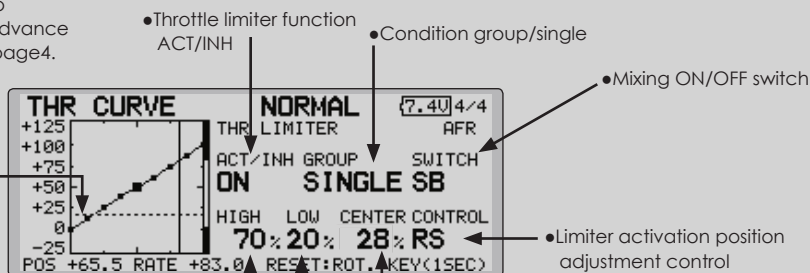

- Throttle limiter activation position

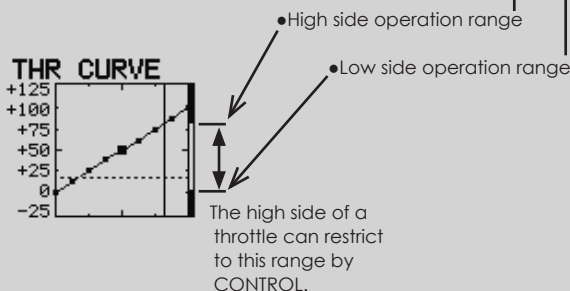

- The limit value at the operation hardware neutral position can be adjusted using the throttle limiter.

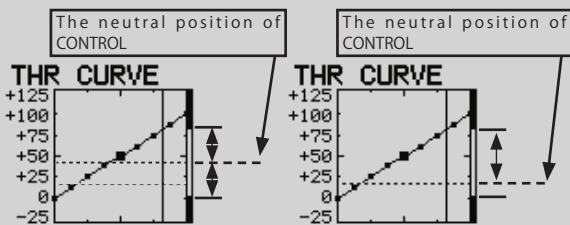

## Setting method

- Activate the function
  1. Select "ACT/INH" and push the RTN button.
  2. Scrolling the edit dial and switch the display to [INH] or [ACT].
  3. Push the RTN button.
- Group/single mode selection.
  1. Select "GROUP" and push the RTN button.
  2. Scrolling the edit dial and switch the display to [GROUP] or [SINGLE].
  3. Push the RTN button.
- ON/OFF switch setting
  1. Select "SWITCH" and push the RTN button.
  2. A hardware selection screen is displayed. Select the hardware and push the RTN button.
- High side operation range setting
  1. Select "HIGH" and push the RTN button.
  2. Scrolling the edit dial and adjust the high side operation range.
- Low side operation range setting
  1. Select "LOW" and push the RTN button.
  2. Scrolling the edit dial and adjust the low side operation range.
  3. Push the RTN button.
- The neutral position of "CONTROL" setting
  1. Select "CENTER" and push the RTN button.
  2. Scrolling the edit dial and adjust the neutral position.
  3. Push the RTN button.
- Limiter activation position adjustment control setting
  1. Select "CONTROL" and push the RTN button.
  2. A hardware selection screen is displayed. Select the hardware and push the RTN button.

## ACCELERATION

This function is used to adjust the pitch and the throttle rise characteristic at acceleration/deceleration operation. An acceleration function which temporarily increases the pitch and throttle operations at throttle stick acceleration/deceleration operation can be set.

### Example of acceleration function use

- When used for pitch control, the acceleration function is effective when you want to quicken the response of the model at 3D on collective pitch. When used, high pitch temporarily exceeds maximum pitch, but immediately returns to maximum pitch.

- Select [ACCELERATION] at the model menu and call the setup screen shown below by pushing the RTN button.

- Select the function name and return to the preceding screen by pushing the RTN button or pushing the Home/Exit button.

- Pitch setting

- Throttle setting

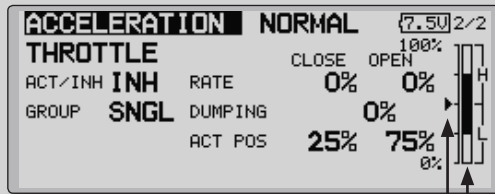
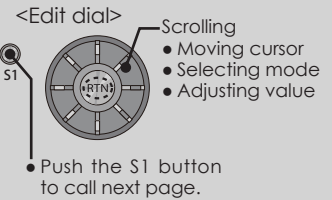
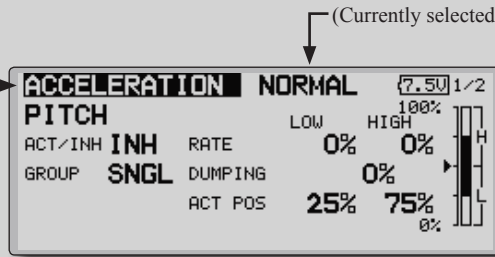

- Act position
- Current position

### Setting method

- Acceleration can be set at both setting at acceleration (high) and setting at deceleration (low).  
(The operation point is displayed on a graph.)
- Acceleration rate setting (Rate)
- The return time after operation (Dumping) can be set.
- The operation point at acceleration and deceleration can be set. When an operation point is exceeded, acceleration is performed.

Note: When using the acceleration function, since the pitch stroke is large, make your settings so there is no binding of your linkage.

## THR HOLD

This function sets the throttle cut position for auto rotation. The throttle position can also be set to an idling position. Setting of these 2 positions can be selected by a switch. This allows use for switching during training.

- Select [THR HOLD] at the model menu and call the setup screen shown below by pushing the RTN button.

- Select the function name and return to the preceding screen by pushing the RTN button or pushing the Home/Exit button.

- Set to the engine stop position.

- Set to the idling position.

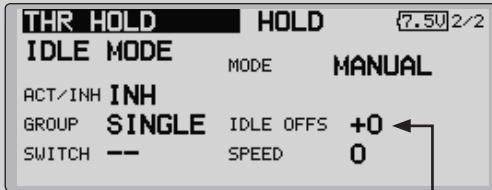

### Example of use

- Since throttle hold has 2 modes (Cut) and (Idle), using it in the Idling mode during training and in the Cut mode when stopping the engine.

Note: When throttle hold is set to ON in the normal condition, throttle hold acts and the throttle servo is deactivated. Always set throttle hold to ON in the hold condition.

(Currently selected condition name)

<Edit dial>

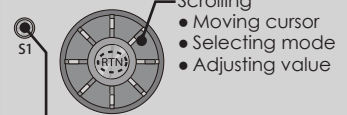

- Push the S1 button to call next page.

- Hold position

- Current position

### Setting method

- Operation mode selection

Manual mode(MANUAL): The throttle hold function is operated by switch operation only.

Auto mode(AUTO): The throttle hold function operation is linked to the throttle stick position.

Auto position setting: When the auto mode is selected, the throttle position (auto position) can be selected. Move the throttle stick to the position you want to set and push the RTN button. (Auto position is displayed.)

- Hold position adjustment

Throttle Hold (Cut) sets the throttle cut position. Adjust it so that the carburetor is full close.

Throttle Hold (Idle): Make this adjustment to maintain idling. Adjustments can be made based on the throttle curve idle position.

- The throttle servo operating speed can be adjusted. (Speed)
- Throttle cut or training function can be switched by hold function selector switch.

### Operation precautions

#### ⚠ WARNING

- When starting the engine, confirm that the idle up condition and throttle hold condition are OFF.

## SWASH MIX

The swash mix function is used to correct the swash plate in the aileron (roll) direction and elevator (cyclic pitch) corresponding to each operation of each condition.

Adjustment by independent curve for aileron, elevator, and pitch operations is possible. The operation can be smoothly adjusted by calling up the "Curve setup" screen by pushing the EDIT button with moving the cursor to the mixing item that corresponds to the mixing and direction which needs correction.

### Example of use

- As an example, use swash mixing to correct undesirable tendencies in the roll direction
- For a condition which uses AIL to ELE, set this function to ON. When raising the nose at a right roll, when the Rate B side is input and the right aileron is operated, the elevator moves to the down side. Tune by adjusting the Rate. For right roll, adjust to the rate A side.

- Select [SWASH MIX] at the model menu and call the setup screen shown below by pushing the RTN button.

- Select the function name and return to the preceding screen by pushing the RTN button or pushing the Home/Exit button.

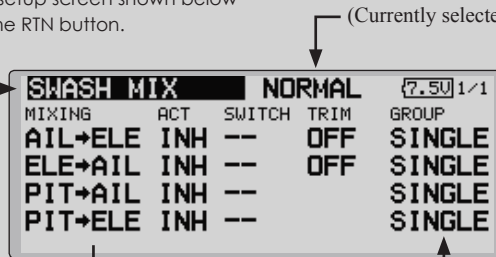

(Currently selected condition name)

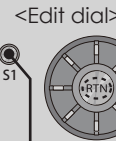

- Scrolling
- Moving cursor
- Selecting mode

- Push the S1 button to call next page.

- Group/single mode switching

(For more information, refer to the description at the back of this manual.)

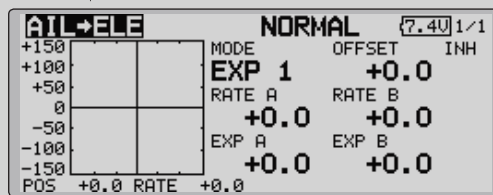

- Mixing curve setting

\*For a description of the curve setting method, see the description at the back of this manual.

### Setting method

- When using this function, move the cursor to the [ACT] item and push the RTN button to switch to the data input mode. Turn the edit dial to the left and push the RTN button. (ON is displayed.)
- When you want to set the same contents at other conditions, select the group mode. When you want to set the selected condition only, select the single mode (initial setting).
- The correction rate can be set by curve.
- A switch can be set.

When [--] is set, the swash mixing function is operated by merely selecting the condition.

When setting an [ON]/[OFF] switch, move

the cursor to the [--] item and push the RTN button to call the selection screen and set the switch and its ON position.

## THROTTLE MIX

This function corrects slowing of engine speed caused by swash plate operation during aileron or elevator operation. The method of applying clockwise or counterclockwise torque when pirouetting can also be corrected.

An acceleration function which temporarily increases the throttle side correction rate relative to rapid stick operation can also be set.

- Select [THROTTLE MIX] at the model menu and call the setup screen shown below by pushing the RTN button.

When correction is necessary, move the cursor to the mixing item corresponding to the mixing that needs correction and push the RTN button to call the curve setup screen, and then correct the slowing.

### Setting example

- ALL to THR applies a load to the engine and corrects slowing of the engine speed when the aileron stick was operated. Engine racing can be adjusted independently at the right aileron and left aileron by Rates A and B.

(Currently selected condition name)

- Select the function name and return to the preceding screen by pushing the RTN button or pushing the Home/Exit button.
- Mixing curve setting  
\*For a description of the curve setting method, see the description at the back of this manual.

<Edit dial>

- Scrolling
- Moving cursor
- Selecting mode

• Push the S1 button to call next page.

• Group/single mode switching

(For more information, refer to the description at the back of this manual.)

THROTTLE MIX NORMAL [7.50] 1/1

MIXING	ACT	SWITCH	MODE	GROUP
AIL→THR	INH	--	CTRM	SINGLE
ELE→THR	INH	--	CTRM	SINGLE
RUD→THR	INH	--	CTRM	SINGLE

AIL→THR NORMAL [7.40] 1/2

MODE	EXP 1	OFFSET	INH
RATE A	+0.0	RATE B	+0.0
EXP A	+0.0	EXP B	+0.0

POS +0.0 RATE +0.0

AIL→THR NORMAL [7.40] 2/2

INH

RATE	LEFT	RIGHT
DUMPING	0%	0%
ACT POS	-50%	+50%

• Acceleration settings

### Setting method

- When using this function, move the cursor to the [ACT] item and push the RTN button to switch to the data input mode. Turn the edit dial to the left and push the RTN button. (ON is displayed.)
- When you want to set the same contents at other conditions, select the group mode.  
When you want to set the selected condition only, select the single mode (initial setting).
- The correction rate can be set by curve.
- A switch can be set.

When [--] is set, the swash mixing function is operated by merely selecting the condition.

When setting an [ON]/[OFF] switch, move the cursor to the [--] item and push the RTN button to call the selection screen and set the switch and its ON position.

### <Acceleration function setting>

- Acceleration can be set for both settings (Left) and (Right)
- Acceleration rate setting (Rate)
- The return time (Dumping) after operation can be set.
- The operation point when the correction rate is increased and decreased can be set independently. When an operation point is exceeded, acceleration operation is performed.

## PIT to NEEDLE MIXING

This mixing is used when the engine is equipped with needle control or other fuel-air mixture adjustment. A needle curve can be set.

An acceleration function which temporarily increases needle operation at throttle stick

acceleration/deceleration operation can be set. The rise characteristic of the needle servo at acceleration and deceleration operation can be adjusted.

- Select [PIT to NEEDLE] at the model menu and call the setup screen shown below by pushing the RTN button.

- Normally, use [POINT] type.

- Select the function name and return to the preceding screen by pushing the RTN button or pushing the Home/Exit button.

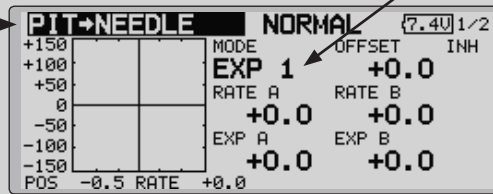

<Edit dial>

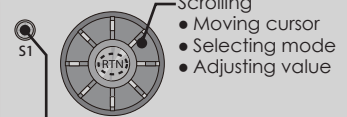

- Push the S1 button to call next page.

- Mixing curve setting

\*For a description of the curve setting method, see the description at the back of this manual.

- Group/single mode switching

(For more information, refer to the description at the back of this manual.)

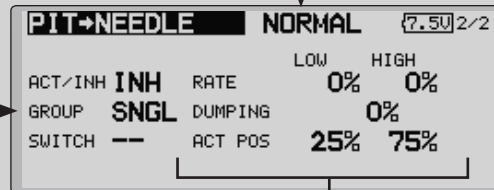

- Acceleration settings

### Setting method

- When using this function, move the cursor to the [ACT] item and push the RTN button to switch to the data input mode. Turn the edit dial to the left and push the RTN button. (ON is displayed.)
- When you want to set the same contents at other conditions, select the group mode. When you want to set the selected condition only, select the single mode (initial setting).
- A needle curve can be set.
- A switch can be set.

When [--] is set, the mixing function is operated by merely selecting the condition.

When setting an [ON]/[OFF] switch, move the cursor to the [--] item and push the RTN button to switch to the data input mode. Push the RTN button to call the selection screen and set the switch and its ON position.

### < Acceleration function setting >

- Acceleration can be set at both setting at acceleration (high) and setting at deceleration (low).
- The acceleration rate (rate) and the return time after operation (dumping) can be set.
- An operation point (act pos) at acceleration and deceleration can be set. When an operation point was exceeded, acceleration operation is performed.

## PIT to RUD MIXING (REVOLUTION MIXING)

Use this mix when you want to suppress the reaction torque generated by main rotor pitch and speed changes during pitch operation. Adjust so that the nose does not move in the rudder direction.

An acceleration function which temporarily increases the correction rate at throttle stick acceleration/deceleration operation can be set. The mixing rate at acceleration/deceleration can be set.

However, when a GY Series or other heading hold gyro is used, since correction is performed by the gyro, this mix is not used. If this function is used when the gyro operation mode is the AVCS mode, the neutral position will change.

- Select [PIT to RUD] at the model menu and call the setup screen shown below by pushing the RTN button.

- Select the function name and return to the preceding screen by pushing the RTN button or pushing the Home/Exit button.

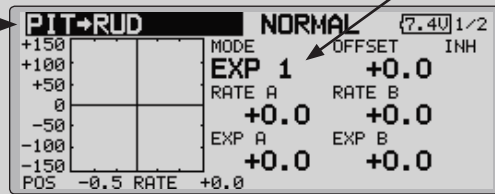

- Normally, use [POINT] type.

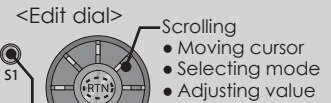

- Push the S1 button to call next page.

### Setting method

- When using this function, move the cursor to the [ACT] item and push the RTN button to switch to the data input mode. Turn the edit dial to the left and push the RTN button. (ON is displayed.)
- When you want to set the same contents at other conditions, select the group mode.  
When you want to set the selected condition only, select the single mode (initial setting).
- A mixing curve is set.

(Currently selected condition name)

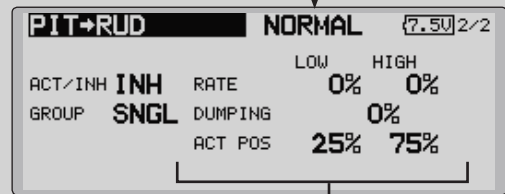

- Acceleration settings

#### <Normal condition mixing curve>

The mixing curve rate starts from a small value.

For a rotor with a clockwise operation direction (polarity), when pitch was operated at the plus side, set so that mixing is in the clockwise direction. First, trim at hovering and then adjust the neutral position.

1. Adjustment between slow and hovering  
Repeatedly hover from take off and land from hovering at a constant rate matched to your own rhythm, and adjust the pitch so the nose does not deflect when the throttle is raised and lowered.
2. Throttle high side (climbing and diving from hovering)  
Repeat climbing and diving from hovering at a constant rate matched to your own rhythm and adjust the pitch so that the nose does not deflect when the throttle is raised and lowered.

#### <Idle up condition mixing curve>

Set the mixing rate so that the rudder direction at high-speed flight is straight ahead. Adjust for each condition used.

#### <Acceleration function setting>

- Acceleration operation can be performed for both setting at acceleration (high) and setting at deceleration (low).
- Acceleration rate setting (rate)
- The return time after operation (dumping) can be set.
- An operation point (act pos) at acceleration and deceleration can be set independently. When an operation point was exceeded, acceleration operation is performed.



## GYRO PROGRAMMING / GAIN SENSITIVITY

This function used to adjust gyro sensitivity. The sensitivity and operation mode (Normal mode/AVCS mode) can be set for each condition.

The gyro sensitivity can be switched with each condition or the switch. (5 sensitivities)

\*Compatible with 3 axis gyro (CGY750).

Note: When using the [Gyro2]/[Gyro3] function, assign [Gyro2]/[Gyro3] to any channel on the function screen.

Always set to [-] both (control) and (trim) for the [Gyro] function at the Function menu in the Linkage menu.

- Select [GYRO] at the model menu and call the setup screen shown below by pushing the RTN button.

- Select the function name and return to the preceding screen by pushing the RTN button or pushing the Home/Exit button.

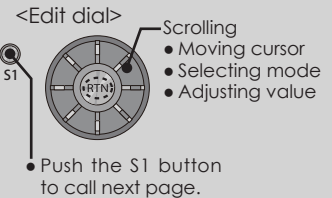
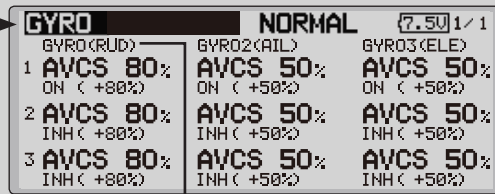

- When the GYRO function button is selected, each GYRO detailed setting screen appears.

(Rate No. display)      (Currently selected condition name)

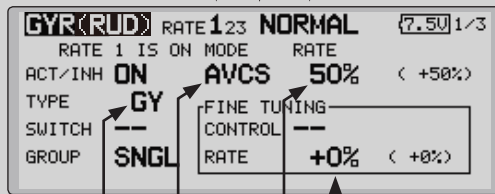

- Gyro type selection: [GY]/[NORM]
- Mode selection: [AVCS]/[NORM]
- Gyro sensitivity adjustment
- Fine tuning VR settings

### Setting method

- When using this function, move the cursor to the [ACT] item and push the RTN button to switch to the data input mode. Turn the edit dial to the left and push the RTN button. (ON is displayed.)
- When you want to set the same contents at other conditions, select the group mode. When you want to set the selected condition only, select the single mode (initial setting).
- Three rates can be switched for each condition. (Rate 1/Rate 2/Rate 3)
- A fine tuning VR can be set.

## GOVERNOR PROGRAMMING

When using a Futaba governor, this function is used to switch the RPM of the helicopters head. Up to 3 rates can be set for each condition.

\*The governor is used by connecting the governor speed setting channel to CH7 (initial setting).

\*When using an independent governor [ON]/[OFF] switch, connect the AUX([ON]/[OFF]) connector of the governor to CH8 (initial setting) and set the switch to CH8 (Governor2) at the Function menu of the Linkage Menu.

\*When using the Fuel Mixture function, the mixture servo is controlled from the governor. When transmitting the mixture curve data from the transmitter to the governor, the governor AUX (m.trm) connector must be connected to CH8 (initial setting) and governor side setting performed. See the governor instruction manual.

Note: Always set (Control) and (Trim) to [-] for [Governor] and [Governor 2] of the Function menu of the Linkage menu.

- Select [GOVERNOR] at the model menu and call the setup screen shown below by pushing the RTN button.

- Select the function name and return to the preceding screen by pushing the RTN button or pushing the Home/Exit button.

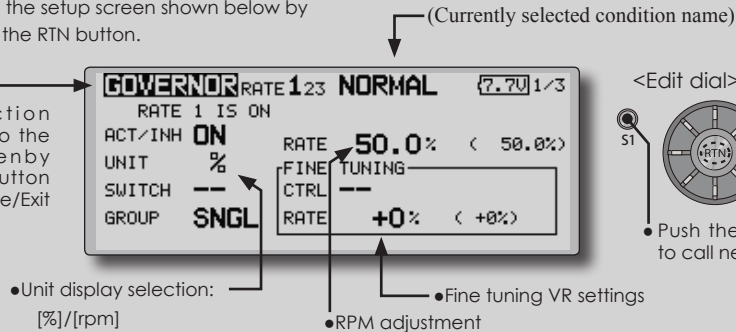

- <Edit dial>
- Scrolling
  - Moving cursor
  - Selecting mode
  - Adjusting value
- S1
- Push the S1 button to call next page.

### Setting method

#### • Activate the mixing

When using this function, move the cursor to the [INH] item and push the RTN button to switch to the data input mode.

Select the ACT mode by scrolling the edit dial.

\*The display blinks.

Push the RTN button to activate the mixing and return to the cursor mode. (ON is displayed.)

When the Governor is changed from the default inhibited (INH) state to the active (ACT) state, the endpoint menu will be displayed and it is possible to utilize the endpoints for this given condition.

\*When the function is set ON/OFF at the governor setup screen, the governor rpm setting channel end point servo travel and limit point are now initialized.

\*When changed from INH to ACT (ON), the servo travel is initialized to 100 and the limit point is initialized to 155.

\*When operation is changed to INH at all conditions, the servo travel is initialized to 100 and the limit point is initialized to 135.

#### • RPM adjustment

Move the cursor to the rate item and push the RTN button to switch to the data input mode.

Adjust the rpm by scrolling the edit dial.

Initial value: 50% (1500rpm)

Adjustment range: OFF, 0~110% (OFF, 700~3500rpm)

\*When the RTN button is pushed for one second, the sensitivity is reset to the initial value.)

Push the RTN button to return to the cursor mode.

#### • Unit display selection

Move the cursor to the UNIT item and push the RTN button to switch to the data input mode. Select the unit by scrolling the edit dial.

Push the RTN button to change the operation mode and return to the cursor mode.

## ●Display mode selection

\*When [rpm] mode is selected above setting, the display mode can be selected.

\*There is no change in the transmitter output even when the "MODE" is changed. Calibration should be performed via the governor.

\*In order to use the Governor function of the FMT-03, it is necessary to change the settings on the governor for the low side 700 rpm mode.

When the MODE of the Governor screen's model menu is changed, the change is also indicated on-screen.

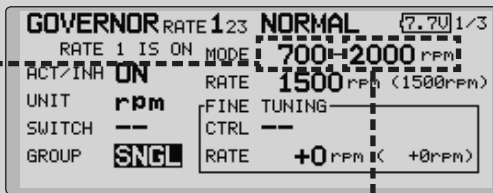

The chart below indicates the mode percentage and the corresponding RPM.

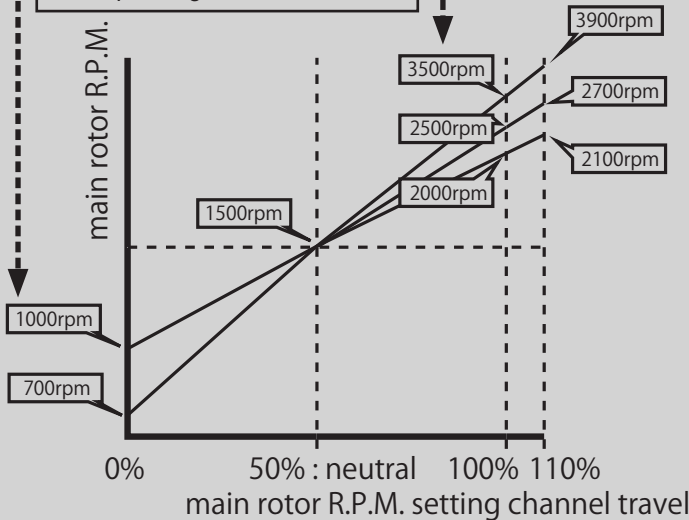

## ●Fine tuning VR settings

Move the cursor to the [-] item and push the RTN button to access the selection screen. Select the control.

\*For a description of the switch selection method, see the description at the back of this manual.

Move the cursor to the rate item and push the RTN button to switch to the data input mode.

Adjust the trim rate by scrolling the edit dial.

Initial value: 0% (0rpm)

Adjustment range: -20~+20% (-800~+800rpm)

\*When the RTN button is pushed for one second, the sensitivity is reset to the initial value.)

Push the RTN button to return to the cursor mode.

## COND.HOLD

Condition hold function

This function may be used to fix the maximum speed of the engine so that you may adjust flight conditions when the engine is running. An alarm indicates that the function is operating. It will prevent the engine from increasing when adjusting the idle-up settings.

While this function is active, the throttle servo position is fixed at the point set from when the function is activated. You must deactivate this function when you are through making adjustments.

The system will not allow you to activate/deactivate this function in either of the following states:

- When any of the flight condition switches are on.
- When the throttle stick is higher than the 1/3 point.

### To activate/deactivate condition hold:

#### (Home screen)

1. Move the cursor to [CND HOLD].
2. Set the throttle stick lower than the 1/3 point.
3. Push the RTN button to activate the condition hold function.

\*When this function is active, "IS ON" appears at the right of the [CND HOLD] display at the left bottom of the screen.

#### (LINKAGE menu/MODEL menu)

1. Move the cursor to [COND. HOLD].
2. Set the throttle stick lower than the 1/3 point.
3. Push the RTN button to activate the condition hold function.

\*Operation is displayed at the bottom of the menu.

Function ON: "CND HOLD IS ON" is displayed.

Function OFF: "CND HOLD IS OFF" is displayed.

## SWASH RING

< Linkage Menu >

Limits the swash plate travel to within a fixed range. (Helicopter only)

This function limits the swash travel to within a fixed range to prevent damaging of the swash linkage by simultaneous operation of the ailerons and elevators. It is effective in 3D aerobatics which use a large travel.

- Select [SWASH RING] at the linkage menu and call the setup screen shown below by pushing the RTN button.
- Select the function name and return to the preceding screen by pushing the RTN button or pushing the Home/Exit button.
- The operating range display area: The vertical direction shows the elevator travel. The horizontal direction shows the aileron travel.
- The marker shows the stick position.
- When the swash ring function is activated, a circle is displayed in the operating range display area and the rate input box is displayed. Stick operation is limited to within the area of this circle.

### Swash ring setting procedure

\*Perform the following settings after using the edit dial to move the cursor to the item you want to set.

#### 1. Activate the function:

Move the cursor to the [ACT/INH] item and push the RTN button to switch to the data input mode.

Switch the blinking from "INH" to "ACT" by turning the edit dial to the left and then push the RTN button.

#### 2. Rate setting:

Use the edit dial to move the cursor to the [RATE] item push the RTN button to switch to the data input mode.

Use the edit dial to set the rate.

Initial value: 100%.

Adjustment range: 50% to 200%.

\*Adjust the rate to maximum swash tilt.

(When the RTN button is pushed for 1 second, the rate is reset to the initial value.)

Push the RTN button to end adjustment and return to the cursor move mode.

## SWASH

< Linkage Menu >

Swash operation linkage correction function. (helicopter only, except swash type H-1)

### Neutral Point

At your linkages, if the servo horn deviates from a perpendicular position at neutral, the linkage compensation functions in this menu may not compensate effectively. To correct this use the neutral point function. This will move the neutral point of the servos to the actual perpendicular position. However, this adjustment changes only the axis point of the compensation functions in this menu, and does not affect the neutral position of other functions.

### Swash AFR

Swash AFR function reduces/increases/reverses the rate (travel) of the aileron, elevator and collective pitch functions, by adjusting or reversing the motion of all servos involved in that function, only when using that function.

### Mixing Rate

This compensation mixing is used to correct the tendency of the swash-plate for each control. The following compensation mixing is possible; PIT to AIL, PIT to ELE, AIL to PIT, ELE to AIL, and ELE to PIT (HR3 mode.) It adjusts the swash-plate to operate correctly for each control using the corresponding compensation mixing.

### Linkage Compensation

This compensation mixing is used to correct the tendency of the swash-plate for pitch control at low pitch and high pitch.

### Speed Compensation

This function is used to cancel the reaction that is generated by the difference of the operation amount of each servo when the swash-plate moves.

- Select [SWASH] at the linkage menu and call the setup screen shown below by pushing the RTN button.

- Select the function name and return to the preceding screen by pushing the RTN button or pushing the Home/Exit button.

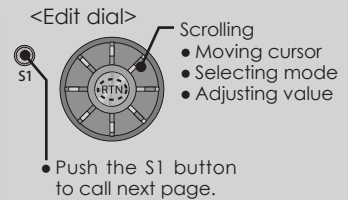
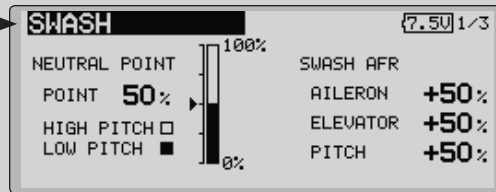

- \*Before making the following settings, use the edit dial to move the cursor to the item you want to set.

### Neutral point setting procedure

The neutral point becomes the correction standard point.

- \*Adjusting the servo horn so that the neutral point is near the 50% position makes the mixing amount small.

#### 1. Neutral point setting

Move the cursor to the [POINT] item and hold the pitch operation so that the servo horn is at a right angle to the linkage rod and push the RTN button for 1 second and read the neutral position.

- \*The neutral point can also be displayed by bar graph.

After reading the neutral point, use the other correction functions to make further adjustments.

### Swash AFR setting procedure

The swash AFR function makes adjustments so that the servos travel the specified amount by [AILERON], [ELEVATOR], and [PITCH] operation.

1. Use the edit dial to move the cursor to the function you want to adjust and push the RTN button to switch to the data input mode.

2. Adjust the AFR rate by turning the edit dial to the left or right.

Initial value: +50%

Adjustment range: -100%~+100%

(When the RTN button is pushed for 1 second, the AFR rate is reset to the initial value.)

Push the RTN button to end adjustment and return to the cursor move mode.

## Mixing rate setting procedure

The HR-3 is taken as an example to describe mixing rate setting. Mixing applied in other swash modes is different, but the setting procedure is the same.

SWASH		(7.50) 2/3	
MIXING RATE			
MIXING	←+↻ ↻+→	MIXING	←+↻ ↻+→
PIT→AIL	100% 100%	AIL→PIT	100% 100%
PIT→ELE	100% 100%	ELE→AIL	50% 50%
		ELE→PIT	50% 50%

\*Set the throttle stick to the preset neutral point. Adjust the length of the linkage rod so that the swash plate is horizontal at this position.

\*The sub trim function can be used to make small adjustments.

\*Adjust so that the pitch curve is a straight line and pitch operation is maximum.

\*When making the following setting, use the edit dial to move the cursor to the item you want to set and push the RTN button to switch to the data input mode. Push the RTN button to end adjustment and return to the cursor move mode.

### 1. Adjustment at aileron operation [AIL to PIT]

Adjust the AIL to PIT rate so there is no interference in the elevator or pitch direction when the aileron stick is moved to the left and right.

\*Adjust by turning the edit dial to the left or right.

\*The left and right sides can be adjusted individually.

### 2. Adjustment at elevator operation [ELE to AIL]/[ELE to PIT]

Adjust the ELE to AIL and ELE to PIT rates so there is no interference in the aileron or pitch direction when the elevator stick is moved up and down.

\*Adjust by turning the edit dial to the left and right.

\*The up and down sides can be adjusted individually.

### 3. Adjustment at pitch operation [PIT to AIL][PIT to ELE]

Adjust the PIT to AIL and PIT to ELE rates so that the swash plate moves to the horizontal position when the throttle stick was moved to maximum slow and full high.

\*Adjust by turning the edit dial to the left and right.

\*The slow and high sides can be adjusted individually.

## Linkage compensation setting procedure

\*Perform linkage compensation setting after mixing rate setting.

\*Linkage compensation compensates for interference by aileron operation with the elevator or elevator operation with the aileron at collective pitch control for low pitch and high pitch.

SWASH		(8.80) 3/3	
LINKAGE COMPENSATION			
FUNCTION	DIR.	LOW PITCH ↻+→ ↻+→	
AILERON	+	0%	0%
ELEVATOR	+	0%	0%
SPEED COMPENSATION 0			

\*When making the following setting, use the edit dial to move the cursor to the item you want to set and push the RTN button to switch to the data input mode. Push the RTN button to end adjustment and return to the cursor move mode.

### 1. Compensation at aileron operation [AILERON]

Set the throttle to the maximum slow position. Move the aileron stick to the left and right and adjust the aileron compensation amount so that interference in the elevator or pitch direction at that time is minimum.

\*Adjust the edit dial to the left and right.

\*The left and right sides can be adjusted individually.

\*When the interference increases when the compensation amount was increased, make adjustments with the compensation direction [DIR] as "-".

### 2. Compensation at elevator operation [ELEVATOR]

Adjust the elevator compensation amount so that the aileron or pitch direction interference when the elevator stick was moved up and down is minimum.

3. Regarding steps 1 and 2 above, perform aileron and elevator compensation similarly at the full high side of the throttle stick also.

## Speed compensation setting procedure

1. Use the edit dial to move the cursor to the "SPEED COMPENSATION" item and push the RTN button to switch to the data input mode.

2. Set the throttle stick to the neutral point position. Quickly move the elevator stick and adjust the speed compensation amount [SPEED COMPENSATION] for minimum interference in the pitch direction.

\*Adjust by turning the edit dial to the left and right.

Push the RTN button to end adjustment and return to the cursor move mode.

# FMT-03

## Futaba®