

R6308SBT *FASST-2.4GHz (7ch/8ch/10ch/Multi-ch) System with Telemetry* *S.BUS2 / S.BUS Port and 8 Channels for Conventional System Receiver*

1M23N17459

Thank you for purchasing a Futaba **R6308SBT FASST-2.4GHz** compatible receiver. The **R6308SBT** receiver features bi-directional communication with a telemetry receiver unit (option) using the **S.Bus2** port. Using the **S.Bus2** port an impressive array of telemetry sensors may be utilized. It also includes both standard PWM output ports and S.Bus output ports. This receiver distinguishes automatically FASST-2.4-GHz system 7ch or Multi-ch/10ch / 8ch mode at the time of link operation with a transmitter. And high speed mode can be chosen.

Applicable systems: Futaba FASST-2.4GHz (7ch/8ch/10ch/Multi-ch) system transmitter

Usage precaution

⚠ WARNING

- ⊘ Changes or modification not expressly approved by the party responsible for compliance could void the user's authority to operate the equipment.
- ⚠ The R6308SBT receiver should be protected from vibration by foam rubber, Velcro or similar mounting methods. Protect from moisture.
- ⊘ Keep away from conductive materials to avoid short circuits.
- ⊘ Don't connect to Extra Voltage before turning on a receiver.

Antenna installation precaution

- ⊘ Do not cut or bundle the receiver antenna wire.

- ⊘ Do not bend the coaxial cable. It causes damage.
- ⊘ The antennas must be mounted in such a way to assure they are strain relieved.
- ⚠ Keep the antenna as far away from the motor, ESC and other noise sources as you possibly can.
- ⚠ Be sure that the two antennas are placed at 90 degrees to each other.
- The R6308SBT has two antennas. In order to maximize signal reception and promote safe modeling Futaba has adopted a diversity antenna system. This allows the receiver to obtain RF signals on both antennas and fly problem-free.

Antenna installation for carbon fuselage

⚠ WARNING

- ⚠ You must leave 30mm at the tip of the antenna fully exposed. The exposed antenna should be secured so that it cannot move around or back inside of your aircraft.

(Antenna installation)

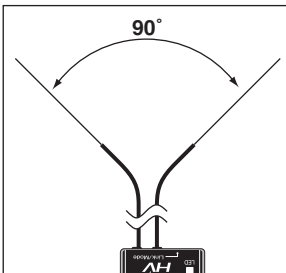

Extra Voltage Port

It connects with the battery for power, etc. **External voltage input cable of an option** is used. The voltage of the battery can be displayed with a transmitter.

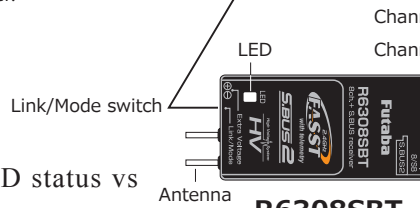
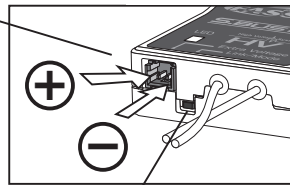

R6308SBT

Battery to 7/B

(Typical installation)

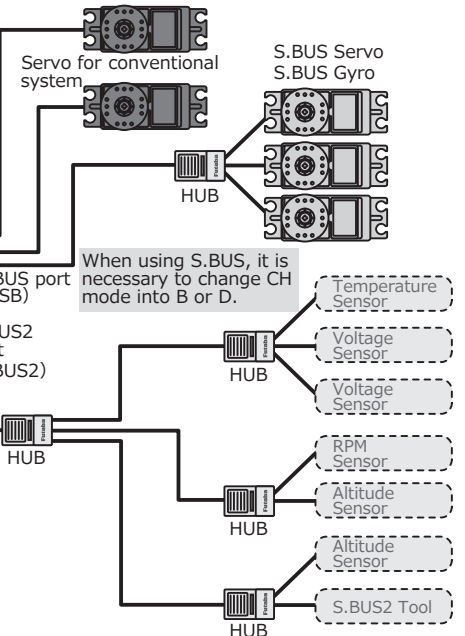

Please refer the table below for LED status vs receiver's condition.

LED Indication

Green	Red	Status
Off	Solid	No signal reception
Solid	Off	Receiving signals
blink	Off	ID of a signal is disagreement
Alternate blink		Unrecoverable error (EEPROM, etc.)

Compliance Information Statement (for U.S.A.)

This device, trade name Futaba Corporation of America, model number R6308SBT, complies with part15 of the FCC Rules. Operation is subject to the following two conditions:

- (1) This device may not cause harmful interference, and
 - (2) This device must accept any interference received, including interference that may cause undesired operation.
 - (3) This module meets the requirements for a mobile device that may be used at separation distances of more than 20cm from human body.
- To meet the RF exposure requirements of the FCC this device shall not be co-located with another transmitting device.

The responsible party of this device compliance is:
Futaba Service Center
3002 N Apollo Drive Suite 1, Champaign, IL 61822 U.S.A.
TEL (217)398-8970 or E-mail: support@futaba-rc.com (Support)

R6308SBT Specifications

FASST-2.4GHz system(7CH/8CH/10CH/Multi-ch mode)/S.BUS2 and S.BUS port and 8 channels for conventional system receiver

- Dual antenna diversity
- Size: 0.98 x 1.86 x 0.56 in. (24.9 x 47.3 x 14.3 mm)
- Weight: 0.38 oz. (10.9g)
- Power requirement: 3.7V to 7.4V(Voltage range: 3.5 to 8.4V)
- Battery F/S Voltage: 3.8V *The Battery F/S voltage is set for 4-cell NiCd/NiMH battery. Battery F/S function doesn't work properly when other type battery is used.
- Extra Voltage port: 0 ~ 70V DC

* Be sure that when using ESCs regulated output the capacity of the ESC must meet your usage condition.

S.BUS2

S.BUS2 extends S.BUS and supports bidirectional communication. Sensors are connected to the S.BUS2 port. Sensor information is transmitted to telemetry receiver unit by which the option is carried out.

*Only S.Bus2 capable devices may be connected to the S.Bus2 port. Standard S.Bus servos and gyros should not be connected to the S.Bus2 port.

Link to the transmitter

1 Press and hold the **Link/Mode** switch more than two(2) seconds.

Re-adjust the 3CH F/S position (only for TM-8)

1 Press and hold the **Link/Mode** switch between one(1) and two(2) seconds.

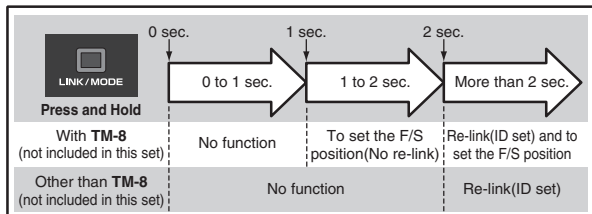

* If there are many FASST systems turned on in close proximity, your receiver might have difficulty establishing a link to your transmitter. This is a rare occurrence. However, should another FASST transmitter/receiver be linking at the same time, your receiver could link to the wrong transmitter. This is very dangerous if you do not notice this situation. In order to avoid the problem, we strongly recommend you to double check whether your receiver is really under control by your transmitter.

⚠ WARNING

Do not perform the linking procedure while the motor's main wire connected or the engine is operating as it may result in serious injury.

When the linking is complete, please cycle the receiver power and ensure the receiver is properly linked to the transmitter.

Please power up your system in this order. Transmitter first, followed by the receiver.

Channel Modes

The R6308SBT is capable of changing its channel allocations as described in the table below.

- Press and hold down the Link/Mode button on the R6308SBT receiver.
- Turn the receiver on while holding down the Link/Mode button. After power up, the button can be released.
- The LED should now be blinking red in one of the patterns described by the chart below.
- Each press of the Mode/Link button advances the receiver to the next mode.
- When you reach the mode that you wish to operate in, press and hold the Mode/Link button for more than 2 seconds.
- Once locked into the correct mode the LED will change to a solid color.
- Please cycle the receiver(s) power off and back on again after changing the Channel Mode.

R6308SBT CH Mode table

Output connector	Channel			
	Mode A 1 ~ 8CH	Mode B 1 ~ 7CH	Mode C 9 ~ 16CH	Mode D 9 ~ 15CH
1	1	1	9	9
2	2	2	10	10
3	3	3	11	11
4	4	4	12	12
5	5	5	13	13
6	6	6	14	14
7/B	7	7	15	15
8/SB	8	S.BUS	16	S.BUS
Red LED blink	1 time	2 time	3 time	4 time

High speed mode / Telemetry ON, OFF

R6308SBT can perform the change of high speed mode and a normal mode. A response becomes high-speed, however the high speed mode cannot use a sensor. Only receiver battery voltage transmits.

Mode and Telemetry	
Operation Mode	Telemetry
Normal	Receiver battery voltage, Sensor
High speed	Only receiver battery voltage

- Turn the receiver on.
- Press and hold down the Link/Mode button on the R6308SBT receiver.
- A button will be released, It held for 10 seconds and LED became red high-speed blink.

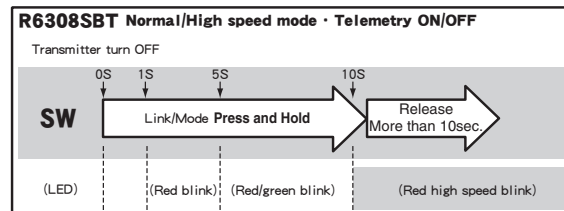

- Each press of the Mode/Link button advances the receiver to the next mode.
- When you reach the mode that you wish to operate in, press and hold the Mode/Link button for more than 2 seconds.
- Once locked into the correct mode the LED will change to a red green simultaneous blink.
- Please cycle the receiver(s) power off and back on again after changing the Channel Mode.

*If you use two receivers by one model, please make Telemetry ON into one set.

Receiver Mode table				
Mode	Normal		High speed	
Telemetry	ON	OFF	ON	OFF
Green LED blink	1time	2time	3time	4time

Link to the Telemetry Receiver Unit (option)

Since it links with telemetry receiver unit (option), R6308SBT is made into ID transmitting mode.

- Turn the receiver on.
- Press and hold down the Link/Mode button on the R6308SBT receiver.
- A button will be released, It held for 5 seconds and LED became red green blink .

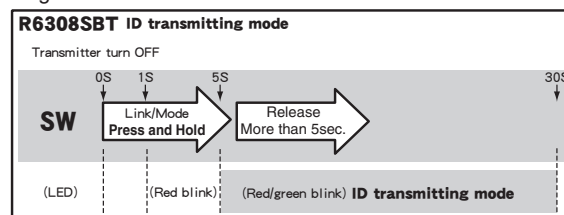

- Red green blink of the R6308SBT is carried out, and it goes into ID transmitting mode for 30 seconds.
- Telemetry receiver unit (option) is linked between ID transmitting mode.

*Refer to the manual of telemetry receiver unit (option) for link operation of telemetry receiver unit .

When S.BUS is used

* Set the channel of **S.BUS** servos by using an **SBC-1** channel changer, **CIU-2** USB serial interface or the programming software resident in the **18MZ** transmitter.

* Can also be used together with conventional servos. However, conventional servos cannot be used by the **S.BUS** output.

* When using servos with a remote battery pack, use **S.BUS** Hub with Cable (2-way/remote battery pack use). Please refer to the instruction manual of **S.BUS** Hub with Cable (2-way/remote battery pack use) for the connection method.

* Turn on the power in transmitter → receiver order. In addition, always check the operation of all the servos before flight.

* Do not insert or remove the servo connector while the receiver power is ON.