

# R7014SB ◆ FASSTest-2.4GHz Bidirectional Communication System / FASST-Multi-ch 2.4GHz S.BUS2 / S.BUS Port and 12 Channels (+DG1,2) for Conventional System Receiver

Thank you for purchasing a Futaba R7014SB FASSTest-2.4GHz compatible receiver. The R7014SB receiver features bi-directional communication with a FASSTest Futaba transmitter using the S.BUS2 port. Using the S.BUS2 port an impressive array of telemetry sensors may be utilized. It also includes both standard PWM output ports and S.BUS output ports. The R7014SB can also be switched the FASST-Multi-ch System.

## ● Applicable systems: Futaba FASSTest-2.4GHz / FASST-Multi-ch system transmitter

### Usage precaution

- Analog servos cannot be used with the R7014SB in the FASSTest 12CH mode.
- When the FASST Multi-ch High-speed Mode is used, analog servos cannot be used at the CH1 ~ 6 outputs for convention systems. However, in other than the FASSTest 12CH mode, analog servos can be used at CH7 ~ 12, DG1 and DG2 at any time.
- Don't connect to Extra Voltage Telemetry Port before turning on a receiver.

### ⚠ WARNING

❶ Changes or modification not especially approved by the party responsible for compliance could void the user's authority to operate the equipment.

❷ The R7014SB receiver should be protected from vibration by foam rubber, Velcro, or similar mounting methods. Protect from moisture.

### Antenna installation precaution

⊖ Do not cut or bundle the receiver antenna wire.

⊖ Do not bend the coaxial cable. It causes damage.

❶ The antennas must be mounted in such a way to assure they are strain relieved.

❶ Keep the antenna as far away from the motor, ESC and other noise sources as you possibly can.

❶ Be sure that the two antennas are placed at 90 degrees to each other.

■ The R7014SB has two antennas. In order to maximize signal reception and promote safe modeling Futaba has adopted a diversity antenna system. This allows the receiver to obtain RF signals on both antennas and fly problem-free.

### Antenna installation for carbon fuselage

❶ You must leave 30mm at the tip of the antenna fully exposed. The exposed antenna should be secured so that it cannot move around or back inside of your aircraft.

### Be careful of connector insertion

⊖ Don't connect an S.BUS servo / gyro to S.BUS2 connector.

⊖ Do not connect the power supply battery to other than the power supply connector.

■ There is the danger of ignition, explosion, or burning.

### Link precaution

⊖ Do not perform the linking procedure while the motor's main power connected or the engine is operating as it may result in serious injury.

❶ When the linking is complete, please cycle the receiver power and ensure the receiver is properly linked to the transmitter.

❶ Please power up your system in this order. Transmitter first, followed by the receiver.

❶ If the R7014SB receiver was previously linked to another transmitter, make sure that transmitter is not operating while linking the receiver to the new transmitter.

### (Antenna installation)

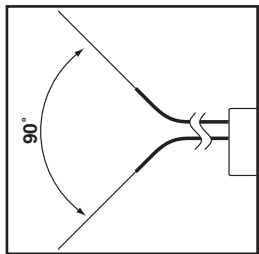

### Connection

The receiver power supply can be connected to any port.

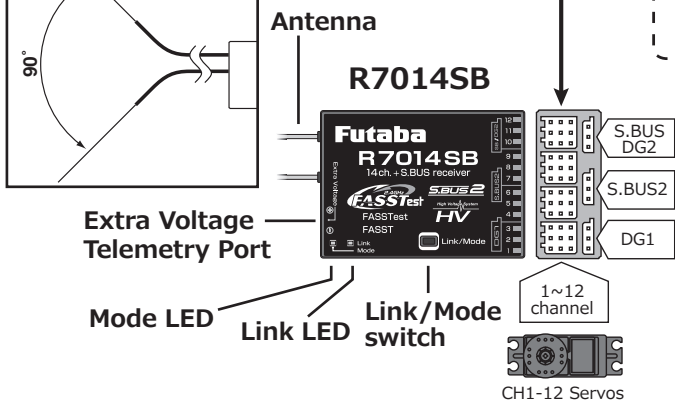

### Connector

The direction of the connectors of the bottom 3 ports is different by 90°.

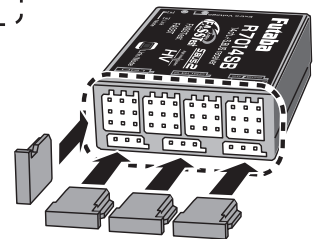

### R7014SB Specifications

FASSTest-2.4GHz system (14CH/12CH mode)

FASST-2.4GHz system (Multi-ch mode)

S.BUS2 and S.BUS port and Linear 12 ch + Digital 2 ch for conventional system receiver

- Dual antenna diversity
- Size: 1.5 x 2 x 0.6 in. (37.0x50.2x15.9mm)
- Weight: 0.7 oz. (20.8g)
- Power requirement: 3.7V to 7.4V (Voltage range: 3.5 to 8.4V)
- Battery F/S Voltage: FASSTest: It sets up with a transmitter FASST: 3.8V \*The Battery F/S voltage is set for 4-cell NiCd/NiMH battery. Battery F/S function doesn't work properly when other type battery is used.
- Extra Voltage port: 0 ~ 70V DC

### LED Indication

System	Mode LED	Status	Link LED
FASSTest	Green Solid	No signal reception	Red Solid
		Receiving signals	Green Solid
		Waiting for link	Start → 2second later → Red Blink (1second)
FASST	Off	No signal reception	Red Solid
		Receiving signals	Green Solid
		Receiving signals but ID is unmatched	Green Blink
		Waiting for link	Red Blink
FASSTest FASST	—	Unrecoverable error (EEPROM, etc.)	Alternate blink

### Compliance Information Statement (for U.S.A.)

This device, complies with part 15 of the FCC Rules. Operation is subject to the following three conditions:

(1) This device may not cause harmful interference, and (2) This device must accept any interference received, including interference that may cause undesired operation.

To assure continued FCC compliance:

1. Any changes or modifications not expressly approved by the grantee of this device could void the user's authority to operate the equipment.
2. This equipment complies with FCC radiation exposure limits set forth for an uncontrolled environment. This equipment should be installed and operated with minimum distance 20cm between the radiator & your body.

The responsible party for the compliance of this device is:

Futaba Service Center  
3002 N Apollo Drive Suite 1, Champaign, IL 61822 U.S.A  
TEL (217)398-8970 or E-mail: support@futaba-rc.com (Support)  
TEL (217)398-0007 or E-mail: futabaservice@hobbico.com (Service)

本產品符合低功率電波輻射性電機管理辦法 第十二條、第十四條等條文規定

1. 經型式認證合格之低功率射頻電機，非經許可，公司、商號或使用者均不得擅自變更頻率、加大功率或變更原設計之特性及功能。
2. 低功率射頻電機之使用不得影響飛航安全及干擾合法通信；經發現有干擾現象時，應立即停用，並改善至無干擾時方得繼續使用。前項合法通信，指依電信法規定作業之無線電通信。低功率射頻電機須忍受合法通信或工業、科學及醫療用電波輻射性電機設備之干擾。

## FASSTest ⇔ FASST (Normal-Hi-speed) Change method

1. Turn on the receiver. (Transmitter OFF)
2. Press and hold the Link/Mode button for at least 5 seconds.
3. When the mode LED begins to blink green/red the button may be released.
4. The mode LED should now be blinking red in one of the patterns described by the chart below. ( Default : FASSTest )
5. Each press of the Mode/Link button advances the receiver to the next mode.
6. When you reach the mode that you wish to operate in, press and hold the Mode/Link button for more than 2 seconds.
7. Once locked into the correct mode the mode LED will change to a solid color.
8. Please cycle the receiver(s) power off and back on again after changing the Channel Mode.

Mode LED Red blink	System
1 time	FASSTest
2 time	FASST Multi-ch Normal mode
3 time	FASST Multi-ch High-speed mode

\*Fixed at neutral if a servo is connected to a port other than a usable transmitter channel.

\*The telemetry and Extra Voltage ports cannot be used with the FASST system.

## S.BUS ⇔ DG2 (SB/DG2 port) Change method

1. Turn on the receiver. (Transmitter OFF)
2. Press and hold the Link/Mode button for at least 15 seconds.
3. When the mode LED begins to blink red the button may be released.
4. The mode LED should now be blinking red in one of the patterns described by the chart below. ( Default : S.BUS )
5. Each press of the Mode/Link button advances the receiver to the next mode.
6. When you reach the mode that you wish to operate in, press and hold the Mode/Link button for more than 2 seconds.
7. Once locked into the correct mode the mode LED will change to a solid color.
8. Please cycle the receiver(s) power off and back on again after changing the Channel Mode.

Mode LED Red blink	System
1 time	S.BUS
2 time	DG2

## FASSTest

### FASSTest

FASSTest is a bidirectional communication system between the R7014SB receiver and FASSTest capable transmitters. Multiple optional telemetry sensors may be connected to the S.BUS2 on the receiver and that data is in turn displayed on the transmitter.

\*Please see your transmitters operation manual to configure transmitter to operate with telemetry sensors.

### Link to the transmitter : FASSTest

- 1 Bring the transmitter and the receiver close to each other, within 20 inches (half meter).
  - 2 Turn on the transmitter. Place the transmitter into the receiver linking mode.
  - 3 Turn on the receiver.
  - 4 The receiver will wait for the linking process to begin for 2 seconds. Following that it will return to the normal operation mode.
  - 5 When the link LED of the receiver changes from blinking red to solid green, linking is complete. (A link waiting state is ended in 1 second.)
- Refer to the transmitters operation manual for complete details on how to place the transmitter into the linking mode.
  - If there are many FASSTest systems turned on in close proximity, your receiver might have difficulty establishing a link to your transmitter. This is a rare occurrence. However, should another FASSTest transmitter/receiver be linking at the same time, your receiver could link to the wrong transmitter. This is very dangerous if you do not notice this situation. In order to avoid the problem, we strongly recommend you to double check whether your receiver is really under control by your transmitter.
  - If the System Type of the transmitter is changed, the receiver will need to be re-linked to the transmitter.

### S.BUS2

S.BUS2 extends S.BUS and supports bidirectional communication. Sensors are connected to the S.BUS2 port.

\*Only S.BUS2 capable devices may be connected to the S.BUS2 port. Standard S.BUS servos and gyros should not be connected to the S.BUS2 port.

### Extra Voltage Telemetry port

It connects with the battery for power, etc.

External voltage input cable (CA-RVIN-700) of an option is used. The voltage of the battery can be displayed with a transmitter.

### When a telemetry adapter (TMA-1) is used : FASSTest only

When using a TMA-1 (sold separately), change the settings by the following method.

The TMA-1 is a device for viewing the telemetry data on a smartphone or tablet.

### R7014SB and TMA-1 linking method

1. Switch the receiver to FASSTest system.
2. Link the transmitter and receiver, and after confirming operation, turn off the power.
3. Turn on the receiver power. (Transmitter power off)
4. Press the Link/Mode switch for at least 10 seconds.
5. When the mode LED begins to blink green the button may be released.
6. The receiver enters the linked with TMA-1 mode, and the LED begins red/green simultaneous rapid blinking.
7. Press the TMA-1 link switch until the LED starts to blink and wait for the TMA-1 to link.
8. When TMA-1 linking is complete, the TMA-1 LED changes from red to green for a moment.
9. When linking is complete, turn on the receiver power and check the operation of all the devices.

## FASST

### FASST

When switched, the R7014SB can use the FASST-Multi-ch mode. When the FASST system is used, the telemetry and Extra Voltage ports cannot be used. The FASST system has a Normal mode and a High-speed mode. However, in the High-speed mode, analog servos cannot be used at CH1 ~ 6.

### Link to the transmitter : FASST

- 1 Bring the transmitter and the receiver close to each other, within 20 inches (half meter).
  - 2 Turn on the transmitter and receiver.
  - 3 Link operation is performed by the Link/Mode switch.
- When using TM-8 module, it's possible to set F/S position (only 3CH).

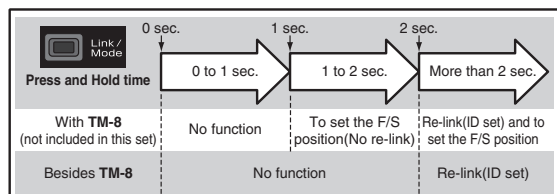

\*Refer to the instruction manual of the transmitter or module used for a description of the linking operation, F/S position setting methods and other details.

### When using Multi prop (MPDX-1)

The MPDX-1 can be used with FASSTest by merely setting the corresponding transmitter. (Refer to the instruction manual of the corresponding transmitter.) When using the MPDX-1 Multi Prop Decoder (sold separately) with the FASST system, change the setting by the following method. Enable the MPDX-1 at channels 11 and 12. (Initial value: OFF) Channels 11 and 12 cannot be used individually for MPDX-

1 output. The MPDX-1 extends 1 channel to 8 channels. However, since the response speed becomes slower and there are functional restrictions, use it at simple switch operation and other applications that require numerous channels.

### Multi prop mode Change method

1. Switch the receiver to the FASST system (Normal or High-speed).
2. Turn on the receiver power. (Transmitter power off)
3. Press the Link/Mode switch for at least 10 seconds.
4. When the mode LED begins to blink green the button may be released.
5. The receiver enters the multi prop mode and the LED of the current mode blinks. (Initial value: OFF)
6. Each time the switch is pressed, the mode changes.
7. When the receiver was switched to the desired mode, press the Link/Mode switch for at least 2 seconds.
8. When the mode LED switches to red/green simultaneous rapid blinking, mode switching is complete. Release the switch.
9. When switching is complete, turn on the power. When the power is turned on, the receiver switches to the new mode.

Mode LED Green blink	Mode
1 time	Multi prop mode OFF
2 time	Multi prop mode ON

IC Warning:

This device complies with Industry Canada license-exempt RSS standard(s). Operation is subject to the following two conditions: (1) this device may not cause interference, and (2) this device must accept any interference, including interference that may cause undesired operation of the device.

This equipment complies with IC radiation exposure limits set forth for an uncontrolled environment. This equipment should be installed and operated with minimum distance 20cm between the radiator and your body.

French: Cet appareil radio est conforme au CNR d'Industrie Canada. L'utilisation de ce dispositif est autorisée seulement aux deux conditions suivantes : (1) il ne doit pas produire de brouillage, et (2) l'utilisateur du dispositif doit être prêt à accepter tout brouillage radioélectrique reçu, même si ce brouillage est susceptible de compromettre le fonctionnement du dispositif. Cet équipement est conforme aux limites d'exposition aux rayonnements IC établies pour un environnement non contrôlé. Cet équipement doit être installé et utilisé avec un minimum de 20 cm de distance entre la source de rayonnement et votre corps.