

---

## S.BUS/S.BUS2 device setting

S.BUS/S.BUS2 servos or a telemetry sensor can be connected directly to the T14SG. Channel setting and other data can be entered for the S.BUS/S.BUS2 servos or sensors.

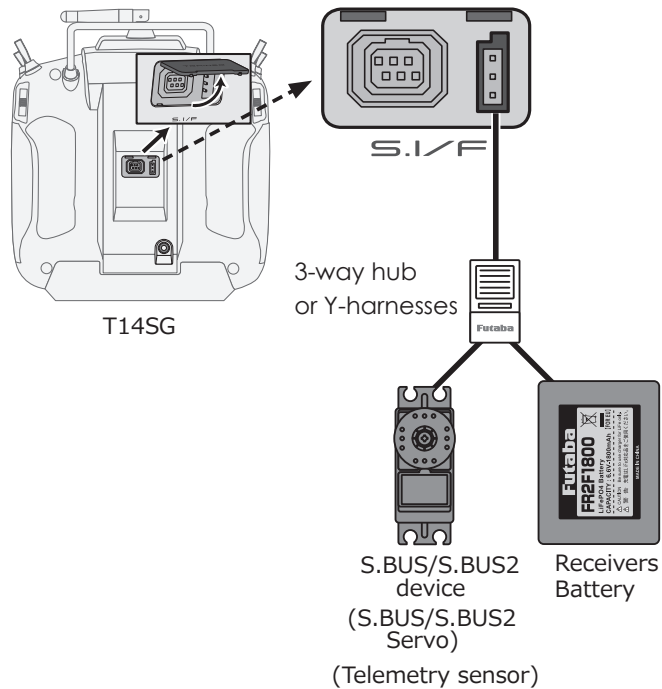

1. Connect the S.BUS device and battery you want to set with a 3-way hub or Y-harnesses as shown in the figure.
2. Turn on the transmitter power.
3. Call the setup screen.  
Servo: System Menu → S.BUS Servo  
Sensor: Linkage Menu → Sensor
4. Perform setting in accordance with each screen.
5. This sets the channel and other data for each S.BUS servo, or telemetry device to be used with the S.BUS device or receiver.

## Telemetry System

The R7008SB receiver features bi-directional communication with a FASSTest Futaba transmitter using the S.BUS2 port. Using the S.BUS2 port an impressive array of telemetry sensors may be utilized. It also includes both standard PWM output ports and S.BUS output ports.

- \* Telemetry is available only in the FASSTest 14CH mode. (12CH mode displays only Receiver battery voltage and Extra battery voltage.)
- \* The telemetry function requires the corresponding receiver (R7008SB).
- \* The T14SG will enter and keep the ID number of the R7008SB that it is linked to.

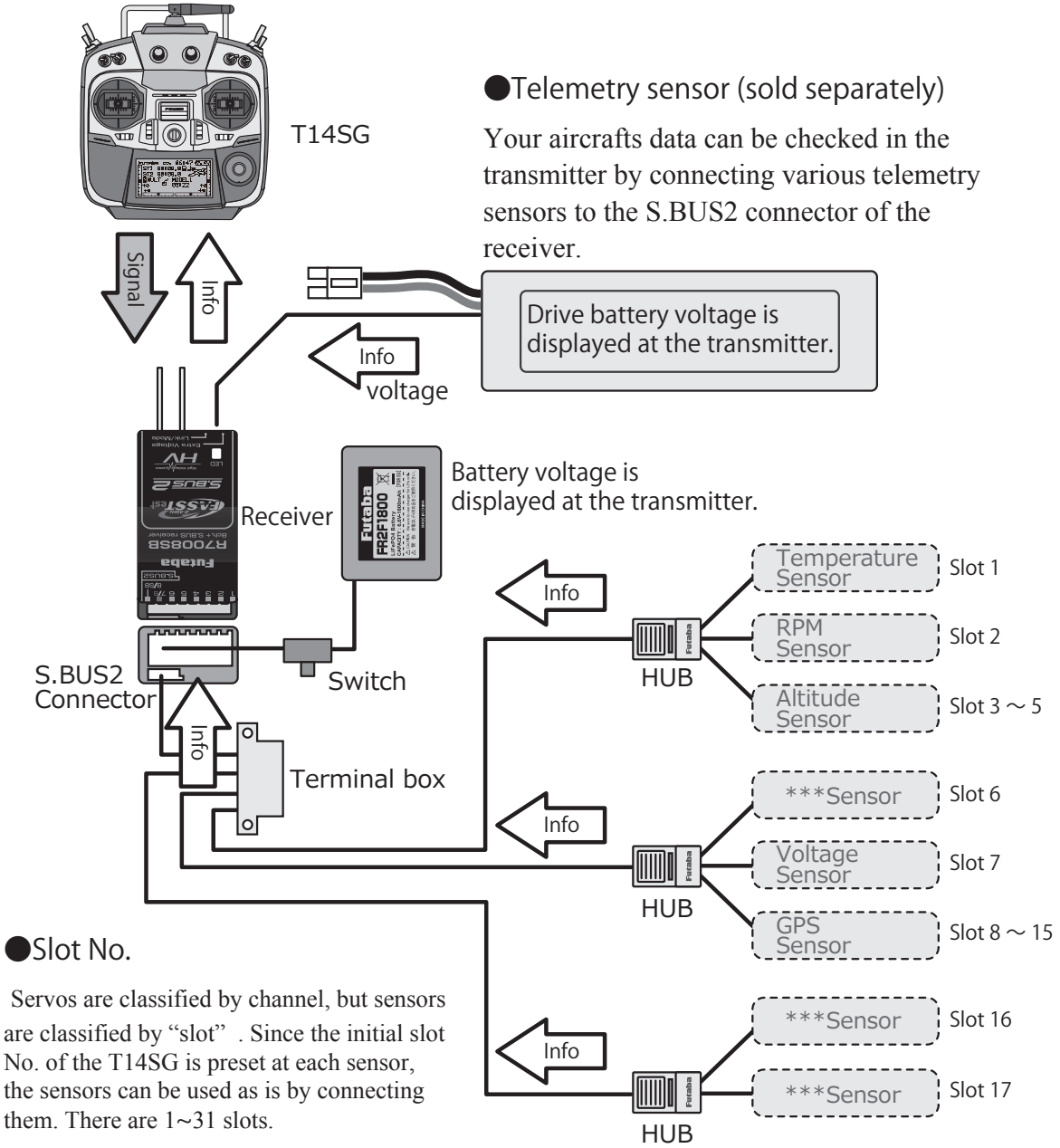

## BASIC OPERATION

### Battery Charging

Before charging batteries, read the "Cautions for handling battery and battery charger" in the section "NiMH/NiCd Battery Safety and Handling Instructions".

#### How to charge the NiMH battery HT5F1800B for the transmitter

##### **⚠ Danger**

⊘ The NiMH battery HT5F1800B is only for your T14SG. Do not use this battery for other equipment.

❗ Be sure to use the attached special charger to charge the battery.

\*If you take the NiMH battery HT5F1800B out of the transmitter, you can use the optional quick charger CR-2000 corresponding to NiMH battery.

\*Battery charging will not automatically stop. Remove the battery and transmitter from the charger and remove the charger from the wall socket.

\*It is recommended to reactivate the battery by cycling several times if the battery has not been used for a long period.

\*In the case of NiMH/NiCd batteries, you may find poor performance of the battery if you have used the battery only for a short period or if you repeat charging while the battery is not fully discharged. It is suggested to discharge the battery to the recommended level after use. It is also recommended to charge the battery just before use.

[Method of charging battery]

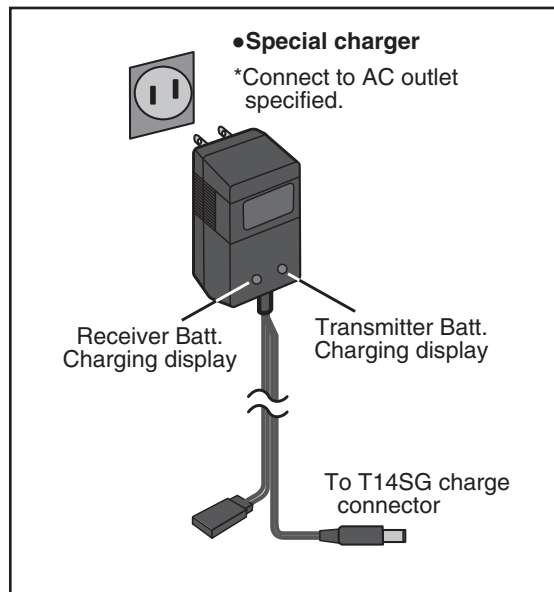

1. Connect the special charger to the wall socket (AC outlet).
2. Connect the connectors to the T14SG charging jack.

\*Confirm that the charging indicator, LED lamp, is on.

\*Turn off the transmitter while charging the battery.

3. Remove the battery after 15 hours.

---

## How to turn transmitter power ON/OFF

When turning on the power, the T14SG transmitter will begin emitting RF automatically after it confirms the surrounding RF conditions.

The T14SG transmitter also offers the ability to auto shut-down.

### When turning on the power of the transmitter

THR Stick Slow

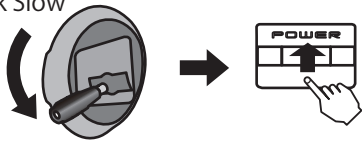

1. Turn on the power switch of the transmitter.

\*The message "CHECK RF CONDITION" is displayed for a moment. At the same time the left LED monitor blinks.

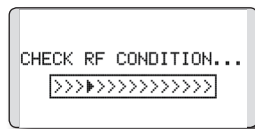

2. Then, you will see the home screen and the transmitter begins to emit radio waves.

\*The left and right LED monitors will change to solid red.

### How to stop the transmitter

1. Turn off the power switch of the transmitter.

\*The transmitter shuts down at once.

### Low battery alarm and auto shut-down

When the battery voltage reaches 5.2V, an audible alarm will sound. Land your aircraft immediately.

When the battery voltage reaches 3.9V, the transmitter will be turned off automatically.

\*If you do not operate the transmitter (or move a stick, knob, switch or digital trim) for 30 minutes, the message "PLEASE TURN OFF POWER SWITCH" is displayed and an audible alarm will sound.

### Warning display at power ON (Airplane/Helicopter)

When the throttle stick during Power On is at the high side (or over 1/3 stick) a warning will be displayed.

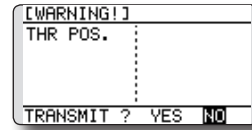

\*below 1/3 stick, the warning display goes off.

---

## Registration of the user's name

If so desired, the T14SG transmitter can indicate the owner's name.

### User's name setup screen

1. Turn on the power of the transmitter.

\*The home screen appears.

2. Lightly touch the SYS button twice rapidly and the System menu appears.

3. Select [USER NAME] in the System menu and touch the RTN button.

\*The user name set up screen appears.

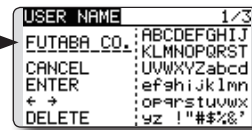

Input Box

\*Current user name is displayed.

### Changing the user name

1. Change the user name as described below:  
[Moving cursor in input box]

Select [←] or [→], and touch the RTN button.

[Deleting a character]

When [DELETE] is selected and the RTN button is touched, the character immediately after the cursor is deleted.

[Adding a character]

When a character is selected from the character list and the RTN button is touched, that character is added at the position immediately after the cursor.

\*A name of up to 10 characters long can be entered as the user name. (A space is also counted as one character.)

2. At the end of input, select [ENTER] and touch the RTN button. (To terminate input and return to the original state, select [CANCEL] and touch the RTN button.)

## Home screen

Use the touch sensor to select the following display area to call each setting screen, and touch the RTN button. The setting screen appears.

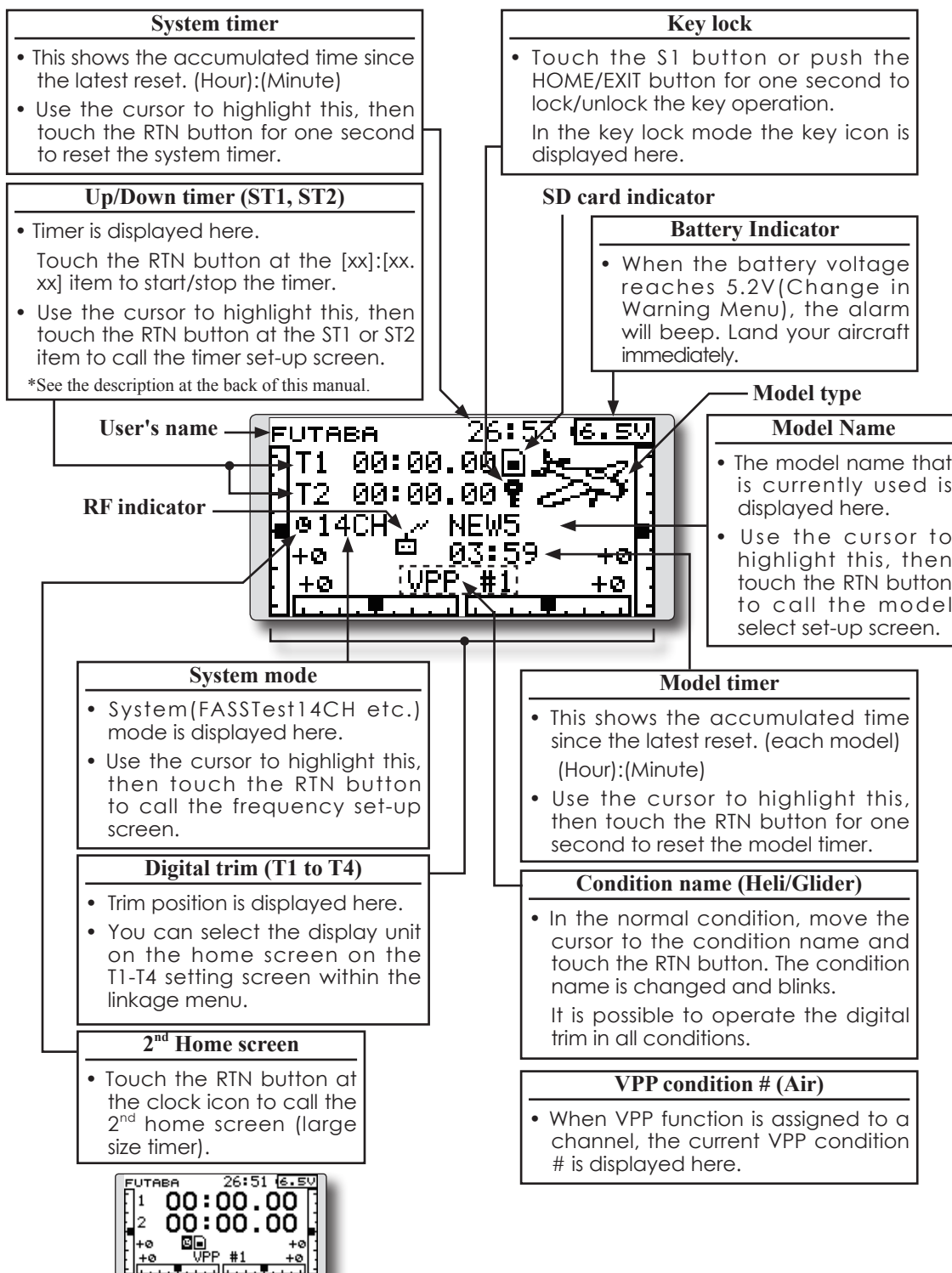

## User Menu

A user menu which allows the user to customize and display frequently used functions has been added.

1. When the "U.MENU" button is pushed for two seconds, the user menu appears.

\*Return to the home screen by touching the EXIT button while the user menu is being displayed.

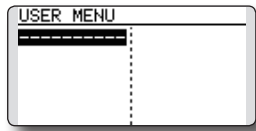

2. When the cursor highlights the dotted line, "-----" and the RTN button is touched, the menu selection screen appears.

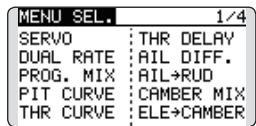

3. When the cursor is moved to the setting that you to set to the user menu and the RTN button is touched, that setting screen is added to the user menu.
4. The registered setting screen can be called by moving the cursor to it and touching the RTN button.

\*When you want to delete an added screen from the user menu, highlight item you wish to delete, press and hold the RTN button for one second.

## Warning

- ! Be sure to confirm the model name before flying your aircraft.
- ! Check the battery voltage as often as possible and try to charge the battery earlier. If the battery alarm makes a sound, land your aircraft immediately.

## Link procedure (T14SG/R7008SB)

Each transmitter has an individually assigned, unique ID code. In order to start operation, the receiver must be linked with the ID code of the transmitter with which it is being paired. Once the link is made, the ID code is stored in the receiver and no further linking is necessary unless the receiver is to be used with another transmitter. When you purchase additional R7008SB receivers, this procedure is necessary; otherwise the receiver will not work.

### Link procedure

1. Place the transmitter and the receiver close to each other within half (0.5m) meter.

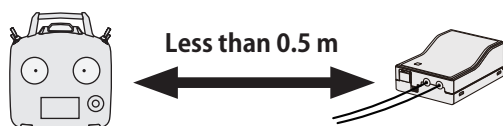

2. Turn on the transmitter.
3. Select [SYSTEM] at the Linkage menu and access the setup screen shown below by touching the RTN button.

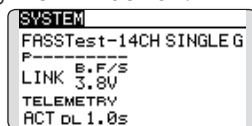

:You can do this through the LINKAGE Menu and scroll to System and press RTN.

4. When you use two receivers on one model, you must change from [SINGLE] to [DUAL].

\*Only two receivers can be used. In "DUAL", two setting items come out. Input, respectively.

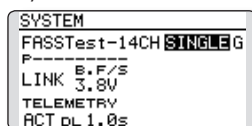

ID of a Primary receiver displays.

ID of a Secondary receiver displays.

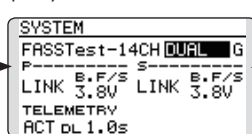

In DUAL, a primary receiver is link previously. Next, a secondary receiver is link.

5. "F" will be chosen if it is used in France. others "G" general.

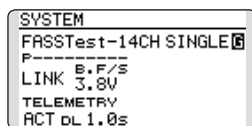

6. When changing battery fail-safe voltage from the initial value 3.8V, voltage is changed here.

\* Only in FASSTest Mode.

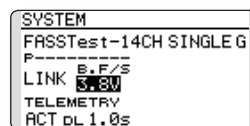

7. [LINK] is chosen by scrolling and the RTN button is pushed. The transmitter will emit a chime as it starts the linking process.

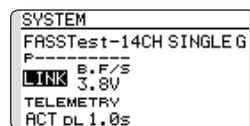

8. When the transmitter starts to chime, power on the receiver. The receiver should link to the transmitter within about 1 second.

### In "Link" Mode



9. If linking fails, an error message is displayed. Bring the transmitter closer to the receiver and repeat the procedure above from Step 2.

10. ACT will be chosen if telemetry is used. It is INH when not using it.

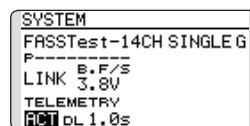

11. When a telemetry function is enabled, the receiving interval (down-link interval) of sensor data can be changed. If a DL interval is increased, the response of the sensor data display becomes slower, but stick response will improve.

Initial value: 1.0s

Adjustment range: 0.1s~2.0s

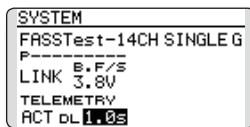

\*If there are many FASSTest systems turned on around your receiver, it might not link to your transmitter. In this case, even if the receiver's LED stays solid green, unfortunately the receiver might have established a link to one of other transmitters. This is very dangerous if you do not notice this situation. In order to avoid the problem, we strongly recommend you to doublecheck whether your receiver is really under control by your transmitter by giving the stick input and then checking the servo response.

\*Do not perform the linking operation when the drive motor is connected or the engine is running.

\* When you use two receivers, please be sure to setup a "primary" and "secondary" in the "dual" mode.

\*Since two sets of receivers cannot be individually recognized without using a "primary" and "secondary" setup, it is impossible to receive telemetry data correctly.

\* You must link one receiver at a time. If both power supplies to the receivers are switched on simultaneously, data is received incorrectly by the transmitter.

\* If a dual receiver function is used, in order to receive sensor information correctly by both sets, telemetry data will be slower compared to a single receiver setup.

\* You cannot link three receivers.

\* Link is required when a system type is changed.

\* Linking is required whenever a new model is made.

\* Link is required when a system type is changed.

### Warning

 After the linking is done, please cycle receiver power and check that the receiver to be linked is really under the control of the transmitter.

 Do not perform the linking procedure with motor's main wire connected or with the engine operating as it may result in serious injury.



---

## Range Testing Your R/C System

It is extremely important to range check your models prior to each flying session. This enables you to ensure that everything is functioning as it should and to obtain maximum enjoyment from your time flying. The T14SG transmitter incorporates a system that reduces its power output and allows you to perform such a range check.

### Range check mode

We have installed a special "Range check mode" for doing a ground range check. To access the "Range check mode" touch and hold the RTN button while turning on the transmitter. Doing so will bring up POWER MODE menu.

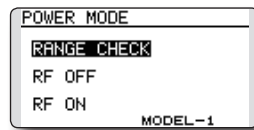

↑ The present model

To activate the "Range check mode" touch the RTN button and the range check mode screen will appear.

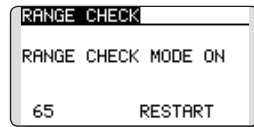

During this mode, the RF power output is reduced so the range test can be performed. In addition, when this mode is activated the right LED on the front of the transmitter starts blinking and the transmitter gives users a warning with a beeping sound every 3 seconds.

The "Range check mode" continues for 90 seconds and after that the power will return to the normal level. To exit the "Range check mode" before the 90 seconds, select the "RANGE CHECK" at the top of the screen and touch the RTN button again. This mode is available one time only so if you need to re-use this function the transmitter power must be cycled. NEVER start flying when the "Range check mode" is active.

Should you require additional time to perform a range check, highlight Restart before your time expires and press the RTN button one time.

### Range check procedure

1. With the "Range check mode" on, walk away from the model while simultaneously operating the controls. Have an assistant stand by the model to confirm that all controls are completely and correctly operational. You should be able to walk approximately 30-50 paces from the model without losing control.
2. If everything operates correctly, return to the model. Set the transmitter in a safe, yet accessible, location so it will be within reach after starting the engine or motor. Be certain the throttle stick is in the low throttle position, then start the engine or motor. Perform another range check with your assistant holding the aircraft with the engine running at various speeds. If the servos jitter or move inadvertently, there may be a problem. We would strongly suggest you do not fly until the source of the difficulty has been determined. Look for loose servo connections or binding pushrods. Also, be certain that the battery has been fully charged.

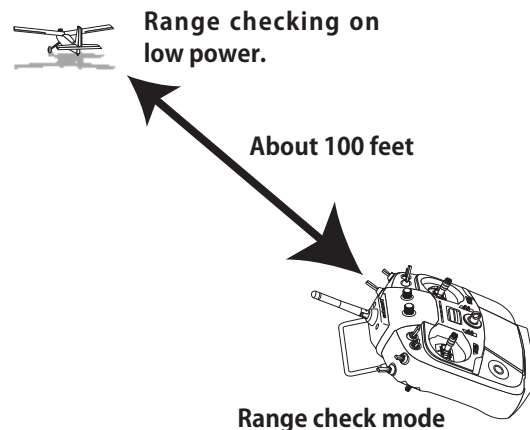

**Warning**

! Do not fly in the range check mode.

\*Since the range of the radio waves is short, if the model is too far from the transmitter, control will be lost and the model will crash.

# RECEIVER AND SERVO INSTALLATION

## Receiver and servos connection

Connect the receiver and servos in accordance with the connection diagram shown below. Always read the section [Before using]. When mounting the receiver and servos to the fuselage, connect the necessary points in accordance with the model's instruction manual.

### Receiver and servos connection diagram

Always connect the necessary number of servos.

The receiver channel assignment depends on the model type. See the Servo connection by model type tables.

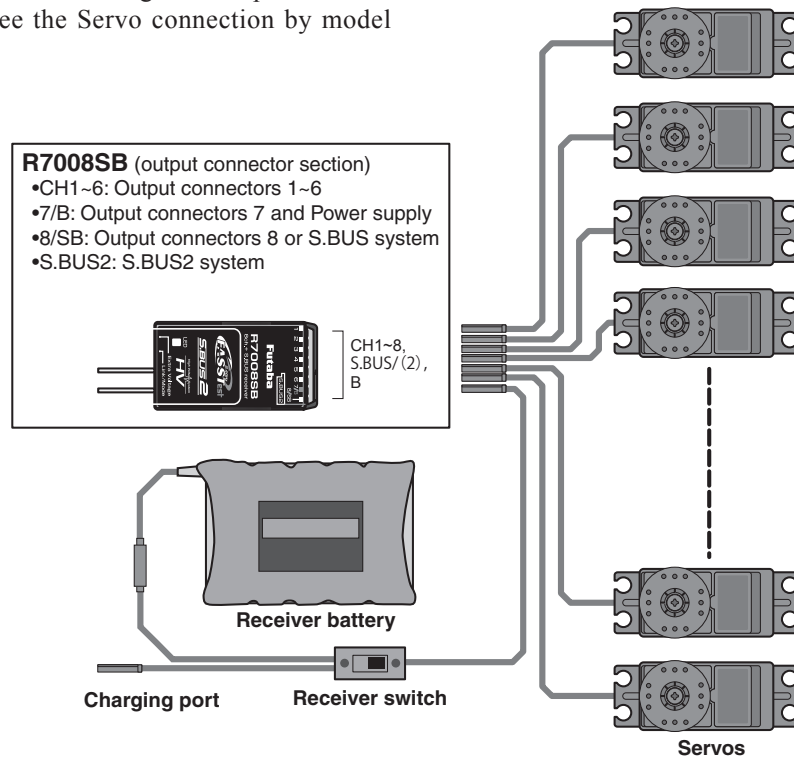

## Servo connection by model type

The T14SG transmitter channels are automatically assigned for optimal combination according to the type selected with the Model Type function of the Linkage Menu. The channel assignment (initial setting) for each model type is shown below. Connect the receiver and servos to match the type used.

\*The set channels can be checked at the Function screen of the Linkage Menu. The channel assignments can also be changed. For more information, read the description of the Function menu.

### Airplane/glider

#### Normal wing and V-tail

R X	1Aileron		2Aileron		2Aileron+1FLAP		2Aileron+2FLAP		2Aileron+4FLAP		4Aileron+2FLAP		The output CH of each system
	Airplane	Glider	Airplane	Glider	Airplane	Glider	Airplane	Glider	Airplane	Glider	Airplane	Glider	
1	Aileron	Aileron	Aileron	Aileron	Aileron	Aileron	Aileron	Aileron	Aileron	Aileron	Aileron	Aileron	FASTest14CH FASTest12CH S-FHSS FAST7CH
2	Elevator	Elevator	Elevator	Elevator	Elevator	Elevator	Elevator	Elevator	Elevator	Elevator	Elevator	Elevator	
3	Throttle	Motor	Throttle	Motor	Throttle	Motor	Throttle	Motor	Rudder	Rudder	Rudder	Rudder	
4	Rudder	Rudder	Rudder	Rudder	Rudder	Rudder	Rudder	Rudder	Aileron2	Aileron2	Aileron2	Aileron2	
5	Gear	AUX7	Gear	AUX7	Gear	AUX6	Gear	AUX5	Flap	Flap	Aileron3	Aileron3	
6	VPP	AUX6	Aileron2	Aileron2	Flap	Flap	Aileron2	Aileron2	Flap2	Flap2	Aileron4	Aileron4	
7	AUX5	AUX5	VPP	AUX6	Aileron2	Aileron2	Flap	Flap	Flap3	Flap3	Flap	Flap	
8	AUX4	AUX4	AUX5	AUX5	VPP	AUX5	Flap2	Flap2	Flap4	Flap4	Flap2	Flap2	
9	AUX1	AUX1	Camber	Camber	Camber	Camber	Camber	Camber	Camber	Camber	Camber	Camber	
10	AUX1	AUX1	AUX1	Butterfly	AUX1	Butterfly	VPP	Butterfly	Gear	Butterfly	Gear	Butterfly	
11	AUX1	AUX1	AUX1	AUX1	AUX1	AUX1	AUX1	AUX1	Throttle	Motor	Throttle	Motor	
12	AUX1	AUX1	AUX1	AUX1	AUX1	AUX1	AUX1	AUX1	VPP	AUX1	VPP	AUX1	
DG1	SW	SW	SW	SW	SW	SW	SW	SW	SW	SW	SW	SW	
DG2	SW	SW	SW	SW	SW	SW	SW	SW	SW	SW	SW	SW	

#### Ailvator (Dual Elevator)

R X	1Aileron		2Aileron		2Aileron+1FLAP		2Aileron+2FLAP		2Aileron+4FLAP		4Aileron+2FLAP		The output CH of each system
	Airplane	Glider	Airplane	Glider	Airplane	Glider	Airplane	Glider	Airplane	Glider	Airplane	Glider	
1	Aileron	Aileron	Aileron	Aileron	Aileron	Aileron	Aileron	Aileron	Aileron	Aileron	Aileron	Aileron	FASTest14CH FASTest12CH S-FHSS FAST7CH
2	Elevator	Elevator	Elevator	Elevator	Elevator	Elevator	Elevator	Elevator	Elevator	Elevator	Elevator	Elevator	
3	Throttle	Motor	Throttle	Motor	Throttle	Motor	Throttle	Motor	Rudder	Rudder	Rudder	Rudder	
4	Rudder	Rudder	Rudder	Rudder	Rudder	Rudder	Rudder	Rudder	Aileron2	Aileron2	Aileron2	Aileron2	
5	Gear	AUX7	Gear	AUX7	Gear	AUX6	Elevator2	Elevator2	Flap	Flap	Aileron3	Aileron3	
6	VPP	AUX6	Aileron2	Aileron2	Flap	Flap	Aileron2	Aileron2	Flap2	Flap2	Aileron4	Aileron4	
7	Elevator2	Elevator2	Elevator2	Elevator2	Aileron2	Aileron2	Flap	Flap	Flap3	Flap3	Flap	Flap	
8	AUX4	AUX4	VPP	AUX5	Elevator2	Elevator2	Flap2	Flap2	Flap4	Flap4	Flap2	Flap2	
9	AUX1	AUX1	Camber	Camber	Camber	Camber	Camber	Camber	Camber	Camber	Camber	Camber	
10	AUX1	AUX1	AUX1	Butterfly	VPP	Butterfly	Gear	Butterfly	Gear	Butterfly	Gear	Butterfly	
11	AUX1	AUX1	AUX1	AUX1	AUX1	AUX1	VPP	AUX1	Throttle	Motor	Throttle	Motor	
12	AUX1	AUX1	AUX1	AUX1	AUX1	AUX1	AUX1	AUX1	Elevator2	Elevator2	Elevator2	Elevator2	
DG1	SW	SW	SW	SW	SW	SW	SW	SW	SW	SW	SW	SW	
DG2	SW	SW	SW	SW	SW	SW	SW	SW	SW	SW	SW	SW	

## Airplane/glider

### Flying wing, Delta wing

R X CH	2Aileron		2Aileron+1FLAP		2Aileron+2FLAP		2Aileron+4FLAP		4Aileron+2FLAP		The output CH of each system
	Airplane	Glider	Airplane	Glider	Airplane	Glider	Airplane	Glider	Airplane	Glider	
1	Aileron	Aileron	Aileron	Aileron	Aileron	Aileron	Aileron	Aileron	Aileron	Aileron	FASSTest 14CH FASSTest 12CH S-FHSS FASST7CH FASST MULT
2	VPP	AUX4	VPP	AUX4	VPP	AUX4	Aileron2	Aileron2	Aileron2	Aileron2	
3	Throttle	Motor	Throttle	Motor	Throttle	Motor	Rudder	Rudder	Aileron3	Aileron3	
4	Rudder	Rudder	Rudder	Rudder	Rudder	Rudder	VPP	AUX4	Aileron4	Aileron4	
5	Gear	AUX7	Gear	AUX6	Gear	AUX6	Flap	Flap	Rudder	Rudder	
6	Aileron2	Aileron2	Flap	Flap	Flap	Flap	Flap2	Flap2	VPP	AUX4	
7	AUX6	AUX6	Aileron2	Aileron2	Aileron2	Aileron2	Flap3	Flap3	Flap	Flap	
8	AUX5	AUX5	AUX5	AUX5	Flap2	Flap2	Flap4	Flap4	Flap2	Flap2	
9	Elevator	Elevator	Elevator	Elevator	Elevator	Elevator	Elevator	Elevator	Elevator	Elevator	
10	Camber	Camber	Camber	Camber	Camber	Camber	Camber	Camber	Camber	Camber	
11	AUX1	AUX1	AUX1	Butterfly	AUX1	Butterfly	Gear	Butterfly	Gear	Butterfly	
12	AUX1	AUX1	AUX1	AUX1	AUX1	AUX1	Throttle	Motor	Throttle	Motor	
DG1	SW	SW	SW	SW	SW	SW	SW	SW	SW	SW	
DG2	SW	SW	SW	SW	SW	SW	SW	SW	SW	SW	

### Flying wing, Delta wing (Winglet 2 Rudder)

R X CH	2Aileron		2Aileron+1FLAP		2Aileron+2FLAP		2Aileron+4FLAP		4Aileron+2FLAP		The output CH of each system
	Airplane	Glider	Airplane	Glider	Airplane	Glider	Airplane	Glider	Airplane	Glider	
1	Aileron	Aileron	Aileron	Aileron	Aileron	Aileron	Aileron	Aileron	Aileron	Aileron	FASSTest 14CH FASSTest 12CH S-FHSS FASST7CH FASST MULT
2	Rudder2	Rudder2	Rudder2	Rudder2	Rudder2	Rudder2	Aileron2	Aileron2	Aileron2	Aileron2	
3	Throttle	Motor	Throttle	Motor	Throttle	Motor	Rudder	Rudder	Aileron3	Aileron3	
4	Rudder	Rudder	Rudder	Rudder	Rudder	Rudder	Rudder2	Rudder2	Aileron4	Aileron4	
5	Gear	AUX7	Gear	AUX6	Gear	AUX6	Flap	Flap	Rudder	Rudder	
6	Aileron2	Aileron2	Flap	Flap	Flap	Flap	Flap2	Flap2	Rudder2	Rudder2	
7	VPP	AUX6	Aileron2	Aileron2	Aileron2	Aileron2	Flap3	Flap3	Flap	Flap	
8	AUX5	AUX5	VPP	AUX5	Flap2	Flap2	Flap4	Flap4	Flap2	Flap2	
9	Elevator	Elevator	Elevator	Elevator	Elevator	Elevator	Elevator	Elevator	Elevator	Elevator	
10	Camber	Camber	Camber	Camber	Camber	Camber	Camber	Camber	Camber	Camber	
11	AUX1	AUX1	AUX1	Butterfly	VPP	Butterfly	Gear	Butterfly	Gear	Butterfly	
12	AUX1	AUX1	AUX1	AUX1	AUX1	AUX1	Throttle	Motor	Throttle	Motor	
DG1	SW	SW	SW	SW	SW	SW	SW	SW	SW	SW	
DG2	SW	SW	SW	SW	SW	SW	SW	SW	SW	SW	

\* Output channels differ by each system of a table. When using a system with few channels, there is a wing type which cannot be used. It cannot be used when there is a function required out of the range of the arrow of a figure.

## Helicopter

### ● FASSTest14CH/FASST MULTI/FASST 7CH/S-FHSS

CH	All Other	H-4, H4X Swash
1	Aileron	Aileron
2	Elevator	Elevator
3	Throttle	Throttle
4	Rudder	Rudder
5	Gyro/RUD	Gyro/RUD
6	Pitch	Pitch
7	Governor	Governor
8	Needle	Elevator2
9	Gyro2/AIL	Gyro2/AIL
10	Gyro3/ELE	Gyro3/ELE
11	AUX1	AUX1
12	AUX1	AUX1
DG1	SW	SW
DG2	SW	SW

The output CH of each system  
 FASSTest 14CH S-FHSS FASST MULTI  
 FASST 7CH

### ● FASSTest12CH

CH	All Other	H-4, H4X Swash
1	Aileron	Aileron
2	Elevator	Elevator
3	Throttle	Throttle
4	Rudder	Elevator2
5	Pitch	Pitch
6	Gyro/RUD	Gyro/RUD
7	Governor	Governor
8	Governor 2	Rudder
9	Gyro2/AIL	Gyro2/AIL
10	Gyro3/ELE	Gyro3/ELE
DG1	SW	SW
DG2	SW	SW

The output CH of each system  
 FASSTest 12CH

- Since the ch8 doesn't work on the 7-ch mode, please assign the elevator2 (H-4, H4X) or the needle (all other) to 7 channel if the governor is not used.

# MODEL BASIC SETTING PROCEDURE

## Airplane/glider basic setting procedure

### 1. Model addition and selection

Initially, the T14SG assigns the first model to model-01 in the transmitter. The Model Select function of the Linkage Menu is used to add models and to select amongst models which are already set.

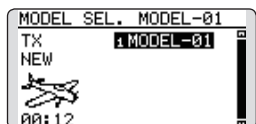

The T14SG is capable of storing data for up to 30 models in its internal memory. Additional model data can also be saved to an optional SD card.

The currently selected model name is displayed in the center of the home screen. Before flying and before changing any settings, always confirm the model name.

When a new model is added, the Model type select screen and System mode setup screen automatically appear. Please be aware that the transmitter will stop transmitting temporarily when you change the model.

When a new model is added, you will need to re-link the receiver.

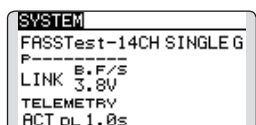
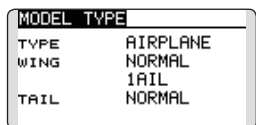

### 2. Model type selection

Select the model type matched to the aircraft with the Model Type select function of the Linkage Menu. For an airplane, select the model type from among the 2 types: airplane and glider. And then select the wing type and the tail type matched to the aircraft.

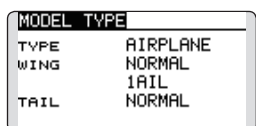

### 3. Fuselage linkage

Connect the ailerons, elevators, throttle, rudder, etc. in accordance with the model's instruction manual. For a description of the connection method, see the Receiver and Servos Connection.

**Note that even for the same "airplane model", when the wing type and tail type are different, the channel assignment may be different. (The channel assigned to each function can be checked at the Function menu of the Linkage Menu.)**

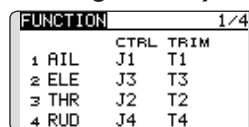

- If the direction of the servo is incorrect, adjust the direction with the Reverse function of the Linkage Menu.

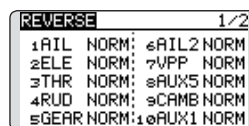

- Adjust the neutral position and control surface angle with the linkage, and fine tune them with the Sub-Trim and End Point functions (angle adjustment). To protect the linkage, a limit position can also be set with the End Point function. The End Point function can adjust the amount of up/down and left/right movement and limit of each channel.

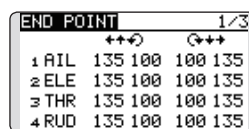
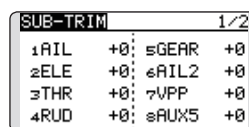

### 4. Throttle cut setting (Airplane)

Throttle cut can be performed with one touch by a switch without changing the throttle trim position.

Set throttle cut with the Throttle Cut function of the Linkage Menu. After activating the throttle cut function and selecting the switch, adjust the throttle position so that the carburetor becomes fully closed. For safety, the throttle cut function operates the

throttle stick in the 1/3 or less (slow side) position.

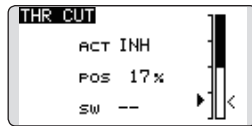

### 5. Idle down setting (Airplane)

The idling speed can be lowered with one touch by a switch without changing the throttle trim position. Perform this setting with the Idle Down function of the Linkage Menu. After activating the Idle Down function and selecting the switch, adjust the idle down speed. For safety, the idle down function acts only when the throttle stick is in the lowest part of its throw.

\*While the Throttle Cut function is in operation, the Idle Down function does not work.

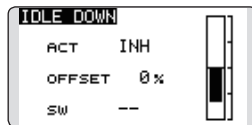

### 6. D/R function

D/R function is used to adjust the throw and operation curve of the stick functions (aileron, elevator, rudder and throttle) for each switch position (airplane) or each flight condition (glider). This is normally used after the modeler has defined the maximum throw directions in the End Point settings.

(Airplane)

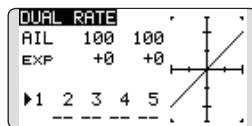

(Glider)

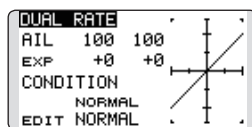

### 7. Airbrake (Airplane)

This function is used when an airbrake is necessary when taking off or diving, etc. Please note: this menu item is only available under certain wing configurations. For example, it will not appear if a single aileron wing type has been selected.

The pre-set elevator and flap offset amount can be activated by a switch.

The offset amount of the aileron, elevator, and flap servos can be adjusted as needed. Also the speed of the aileron, elevator, and flap servos can be adjusted. You can also set the Auto Mode, which will link Airbrake to a stick, switch, or dial. A separate stick switch or dial can also be set as the ON/OFF switch.

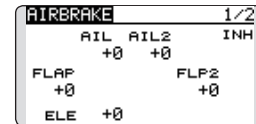

### 8. Addition of flight conditions (Glider)

The Condition Select function automatically allocates the normal condition (NORMAL) for each model. NORMAL is the default condition and is the only one active when a new model type is defined.

If you want to add flight conditions, please refer to a description of the CONDITION function.

CONDITION	NORMAL	1/3
NORMAL	PRIORITY	
START	--	↓
SPEED	--	↑ ↓
DISTANCE	--	↑ ↓
LANDING	--	↑

\*The NORMAL is always on, and remains on until other conditions are activated by switches, stick positions, etc. Please refer to the section entitled Switch Selection Method for additional information on how to do so.

\*It is possible to customize the activation of the flight conditions.

\*The Condition Delay can be programmed for each channel. The Condition Delay is used to change the servo throw smoothly when switching conditions.

## Helicopter basic setting procedure

This section outlines examples of use of the helicopter functions of the T14SG. Adjust the actual values, etc. to match the fuselage used.

### 1. Model addition and selection

Initially, the T14SG assigns the first model to model-01 in the transmitter. To add new models or to select a model already programmed, use the Model Select function of the Linkage Menu.



This is convenient when selecting a model after entering the model's names in advance. The T14SG is capable of storing up to 30 models in the transmitter's internal memory. Additional models can also be stored in an optional SD card.

The currently selected model is displayed in the middle of the screen. Before flying and before changing any settings, always confirm the model name.

When a new model is added, the Model Type select screen and system mode setup screen automatically appear. Change, or check that they match the swash type and receiver type of the model used.

When a new model is added, you will need to re-link the receiver.

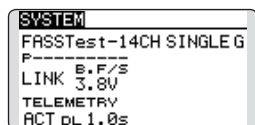
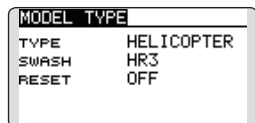

### 2. Model type and swash type selection

If a different model type is already selected, select helicopter with the Model Type function of the Linkage Menu, and then select the swash type matched to the helicopter.

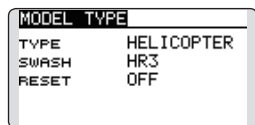

\*The Model Type function automatically selects the appropriate output channels, control functions, and mixing

functions for the chosen model type. Six swash types are available for helicopters.

\*For a description of the swash type selection, refer to the MODEL TYPE function.

### 3. Flight condition addition

The transmitter offers up to five flight conditions per model.

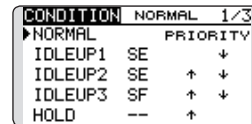

The Condition Select function automatically allocates five conditions for helicopters.

(Initial setting)

- NORMAL
- IDLE UP1 (SW-E)
- IDLE UP2 (SW-E)
- IDLE UP3 (SW-F)
- HOLD (Hold switch is not assigned initially)

**Note:** Since you may accidentally activate a condition that not previously setup during flight which could cause a crash, we suggest deleting conditions that are not used.

\*For a description of the condition deletion, refer to the Condition Select function.

The NORMAL condition is always on, and remains on until other conditions are activated by switches.

The priority is throttle hold/idle up 3/idle up 2/idle up 1/normal. Throttle hold has the highest priority.

The Condition Delay can be programmed for each channel and condition. The Condition Delay is used to change the servo throw smoothly when switching conditions.

#### (General flight condition setting example)

- Normal: (Use initial setting conditions/operate when switch OFF)  
Use from engine starting to hovering.
- Idle up 1: (Operate at SW-E center)  
Use in stall turn, loop, and other maneuvers.
- Idle up 2: (Operate at SW-E forward side)  
Use in rolls.
- Throttle hold: (Operate at SW-G forward side)  
Use in auto rotation.



#### 4. Servo Connection

Connect the throttle rudder, aileron, elevator, pitch, and other servos in accordance with the kit instruction manual. For a description of the connection method, see "Receiver and Servos Connection".

**Note: The channel assigned to each function can be checked at the Function menu of the Linkage Menu.**

FUNCTION	NORMAL	1/4
	CTRL	TRIM
1 AIL	J1	T1 SEPAR
2 ELE	J3	T3 SEPAR
3 THR	J2	T2 SEPAR
4 RUD	J4	T4 SEPAR

- If the direction of operation of the servo is incorrect, use the Reverse function of the Linkage Menu. Also use the swash AFR function in other than the H-1 mode.

THR CURVE	NORMAL	1/3
EDITNORMAL	COPY	
>5	100.0 (100)	
>4	75.0 75.0	
>3	50.0 50.0	
>2	25.0 25.0	
>1	0.0 (0)	

SWASH	1/5
NEUTRAL	AFR
Pos 50%	AIL +50%
	ELE +50%
	PIT +50%

- Adjust the direction of operation of the gyro. (Gyro side function)
- Connect the throttle linkage so that the carburetor can fully close at full trim throttle cut.
- Adjust the neutral position at the linkage side and fine tune with the Sub-Trim function and End Point function. To protect the linkage, a limit position can also be set with the End Point function.

SUB-TRIM	1/2
1AIL	+0; 5GYRO +0
2ELE	+0; 6PIT +0
3THR	+0; 7GOV +0
4RUD	+0; 8NDL +0

END POINT	1/3
	↔↔↔ ↔↔↔
1 AIL	135 100 100 135
2 ELE	135 100 100 135
3 THR	135 100 100 135
4 RUD	135 100 100 135

- Swash plate correction (Except H-1 mode)  
\*If any interactions are noticed, for a description of the linkage correction function, please refer to the SWASH function.

#### 5. Throttle/Pitch curve setting

This function adjusts the throttle or pitch operation curve in relation to the movement of the throttle stick for each condition.

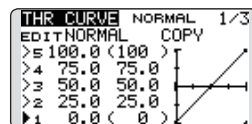

##### <Throttle curve setting example>

Activate the throttle curve of each condition with the condition select switch.

- Normal curve adjustment  
Normal curve creates a basic throttle curve centered near hovering. This curve is adjusted together with the pitch curve (Normal) so that the engine speed is constant and up/down control is easiest.
- Idle up curve adjustment  
The low side Throttle curve creates a curve matched for aerobatics (loop, roll, 3D, etc.).
- Throttle hold curve adjustment  
Confirm that the rate of the slowest position (0%) of the stick is 0% (initial setting).

##### <Example of pitch curve setting>

Activate the pitch curve of each condition with the condition select switch.

- Pitch curve (Normal)  
Make the pitch at hovering approximately +5°~6°. Set the pitch at hovering with the stick position at the 50% point as the standard.  
\*Stability at hovering may be connected to the throttle curve. Adjustment is easy by using the hovering throttle function and hovering pitch function together.
- Pitch curve (Idle up 1)  
The idle up 1 pitch curve function creates a curve matched to airborne flight. Set to -7°~+12° as standard.
- Pitch curve (Idle up 2)  
The high side pitch setting is less than idle up 1. The standard is +8°.
- Pitch curve (Hold)  
At auto rotation, use the maximum pitch at both the high and low sides.  
[Pitch angle setting example]  
Throttle hold: -7°~+12°

## 6. D/R function

D/R function is used to adjust the throw and operation curve of aileron, elevator and rudder for each condition.

\*For throttle and pitch curve settings, refer to the aforementioned "Throttle/Pitch curve setting"

This is normally used after End Point has defined the maximum throw directions.

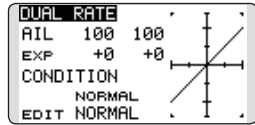

## 7. Gyro sensitivity and mode switching

The gyro sensitivity and mode switching function is utilized to adjust the gyro mixing of the model, and can be set for each condition.

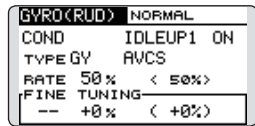

- Normal condition (hovering): Gyro sensitivity maximum
- Idle up 1/Idle up 2/Throttle hold: Gyro sensitivity minimum
- However, during auto rotations with a tail-driven helicopter, this function may not have any effect on the high gyro sensitivity.

## 8. Pitch to RUD mixing setting

**Note: When using a Futaba GY Gyro, or other heading hold gyro, this Pitch to RUD mixing should not be used. The reaction torque is corrected by the gyro. When operating the gyro in the AVCS mode, the mixed signal will cause neutral deviation symptoms and the gyro will not operate normally.**

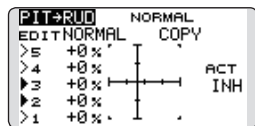

Use this function when you want to suppress the torque generated by the changes in the pitch and speed of the main rotor during pitch operation. Adjust it so that the nose does not swing in the rudder direction. However, when using a heading hold gyro like those shown above, do not use Pitch to rudder mixing.

Activate the Pitch to rudder (Pit -->RUD) mixing

function from the Model Menu, and set the curve for each condition. (At initial setting, this function is in the "INH" state. To use it, set it to the "ON" state.)

### <Setting example>

Activate the mixing curve of each condition with the condition select switch.

A curve setting example is shown below.

- Pitch to RUD mixing curve (Normal)  
Use the hovering system and set this curve to match take off and landing and vertical climb at a constant speed.
- Pitch to RUD mixing (Idle up 1)  
Use this curve in stall turn, loop, and adjust it so the fuselage is facing straight ahead when heading into the wind.
- Pitch to RUD mixing (Hold)  
This function is set so that the fuselage is facing straight ahead at straight line auto rotation. The pitch of the tail rotor becomes nearly 0°.

## 9. Throttle hold setting

\*If throttle hold is necessary, please refer to the THR HOLD function.

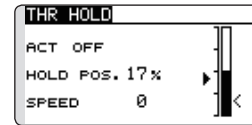

## 10. Throttle cut setting

Throttle cut provides an easy way to stop the engine, by flipping a switch with the throttle stick at idle. The action is not functional at high throttle to avoid accidental dead sticks. The switch's location and direction must be chosen, as it defaults to NULL.

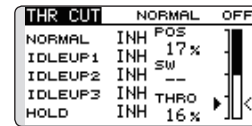

\*With throttle stick at idle, adjust the cut position until the engine consistently shuts off, but throttle linkage is not binding.

## 11. Swash Mix corrects aileron, elevator and pitch interaction

The swash mix function is used to correct the swash plate in the aileron (Left/Right Cyclic) and elevator (Forward/Aft Cyclic) direction corresponding to each operation of each condition.

SWASH MIX	NORMAL	1/2
EDIT		
NORMAL	RATE1	RATE2
AIL→ELE	+0%	+0%
ELE→AIL	+0%	+0%
PIT→AIL	+0%	+0%
PIT→ELE	+0%	+0%

## 12. Throttle mixing setting

\*If throttle mixing is necessary for a compensation for slowing of engine speed caused by swash plate operation during aileron or elevator operation, please refer to the THROTTLE MIX function.

THR MIX	NORMAL	1/2
EDIT		
NORMAL	RATE1	RATE2
AIL→THR	+0%	+0%
ELE→THR	+0%	+0%
RUD→THR	+0%	+0%

## 13. Other special mixings

- Pitch to Needle mixing

This mixing is used with engines with a design which allows needle control during flight (fuel-air mixture adjustment). A needle curve can be set.

- Governor mixing

This mixing is dedicated governor mixing when a governor is used.

---

## SYSTEM MENU

The System Menu sets up functions of the transmitter: This does not set up any model data.

- Call the system menu shown below by touching the SYS button twice at the home screen, etc.

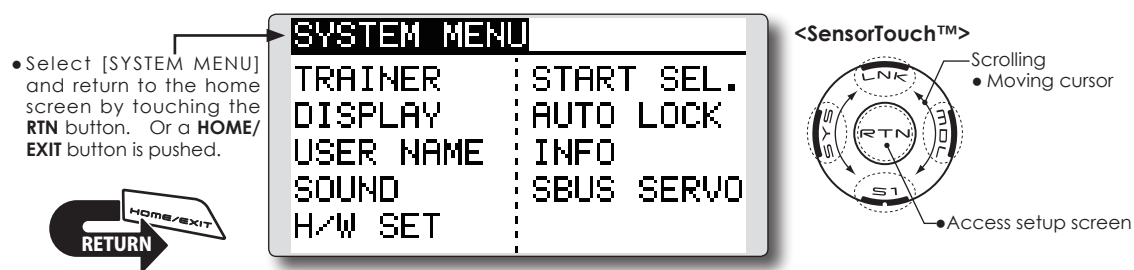

- Select the function you want to set and call the setup screen by touching the RTN button.

---

### System Menu functions table

[TRAINER]: Starts and sets the trainer system.

[DISPLAY]: LCD and back-light adjustment

[USER NAME]: User name registration

[SOUND]: Turns off the buzzer.

[H/W SET]: H/W reverse, calibration and stick mode

[START SEL.]: Immediately, a model selection can be performed

[AUTO LOCK]: The automatic lock function of two kinds of touch sensors

[INFO]: Displays the program version, SD card information, product ID, and language selection.

[SBUS SERVO]: S.BUS servo setting.

T14SG trainer system makes it possible for the instructor to choose which channels and operation modes that can be used in the student's transmitter. The function and rate of each channel can be set, the training method can also be matched to the student's skill level. Two transmitters must be connected by an optional Trainer Cord, and the Instructor's transmitter should be programmed for trainer operation, as described below.

When the Instructor activates the trainer switch, the student has control of the aircraft (if MIX/FUNC/NORM mode is turned on, the Instructor can make corrections while the student has control). When the switch is released the Instructor regains control. This is very useful if the student gets the aircraft into an undesirable situation.

- Setting data are stored to model data.
- Student rate can be adjusted at MIX/FUNC/NORM mode.
- Activated student channels can be selected by switches.

**NOTE: This trainer system can be used in the following manner;**

1. With the T14SG transmitter and a conventional transmitter, if the channel order is different, it is necessary to match the channel order before using this function.

You can select the channel of input data from student's transmitter in the "FUNC" or "MIX" mode.

2. When the T14SG is used as the instructor's transmitter, set the modulation mode of the student's transmitter to PPM.

If being used as the student, T14SG can be connected to the instructor's transmitter which the PPM mode as the student's modulation mode is required. T14SG always sends PPM mode signal from the trainer jack.

3. Be sure that all channels work correctly in both transmitters before flying.

**Corresponding types of transmitters and trainer mode settings:**

Types of transmitters		Instructor's transmitter settings		Student's transmitter settings			Trainer Cords
Instructor	Student	System Type Mod. mode	Trainer setting CH mode	System Type Mod. mode	Trainer setting CH mode	Mod. mode	
T14SG/T18MZ	T14SG/T18MZ	Arbitrary	14CH/16CH	Arbitrary	14CH/16CH	-	T12FG (FUTM4405) and 9C (FUTM4415) Trainer Cords
T14SG	T14MZ, FX-40, T12Z, T12FG, FX-30	Arbitrary	12CH	PCM-G3 2.4G	12CH	PPM	
T14SG	T8FG, FX-20	Arbitrary	12CH 8CH	FASST-MLT2 FASST-MULT	-	-	T12FG (FUTM4405)
T14SG	T10C, T9C, T7C, T6EX, T4EX	Arbitrary	8CH	PPM	-	-	
T14SG	T10CG, T7C	Arbitrary	8CH	Arbitrary	-	-	T12FG (FUTM4405)
T14SG	T8J, T6J	Arbitrary	8CH	Arbitrary	-	-	T12FG (FUTM4405) and 9C (FUTM4415) Trainer Cords
T14MZ, FX-40, T12Z, T12FG, FX-30	T14SG	Arbitrary	12CH	Arbitrary	12CH	-	
T8FG, FX-20	T14SG	Arbitrary	12CH	Arbitrary	12CH	-	
T10C, T10CG, T9C, T7C, T7C, T8J	T14SG	Arbitrary	-	Arbitrary	8CH	-	

- Select [TRAINER] in the System menu and enter the setup screen shown below by touching the RTN button.

• Select the function name and return to the System menu by touching the RTN button. Or the HOME/EXIT button is pushed.

### Mode and switch selection

1. Access the setup screen page 4 shown below by touching the S1 button three times.

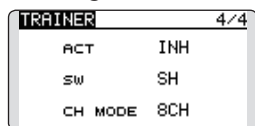

2. Move the cursor to the [ACT] or [12/8CH] item and touch the RTN button to switch to the data input mode.
3. Select the mode by scrolling the touch sensor. The display blinks. Touch the RTN button to change the mode. (To terminate the mode change, touch the S1 button.)

"ACT": Enable operation by changing to [OFF] or [ON].

"12/8 CH": When the student uses the T14SG, T14MZ, T12Z, T12FG or FX-40, select [12CH]. Otherwise select [8CH].

If changing the trainer switch:

4. Move the cursor to the [SW] item and touch the RTN button to access the switch setup screen.

(See "Switch selection method" at the end of this manual for selection method details.)

"SW": Select the desired switch.

Initial setting: SH

\*The switch mode can also be selected when setting the ON position on the switch setup screen. When [ALTERNATE OFF] is selected, normal ON/OFF operation is performed. When [ALTERNATE ON] is selected, the trainer function is alternately turned on and off each time the switch is operated. This allows alternate ON/OFF switching even when a momentary switch (SH) is used.

**Note: The trainer function won't be turned on unless the instructor's transmitter receives signals from the student's transmitter. Be sure to confirm this after connecting your trainer cable.**

### Operating mode selection

(Setup screen page 1-3)

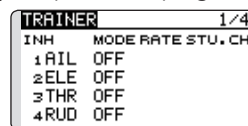

1. Move the cursor to the [MODE] item of the channel you want to change and touch the RTN button to switch to the data input mode.
2. Select the mode by scrolling the touch sensor. The display blinks. Touch the RTN button to change the mode. (To terminate the mode change, touch the S1 button.)

"MODE": Select the desired operation mode for each channel.

NORM: The model is controlled by signals from the student transmitter.

MIX mode: The model is controlled by signals from the instructor and student transmitters. (Reset the student's model data to the default condition.)

FUNC mode (function mode): The model is controlled by signals from the student transmitter with the instructor's setting. (Reset the student's model data to the default condition.)

OFF: Only the instructor side operates.

### Adjusting the student's rate.

\*This can be adjusted for students who may need lower rates than a more experienced student.

- 
1. Move the cursor to the [RATE] item of the channel you want to change and touch the RTN button to switch to the data input mode.
  2. Adjust the rate by scrolling the touch sensor.

"RATE": Adjust the desired rate.

Setting range: 0~100%

Initial value: 100%

\*When you want to reset the value to the initial state, touch the RTN button for one second.

3. To end adjustment, touch the RTN button and return to the cursor mode.

### **Changing the student's channel**

\*The setting above allows setting of the channel assignment of student side when [MIX] or [FUNC] was selected.

1. Move the cursor to the [STU. CH] item of the channel you want to change and touch the RTN button to switch to the data input mode.
2. Select the channel by scrolling the touch sensor. The display blinks. Touch the RTN button to change the channel. (To terminate the mode change, touch the S1 button.)

"STU. CH": Match the channel order of the Instructor's and student's transmitter. This function will help if both transmitters are in different modes, or the Master has a different wing type set up. The student can be set to match the Master without any physical changes being made.

## DISPLAY

LCD and back-light adjustment, unit system

LCD contrast, back-light brightness and back-light off-timer adjustment are possible:

Moreover, a display unit can be chosen from the metric system or yard/pound.

- Select [DISPLAY] at the system menu and access the setup screen shown below by touching the RTN button.

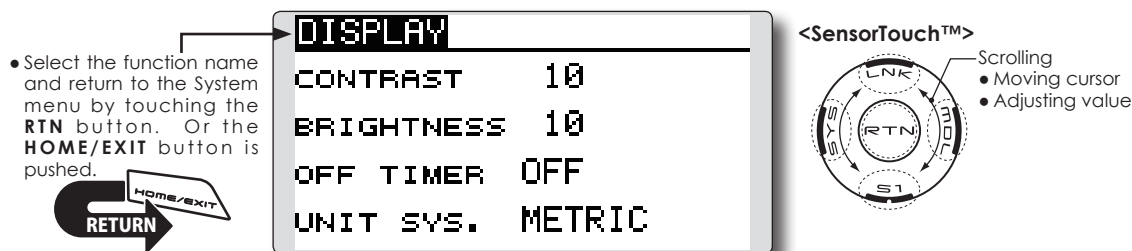

### LCD contrast adjustment

1. Select "CONTRAST" and touch the RTN button to switch to the data input mode and adjust the contrast by scrolling the touch sensor.

"CONTRAST": Adjust the contrast to the desired value while watching the screen display.

Setting range: (Lighter) 0 to 15 (Darker)

Initial value: 5

\*When you want to reset the value to the initial state, touch the RTN button for one second.

2. Touch the RTN button to end adjustment and return to the cursor mode.

### Back-light brightness adjustment

1. Select "BRIGHTNESS" and touch the RTN button to switch to the data input mode and adjust the back-light brightness by scrolling the touch sensor.

"BRIGHTNESS": Adjust the brightness to the desired value while watching the screen display.

Setting range: OFF, 1 to 20(Lighter)

Initial value: 10

\*When you want to reset the value to the initial state, touch the RTN button for one second.

2. Touch the RTN button to end adjustment and return to the cursor mode.

### Back-light off-timer

1. Select "OFF TIMER" and touch the RTN button to switch to the data input mode and adjust the back-light off-timer by scrolling the touch sensor.

"OFF TIMER": Adjust the time when the back-light turns off after operating the touch sensor.

Setting range: 10 to 240 sec (each 10 sec), OFF (always on)

Initial value: 10 sec

\*When you want to reset the value to the initial state, touch the RTN button for one second.

2. Touch the RTN button to end adjustment and return to the cursor mode.

### Unit system adjustment

1. Select "UNIT SYS." and touch the RTN button to switch to the data input mode and adjust the unit by scrolling the touch sensor.

Setting range: (METRIC) or (YARD/POUND)

2. Touch the RTN button to end adjustment and return to the cursor mode.



# USER NAME

User name registration

This function allows the modelers to change the T14SG user name.

\*A name of up to 10 characters can be entered as the user name. Please note that a space is also counted as one character.

- Select [USER NAME] at the System menu and access the setup screen shown below by touching the RTN button.

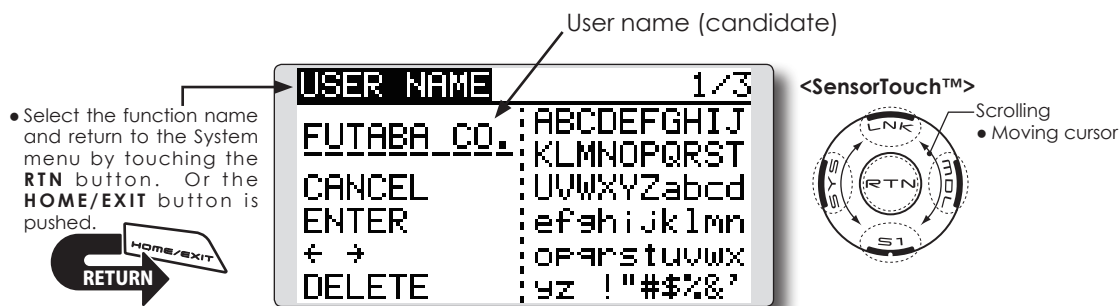

## User name registration

1. Change the user name as described below:

[Moving cursor in user name (candidate)]  
Select [←] or [→], and touch the RTN button.

[Deleting a character]

When [DELETE] is selected and the RTN button is touched, the character immediately after the cursor is deleted.

[Adding a character]

When a character is selected from the character list and the RTN button is touched, that character is added at the position immediately after the cursor.

\*A name of up to 10 characters long can be entered as the user name. (A space is also counted as 1 character.)

2. Upon completing the input, select [ENTER] and touch the RTN button. (To terminate input and return to the original state, select [CANCEL] and touch the RTN button.)

(Character list 1/3)

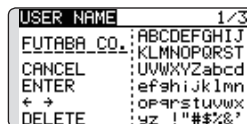

(Character list 2/3)

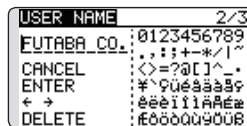

(Character list 3/3)



## SOUND

Turns off the buzzer.

The warning sound and other sounds of the T14SG transmitter can be turned off.

\*When "WARNING" was set to OFF, the no operation alarm (30 minutes), mixing warning sound, and low battery alarm sounds also turned off.

- Select [SOUND] at the system menu and access the setup screen shown below by touching the RTN button.

• Select the function name and return to the System menu by touching the RTN button. Or the HOME/EXIT button is pushed.

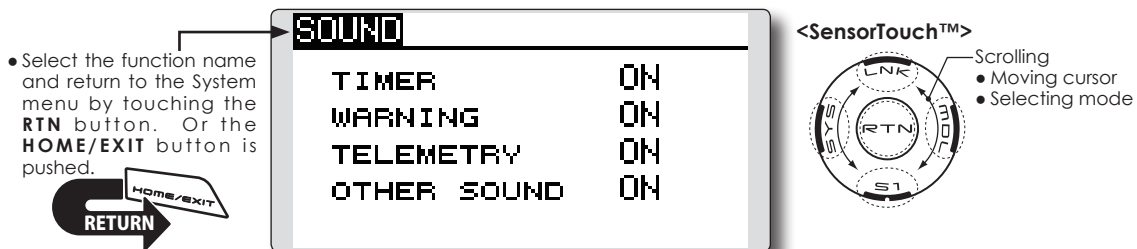

The diagram shows a rectangular screen with the title "SOUND" at the top. Below the title, there is a list of four items, each with a label on the left and a status on the right:

TIMER	ON
WARNING	ON
TELEMETRY	ON
OTHER SOUND	ON

To the left of the screen, there is a circular button with "HOME/EXIT" written above it and "RETURN" written below it. An arrow points from this button to the "SOUND" title on the screen.

To the right of the screen, there is a circular control panel labeled "<SensorTouch™>". It has a central "RTN" button and four outer buttons labeled "LNK", "MOD", "S1", and "SYS". Arrows indicate the direction of scrolling. A legend to the right of the panel lists the following functions:

- Scrolling
- Moving cursor
- Selecting mode

### On/off operation

1. Move the cursor to the [TIMER][WARNING] or [OTHER SOUND] item and touch the RTN button to switch to the data input mode.
2. Select the ON or OFF by scrolling the touch sensor.
  - \*The display blinks.
3. Touch the RTN button.

# H/W SETTING

Hardware reverse and stick mode

## H/W reverse

This function reverses the operation direction of the sticks, switches, trimmer levers, and knobs.

**Note:** This setting reverses the actual operation signal, but does not change the display indicators. Use the Normal mode as long as there is no special reason to use the Reverse mode.

## Stick mode

This function changes the stick mode of transmitter.

**Note:** This will not change the throttle ratchet, etc. Those are mechanical changes that must be performed by a Futaba service center.

**Note:** After changing the mode, these changes are only applied to new models. It is not applied to an existing model.

## Stick calibration

J1-J4 stick correction can be performed.

- Select [H/W SET] at the system menu and access the setup screen shown below by touching the RTN button.

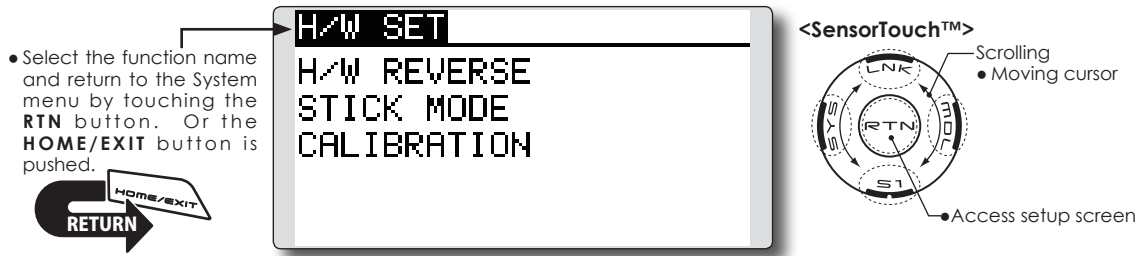

## Operation direction reversal method

1. Select [H/W REVERSE] and access the setup screen shown below by touching the RTN button.

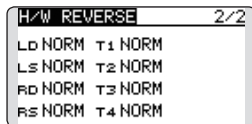
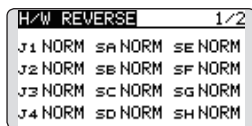

2. Move the cursor to the item corresponding to the H/W (hardware) you want to reverse and touch the RTN button to switch to the data input mode.
3. Select the mode by scrolling the touch sensor. The display blinks. When the RTN button is touched, the operation direction is reversed. (To terminate the mode change, touch the S1 button.)

"NORM": Normal operation direction  
 "REV" : Operation direction is reversed.

## Changing stick mode

1. Select [STICK MODE] and access the setup screen shown below by touching the RTN button.

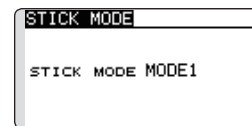

2. Move the cursor to the "STICK MODE" item and touch the RTN button to switch to the data input mode.
3. Select the mode. The display blinks. When the RTN button is touched, the stick mode is changed. (To terminate the mode change, touch the S1 button.)

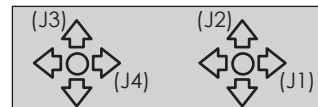

Mode	J1	J2	J3	J4
1	Aileron	Throttle	Elevator	Rudder
2	Aileron	Elevator	Throttle	Rudder
3	Rudder	Throttle	Elevator	Aileron
4	Rudder	Elevator	Throttle	Aileron

---

## Stick calibration method

\*J3 and J4 correction is described below. J1 and J2 corrections are performed using the same procedure.

1. Select [CALIBRATION] and access the setup screen shown below by touching the RTN button.

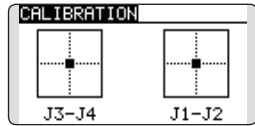

2. Move the cursor to the J3-J4 button and touch the RTN button.

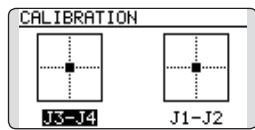

3. Move the J3 or J4 sticks to the neutral position and press the RTN button for one second.

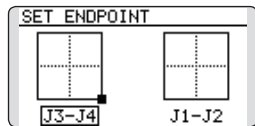

4. Set the J3 and J4 sticks fully to the bottom right and wait until the buzzer sounds.

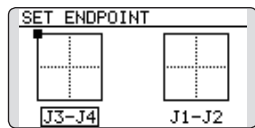

5. Set the J3 and J4 sticks fully to the top left and wait until the buzzer sounds.

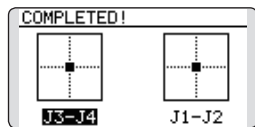

6. The above completes the correction operation. Operate and check if stick correction was performed normally.

## START SEL.

Immediately, a model selection can be performed

START SEL is a function which starts and can perform a model selection immediately.

Each time, it is convenient for the modeler which is enjoying two or more models by one of a transmitter.

### Quick Select Screen

As the name suggests, the Quick Model Select Function enables the modeler to change the selected models rapidly each time the transmitter is

turned ON. With a few quick touches, it is possible to change models whereas before it would require a multi-step process. The T14SG stores up to four models in the Quick Select offerings.

### Model Select Screen

When the transmitter is turned on, it will open to the Model Selection Screen immediately.



### Setting Up and Adjusting the Quick Select Models

1. The Start Selection (START SEL.) menu is accessed through the T14SG System Menu. Turn the transmitter ON and then press the SYS (System) button two times. Use the SensorTouch™ to highlight the Start Selection (START SEL.) and then press the Return (RTN) button to confirm the selection.

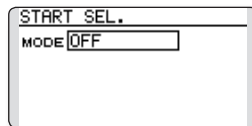

2. The Start Selection (START SEL.) menu option defaults to OFF meaning that Quick Select and Model Select are not applicable. To activate the Quick Select or Model Select, use the SensorTouch to scroll to the OFF setting as denoted in the image. With the OFF indication highlighted, press the Return (RTN) button and rotate the SensorTouch once again to scroll amongst the options. With the Quick Select (QUICK SEL.) indicated, press the Return (RTN) button once again to make the desired selection as indicated.

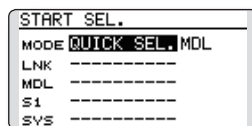

activated, there are two additional options available for customization; ALWAYS and MDL (Model). These options determine if/when the Quick Select information will appear on-screen. ALWAYS, as the name suggests, indicates that each time the transmitter is powered-up, the Quick Select information will appear on-screen. The MDL (Model) setting indicates that the Quick Select information will appear on-screen only when the MDL button is pressed simultaneously as the transmitter is turned ON. With the Quick Select mode highlighted, use the SensorTouch to move to the activation setting options. Model (MDL) is the default setting. Press the Return (RTN) button to bring forth the options, then scroll to the ALWAYS setting using the SensorTouch pad. Press the Return (RTN) button once again to finalize the selection.

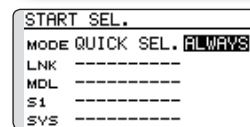
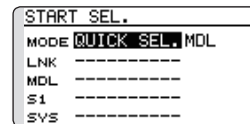

### Quick Select Activation:

With the Quick Select (QUICK SEL.) option

### Assigning models to the sensor buttons:

There are four sensors/buttons that correspond with the SensorTouch: Link (LNK), Model (MDL) System (SYS) and S1. As such, it is possible to offer up to four models available through the Quick Select function. We suggest using the models that you fly most often.

1. Use the SensorTouch, scroll to the desired sensor/button for the first model; for example, Link (LNK).
2. With the input next to the desired sensor highlighted, press the Return (RTN) button one time.
3. Using the SensorTouch, scroll through the available models. To select the desired model, press the Return (RTN) button.
4. Repeat as desired for the remaining sensors.

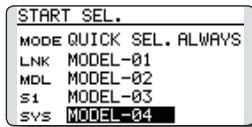

### Using the sensors to select the model:

1. Turn ON the transmitter, activating the Quick Select screen. If Model (MDL) has been selected, please be sure to press the Model (MDL) sensor when powering up the transmitter.

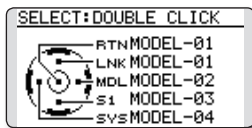

\*Please note: Even if the Quick Select function is active, the Power Mode screen will appear when the transmitter is turned ON while simultaneously pressing the Return (RTN) button.

2. To select the model assigned to a particular sensor, double-click the desired sensor. For example, MODEL- 03 is assigned to S1, double-click S1 to bring forth all settings, etc. for Model -03. The T14SG offers an audible and visual confirmation as the selected model memory is changed accordingly.

\*If the Return (RTN) button is double-clicked, the T14SG the current model is selected as indicated on the display. That is, the model that was used prior to the last time the transmitter was turned OFF.

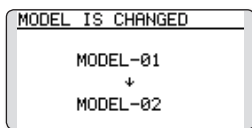

### Model Select Screen

This allows the Model Select screen to be accessed immediately upon turning ON the transmitter.

\*Please note: this function cannot be utilized at the same time as the Quick Select function. If more than four models are flown regularly, we suggest that the Model Select function be utilized as it will save time when selecting the desired aircraft. If four, or fewer, models are flown, the Quick Select option would be the best choice.

\*Please note: the Model Select function does not allow access to the RENAME, COPY or DELETE options. To utilize one of these options, please access the Model Select screen in the typical manner as described in the complete instruction manual.

1. The Start Selection (START SEL.) menu is accessed through the T14SG's System Menu. Turn the transmitter ON and then press the SYS (System) button two times. Use the SensorTouch™ to highlight the Start Selection (START SEL.) and then press the Return (RTN) button to confirm the selection.

2. The Start Selection (START SEL.) menu option defaults to OFF meaning that Quick Select and Model Select are not applicable. To activate the Quick Select or Model Select, use the SensorTouch to scroll to the OFF setting as denoted in the image. With the OFF indication highlighted, press the Return (RTN) button and rotate the SensorTouch once again to scroll to the Model Select (MODEL SEL.). Press the Return (RTN) button once again to activate Model Select as indicated.

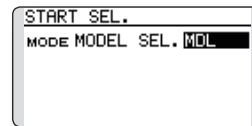

### Model Select Activation:

With the Model Select (MODEL SEL.) option activated, there are two additional options available for customization; ALWAYS and MDL (Model). These options determine if/when the Model Select information will appear on-screen. ALWAYS, as the name suggests, indicates that each time the transmitter is powered-up, the Model Select information will appear on-screen. The MDL (Model) setting indicates that the Model Select information will appear on-screen only when the MDL button is pressed simultaneously as the transmitter is turned ON.

With the Model Select mode highlighted, use the

SensorTouch to move to the activation setting options. Model (MDL) is the default setting. Press the Return (RTN) button to bring forth the options, then scroll to the ALWAYS setting using the SensorTouch pad. Press the Return (RTN) button once again to finalize the selection.

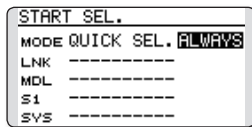
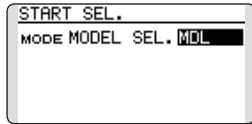

**Using the Model Select Function:**

1. Turn ON the transmitter, activating the Model Select screen. If Model (MDL) has been selected, please be sure to press the Model (MDL) sensor when powering up the transmitter.

\*Please note: Even if the Model Select function is active, the Power Mode screen will appear when the transmitter is turned ON while simultaneously pressing the Return (RTN) button.

2. The SensorTouch is used to select amongst the on-screen models. The current model will automatically be highlighted when the transmitter is turned ON. If a different model is desired, use the SensorTouch to scroll through the available options; each highlighted accordingly. Again, to select a model, press the Return (RTN) button accordingly. The T14SG offers an audible and visual confirmation as the selected model memory is changed.

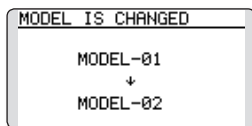
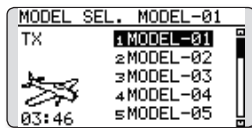

# AUTO LOCK

The automatic lock function of two kinds of SensorTouch

The Auto Lock function makes it possible to lock the transmitter to prevent any unwanted input from your hands while flying.

The auto lock function can be set in two ways.

## LOCK TIMER

Auto Lock functions automatically when there is no operation from the HOME screen display for a chosen number of seconds.

- Select the function name and return to the System menu by touching the RTN button. Or the HOME/EXIT button is pushed.



● **Manual lock**  
If **HOME/EXIT** button is touched **1** second or more from a **HOME** screen, a **SensorTouch** locks manually.

● **Manual lock**  
If **S1** button is touched **1** second or more from a **HOME** screen, a **SensorTouch** locks manually.

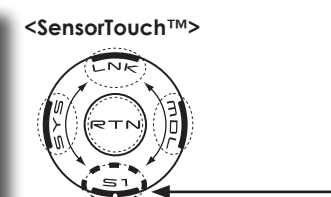
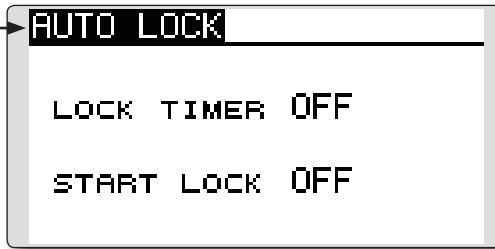

## Auto lock method

1. Open the Auto lock screen in the system menu.

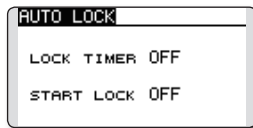

2. Adjust the activation timer for the Auto Lock function. The timer will begin counting immediately when the HOME screen is not used. The timer is adjustable in one second increments up to 30 seconds. If the timer value is OFF, this function is not applicable.

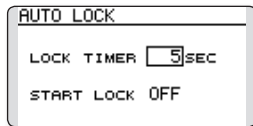

3. The Start Lock setting will, if enabled, automatically lock the T14SG when the transmitter is powered up. To allow access to the transmitter's functions, press and hold the S1 key for one second.

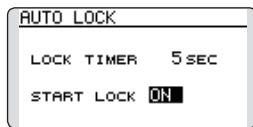

\*If neither the Lock Timer or Start Lock functions are active (OFF), then the key lock remains even if the power is turned off.

\*If the Lock Timer is enabled and the Start Lock is off, the key lock status is canceled each time the T14SG is turned on.

## START LOCK

Auto Lock functions automatically when the model changes or power is turned on.

\*To temporarily allow access to the T14SG programming press and hold the S1 or HOME/EXIT button for one second. Please note, the Auto Lock function timer will resume immediately once again.

● **Lock release**  
Every lock function's touch [ **1** second or more ] of **S1** button will **release** the lock.

● **Lock release**  
Every lock function's touch [ **1** second or more ] of **HOME/EXIT** button will **release** the lock.

● **Display of a lock**  
If locked, there will be sound and the **icon of a key** will come out.

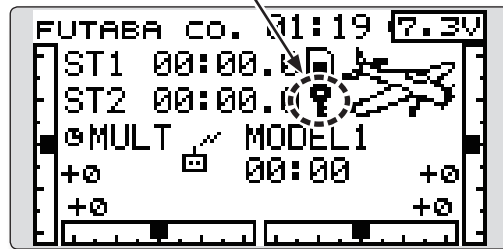

## ⚠ Danger

- ❗ It is recommended to Lock the SensorTouch during flight, to prevent any accidental touches which could change settings and cause an accident.



## INFO

Displays the program version, SD card information, and product ID.

The T14SG system program version information, SD card information (current and maximum number of model data and other files), and product ID are displayed on the Information screen.

The language displayed in home, menu, and setup screen is selectable.

\*When the SD card is not inserted, the SD card information is not displayed.

- Select [INFO] at the system menu and access the setup screen shown below by touching the RTN button.

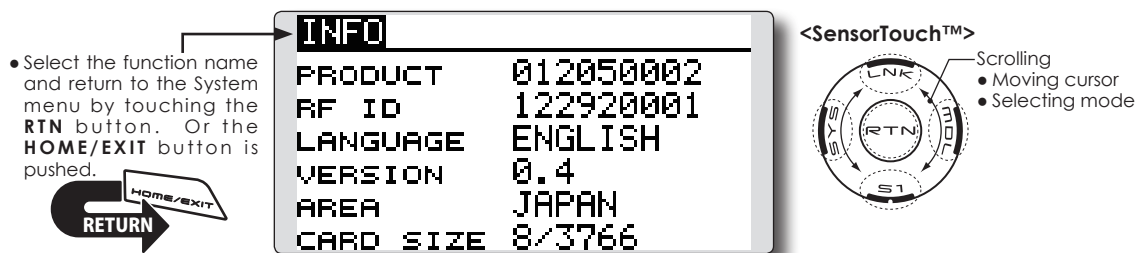

### Information

"PRODUCT": Product ID number  
"RF ID": RF ID number  
"LANGUAGE": The language used in T14SG  
"VERSION": T14SG system program version information  
"AREA": Area which can use T14SG  
"CARD SIZE": Current/Maximum number of model data and other files (SD card)

### Language selection

1. Move the cursor to the "LANGUAGE" item and touch the RTN button to switch to the data input mode.
2. Change the language by scrolling the touch sensor. The display blinks. When the RTN button is touched, the language is changed. (To terminate the change, turn the EDIT dial or push the S1 button.)

## SBUS SERVO

SBUS servo setting.

An S.BUS servo can memorize the channel and various settings you input. Servo setting can be performed on the T14SG screen by wiring the servo as shown in the figure.

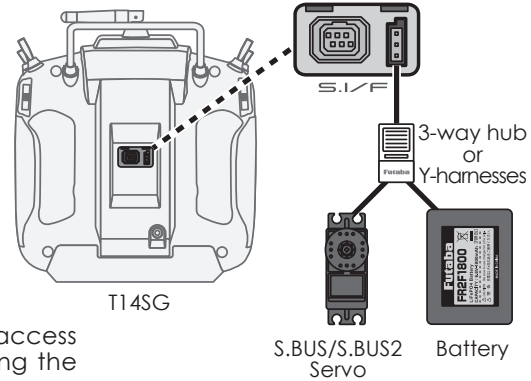

- Select [SOUND] at the system menu and access the setup screen shown below by touching the RTN button.

- Select the function name and return to the System menu by touching the RTN button. Or the HOME/EXIT button is pushed.

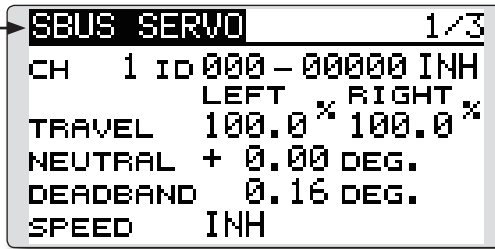

<SensorTouch™>

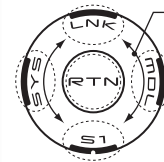

- Scrolling
- Moving cursor
- Selecting mode

### Servo ID number

Individual ID numbers are memorized for your S.BUS(2) servos in your T14SG. When a servo is used, the servo ID number is automatically read by the transmitter. If you use multiple S.BUS(2) servos and do not want to change the settings on all that are mounted in a fuselage, only the desired servo in the group can be set by entering the ID of that specific servo.

- \* S9070SB cannot be arranged by T14SG.
  - \* With some S.BUS(2) servos, there are some functions with cannot be used. If a function cannot be used, the display screen will change.
- (Only the function which can be used by a servo is displayed.)

\* After reading completion, with connection of the above figure, if a stick is moved, the test of operation of the servo can be operated and carried out.

### Procedure for changing S.BUS servo setting

1. Select [SBUS SERVO] of the System Menu.
2. Wire the servo as shown in the figure above.
3. Press [RECALL] on page 3 (S1 is pushed twice). The ID and current setting of that servo are displayed. ([RECALL] is chosen ⇒ RTN is pushed ⇒ RTN is pushed for 1 second)
4. When multiple servos are connected change [INH] at the right side of the ID number on the screen to [ACT] and enter the ID of the servo you want to set.
5. Set each item. (Please see the next page.)
6. Press [WRITE] on page 3 ([WRITE] is chosen ⇒ RTN is pushed ⇒ RTN is pushed for 1 second). The settings are changed.

Push [INIT.], if you would like to initialize a setup of a servo. ([INIT.] is chosen ⇒ RTN is pushed ⇒ RTN is pushed for 1 second)

---

## S.BUS Servo Description of function of each parameter

\*There are a function which can be used according to the kind of servo, and an impossible function.

### • ID

Displays the ID of the servo whose parameters are to be read. It cannot be changed.

### • Channel

Channel of the S.BUS system assigned to the servo. Always assign a channel before use.

### • Reverse

The direction in which the servo rotates can be changed.

### • Servo type

When "Retractable" is selected and the servo has been continuously stopped for 30 seconds, the dead band expands and unnecessary hold current due to external force is eliminated. When a new control signal enters, normal operation is resumed. When using the servo as a landing gear servo, select "Retractable". Also adjust the servo travel to match the landing gear movement range.

### • Soft Start

Restricts operation in the specified direction the instant the power is turned on. By using this setting, the first initial movement when the power is turned on slowly moves the servo to the specified position.

### • Stop Mode

The state of the servo when the servo input signal is lost can be specified. The "Hold" mode setting holds the servo in its last commanded position even if using AM or FM system.

### • Smoother

This function changes smoothness of the servo operation relative to stick movement changes. Smooth setting is used for normal flight. Select the "OFF" mode when quick operation is necessary such as 3D.

### • Neutral Offset

The neutral position can be changed. When the neutral offset is large value, the servo's range of travel is restricted on one side.

### • Speed Control

Speeds can be matched by specifying the operating speed. The speed of multiple servos can be matched without being affected by motor fluctuations. This is effective for load torques below the maximum torque.

However, note that the maximum speed will not be exceed what the servo is capable of even if the servos operating voltage is increased.

### • Dead band

The dead band angle at stopping can be specified.

#### [Relationship between dead band set value and servo operation]

Small → Dead band angle is small and the servo is immediately operated by a small signal change.

Large → Dead band angle is large and the servo does not operate at small signal changes.

**(Note)** If the dead band angle is too small, the servo will operate continuously and the current consumption will increase and the life of the servo will be shortened.

### • Travel Adjust

The left and right travels centered about the neutral position can be set independently.

### • Boost

The minimum current applied to the internal motor when starting the servo can be set. Since a small travel does not start the motor, it essentially feels like the dead band was expanded. The motor can be immediately started by adjusting the minimum current which can start the motor.

#### [Relationship between boost set value and servo operation]

Small → Motor reacts to a minute current and operation becomes smooth.

Large → Initial response improves and output torque increases. However, if the torque is too large, operation will become rough.

---

- **Boost ON/OFF**

OFF : It is the boost ON at the time of low-speed operation.(In the case of usual)

ON : It is always the boost ON.(When quick operation is hope)

- **Damper**

The characteristic when the servo is stopped can be set.

When smaller than the standard value, the characteristic becomes an overshoot characteristic. If the value is larger than the standard value, the brake is applied before the stop position.

Especially, when a large load is applied, overshoot, etc. are suppressed by inertia and hunting may occur, depending on the conditions. If hunting (phenomena which cause the servo to oscillate) occurs even though the Dead Band, Stretcher, Boost and other parameters are suitable, adjust this parameter to a value larger than the initial value.

**[Relationship between damper set value and servo operation]**

Small → When you want to overshoot. Set so that hunting does not occur.

Large → When you want to operate so that braking is not applied. However, it will feel like the servo response has worsened.

**(Note)** If used in the hunting state, not only will the current consumption increase, but the life of the servo will also be shortened.

- **Stretcher**

The servo hold characteristic can be set. The torque which attempts to return the servo to the target position when the current servo position has deviated from the target position can be adjusted.

This is used when stopping hunting, etc., but the holding characteristic changes as shown below.

**[Relationship between stretcher and servo operation]**

Small → Servo holding force becomes weaker.

Large → Servo holding force becomes stronger.

**(Note)** When this parameter is large, the current consumption increases.

- **Buzzer**

When the power supply of a servo is previously turned on at the time of a power supply injection without taking transmit of a transmitter, the buzzer sound of about 2.5 Hz continues sounding from a servo.

(Even when the transmit of a transmitter is taken out previously, a buzzer becomes until the signal of a servo is outputted normally, but it is not unusual.)

The transmitter has been turned OFF ahead of a servo power supply → The buzzer sound of about 1.25 Hz continues sounding as servo power supply end failure alarm.

(Do not insert or remove the servo connector while the receiver power is ON. A buzzer may sound by incorrect recognition.)

\* Buzzer sound is generated by vibrating the motor of a servo.

Since current is consumed and a servo generates heat, please do not operate the number more than needed or do not continue sounding a buzzer for a long time.

## FUNCTIONS OF LINKAGE MENU

The Linkage Menu is made up of functions which perform model addition, model type selection, system type, end point setting, and other model basic settings.

The functions which can be selected depend on the model type. A typical menu screen is shown below.

- Access the Linkage menu shown below by tapping the LNK button two times.

- Select the function name and return to the Linkage menu by touching the RTN button. Or a HOME/EXIT button is pushed.

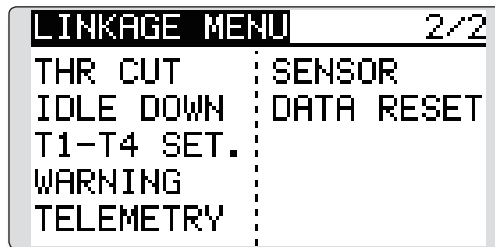
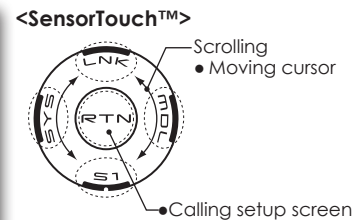
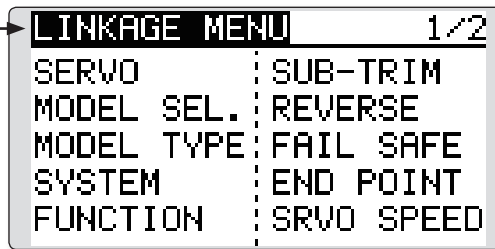

\*The display screen is an example. The screen depends on the model type.

- Select the function you want to set and call the setup screen by touching the RTN button.

### Linkage Menu functions table

- [SERVO]: Displays the servo test and operation position
- [MODEL SEL.]: Model addition, call, deletion, copy, model name setting
- [MODEL TYPE]: Model type, wing type, swash type, etc. selection
- [SYSTEM]: System mode selection, link of a transmitter and receiver, area mode selection
- [FUNCTION]: Channel assignment of each function can be changed
- [SUB-TRIM]: Adjusts the neutral position of each servo
- [REVERSE]: Reverses the servo travel direction
- [FAIL SAFE]: Fail safe function and battery fail safe function setting
- [END POINT]: Servo travel adjustment and limit setting
- [SERVO SPEED]: Speed setup of a servo
- [THR CUT]: Stops the engine safely and easily (airplane and helicopter only)
- [IDLE DOWN]: Lowers the idle speed of the engine (airplane only)
- [SWASH RING]: Limits the swash plate travel to within a fixed range. (helicopter only)
- [SWASH]: Swash AFR and linkage correction function (helicopter only)
- [T1-T4 SET.]: Control step amount and mode selection of the digital trim
- [WARNING]: Mixing warning normal reset
- [TELEMETRY]: Displays various data sent from the receiver.
- [SENSOR]: Various telemetry sensors setting
- [DATA RESET]: Model memory set data reset

## SERVO MONITOR Servo Test & Graph Display / Displays servo positions.

This is used for testing servo movement. “Moving Test” (repetition mode) and “Neutral Test” (fixed position mode) are available.

The “Neutral Test” is good for finding the neutral position of a servo horn.

In order to prevent any potential difficulties, the servo test function will be inoperable, or inaccessible, under certain conditions. Specifically, the Servo Test function is not operational if the Throttle Cut is ON in either airplane or helicopter modes; or if the Throttle Hold is ON in Helicopter mode.

- A [U.MENU/MON.] button is pushed once from a home screen.
- Select [SERVO] in the Linkage menu and access the setup screen shown below by touching the RTN button.

- Select the function name and return to the Linkage menu by touching the RTN button. Or the HOME/EXIT button is pushed.

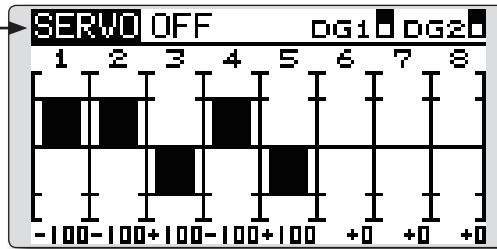

<SensorTouch™>

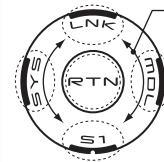

- Scrolling
- Moving cursor
- Selecting mode

### Servo test operation

1. Move the cursor to the [OFF] item and touch the RTN button to switch to the data input mode.

Select the test mode by scrolling the touch sensor and touch the RTN button. The display blinks. Touch the RTN button to change the mode. (To terminate mode change, touch the S1 button.)

[MOVING]: Mode which repeats operation of each servo

[NEUTRAL]: Mode which locks each servo in the neutral position

2. Move the cursor to the [MOVING] or [NEUTRAL] item and touch the RTN button to switch to the data input mode.

Select the [OFF] by scrolling the touch sensor and touch the RTN button. Testing is stopped.

## MODEL SELECT

The Model Selection function performs model addition, selection, deletion, copy, and model name setting.

This function is used to load the settings of the desired model into the T14SG's memory.

The settings may be selected from either the transmitter's internal memory or an SD card. Remember that up to 30 model memories are available in the transmitter.

The name of the model stored in the transmitter and the SD card may be changed. This can be very useful to tell different models settings apart. Each model name can be as long as 10 characters, and the model name always appears in the display screen.

The Copy function is used to copy parameters, settings, etc. from one model data into a second memory. It may be used for getting a head-start on setting up models with almost the same settings (only differences need to be modified, instead of entering the complete model from scratch). Also, this function may be used to make a backup copy of a model setup before any changes are made.

\*T14SG can use the model data of T8FGS for SD card, copying it. However, the model data of T14SG cannot be used by T8SG (S).

- Select [MODEL SELECT] in the Linkage menu and access the setup screen shown below by touching the RTN button.

- Select the function name and return to the Linkage menu by touching the RTN button. Or the HOME/EXIT button is pushed.

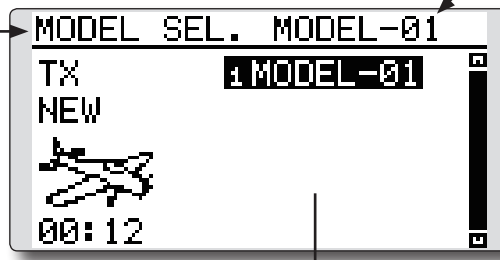

(Model list)

Current model

<SensorTouch™>

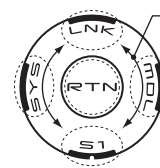

- Scrolling
- Moving cursor
- Selecting mode

\*The display screen is an example. The screen depends on the model type.

### Model selection

\*Model data saved on the transmitter memory other than the model currently used can be selected.

1. Move the cursor to the save destination display ("TX" or "CARD") and touch the RTN button to switch to the data input mode. Select the save destination by scrolling the touch sensor and touch the RTN button.  
[TX]: Transmitter memory  
[CARD]: SD card
2. After moving the cursor to the desired model in the model list, touch the RTN button.
3. Move to [SELECT].
4. Touch the RTN button. A confirmation message is displayed. Touch the RTN button for one second and selection is complete.

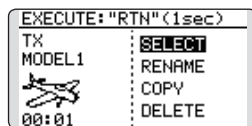

\*Transmission stops and then starts in the new model.

### Model addition

\*A new model can be added to the transmitter memory. It can not be added to the SD card.

1. Move the cursor to [NEW].
2. Touch the RTN button. A confirmation message appears. Touch the RTN button for one second.



\*The model type setup screen and frequency setup screen are automatically displayed. Confirm or change the model type and SYSTEM mode.

\*Transmission stops and then starts in the new model.

\*The added model appears in the model list of the model select setup screen.

**\*Link is required when a new model is made from a model selection.**

## Model deletion

\*The model stored in the transmitter memory or an SD card can be deleted.

\*The current model can not be deleted.

1. Move the cursor to the save destination display ("TX" or "CARD") and touch the RTN button to switch to the data input mode.  
Select the save destination by scrolling the touch sensor and touch the RTN button.  
[TX]: Transmitter memory  
[CARD]: SD card
2. Move the cursor to the model you want to delete in the model list and then touch the RTN button.
3. Move the cursor to [DELETE].
4. Touch the RTN button. When a confirmation message is displayed and the RTN button is touched for one second, the model is deleted.

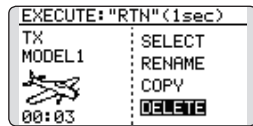

## Model name change

\*The model name of the model stored in the transmitter memory or a SD card can be changed.

1. If changing the location:  
Move the cursor to the save destination display ("TX" or "CARD") and touch the RTN button to switch to the data input mode.  
Select the save destination by scrolling the touch sensor and touch the RTN button.  
[TX]: Transmitter memory  
[CARD]: SD card
2. Move the cursor to the model you want to change in the model list and then touch the RTN button.
3. Move to [RENAME].
4. Touch the RTN button.

\*The model name setup screen is displayed.

User name (candidate)



5. Change the model name as described below:  
[Moving cursor in the user name (candidate)]  
Select [←] or [→], and touch the RTN button.  
[Deleting a character]  
When [DELETE] is selected and the RTN button is touched, the character immediately after the cursor is deleted.

## [Adding a character]

When a character is selected from the character list and the RTN button is touched, that character is added at the position immediately after the cursor.

\*A name of up to 10 characters long can be entered as the model name. (A space is also counted as one character.)

6. After the desired information has been input, select [ENTER] and touch the RTN button. (To terminate input and return to the original state, select [CANCEL] and touch the RTN button.)

## Model copy

\*A copy can be made of the model stored in the transmitter memory or an SD card.

1. If changing the location:  
Move the cursor to the save destination display ("TX" or "CARD") and touch the RTN button to switch to the data input mode.  
Select the save destination by scrolling the touch sensor and touch the RTN button.  
[TX]: Transmitter memory  
[CARD]: SD card
2. Select the model you want to copy in the model list and then touch the RTN button.
3. Move to [COPY].
4. Touch the RTN button.

\*The copy screen appears.



5. If replacing the model stored in the transmitter memory:  
Move to [ADD-LIST] and touch the RTN button to switch to the data input mode.  
Select the destination model by scrolling the touch sensor and touch the RTN button.  
[ADD-LIST]: adding the model to the list [(model name)]: replacing the model  
\*The model stored in the SD card can be replaced.

## If changing the location:

- Move the cursor to the copy destination display ("TX" or "CARD") and touch the RTN button to switch to the data input mode.  
Select the save destination by scrolling the touch sensor and touch the RTN button.
6. Move to [COPY].
7. Touch the RTN button. When a confirmation message is displayed and the RTN button is touched for one second, the model data is copied.



## MODEL TYPE

This function selects the model type from among airplane, helicopter, and glider.

Six swash types are available for helicopters. Six types of main wings and three types of tail wings are available for airplanes and gliders. Functions and mixing functions necessary for each model type are set in advance at the factory.

**Note: The Model Type function automatically selects the appropriate output channels, control functions, and mixing functions for the chosen model type.**

**When the Model Type selection command is accessed, all of the data in the active memory is cleared (except the following swash type.) Be sure that you don't mind**

**losing this data, or back it up to another memory using the copying functions.**

**When changing the helicopter swash type within the following groups, you can leave the settings other than the SWASH function. However, this is initialized when you change the swash type to the other swash type group.**

<b>Swash type group A:</b> H-1, H-3, HR3, and HE3 <b>Swash type group B:</b> H-4, H-4X
---

- Select [MODEL TYPE] in the Linkage menu and access the setup screen shown below by touching the RTN button.

- Select the function name and return to the Linkage menu by touching the RTN button. Or the HOME/EXIT button is pushed.

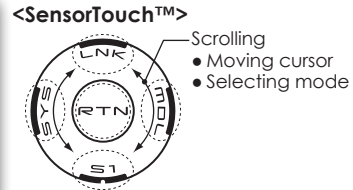
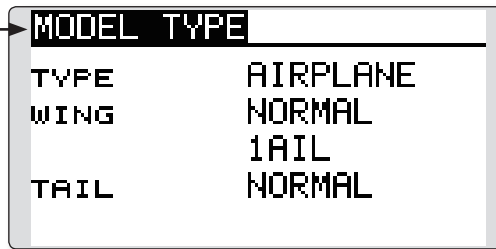

(The display screen is an example. The screen depends on the model type.)

### Model type selection

1. Move the cursor to the item you want to change and touch the RTN button to switch to the data input mode.

Select the desired type by scrolling the touch sensor and touch the RTN button. A confirmation message appears. Touch the RTN button for one second.

Move to [YES] and Touch the RTN button for one second.

(To terminate input and return to the original state, touch the S1 button or select [NO] and touch the RTN button.)

"TYPE": Model type

"WING " (airplane/glider): Wing type

"TAIL" (airplane/glider): Tail type

"SWASH" (helicopter): Swash type

\*The wing types which can be selected depend on the mode; FASST, Multi-ch, or 7ch, etc.

2. If resetting the data when changing the helicopter swash type:

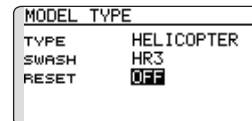

(Helicopter)

Move the cursor to [OFF] and touch the RTN button to switch to the data input mode.

Select [ON] by scrolling the touch sensor and touch the RTN button. A confirmation message appears. Touch the RTN button.

Activate the swash type setting. The swash setting parameters are reset.

## Model type selection (Airplane, Glider)

### •Wing type (Normal)

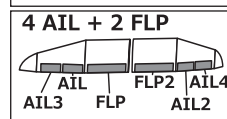
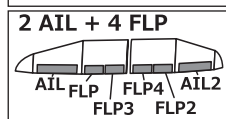
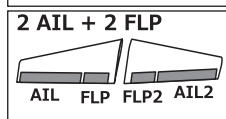
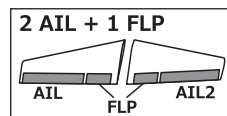
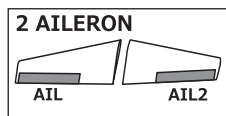
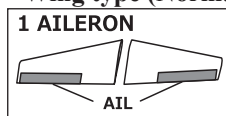

### •Wing type (Tailless wing)

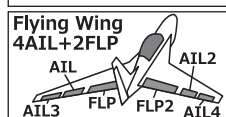
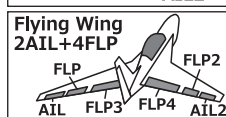
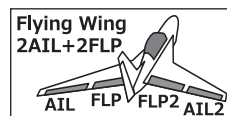
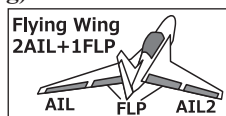
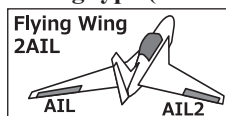

### •Rudder type

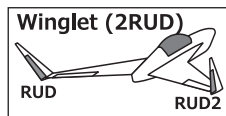
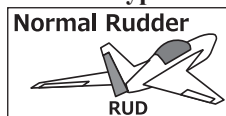

### •Tail type

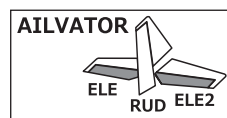
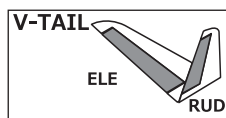
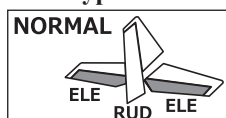

## Model type selection (Helicopter)

### •Swash type

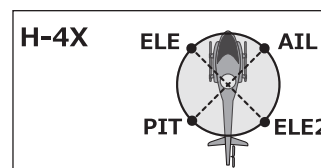
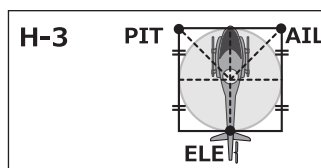
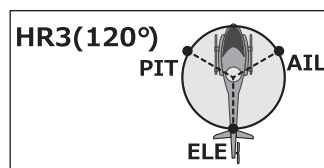
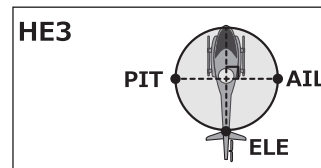
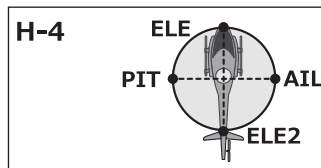
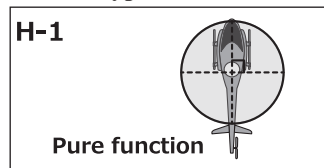

## System Type selection

The T14SG is for 2.4GHz only. The system can be changed from among 5 choices: FASSTest 14CH, FASSTest 12CH, FASST MULTI, FASST 7CH, S-FHSS. It is FASSTest14CH and FASSTest12CH which can be chosen by R7008SB set. The method of selection is to the next page.

- \*If you change the System Type, other model data is not reset.
- \*If a system type is changed in Helicopter mode, the transmitter will offer two selections:
- [Yes] : Selection sets the channel order suitable for System Type. (We recommend here. )
- [No] : The present channel order is maintained.
- \*After any change, remember to test the model and should fully check servo direction and a motion.
- \*Analog servos cannot be used with the R7008SB in the

FASSTest 12CH mode.

## Dual receiver function (only FASSTest 14CH mode)

Dual receivers can be linked with the T14SG. Two receivers are recognized individually by ID numbers. For example, in R7008SB, CH output setting function is used, by setting the first as "1-8CH", and setting the second as "9-14CH", two sets of receivers can be used as a set in the model, allowing you 14 channels. If a Dual receiver function is used, the following function can set up individually.

- Battery fail-safe voltage setup
- Telemetry function ON/OFF
- Sensor setup

- Select [SYSTEM] in the Linkage menu and access the setup screen shown below by touching the RTN button.

- Select the function name and return to the Linkage menu by touching the RTN button. Or the HOME/EXIT button is pushed.

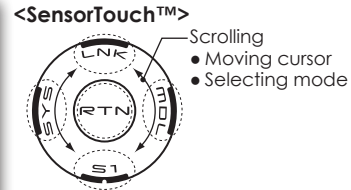
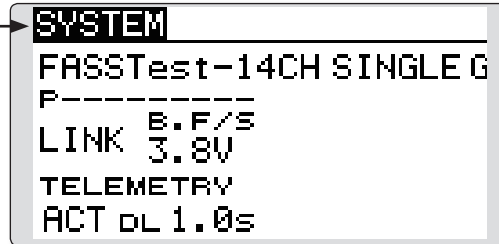

## Area mode selection (Frequency range)

The T14SG transmitter has been designed to function in many countries. If you will be utilizing this transmitter in a country other than France, please make sure that [AREA] is set to "G". If, however, this transmitter will be utilized in France, it must be set to "F" in order to comply with French regulations.FASST mode selection

### Cases when linking is necessary:

- When using a receiver other than the initial setting.
- When the communication system was changed. (FASSTest14CH ↔ FASSTest12CH etc.)
- When a new model was created by model selection.

## Receiver linking

The receiver will only be controlled (without being affected by other transmitters) by the transmitter it is linked to. When using a receiver other than one purchased as a set, linking is necessary.

Moreover, a re-link is required when a new model is added by model selection, and the time of system type change.

Linking method **P.37**

## Battery fail-safe voltage setup (only FASSTest mode)

The voltage which battery fail-safe activates, can be set when you link. (3.5-8.4V) The receiver memorizes the setting as it was at link.

Suggested setting voltages are as follows.

- 4 cells NiCd or NiMH (Normal: 4.8v) = 3.8 v
- 2 cells LiFe (Normal: 6.6 v) = 6.0 ~ 6.2 v
- 2 cells LiPo (Normal: 7.4 v) = 7.2 ~ 7.4 v

It is a rough reference value.

Since it changes with servos carried in the condition and the model of a battery, please set to your own model in a battery consumption current.

### Telemetry function (FASSTest mode only)

To use the telemetry function, set “Telemetry” to “ACT”.

### DL Interval (FASSTest mode only)

When a telemetry function is enabled, the receiving interval (down-link interval) of sensor data can be changed.

If a DL interval is increased, the response of the sensor data display becomes slower, but stick response will improve.

### System Type selection procedure

1. Move the cursor to the [FASSTest-14CH] item and touch the RTN button to switch to the data input mode.

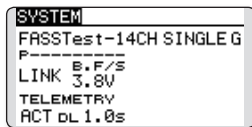

2. Select the system type by scrolling the touch sensor.  
[FASSTest-14CH][FASSTest-12CH][FASST-MULT][FASST-7CH][S-FHSS]

\*An example of selections for each system is on the following page.

3. Touch the RTN button to end adjustment and return to the cursor mode.

### Dual receiver function (only FASSTest 14CH mode) procedure

1. Move the cursor to the [SINGLE] item and touch the RTN button to switch to the data input mode.

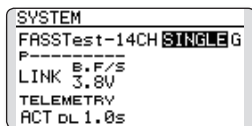

2. Select the [SINGLE] or [DUAL] by scrolling the touch sensor.

ID of a Primary receiver displays.

ID of a Secondary receiver displays.

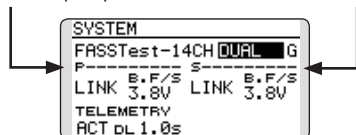

In DUAL, a primary receiver is link previously. Next, a secondary receiver is link.

3. Touch the RTN button to end adjustment and return to the cursor mode.

### Area mode selection (Frequency range) procedure

1. Move the cursor to the [G] item and touch the RTN button to switch to the data input mode.

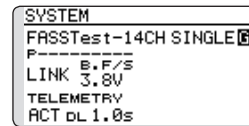

2. Select the [G] or [F] by scrolling the touch sensor.  
\*“F” is chosen only when using the transmitter is used in France. Leave this in “G” otherwise.
3. Touch the RTN button to end adjustment and return to the cursor mode.

### Telemetry ACT/INH procedure

1. Move the cursor to the TELEMETRY [ACT] item and touch the RTN button to switch to the data input mode.

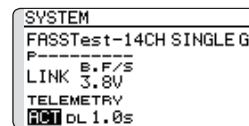

2. Select the [ACT] or [INH] by scrolling the touch sensor.
3. Touch the RTN button to end adjustment and return to the cursor mode.

### DL Interval set procedure

1. Move the cursor to the TELEMETRY DL [1.0s] item and touch the RTN button to switch to the data input mode.

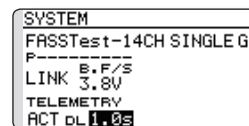

2. Select the DL time by scrolling the touch sensor. If a DL interval is increased, the response of the sensor data display becomes slower, but stick response will improve.

Initial value: 1.0s

Adjustment range : 0.1s~2.0s

3. Touch the RTN button to end adjustment and return to the cursor mode.

## The example for choosing System Type

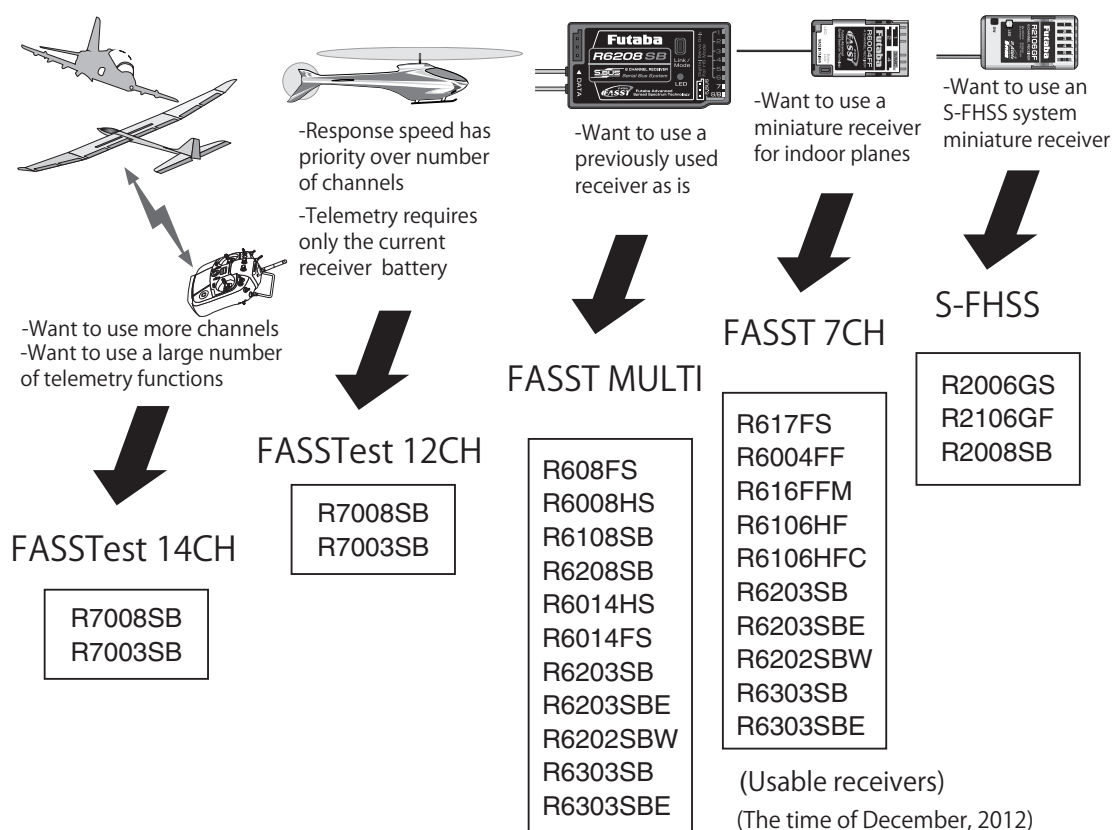

### System Type

- **FASSTest 14CH** --- FASSTest system receiver mode. Applicable with the telemetry sensor unit. Up to 18 channels (linear 12+ON/OFF2) can be used.
- **FASSTest 12CH** --- FASSTest system receiver mode. Applicable with receiver voltage display. Up to 12 channels (linear 10+ON/OFF2) can be used. Telemetry Sensor cannot be used, but the response speed is a faster than that of the 14CH mode.
  - Analog servos cannot be used with the R7008SB in the FASSTest 12CH mode.
- **FASST MULTI** --- FASST-MULTI system receiver mode. Up to 14 channels (linear 12+ON/OFF2) can be used.
- **FASST 7CH** --- FASST-7CH system receiver mode. Up to 7 channels can be used.
- **S-FHSS** --- S-FHSS system receiver mode. Up to 8 channels can be used.

## FUNCTION

Channel assignment of each function can be changed.

When you select model and wing (swash) types, you will find that the optimized combinations of servo output channels and functions have been already preset. If you would like, you can freely change combinations of servo output channels, functions (aileron, elevator, etc), and control (sticks, switches, and trim levers).

\*You can also assign the same function to multiple servo output channels such as assigning elevator function to CH2 and CH3.

### Channel Replacement

When the channel is replaced in the Function menu, replaced channel uses the setting data (ATV, SUB-TRIM, REVERSE, F/S, and B-F/S, etc.).

### Servo Output Channels

For FASSTest 14CH mode, you can set 12 linear channels and two digital channels. For FASSTest 12CH mode, you can set 10 linear channels and two digital channels. For FASST MULT mode, you can set 12 linear channels and two digital channels.

For FASST 7CH mode, you can set only 7 linear channels. For S-FHSS mode, you can set only 8 linear channels.

\*DG1/2 (digital channels)

These channels can function as switched channels. You can freely change combinations between servo output channels and input controls (sticks, switches, and trim levers).

### Motor Function

If you have either a Glider or Airplane Model Type selected, and choose to activate the Motor function, a reverse setting screen is displayed.

\*If YES is selected, the output is reversed. If NO is selected, the output is normal.

### Warning

As a safety precaution to prevent the motor from starting unexpectedly, please switch off the motor accordingly. We also suggest removing the propeller from the motor as an additional precaution.

- Select [FUNCTION] in the Linkage menu and access the setup screen shown below by touching the RTN button.
- Select the function name and return to the Linkage menu by touching the RTN button. Or the HOME/EXIT button is pushed.

FUNCTION	NORMAL	1/4
1 AIL	J1	T1 SEPAR
2 ELE	J3	T3 SEPAR
3 THR	J2	T2 SEPAR
4 RUD	J4	T4 SEPAR

• Trim operation mode "COMB": Combination mode "SEPAR": Separate mode It sets up by T1-T4 SET of LINKAGE MENU.

• Scrolling  
• Moving cursor  
• Selecting mode  
• Adjusting value

• To next page

(The display screen is an example. The screen depends on the model type.)

### Function change

1. Move the cursor to the function item of the channel you want to change and touch the RTN button.

\*The function selection screen is displayed.

2. Move the cursor to the function name you want to set and touch the RTN button.

\*The function name blinks.

3. Touch the RTN button to execute the change. (When you want to cancel this operation, touch the S1 button.)

\*Multiple channels can be assigned to one function.

### Operation control change

1. Move the cursor to the "CTRL" item of the channel you want to change and touch the RTN button.

\*The control selection screen is displayed.

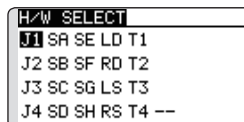

2. Move the cursor to the control you want to change, and touch the RTN button.

\*The same control can be assigned to multiple channels.

## Camber/Motor/Butterfly control setting (glider)

\*Camber/Motor/Butterfly function control can be changed for each condition.

FUNCTION	NORMAL	3/4
	CTRL TRIM	
9 CAMB	LS G	--
10 BFLY	J2 G	--
11 MOT	SG G	--
12 AUX1	--	--

Camber, Motor or Butterfly control group/single setting is performed at the function setup screen.

"G": Group (common to all conditions)

"S": Single (set for each condition)

## Trim setting

Move the cursor to the "TRIM" item of the channel you want to change and touch the RTN button.

\*The trim setup screen is displayed.

H/W SELECT		
J1 SA SE LD T1	RATE	
J2 SB SF RD T2	+30%	
J3 SC SG LS T3	MODE	
J4 SD SH RS T4	NORMAL	
		--

The following items can be set at the trim setup screen:

## Trim selection

Move the cursor to the trim, lever, etc. you want to set and touch the RTN button.

\*The setting can be changed.

## Trim rate setting

Move the cursor to the [RATE] item and touch the RTN button to switch to the data input mode.

Set the trim rate by scrolling the touch sensor.

Initial value: +30%

Adjustment range : -150~+150%

(When the RTN button is touched for one second, the trim rate is reset to the initial value.)

Touch the RTN button to end adjustment and return to the cursor mode.

## Trim mode selection

Move the cursor to the [MODE] item and touch the RTN button to switch to the data input mode.

Select the trim mode by scrolling the touch sensor. A confirmation message appears.

Touch the RTN button to change the mode. (To terminate input and return to the original state, touch the S1 button.)

[NORM]: Normal mode. Normal trim (parallel shift trim) operation.

[ATL]: ATL operation mode. Maximum change near idle or low-stick position, normally used with throttle trim. It is also possible to reverse the travel.

\*[NORMAL]/[REVERSE] selection is possible in "ATL" mode.

## Throttle trim (helicopter only)

\*The throttle trim in conditions other than "Normal" condition can be inhibited.

When other than normal condition is selected, move the cursor to throttle trim on the function setup screen and touch the RTN button for 1 second.

FUNCTION	IDLEUP1	1/4
	CTRL TRIM	
1 AIL	J1	T1 SEPAR
2 ELE	J3	T3 SEPAR
3 THR	J2	X T2 SEPAR
4 RUD	J4	T4 SEPAR

\*When "X" is displayed, THR trim is inhibited in conditions other than normal condition.

## Channel replacement

Move the cursor to the channel # you want to replace and touch the RTN button to switch to the data input mode.

Select the destination channel # by scrolling the touch sensor. A confirmation message appears. Touch the RTN button to replace the channel. (To terminate input and return to the original state, touch the S1 button.)

## SUB-TRIM

Setting of neutral position of each servo.

The Sub-Trim function is used to set the servo neutral position, and may be used to make fine adjustments to the control surface after linkages and pushrods are hooked up. When you begin to set up a model, be sure that the digital trims are set to their center position.

- Select [SUB-TRIM] in the Linkage menu and access the setup screen shown below by touching the RTN button.

• Select the function name and return to the Linkage menu by touching the RTN button. Or the HOME/EXIT button is pushed.

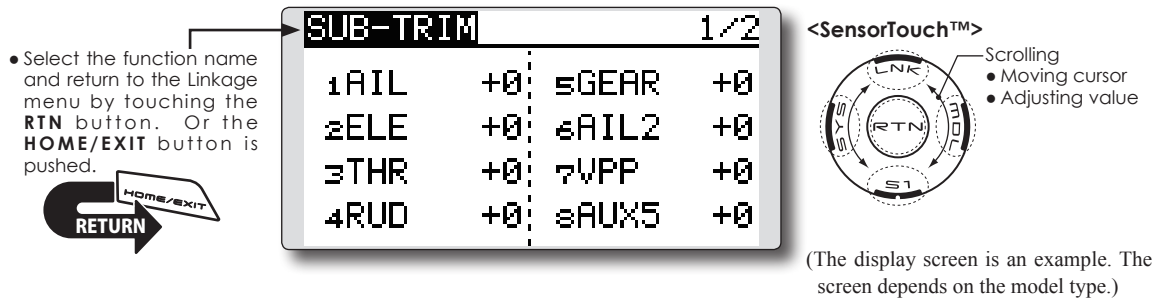

The diagram shows a rectangular display screen titled "SUB-TRIM" with a page indicator "1/2" in the top right corner. The screen displays a table of servo channels with their current values:

1AIL	+0	5GEAR	+0
2ELE	+0	6AIL2	+0
3THR	+0	7VPP	+0
4RUD	+0	8AUX5	+0

Below the screen, a circular "SensorTouch" control panel is shown. It features a central "RTN" button and several outer buttons labeled "LNK", "MOD", "S1", and "SYS". A legend indicates that the panel is used for "Scrolling", "Moving cursor", and "Adjusting value".

(The display screen is an example. The screen depends on the model type.)

### Sub-trim adjustment

1. Move the cursor to the channel you want to adjust and touch the RTN button to switch to the data input mode.
2. Adjust the rate by scrolling the touch sensor.  
Initial value: 0  
Adjustment range: -240~+240 (steps)  
(When the RTN button is touched for one second, sub-trim is reset to the initial value.)  
\*Before sub-trim adjustment, it is very important to adjust the linkages at the control surface so that you do not use sub-trim, except for very minute adjustments.
3. Touch the RTN button to end adjustment and return to the cursor mode.
4. Repeat this procedure for each channel.



## REVERSE

Use to reverse the throw direction.

Servo Reverse changes the direction of an individual servo's response to a control input.

For CCPM helicopters, be sure to read the section on Swash AFR before reversing any servos. With CCPM helicopters, always complete your servo reversing prior to any other programming. If you use pre-built Airplane/Sailplane functions that control multiple servos, it may be confusing

to tell whether the servo needs to be reversed or a setting in the function needs to be reversed. See the instructions for each specialized function for further details. Always check servo direction prior to every flight as an additional precaution to confirm proper model memory, hook ups, and radio function.

- Select [REVERSE] in the Linkage menu and access the setup screen shown below by touching the RTN button.

• Select the function name and return to the Linkage menu by touching the RTN button. Or the HOME/EXIT button is pushed.

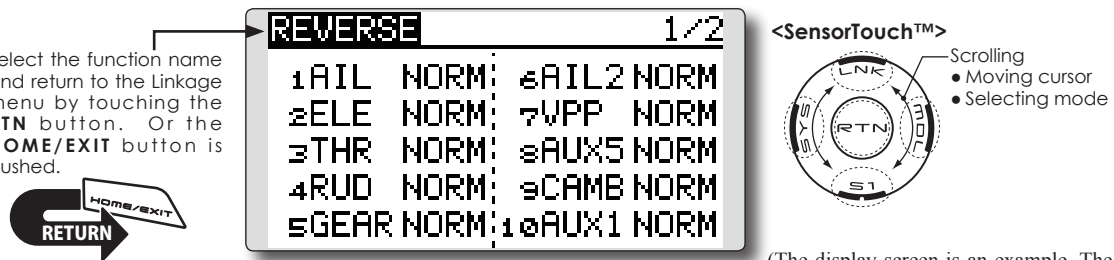

The diagram shows a screen titled "REVERSE" with a page indicator "1/2". The screen displays a list of servo channels and their current status:

1 AIL NORM	6 AIL2 NORM
2 ELE NORM	7 VPP NORM
3 THR NORM	8 AUX5 NORM
4 RUD NORM	9 CAMB NORM
5 GEAR NORM	10 AUX1 NORM

Below the screen is a circular "SensorTouch™" control pad. It has a central "RTN" button and an outer ring with buttons labeled "LNK", "S1", "S2", "S3", "S4", "S5", "S6", "S7", "S8", "S9", "S10". A legend indicates: "Scrolling" (indicated by a curved arrow), "Moving cursor" (indicated by a dot), and "Selecting mode" (indicated by a solid circle).

(The display screen is an example. The screen depends on the model type.)

### Servo reversing procedure

- \*Upon setup completion of a new model, check whether or not each servo is connected to the correct channel.
  - \*Next, determine whether you need to reverse any channels by moving each stick and/or other control inputs.
1. Move the cursor to the channel you want to reverse and touch the RTN button to switch to the data input mode.
  2. Select the direction by scrolling the touch sensor. A confirmation message appears.

[NORM]: Normal

[REV]: Reverse

3. Touch the RTN button to change the direction. (To terminate input and return to the original state, touch the S1 button.)

\*Repeat the operation above for each channel that must be reversed.

## FAIL SAFE

Sets the servos operating position when transmitter signals can no longer be received or when the receiver battery voltage drops.

The Failsafe function may be used to set up positions that the servos move to in the case of radio interference.

You may set either of two positions for each channel: Hold, where the servo maintains its last commanded position, or Failsafe, where each servo moves to a predetermined position. You may choose either mode for each channel. (**FASST 7CH mode: CH3 only**)

The T14SG system also provides you with an advanced battery monitoring function that warns you when the receiver battery has only a little power remaining. In this case, each servo is moved to the defined failsafe position. (**FASST 7CH mode: CH3 only**) The battery failsafe may be released by operating a predefined control on the transmitter (default is throttle), do not continue to fly, land as soon as possible. Remember, if the

predefined control suddenly moves to a position you did not command, land at once and check your receiver battery.

Defines servo position when signals are lost and when receiver battery voltage becomes low.

### Warning

For safety, always set the fail safe functions.

- Remember to set the throttle channel fail safe function so that the servo moves to the maximum slow side for airplanes and to the slow side from the hovering position for helicopters. Crashing of the model at full high when normal radio waves cannot be received due to interference, etc., is very dangerous.
- If the battery fail safe is reset by the throttle stick, it may be mistaken for an engine malfunction and will be reset at throttle slow and the model will continue to fly. If you have any doubts, immediately land.

- Select [FAIL SAFE] in the Linkage menu and access the setup screen shown below by touching the RTN button.

- Select the function name and return to the Linkage menu by touching the RTN button. Or the HOME/EXIT button is pushed.



FAIL SAFE		1/4	
	F/S	B.F/S	POS
1 AIL	HOLD	OFF	
2 ELE	HOLD	OFF	
3 THR	HOLD	OFF	
4 RUD	HOLD	OFF	

(The display screen is an example. The screen depends on the model type.)

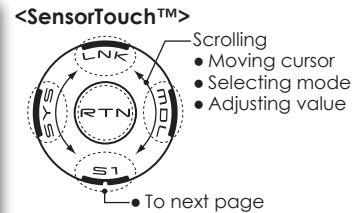

### Fail safe setting procedure

- Move the cursor to the "F/S" item of the channel you want to set and touch the RTN button to switch to the data input mode.
- Select the F/S mode by scrolling the touch sensor. A confirmation message appears.
  - \*The display blinks.
- Touch the RTN button. (Touch the S1 button to stop setting.)
  - \*The channel switches to the F/S mode.
- Move the cursor to the "POS" item.
 

Hold the corresponding stick, knob, slider, etc. in the position you want the servo to move to when the fail safe function is activated and Touch the RTN button for one second.

  - \*The set position is displayed in percentage.
  - \*If you want to return that channel to the hold mode, move the cursor to the "F/S" item and touch the RTN button to switch to the data input mode. Select the F/S mode by scrolling the touch sensor. A confirmation message appears and then change the mode by touching the RTN button.

### Battery fail safe setting procedure

- Battery fail safe can be set for each channel by the same method as the fail safe setting procedure. Select and set the "B.F/S" item.
- [ON]: Battery fail safe function ON  
[OFF]: Battery fail safe function OFF

### Battery fail safe release switch setting

- This function temporarily releases the battery fail safe function, so the fuselage can recover after the battery fail safe function was activated by a drop in the receiver battery voltage. This setting selects the switch which releases the battery fail safe function.
- Move the cursor to the [RELEASE B.F/S] item in the setup screen (last page).
  - Touch the RTN button.
    - \*The switch selection screen is called.
    - \*For a detailed description of the switch selection and ON/OFF direction setting method, see [Switch Setting Method] at the back of this manual.