

SYSTEM MENU

The System Menu sets up functions of the transmitter: This does not set up any model data.

- Select [SYSTEM] at the home screen and call the system menu shown below by touching the RTN button.
- Scrolling the touch sensor to select the function you want to set and call the setup screen by touching the RTN button.

- Select the function name and return to the System menu by touching the RTN button or pushing the Home/Exit button.

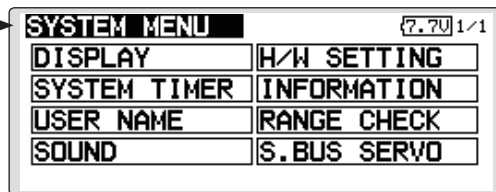

<SensorTouch™>

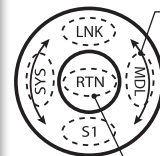

- Scrolling
- Moving cursor

• Access setup screen

System Menu functions table

[DISPLAY]: LCD contrast and back light adjustment.

[SYSTEM TIMER]: Resets the accumulated timer for each model.

[USER NAME]: User name registration.

[SOUND]: Various volume control and low battery setting.

[H/W SETTING]: H/W reverse, stick mode, stick calibration, and switch position.

[INFORMATION]: Displays the program version, SD card information, and language selection.

[RANGE CHECK]: A transmitting output is lowered and the check before a flight is carried out.

[S.BUS SERVO]: S.BUS servo setting.

DISPLAY

LCD contrast adjustment and automatic key lock

The following LCD screen adjustments and auto power off setting are possible:

- Backlighting brightness adjustment
- Backlighting off timer adjustment
- Automatic key lock setup

- Select [DISPLAY] at the system menu and call the setup screen shown below by touching the RTN button.

- Select the function name and return to the System menu by touching the RTN button or pushing the Home/Exit button.

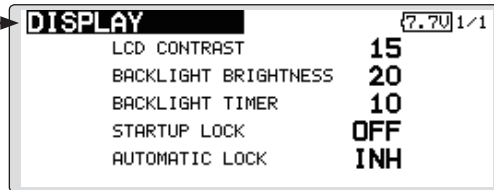

<SensorTouch™>

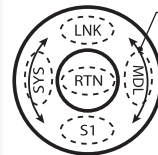

Scrolling

- Moving cursor
- Selecting mode
- Adjusting value

LCD contrast adjustment

1. Scrolling the touch sensor to select "LCD CONTRAST" and touch the RTN button to switch to the data input mode and adjust the contrast by turning the touch sensor to the left and right.

Setting range: (Lighter) 0 to 30 (Darker)

Initial value: 15

Touch the RTN button to end adjustment and return to the cursor move mode.

- *Adjust to the contrast while watching the screen display.
- *When you want to reset the contrast to the initial state, select "LCD CONTRAST" and touch the RTN button for 1 second.

Backlight brightness adjustment

1. Scrolling the touch sensor to select "BACKLIGHT BRIGHTNESS" and touch the RTN button to switch to the data input mode and adjust the contrast by turning the touch sensor to the left and right.

Setting range: (Darker) 0 to 30 (Lighter)

Initial value: 10

Touch the RTN button to end adjustment and return to the cursor move mode.

- *Adjust to the brightness while watching the screen display.
- *When you want to reset the contrast to the initial state, select "BACKLIGHT BRIGHTNESS" and touch the RTN button for 1 second.

Back-light off-timer

1. Select "Back-light timer" and touch the RTN button to switch to the data input mode and adjust the back-light off-timer by scrolling the touch sensor.

"OFF TIMER": Adjust the time when the back-

light turns off after operating the touch sensor.

Setting range: 10 to 240 sec (each 10 sec), OFF (always on)

Initial value: 10 sec

*When you want to reset the value to the initial state, touch the RTN button for one second.

2. Touch the RTN button to end adjustment and return to the cursor mode.

*If the back light is on for a long time, consumption current will increase.

Start lock

Auto Lock functions automatically when the model changes or power is turned on.

*To temporarily allow access to the T18SZ programming press and hold the S1 button for one second. Please note, the Auto Lock function timer will resume immediately once again.

1. Select "STARTUP LOCK" and touch the RTN button to switch to the data input mode and adjust the ON or OFF by scrolling the touch sensor.

Setting range: ON or OFF

Initial value: OFF

Automatic lock

Auto Lock functions automatically when there is no operation from the HOME screen display for a chosen number of seconds.

1. Scrolling the touch sensor to select "AUTOMATIC LOCK" and touch the RTN button to switch to the data input mode and adjust the time by turning the touch sensor to the left and right.

Setting range: INH, 0 to 120 (s)

Initial value: INH

SYSTEM TIMER

Resets the accumulated timer.

This function resets the system timer displayed on the home screen.

- T18SZ has two type system timers.

TOTAL timer: Displays the total accumulated time on the transmitter from the last time the timer was reset.

MODEL timer: Displays the total accumulated time on each model from the last time the timer was reset.

- System timer displayed on the home screen can be selected.

- Select [SYSTEM TIMER] at the system menu and call the setup screen shown below by touching the RTN button.



Timer selection

1. Move the cursor to the [MODE] item and touch the RTN button to switch to the data input mode.

Select the mode by scrolling the touch sensor and touch the RTN button.

TOTAL: Displays the total timer on the home screen.

MODEL timer: Displays the model timer on the home screen.

Timer reset

1. Move the cursor to the [SYSTEM TIMER] item and reset the timer to "00:00:00" by touching the RTN button for 1 second. After reset, the timer restarts from "00:00:00".

USER NAME

User name registration

This function registers the T18SZ user name.

*A name of up to 12 characters can be entered as the user name. (Space is also counted as 1 character.)

- Select [USER NAME] at the system menu and call the setup screen shown below by touching the RTN button.

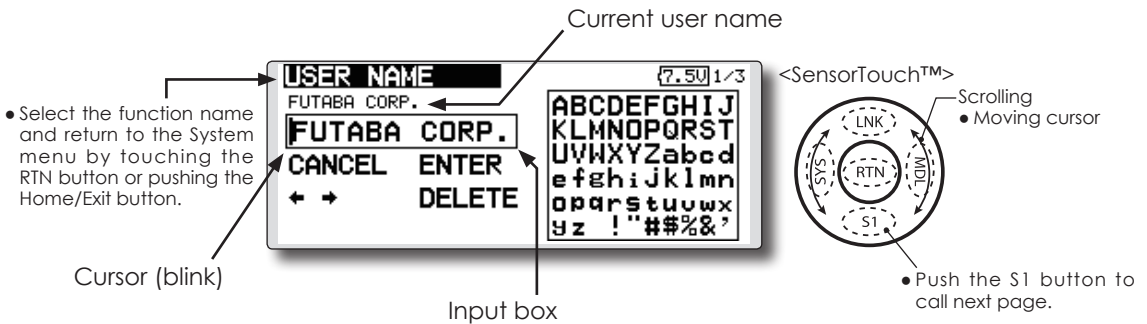

User name registration

1. Change the user name as described below:

[Moving cursor in input box]

Select [←] or [→], and touch the RTN button.

[Deleting a character]

When [DELETE] is selected and the RTN button is touched, the character immediately after the cursor is deleted.

[Adding a character]

When a candidate character is selected from the character list and the RTN button is touched, that character is added at the position immediately after the cursor.

*A name of up to 12 characters long can be entered as the user name. (A space is also counted as 1 character.)

2. At the end of input, select [ENTER] and touch the RTN button. (To terminate input and return to the original state, select [CANCEL] and touch the RTN button.)

(Character list 1/3)

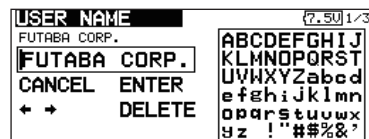

(Character list 2/3)

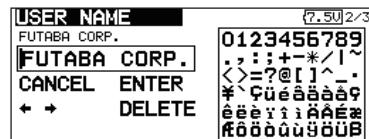

(Character list 3/3)



SOUND

Turns off the buzzer.

3 independent sound volumes: "WARNING", "VOICE" and others, are available.

"LOW BATTERY" adjusts low battery alarm voltage to match a battery.

- Select [SOUND] at the system menu and access the setup screen shown below by touching the RTN button.

- Select the function name and return to the System menu by touching the RTN button or pushing the Home/Exit button.

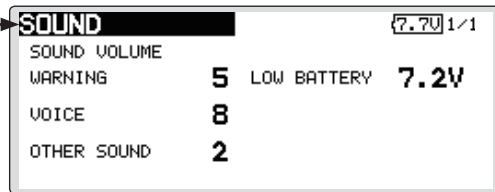

<SensorTouch™>

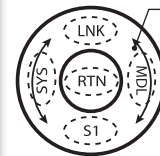

- Scrolling
- Moving cursor
- Adjusting value

- LOW BATTERY : 6.8V~7.6V

Sound volume operation

1. Move the cursor to the [WARNING][VOICE] or [OTHER SOUND] item and touch the RTN button to switch to the data input mode.
2. Select the volume by scrolling the touch sensor.
*The display blinks.
3. Touch the RTN button.

Low battery voltage operation

1. Move the cursor to the [LOW BATTERY] item and touch the RTN button to voltage to the data input mode.
2. Select the voltage by scrolling the touch sensor. (6.8V-7.6V)
*The display blinks.
3. Touch the RTN button.

H/W SETTING

Hardware reverse and stick mode, stick calibration, switch position

H/W reverse

This function reverses the operation signal of the sticks, switches, trimmer levers, and knobs.

Note: This setting reverses the actual operation signal, but does not change the display of the indicators on the display. Use the Normal mode as long as there is no special reason to use the Reverse mode.

Stick mode

This function changes the stick mode of transmitter.

Note: This will not change the throttle ratchet, etc. Those are mechanical changes that must be done by a Futaba service center.

Note: After changing the mode, it is applied when setting a new model. It is not applied to an existing model.

Stick calibration

J1-J4 stick correction can be performed.

Note: It does not carry out, when there is no necessity.

Switch

It inputs, when the kind of switch is changed or it adds.

- Select [H/W SETTING] at the system menu and call the setup screen shown below by touching the RTN button.

- Select the function name and return to the System menu by touching the RTN button or pushing the Home/Exit button.

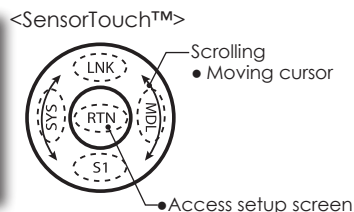
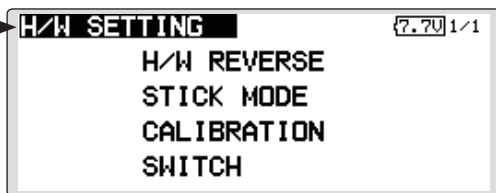

Operation direction reversal method

1. Select [H/W REVERSE] and call the setup screen shown below by touching the RTN button.

H/W REVERSE						(7.50) 1/2
H/W	MODE	H/W	MODE	H/W	MODE	
J1	NORM	SA	NORM	SE	NORM	
J2	NORM	SB	NORM	SF	NORM	
J3	NORM	SC	NORM	SG	NORM	
J4	NORM	SD	NORM	SH	NORM	

2. Use the touch sensor to move the cursor to the "MODE" item corresponding to the H/W (hardware) you want to reverse and touch the RTN button to switch to the data input mode.
3. Change the mode by turning the touch sensor to the left or right. The display blinks. When the RTN button is touched, the operation direction is reversed. (To terminate mode change, turn the touch sensor or push the S1 button.)

"NORM": Normal operation direction

"REV" : Operation direction is reversed.

Operation direction reversal method

1. Select [STICK MODE] and call the setup screen shown below by touching the RTN button.

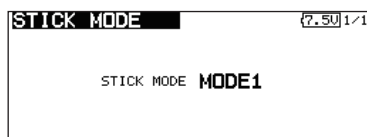

2. Use the touch sensor to move the cursor to the "STICK MODE" item and touch the RTN button to switch to the data input mode.
3. Change the mode by turning the touch sensor to the left or right. The display blinks. When the RTN button is touched, the stick mode is changed. (To terminate mode change, turn the touch sensor or push the S1 button.)



Mode	J1	J2	J3	J4
1	Aileron	Throttle	Elevator	Rudder
2	Aileron	Elevator	Throttle	Rudder
3	Rudder	Throttle	Elevator	Aileron
4	Rudder	Elevator	Throttle	Aileron

Stick calibration method

*J3 and J4 correction is described below. J1 and J2 corrections are performed using the same procedure.

1. Select [CALIBRATION] and access the setup screen shown below by touching the RTN button.

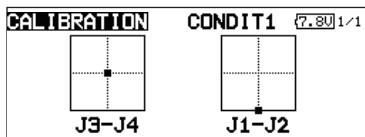

2. Move the cursor to the J3-J4 button and touch the RTN button.

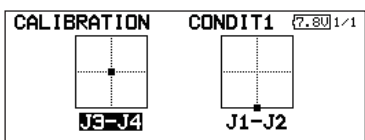

3. Move the J3 or J4 sticks to the neutral position and press the RTN button for one second.

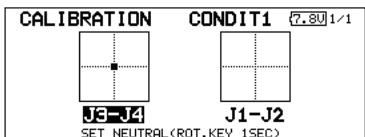

4. Set the J3 and J4 sticks fully to the bottom right and wait until the buzzer sounds.

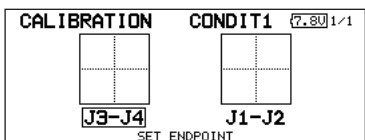

5. Set the J3 and J4 sticks fully to the top left and wait until the buzzer sounds.

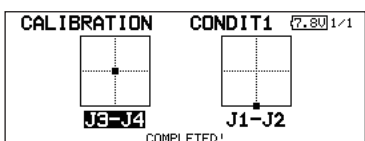

6. The above completes the correction operation. Operate and check if stick correction was performed normally.

Operation switch setting method

1. Select [SWITCH] and call the setup screen shown below by touching the RTN button.

SWITCH				7.60 1/1	
H/W	SETTING	H/W	SETTING	H/W	SETTING
SA	3Pos	SE	2Pos	SI	2Pos
SB	3Pos	SF	3Pos	SJ	2Pos
SC	3Pos	SG	3Pos		
SD	3Pos	SH	3Pos		

2. Use the touch sensor to move the cursor to the "SA-SJ" item corresponding to the switch you want to change and touch the RTN button to switch to the data input mode.
3. Change the "2Pos" or "3Pos" by turning the touch sensor to the left or right. The display blinks. It will decide, if the RTN button is pushed. (To terminate mode change, turn the touch sensor or push the S1 button.)

"3Pos": 3 position switch

"2Pos" : 2 position switch

INFORMATION

Displays the program version, SD card information, and product ID.

The T18SZ system program version information, SD card information (maximum and vacant number of model data), and product ID are displayed on the Information screen.

*When the SD card is not inserted, the SD card information is not displayed.

The language displayed in home, menu, and setup screen is selectable.

Moreover, the unit of a telemetry display can also be changed.

- Select [INFORMATION] at the system menu and call the setup screen shown below by touching the RTN button.

- Select the function name and return to the System menu by touching the RTN button or pushing the Home/Exit button.

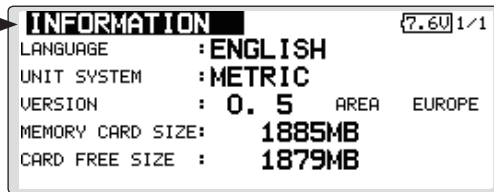

<SensorTouch™>

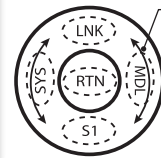

- Scrolling
- Moving cursor
- Selecting mode

Information

"VERSION": T18SZ system program version information

"MEMORY CARD SIZE": Maximum number of model data (SD card)

"CARD FREE SIZE": Vacant number of model data (SD card)

Language selection

1. Use the touch sensor to move the cursor to the "LANGUAGE" item and touch the RTN button to switch to the data input mode.
2. Change the language by turning the touch sensor to the left or right. The display blinks. When the RTN button is touched, the language is changed. (To terminate mode change, turn the touch sensor or push the S1 button.)

Unit system selection

1. Use the touch sensor to move the cursor to the "UNIT SYSTEM" item and touch the RTN button to switch to the data input mode.
2. Change the unit by turning the touch sensor to the left or right. The display blinks. When the RTN button is touched, the unit is changed. (To terminate mode change, turn the touch sensor or push the S1 button.)

RANGE CHECK

Before a flight ground range check.

The 'range check mode' reduces the transmission range of the radio waves to allow for a ground range check.

*The range check mode, when activated, will continue for 90 seconds unless the user exits this mode early. When the progress bar reaches 90 second mark, the RF transmission automatically returns to the normal operating power.

⚠ WARNING

Do not fly in the range check mode.

■ Since the range of the radio waves is short, if the model is too far from the transmitter, control will be lost and the model will crash.

- Pushing [U.menu/Mon]key is continued. → Turn ON the transmitter's power switch. (First, a throttle stick is made into a low position, and turns on a power supply.) It is displayed as "TRANSMIT?". "NO" is chosen and [RTN] is pushed.
- Select [RANGE CHECK] at the system menu and call the setup screen shown below by touching the RTN button.

- Select the function name and return to the System menu by touching the RTN button or pushing the Home/Exit button.

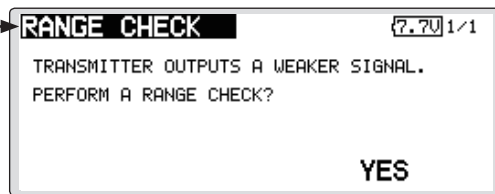

<SensorTouch™>

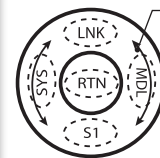

Scrolling
• Moving cursor

- [Yes] is chosen and [RTN] is pushed.

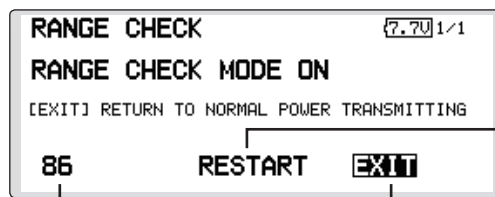

- Range Check mode timer is returned to 90

- Remaining time of RANGE CHECK MODE

- Range Check mode is disabled

Rotation Range Check method

1. Pushing [U.menu/Mon]key is continued. → Turn ON the transmitter's power switch. (First, a throttle stick is made into a low position, and turns on a power supply.) It is displayed as "TRANSMIT?." "NO" is chosen and [RTN] is pushed.
*For safety, the RANGE CHECK mode can not be selected while the RF transmission is active.
2. In the system menu, choose the 'Range Check' selection from the menu options.
3. The Range Check screen is displayed. To activate the Range Check mode press the [Yes] button. During the Range Check period, the RF power is reduced to allow the ground range tests to be performed.
4. The Range Check function automatically exits after the 90 second time limit has

expired. The count down time is displayed on the transmitter's screen. Should you complete the range check before the 90 seconds has pressed, press the [Exit] button.

*When the [RESTART] button is pressed, the range check mode timer is returned to 90.

*Please note, upon expiration of the 90 seconds, or when [Exit] is selected, the transmitter will automatically return to the normal RF operation as noted on the display.

*Once the T18SZ is transmitting at full power, it is not possible to enter the Range Check mode without first switching the transmitter Off and back On. This has been designed to prevent a modeler from inadvertently flying in the Range Check mode.

5. When the [Exit] button is pressed, the Range Check mode is disabled and the T18SZ will begin transmitting at full power.

*After exiting the Range Check mode, the function cannot be selected again. To select the Range Check mode again you must cycle the transmitter power switch.

S.BUS Servo

S.BUS/S.BUS2 servo setting

An S.BUS/S.BUS2 servo can memorize the channel and various settings itself. Servo setting can be performed on the T18SZ screen by wiring the servo as shown in the figure.

• Servo ID number

Individual ID numbers are memorized for your S.BUS servos in your T18SZ. When a servo is used (as shown at the right), the servo ID number is automatically read by the transmitter.

If you use multiple S.BUS servos and do not want to change the settings on all that are mounted in a fuselage, only the desired servo in the group can be set by entering the ID of that specific servo.

* With S.BUS/S.BUS2 servos of use, there are a function which can be used, and an impossible function and a display screen changes.

(Only the function which can be used by a servo is displayed.)

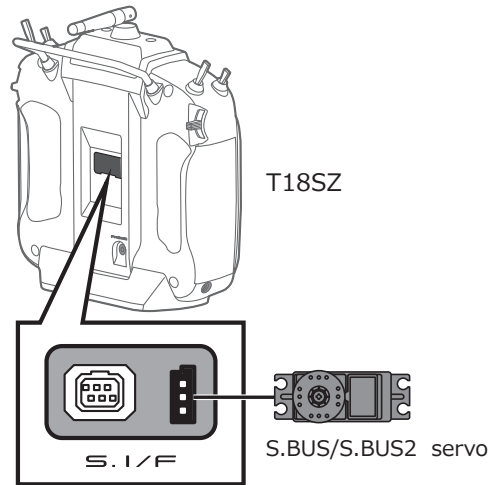

* After reading completion, with connection of the above figure, if a stick is moved, the test of operation of the servo can be operated and carried out.

*It is not necessary to carry out multiple connection of the battery like a T18MZ/T14SG.

(It will damage, if it connects.)

*When you connect to a transmitter many servos which consume many current, please use "Another power supply HUB". And electric power is supplied to a servo with another power supply.

- Call the following setting screen by pressing the [S.BUS Servo] button in the System Menu.

- Select the function name and return to the System menu by touching the RTN button or pushing the Home/Exit button.

<SensorTouch™>

- Push the S1 button to call next page.

Procedure for changing S.BUS/S.BUS2 servo setting

1. Select [S.BUS Servo] of the System Menu.
2. Wire the servo as shown in the figure above.
3. Press [READ]. The ID and current setting of that servo are displayed.
4. When multiple servos are connected change [INH] at the right side of the ID number on the screen to [ACT] and enter the ID of the servo you want to set.
5. Set each item. (Please see the next page.)
6. Press [WRITE]. The settings are changed.

S.BUS Servo Description of function of each parameter

*There are a function which can be used according to the kind of servo, and an impossible function.

- **ID**

Displays the ID of the servo whose parameters are to be read. It cannot be changed.

- **Channel**

Channel of the S.BUS system assigned to the servo. Always assign a channel before use.

- **Reverse**

The direction in which the servo rotates can be changed.

- **Servo type**

When "Retractable" is selected and the servo has been continuously stopped for 30 seconds, the dead band expands and unnecessary hold current due to external force is eliminated. When a new control signal enters, normal operation is resumed. When using the servo as a landing gear servo, select "Retractable". Also adjust the servo travel to match the landing gear movement range.

- **Soft Start**

Restricts operation in the specified direction the instant the power is turned on. By using this setting, the first initial movement when the power is turned on slowly moves the servo to the specified position.

- **Stop Mode**

The state of the servo when the servo input signal is lost can be specified. The "Hold" mode setting holds the servo in its last commanded position even if using AM or FM system.

- **Smoother**

This function changes smoothness of the servo operation relative to stick movement changes. Smooth setting is used for normal flight. Select the "OFF" mode when quick operation is necessary such as 3D.

- **Neutral Offset**

The neutral position can be changed. When the neutral offset is large value, the servo's range of travel is restricted on one side.

- **Speed Control**

Speeds can be matched by specifying the operating speed. The speed of multiple servos can be matched without being affected by motor fluctuations. This is effective for load torques below the maximum torque.

However, note that the maximum speed will not be exceed what the servo is capable of even if the servos operating voltage is increased.

- **Dead band**

The dead band angle at stopping can be specified.

[Relationship between dead band set value and servo operation]

Small → Dead band angle is small and the servo is immediately operated by a small signal change.

Large → Dead band angle is large and the servo does not operate at small signal changes.

(Note) If the dead band angle is too small, the servo will operate continuously and the current consumption will increase and the life of the servo will be shortened.

- **Travel Adjust**

The left and right travels centered about the neutral position can be set independently.

- **Boost**

The minimum current applied to the internal motor when starting the servo can be set. Since a small travel does not start the motor, it essentially feels like the dead band was expanded. The motor can be immediately started by adjusting the minimum current which can start the motor.

[Relationship between boost set value and servo operation]

Small → Motor reacts to a minute current and operation becomes smooth.

Large → Initial response improves and output torque increases. However, if the torque is too large, operation will become rough.

• Boost ON/OFF

OFF : It is the boost ON at the time of low-speed operation.(In the case of usual)

ON : It is always the boost ON.(When quick operation is hope)

• Damper

The characteristic when the servo is stopped can be set.

When smaller than the standard value, the characteristic becomes an overshoot characteristic. If the value is larger than the standard value, the brake is applied before the stop position.

Especially, when a large load is applied, overshoot, etc. are suppressed by inertia and hunting may occur, depending on the conditions. If hunting (phenomena which cause the servo to oscillate) occurs even though the Dead Band, Stretcher, Boost and other parameters are suitable, adjust this parameter to a value larger than the initial value.

[Relationship between damper set value and servo operation]

Small → When you want to overshoot. Set so that hunting does not occur.

Large → When you want to operate so that braking is not applied. However, it will feel like the servo response has worsened.

(Note) If used in the hunting state, not only will the current consumption increase, but the life of the servo will also be shortened.

• Stretcher

The servo hold characteristic can be set. The torque which attempts to return the servo to the target position when the current servo position has deviated from the target position can be adjusted.

This is used when stopping hunting, etc., but the holding characteristic changes as shown below.

[Relationship between stretcher and servo operation]

Small → Servo holding force becomes weaker.

Large → Servo holding force becomes stronger.

(Note) When this parameter is large, the current consumption increases.

• Buzzer

When the power supply of a servo is previously turned on at the time of a power supply injection without taking transmit of a transmitter, the buzzer sound of about 2.5 Hz continues sounding from a servo.

(Even when the transmit of a transmitter is taken out previously, a buzzer becomes until the signal of a servo is outputted normally, but it is not unusual.)

The transmitter has been turned OFF ahead of a servo power supply → The buzzer sound of about 1.25 Hz continues sounding as servo power supply end failure alarm.

(Do not insert or remove the servo connector while the receiver power is ON. A buzzer may sound by incorrect recognition.)

* Buzzer sound is generated by vibrating the motor of a servo.

Since current is consumed and a servo generates heat, please do not operate the number more than needed or do not continue sounding a buzzer for a long time.

MODEL BASIC SETTING PROCEDURE

Airplane/glider basic setting procedure

1. Model addition and call

Initial setting assigns 1 model to the T18SZ transmitter. The Model Select function of the Linkage Menu is used to add models and to select models which are already set.

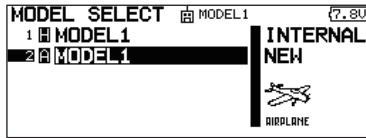

The data for up to 30 models can be saved to the transmitter. Data can also be saved to the optional SD card.

The currently selected model name is displayed at the top of the screen. Before flying and before changing any settings, always confirm the model name.

When a new model is added, the Model type select screen and System/Receiver ID setup screen automatically appear. Please be aware that the transmitter will stop transmitting when you change the model.

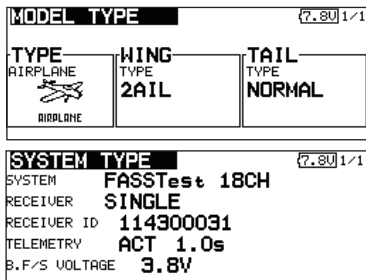

2. Model type selection

Select the model type matched to the aircraft with the Model Type select function of the Linkage Menu. For an airplane, select the model type from among the 2 types: airplane and glider. After the wing type is selected the tail type select screen is displayed. Select the tail type matched to the aircraft.

There are 13 wing types and 3 tail types for airplane and glider.

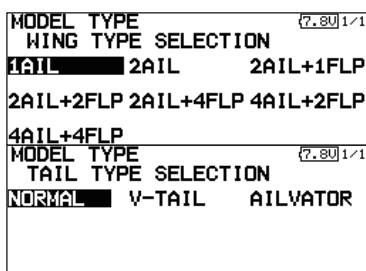

3. Fuselage linkage

Connect the ailerons, elevators, throttle, rudder, etc. in accordance with the model's instruction manual. For a description of the connection method, see the Receiver and Servos Connection.

Note: The channel assignment of the T18SZ is different from that of our existing systems. Note that even for the same "airplane model", when the wing type and tail type are different, the channel assignment may be different. (The channel assigned to each function can be checked at the Function menu of the Linkage Menu.)

CH	FUNCTION	CONTROL	TRIM
1	AILERON	J1	T1 COMB.
2	ELEVATOR	J3	T3 COMB.
3	THROTTLE	J2	T2 COMB.
4	RUDDER	J4	T4 COMB.

- If the direction of the servo is incorrect, adjust the direction with the Reverse function of the Linkage Menu.

CH	FUNCTION	MODE	CH	FUNCTION	MODE
1	AILERON	NORM	5	GEAR	NORM
2	ELEVATOR	NORM	6	AILERON2	NORM
3	THROTTLE	NORM	7	AUXILIARY5	NORM
4	RUDDER	NORM	8	AUXILIARY4	NORM

- Adjust the neutral position and control surface angle with the linkage, and fine tune them with the Sub Trim and End Point functions (angle adjustment). To protect the linkage, a limit position can also be set with the End Point function. The End Point function can adjust the amount of up/down and left/right movement, limit, and servo speed of each channel.

CH	FUNCTION	MODE	CH	FUNCTION	MODE
1	AILERON	+0	5	GEAR	+0
2	ELEVATOR	+0	6	AILERON2	+0
3	THROTTLE	+0	7	AUXILIARY5	+0
4	RUDDER	+0	8	AUXILIARY4	+0

CH	FUNCTION	LIMIT	TRAV.	TRAV.	LIMIT	SPEED
1	AILERON	135%	100%	100%	135%	0
2	ELEVATOR	135%	100%	100%	135%	0
3	THROTTLE	135%	100%	100%	135%	0
4	RUDDER	135%	100%	100%	135%	0

4. Throttle cut setting

Throttle cut can be performed with one touch by a switch without changing the throttle trim position.

Set throttle cut with the Throttle Cut function of the Linkage Menu. After activating the throttle cut function and selecting the switch, adjust the throttle position so that the carburetor becomes fully closed. For safety, the

throttle cut function operates the throttle stick in the 1/3 or less (slow side) position.

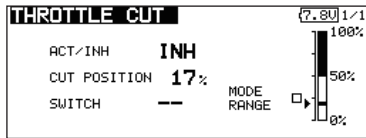

5. Idle down setting

The idling speed can be lowered with one touch by a switch without changing the throttle trim position. Perform this setting with the Idle Down function of the Linkage Menu. After activating the Idle Down function and selecting the switch, adjust the idle Down speed. For safety, the idle down function acts only when the throttle stick is slow side.

*While the Throttle Cut function is in operation, the Idle Down function does not work.

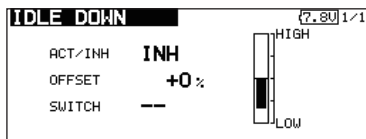

6. AFR (D/R)

AFR function is used to adjust the throw and operation curve of the stick, lever, and switch functions for each flight condition. This is normally used after End Point has defined the maximum throw directions.

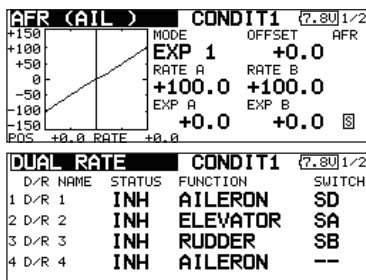

7. Airbrake

This function is used when an air brake is necessary when taking off or diving, etc.

The preset elevators and flaps (camber flap, brake flap) offset amount can be activated by a switch.

The offset amount of the aileron, elevator, and flap servos can be adjusted as needed. Also the speed of the aileron, elevator, and flap servos can be adjusted. (IN side/OUT side) A delay can be set for each condition, and a Cut switch which will turn OFF the delay can be

chosen. Trim amounts can be fine-tuned by setting a VR. You can also set the Auto Mode, which will link Airbrake to a stick, switch, or dial. A separate stick switch or dial can also be set as the ON/OFF switch.

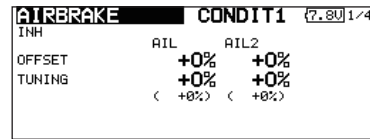

8. Addition of flight conditions

The Condition Select function automatically allocates the Condition 1 (CONDIT1) for each model. Condition 1 is the default condition and is the only one active when a new model type is defined.

If you want to add flight conditions, please refer to a description of the COND. SELECT function.

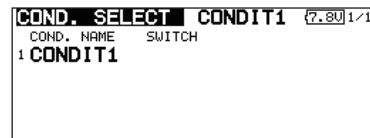

*The Condition 1 is always on, and remains on until other conditions are activated by switches.

*When a new condition is added, the model data of the Condition 1 is automatically copied to the new condition.

*You can set the model data of new condition in the switch ON state. However, if the group mode (GROUP) was selected in advance, the same data will be input at all the conditions. Select the single mode (SINGLE) and adjust only the condition you want to change. For Group/Single mode switching, refer to the description at the back of this manual.

*The Condition Delay can be programmed for each channel. The Condition Delay is used to change the servo throw smoothly when switching conditions.

9. When tailless wing model selected

Tailless wing elevator operation uses elevator to camber mixing. This function cannot be performed at initial setting.

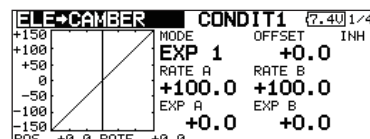

Helicopter basic setting procedure

This section outlines examples of use of the helicopter functions of the T18SZ. Adjust the actual values, etc. to match the fuselage used.

1. Model addition and call

Default setting assigns 1 model to the T18SZ. To add new models or to call a model already set, use the Model Select function of the Linkage Menu.

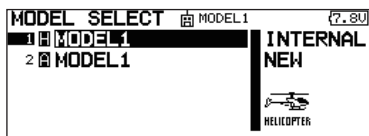

This is convenient when calling a model after registering the model names in advance. (The data of up to 30 models can be saved at the transmitter. Data can also be saved to the optional SD card.)

The currently called model is displayed at the top of the screen. Before flying and before changing any settings, always confirm the model name.

When a new model is added, the Model Type Select screen and Frequency/Modulation mode/Receiver ID setup screen automatically appear. Change, or check that they match the type, frequency, and receiver type of the model used.

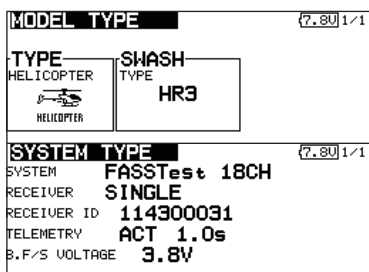

2. Model type and swash type selection

If a different model type is already selected, select helicopter with the Model Type function of the Linkage Menu, and then select the swash type matched to the helicopter.

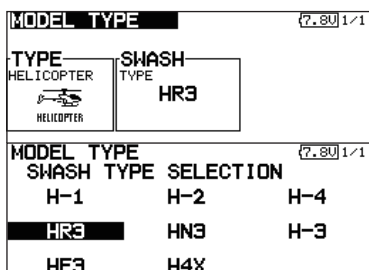

*The Model Type function automatically selects the appropriate output channels, control functions, and mixing functions for the chosen model type. Eight swash types are available for helicopters.

*For a description of the swash type selection, refer to the MODEL TYPE function.

3. Flight condition addition

The transmitter can install up to eight flight conditions per model.

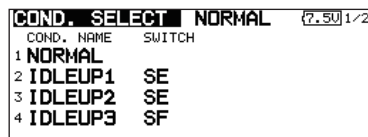

The Condition Select function automatically allocates five conditions for helicopter.

(Initial setting)

- NORMAL
- IDLE UP1 (SW-E)
- IDLE UP2 (SW-E)
- IDLE UP3 (SW-F)
- HOLD (SW-G)

Note: Since you may accidentally activate the conditions that has not been setup during flight and this could cause a crash, delete the conditions not used.

*For a description of the condition deletion, refer to the COND. SELECT function.

The NORMAL condition is always on, and remains on until other conditions are activated by switches.

The priority is throttle hold/idle up 2/idle up 1/normal. Throttle hold has the highest priority.

Add other conditions, as required.

The Condition Delay can be programmed for each channel. The Condition Delay is used to change the servo throw smoothly when switching conditions.

(General flight condition setting example)

- Normal: (Use initial setting conditions/operate when switch OFF)
Use from engine starting to hovering.
- Idle up 1: (Operate at SW-E center)
Use in 540° stall turn, loop, rolling stall turn, and other maneuvers.
- Idle up 2: (Operate at SW-E forward side)
Use in rolls.
- Throttle hold: (Operate at SW-G forward side)
Use in auto rotation.

4. Fuselage linkage

Connect the throttle rudder, aileron, elevator, pitch, and other servos in accordance with the kit instruction manual. For a description of the connection method, see "Receiver and Servos Connection".

Note: The channel assignment of the T18SZ is different from that of our existing systems. (The channel assigned to each function can be checked at the Function menu of the Linkage Menu.)

FUNCTION		NORMAL		(7.8U) 1/3
CH	FUNCTION	CONTROL	---	TRIM ---
1	AILERON	J1	T1	SEPAR
2	ELEVATOR	J3	T3	SEPAR
3	THROTTLE	J2	T2	SEPAR
4	RUDDER	J4	T4	SEPAR

- If the direction of operation of the servo is incorrect, use the Reverse function of the Linkage Menu. Also use the swash AFR function in other than the H-1 mode.

SERVO REVERSE		(7.8U) 1/3			
CH	FUNCTION	MODE	CH	FUNCTION	MODE
1	AILERON	NORM	5	GYRO<RUD>	NORM
2	ELEVATOR	NORM	6	PITCH	NORM
3	THROTTLE	NORM	7	GOVERNOR	NORM
4	RUDDER	NORM	8	GOVERNOR2	NORM

SWASH		(7.8U) 1/3	
NEUTRAL POINT	100%	SWASH AFR	
POINT	50%	AILERON	+50%
HIGH PITCH	□	ELEVATOR	+50%
LOW PITCH	■	PITCH	+50%
	0%		

- Adjust the direction of operation of the gyro. (Gyro side function)
- Connect the throttle linkage so that the carburetor can fully close at full trim throttle cut.
- Adjust the neutral position at the linkage side and fine tune with the Sub-Trim function and End Point function (rudder angle adjustment). To protect the linkage, a limit position can also be set with the End Point function.

SUB-TRIM		(7.8U) 1/2		
CH	FUNCTION	CH	FUNCTION	
1	AILERON	+0	5 GYRO<RUD>	+0
2	ELEVATOR	+0	6 PITCH	+0
3	THROTTLE	+0	7 GOVERNOR	+0
4	RUDDER	+0	8 GOVERNOR2	+0

END POINT		(7.8U) 1/4	
CH	FUNCTION	LIMIT TRAV.	TRAV. LIMIT SPEED
1	AILERON	135% 100% 100%	135% 0
2	ELEVATOR	135% 100% 100%	135% 0
3	THROTTLE	135% 100% 100%	135% 0
4	RUDDER	135% 100% 100%	135% 0

- Swash plate correction (Except H-1 mode)
*If any interactions are noticed, for a description of the linkage correction function, please refer to the SWASH function.

5. Throttle/Pitch curve setting

This function adjusts the throttle or pitch operation curve in relation to the movement of the throttle stick for each condition.

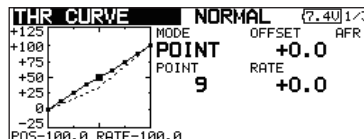

<Throttle curve setting example>

Call the throttle curve of each condition with the condition select switch.

- Normal curve adjustment**
Normal curve creates a basic throttle curve centered near hovering. This curve is adjusted together with the pitch curve (Normal) so that the engine speed is constant and up/down control is easiest.
- Idle up curve adjustment**
The low side Throttle curve creates a curve matched for aerobatics (loop, roll, 3D, etc.).
- Throttle hold curve adjustment**
The curve is not used when performing auto rotation dives.
Confirm that the rate of the slowest position (0%) of the stick is 0% (initial setting).

<Example of pitch curve setting>

Call the pitch curve of each condition with the condition select switch.

- Pitch curve (Normal)**
Make the pitch at hovering approximately +5°~6°. Set the pitch at hovering with the stick position at the 50% point as the standard.
*Stability at hovering may be connected to the throttle curve. Adjustment is easy by using the hovering throttle function and hovering pitch function together.
- Pitch curve (Idle up 1)**
The idle up 1 pitch curve function creates a curve matched to airborne flight. Set to -7°~+12° as standard.
- Pitch curve (Idle up 2)**
The high side pitch setting is less than idle up 1. The standard is +8°.
- Pitch curve (Hold)**
At auto rotation, use the maximum pitch at both the high and low sides.
[Pitch angle setting example]
Throttle hold: -7°~+12°

6. AFR (D/R)

AFR (D/R) function is used to adjust the throw and operation curve of aileron, elevator and rudder for each condition.

*For throttle and pitch curve settings, refer to the above-mentioned "Throttle/Pitch curve setting"

This is normally used after End Point has defined the maximum throw directions.

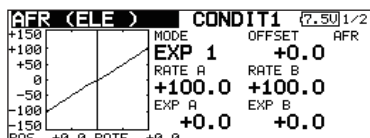

D/R NAME	STATUS	FUNCTION	SWITCH
1 D/R 1	INH	AILERON	--
2 D/R 2	INH	AILERON	--
3 D/R 3	INH	AILERON	--
4 D/R 4	INH	AILERON	--

7. Gyro sensitivity and mode switching

The gyro sensitivity and mode switching function is dedicated gyro mixing of the Model Menu, and can be set for each condition.

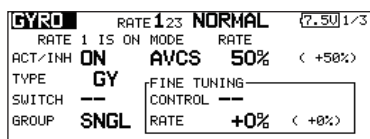

- Normal condition (hovering): Gyro sensitivity maximum
- Idle up 1/Idle up 2/Throttle hold: Gyro sensitivity minimum
- However, at auto rotation of a tail-driven helicopter, this function may not have any effect at high gyro sensitivity.

8. Pitch to RUD mixing setting

Note: When using a GY601, GY502, GY401, or other heading hold gyro, this Pitch to RUD mixing should not be used. The reaction torque is corrected at the gyro side. When operating the gyro in the AVCS mode, the mixed signal will cause neutral deviation symptoms and the gyro will not operate normally.

Use this function when you want to suppress the torque generated by the changes in the pitch and speed of the main rotor during pitch operation. Adjust it so that the nose does not swing in the rudder direction. However, when using a heading hold gyro like those shown below,

do not use Pitch to RUD mixing.

Call the Pitch to RUD mixing function from the Model Menu, and set the curve for each condition. (At initial setting, this function is in the "INH" state. To use it, set it to the "ON" state.)

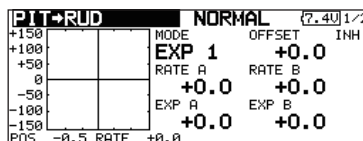

<Setting example>

Call the mixing curve of each condition with the condition select switch.

1. A curve setting example is shown below.

- Pitch to RUD mixing curve (Normal)
 - Use the hovering system and set this curve to match take off and landing and vertical climb at a constant speed.
 - *For this curve, use the initial setting [EXP1] curve type.
- Pitch to RUD mixing (Idle up 1)
 - Use this curve in 540° stall turn, loop, and rolling stall turn, and adjust it so the fuselage is facing straight ahead when heading into the wind.
 - *For this curve, [EXP1] curve type can be used and the entire curve can be lowered with the [Offset] function.
- Pitch to RUD mixing (Hold)
 - This function is set so that the fuselage is facing straight ahead at straight line auto rotation. The pitch of the tail rotor becomes nearly 0°.
 - *For this curve, [EXP1] curve type can be used and the entire curve can be lowered with the [Offset] function.

- Other settings
 - The mixing rise characteristic at pitch operation can be adjusted. An acceleration function which temporarily increases and decreases the mixing amount can be set.

9. Throttle hold setting

*If throttle hold is necessary, please refer to the THR HOLD function.

10. Throttle cut setting

Throttle cut provides an easy way to stop the engine, by flipping a switch with the throttle stick at idle. The action is not functional at high throttle to avoid accidental dead sticks. The switch's location and direction must be chosen, as it defaults to NULL.

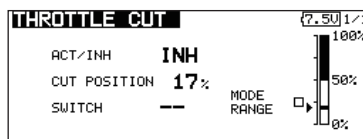

*With throttle stick at idle, adjust the cut position until the engine consistently shuts off, but throttle linkage is not binding.

11. Swash Mix corrects aileron, elevator and pitch interaction

The swash mix function is used to correct the swash plate in the aileron (Left/Right Cyclic) and elevator (Forward/Aft Cyclic) direction corresponding to each operation of each condition.

SWASH MIX		NORMAL		(7.50) 1/1
MIXING	ACT	SWITCH	TRIM	GROUP
AIL+ELE	INH	--	OFF	SINGLE
ELE+AIL	INH	--	OFF	SINGLE
PIT+AIL	INH	--		SINGLE
PIT+ELE	INH	--		SINGLE

12. Throttle mixing setting

*If throttle mixing is necessary for a compensation for slowing of engine speed caused by swash plate operation during aileron or elevator operation, please refer to the THROTTLE MIX function.

13. Other special mixings

- Pitch to Needle mixing
This mixing is used with engines with a construction which allows needle control during flight (fuel-air mixture adjustment). A needle curve can be set. The needle servo rise characteristics at throttle stick acceleration/deceleration operation can be adjusted. (Acceleration function)
- Governor mixing
This mixing is dedicated governor mixing when a governor is used. Up to 3 rates (speeds) can be switched for each condition.



Servo connection by model type

The T18SZ transmitter channels are automatically assigned for optimal combination according to the type selected with the Model Type function of the Linkage Menu. The channel assignment (initial setting) for each model type is shown below. Connect the receiver and servos to match the type used.

*The set channels can be checked at the Function screen of the Linkage Menu. The channel assignments can also be changed. For more information, read the description of the Function menu.

Airplane/glider/motor glider

●Airplane and V tail

RX CH	1AIL			2AIL			2AIL+1FLAP			2AIL+2FLAP			The output CH of each system ↓ FASSTest 18CH 5-FHSS FASSTest 12CH FASST 7CH ↓ FASST MULT
	Airplane	Glider		Airplane	Glider		Airplane	Glider		Airplane	Glider		
		EP			EP			EP			EP		
1	Aileron	Aileron	Aileron	Aileron	Aileron	Aileron	Aileron	Aileron	Aileron	Aileron	Aileron	Aileron	
2	Elevator	Elevator	Elevator	Elevator	Elevator	Elevator	Elevator	Elevator	Elevator	Elevator	Elevator	Elevator	
3	Throttle	Motor	AUX7	Throttle	Motor	AUX7	Throttle	Motor	AUX7	Throttle	Motor	AUX7	
4	Rudder	Rudder	Rudder	Rudder	Rudder	Rudder	Rudder	Rudder	Rudder	Rudder	Rudder	Rudder	
5	Gear	AUX6	AUX6	Gear	AUX6	AUX6	Gear	AUX6	AUX6	Aileron2	Aileron2	Aileron2	
6	Airbrake	Airbrake	Airbrake	Aileron2	Aileron2	Aileron2	Aileron2	Aileron2	Aileron2	Flap	Flap	Flap	
7	AUX5	AUX5	AUX5	AUX5	AUX5	AUX5	Flap	Flap	Flap	Flap2	Flap2	Flap2	
8	AUX4	AUX4	AUX4	AUX4	AUX4	AUX4	AUX5	AUX5	AUX5	Gear	AUX6	AUX6	
9	AUX3	AUX3	AUX3	AUX3	AUX3	AUX3	AUX4	AUX4	AUX4	AUX5	AUX5	AUX5	
10	AUX2	AUX2	AUX2	AUX2	AUX2	AUX2	AUX3	AUX3	AUX3	AUX4	AUX4	AUX4	
11	AUX1	AUX1	AUX1	AUX1	AUX1	AUX1	AUX2	AUX2	AUX2	AUX3	AUX3	AUX3	
12	AUX1	AUX1	AUX1	AUX1	AUX1	AUX1	AUX1	AUX1	AUX1	AUX2	AUX2	AUX2	
13	AUX1	AUX1	AUX1	AUX1	AUX1	AUX1	AUX1	AUX1	AUX1	AUX1	AUX1	AUX1	
14	AUX1	AUX1	AUX1	AUX1	AUX1	AUX1	AUX1	AUX1	AUX1	AUX1	AUX1	AUX1	
15	AUX1	AUX1	AUX1	AUX1	Butterfly	Butterfly	AUX1	Butterfly	Butterfly	AUX1	Butterfly	Butterfly	
16	AUX1	AUX1	AUX1	Camber	Camber	Camber	Camber	Camber	Camber	Camber	Camber	Camber	
DG1	SW	SW	SW	SW	SW	SW	SW	SW	SW	SW	SW	SW	
DG2	SW	SW	SW	SW	SW	SW	SW	SW	SW	SW	SW	SW	

RX CH	2AIL+4FLAP			4AIL+2FLAP			4AIL+4FLAP			The output CH of each system ↓ FASSTest 18CH 5-FHSS FASSTest 12CH FASST 7CH ↓ FASST MULT
	Airplane	Glider		Airplane	Glider		Airplane	Glider		
		EP			EP			EP		
1	Aileron	Aileron	Aileron	Aileron	Aileron	Aileron	Aileron	Aileron	Aileron	
2	Elevator	Elevator	Elevator	Elevator	Elevator	Elevator	Elevator	Elevator	Elevator	
3	Throttle	Rudder	Rudder	Throttle	Rudder	Rudder	Throttle	Rudder	Rudder	
4	Rudder	Aileron2	Aileron2	Rudder	Aileron2	Aileron2	Rudder	Aileron2	Aileron2	
5	Gear	Flap	Flap	Gear	Aileron3	Aileron3	Gear	Aileron3	Aileron3	
6	Aileron2	Flap2	Flap2	Aileron2	Aileron4	Aileron4	Aileron2	Aileron4	Aileron4	
7	Flap	Flap3	Flap3	Aileron3	Flap	Flap	Aileron3	Flap	Flap	
8	Flap2	Flap4	Flap4	Aileron4	Flap2	Flap2	Aileron4	Flap2	Flap2	
9	Flap3	Motor	AUX7	Flap	Motor	AUX7	Flap	Flap3	Flap3	
10	Flap4	AUX6	AUX6	Flap2	AUX6	AUX6	Flap2	Flap4	Flap4	
11	AUX5	AUX5	AUX5	AUX5	AUX5	AUX5	Flap3	Motor	AUX7	
12	AUX4	AUX4	AUX4	AUX4	AUX4	AUX4	Flap4	AUX6	AUX6	
13	AUX3	AUX3	AUX3	AUX3	AUX3	AUX3	AUX5	AUX5	AUX5	
14	AUX2	AUX2	AUX2	AUX2	AUX2	AUX2	AUX4	AUX4	AUX4	
15	AUX1	Butterfly	Butterfly	AUX1	Butterfly	Butterfly	AUX3	Butterfly	Butterfly	
16	Camber	Camber	Camber	Camber	Camber	Camber	Camber	Camber	Camber	
DG1	SW	SW	SW	SW	SW	SW	SW	SW	SW	
DG2	SW	SW	SW	SW	SW	SW	SW	SW	SW	

●Ailevator

RX CH	1AIL			2AIL			2AIL+1FLAP			2AIL+2FLAP			The output CH of each system FASTest 18CH FASTest 12CH 5-FHSS FASTest 7CH FAST MULT
	Airplane	Glider		Airplane	Glider		Airplane	Glider		Airplane	Glider		
		EP			EP			EP			EP		
1	Aileron	Aileron	Aileron	Aileron	Aileron	Aileron	Aileron	Aileron	Aileron	Aileron	Aileron	Aileron	
2	Elevator	Elevator	Elevator	Elevator	Elevator	Elevator	Elevator	Elevator	Elevator	Elevator	Elevator	Elevator	
3	Throttle	Motor	AUX7	Throttle	Motor	AUX7	Throttle	Motor	AUX7	Throttle	Motor	AUX7	
4	Rudder	Rudder	Rudder	Rudder	Rudder	Rudder	Rudder	Rudder	Rudder	Rudder	Rudder	Rudder	
5	Gear	AUX6	AUX6	Gear	AUX6	AUX6	Elevator2	Elevator2	Elevator2	Elevator2	Elevator2	Elevator2	
6	Airbrake	Airbrake	Airbrake	Aileron2	Aileron2	Aileron2	Aileron2	Aileron2	Aileron2	Aileron2	Aileron2	Aileron2	
7	Elevator2	Elevator2	Elevator2	Elevator2	Elevator2	Elevator2	Flap	Flap	Flap	Flap	Flap	Flap	
8	AUX5	AUX5	AUX5	AUX5	AUX5	AUX5	Gear	AUX6	AUX6	Flap2	Flap2	Flap2	
9	AUX4	AUX4	AUX4	AUX4	AUX4	AUX4	AUX5	AUX5	AUX5	Gear	AUX6	AUX6	
10	AUX3	AUX3	AUX3	AUX3	AUX3	AUX3	AUX4	AUX4	AUX4	AUX5	AUX5	AUX5	
11	AUX2	AUX2	AUX2	AUX2	AUX2	AUX2	AUX3	AUX3	AUX3	AUX4	AUX4	AUX4	
12	AUX1	AUX1	AUX1	AUX1	AUX1	AUX1	AUX2	AUX2	AUX2	AUX3	AUX3	AUX3	
13	AUX1	AUX1	AUX1	AUX1	AUX1	AUX1	AUX1	AUX1	AUX1	AUX2	AUX2	AUX2	
14	AUX1	AUX1	AUX1	AUX1	AUX1	AUX1	AUX1	AUX1	AUX1	AUX1	AUX1	AUX1	
15	AUX1	AUX1	AUX1	AUX1	Butterfly	Butterfly	AUX1	Butterfly	Butterfly	AUX1	Butterfly	Butterfly	
16	AUX1	AUX1	AUX1	Camber	Camber	Camber	Camber	Camber	Camber	Camber	Camber	Camber	
DG1	SW	SW	SW	SW	SW	SW	SW	SW	SW	SW	SW	SW	
DG2	SW	SW	SW	SW	SW	SW	SW	SW	SW	SW	SW	SW	

RX CH	2AIL+4FLAP			4AIL+2FLAP			4AIL+4FLAP			The output CH of each system FASTest 18CH FASTest 12CH 5-FHSS FASTest 7CH FAST MULT
	Airplane	Glider		Airplane	Glider		Airplane	Glider		
		EP			EP			EP		
1	Aileron	Aileron	Aileron	Aileron	Aileron	Aileron	Aileron	Aileron	Aileron	
2	Elevator	Elevator	Elevator	Elevator	Elevator	Elevator	Elevator	Elevator	Elevator	
3	Throttle	Motor	AUX7	Throttle	Motor	AUX7	Throttle	Motor	AUX7	
4	Rudder	Rudder	Rudder	Rudder	Rudder	Rudder	Rudder	Rudder	Rudder	
5	Elevator2	Elevator2	Elevator2	Elevator2	Elevator2	Elevator2	Elevator2	Elevator2	Elevator2	
6	Aileron2	Aileron2	Aileron2	Aileron2	Aileron2	Aileron2	Aileron2	Aileron2	Aileron2	
7	Flap	Flap	Flap	Aileron3	Aileron3	Aileron3	Aileron3	Aileron3	Aileron3	
8	Flap2	Flap2	Flap2	Aileron4	Aileron4	Aileron4	Aileron4	Aileron4	Aileron4	
9	Flap3	Flap3	Flap3	Flap	Flap	Flap	Flap	Flap	Flap	
10	Flap4	Flap4	Flap4	Flap2	Flap2	Flap2	Flap2	Flap2	Flap2	
11	Gear	AUX6	AUX6	Gear	AUX6	AUX6	Flap3	Flap3	Flap3	
12	AUX5	AUX5	AUX5	AUX5	AUX5	AUX5	Flap4	Flap4	Flap4	
13	AUX4	AUX4	AUX4	AUX4	AUX4	AUX4	Gear	AUX6	AUX6	
14	AUX3	AUX3	AUX3	AUX3	AUX3	AUX3	AUX5	AUX5	AUX5	
15	AUX2	Butterfly	Butterfly	AUX2	Butterfly	Butterfly	AUX4	Butterfly	Butterfly	
16	Camber	Camber	Camber	Camber	Camber	Camber	Camber	Camber	Camber	
DG1	SW	SW	SW	SW	SW	SW	SW	SW	SW	
DG2	SW	SW	SW	SW	SW	SW	SW	SW	SW	

•Tailless wing

RX CH	2AIL			2AIL+1FLAP			2AIL+2FLAP		
	Airplane	Glider		Airplane	Glider		Airplane	Glider	
		EP			EP			EP	
1	Aileron	Aileron	Aileron	Aileron	Aileron	Aileron	Aileron	Aileron	Aileron
2	AUX4	AUX4	AUX4	AUX4	AUX4	AUX4	AUX4	AUX4	AUX4
3	Throttle	Motor	AUX7	Throttle	Motor	AUX7	Throttle	Motor	AUX7
4	Rudder	Rudder	Rudder	Rudder	Rudder	Rudder	Rudder	Rudder	Rudder
5	Gear	AUX6	AUX6	Gear	AUX6	AUX6	Aileron2	Aileron2	Aileron2
6	Aileron2	Aileron2	Aileron2	Aileron2	Aileron2	Aileron2	Flap	Flap	Flap
7	AUX5	AUX5	AUX5	Flap	Flap	Flap	Flap2	Flap2	Flap2
8	AUX3	AUX3	AUX3	AUX5	AUX5	AUX5	Gear	AUX6	AUX6
9	AUX2	AUX2	AUX2	AUX3	AUX3	AUX3	AUX5	AUX5	AUX5
10	AUX1	AUX1	AUX1	AUX2	AUX2	AUX2	AUX3	AUX3	AUX3
11	AUX1	AUX1	AUX1	AUX1	AUX1	AUX1	AUX2	AUX2	AUX2
12	AUX1	AUX1	AUX1	AUX1	AUX1	AUX1	AUX1	AUX1	AUX1
13	AUX1	AUX1	AUX1	AUX1	AUX1	AUX1	AUX1	AUX1	AUX1
14	AUX1	AUX1	AUX1	AUX1	Butterfly	Butterfly	AUX1	Butterfly	Butterfly
15	Camber	Camber	Camber	Camber	Camber	Camber	Camber	Camber	Camber
16	Elevator	Elevator	Elevator	Elevator	Elevator	Elevator	Elevator	Elevator	Elevator
DG1	SW	SW	SW	SW	SW	SW	SW	SW	SW
DG2	SW	SW	SW	SW	SW	SW	SW	SW	SW

The output CH of each system
 FASTest 18CH
 FASTest 12CH
 S-FHSS
 FAST ZCH
 FAST MULT

RX CH	2AIL+4FLAP			4AIL+2FLAP			4AIL+4FLAP		
	Airplane	Glider		Airplane	Glider		Airplane	Glider	
		EP			EP			EP	
1	Aileron	Aileron	Aileron	Aileron	Aileron	Aileron	Aileron	Aileron	Aileron
2	Aileron2	Aileron2	Aileron2	Aileron2	Aileron2	Aileron2	Aileron2	Aileron2	Aileron2
3	Throttle	Motor	AUX7	Throttle	Motor	AUX7	Throttle	Motor	AUX7
4	Rudder	Rudder	Rudder	Rudder	Rudder	Rudder	Rudder	Rudder	Rudder
5	Flap	Flap	Flap	Aileron3	Aileron3	Aileron3	Aileron3	Aileron3	Aileron3
6	Flap2	Flap2	Flap2	Aileron4	Aileron4	Aileron4	Aileron4	Aileron4	Aileron4
7	Flap3	Flap3	Flap3	Flap	Flap	Flap	Flap	Flap	Flap
8	Flap4	Flap4	Flap4	Flap2	Flap2	Flap2	Flap2	Flap2	Flap2
9	AUX4	AUX4	AUX4	AUX4	AUX4	AUX4	Flap3	Flap3	Flap3
10	Gear	AUX6	AUX6	Gear	AUX6	AUX6	Flap4	Flap4	Flap4
11	AUX5	AUX5	AUX5	AUX5	AUX5	AUX5	AUX4	AUX4	AUX4
12	AUX3	AUX3	AUX3	AUX3	AUX3	AUX3	Gear	AUX6	AUX6
13	AUX2	AUX2	AUX2	AUX2	AUX2	AUX2	AUX5	AUX5	AUX5
14	AUX1	Butterfly	Butterfly	AUX1	Butterfly	Butterfly	AUX3	Butterfly	Butterfly
15	Camber	Camber	Camber	Camber	Camber	Camber	Camber	Camber	Camber
16	Elevator	Elevator	Elevator	Elevator	Elevator	Elevator	Elevator	Elevator	Elevator
DG1	SW	SW	SW	SW	SW	SW	SW	SW	SW
DG2	SW	SW	SW	SW	SW	SW	SW	SW	SW

The output CH of each system
 FASTest 18CH
 FASTest 12CH
 S-FHSS
 FAST ZCH
 FAST MULT

•Tailless wing Winglet 2Rudder

RX CH	2AIL			2AIL+1FLAP			2AIL+2FLAP			The output CH of each system
	Airplane	Glider		Airplane	Glider		Airplane	Glider		
		EP			EP			EP		
1	Aileron	Aileron	Aileron	Aileron	Aileron	Aileron	Aileron	Aileron	Aileron	FASTest 18CH FASTest 12CH S.FHSS FAST7CH
2	RUD2	RUD2	RUD2	RUD2	RUD2	RUD2	RUD2	RUD2	RUD2	
3	Throttle	Motor	AUX7	Throttle	Motor	AUX7	Throttle	Motor	AUX7	
4	Rudder	Rudder	Rudder	Rudder	Rudder	Rudder	Rudder	Rudder	Rudder	
5	Gear	AUX6	AUX6	Gear	AUX6	AUX6	Aileron2	Aileron2	Aileron2	
6	Aileron2	Aileron2	Aileron2	Aileron2	Aileron2	Aileron2	Flap	Flap	Flap	
7	AUX5	AUX5	AUX5	Flap	Flap	Flap	Flap2	Flap2	Flap2	
8	AUX3	AUX3	AUX3	AUX5	AUX5	AUX5	Gear	AUX6	AUX6	
9	AUX2	AUX2	AUX2	AUX3	AUX3	AUX3	AUX5	AUX5	AUX5	
10	AUX1	AUX1	AUX1	AUX2	AUX2	AUX2	AUX3	AUX3	AUX3	
11	AUX1	AUX1	AUX1	AUX1	AUX1	AUX1	AUX2	AUX2	AUX2	
12	AUX1	AUX1	AUX1	AUX1	AUX1	AUX1	AUX1	AUX1	AUX1	
13	AUX1	AUX1	AUX1	AUX1	AUX1	AUX1	AUX1	AUX1	AUX1	
14	AUX1	AUX1	AUX1	AUX1	Butterfly	Butterfly	AUX1	Butterfly	Butterfly	
15	Camber	Camber	Camber	Camber	Camber	Camber	Camber	Camber	Camber	
16	Elevator	Elevator	Elevator	Elevator	Elevator	Elevator	Elevator	Elevator	Elevator	
DG1	SW	SW	SW	SW	SW	SW	SW	SW	SW	
DG2	SW	SW	SW	SW	SW	SW	SW	SW	SW	

RX CH	2AIL+4FLAP			4AIL+2FLAP			4AIL+4FLAP			The output CH of each system
	Airplane	Glider		Airplane	Glider		Airplane	Glider		
		EP			EP			EP		
1	Aileron	Aileron	Aileron	Aileron	Aileron	Aileron	Aileron	Aileron	Aileron	FASTest 18CH FASTest 12CH S.FHSS FAST7CH
2	Aileron2	Aileron2	Aileron2	Aileron2	Aileron2	Aileron2	Aileron2	Aileron2	Aileron2	
3	Throttle	Motor	AUX7	Throttle	Motor	AUX7	Throttle	Motor	AUX7	
4	Rudder	Rudder	Rudder	Rudder	Rudder	Rudder	Rudder	Rudder	Rudder	
5	Flap	Flap	Flap	Aileron3	Aileron3	Aileron3	Aileron3	Aileron3	Aileron3	
6	Flap2	Flap2	Flap2	Aileron4	Aileron4	Aileron4	Aileron4	Aileron4	Aileron4	
7	Flap3	Flap3	Flap3	Flap	Flap	Flap	Flap	Flap	Flap	
8	Flap4	Flap4	Flap4	Flap2	Flap2	Flap2	Flap2	Flap2	Flap2	
9	RUD2	RUD2	RUD2	RUD2	RUD2	RUD2	Flap3	Flap3	Flap3	
10	Gear	AUX6	AUX6	Gear	AUX6	AUX6	Flap4	Flap4	Flap4	
11	AUX5	AUX5	AUX5	AUX5	AUX5	AUX5	RUD2	RUD2	RUD2	
12	AUX3	AUX3	AUX3	AUX3	AUX3	AUX3	Gear	AUX6	AUX6	
13	AUX2	AUX2	AUX2	AUX2	AUX2	AUX2	AUX5	AUX5	AUX5	
14	AUX1	Butterfly	Butterfly	AUX1	Butterfly	Butterfly	AUX3	Butterfly	Butterfly	
15	Camber	Camber	Camber	Camber	Camber	Camber	Camber	Camber	Camber	
16	Elevator	Elevator	Elevator	Elevator	Elevator	Elevator	Elevator	Elevator	Elevator	
DG1	SW	SW	SW	SW	SW	SW	SW	SW	SW	
DG2	SW	SW	SW	SW	SW	SW	SW	SW	SW	

* Output channels differ by each system of a table. When using a system with few channels, there is a wing type which cannot be used. It cannot be used when there is a function required out of the range of the arrow of a figure.

Helicopter

● FASSTest 18CH / FASST MULTI / FASST 7CH / S-FHSS

CH	H-4/H-4X Swash	All Other
1	Aileron	Aileron
2	Elevator	Elevator
3	Throttle	Throttle
4	Rudder	Rudder
5	Gyro	Gyro
6	Pitch	Pitch
7	Governor	Governor
8	Elevator2	Governor2
9	GYRO2	GYRO2
10	GYRO3	GYRO3
11	Governor2	Needle
12	Needle	AUX5
13	AUX4	
14	AUX3	
15	AUX2	
16	AUX1	
DG1	SW	
DG2		

The output CH of each system
 FASSTest 18CH
 S-FHSS
 FASST 7CH
 FASST MULTI

● FASSTest 12CH

CH	H-4/H-4X Swash	All Other
1	Aileron	Aileron
2	Elevator	Elevator
3	Throttle	Throttle
4	Elevator2	Rudder
5	Pitch	Pitch
6	Gyro	Gyro
7	Governor	Governor
8	Rudder	Governor2
9	GYRO2	GYRO2
10	GYRO3	GYRO3
DG1	SW	
DG2		

The output CH of each system
 FASSTest 12CH

FUNCTIONS OF LINKAGE MENU

The Linkage Menu is made up of functions which perform model addition, model type selection, frequency setting, end point setting, and other model basic settings.

The functions which can be selected depend on the model type. A typical menu screen is shown below.

- Select [LINKAGE] at the home screen and call the linkage menu shown below by touching the RTN button.
- Use the touch sensor to select the function you want to set and call the setup screen by touching the RTN button.

- Select the function name and return to the Linkage menu by touching the RTN button or pushing the Home/Exit button.

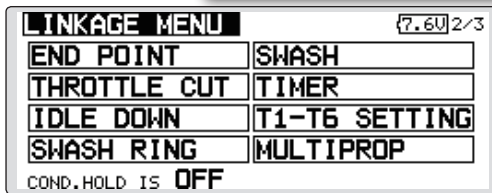
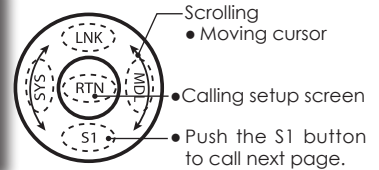
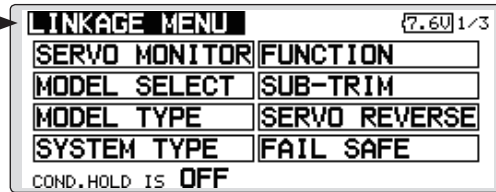

*The display screen is an example. The screen depends on the model type.

To activate/deactivate Condition Hold:
 (Helicopter type only)
 1. Move the cursor to [COND. HOLD].
 2. Set the throttle stick lower than the 1/3 point and touch the RTN button to activate/deactivate the condition hold function.
 *Refer to condition hold function details.

*Condition hold operation is displayed.

Linkage Menu functions table

- [SERVO MONITOR]: Displays the servo test and operation position
- [MODEL SELECT]: Model addition, call, deletion, copy, model name setting
- [MODEL TYPE]: Model type, wing type, swash type, etc. selection
- [SYSTEM TYPE]: System mode selection, link of a transmitter and receiver, area mode selection
- [FUNCTION]: Channel assignment of each function can be changed
- [SUB-TRIM]: Adjusts the neutral position of each servo
- [SERVO-REVERSE]: Servo direction reversal
- [FAIL SAFE]: Fail safe function and battery fail safe function setting
- [END POINT]: Servo basic rudder adjustment and limit setting
- [THROTTLE CUT]: Stops the engine safely and easily (airplane and helicopter only)
- [IDLE DOWN]: Lowers the idle speed of the engine (airplane and helicopter only)
- [SWASH RING]: Limits the swash plate travel to within a fixed range. (helicopter only)
- [SWASH]: Swash AFR and linkage correction function (helicopter only)
- [TIMER]: Timer setting
- [T1-T6 SETTING]: Control step amount and mode selection of the digital trim
- [MULTIPROP]: CH is extended by MPDX-1 of an option
- [FUNCTION NAME]: Function name can be changed
- [TELEMETRY]: Displays various data sent from the receiver
- [SENSOR]: Various telemetry sensors setting
- [TELE.SETTING]: Various telemetry sensors setting
- [WARNING]: Mixing warning normal reset
- [TRAINER]: Starts and sets the trainer system.
- [DATA RESET]: Model memory set data reset (by item)
- [COND. HOLD]: Condition hold function (helicopter only)

SERVO MONITOR

Servo Test & Graph Display / Displays servo positions.

This is used for testing servo movement. “Moving Test” (repetition mode) and “Neutral Test” (fixed position mode) are available.

The “Neutral Test” is good for finding the neutral position of a servo horn.

In order to prevent any potential difficulties, the servo test function will be inoperable, or inaccessible, under certain conditions. Specifically, the Servo Test function is not operational if the Throttle Cut is ON in either airplane or helicopter modes; or if the Throttle Hold is ON in Helicopter mode.

- Select [SERVO MONITOR] at the linkage menu and call the setup screen shown below by touching the RTN button.

- Select the function name and return to the Linkage menu by touching the RTN button or pushing the Home/Exit button.

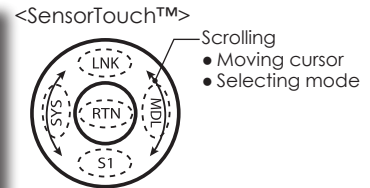
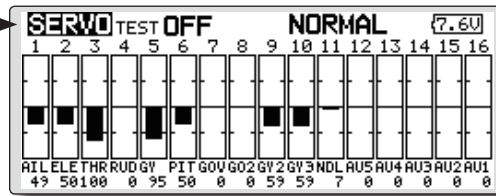

*The display screen is an example. The screen depends on the model type.

Servo test operation

1. Use the touch sensor to move the cursor to the [TEST] item and touch the RTN button to switch to the data input mode.

Select the test mode by turning the touch sensor to the left or right and touch the RTN button.

[MOVING]: Mode which repeats operation of each servo

[NEUTRAL]: Mode which locks each servo in the neutral position

2. Use the touch sensor to move the cursor to the [TEST] item and touch the RTN button to switch to the data input mode.

Select the [OFF] by turning the touch sensor and touch the RTN button. Testing is stopped.

⚠ WARNING

- ❗ Don't set a servo test mode when the drive motor is connected and the engine was started.
- Inadvertent rotation of the motor or acceleration of the engine is extremely dangerous.

MODEL SELECT

The Model Selection function performs model addition, call, deletion, copy, and model name setting.

This function is used to load the settings of the desired model into the T18SZ's memory.

The settings may be selected from either the transmitter's built-in memory or a SD card (32MB-2GB). Remember that up to 30 model memories are available in the transmitter.

The name of the model stored in the transmitter and the SD card may be changed. This can be very useful to tell different models settings apart. Each

model name can be as long as 15 characters, and the model name always appears in the display screen.

The Copy function is used to copy one set of model data into a second memory within the transmitter and the SD card. It may be used for getting a head-start on setting up models with almost the same settings (only differences need to be modified, instead of entering the complete model from scratch). Also, this function may be used to make a backup copy of a model setup before any changes are made.

- Select [MODEL SELECT] at the linkage menu and call the setup screen shown below by touching the RTN button.

- Select the function name and return to the Linkage menu by touching the RTN button or pushing the Home/Exit button.

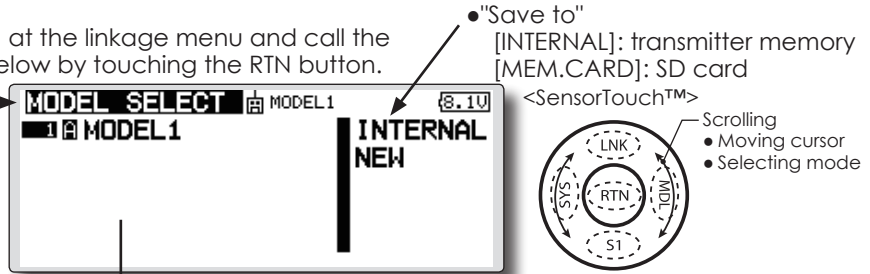

(Model list)

*The display screen is an example. The screen depends on the model type.

Model call

*Model data saved at models other than the model currently used or saved on a SD card can be called.

1. Use the touch sensor to move to the save destination ("INTERNAL" or "MEM.CARD") and touch the RTN button to switch to the data input mode.

Select the location which is to save the desired model by turning the touch sensor to the left or right. Touch the RTN button.

[INTERNAL]: Transmitter memory
[MEM. CARD]: SD card

2. After using the touch sensor to move the cursor to the desired model in the model list, touch the RTN button.
3. Use the touch sensor to move to [SELECT].
4. Touch the RTN button. When a confirmation message is displayed and the RTN button is touched again, calling is complete.

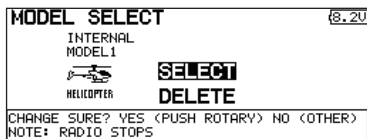

*Transmission stops and a send with new model confirmation message ("TRANSMIT?") appears.

5. To start transmission, use the touch sensor to select [YES] and then touch the RTN button. To not transmit, select [NO] and touch the RTN button.

Model addition

*A new model can be added to the transmitter memory or SD card.

1. Use the touch sensor to move the cursor to the save destination ("INTERNAL" or "MEM.CARD") and touch the RTN button to switch to the data input mode.

Select the save destination by turning the touch sensor to the left or right. Touch the RTN button.

[INTERNAL]: Transmitter memory
[MEM. CARD]: SD card

2. Use the touch sensor to move to [NEW].
3. Press the RTN button. A confirmation message appears. Press the RTN button again.

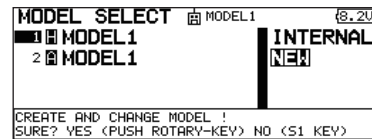

*The model type setup screen and frequency setup screen are automatically displayed. Confirm or change the model type and frequency.

*A starting transmission with new model confirmation message ("TRANSMIT") appears.

4. To start transmission, use the touch sensor to select [YES] and then touch the RTN button. To not transmit, select [NO] and touch the RTN button.

*The added model appears in the model list.

Model deletion

*The model stored in the transmitter memory or a SD card can be deleted.

*The current model can not be deleted.

1. Use the touch sensor to move the cursor to the save destination display ("INTERNAL" or "MEM. CARD") and touch the RTN button to switch to the data input mode.

Select the save destination by turning the touch sensor to the left or right and touch the RTN button.

[INTERNAL]: Transmitter memory

[MEM. CARD]: SD card

2. Use the touch sensor to move the cursor to the model you want to delete in the model list and then touch the RTN button.
3. Move the cursor to [DELETE].
4. Touch the RTN button. When a confirmation message is displayed and the RTN button is touched again, the model is deleted.

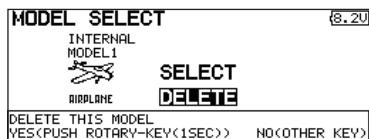

Model name change

*The current model's name can be changed.

1. Use the touch sensor to select the current model in the model list and then touch the RTN button.
2. Use the touch sensor to move to [RENAME].
3. Touch the RTN button.

*The model name setup screen is displayed.

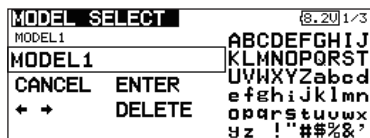

4. Change the model name as described below:

[Moving cursor in input box]

Select [←] or [→], and touch the RTN button.

[Deleting a character]

When [DELETE] is selected and the RTN button is touched, the character immediately after the cursor is deleted.

[Adding a character]

When a candidate character is selected from the character list and the RTN button

is touched, that character is added at the position immediately after the cursor.

*A name of up to 8 characters long can be entered as the model name. (A space is also counted as 1 character.)

5. At the end of input, select [ENTER] and touch the RTN button. (To terminate input and return to the original state, select [CANCEL] and touch the RTN button.)

Model copy

*A copy can be made of the current model.

1. Use the touch sensor to select the current model in the model list and then touch the RTN button.
2. Move to [COPY] with the touch sensor.
3. Touch the RTN button.

*The copy screen appears.

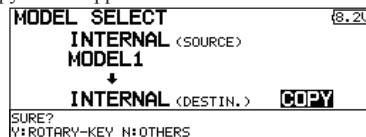

4. Use the touch sensor to move to the copy destination position at the bottom of the screen and touch the RTN button to switch to the data input mode.

Select the save destination by turning the touch sensor and touch the RTN button.

5. Use the touch sensor to move to [COPY].
6. Touch the RTN button. When a confirmation message is displayed and the RTN button is touched again, the model data is copied.

*T18SZ accepts a SD card formatted FAT file system, but it does not supports the long file name feature used in Windows or other modern operating systems. Thus T18SZ can accept files whose name consists of only 8 characters or less. Furthermore, it supports only basic alphanumeric characters such as 'A' to 'Z', '0' to '9' and '_'.

MODEL TYPE

This function selects the model type from among airplane, helicopter, and glider.

Seven types of main wings and three types of tail wings are available for airplanes. Eight swash types are available for helicopters. Seven types of main wings and three types of tail wings are available for gliders. Functions and mixing functions necessary for each model type are set in advance at the factory.

Note: The Model Type function automatically selects the appropriate output channels, control functions, and mixing functions for the chosen model type.

When the Model Type Selection command is accessed, all of the data in the active memory is cleared (except the following swash type.) Be sure that you don't mind losing this data, or back it up to another memory using the copying functions.

When you change the helicopter swash type within the following each group, you can leave the setting data other than the SWASH function. In this case, confirmation screen appears. However, it is initialized when you change the swash type exceeding the group.

- Select [MODEL TYPE] at the linkage menu and call the setup screen shown below by touching the RTN button.

Swash type group A:
H-1, H-2, H-3, HR3, HN3, and HE3
Swash type group B:
H-4, H-4X

- Select the function name and return to the Linkage menu by touching the RTN button or pushing the Home/Exit button.

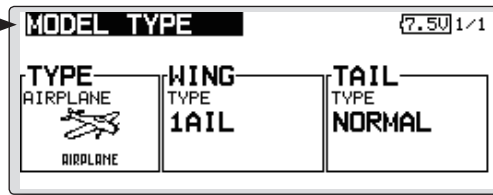

<SensorTouch™>

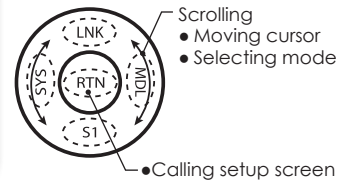

(The display screen is an example. The screen depends on the model type.)

Model type selection

1. Use the touch sensor to move the cursor to the item you want to change and then call the selection screen by touching the RTN button.

"TYPE": Model type

"WING " (airplane/glider): Wing type

"TAIL" (airplane/glider): Tail type

"SWASH" (helicopter): Swash type

2. Use the touch sensor to move the cursor to the type you want to change and select the type by touching the RTN button.

*When the model type was changed, the wing type, tail type, or swash type selection screens sequentially appear according to the model. Finally, the blinking confirmation message "MODEL TYPE CONFIRMATION" appears.



3. Touch the RTN button to execute the change. (Operate the touch sensor or S1 button to stop the change.)

*The model types which are displayed (which can be selected) depend on the type of receiver used. See Servo Connection by Model Type.

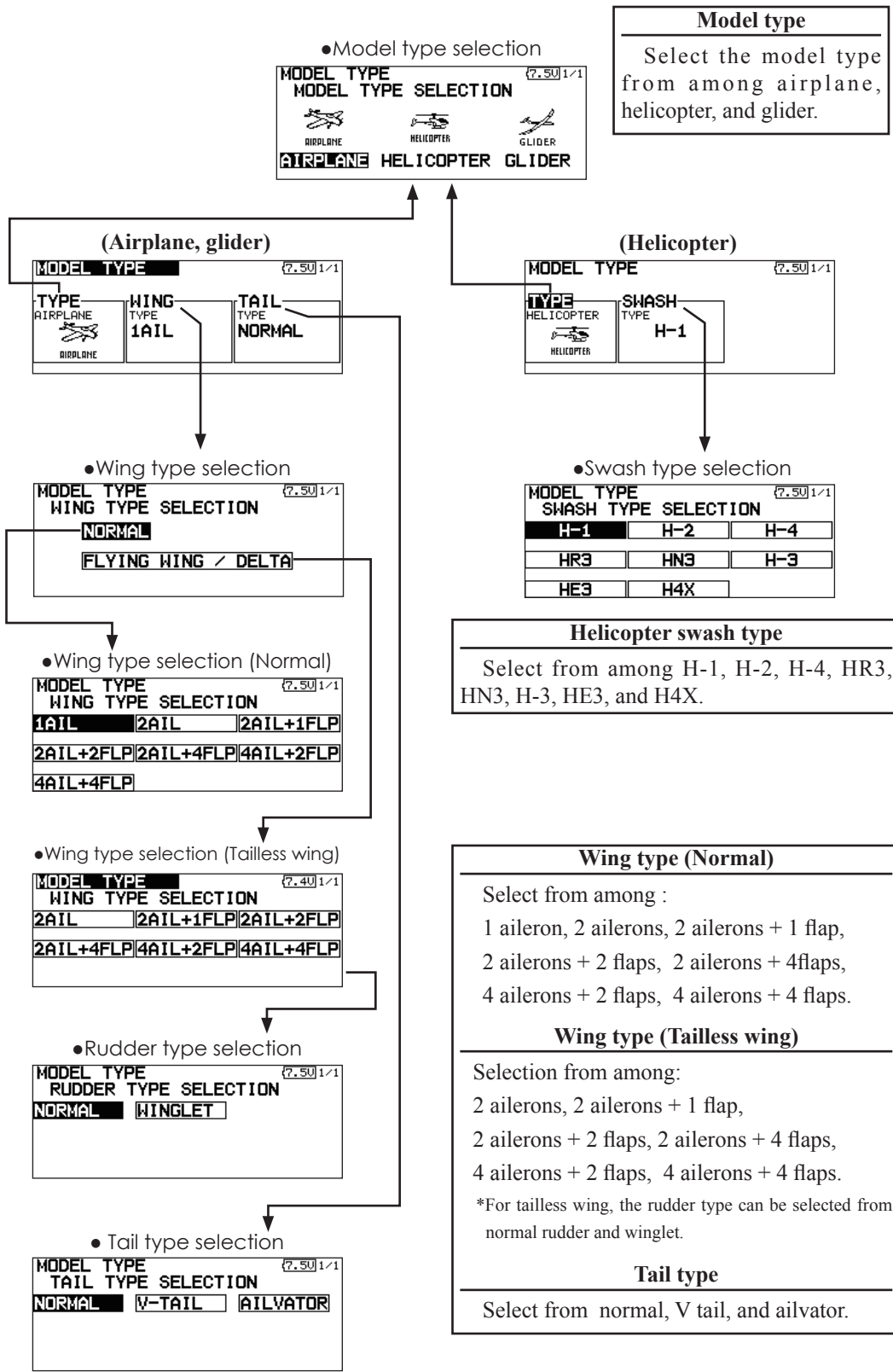

Model type

Select the model type from among airplane, helicopter, and glider.

Helicopter swash type

Select from among H-1, H-2, H-4, HR3, HN3, H-3, HE3, and H4X.

Wing type (Normal)

Select from among :

- 1 aileron, 2 ailerons, 2 ailerons + 1 flap,
- 2 ailerons + 2 flaps, 2 ailerons + 4 flaps,
- 4 ailerons + 2 flaps, 4 ailerons + 4 flaps.

Wing type (Tailless wing)

Selection from among:

- 2 ailerons, 2 ailerons + 1 flap,
- 2 ailerons + 2 flaps, 2 ailerons + 4 flaps,
- 4 ailerons + 2 flaps, 4 ailerons + 4 flaps.

*For tailless wing, the rudder type can be selected from normal rudder and winglet.

Tail type

Select from normal, V tail, and ailvator.

Model type selection (Airplane, Glider)

•Wing type (Normal)

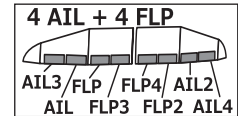
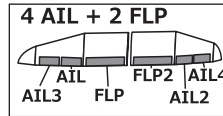
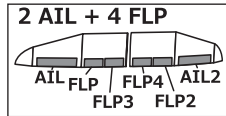
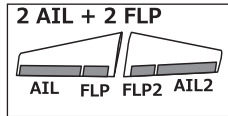
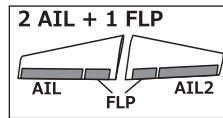
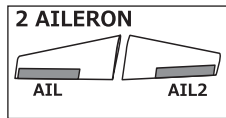
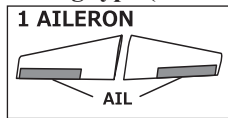

•Wing type (Tailless wing)

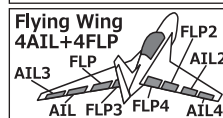
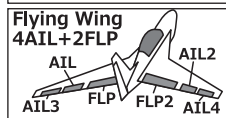
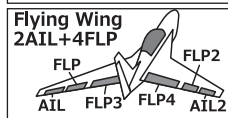
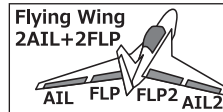
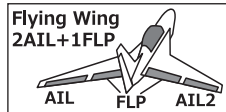
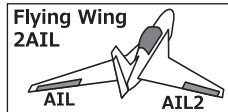

•Rudder type

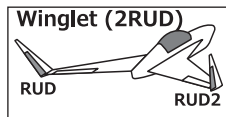
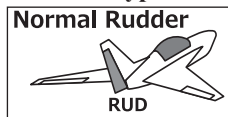

•Tail type

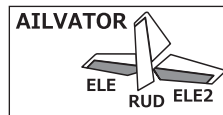
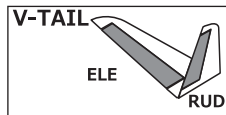
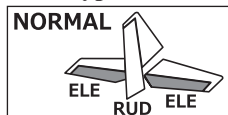

Model type selection (Helicopter)

•Swash type

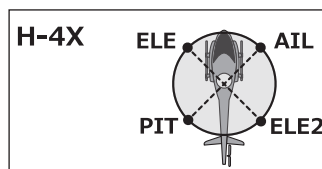
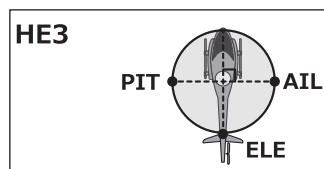
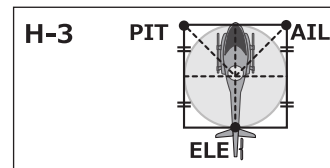
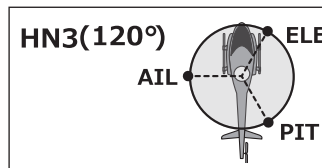
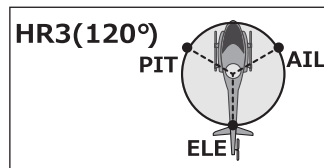
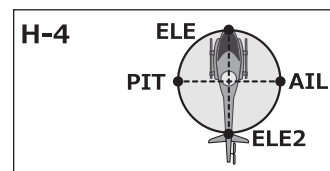
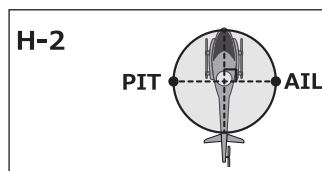
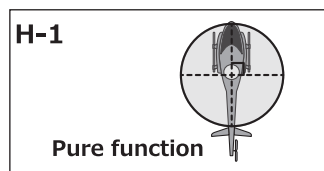

System Type selection

The T18SZ is for 2.4GHz only. The system can be changed from among 5 choices: FASSTest 18CH, FASSTest 12CH, FASST MULTI, FASST 7CH, T-FHSS, S-FHSS. It is FASSTest18CH and FASSTest12CH which can be chosen by R7008SB set. The method of selection is to the next page.

*If you change the System Type, other model data is not reset.

*If a system type is changed in Helicopter mode, the transmitter will offer two selections:

[Yes] : Selection sets the channel order suitable for System Type. (We recommend here.)

[No] : The present channel order is maintained.

*After any change, remember to test the model and should fully check servo direction and a motion.

*Analog servos cannot be used with the R7008SB in the FASSTest 12CH mode.

- Select [SYSTEM] in the Linkage menu and access the setup screen shown below by touching the RTN button.

- Select the function name and return to the Linkage menu by touching the RTN button or pushing the Home/Exit button.

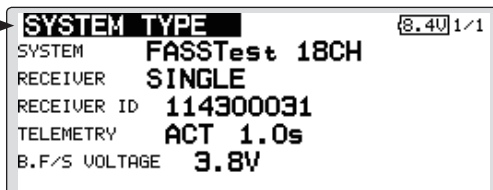

<SensorTouch™>

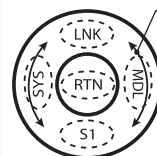

Scrolling

- Moving cursor
- Selecting mode
- Adjusting value

Receiver linking

The receiver will only be controlled (without being affected by other transmitters) by the transmitter it is linked to. When using a receiver other than one purchased as a set, linking is necessary.

Moreover, a re-link is required when a new model is added by model selection, and the time of system type change.

Cases when linking is necessary:

- When using a receiver other than the initial setting.
- When the communication system was changed. (FASSTest18CH ↔ FASSTest12CH etc.)
- When a new model was created by model selection.

Battery fail-safe voltage setup (only FASSTest / T-FHSS mode)

The voltage which battery fail-safe activates, can be set when you link. (3.5-8.4V) The receiver memorizes the setting as it was at link.

Suggested setting voltages are as follows.

- 4 cells NiCd or NiMH (Normal: 4.8v) = 3.8 v
- 2 cells LiFe (Normal: 6.6 v) = 6.0 ~ 6.2 v
- 2 cells LiPo (Normal: 7.4 v) = 6.6 ~ 7.4 v

It is a rough reference value.

Since it changes with servos carried in the condition and the model of a battery, please set to your own model in a battery consumption current.

Linking method

P.36

Telemetry function (FASSTest /T-FHSS mode only)

To use the telemetry function, set “Telemetry” to “ACT”.

DL Interval (FASSTest/T-FHSS mode only)

When a telemetry function is enabled, the receiving interval (down-link interval) of sensor data can be changed.

If a DL interval is increased, the response of the sensor data display becomes slower, but stick response will improve.

System Type selection procedure

1. Move the cursor to the [FASSTest-18CH] item and touch the RTN button to switch to the data



2. Select the system type by scrolling the touch sensor.

[FASSTest-18CH][FASSTest-12CH][FASST-MULT]
 [FASST-7CH][S-FHSS]

*An example of selections for each system is on the following page.

3. Touch the RTN button to end adjustment and return to the cursor mode.

Dual receiver function (only FASSTest 18CH / T-FHSS mode) procedure

1. Move the cursor to the [SINGLE] item and touch the RTN button to switch to the data input mode.

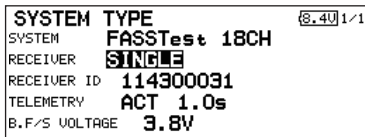

2. Select the [SINGLE] or [DUAL] by scrolling the touch sensor.
 ID of a Primary receiver displays. ID of a Secondary receiver displays.

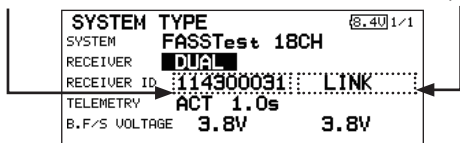

In DUAL, a primary receiver is link previously. Next, a secondary receiver is link.

3. Touch the RTN button to end adjustment and return to the cursor mode.

Telemetry ACT/INH procedure

1. Move the cursor to the TELEMETRY [ACT] item and touch the RTN button to switch to the data

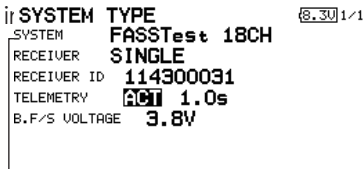

2. Select the [ACT]or[INH] by scrolling the touch sensor.
3. Touch the RTN button to end adjustment and return to the cursor mode.

DL Interval set procedure

1. Move the cursor to the TELEMETRY DL[1.0s] item and touch the RTN button to switch to the dc

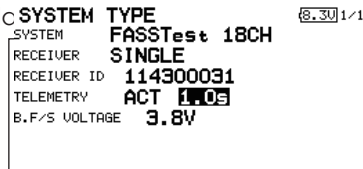

2. Select the DL time by scrolling the touch sensor. If a DL interval is increased, the response of the sensor data display becomes slower, but stick response will improve.

Initial value: 1.0s

Adjustment range : 0.1s~2.0s

3. Touch the RTN button to end adjustment and

The example for choosing System Type

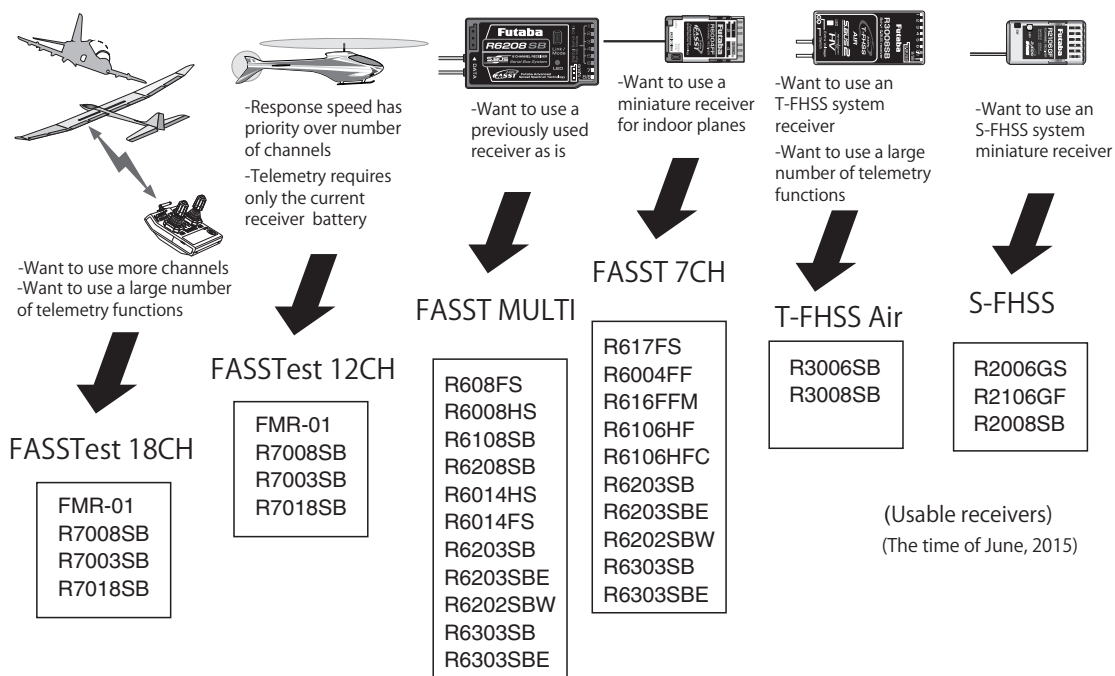

System Type

- **FASSTest 18CH** --- FASSTest system receiver mode. Applicable with the telemetry sensor unit. Up to 18 channels (linear 16+ON/OFF2) can be used.
- **FASSTest 12CH** --- FASSTest system receiver mode. Applicable with receiver voltage display. Up to 12 channels (linear 10+ON/OFF2) can be used. Telemetry Sensor cannot be used, but the response speed is a faster than that of the 18CH mode.
 - **Analog servos cannot be used with the R7008SB in the FASSTest 12CH mode.**
- **FASST MULTI** --- FASST-MULTI system receiver mode. Up to 18 channels (linear 16+ON/OFF2) can be used.
- **FASST 7CH** --- FASST-7CH system receiver mode. Up to 7 channels can be used.
- **T-FHSS Air** --- T-FHSS system receiver mode. Applicable with the telemetry sensor unit. Up to 18 channels (linear 16+ON/OFF2) can be used.
- **S-FHSS** --- S-FHSS system receiver mode. Up to 8 channels can be used.

FUNCTION

Channel assignment of each function can be changed.

When you select model and wing (swash) types, you will find that the optimized combinations of servo output channels and functions have been already preset. If you would like, you can freely change combinations of servo output channels, functions (aileron, elevator, etc), and control (sticks, switches, and trim levers).

*You can also assign the same function to multiple servo output channels such as assigning elevator function to CH2 and CH3.

Channel Replacement

When the channel is replaced in the function menu, replaced channel uses the setting data (ATV, SUB-TRIM, REVERSE, F/S, and B-F/S, etc.).

Servo Output Channels

For FASSTest 14CH mode, you can set 12 linear

channels and two digital channels. For FASSTest 18CH mode, you can set 10 linear channels and two digital channels. For FASST MULT mode, you can set 12 linear channels and two digital channels. For FASST 7CH mode, you can set only 7 linear channels. For S-FHSS mode, you can set only 8 linear channels.

*DG1/2 (digital channels)

These channels can function as switched channels. You can freely change combinations between servo output channels and input controls (sticks, switches, and trim levers).

Motor Function

If you have either a glider or airplane model type selected, and choose to activate the motor function, a reverse setting screen is displayed.

*If "YES" is selected, the output is reversed. If "NO" is selected, the output is normal.

- Select [FUNCTION] at the linkage menu and call the setup screen shown below by touching the RTN button.
- Select the function name and return to the Linkage menu by touching the RTN button or pushing the Home/Exit button.
- Trim operation mode
"COMB": Combination mode
"SEPAR": Separate mode

FUNCTION		NORMAL	8.20	1/5
CH	FUNCTION	CONTROL	---	TRIM
1	AILERON	J1	T1	SEPAR
2	ELEVATOR	J3	T3	SEPAR
3	THROTTLE	J2	T2	SEPAR
4	RUDDER	J4	T4	SEPAR

(The display screen is an example. The screen depends on the model type.)

- Scrolling
- Moving cursor
- Selecting mode
- Push the S1 button to call next page.

Function change

1. Use the touch sensor to move the cursor to the "FUNCTION" item of the channel you want to change and touch the RTN button.

*The function selection screen is displayed.

2. Use the touch sensor to move the cursor to the function name you want to set and touch the RTN button.

*The function name blinks.

3. Touch the RTN button to execute the change. (When you want to cancel this operation, operate the touch sensor or S1 button.)

*Multiple channels can be assigned to one function.

Operation control change

1. Use the touch sensor to move the cursor to the "CONTROL" item of the channel you want to change and touch the RTN button.

*The control selection screen is displayed.

HARDWARE SEL.		CONDIT1	7.50	1/1
J1	SA SE LD T1 T5			
J2	SB SF RD T2 T6			
J3	SC SG LS T3 --			
J4	SD SH RS T4			

2. Use the touch sensor to move the cursor to the control you want to change, and touch the RTN button.

*The same control can be assigned to multiple channels.

*The setting can be changed for each condition.

After the set mode is changed from group mode [G] to single mode [S] at the control selection screen, only that condition setting is changed by control change; setting of other conditions remains the same.

Trim setting

Use the touch sensor to move the cursor to the "TRIM" item of the channel you want to change and touch the RTN button.

*The trim setup screen is displayed.

HARDWARE SEL.		CONDIT1		(7.50) 1/1	
HARDWARE LIST					
J1	SA	SE	LD	T5	30%
J2	SB	SF	RD	T6	MODE
J3	SC	SG	LS	T3	NORMAL
J4	SD	SH	RS	T4	

The following items can be set at the trim setup screen:

*The setting can be changed for each condition.

After the set mode is changed from group mode [G] to single mode [S] at the control selection screen, only that condition setting is changed by control change; setting of other conditions remains the same.

Trim selection

Use the touch sensor to move the cursor to the trim, lever, etc. you want to set and touch the RTN button.

*The setting can be changed.

Trim rate setting

Use the touch sensor to move the cursor to the [RATE] item and touch the RTN button to switch to the data input mode.

Set the trim rate by turning the touch sensor.

Initial value: +30%

Adjustment range : 0~150%

(When the RTN button is touched for 1 second, the trim rate is reset to the initial value.)

Touch the RTN button to end adjustment and return to the cursor move mode.

Trim mode selection

Use the touch sensor to move the cursor to the [TRIM MODE] item and select the trim mode by turning the touch sensor.

[NORM]: Normal mode. Normal trim (parallel shift trim) operation.

[ATL]: ATL operation mode. Maximum change near center by operation normally used with throttle trim. Reverse is also possible.

[NORM]/[REV] selection is possible at the "ATL REV" item.

[CENTER]: Maximum change near center by center trim operation.

⚠ WARNING

❗ As a safety precaution to prevent the motor from starting unexpectedly, please switch off the motor accordingly. We also suggest removing the propeller from the motor as an additional precaution.

SUB-TRIM

Setting of neutral position of each servo.

The Sub-Trim function is used to set the servo neutral position, and may be used to make fine adjustments to the control surface after linkages and touchrods are hooked up. When you begin to set up a model, be sure that the digital trims are set to their center position.

- Select [SUB-TRIM] at the linkage menu and call the setup screen shown below by touching the RTN button.

- Select the function name and return to the Linkage menu by touching the RTN button or pushing the Home/Exit button.

SUB-TRIM				[8.20] 1/2	
CH FUNCTION		CH FUNCTION			
1 AILERON	+0	5 GYRO<RUD>	+0		
2 ELEVATOR	+0	6 PITCH	+0		
3 THROTTLE	+0	7 GOVERNOR	+0		
4 RUDDER	+0	8 GOVERNOR2	+0		

(The display screen is an example. The screen depends on the model type.)

<SensorTouch™>

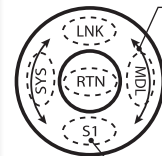

- Scrolling
- Moving cursor
- Adjusting value

- Push the S1 button to call next page.

Sub trim adjustment

1. Use the touch sensor to move the cursor to the channel you want to adjust and touch the RTN button to switch to the data input mode.
2. Adjust by turning the touch sensor.
Initial value: 0
Adjustment range: -240~+240 (steps)
(When the RTN button is touched for 1 second, sub trim is reset to the initial value.)
*Before sub trim adjustment, adjustment of the linkage so that control surfaces need not use sub trim as much as possible is very important.
3. Repeat this procedure for each channel.

SERVO-REVERSE

Use to reverse the throw direction.

Servo Reverse changes the direction of an individual servo's response to a control stick movement.

For CCPM helicopters, be sure to read the section on Swash AFR before reversing any servos. With CCPM helicopters, always complete your servo reversing prior to any other programming. If you use pre-built Airplane/Sailplane functions

that control multiple servos, it may be confusing to tell whether the servo needs to be reversed or a setting in the function needs to be reversed. See the instructions for each specialized function for further details. Always check servo direction prior to every flight as an additional precaution to confirm proper model memory, hook ups, and radio function.

- Select [SERVO REVERSE] at the linkage menu and call the setup screen shown below by touching the RTN button.

- Select the function name and return to the Linkage menu by touching the RTN button or pushing the Home/Exit button.

SERVO REVERSE			[8.20] 1/3		
CH	FUNCTION	MODE	CH	FUNCTION	MODE
1	AILERON	NORM	5	GYRO<RUD>	NORM
2	ELEVATOR	NORM	6	PITCH	NORM
3	THROTTLE	NORM	7	GOVERNOR	NORM
4	RUDDER	NORM	8	GOVERNOR2	NORM

(The display screen is an example. The screen depends on the model type.)

• Push the S1 button to call next page.

Servo reversing procedure

- *After linkage of a new model is complete, check whether or not each servo is connected to the correct channel.
 - *Next, determine whether you need to reverse any channels by moving each stick.
1. Use the touch sensor to move the cursor to the channel you want to reverse and touch the RTN button to switch to the data input mode.
 2. Turn the touch sensor and change the display to [REVERSE] (or [NORMAL]).
 - *The display blinks.
 3. When the RTN button is touched, servo operation is reversed. (Operate touch sensor or S1 button to stop reversal.)
 - *Repeat the operation above for each channel that must be reversed.

FAIL SAFE

Sets the servos operating position when transmitter signals can no longer be received or when the receiver battery voltage drops.

The Failsafe function may be used to set up positions that the servos move to in the case of radio interference.

You may set either of two positions for each channel: Hold, where the servo maintains its last commanded position, or Failsafe, where each servo moves to a predetermined position. You may choose either mode for each channel. (**FASST 7CH mode: CH3 only**)

The T18SZ system also provides you with an advanced battery monitoring function that warns you when the receiver battery has only a little power remaining. In this case, each servo is moved to the defined failsafe position. (**FASST 7CH mode: CH3 only**) The battery failsafe may be released by operating a predefined control on the transmitter, do not continue to fly, land as soon as possible. Remember, if the predefined

control suddenly moves to a position you did not command, land at once and check your receiver battery.

Defines servo position when signals are lost and when receiver battery voltage becomes low.

⚠ WARNING

❗ For safety, always set the fail safe functions.

- Remember to set the throttle channel fail safe function so that the servo moves to the maximum slow side for airplanes and to the slow side from the hovering position for helicopters. Crashing of the model at full high when normal radio waves cannot be received due to interference, etc., is very dangerous.
- If the battery fail safe is reset by the throttle stick, it may be mistaken for an engine malfunction and will be reset at throttle slow and the model will continue to fly. If you have any doubts, immediately land.

- Select [FAIL SAFE] at the linkage menu and call the setup screen shown below by touching the RTN button.

(The display screen is an example. The screen depends on the model type.)

- Select the function name and return to the Linkage menu by touching the RTN button or pushing the Home/Exit button.

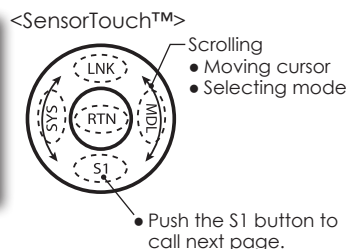
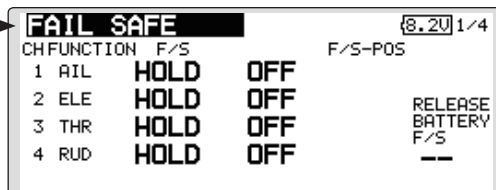

Fail safe setting procedure

1. Move the cursor to the "F/S" item of the channel you want to set and touch the RTN button to switch to the data input mode.
2. Select the F/S mode by scrolling the touch sensor. A confirmation message appears.
 - *The display blinks.
3. Touch the RTN button. (Touch the S1 button to stop setting.)
 - *The channel switches to the F/S mode.
4. Move the cursor to the "POS" item.

Hold the corresponding stick, knob, slider, etc. in the position you want the servo to move to when the fail safe function is activated and touch the RTN button for one second.

*The set position is displayed in percentage.

*If you want to return that channel to the hold mode, move the cursor to the "F/S" item and touch the RTN button to switch to the data input mode. Select the F/S mode by scrolling the touch sensor. A confirmation message appears and then change the mode by touching the RTN button.

Battery fail safe setting procedure

Battery fail safe can be set for each channel by the same method as the fail safe setting procedure. Select and set the "B.F/S" item.

[ON]: Battery fail safe function ON

[OFF]: Battery fail safe function OFF

Battery fail safe release switch setting

This function temporarily releases the battery fail safe function, so the fuselage can recover after the battery fail safe function was activated by a drop in the receiver battery voltage. This setting selects the switch which releases the battery fail safe function.

1. Move the cursor to the [RELEASE B.F/S] item in the setup screen (last page).
2. Touch the RTN button.

*The switch selection screen is called.

*For a detailed description of the switch selection and ON/OFF direction setting method, see [Switch Setting Method] at the back of this manual.

END POINT

Sets the travel, limit point, and speed of each servo.

The End Point function adjusts the left and right servo throws, generates differential throws, and will correct improper linkage settings.

The travel rate can be varied from 30% to 140% in each direction on channels 1 to 12. Also, the limit point where servo throw stops may be varied from 0% to 155%.

- Select [END POINT] at the linkage menu and call the setup screen shown below by touching the RTN button.

- Select the function name and return to the Linkage menu by touching the RTN button or pushing the Home/Exit button.

CH FUNCTION	LIMIT	TRAV.	TRAV.	LIMIT SPEED
1 AILERON	135%	100%	100%	135%
2 ELEVATOR	135%	100%	100%	135%
3 THROTTLE	135%	100%	100%	135%
4 RUDDER	135%	100%	100%	135%

(The display screen is an example. The screen depends on the model type.)

<SensorTouch™>

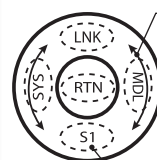

- Scrolling
- Moving cursor
- Adjusting value

- Push the S1 button to call next page.

Servo travel adjustment

1. Use the touch sensor to move the cursor to the "TRAV." item of the channel you want to adjust and touch the RTN button to switch to the data input mode.
2. Turn the touch sensor to adjust the rate.
Initial value: 100%
Adjustment range: 30%~140%
(When the RTN button is touched for 1 second, the rate is reset to the initial value.)
Touch the RTN button to end adjustment and return to the cursor move mode.
3. Repeat this procedure for each rate.

Limit point adjustment

1. Use the touch sensor to move the cursor to the "LIMIT" item of the channel you want to adjust and touch the RTN button to switch to the data input mode.
2. Turn the touch sensor to adjust the limit point.
Initial value: 135%
Adjustment range: 0%~155%
(When the RTN button is touched for 1 second, the limit point is reset to the initial value.)
Touch the RTN button to end adjustment and return to the cursor move mode.
3. Repeat this procedure for each limit point.

NOTE: The servo speed setting is used to set the servo delay for each channel, from channel 1 to channel 12. The system uses the programmed speed (delay) to slow down servo position changes. The servo speed setting can be varied from 0 to 27 in each channel.

Servo speed setting

1. Use the touch sensor to move the cursor to the "SPEED" item of the channel you want to adjust and touch the RTN button to switch to the data input mode.
2. Turn the touch sensor to adjust the servo speed.
Initial value: 0
Adjustment range: 0~27 (steps)
(When the RTN button is touched for 1 second, the servo speed is reset to the initial value.)
Touch the RTN button to end adjustment and return to the cursor move mode.
3. Repeat this procedure for each channel.

THROTTLE CUT

Stops the engine safely and easily.(airplane and helicopter only)

Throttle cut provides an easy way to stop the engine, by flipping a switch with the throttle stick at idle. The action is not functional at high throttle to avoid accidental dead sticks. The switch's location and direction must be chosen, as it defaults to NULL.

- Select [THROTTLE CUT] at the linkage menu and call the setup screen shown below by touching the RTN button.

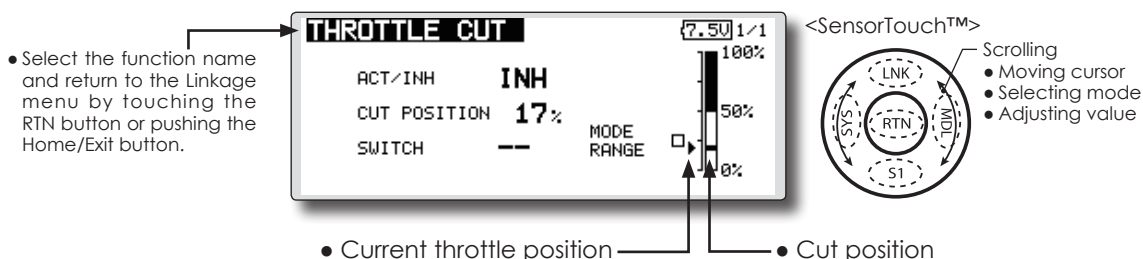

Throttle cut setting procedure

*Perform the following settings before using the touch sensor to move the cursor to the item to be set.

1. Activate the function:

Move the cursor to the [ACT/INH] item and touch the RTN button to switch to the data input mode.

Turn the touch sensor to the left until the blinking changes from "INH" to "ACT" and then touch the RTN button.

2. Switch setting:

Move the cursor to the [SWITCH] item and call the switch setup screen by pressing the RTN button and select the switch and ON direction.

(For a detailed description of the setting method, see [Switch Setting Method] at the back of this manual.)

3. Throttle cut position setting:

Move the cursor to the [CUT POSITION] item and touch the RTN button to switch to the data input mode.

Adjust the servo operation position at throttle cut operation by turning the touch sensor to the left or right.

Initial value: 17%

Adjustment range: 0%~50%

(When the RTN button is pressed for 1 second, the servo operation position is reset to the initial value.)

Touch the RTN button to end adjustment and return to the cursor move mode.

*With the selected cut switch ON and the throttle stick at idle; adjust the rate until the engine consistently cuts off.

However, be sure that the throttle linkage is not pulled too tight and unreasonable force is not applied to the servo.

IDLE DOWN

Lowers the engine idling speed. (airplane and helicopter only)

The Idle Down function lowers the engines idle by flipping a switch with the throttle stick at idle. The action is not functional at high throttle to avoid accidental dead sticks. The switch's location and direction must be chosen, as it defaults to NULL.

- Select [IDLE DOWN] at the linkage menu and call the setup screen shown below by touching the RTN button.

• Select the function name and return to the Linkage menu by touching the RTN button or pushing the Home/Exit button.

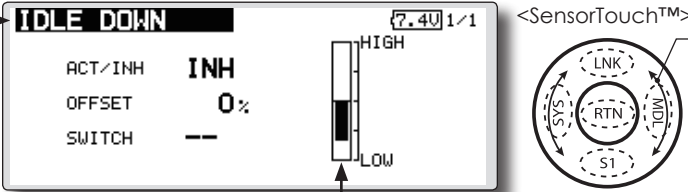

The screenshot shows the 'IDLE DOWN' setup screen with the following fields: 'ACT/INH' set to 'INH', 'OFFSET' set to '0%', and 'SWITCH' set to '--'. A vertical slider is positioned between 'HIGH' and 'LOW', with a black bar indicating the current throttle position. The top right corner of the screen shows '7.40 1/1'. To the right is a circular 'SensorTouch™' control diagram with buttons labeled 'LNK', 'RTN', 'S1', 'S2', 'S3', 'S4', 'S5', 'S6', 'S7', 'S8', 'S9', 'S10', 'S11', 'S12', 'S13', 'S14', 'S15', 'S16', 'S17', 'S18', 'S19', 'S20', 'S21', 'S22', 'S23', 'S24', 'S25', 'S26', 'S27', 'S28', 'S29', 'S30', 'S31', 'S32', 'S33', 'S34', 'S35', 'S36', 'S37', 'S38', 'S39', 'S40', 'S41', 'S42', 'S43', 'S44', 'S45', 'S46', 'S47', 'S48', 'S49', 'S50', 'S51', 'S52', 'S53', 'S54', 'S55', 'S56', 'S57', 'S58', 'S59', 'S60', 'S61', 'S62', 'S63', 'S64', 'S65', 'S66', 'S67', 'S68', 'S69', 'S70', 'S71', 'S72', 'S73', 'S74', 'S75', 'S76', 'S77', 'S78', 'S79', 'S80', 'S81', 'S82', 'S83', 'S84', 'S85', 'S86', 'S87', 'S88', 'S89', 'S90', 'S91', 'S92', 'S93', 'S94', 'S95', 'S96', 'S97', 'S98', 'S99', 'S100'. A legend indicates: Scrolling (moving cursor), Selecting mode (touching RTN), and Adjusting value (turning the sensor).

• Current throttle position

Idle down setting procedure

*Perform the following settings after using the touch sensor to move the cursor to the item you want to set.

1. Activate the function:

Move the cursor to the [ACT/INH] item and touch the RTN button to switch to the data input mode.

Switch the blinking from "INH" to "ACT" by turning the touch sensor to the left and then touch the RTN button.

2. Switch setting:

Move the cursor to the [SWITCH] item, call the switch setup screen by touching the RTN button, and select the switch and ON direction.

(For a detailed description of the setting method, see [Switch Setting Method] at the back of this manual.)

3. Offset rate setting:

Move the cursor to the [OFFSET] item and touch the RTN button to switch to the data input mode.

Adjust the servo offset rate at idle down operation by turning the touch sensor to the left or right.

Initial value: 0%

Adjustment range: -100%~100%

(When the RTN button is touched for 1 second, the offset rate is reset to the initial value.)

*Maximum offset amount is near maximum slow.

*When a minus rate is input, offset is applied to the high side.

Touch the RTN button to end adjustment and return to the cursor move mode.

SWASH RING

Limits the swash plate travel to within a fixed range. (Helicopter only)

This function limits the swash travel to within a fixed range to prevent damaging of the swash linkage by simultaneous operation of the ailerons and elevators. It is effective in 3D aerobatics which use a large travel.

- Select [SWASH RING] at the linkage menu and call the setup screen shown below by touching the RTN button.
- Select the function name and return to the Linkage menu by touching the RTN button or pushing the Home/Exit button.
- When the swash ring function is activated, a circle is displayed in the operating range display area and the rate input box is displayed. Stick operation is limited to within the area of this circle.
- The operating range display area: The vertical direction shows the elevator travel. The horizontal direction shows the aileron travel.
- The marker shows the stick position.

Swash ring setting procedure

*Perform the following settings after using the touch sensor to move the cursor to the item you want to set.

1. Activate the function:

Move the cursor to the [ACT/INH] item and touch the RTN button to switch to the data input mode.

Switch the blinking from "INH" to "ACT" by turning the touch sensor to the left and then touch the RTN button.

2. Rate setting:

Use the touch sensor to move the cursor to the [RATE] item touch the RTN button to switch to the data input mode.

Use the touch sensor to set the rate.

Initial value: 100%.

Adjustment range: 50% to 200%.

*Adjust the rate to maximum swash tilt.

(When the RTN button is touched for 1 second, the rate is reset to the initial value.)

Touch the RTN button to end adjustment and return to the cursol move mode.

SWASH

Swash operation linkage correction function.(helicopter only, except swash type H-1)

Neutral Point

At your linkages, if the servo horn deviates from a perpendicular position at neutral, the linkage compensation functions in this menu may not compensate effectively. To correct this use the neutral point function. This will move the neutral point of the servos to the actual perpendicular position. However, this adjustment changes only the axis point of the compensation functions in this menu, and does not affect the neutral position of other functions.

Swash AFR

Swash AFR function reduces/increases/reverses the rate (travel) of the aileron, elevator and collective pitch functions, by adjusting or reversing the motion of all servos involved in that function, only when using that function.

- Select [SWASH] at the linkage menu and call the setup screen shown below by touching the RTN button.

- Select the function name and return to the Linkage menu by touching the RTN button or pushing the Home/Exit button.

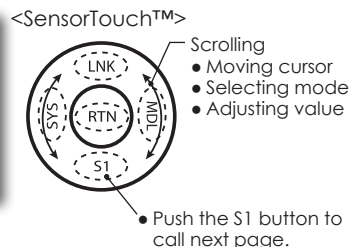
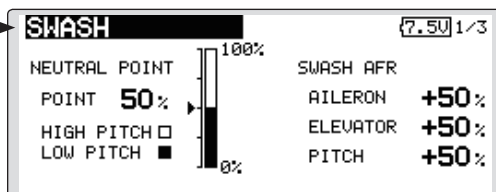

*Before making the following settings, use the touch sensor to move the cursor to the item you want to set.

Neutral point setting procedure

The neutral point becomes the correction standard point.

*Adjusting the servo horn so that the neutral point is near the 50% position makes the mixing amount small.

1. Neutral point setting

Move the cursor to the [POINT] item and hold the pitch operation so that the servo horn is at a right angle to the linkage rod and touch the RTN button for 1 second and read the neutral position.

*The neutral point can also be displayed by bar graph.

After reading the neutral point, use the other correction functions to make further adjustments.

Mixing Rate

This compensation mixing is used to correct the tendency of the swash-plate for each control. The following compensation mixing is possible; PIT to AIL, PIT to ELE, AIL to PIT, ELE to AIL, and ELE to PIT (HR3 mode.) It adjusts the swash-plate to operate correctly for each control using the corresponding compensation mixing.

Linkage Compensation

This compensation mixing is used to correct the tendency of the swash-plate for pitch control at low pitch and high pitch.

Speed Compensation

This function is used to cancel the reaction that is generated by the difference of the operation amount of each servo when the swash-plate moves.

Swash AFR setting procedure

The swash AFR function makes adjustments so that the servos travel the specified amount by [AILERON], [ELEVATOR], and [PITCH] operation.

1. Use the touch sensor to move the cursor to the function you want to adjust and touch the RTN button to switch to the data input mode.

2. Adjust the AFR rate by turning the touch sensor to the left or right.

Initial value: +50%

Adjustment range: -100%~+100%

(When the RTN button is touched for 1 second, the AFR rate is reset to the initial value.)

Touch the RTN button to end adjustment and return to the cursor move mode.

Mixing rate setting procedure

The HR-3 is taken as an example to describe mixing rate setting. Mixing applied in other swash modes is different, but the setting procedure is the same.

SWASH		(7.50) 2/3	
MIXING RATE			
MIXING	←+↻ ↻+→	MIXING	←+↻ ↻+→
PIT→AIL	100% 100%	AIL→PIT	100% 100%
PIT→ELE	100% 100%	ELE→AIL	50% 50%
		ELE→PIT	50% 50%

*Set the throttle stick to the preset neutral point. Adjust the length of the linkage rod so that the swash plate is horizontal at this position.

*The sub trim function can be used to make small adjustments.

*Adjust so that the pitch curve is a straight line and pitch operation is maximum.

*When making the following setting, use the touch sensor to move the cursor to the item you want to set and touch the RTN button to switch to the data input mode. Touch the RTN button to end adjustment and return to the cursor move mode.

1. Adjustment at aileron operation [AIL to PIT]

Adjust the AIL to PIT rate so there is no interference in the elevator or pitch direction when the aileron stick is moved to the left and right.

*Adjust by turning the touch sensor to the left or right.

*The left and right sides can be adjusted individually.

2. Adjustment at elevator operation [ELE to AIL]/[ELE to PIT]

Adjust the ELE to AIL and ELE to PIT rates so there is no interference in the aileron or pitch direction when the elevator stick is moved up and down.

*Adjust by turning the touch sensor to the left and right.

*The up and down sides can be adjusted individually.

3. Adjustment at pitch operation [PIT to AIL][PIT to ELE]

Adjust the PIT to AIL and PIT to ELE rates so that the swash plate moves to the horizontal position when the throttle stick was moved to maximum slow and full high.

*Adjust by turning the touch sensor to the left and right.

*The slow and high sides can be adjusted individually.

Linkage compensation setting procedure

*Perform linkage compensation setting after mixing rate setting.

*Linkage compensation compensates for interference by aileron operation with the elevator or elevator operation with the aileron at collective pitch control for low pitch and high pitch.

SWASH		(8.80) 3/3	
LINKAGE COMPENSATION			
FUNCTION	DIR.	LOW PITCH	↻+→ ↻+→
AILERON	+	0%	0%
ELEVATOR	+	0%	0%
SPEED COMPENSATION			
0			

*When making the following setting, use the touch sensor to move the cursor to the item you want to set and touch the RTN button to switch to the data input mode. Touch the RTN button to end adjustment and return to the cursor move mode.

1. Compensation at aileron operation [AILERON]

Set the throttle to the maximum slow position. Move the aileron stick to the left and right and adjust the aileron compensation amount so that interference in the elevator or pitch direction at that time is minimum.

*Adjust the touch sensor to the left and right.

*The left and right sides can be adjusted individually.

*When the interference increases when the compensation amount was increased, make adjustments with the compensation direction [DIR] as "-".

2. Compensation at elevator operation [ELEVATOR]

Adjust the elevator compensation amount so that the aileron or pitch direction interference when the elevator stick was moved up and down is minimum.

3. Regarding steps 1 and 2 above, perform aileron and elevator compensation similarly at the full high side of the throttle stick also.

Speed compensation setting procedure

1. Use the touch sensor to move the cursor to the "SPEED COMPENSATION" item and touch the RTN button to switch to the data input mode.

2. Set the throttle stick to the neutral point position. Quickly move the elevator stick and adjust the speed compensation amount [SPEED COMPENSATION] for minimum interference in the pitch direction.

*Adjust by turning the touch sensor to the left and right.

Touch the RTN button to end adjustment and return to the cursor move mode.

The Timer function may be set for any desired time, i.e. engine run time, specified times for competitions, etc. Two independent timers are provided for your use. The timers are stored independently with each model, meaning that when you switch between model setups, the timer associated with the new model is brought up automatically.

The timers may be set to start and stop from the motion of any switch or stick. You may set the ON and OFF directions freely. Each timer has a capacity of up to 59 minutes 59 seconds.

Each timer may be set for count-down or count up operation with a target time.

If a target time is set and the timer reaches the set time, a buzzer sound for each count is generated.

Countdown timers sound one short beep during the last twenty seconds and two short beeps during the last ten seconds before reaching the target, then a long tone at the target time, and continue counting with displaying a minus (-) sign. Count-up timers also beep the last twenty and ten seconds, beep the target time, and keep counting upwards until shut down.

- Select [TIMER] at the linkage menu and call the setup screen shown below by touching the RTN button.

- Select the function name and return to the Linkage menu by touching the RTN button or pushing the Home/Exit button.

← Memory → ON

- The timer value is held even if the power is turned off or the model is switched.

Timer setting

*Perform the following settings after using the touch sensor to move the cursor to the item you want to set.

1. Up timer/down timer setting

Move the cursor to the [MODE] item and touch the RTN button to switch to the data input mode.

Select the mode by moving the touch sensor to the left or right and touch the RTN button.

[UP]: Up timer

[DOWN]: Down timer

2. Timer time setting

Move the cursor to the [10]:[100] item and touch the RTN button to switch to the data input mode.

Set the time by turning the touch sensor to the left or right.

[00]:[00]:[min]:[sec]

Touch the RTN button to end adjustment and

return to the cursor move mode.

3. Switch setting

Move the cursor to the item of the switch you want to set, call the switch setup screen by touching the RTN button, and select the switch and ON direction.

[For a detailed description of the setting method, see [Switch Setting Method] at the back of this manual.]

[RESET SW]: Reset switch

[START SW]: Start switch

[STOP SW]: Stop switch

Timer operation

- Timer 1 and Timer 2 are started/stopped by pre-selected start/stop switch.
- To reset a timer, operate the pre-selected reset switch, or move the cursor to the [RESET] display on the timer screen and touch the RTN button.

Alarm mode

*A mode which sounds an alarm every minute during the remaining time up to the timer alarm time.

1. Change the setting by pressing ↑ or ↓ button.

[↑]: An alarm sounds every minute of the elapsed time from timer start. (Conventional mode)

[↓]: An alarm sounds every minute of the remaining time up to the alarm time.

HOURL mode

*An HOURL mode counts up to 99 hours 50 minutes to the timer modes.

- This mode is convenient when used at engine maintenance period and other long term measurements.
- When the HOURL mode is set, "xx(hour) : xx(minute)" is displayed on the count time display. Seconds are not displayed.
- When the HOURL mode is set, " : " blinks each second during timer operation.
- When the HOURL mode is set, the alarm function/lap time measurement function are inhibited.

T1-T6 SETTING

Digital trim settings

This function adjusts the digital trim's control step amount and operation mode (T1~T6.)

When the flight conditions are set, the trim operation can be coupled with among all the conditions which combination mode is selected.

- Select [T1-T6 SETTING] at the linkage menu and call the setup screen shown below by touching the RTN button.

- Select the function name and return to the Linkage menu by touching the RTN button or pushing the Home/Exit button.

T1-T6 SETTING		NORMAL		[8.10] 1/1	
STEP	MODE	STEP	MODE		
T1	4 SEPAR	T4	4 SEPAR		
T2	4 SEPAR	T5	4 SEPAR		
T3	4 SEPAR	T6	4 SEPAR		

TRIM UNIT
 --

<SensorTouch™>

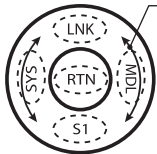

- Scrolling
- Moving cursor
- Selecting mode

Control step amount setting

- Use the touch sensor to move the cursor to the [STEP] item and touch the RTN button to switch to the data input mode.
Set the control step amount by turning the touch sensor.
Initial value: 4
Adjustment range: 1~200
(When the RTN button is touched for 1 second, the control step amount is reset to the initial value.)
*When the value is made large, the change per step becomes larger.
- Touch the RTN button to end adjustment and return to the cursor move mode.

Separate/combination mode selection

- Use the touch sensor to move the cursor to the [SEPA./COMB.] item and change to blinking by turning the touch sensor and select the mode by touching the RTN button.
[COMB]: Combination mode. The trim data are reflected at all the flight conditions.
[SEPAR]: Separate mode. Trim adjustment for each flight condition.

Trim display units

- Percentage(%) display can be selected at trim.
- Select "TRIM UNIT" and turn the dial and switch the display to [%] or [--].
*The display blinks.
[%]: Trim is displayed in % units.
[--]: Trim is displayed numerically as in the past.
 - When the RTN button touched, the setting is changed.

The system has compatible with the Futaba MPDX-1 multiprop decoder. One channel can be expanded to 8 channels by using the MPDX-1 multiprop decoder. Up to two MPDX-1 can be used.

*The trim step amount and trim rate are not reset.

- Select [MULTIPROP] at the linkage menu and call the setup screen shown below by touching the RTN button.

- Select the function name and return to the Linkage menu by touching the RTN button or pushing the Home/Exit button.

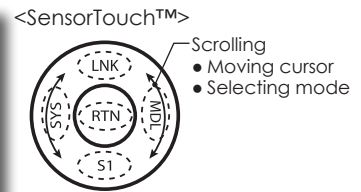

Multiprop selection

1. Select the Linkage Menu multiprop setting [MULTIPROP] and touch the RTN button.
2. The MULTIPROP setup screen is displayed.
3. Select [MP1] and touch the RTN button.
4. Scrolling the touch sensor and switch the display to [MP1] or [MP2].

*The display blinks.

[MP1]: Multiprop 1

[MP2]: Multiprop 2

5. Touch the RTN button.

Channel setting

1. Select [CH] and touch the RTN button. Scrolling the touch sensor and display the channel to which the MPDX-1 is connected.

*To turn off the multiprop function, set [--] at CH.

2. When the activated channel is selected and touch the RTN button, the multiprop setting contents are displayed.

Control setting

1. Select the "CONTROL" row of the multiprop channel whose control you want to set and touch the RTN button.
2. A hardware selection screen is displayed. Select the hardware which is to set control and touch the RTN button.

Servo reverse setting

1. Select the "REVERSE" row of the multiprop channel which is to be reversed and touch the RTN button.
2. Scrolling the touch sensor and switch the display to [NORM] or [REV].

*The display blinks.

[NORM]: Normal mode

[REV]: Reverse mode

3. Touch the RTN button.

End Point Setting

1. Select the "← ↑" row or "↓ →" row of the multiprop channel whose end point is to be set and switch to the data input mode by touch the RTN button.
2. Adjust the end point by scrolling the touch sensor .
Initial value : 100%
Adjustment range : 30-100%
3. After adjustment, touch the RTN button.

FUNCTION NAME

Function name can be changed

The name of the spare functions (AUXILIARY1-8) can be changed for the full name (10 characters) or for the abbreviated name (4 characters).

- Select [FUNCTION NAME] at the linkage menu and call the setup screen shown below by touching the RTN button.

• Select the function name and return to the Linkage menu by touching the RTN button or pushing the Home/Exit button.

Function name change method

1. Select [FUNCTION NAME] of the Linkage Menu and touch the RTN button.
2. The FUNCTION NAME setup screen is displayed.
3. When the function whose name is to be changed is selected and the RTN button is touched, a modification screen is displayed.
4. Select the function to be renamed and select [RENAME] and touch the RTN button. A character input screen is displayed. Input the function name.

6. The function name may be displayed in 10 characters or 4 characters, depending on the setup screen. For 4 characters, display, input the function name as required.

5. When [RESET] is selected and the RTN button is held down, the function name is set to the initial state function name.

TELEMETRY

Displaying data from the receiver

This screen displays your choice of data from the receiver.

Also warnings can be activated regarding other data from your aircraft. For example, if the receiver voltage drops, the user can be warned by an alarm (and vibration).

- *It cannot be used in FASST mode and S-FHSS mode.
- *Only receiver voltage and EXT voltage can be used in FASSTest12CH mode.
- *The FASSTest18CH mode can use all the telemetry functions.

- Select [TELEMETRY] in the Linkage menu and access the setup screen shown below by touching the RTN button.

- Receiver → Transmitter. The reception strength is shown.

- Select the function name and return to the Linkage menu by touching the RTN button or pushing the Home/Exit button.

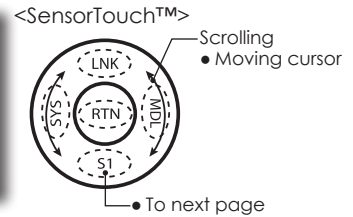
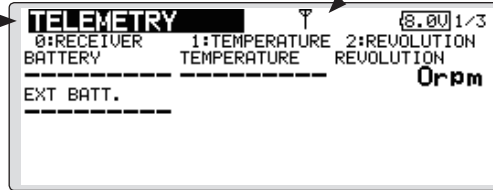

- Push S1 button to advance to next page.

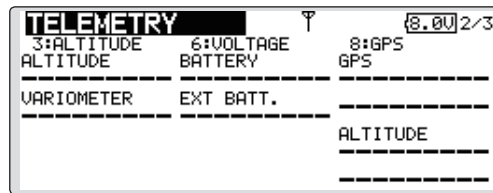

How to see telemetry data

1. Telemetry screen can be called select [TELEMETRY] in the Linkage menu and access the setup screen by touching the RTN button.
2. If each item is chosen and the RTN button is pushed, an alarm setup can be performed with the minimum/maximum after a transmitter is turned on.

*Receiver voltage can be checked immediately. An optional sensor will need to be attached to S.BUS2 of a receiver if you would like to see other information.

*No special setup is necessary if each sensor displayed is left as in the default setup. Separate sensor ID is also unnecessary. However, if two or more of one kind of sensor is used, setup is required in the "SENSOR" menu.

⚠ WARNING

- ⊘ Do not watch the transmitter screen during flight.

*You may lose sight of the aircraft during flight and this is extremely dangerous. Have an assistant on hand to check the screen for you. A pilot should NEVER take his eyes off his aircraft.

TELEMETRY : RECEIVER [BATTERY]

Displaying data from the receiver battery voltage

In this screen, the battery voltage of a receiver is displayed.

If it becomes higher or lower than the setting an alarm and/or vibration will alert you.

*It cannot be used in FASST mode and S-FHSS mode.

*Only receiver voltage and EXT voltage can be used in FASSTest12CH mode.

*The FASSTest18CH mode can use all the telemetry functions.

- Select [Rx-BATT.] in the TELEMETRY screen and access the setup screen shown below by touching the RTN button.
- Select the function name and return to the Linkage menu by touching the RTN button or pushing the Home/Exit button.
- The "down" arrow will indicate that an alarm will sound when the voltage drops to below the setting.
- ALARM is chosen from BUZZER, VOICE, and INHIBIT.
- The ON/OFF switch of SPEECH is chosen.

- Receiver battery voltage
- The maximum and the minimum when powering ON are shown. It will be preset, if a cursor is moved to this place and the RTN button is pushed for 1 second.
- Select [BATTERY] in the RECEIVER screen and access the setup screen shown below by touching the RTN button.
- A setup of the voltage on which the alarm operates.

Alarm set

1. Move the cursor to the ↓ALARM item, and it chooses from BUZZER, VOICE, INHIBIT, and pushes RTN.
 2. When not operating vibrator, it is "VIBRATOR" to INHIBIT. TYPE1-3 will be chosen if it is made to operate.
 3. Move the cursor to the LIMIT [4.0V] item and touch the RTN button to switch to the data input mode.
 4. Adjust the rate by scrolling the touch sensor.
Initial value: 4.0V
Adjustment range: 0.0V~100.0V
- *When the RTN button is touched for one second, the rate is reset to the initial value.
5. Touch the RTN button. (To terminate the input and return to the original state, touch the Home/Exit button.)

"VIBRATOR" type

If the following types are selected, the transmitter will vibrate during the warning.

TYPE 1		—————→
TYPE 2		————→
TYPE 3		→ → → →

TELEMETRY : RECEIVER [EXT BATT.]

Displaying data from the EXT battery voltage port

The EXT-VOLT screen will display the data from the EXT-battery output from the R7008SB receiver. In order to use this function, it is necessary to connect external voltage connector of the R7008SB receiver to a CA-RVIN-700 (FUTM5551) or SBS-01V to the battery you desire to measure the voltage of the EXT-battery.

*CA-RVIN-700 must be installed in the aircraft.

You will be alerted by an alarm or vibration if the voltage set by you is exceeded.

*It cannot be used in FASST mode and S-FHSS mode.

*Only receiver voltage and EXT voltage will be received in the FASSTest12CH mode.

*The FASSTest18CH mode will display all telemetry data.

- Select [Rx-BATT.] in the TELEMETRY screen and access the setup screen shown below by touching the RTN button.
- Select the function name and return to the Linkage menu by touching the RTN button or pushing the Home/Exit button.
- EXT battery voltage
- The maximum and the minimum when powering ON are shown. It will be preset, if a cursor is moved to this place and the RTN button is pushed for 1 second.
- Select [EXT BATT.] in the RECEIVER screen and access the setup screen shown below by touching the RTN button.
- A setup of the voltage on which the alarm operates.
- ALARM is chosen from BUZZER, VOICE, and INHIBIT.
- The ON/OFF switch of SPEECH is chosen.

Alarm set

1. Move the cursor to the ↓ALARM item, and it chooses from BUZZER, VOICE, and INHIBIT, and pushes RTN.
 2. When not operating vibrator, it is "VIBRATOR" to INHIBIT. TYPE1-3 will be chosen if it is made to operate.
 3. Move the cursor to the LIMIT [4.0V] item and touch the RTN button to switch to the data input mode.
 4. Adjust the rate by scrolling the touch sensor.
Initial value: 4.0V
Adjustment range: 0.0V~100.0V
- *When the RTN button is touched for one second, the rate is reset to the initial value.
5. Touch the RTN button. (To terminate the input and return to the original state, touch the Home/Exit button.)

"VIBRATOR" type

If the following types are selected, the transmitter will vibrate during the warning.

TYPE 1		→
TYPE 2		→ →
TYPE 3		→ → → →

TELEMETRY : TEMPERATURE

Displaying data from the temperature

***A temperature sensor must be installed in the aircraft.**

Temperature is a screen which displays/sets up the temperature information from an optional temperature sensor.

The temperature of the model (engine, motor, battery, etc.) which is flying can be displayed.

If it becomes higher or lower than the setting an alarm and/or vibration will alert you.

- *It cannot be used in FASST mode and S-FHSS mode.
- *Only receiver voltage and EXT voltage can be used in FASSTest12CH mode.
- *The FASSTest18CH mode can use all the telemetry functions.

- The maximum and the minimum when powering ON are shown. It will be preset, if a cursor is moved to this place and the RTN button is pushed for 1 second.

- Select [TEMPERATURE] in the TELEMETRY screen and access the setup screen shown below by touching the RTN button.

- Select the function name and return to the Linkage menu by touching the RTN button or pushing the Home/Exit button.

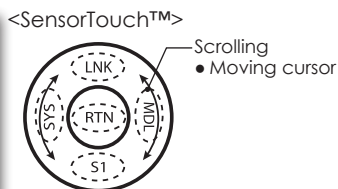
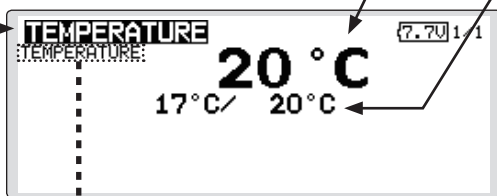

- Select [TEMPERATURE] (small font display) in the TEMPERATURE screen and access the setup screen shown below by touching the RTN button.

- A setup of the temperature on which the alarm operates.

- ↑ An upward arrow will show that an alarm will sound when the temperature rises above the set value.
- ↓ A downward arrow will show that an alarm will sound when the temperature drops below the set value.

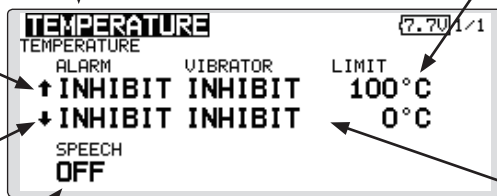

- The ON/OFF switch of SPEECH is chosen.

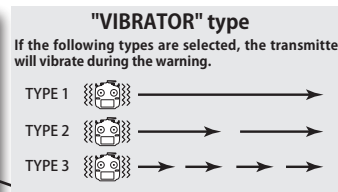

Alert set : Hot warning

1. Move the cursor to the ↑ALARM item, and it chooses from BUZZER, VOICE, INHIBIT, and pushes RTN.
2. When not operating vibrator, it is "VIBRATOR" to INHIBIT. TYPE1-3 will be chosen if it is made to operate.
3. Move the cursor to the LIMIT [°C] item and touch the RTN button to switch to the data input mode.
4. Adjust the rate by scrolling the touch sensor. Initial value: 100°C Adjustment range: 0°C ~200°C (↑LIMIT ≥ ↓LIMIT)
- *When the RTN button is touched for one second, the rate is reset to the initial value.
5. Touch the RTN button. (To terminate the input and return to the original state, touch the Home/Exit button.)

Alert set : Low-temperature warning

1. Move the cursor to the ↓ALARM item, and it chooses from BUZZER, VOICE, INHIBIT, and pushes RTN.
2. When not operating vibrator, it is "VIBRATOR" to INHIBIT. TYPE1-3 will be chosen if it is made to operate.
3. Move the cursor to the LIMIT [°C] item and touch the RTN button to switch to the data input mode.
4. Adjust the rate by scrolling the touch sensor. Initial value: 0°C Adjustment range: 0°C ~200°C (↑LIMIT ≥ ↓LIMIT)
- *When the RTN button is touched for one second, the rate is reset to the initial value.
5. Touch the RTN button. (To terminate the input and return to the original state, touch the Home/Exit button.)

TELEMETRY : RPM SENSOR

Displaying data from the RPM

RPM sensor is a screen which displays / sets up the rotation information from an optional RPM sensor.

The rotation of the model (engine, motor, etc.) which is flying can be shown.

If it becomes higher or lower than the setting an

- Select [RPM sensor] in the TELEMETRY screen and access the setup screen shown below by touching the RTN button.

- Select the function name and return to the Linkage menu by touching the RTN button or pushing the Home/Exit button.

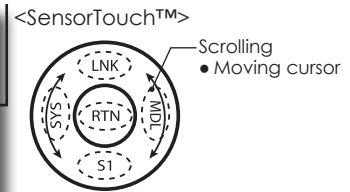
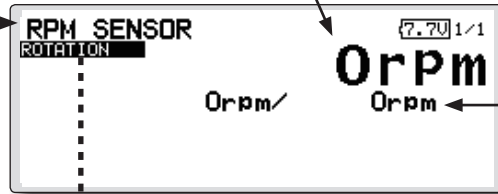

- Select [ROTATION] (small font display) in the RPM sensor screen and access the setup screen shown below by touching the RTN button.

- A setup of the revolution on which the alarm operates.

- ↑ An upward arrow indicates that the alarm will sound when the RPM rises above the set value.
- ↓ A downward arrow indicates that the alarm will sound when the RPM falls below the set value.

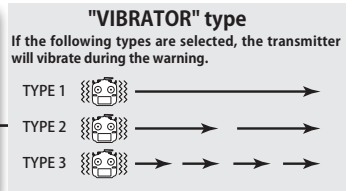
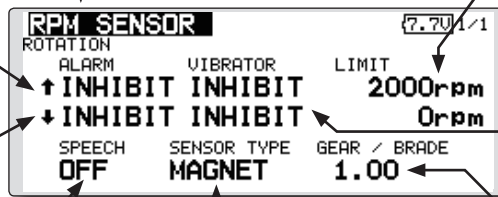

- The ON/OFF switch of SPEECH is chosen.

- "MAGNET" or "OPTICS" is set according to the sensor you use.
SBS-01RM : MAGNET
SBS-01RO : OPTICS

- In "MAGNET", the gear ratio of your engine (motor) you are using is entered.
- In "OPTICS", the number of blades of the propeller (rotor) your model is entered.

*A RPM sensor must be installed in the aircraft. alarm and/or vibration will alert you.

*It cannot be used in FASST mode and S-FHSS mode.

*Only receiver voltage and EXT voltage can be used in FASSTest12CH mode.

*The FASSTest18CH mode can use all the telemetry functions.

- The maximum and the minimum when powering ON are shown. It will be preset, if a cursor is moved to this place and the RTN button is pushed for 1 second.

Alarm set : Over rotations

1. Move the cursor to the ↑ALARM item, and it chooses from BUZZER, VOICE, INHIBIT, and pushes RTN.
2. When not operating vibrator, it is "VIBRATOR" to INHIBIT. TYPE1-3 will be chosen if it is made to operate.
3. Move the cursor to the LIMIT [2,000rpm] item and touch the RTN button to switch to the data input mode.
4. Adjust the rate by scrolling the touch sensor.
Initial value: 2,000rpm
Adjustment range: 0rpm~150,000rpm
(↑LIMIT ≥ ↓LIMIT)

*When the RTN button is touched for one second, the rate is reset to the initial value.

5. Touch the RTN button. (To terminate the input and return to the original state, touch the Home/Exit button.)

Alarm set : Under rotations

1. Move the cursor to the ↓ALARM item, and it chooses from BUZZER, VOICE, INHIBIT, and pushes RTN.
2. When not operating vibrator, it is "VIBRATOR" to INHIBIT. TYPE1-3 will be chosen if it is made to operate.
3. Move the cursor to the LIMIT [0rpm] item and touch the RTN button to switch to the data input mode.
4. Adjust the rate by scrolling the touch sensor.
Initial value: 0rpm
Adjustment range: 0rpm~150,000rpm
(↑LIMIT ≥ ↓LIMIT)

*When the RTN button is touched for one second, the rate is reset to the initial value.

5. Touch the RTN button. (To terminate the input and return to the original state, touch the Home/Exit button.)

TELEMETRY : ALTITUDE

Displaying data from the altitude

***An altitude sensor or GPS sensor must be installed in the aircraft.**

ALTITUDE is a screen which displays / sets up the altitude information from an optional altitude sensor or GPS sensor. The altitude of the model which is flying can be known. If it becomes higher (low) than preset altitude, you can be told by alarm. To show warning by vibration can also be chosen. Data when a power supply is turned on shall be 0 m, and it displays the altitude which changed from there. Even if the altitude of an airfield is high, that shall be 0 m and the altitude difference from an airfield is displayed.

This sensor calculates the altitude from atmospheric pressure. Atmospheric pressure will get lower as you go up in altitude, using this the sensor will estimate the altitude. Please understand that an exact advanced display cannot be performed if atmospheric pressure changes in a weather situation.

*It cannot be used in FASST mode and S-FHSS mode.

*Only receiver voltage and EXT voltage can be used in FASSTest12CH mode.

*The FASSTest18CH mode can use all the telemetry functions.

- Select [ALTITUDE] in the TELEMETRY screen and access the setup screen shown below by touching the RTN button.

- The maximum and the minimum when powering ON are shown. It will be preset, if a cursor is moved to this place and the RTN button is pushed for 1 second.

- Select the function name and return to the Linkage menu by touching the RTN button or pushing the Home/Exit button.

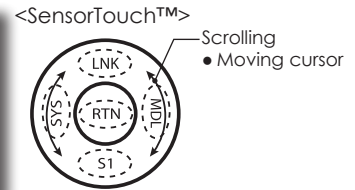
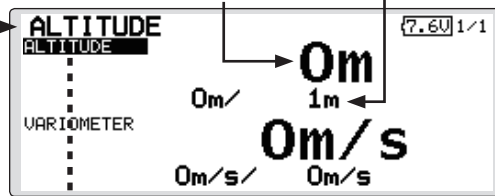

- ↑ An upward arrow indicates the alarm will sound when the altitude reaches above your set value.

- Select [ALTITUDE] (small font display) in the TEMPERATURE screen and access the setup screen shown below by touching the RTN button.

- ↓ A downward arrow indicates the alarm will sound when the altitude reaches below your set value.

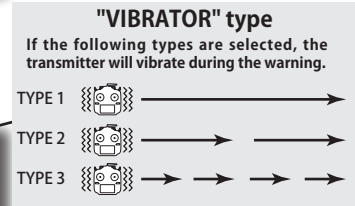
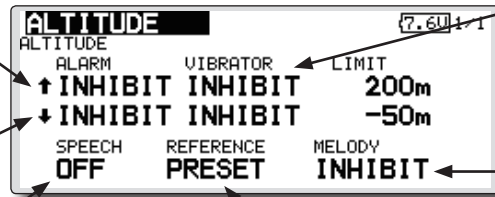

• If this is set to [MODE1-4], a rise and dive are told by a different melody.

MODE1: Little rise/dive → Melody changes (sensibly)
 ...
 MODE4: Big rise/dive → Melody changes (insensible)

• The ON/OFF switch of SPEECH is chosen.

First, the set of a reference is required.

1. The model and transmitter to which the altitude sensor was connected are turned on.
2. Move the cursor to the [PRESET] of "REFERENCE" item.
3. Touch the RTN button is pushed for 1 second. (To terminate the input and return to the original state, touch the Home/Exit button.)

*Atmospheric pressure is changed according to the weather also at the same airfield. You should preset before a flight.

Alarm set : High side

1. Move the cursor to the ↑ALARM item, and it chooses from BUZZER, VOICE, INHIBIT, and pushes RTN.
2. When not operating vibrator, it is "VIBRATOR" to INHIBIT. TYPE1-3 will be chosen if it is made to operate.
3. Move the cursor to the LIMIT [m] item and touch the RTN button to switch to the data input mode.
4. Adjust the rate by scrolling the touch sensor. Initial value: 200m Adjustment range-500m~+3,000m (↑LIMIT ≥ ↓LIMIT)

*When the RTN button is touched for one second, the rate is reset to the initial value.

5. Touch the RTN button. (To terminate the input and return to the original state, touch the Home/Exit button.)

Alarm set : Low side

1. Move the cursor to the ↓ALARM item, and it chooses from BUZZER, VOICE, INHIBIT, and pushes RTN.
2. When not operating vibrator, it is "VIBRATOR" to INHIBIT. TYPE1-3 will be chosen if it is made to operate.
3. Move the cursor to the LIMIT [m] item and touch the RTN button to switch to the data input mode.
4. Adjust the rate by scrolling the touch sensor. Initial value: -50m Adjustment range-500m~+3,000m (↑LIMIT ≥ ↓LIMIT)
- *When the RTN button is touched for one second, the rate is reset to the initial value.
5. Touch the RTN button. (To terminate the input and return to the original state, touch the Home/Exit button.)

TELEMETRY : ALTITUDE [VARIOMETER] Displaying data from the variometer

***An altitude sensor or GPS sensor must be installed in the aircraft.**

VARIO is a screen which displays / sets up the variometer information from an optional altitude sensor or GPS sensor.

The variometer of the model which is flying can be known.

If it becomes higher or lower than the setting an alarm and/or vibration will alert you.

To ensure that the pilot is aware as to the model's status, the T18SZ incorporates a different melody

for ascent and descent. Additionally, depending upon the rate of climb or descent, the tones vary to indicate whether or not the airplane is climbing or descending at a rapid rate.

*It cannot be used in FASST mode and S-FHSS mode.

*Only receiver voltage and EXT voltage can be used in FASSTest12CH mode.

*The FASSTest18CH mode can use all the telemetry functions.

- Select [ALTITUDE] in the TELEMETRY screen and access the setup screen shown below by touching the RTN button.

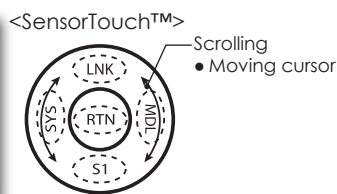
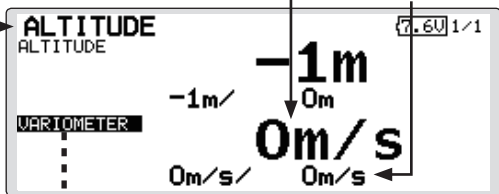

- Select the function name and return to the Linkage menu by touching the RTN button or pushing the Home/Exit button.

- Select [VARIOMETER] (small font display) in the TEMPERATURE screen and access the setup screen shown below by touching the RTN button.

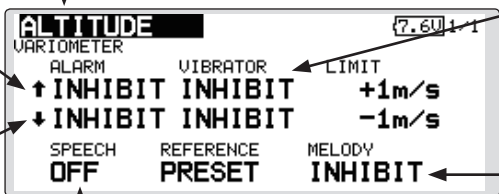

"VIBRATOR" type

If the following types are selected, the transmitter will vibrate during the warning.

TYPE 1		→
TYPE 2		→
TYPE 3		→

- ↑ An upward arrow indicates the alarm will sound when the variometer reaches above your set value.
- ↓ A downward arrow indicates the alarm will sound when the variometer reaches below your set value.

- The ON/OFF switch of SPEECH is chosen.

- If this is set to [MODE1-4], a rise and dive are told by a different melody.

MODE1: Little rise/dive → Melody changes (sensibly)
 ...
 MODE4: Big rise/dive → Melody changes (insensible)

Alert set : Rise side

1. Move the cursor to the ↑ALARM item, and it chooses from BUZZER, VOICE, INHIBIT, and pushes RTN.
2. When not operating vibrator, it is "VIBRATOR" to INHIBIT. TYPE1-3 will be chosen if it is made to operate.
3. Move the cursor to the LIMIT [m/s] item and touch the RTN button to switch to the data input mode.
4. Adjust the rate by scrolling the touch sensor.
 Initial value: +1m
 Adjustment range -50m/s~+50m/s
 (↑LIMIT ≥ ↓LIMIT)

*When the RTN button is touched for one second, the rate is reset to the initial value.

5. Touch the RTN button. (To terminate the input and return to the original state, touch the Home/Exit button.)

Alert set : Dive side

1. Move the cursor to the ↓ALARM item, and it chooses from BUZZER, VOICE, INHIBIT, and pushes RTN.
2. When not operating vibrator, it is "VIBRATOR" to INHIBIT. TYPE1-3 will be chosen if it is made to operate.
3. Move the cursor to the LIMIT [m/s] item and touch the RTN button to switch to the data input mode.
4. Adjust the rate by scrolling the touch sensor.
 Initial value: -1m
 Adjustment range -50m/s~+50m/s
 (↑LIMIT ≥ ↓LIMIT)

*When the RTN button is touched for one second, the rate is reset to the initial value.

5. Touch the RTN button. (To terminate the input and return to the original state, touch the Home/Exit button.)

TELEMETRY : VOLTAGE [BATTERY]

Displaying data from the battery voltage

*SBS-01V must be installed in the aircraft.

*It cannot be used in FASST mode and S-FHSS mode.

*Only receiver voltage and EXT voltage can be used in FASSTest12CH mode.

*The FASSTest18CH mode can use all the telemetry functions.

In this screen, the battery voltage is displayed. In order to use this function, it is necessary to connect External voltage connector of R7008SB ⇔ SBS-01V ⇔ Battery

SBS-01V measures two batteries. The power battery connected to two lines is displayed on EXT-VOLT. The battery for receivers connected to 3P lines is displayed here.

• Select [VOLTAGE] in the TELEMETRY screen and access the setup screen shown below by touching the RTN button.

• Select the function name and return to the Linkage menu by touching the RTN button or pushing the Home/Exit button.

• The "down" arrow will indicate that an alarm will sound when the voltage drops to below the setting.

• Select [BATTERY] in the VOLTAGE screen and access the setup screen shown below by touching the RTN button.

• A setup of the voltage on which the alarm operates.

• ALARM is chosen from BUZZER, VOICE, and INHIBIT.

• The ON/OFF switch of SPEECH is chosen.

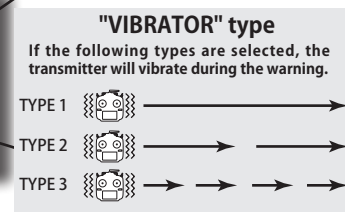
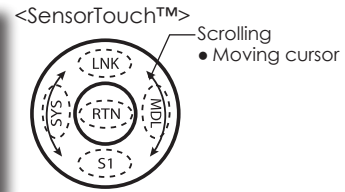
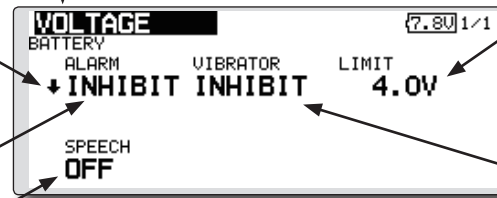
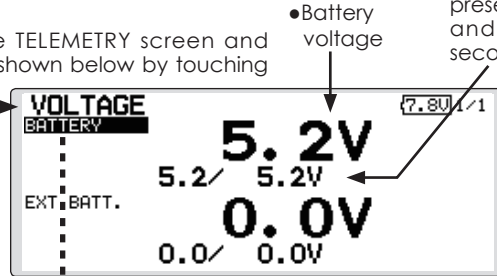

Alarm set

1. Move the cursor to the ↓ALARM item, and it chooses from BUZZER, VOICE, INHIBIT, and pushes RTN.
2. When not operating vibrator, it is "VIBRATOR" to INHIBIT. TYPE1-3 will be chosen if it is made to operate.
3. Move the cursor to the LIMIT [4.0V] item and touch the RTN button to switch to the data input mode.
4. Adjust the rate by scrolling the touch sensor.
Initial value: 4.0V
Adjustment range: 0.0V~100.0V
5. Touch the RTN button. (To terminate the input and return to the original state, touch the Home/Exit button.)

*When the RTN button is touched for one second, the rate is reset to the initial value.

< Two examples of wiring are shown >

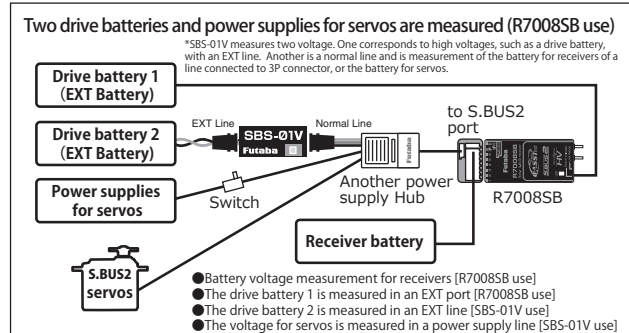
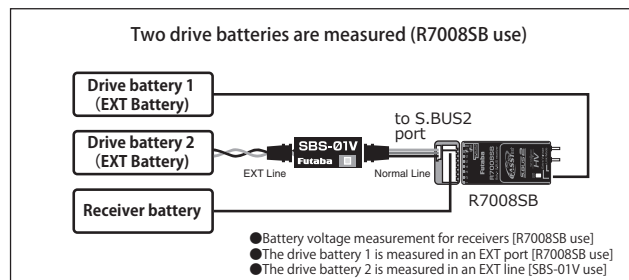

*Refer to the manual of SBS-01V for the details of wiring.

TELEMETRY : VOLTAGE [EXT-VOLT] Displaying data from the EXT battery voltage port

In this screen, the EXT battery voltage is displayed. In order to use this function, it is necessary to connect External voltage connector of R7008SB ⇔ SBS-01V ⇔ Battery

SBS-01V measures two batteries. The power battery connected to two lines is displayed on EXT-VOLT.

***SBS-01V must be installed in the aircraft.**

*It cannot be used in FASST mode and S-FHSS mode.

*Only receiver voltage and EXT voltage will be received in the FASSTest12CH mode.

*The FASSTest18CH mode will display all telemetry data.

- Select [VOLTAGE] in the TELEMETRY screen and access the setup screen shown below by touching the RTN button.
- Select the function name and return to the Linkage menu by touching the RTN button or pushing the Home/Exit button.
- The "down" arrow will indicate that an alarm will sound when the voltage drops to below the setting.
- ALARM is chosen from BUZZER, VOICE, and INHIBIT.
- The ON/OFF switch of SPEECH is chosen.

• EXT battery voltage

<SensorTouch™>
• Scrolling
• Moving cursor

- The maximum and the minimum when powering ON are shown. It will be preset, if a cursor is moved to this place and the RTN button is pushed for 1 second.
- Select [EXT BATT.] in the RECEIVER screen and access the setup screen shown below by touching the RTN button.
- A setup of the voltage on which the alarm operates.

Alarm set

1. Move the cursor to the ↓ALARM item, and it chooses from BUZZER, VOICE, and INHIBIT, and pushes RTN.
 2. When not operating vibrator, it is "VIBRATOR" to INHIBIT. TYPE1-3 will be chosen if it is made to operate.
 3. Move the cursor to the LIMIT [4.0V] item and touch the RTN button to switch to the data input mode.
 4. Adjust the rate by scrolling the touch sensor.
Initial value: 4.0V
Adjustment range: 0.0V~100.0V
- *When the RTN button is touched for one second, the rate is reset to the initial value.
5. Touch the RTN button. (To terminate the input and return to the original state, touch the Home/Exit button.)

"VIBRATOR" type
If the following types are selected, the transmitter will vibrate during the warning.

TYPE 1		→
TYPE 2		→ →
TYPE 3		→ → → →

TELEMETRY : GPS [DISTANCE]

Displaying data from the Distance Screen

***A GPS sensor must be installed in the aircraft.**

*The GPS sensor is necessary, and is sold separately. Mount and connect the sensor in accordance with the sensor instruction manual.

*It cannot be used in FASST mode and S-FHSS mode.

*Only receiver voltage and EXT voltage can be used in FASSTest12CH mode.

*The FASSTest18CH mode can use all the telemetry functions.

• This indicates the receiving accuracy from a GPS Satellite. When three bars are displayed, the GPS is ready for use.

• The maximum and the minimum when powering ON are shown. It will be preset, if a cursor is moved to this place and the RTN button is pushed for 1 second.

• Select [GPS] in the TELEMETRY screen and access the setup screen shown below by touching the RTN button.

• Select the function name and return to the Linkage menu by touching the RTN button or pushing the Home/Exit button.

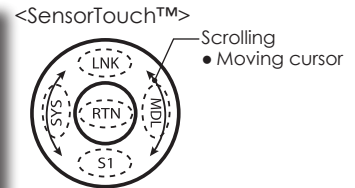
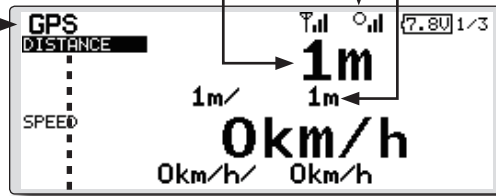

• Select [DISTANCE] (small font display) in the TEMPERATURE screen and access the setup screen shown below by touching the RTN button.

• ↑ An upward arrow indicates the alarm will sound when the distance reaches above your set value.

• ↓ A downward arrow indicates the alarm will sound when the distance reaches below your set value.

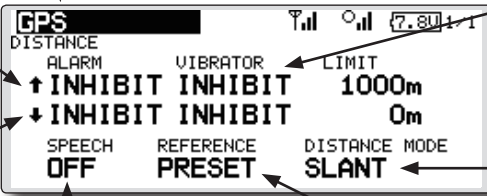

• The ON/OFF switch of SPEECH is chosen.

• Move the cursor to the [PRESET] of "REFERENCE" item. Touch the RTN button is pushed for 1 second. Sets the current aircraft position as the starting point.

"VIBRATOR" type
If the following types are selected, the transmitter will vibrate during the warning.

TYPE 1		→
TYPE 2		→
TYPE 3		→

*Positioning time of GPS



When powered up, the SBS-01G begins to acquire GPS satellite data. This process can take several minutes. Please do not move the model during this process. During acquisition, the LED on the SBS-01G will blink green; after the satellites signals have been acquired, the LED will become solid green, and the GPS signal strength display on the transmitter will show three bars.

Moving the model before the satellites are fully acquired will cause a delay in acquiring the satellite signal.

• Altitude calculated as either straight line distance (slant) or surface distance on a map can also be selected.

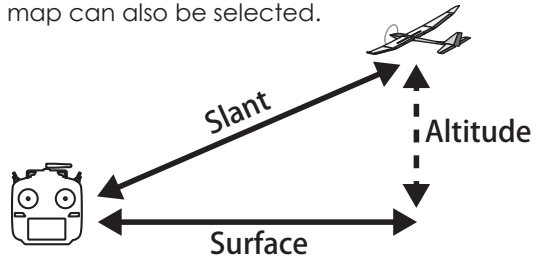

• Select <SLANT> <SURFACE> to "DISTANCE MODE", scroll either to the desired method and touch the RTN button.

First, the set of a reference is required.

1. The model and transmitter to which the GPS sensor was connected are turned on.
2. Move the cursor to the [PRESET] of "REFERENCE" item.
3. Touch the RTN button is pushed for 1 second. (To terminate the input and return to the original state, touch the Home/Exit button.)

*Now, the position of the present model was set to 0 m.

Setting a "too far" alarm distance

1. Move the cursor to the ↑ALARM item, and it chooses from BUZZER, VOICE, INHIBIT, and pushes RTN.
2. When not operating vibrator, it is "VIBRATOR" to INHIBIT. TYPE1-3 will be chosen if it is made to operate.
3. Move the cursor to the LIMIT [m] item and touch the RTN button to switch to the data input mode.
4. Adjust the rate by scrolling the touch sensor.
Initial value: 1,000m
Adjustment range 0m~3,000m
(↑LIMIT ≥ ↓LIMIT)

*When the RTN button is touched for one second, the rate is reset to the initial value.

5. Touch the RTN button. (To terminate the input and return to the original state, touch the Home/Exit button.)

Setting a "too close" alarm distance

1. Move the cursor to the ↓ALARM item, and it chooses from BUZZER, VOICE, INHIBIT, and pushes RTN.
 2. When not operating vibrator, it is "VIBRATOR" to INHIBIT. TYPE1-3 will be chosen if it is made to operate.
 3. Move the cursor to the LIMIT [m] item and touch the RTN button to switch to the data input mode.
 4. Adjust the rate by scrolling the touch sensor.
Initial value: 0m
Adjustment range 0m~3,000m
(↑LIMIT ≥ ↓LIMIT)
- *When the RTN button is touched for one second, the rate is reset to the initial value.
5. Touch the RTN button. (To terminate the input and return to the original state, touch the Home/Exit button.)

