

# SKYSPORT-6A

**Futaba**  
DIGITAL PROPORTIONAL  
RADIO CONTROL



## INSTRUCTION MANUAL

D60506

DA  
FP-6VA  
FM 6 CHANNEL  
AIRPLANE R/C SET

### FOREWORD

Thank you for selecting the Futaba SKYSPORT-6A. The SKYSPORT-6A is an easy-to-use digital proportional R/C set for all classes of R/C aircraft hobbyists, from beginners to advanced pilots. It has an outstanding array of functions needed by all classes of pilots.

To enjoy its functions to the fullest and to ensure safe flying, please read this manual carefully before using your set.

After reading this manual, store it in a safe place. If you encounter any difficulties while using your set, please refer to the appropriate sections in this manual.

In addition to this manual, please read all of the manuals included with your airplane, engine and other flight related equipment you may use.

To help ensure safe use, pay particular attention to the precautions printed throughout this manual and indicated by an exclamation mark .

### ATTENTION

#### 1. Application of Product

This product is not intended for use in any application other than for the control of models for hobby and recreational purposes. This product is subject to regulations of the Ministry of Radio/Telecommunications and is restricted under Japanese law to such purposes. The laws of other countries may similarly restrict the use of this product. Futaba is not responsible for any use that is not in compliance with applicable law.

#### 2. Exportation of Product

If the product is exported from Japan, the prior approval of the Ministry of Radio/Telecommunications is required regarding the country of destination. If this product is reexported from other countries, it may be subject to restrictions on such reexport and prior approval of government authorities may be required.

#### 3. Modification, Adjustment & Replacement of Parts

Futaba is not responsible for any use of this product that is not in compliance with applicable law and disclaims all responsibility for any modification or alteration of the product, including the incorporation of the product into other products by third parties, that is not in compliance with applicable law.

#### ATTENTION:

The product that you have purchased contains a rechargeable battery. The battery is recyclable. At the end of its useful life, under various state and local laws, it may be illegal to dispose of this battery into the municipal waste stream. Check with your local solid waste officials for details in your area for recycling options or proper disposal.



Ni-Cd





THE FOLLOWING STATEMENT APPLIES TO THE RECEIVER:  
THIS DEVICE COMPLIES WITH PART 15 OF THE FCC RULES. OPERATION IS SUBJECT TO THE FOLLOWING TWO CONDITIONS:  
(1) THIS DEVICE MAY NOT CAUSE HARMFUL INTERFERENCE, AND  
(2) THIS DEVICE MUST ACCEPT ANY INTERFERENCE RECEIVED, INCLUDING INTERFERENCE THAT MAY CAUSE UNDESIRABLE OPERATION.  
(For U.S.A.)

1. No part of this manual may be reproduced in any form without prior written permission.
2. The contents of this manual are subject to change without prior notice.
3. This manual has been carefully written, but please feel free to write to Futaba if you find that any corrections or clarifications that should be made.
4. Futaba is not responsible for the results of the use of this product by the customer.
5. Futaba and SKYSPORT are a registered trademark.

### PRECAUTIONS

To use your R/C set safely, please observe the following precautions:

#### (Operating precautions)

-  When powering up the system, first turn on the transmitter power, then turn on receiver power. When powering down the system, first turn off the receiver power, then turn off the transmitter power. If the power is turned on or off in the reverse order the control servos may move erratically causing engines or electric motors to race unexpectedly and possibly resulting in serious injury to the user or bystanders. Before turning on the power, set the throttle stick to the maximum slow position.
-  Extend the transmitter antenna to its full length. If the antenna is not extended fully, the transmitter output will drop and the range of receivable transmission will be shortened.
-  Never fly two or more models on the same frequency at the same time. Before flight, use a frequency monitor or other device to check that the frequency is not in use. Simultaneous flight on the same band is extremely dangerous because it will cause interference and loss of control. Differences in modulation method or signal format (AM, FM, PCM, etc.) does not mean that flights can be made on the same band.
-  Do not forget to recharge the Nicd battery before each flight. Needless to say, a dead battery will cause loss of control and a crash. Always check the discharge time on the ground and provide a margin of safety when determining the remaining flight time. When recharging the Nicd battery, observe the charging current and charging time specified on the battery. Charging the battery at a current and time exceeding the specified values will not only damage the battery by overcharging, but will also cause overheating and other dangerous conditions.

Do not fly on rainy days. Even in a drizzle, water can enter the transmitter through the antenna and sticks and cause faulty operation. The resulting loss of control may cause a crash or the engine to race and is very dangerous.

When placing the transmitter on the ground during flight preparations, make certain that the transmitter cannot be easily toppled by the wind or other means. If it tips over while the engine is running and the throttle stick is inadvertently moved to the high position as result, serious injury to the operator or others could result.

Always test your digital proportional R/C set before flight. As a simple test method, before starting the engine, retract the transmitter antenna fully and operate each servo from a distance of about 5m and check if the servos follow the movement of their control sticks. If a servo does not follow the movement of its control stick, extend the transmitter antenna to its full length, increase the distance on the ground, and repeat the test. If the receiving range is still short, discontinue flight and check the set.

### (Flying field)

In general, when a model is flown at high speed and / or the flying range is large, even more caution is necessary. A safe method is to fly at an exclusive flying field belonging to a club, etc. However, the presence of spectators, wind direction, etc. must be constantly monitored. In areas near high tension lines, high buildings, and communication facilities, consideration must be given not only to normal flight dangers, but also to possible loss of control caused by radio wave interference. Because R/C radio waves have a fairly long range, a location at least 3 km / 2 miles from other R/C flying fields and R/C control circuits is necessary.

### SET CONTENTS

Set name	SKYSPORT 6A 6DA	
Transmitter	FP-T6A 6DA	
Receiver	FP-R116FB, FP-R138DF, or FP-R127DF	
Servos	FP-S3003x4 or FP-S148x4	
Battery (Transmitter)	NT-8iB	_____
Battery (Receiver)	NR-4J	_____
Battery charger	x1	_____
Others	Receiver switch, Extension cord, Servo horns, Flat screwdriver	

### RATINGS

**Transmitter FP-T6A 6DA**  
 Operating system: Two-stick, 6 channels, w/airplane function  
 Transmitting frequency: 29, 35, 36, 40, 41, 50, 60 or 72MHz band  
 Modulation: FM (Frequency Modulation)  
 Power requirement: 9.6V Nicd battery(NT-8iB)  
 Current drain: 180mA

**Receiver FP-R116FB**  
 Receiving frequency: 29, 35, 36, 40, 41 or 60MHz band  
 Intermediate frequency: 455kHz  
 Power requirement: 4.8V or 6V Nicd battery (shared with servos)  
 Current drain: 22mA  
 Size: 33.4X50.4X20.5mm  
 Weight: 30g / 1.06oz

**Receiver FP-R138DF**  
 Receiving frequency: 35MHz band  
 Intermediate frequency: 1st IF 10.7MHz, 2nd IF 455kHz  
 Power requirement: 4.8V or 6V Nicd battery (shared with servos)  
 Current drain: 12mA  
 Size: 65X36X21.5mm  
 Weight: 39g / 1.38oz

**Receiver FP-R127DF**  
 Receiving frequency: 50 or 72MHz band  
 Intermediate frequency: 1st IF 10.7MHz, 2nd IF 455kHz  
 Power requirement: 4.8V or 6V Nicd battery (shared with servos)  
 Current drain: 10mA  
 Size: 64.3X35.8X21.0mm  
 Weight: 40.5g / 1.43oz

**Servo FP-S3001/FP-S148**  
 Control system: Pulse width control  
 Operating angle: One side 45 degree min. (including trim)  
 Power requirement: 4.8V or 6V Nicd battery (shared with receiver)  
 Current drain: 8mA (at idle)  
 Output torque: 3kg-cm / 42oz-in  
 Operating speed: 0.22 sec/60 degree  
 Size: 40.4x19.8x36mm  
 Weight: 45.1g / 1.59oz(S3001), 44.4g / 1.57oz(S148)

**Nicd battery NT-8iB**  
 Voltage: 9.6V  
 Capacity: 500mAh

**Nicd battery NR-4J**  
 Voltage: 4.8V  
 Capacity: 500mAh  
 Dimensions: 51x58x15mm  
 Weight: 95g / 3.35oz

### TRANSMITTER CONTROLS / OPERATION

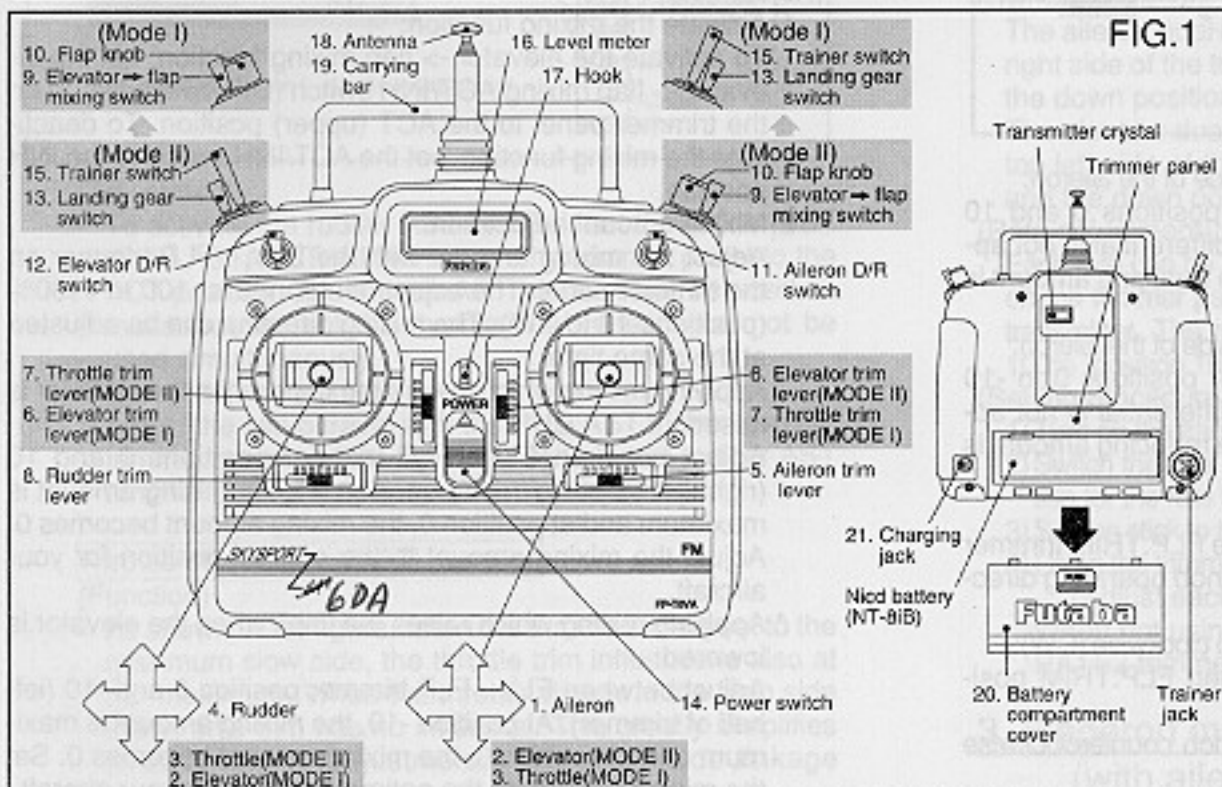

This section describes how to operate the transmitter. The numbers in the text correspond to the numbers in FIG.1. For a definition of special terms, see "GLOSSARY OF TERMS" on page 8.

### Servos operation

- Aileron
- Elevator
- Throttle
- Rudder

### Servos trimming

- Aileron trim lever
- Elevator trim lever
- Throttle trim lever with ATL
- Rudder trim lever

The throttle trim affects the throttle only when the throttle stick is in the low range (engine is at low speed). Linkage adjustment for the high range throttle (engine is at high speed) is simplified since the throttle trim only affects the low range of the throttle movement.

## Switches and knobs

9. **Elevator -> flap mixing switch (ELV -> FLP)**  
When this switch is pulled forward, the mixing function is turned on and the flaps are linked with elevator operation. However, this switch is effective only when elevator -> flap mixing is active (ACT).
10. **Flap knob (FLAP)**  
Normally, this knob is used as CH6. When flaperon mixing is active (ACT), this knob acts as the flap trimmer.
11. **Aileron dual rate switch (AILERON D/R)**  
This switch toggles the aileron servo travel (RATE1, RATE2). RATE1; upper position RATE2; down position
12. **Elevator dual rate switch (ELEVATOR D/R)**  
This switch toggles the elevator servo travel (RATE1, RATE2). RATE1; upper position RATE2; down position
13. **Landing gear switch (GEAR)**  
This switch activates the landing gear channel. (CH5 switch)
14. **Power switch**  
The transmitter is turned on when this switch is set to the upper position.
15. **Trainer switch (TRAINER)**  
This switch is turned on when set to the pulled forward position (spring-loaded type).

## Others

16. **Level meter**  
This meter indicates the transmitter power supply voltage. When the needle deflects to the boundary between the silver and red ranges, recharge the Nicd battery.
17. **Hook**  
Hook for neck strap.
18. **Antenna**  
When using the transmitter, extend the antenna to its full length.
19. **Carrying bar**  
Use this handle to carry the transmitter.
20. **Battery cover**  
Open this cover when adjusting the trimmers on the trimmer panel and when changing the Nicd battery.
21. **Charging jack**  
This is the transmitter Nicd battery charging jack.

## (Charging the Nicd battery)

- Never try to charge a dry cell battery. It will cause the battery to overheat or explode and is very dangerous.
- Always charge the Nicd battery before using your R/C set.

Connect the charger's transmitter and receiver connectors to the transmitter charging jack and receiver servo Nicd battery as shown in the figure (FIG.2). The charging LEDs light to show that the battery is being charged.

\* The normal charging time is about 15 hours. When you have not used your R/C set for some time, repeatedly charge and discharge the batteries two or three times before use.

\* The transmitter and receiver Nicd batteries can be charged simultaneously or independently.

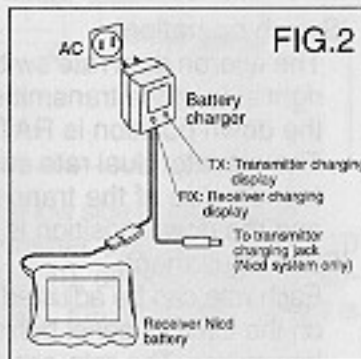

## (Non-slip adjustable lever head)

The length of the lever head of the sticks can be adjusted as desired. Adjust the stick length to fit your hand. (FIG.3)

- 1) Unlock lever heads A and B by turning them in the directions shown by the arrows.

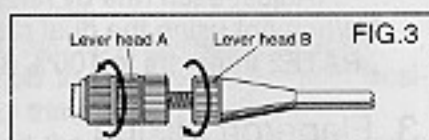

- 2) Adjust the stick to the most comfortable length and lock it by turning head B in the directions opposite that shown by the arrow.

## (Stick lever spring tension adjustment)

The stick lever spring tension can be adjusted by removing the transmitter back cover and turning the screw for each stick as shown in the figure (FIG.4). Adjust the spring tension for the best stick feel. When adjusting the stick spring, set the throttle stick to the center.

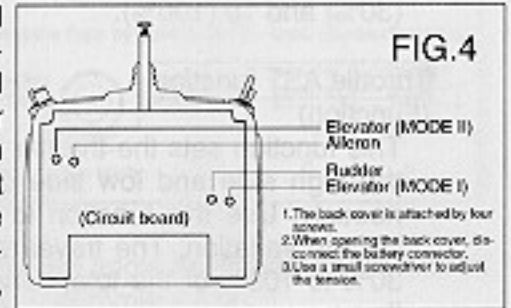

## (Trimmer panel)

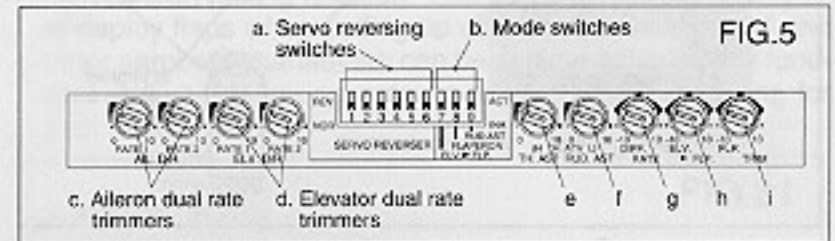

- a. **Servo reversing switch (SERVO REVERSER)**  
The servo reversing switches reverse the direction of travel of the servos. The lower position is the normal position. (Channels 1 to 6) (DIP switch Nos. 1 to 6)
- b. **Mode switches**
  1. **Elevator -> flap mixing ACT/INH switch**  
To activate the mixing function, set this switch to the ACT (upper) position. To deactivate the mixing function, set this switch to the INH (lower) position. (DIP switch No. 7)
  2. **Flaperon mixing ACT/INH switch**  
To activate the mixing function, set this switch to the ACT (upper) position. To deactivate the mixing function, set this switch to the INH (lower) position. (DIP switch No. 8)
  3. **Rudder AST function ACT/INH switch**  
To activate the rudder and throttle AST functions, set this switch to the ACT (upper) position. The throttle ATV function can be activated by setting this function to the INH (lower) position. Select the desired function.
- c. **Aileron dual rate trimmer (AIL D/R)**  
This trimmer sets the rate corresponding to both directions of the aileron dual rate switch. (RATE1, RATE2)  
When it is turned clockwise, the servo travel increases.
- d. **Elevator dual rate trimmer (ELV D/R)**  
This trimmer sets the rate corresponding to both directions of the elevator dual rate switch. (RATE1, RATE2)  
When it is turned clockwise, the servo travel increases.
- e. **Throttle AST trimmer (TH.AST) or throttle ATV trimmer (TH.ATV) H side**  
This trimmer adjusts the servo travel of the selected function. When it is turned clockwise, the servo travel increases.
- f. **Rudder AST trimmer (RUD.AST) or throttle ATV trimmer (TH.ATV) L side**  
This trimmer adjusts the servo travel of the selected function. When it is turned clockwise, the servo travel increases.
- g. **Aileron differential trimmer (DIFF.RATE)**  
This trimmer adjusts the aileron differential amount when the flaperon mixing function is active.
- h. **Elevator -> flap mixing trimmer (ELV->FLP)**  
This trimmer adjusts the mixing operation direction and amount.
- i. **Flap trimming function trimmer (FLP.TRIM)**  
This trimmer adjusts the flap trimming operation direction and variation width when the flaperon mixing function is active.

## CONNECTION OF RECEIVER, SERVOS, ETC.

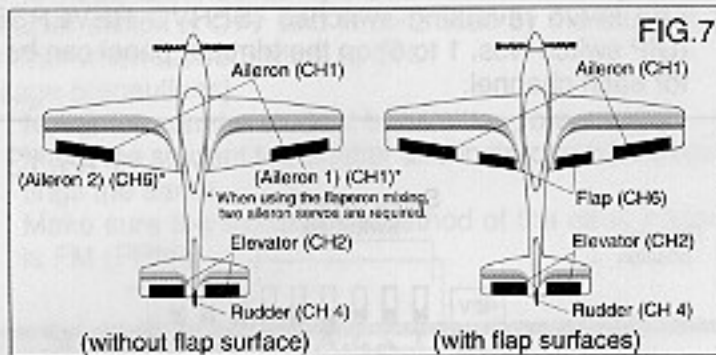
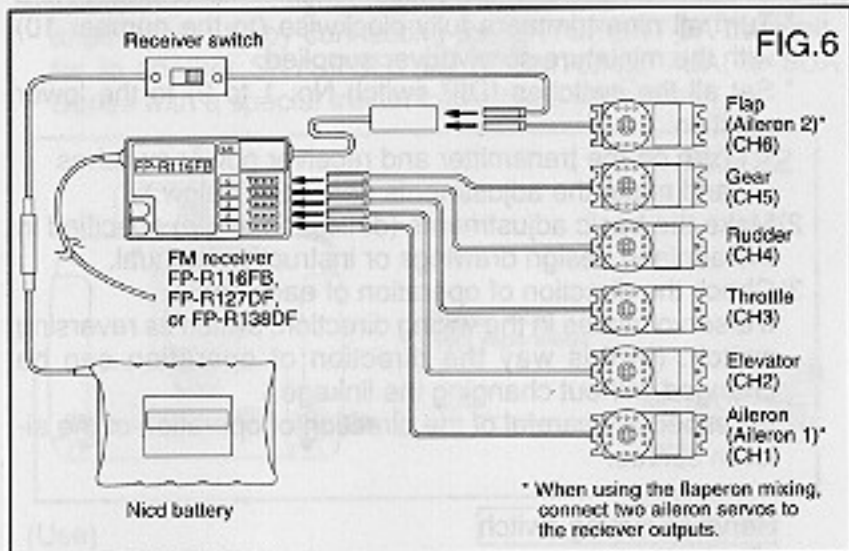

### (Installation precautions)

When installing the receiver, servos, and other parts to the fuselage, observe the following precautions:

#### Servo travel

Operate each servo horn over its full travel and check that the pushrod does not bind and or is not too loose. Unreasonable force applied to the servo horn will adversely affect the servo and drain the battery pack very quickly. Make sure that the free travel range of each control surface or mechanism somewhat larger than the full control travel (including trim) of the servo horn. Adjust the servo horns so that they move smoothly even when the trim lever and stick are operated simultaneously in the same direction.

#### Servo installation

Install the servos with the rubber grommets and eyelets supplied with the set. (FIG.8) Do not tighten the screws too tight. If the servo case directly contacts the fuselage, the rubber bushing will not serve its purpose.

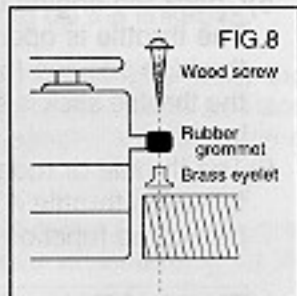

#### Receiver power switch installation

When installing the switch harness to the fuselage, cut a rectangular hole slightly larger than the full travel of the switch in the fuselage and install the switch so that it moves smoothly from ON to OFF. Also install the switch where it will not be exposed to engine oil or dust and dirt. Generally, install the receiver switch on the opposite side of the muffler exhaust.

#### Receiver antenna

Although the receiver antenna may appear to be too long, do not cut it or fold it back. Changing the length of the receiver antenna will lower the receiving sensitivity and shorten the flight range. Generally, the antenna can be strung out towards and attached to the vertical stabilizer. (FIG.9)



#### Receiver vibration and water proofing

The receiver contains precision electronic parts. Besides being susceptible to vibration and shock, the entry of water will also cause erroneous and dangerous results and has been associated with crashes and other accidents. Wrap the receiver in foam rubber or take other vibration countermeasures. Also waterproof the receiver by placing it in a plastic

bag and securing the open end of the bag with a rubber band. Do the same with the receiver and servo battery.

#### Servo horns

Spare horns are supplied. Use them as needed.

#### Extension cord

Use the servo extension cord if needed for your particular fuselage.

#### Digital Proportional Frequencies For U.S.A.

- The frequency of Futaba digital proportional sets can be changed within their own band. There are 2 different bands for you to choose from (27 MHz and 72-75 MHz). Please see chart listed below for specific frequency and its intended use. Please note there are specific frequencies allocated for aircraft only and surface only use.
- The frequency can be changed within the same BAND. However, Futaba recommends that you return your system to our factory service department for frequency changing, as tuning may be necessary for proper operation. Changing frequency from one band to another is NOT possible. Always change frequency flag when frequency is changed. The frequency flag is to be attached to the top of antenna and the channel designation to the base. (See Drawing)
- It is illegal to change crystals on 72-75 MHz bands in the U.S.A. unless performed by a licensed technician.

#### Antenna Frequency Flag

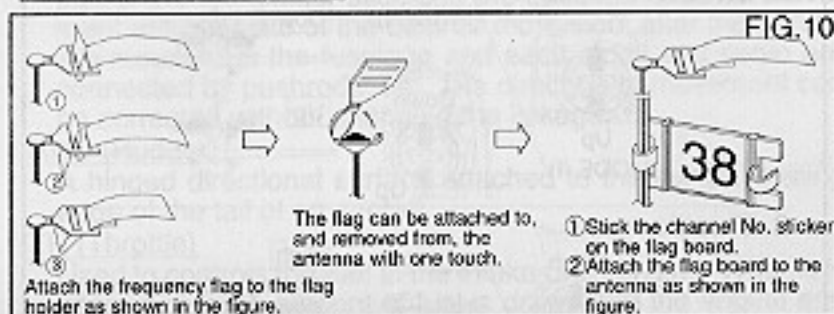

#### Frequency, Channel No. Flag Color For U.S.A.

##### 26-27 MHz-Aircraft/car/boat

Frequency	Color
26.995	Brown
27.045	Red
27.095	Orange
27.145	Yellow
27.195	Green
27.255	Blue

##### 50/53 MHz-Aircraft/car/boat-Fcc Amature Licence required (2 and 3 channels not produced on these frequencies).

Channel No.	Color
50.800 RC00	Black-Brown
50.820 RC01	Black-Red
50.840 RC02	Black-Orange
50.860 RC03	Black-Yellow
50.880 RC04	Black-Green
50.900 RC05	Black-Blue
50.920 RC06	Black-Violet
50.940 RC07	Black-Gray
50.960 RC08	
50.980 RC09	

##### 72MHz-Aircraft only

72.010 11	72.210 21	72.410 31	72.610 41	72.810 51
72.030 12	72.230 22	72.430 32	72.630 42	72.830 52
72.050 13	72.250 23	72.450 33	72.650 43	72.850 53
72.070 14	72.270 24	72.470 34	72.670 44	72.870 54
72.090 15	72.290 25	72.490 35	72.690 45	72.890 55
72.110 16	72.310 26	72.510 36	72.710 46	72.910 56
72.130 17	72.330 27	72.530 37	72.730 47	72.930 57
72.150 18	72.350 28	72.550 38	72.750 48	72.950 58
72.170 19	72.370 29	72.570 39	72.770 49	72.970 59
72.190 20	72.390 30	72.590 40	72.790 50	72.990 60

##### 75 MHz-Car/boat only

75.410 61	75.610 71	75.810 81
75.430 62	75.630 72	75.830 82
75.450 63	75.650 73	75.850 83
75.470 64	75.670 74	75.870 84
75.490 65	75.690 75	75.890 85
75.510 66	75.710 76	75.910 86
75.530 67	75.730 77	75.930 87
75.550 68	75.750 78	75.950 88
75.570 69	75.770 79	75.970 89
75.590 70	75.790 80	75.990 90

# ADJUSTMENTS

## 1. General fuselage adjustments

Make the basic fuselage linkage connections and adjustments specified in the fuselage manufacturer's assembly manual. In particular, check that the center of gravity is within the specified range.

Also make the receiver, servo, and battery connections in accordance with "CONNECTION OF RECEIVER, SERVOS, ETC." instructions on page 4.

Be sure to read and follow all of the "(Installation precautions)".

Before starting adjustment, carefully read the "Transmitter Operation and Control Surface Movement" section below.

(Transmitter Operation and Control Surface Movement)

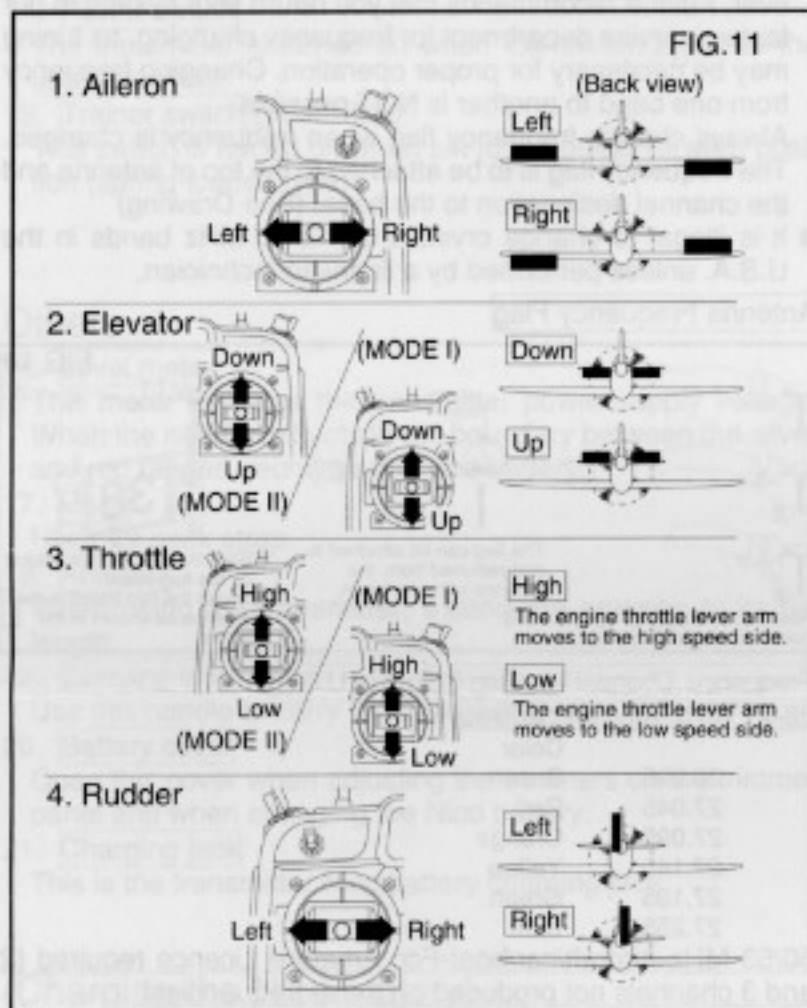

The following descriptions assume that the transmitter is held in the hands in the normal position.

- When the aileron stick is moved to the right, the right wing aileron is raised, the left wing aileron is lowered, and the plane will bank to the right. When the stick is moved to the left, the reverse maneuvers are performed.
- When the elevator stick is pulled back, the elevator is raised and the airplane climbs (Up operation). When the elevator stick is pushed forward, the elevator is lowered and the airplane dives (Down operation).
- When the throttle stick is pulled back, the engine throttle lever arm moves to the slow (low speed) side. When the throttle stick is pushed forward, the engine throttle lever arm moves to the high (high speed) side.
- When the rudder stick is pushed to the right, the rudder is deflected to the right and the nose of the airplane turns to the right. When the rudder stick is pushed to the left, the rudder is deflected to the left and the nose of the airplane turns to the left.

(Adjustment procedure)

### 1) Initial trimmer and switch setting

Before making any adjustments, open the battery cover at the back of the transmitter and set the trimmers and DIP switches on the trimmer panel to the initial state shown below.

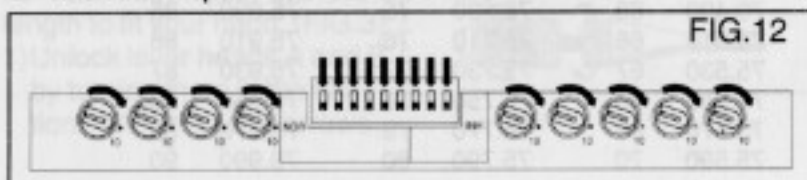

- Turn all nine trimmers fully clockwise (to the number 10) with the miniature screwdriver supplied.
- Set all the switches (DIP switch No. 1 to 9) to the lower position.

(Turn on the transmitter and receiver power switches and make the adjustments described below.)

2) Make the basic adjustments (deflection angle) specified in the airplane design drawings or instruction manual.

3) Check the direction of operation of each servo.

If a servo moves in the wrong direction, switch its reversing switch. (In this way the direction of operation can be changed without changing the linkage.)

Be especially careful of the direction of operation of the aileron servos.

### Servo reversing switch

(Setting)

The servo reversing switches (SERVO REVERSER) (DIP switch Nos. 1 to 6) on the trimmer panel can be set for each channel.

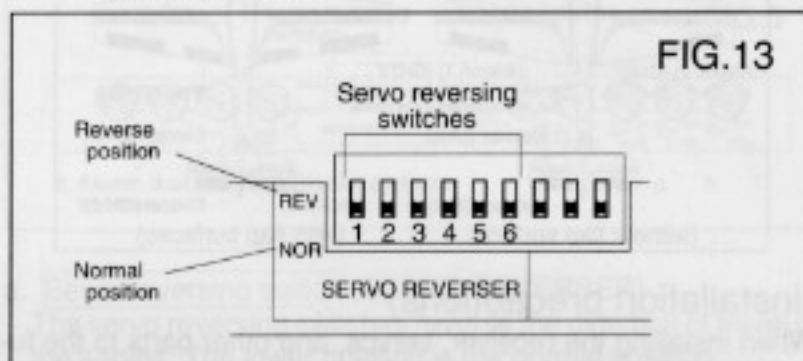

The lower (NOR) position is the normal position and the upper (REV) position is the reverse position.

4) Check the neutral adjustment and left and right (up and down) travel of each servo.

If the neutral position has changed, or the travel is incorrect, readjust it by changing the servo horn position on the splined shaft or by changing the hole position on the servo horn. (Adjust the neutral position by servo horn position when the transmitter trimmer is at the center.)

5) Check the engine throttle linkage.

The throttle is opened fully when the throttle stick is set to the high position (pushed forward) and is closed fully when the throttle stick is set to the maximum slow position (pulled back).

6) The throttle or rudder servo travel can be trimmed with the following throttle ATV or throttle AST/rudder AST function. Select the function you want to use.

### Throttle ATV function

(Function)

The high and low throttle servo travel can be adjusted independently. Use this function to compensate for throttle linkage variations. The travel rate can be adjusted from 30% to 100% of the total servo travel (each side) as shown in the figure.

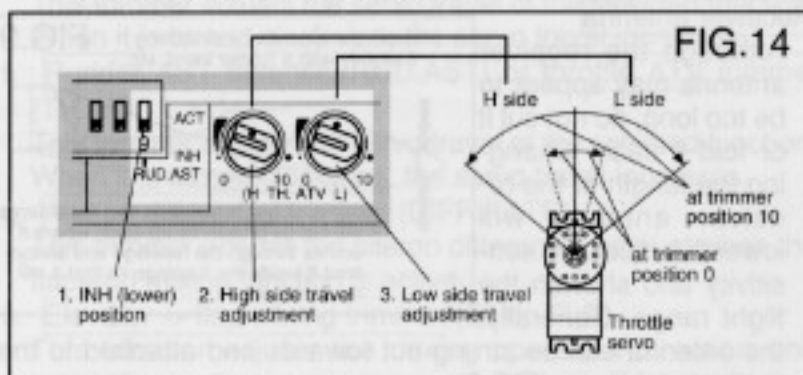

(Setting)

To activate the throttle ATV function, set the rudder AST (RUD.AST) ACT/INH switch (DIP switch No. 9) on the trimmer panel to the INH (lower) position. (Be aware that the rudder AST function and throttle ATV function cannot be used simultaneously.)

\* High side travel adjustment:

Adjust the high side travel with the high side trimmer (H)

of the TH.ATV trimmers on the trimmer panel. Adjust the high side travel to between high side trimmer positions 0 (30%) and 10 (100%).

**Low side travel adjustment:**

Adjust the low side travel with the low side trimmer (L) of the TH.ATV trimmers on the trimmer panel. Adjust the low side travel between low side trimmer positions 0 (30%) and 10 (100%).

**Throttle AST function**

**(Function)**

This function sets the throttle servo travel. In this case, the high side and low side can be adjusted simultaneously. Use this function to compensate for throttle linkage variation. The travel rate can be adjusted from 30% to 100% of the total servo travel as shown in the figure.

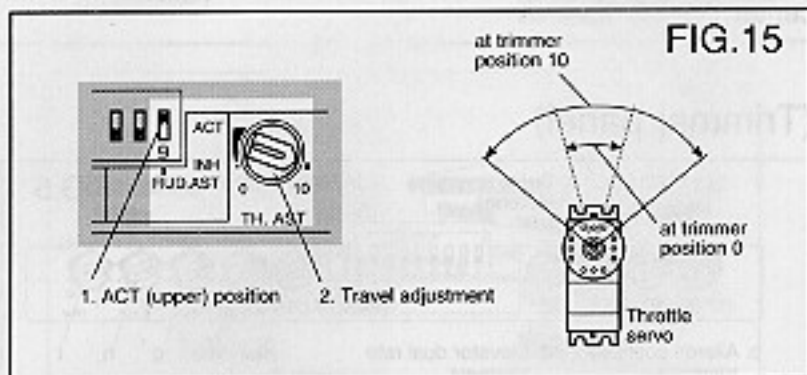

**(Adjustment)**

To activate the throttle AST function, set the rudder AST (RUD.AST) ACT/INH switch (DIP switch No. 9) on the trimmer panel to the ACT (upper) position. (The rudder AST function can be used simultaneously, but the throttle ATV function cannot be used simultaneously.)

**Travel adjustment:**

Adjust the servo travel with the TH.AST trimmer on the trimmer panel. Adjust the travel rate between throttle AST trimmer positions 0 (30%) and 10 (100%).

**Rudder AST function**

**(Function)**

This function adjusts the rudder servo travel. In this case, the left and right travels can be adjusted simultaneously. Use this function in rudder linkage correction. The travel rate can be adjusted from 30% to 100% of the total servo deflection angle as shown in the figure.

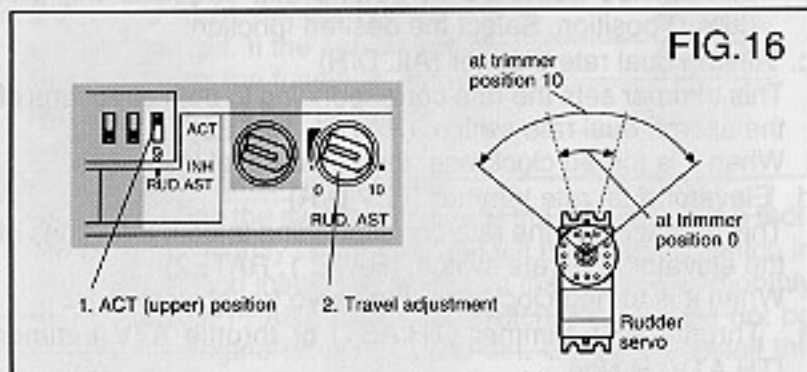

**(Adjustment)**

To activate the rudder AST function, set the rudder AST (RUD.AST) ACT/INH switch on the trimmer panel to the ACT position. The throttle AST function can be used simultaneously, but the throttle ATV function cannot be used simultaneously.)

**Travel adjustment:**

Adjust the servo travel with the RUD.AST trimmer on the trimmer panel. Adjust the travel to between rudder AST trimmer positions 0 (30%) and 10 (100%).

**Throttle trim lever with ATL function**

**(Function)**

As shown in the figure, when the throttle stick is set to the maximum slow side, the throttle trim influence is also at it's maximum. When the throttle stick is in the high side the throttle trim has no influence. This greatly simplifies throttle linkage adjustment. (The high side linkage should be set first.)

FIG. 17

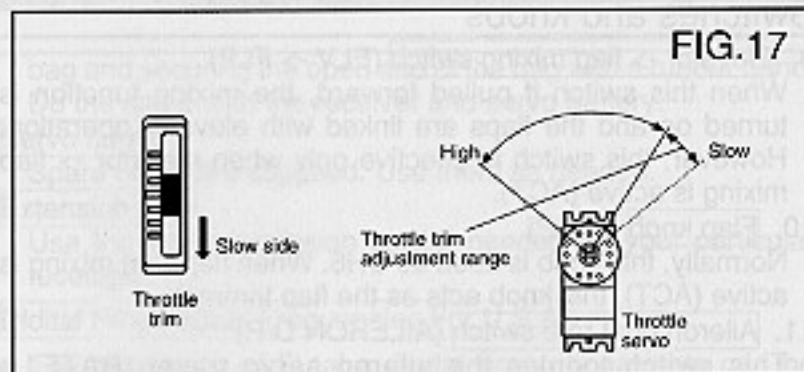

7) After connecting the linkages and checking the operating directions and amounts, start the engine and adjust the engine needle, then fly the airplane and trim the servos.

**2. Aileron/elevator dual rate (D/R) function**

**(Function)**

The maximum travel of the aileron and elevator servos can be altered by operating their respective dual rate switch. For instance, when the switch is in the down (RATE2) position, the deflection angle is the normal deflection angle. When the switch is set to the upper (RATE1) position, spins, snap rolls, and other aerobatics that require a maximum deflection angle can be performed by adjusting the deflection angle to an angle greater than the normal deflection angle. Since the respective rates can be adjusted by setting the switch to the upper and down positions, the direction of the switch can be set as desired.

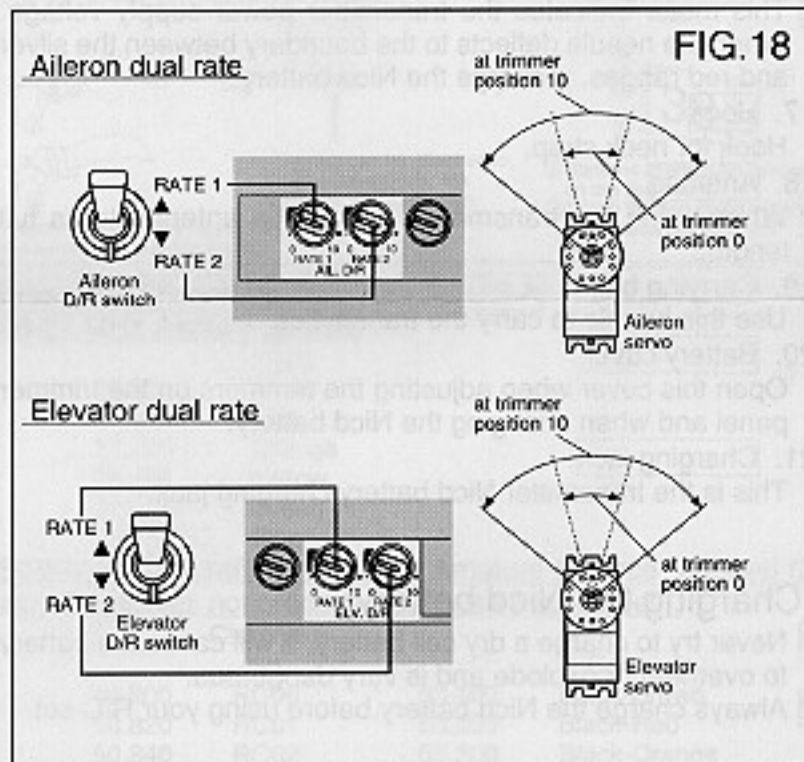

**(Switch operation)**

The aileron dual rate switch (AILERON D/R) is at the front top right side of the transmitter. The upper position is RATE1 and the down position is RATE2.

The elevator dual rate switch (ELEVATOR D/R) is at the front top left side of the transmitter. The upper position is RATE1 and the down position is RATE2.

**(Rate adjustment)**

Each rate can be adjusted with the RATE1 and RATE2 trimmers on the trimmer panel behind the battery cover at the back of the transmitter. The rate can be adjusted from 30% (position 0) to 100% (position 10) of the maximum deflection angle.

**(Setting procedure)**

- 1) Turn on the transmitter and receiver power.
- 2) Switch the dual rate switch of the channel you want to the position for the rate that you want to set.
- 3) Set the stick to the maximum travel in either direction.
- 4) Using the trimmer, adjust the servo horn to the desired angle. (Adjust each rate by repeating steps 1 through 4.)

\* When not using the dual rate function, set the RATE1 and RATE2 trimmers to 100% (fully clockwise).

**3. Flaperon mixing**

(with aileron differential function)

(Function)

This function lets you mix the flap and aileron functions by using the same control surfaces (ailerons) and servos for both controls. Two aileron servos are mounted in the wing. Aileron operation is accomplished normally, i.e. left and right ailerons moved up and down in opposite directions. Flap operation is accomplished by moving the left and right ailerons in the same direction. (Flap operation can be performed without the need for separate flap surfaces.)

- \* With this function the left and right ailerons can be operated differentially. (Aileron differential function). Roll axis can be compensated in this way. With aileron differential the aileron down deflection angle is typically smaller than the up angle.
- \* The flap control knob rate can be adjusted.

(Adjustment)

Connect the aileron servos to receiver output channels 1 and 6. Adjustment when CH1 is connected to the right wing and CH6 is connected to the left wing is described below. (The trimmer adjustment direction may be reversed, depending on the servo mounting direction and linkage method.)

1) Activate mixing:

To activate flaperon mixing, set the flaperon ACT/INH switch (DIP switch No. 8) on the trimmer panel behind the battery cover at the back of the transmitter to the ACT (upper) position. To deactivate flaperon mixing, set the switch to the INH (lower) position.

2) Aileron differential adjustment:

Adjust the aileron differential with the DIFF.RATE trimmer on the trimmer panel.

First set the DIFF.RATE trimmer fully clockwise (to number 10) so that differential is not applied. When the roll axis must be compensated after test flying, make the adjustments described below. However, the trimmer adjustment position depends on the direction in which the deflection angle decreases.

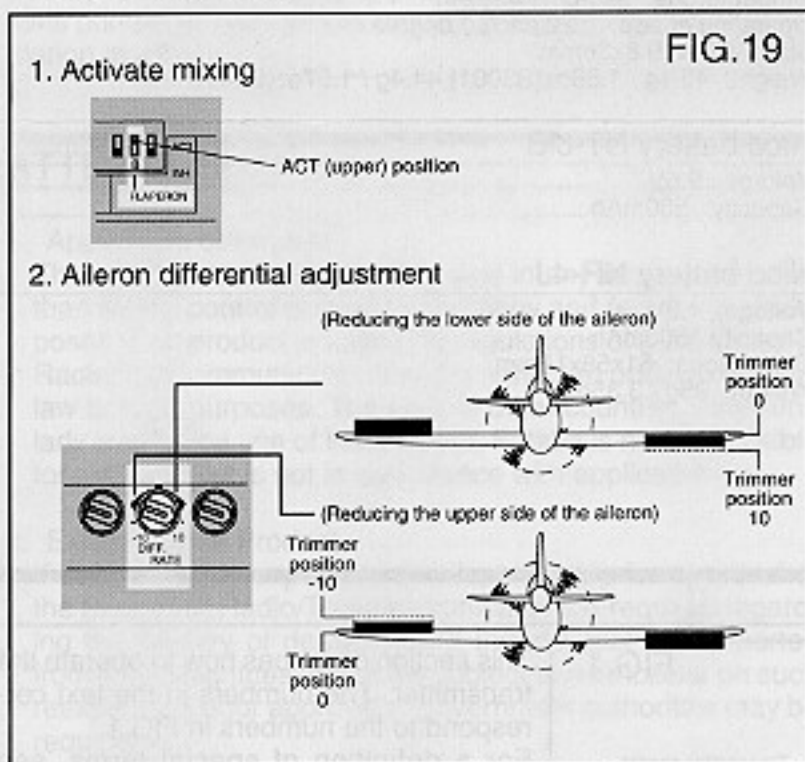
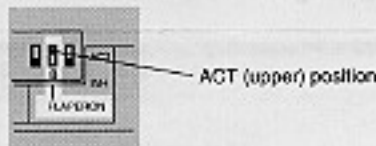
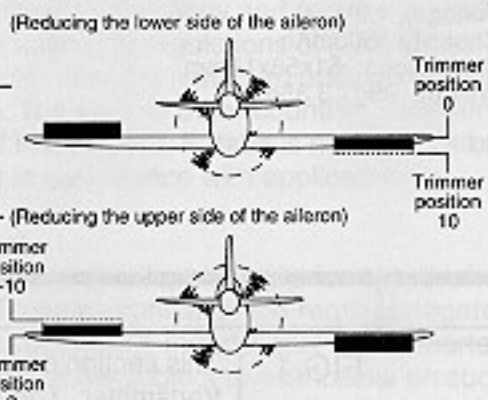

FIG. 19

1. Activate mixing



2. Aileron differential adjustment



- \* Applying differential by reducing the low side of the aileron: Adjust between DIFF.RATE trimmer positions 0 and 10 (right half of trimmer). At position 10, differential is not applied. At position 0 (trimmer center), the reducing amount is maximum.
- \* Applying differential by reducing the high side of the aileron: Adjust to between DIFF.RATE trimmer positions 0 to -10 (left half of trimmer). At position -10, differential is not applied. At position 0 (trimmer center), the reducing amount is maximum.

3) Flap control knob rate adjustment

Adjust the flap control knob rate with the FLP.TRIM trimmer on the trimmer panel. The flap control knob operating direction can be set at the same time.

- \* Lowering the flaps by turning the flap knob clockwise (CW): Adjust the flap control knob to between FLP.TRIM positions 0 and 10 (right half of trimmer).
- \* Lowering the flaps by turning the flap knob counterclockwise (CCW): Adjust to between FLP.TRIM trimmer positions 0 and -10

3. Flap control knob rate adjustment

FIG. 20

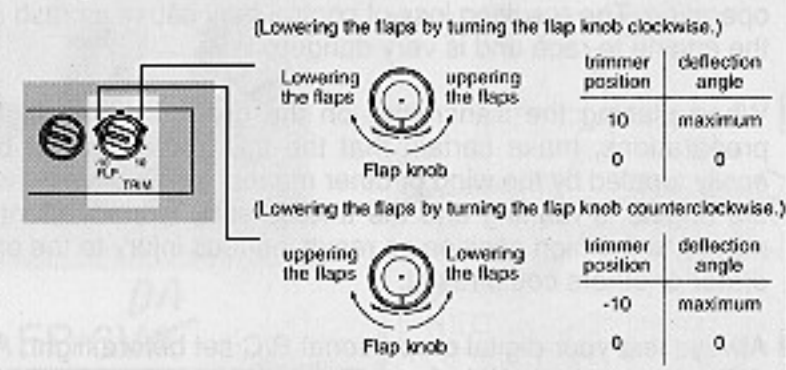

(left half of trimmer).

In both cases the deflection angle decreases as the knob is turned toward position 0 (trimmer center).

4. Elevator -> flap mixing

(Function)

This function is used when the aircraft has flaps or is using the flaperon mixing function. This can be used, for example, to deploy flaps when pulling up elevator. Cleaner loops and other aerobatic maneuvers can be performed using this function. Adjust the mixing amount to the optimal positions for your model.

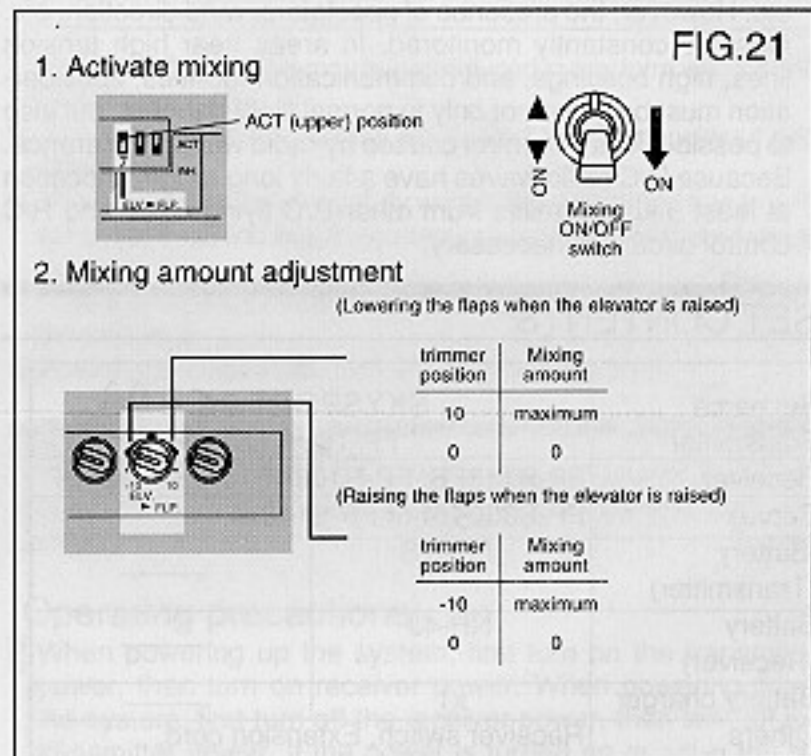
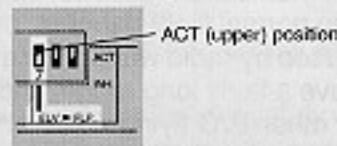

FIG. 21

1. Activate mixing



2. Mixing amount adjustment

(Lowering the flaps when the elevator is raised)

trimmer position	Mixing amount
10	maximum
0	0

(Raising the flaps when the elevator is raised)

trimmer position	Mixing amount
-10	maximum
0	0

(Operation)

The elevator -> flap mixing ON/OFF switch is at the right side of the transmitter. It is turned on when pulled forward.

(Adjustment)

1) Activate the mixing function:

To activate the elevator -> flap mixing function, set the elevator -> flap mixing ACT/INH switch (DIP switch No. 7) on the trimmer panel to the ACT (upper) position. To deactivate the mixing function, set the ACT/INH switch to the INH position.

2) Mixing amount adjustment:

Adjust the mixing amount with the ELV.->FLP trimmer on the trimmer panel. The adjustment range is -100 to +100% (positions -10 to +10). The mixing direction can be adjusted at the same time.

- \* Applying mixing which lowers the flaps when the elevator is raised:

Adjust between ELV.->FLP trimmer positions 0 and 10 (right half of trimmer). At position 10, the mixing amount is maximum and at position 0, the mixing amount becomes 0. Adjust the mixing amount to the optimal position for your aircraft.

- \* Applying mixing which raises the flaps when the elevator is lowered:

Adjust between ELV.->FLP trimmer position 0 and -10 (left half of trimmer). At position -10, the mixing amount is maximum and at position 0, the mixing amount becomes 0. Set the mixing amount to the optimal position for your aircraft.

## 5. Using the trainer function

You can practice flying with the aid of another pilot or help another pilot fly by connecting the SKYSPORT-6A transmitter to another SKYSPORT-6A, PCM1024Z, 7UA, or 5UA Series with a special trainer cable (sold separately).

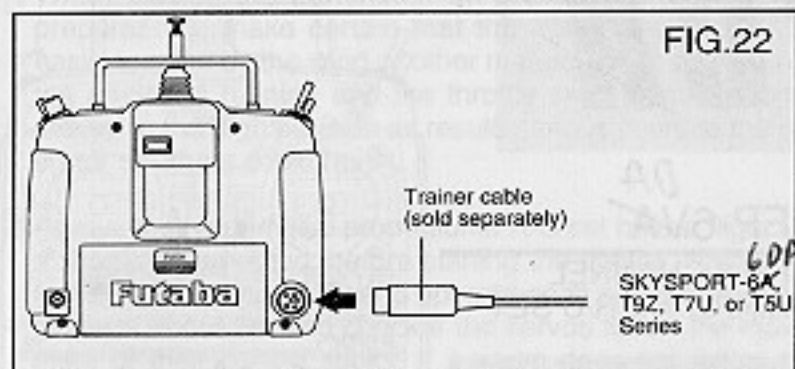

### (Use)

The model is controlled by the instructor transmitter when the trainer switch is OFF and is controlled by the student transmitter when trainer switch to ON.

### (Usage precautions)

- \* Never turn on the student transmitter power switch.
- \* Make the student transmitter and instructor transmitter settings the same.
- \* Make sure the modulation method of the other transmitter is FM (PPM).

## GLOSSARY OF TERMS

The abbreviations used with the SKYSPORT-6A are defined below in alphabetical order.

### ACT (activate)

Means that a function is turned on. Its opposite is INH (inhibit).

To activate a function, its ACT/INH switch is set to the ACT position. If the switch is not in the ACT position, the function is not activated.

### AILERON / AIL.

An auxiliary airfoil at the left and right wings of an airplane to control its rolling.

### AST (Adjustable Servo travel)

This feature allows adjustment of the travel of the servo of a certain channel. It is used when setting up the linkages.

### ATL (Adjustable Throttle Limit)

This feature allows movement of the throttle trim lever that operates only when the throttle stick is in the SLOW position. It is convenient because it does not affect the HIGH side of the throttle.

### ATV (Adjustable Travel Volume)

This feature allows independent adjustment of the servo travel in each direction. It is convenient when setting up the linkages.

### D/R (Dual Rate)

This function allows switching to one of two deflection angles while flying. The deflection angle best for the aircraft can be set for one switch position and spins, snap rolls, and other aerobatics that require a maximum deflection angle can be performed easily by setting up maximum deflection for the other switch position.

### DIFF. (aileron differential)

This feature allows application of a differential to the right wing aileron and left wing aileron when the wing has two aileron servos. It is used to correct undesirable tendencies and to compensate the roll axis.

### ELV.->FLP. (elevator->flap mixing)

This feature applies mixing from the elevators to the flaps when the fuselage has flaps. When mixing is applied so that the flaps are lowered when the elevators are raised, loops and other aerobatics can be performed cleanly. The mixing amount should be adjusted optimally for individual aircraft.

### ELEVATOR / ELV.

A horizontal airfoil for making an airplane go up or down.

### FLAPERON

This is a mixing function that gives the ailerons a flap function.

It is a convenient method of mixing aileron operation and flap operation using only two aileron servos at the wings. (Flap operation can be performed without the need for separate flap surfaces.)

### FLP. (Flap)

A movable auxiliary airfoil attached to the center of a wing to increase the lift at slow speed when taking off and landing. With models it can also be mixed with the elevator and used in circular aerobatics.

### FLP.TRIM (Flap trim)

This feature switches the flap servo deflection angle between normal operating angle and trim angle. It is convenient when mixing the flaps with other channels.

### GEAR (Landing gear)

This is for airplane landing gear.

Since the landing gear is normally extended or retracted, this channel can only be turned fully on or off. It cannot be stopped midway.

### INH (Inhibit)

Means that the function is turned off (stopped). It is the opposite of ACT (activate). When a function is not used, its ACT/INH switch is always set to the INH position.

### NOR (Normal)

Used to represent the default or normal state of a function. For example, the servo reversing function has a normal side and a reverse side.

### RATE

In the dual rate function for example, this is the rate of servo travel in percentage relative to the normal servo travel. The rate is adjusted with a trimmer for each function.

### REV (Reverse)

Represents the servo reversing function that lets you reverse the normal direction of servo movement, or the setting position of a switch (reverse position). It is used when the direction of the transmitter stick and the direction of servo movement are opposite of the desired movement after the servos are mounted in the fuselage and each airfoil and servo are connected by pushrods, etc. The direction of movement can be corrected without changing the linkage.

### RUD (Rudder)

A hinged directional surface attached to the vertical trailing edge of the tail of an aircraft.

### TH (Throttle)

Used to controls the fuel at the intake of an engine. When it is opened, a large amount of fuel is drawn into the engine and the engine speed increases. When it is closed, the engine speed slows.

### TRIM

A fine adjustment device that sets the deflection angle of each airfoil for stable flight.

### (OTHERS)

#### Mixing

A function that allows two or more different channels to be operated together in a linked or dependent manner.

For example, when mixing is applied from elevators to flaps, the elevator servo and flap servo can be operated simultaneously by operation of the elevator stick.

## REPAIR SERVICE

Before requesting repair, please refer to this instruction manual again and verify your settings. If you are still experiencing trouble, please request service as follows:

### Address

Your nearest Futaba dealer.

### Repair information

Describe the trouble in as much detail as possible.

- 1) Symptom: Including the state of the set when the trouble occurred.
- 2) Digital proportional set used: Transmitter, receiver, and servo model numbers.
- 3) Fuselage: Fuselage name and mounting conditions.
- 4) Your name, address, and telephone number.

### Warranty contents

Read the warranty card supplied with your set.

- \* The warranty contents differ with geographic locations.



### FUTABA CORPORATION

Mikubari Techno Garden Bldg., B6F 1-3 Nakase, Mihama-ku, Chiba 261-01, Japan  
Phone: (043) 296-5119 Facsimile: (043) 296-5124

### FUTABA CORPORATION OF AMERICA

4 Studebaker, Irvine California 92718, U.S.A.  
Phone: 714-455-9888 Telex: 23-0691227 Facsimile: 714-455-9899