

2 (Channel setup)

The channel list screen used for the front ESC channel is displayed. Tap the auxiliary channel that connected the front ESC channel.

- When all channels are in use, a screen saying "No assignable channel" is displayed, please turn off other mixing and make an unused channel. You can check the mixing used on the channel setting screen (page 75).

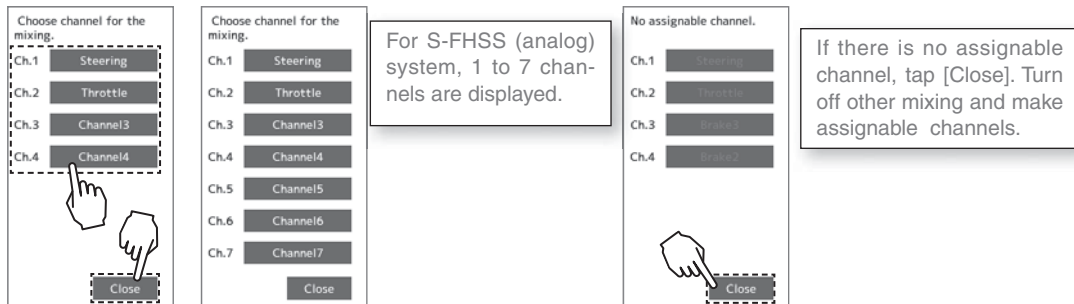

3 (Drive ratio adjustment)

Adjust the front and rear motor controller operation amount by Δ or ∇ button. The ∇ button increases and the Δ button decreases the rear ratio.

Both the front and rear ratios become 100%

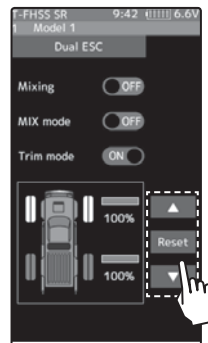

Adjustment buttons

- Adjust with the Δ and ∇ buttons.
- Return to the initial value by tapping the [reset] buttons.

Rear rate (Rear mix rate)

0~100
Initial value:100

4 (Mix mode setting)

Tap "MIX mode" (ON) or (OFF) to select ON / OFF.

"OFF" :The EXP function of the 2nd CH and other settings are not mixed.

"ON" :The EXP function of the 2nd CH and other settings are mixed.

Setting

- Tap (ON) / (OFF).

5 (Trim mode setup)

Tap "Trim mode" (ON) or (OFF) to select ON / OFF.

"OFF" :The trim of the 2nd CH is not mixed.

"ON" :The trim of the 2nd CH is mixed.

Setting

- Tap (ON) / (OFF).

6 When finished, return to the Mixing menu screen by pressing the HOME button twice.

Dial / Trim Setting

The dial select function can control the drive ratio with digital dial or digital trim.(page 66)

Note:

As this function drives 2 separate motor controllers simultaneously, a mutual load is applied. Use this function carefully so that the motor controllers are not damaged. Futaba will not be responsible for motor controller, motor, and other vehicle trouble due to use of this function.

CPS Mixing (1, 2, 3)

This function controls the Futaba CPS-1 channel power switch. Normally, when using the CPS-1 unit to light the vehicle dress-up and other illumination (LED) the CPS-1 unit with LED connected is connected to a vacant switch channel and the LEDs are turned on and off by switch while the vehicle is running. However, when the CPS mixing function is used, the LED can be turned on and off and flashed in step with steering and throttle operation, as well as being turned on and off by switch. The flashing speed (cycle) can also be set. For instance, the LED can be flashed as a brake light by throttle brake side operation. Three lines of CPS mixing can be used.

The CPS-1 unit does not operate in SR mode. When using with the T - FHSS SR system, connect it to the channel of the normal mode.

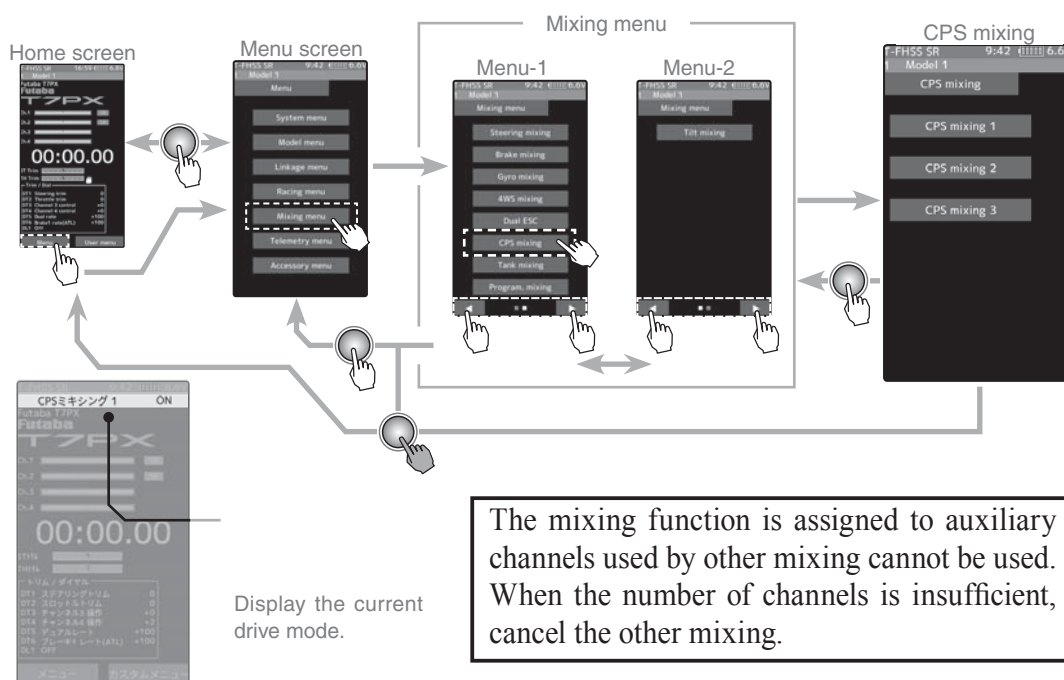

The mixing function is assigned to auxiliary channels used by other mixing cannot be used. When the number of channels is insufficient, cancel the other mixing.

Dual ESC mixing adjustment

(Preparation)

- CPS-1 connects to the receivers auxiliary channel.
- When the LEDs are turned on and off by switch, use the function select switch function (page 69) to set the switch to be used.
- From the CPS Mixing screen, tap [CPS Mixing 1] / [CPS Mixing 2] or [CPS Mixing 3] to display the setting screen.

Setting

- Tap (ON) / (OFF).

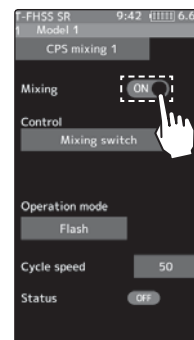

1 (Function ON/OFF)

Tap "Mixing" (ON) or (OFF) to select ON / OFF.

"OFF" :Mixing function OFF

"ON" :Mixing function ON

2 (Channel setup)

The channel list screen used for the front ESC channel is displayed. Tap the auxiliary channel that connected the front ESC channel.

- When all channels are in use, a screen saying "No assignable channel" is displayed, please turn off other mixing and make an unused channel. You can check the mixing used on the channel setting screen (page 75).

3 (Control system setup)

Tap the [Control]. The mode list appears on the CP-1 mixing menu screen, and tap from the list and select the control mode. To cancel, tap [Cancel].

"Mixing Switch" : ON/OFF by switch set at the CPS mixing
"Steering neutral" : ON at steering neutral
"Steering endpoint" : ON at both sides of steering
"Throttle neutral" : ON at throttle neutral
"Throttle forward" : ON at throttle forward side
"Throttle brake" : ON at throttle back (brake) side
"Throttle neutral & brake" : ON at throttle neutral and back (brake) sides

Setting

- Tap control mode.

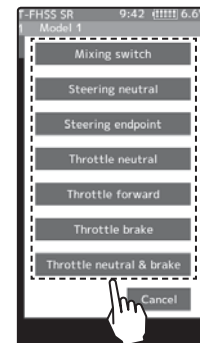

4 (ON / OFF switching position selection)

Tap the value button of the [ON/OFF point]. Value input buttons appear on the screen. Use the [+] and [-] buttons to adjust the operation point. Since the ON/OFF state is displayed at the right side of the "Status", setting can be confirmed while operating the function to be controlled (for example, throttle).

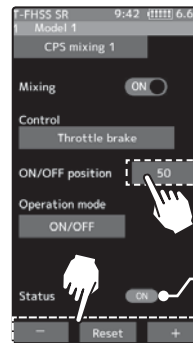

Adjustment buttons

- Adjust with the Δ and ▽ buttons.

- Return to the initial value by tapping the [reset] buttons.

ON/OFF position

5 ~ 95
Initial value:50

*Shows the ON/OFF state

5 (Operation mode setup)

Tap the [Operation mode]. The mode list appears on the CP-1 mixing menu screen, and tap from the list and select the Operation mode. To cancel, tap [Cancel].

"ON/OFF" : Normal ON/OFF type
"Flash" : Flashing display

Setting

- Tap operation mode.

6 (Flashing cycle setting)

When "Operation mode" is set to "Flash" the "Cycle speed" can be set to preferred setting. Tap the value button of the [Cycle speed]. Value input buttons appear on the screen. Use the [+] and [-] buttons to adjust the cycle speed amount.

Adjustment buttons

- Adjust with the [+] and [-] buttons.

- Return to the initial value by tapping the [reset] buttons.

Cycle speed amount

1~100
Initial value: 50

7 When finished, return to the Mixing menu screen by pressing the HOME button twice.

Tank Mixing

This function is intended for vehicles such as tanks and can be used to the pivotal turn, or the ultra-pivotal brake turn, by steering and throttle operation.

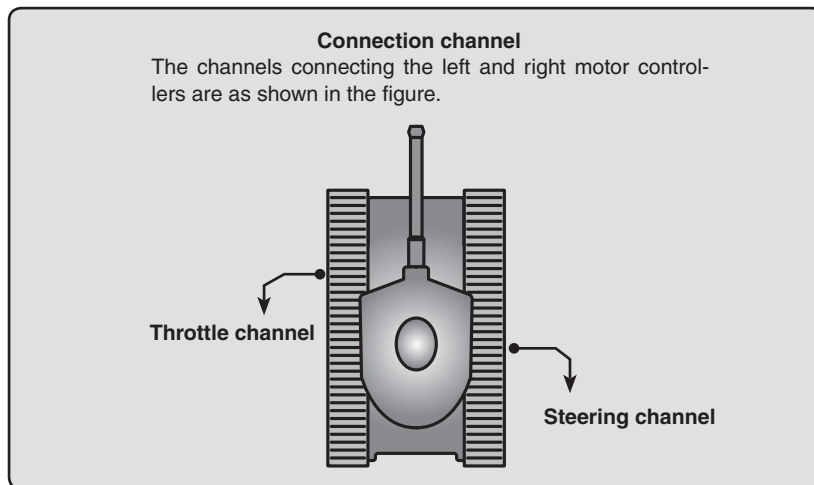
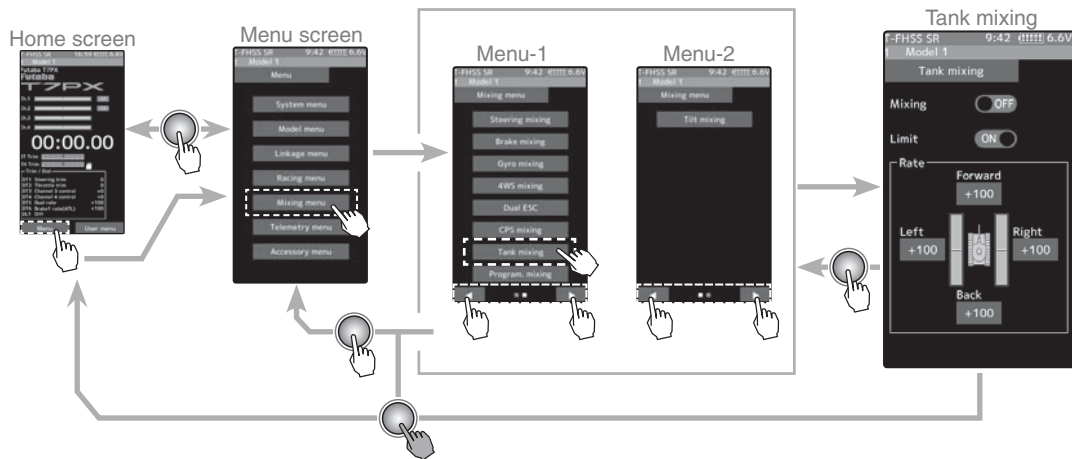

Tank mixing adjustment

Function

- 1 (Function ON/OFF)
Tap "Mixing" (ON) or (OFF) to select ON / OFF.
"OFF" :Mixing function OFF
"ON" :Mixing function ON

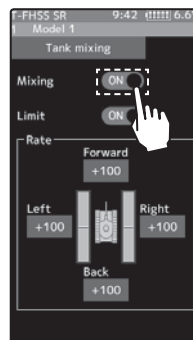

Setting
- Tap (ON) / (OFF).

2 (Limit ON / OFF)

It is a function to limit the maximum operation amount of the steering and throttle channel so that it does not exceed the limit by the influence of the mixing amount.

Tap "Limit" (ON) or (OFF) to select ON / OFF.

"OFF" :Limit function OFF
"ON" :Limit function ON

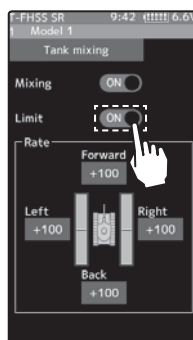

Setting

- Tap (ON) / (OFF).

3 (Forward / backward rate adjustment)

Tap the value button of the [Forward] or [Bck]. Value input buttons appear on the screen. Use the [+] and [-] buttons to adjust the forward or reverse speed.

- The throttle channel and the steering channel operate in conjunction with each other, and by operating the trigger to the high side, the car body advances at the [Forward] rate. When the trigger is operated to the brake side, it operates at the [Bck] rate.

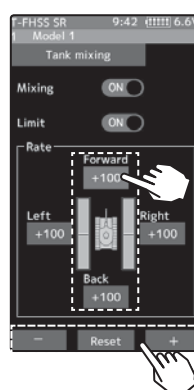

Adjustment buttons

- Adjust with the [+] and [-] buttons.
- Return to the initial value by tapping the [reset] buttons.

Forward / backward rate

-100~+100
Initial value: +100

4 (Left / Right side travel adjust)

Tap the value button of the [Left] or [Right]. Value input buttons appear on the screen. Use the [+] and [-] buttons to adjust the left or right side travel amount.

- When the throttle channel and the steering channel work in conjunction, when operating the steering wheel to the right, the car body turns to the right at the [Right] rate the pivotal turn. If you operate to the left, the car will turn to the left at the [Left] rate the pivotal turn.

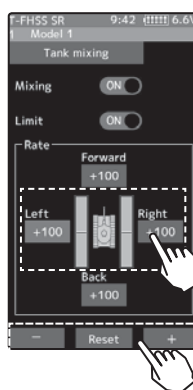

Adjustment buttons

- Adjust with the [+] and [-] buttons.
- Return to the initial value by tapping the [reset] buttons.

Left / Right travel

-100~+100
Initial value: +100

5 When finished, return to the Mixing menu screen by pressing the HOME button twice.

When steering and trigger are operated at the same time.

If you manipulate the trigger to the high side and operate the steering wheel to the right, the body will turn right at the rate of [forward], [right].

If you manipulate the trigger to the high side and operate the steering wheel to the left, the body turns to the left at the rate of [forward], [left].

Operating the steering wheel while operating the trigger to the brake side will operate the same as the forward side in the reverse direction.

Program, Mixing (1, 2, 3, 4, 5)

These functions allow you to apply mixing between the steering, throttle and auxiliary channel.

Additional Functions

- When the steering or throttle channel is the master channel (channel that applies mixing), trim data can be added. (Trim mode)
- The mixing mode selection. (Master mixing mode)
- The master channel mixing center point (point at which the direction changes) can be offset. (Offset function)

Movement of the slave channel side

The movement of the master channel side will be added to the movement of the slave channel side.

When trigger ratio was set to 100:0

When trigger ratio (page 62) is set to 100:0, brake operation stops. When the master channel is set to throttle, mixing operates only at the "Rate A (forward)" side. It does not operate at the "Rate B (brake)" side.

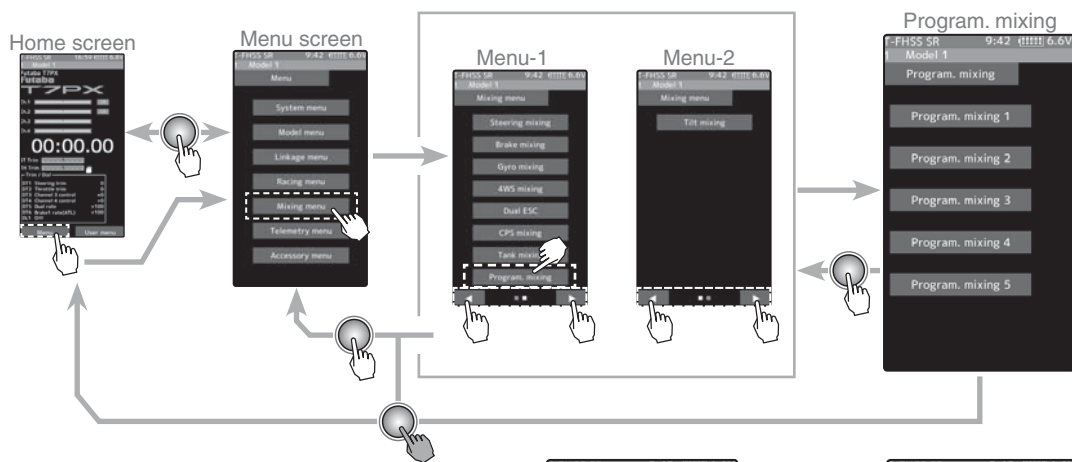

Function

The mixing function is assigned to auxiliary channels used by other mixing cannot be used. When the number of channels is insufficient, cancel the other mixing.

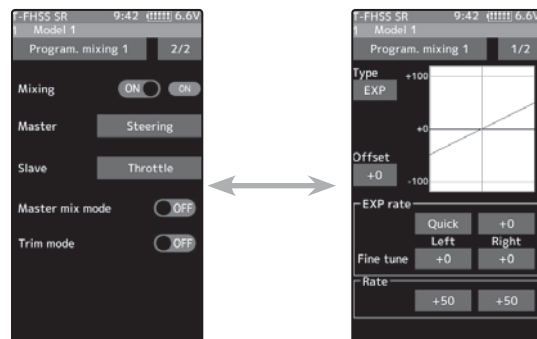

On the page 1, the setting screen such as the curve, mixing rate adjustment screen, page 2, mixing ON / OFF etc. is displayed.

Program composite adjustment

(Preparation)

- Use the switch select function (page 69) to select the switch. (as desired)
- From the Program Mixing screen Tap [Program Mixing 1] - [Program Mixing 5] to use to move to the setting screen.

1 (Function ON/OFF)

Tap [1/2] at the upper right of the screen to display page 2.

Tap "Mixing" (ON) or (OFF) to select ON / OFF.

"OFF" :Mixing function OFF

"ON" :Mixing function ON

Setting

- Tap (ON) / (OFF).

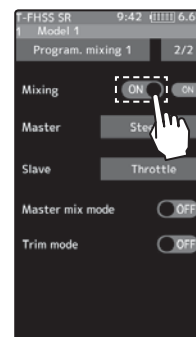

2 (Master / Slave channel setup)

Tap the [Master] or [Slave], and the channel setting screen will be displayed. Tap on that channel to select.

To cancel, tap [Close].

Setting

- Tap channel.

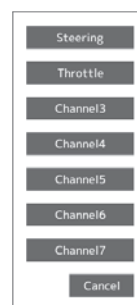
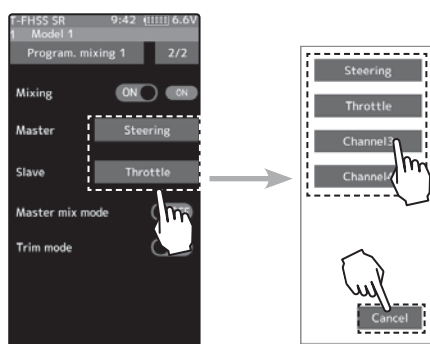

For S-FHSS (analog) system, 1 to 7 channels are displayed.

3 (Mix mode setting)

Tap "MIX mode" (ON) or (OFF) to select ON / OFF.

"OFF" :The EXP function of the 2nd CH and other settings are not mixed.

"ON" :The EXP function of the 2nd CH and other settings are mixed.

Setting

- Tap (ON) / (OFF).

4 (Trim mode setup)

Tap "Trim mode" (ON) or (OFF) to select ON / OFF.

"OFF" :The trim of the 2nd CH is not mixed.

"ON" :The trim of the 2nd CH is mixed.



5 (Left, Forward or A side mixing amount adjustment)

Tap the value button of the "Rate" [Left], [Forward] or [Rate A]. Value input buttons appear on the screen, adjust each of the left, forward or A steering angles using the [+] or [-] button.

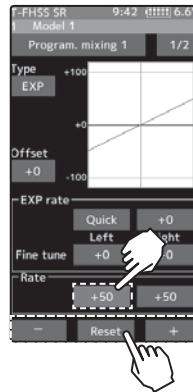

Adjustment buttons

- Adjust with the [+] and [-] buttons.
- Return to the initial value by tapping the [reset] buttons.

Left / Forward / A side rate

-120~0 ~+120
Initial value: +50

6 (Right, brake or B side mixing amount adjustment)

Tap the value button of the "Rate" [Right], [Brake] or [Rate B]. Value input buttons appear on the screen, adjust each of the right, brake, or rate B steering angles using the [+] or [-] button.

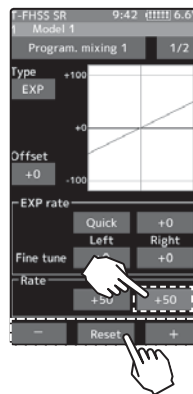

Adjustment buttons

- Adjust with the [+] and [-] buttons.
- Return to the initial value by tapping the [reset] buttons.

Right / Brake / B side rate

-120~0 ~+120
Initial value: +50

7 (Curve setting)

"EXP / VTR / Curve" mixing can be set from master channel to slave channel. For details on how to set each curve, please read the steering curve and the throttle curve (pages 78 to 83).

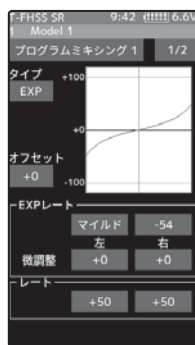

EXP curve

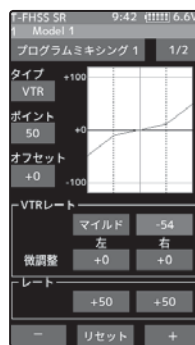

VTR curve

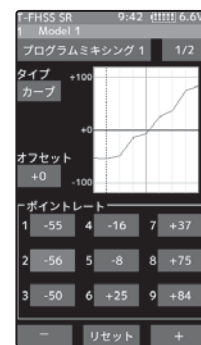

Curve

8 When finished, return to the Mixing menu screen by pressing the HOME button twice.

Tilt Mixing

Tilt mixing uses an outboard engine and applies bidirectional mixing from rudder to steady to flap and from flap to rudder so that with a boat, rudder operation and tilt mixing operation can be performed 2 servos.

Tilt mixing can be performed by rudder operation, by steering wheel and flap channel.

Effect of the set value of other functions on tilt mixing

Steering end point function, curve function, speed function, or D/R function setup also effects flap channel operation. However, even if set, steering reverse function setup does not reverse the flap channel.

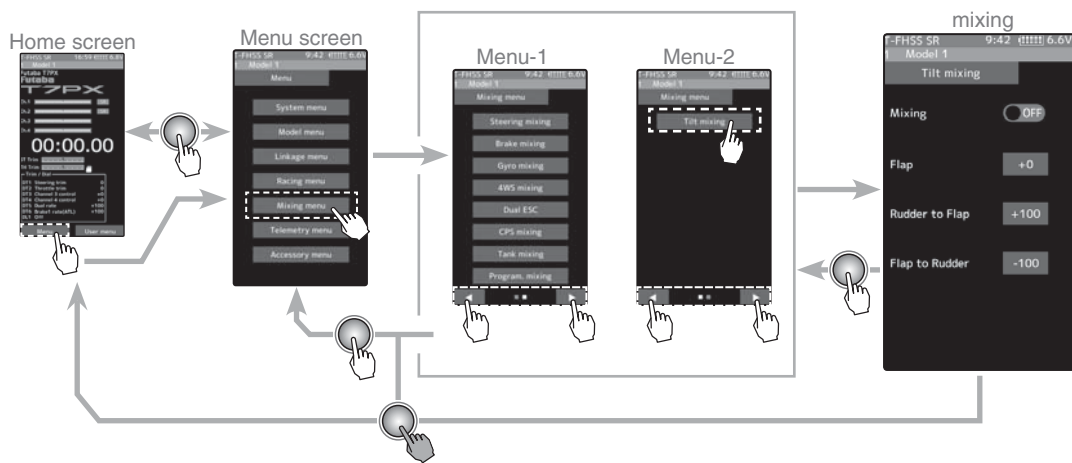

The mixing function is assigned to auxiliary channels used by other mixing cannot be used. When the number of channels is insufficient, cancel the other mixing.

Program composite adjustment

(Preparation)

- Use the "Trim/dial select" function to select the flap channel operation dial. (page 662)

1 (Function ON/OFF)

Tap [1/2] at the upper right of the screen to display page 2.

Tap "Mixing" (ON) or (OFF) to select ON / OFF.

- "OFF" :Mixing function OFF
- "ON" :Mixing function ON

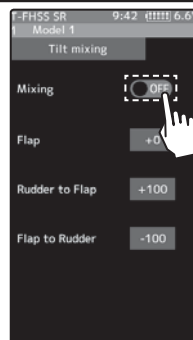

Setting

- Tap (ON) / (OFF).

2 (Channel setup)

The channel list screen used for the gain steering channel is displayed. Tap the auxiliary channel that connected the gain steering channel.

- When all channels are in use, a screen saying "No assignable channel" is displayed, please turn off other mixing and make an unused channel. You can check the mixing used on the channel setting screen (page 75).

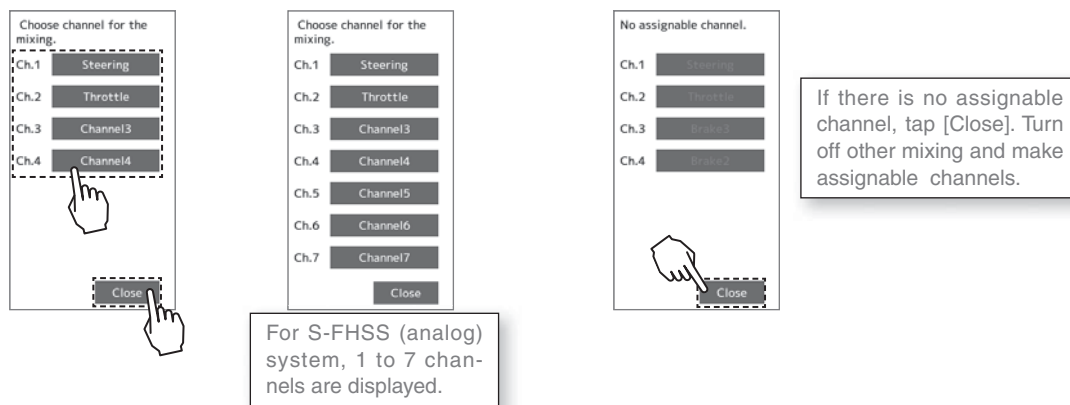

3 (Flap rate check and adjustment)

Select the "Flap" by (JOG) button up or down operation, and adjust the flaps by [+] or [-] operation.

4 (Rudder to Flap mixing amount adjustment)

Tap the value button of the "Rudder to Flap", Value input buttons appear on the screen, and use the [+] and [-] buttons to adjust the mixing amount.

- "+" :Operate in same direction as steering
- "-" :Operate in opposite direction of steering

5 (Flap to Rudder mixing amount adjustment)

Tap the value button of the "Flap to Rudder", Value input buttons appear on the screen, and use the [+] and [-] buttons to adjust the mixing amount.

- "+" :Operate in same direction as auxiliary channel
- "-" :Operate in opposite direction of auxiliary channel

Adjustment buttons

- Adjust with the [+] and [-] buttons.
- Return to the initial value by tapping the [reset] buttons.

Mixing amount (Rudder to Flap)

-100~+0~+100
Initial value: +100

Mixing amount (Flap to Rudder)

-100~+0~+100
Initial value: -100

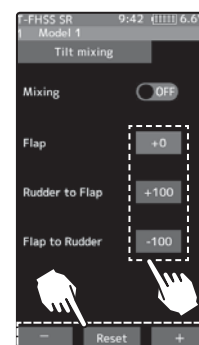

6 When finished, return to the Mixing menu screen by pressing the HOME button twice.

Dial / Trim Setting

The mixing rate amount can be controlled with digital dial or digital trim, using the dial select function.(page 66)

Timer

Use the timer by selecting one of the four timers Up timer, Fuel down timer, Lap timer and Lap navigate timer.

Up timer function

- The Up timer can be used to count the time between start and stop, etc.
- The timer repeatedly starts and stops each time the switch is operated and accumulates the time between each start and stop. (When the count reaches 99 minutes 59 seconds, it returns to 00 minutes 00 seconds and repeats the count.)
- The first start operation can be linked to the throttle trigger.
- An alarm sound can be set. The passage of time is announced by sounding of a buzzer (beeps) each minute after starting.

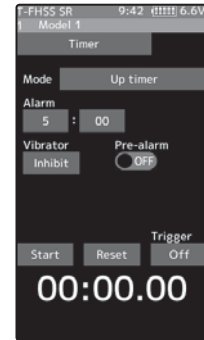

- Alarm :Generates a beep at the set time (minutes).
- Pre-alarm :Alarm advance announcement sound. Sounding begins 10 seconds before the set alarm time.

- After starting, the timer is enabled and can be stopped by switch even when the display switches to another screen.

Fuel down timer function

- The Up timer can be used to count the time between start and stop, etc.
- The timer repeatedly starts and stops each time the switch is operated and accumulates the time between each start and stop. (When the count reaches 99 minutes 59 seconds, it returns to 00 minutes 00 seconds and repeats the count.)
- The first start operation can be linked to the throttle trigger.
- An alarm sound can be set. The passage of time is announced by sounding of a buzzer (beeps) each minute after starting.

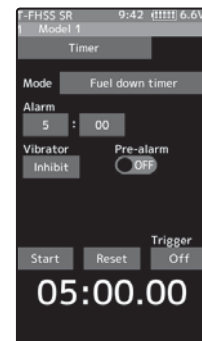

- Alarm :Generates a beep at the set time (minutes).
- Pre-alarm :Alarm advance announcement sound. Sounding begins 10 seconds before the set alarm time.

- After starting, the timer is enabled and can be stopped by switch even when the display switches to another screen.

Lap timer function

Lap timer function

- The Lap timer can memorize each lap time of each switch operation. (80 laps)
- The race time can be set. Switch operation after the set time by alarm has elapsed automatically stops the timer. Pre-alarm can also be set. The passage of time is announced by sounding of a buzzer (beeps) each minute after starting.

- Alarm :Generates a beep at the set time.
- Pre-alarm :Starts sounding the set time (second) before the alarm. (beeps)

- The first start operation can be linked with the throttle trigger.



(Lap timer operation)

- When lap timer is selected, the number of laps (LAP) and the lap memory No. (No.) and current lap time (TIME) are displayed on the setup screen.

- * LAP: Counted up each time the switch is pressed after starting. After the switch was pressed, the numbers pause for 3 seconds. To prevent erroneous counting, switch operation is not accepted during this time
- * Lap memory: The lap memory saves the lap times of 80 laps.
- * The lap time data stored in the lap memory can be checked at the lap list (page 134) screen.

Lap navigate timer function

Lap navigate timer function

- This function sounds a buzzer at a fixed interval after the timer starts. Since only the buzzer can be restarted when the switch is pressed during timer operation, this function can be used as the training run, etc. target time. (Lap navigation alarm) The passage of time is announced by sounding of a buzzer (beeps) every minute after starting.

- The first start operation can be linked with the throttle trigger.
- The alarm sounds (alarm/Pre-alarm) can be set separately from the fixed interval buzzer.

- Alarm :Generates a beep at the set time (minutes).
- Pre-alarm :Alarm advance announcement sound. Sounding begins 10 seconds before the set alarm time.

- After starting, the timer is enabled and can be stopped by switch even when the display switches to another screen.

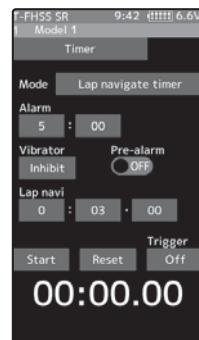

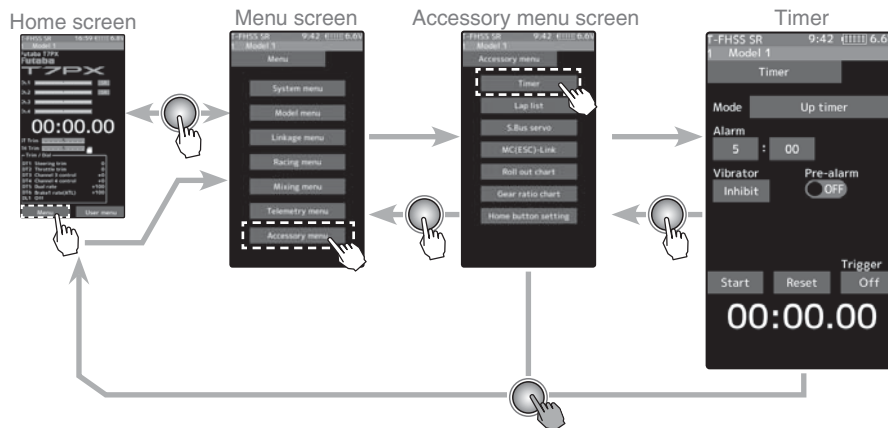

Time display
 Minute display (m)
 Second display (s)
 1/100 second display

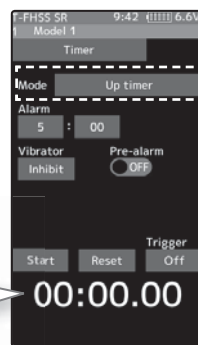

Timer selection
 First, select the type of timer at the "Mode" item. The setup screen varies depending on the type of timer. This figure shows the Up timer setup screen.

- Up timer
- Fuel down timer
- Lap timer
- Lap navigate timer

Racing timer type selection

(Preparation)

Assign the "Timer start" switch using the Switch select function (page 69). When resetting by switch, assign "Timer reset" also.

Setting type
 - Tap to select

- 1 (Racing timer type selection)
 Tap the "Mode". The mode list appears on the "Timer" menu screen, and tap the racing timer type.
 Up timer
 Fuel down timer
 Lap timer
 Lap navigate timer

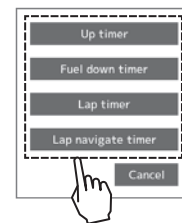
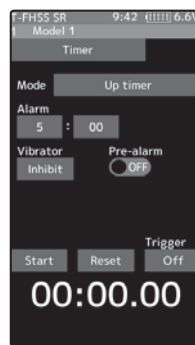

Function

- 2 When finished, return to the Accessory menu screen by pressing the HOME button.

Using the Up timer

(Preparation)

Select the "Up timer" from the timer type list and tap.

1 (Alarm time setting)

Tap the value button of the "Alarm time". Value input buttons appear on the screen. use the [+] and [-] buttons to set the time amount.

Tap [Vibrate] and select the vibration pattern of the alarm from 3 types of patterns and disable (OFF).

(Pre-alarm setting)

Tap (ON) or (OFF) of pre-alarm and select ON / OFF.

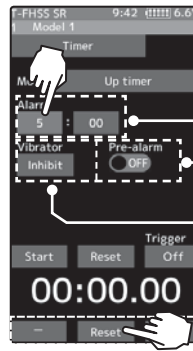

Alarm time

OFF, 1 ~ 99 minutes
Initial value: 5 minutes
- Adjust with the [+] and [-] buttons.
- Return to the initial value by tapping the [reset] buttons.

Pre-alarm time

OFF, ON
Initial value: OFF
- Tap (ON) / (OFF).

Grip vibrator type (pattern)

Inhibit(Off), Type1,2,3
Initial value: Inhibit
- Tap (ON) / (OFF).

2 (Timer start/stop operation)

When the switch (Timer start) assigned by switch select function is pressed, the timer starts. When you press the switch (Timer start) or [Start] / [Reset] on the screen during timer operation, the timer stops.

- Linking only start to the throttle trigger

Tap [OFF] of the trigger to display [Ready] and wait for the trigger operation. When you operate the trigger to the forward side, the timer starts. Stop is the same as when starting with a switch.

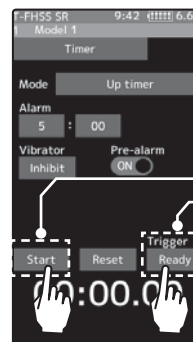

Start / Stop Status display

3 (Timer reset operation)

With the timer stopped, press the switch (timer reset) set by the Switch setting function, or tap [Reset] on the screen. The timer is reset with the beeping sound.

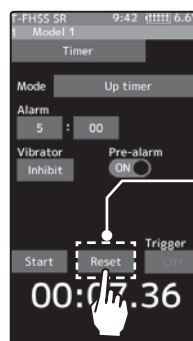

Timer reset

Using the fuel down timer

(Preparation)

Select the "Fuel down timer" from the timer type list and tap.

1 (Alarm time setting)

Tap the value button of the "Alarm time". Value input buttons appear on the screen. use the [+] and [-] buttons to set the time amount.

Tap [Vibrate] and select the vibration pattern of the alarm from 3 types of patterns and disable (OFF).

(Pre-alarm setting)

Tap (ON) or (OFF) of pre-alarm and select ON / OFF.

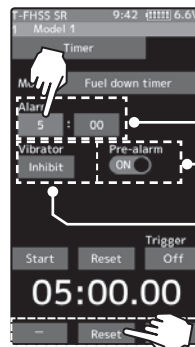

Alarm time

OFF, 1 ~ 99 minutes
Initial value: 5 minutes
- Adjust with the [+] and [-] buttons.
- Return to the initial value by tapping the [reset] buttons.

Pre-alarm time

OFF, ON
Initial value: OFF
- Tap (ON) / (OFF).

Grip vibrator type (pattern)

Inhibit(Off), Type1,2,3
Initial value: Inhibit
- Tap (ON) / (OFF).

2 (Timer start/stop operation)

When the switch (Timer start) assigned by switch select function is pressed, the timer starts.

When the switch ("Timer start") is pressed while the timer is operating, the timer is reset and simultaneously restarted. (Restart)

When you press the [Reset] on the screen during timer operation, the timer stops.

- Linking only start to the throttle trigger

Tap [OFF] of the trigger to display [Ready] and wait for the trigger operation. When you operate the trigger to the forward side, the timer starts. Stop is the same as when starting with a switch.

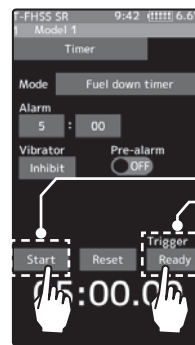

Start / Stop Status display

3 (Timer reset operation)

With the timer stopped, press the switch (timer reset) set by the Switch setting function, or tap [Reset] on the screen. The timer is reset with the beeping sound.

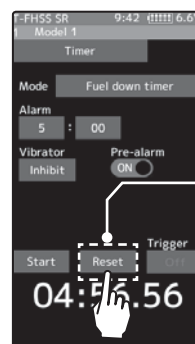

Timer reset

Using the lap timer

(Preparation)

Select the "Lap timer" from the timer type list and tap.

1 (Alarm time setting)

Tap the value button of the "Alarm time". Value input buttons appear on the screen. use the [+] and [-] buttons to set the time amount.

Tap [Vibrate] and select the vibration pattern of the alarm from 3 types of patterns and disable (OFF).

(Pre-alarm setting)

Tap (ON) or (OFF) of pre-alarm and select ON / OFF.

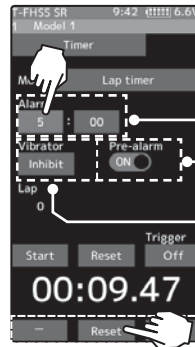

Alarm time

OFF, 1 ~ 99 minutes
Initial value: 5 minutes
- Adjust with the [+] and [-] buttons.
- Return to the initial value by tapping the [reset] buttons.

Pre-alarm time

OFF, ON
Initial value: OFF
- Tap (ON) / (OFF).

Grip vibrator type (pattern)

Inhibit(Off), Type1,2,3
Initial value: Inhibit
- Tap (ON) / (OFF).

2 (Timer start operation)

Perform the start and lap count operations with the switch ("Timer start") assigned by function select switch function.

- Linking only start to the throttle trigger

Tap [OFF] of the trigger to display [Ready] and wait for the trigger operation. When you operate the trigger to the forward side, the timer starts. Stop is the same as when starting with a switch.

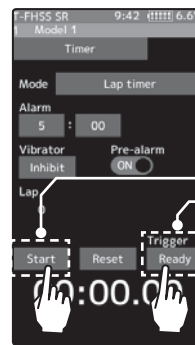

Start / Stop Status display

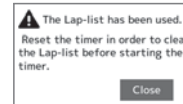

3 (Timer stop and lap reset operation)

When the lap count switch or ("Timer reset") switch is pressed after the time set by "Alarm" has elapsed and the lap time, total time, and average lap time are saved and checked. (Lap list page 134) If the switch ("Timer reset") set by switch setting function is pressed, the timer is reset.

When a switch is not set, tap [Reset] on the screen. The timer is reset with the beeping sound.

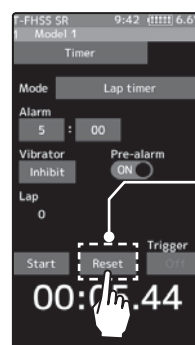

Timer reset

Using the lap navigate timer

(Preparation)

Select the "Lap navigate timer" from the timer type list and tap.

1 (Alarm time setting)

Tap the value button of the "Alarm time". Value input buttons appear on the screen. use the [+] and [-] buttons to set the time amount.

Tap [Vibrate] and select the vibration pattern of the alarm from 3 types of patterns and disable (OFF).

(Pre-alarm setting)

Tap (ON) or (OFF) of pre-alarm and select ON / OFF.

(Lap navigation time setting)

Tap the value button of the "Lap navi". Value input buttons appear on the screen. use the [+] and [-] buttons to set the time amount.

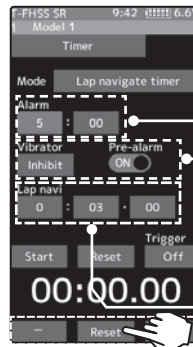

Alarm time

OFF, 1 ~ 99 minutes
Initial value: 5 minutes
- Adjust with the [+] and [-] buttons.
- Return to the initial value by tapping the [reset] buttons.

Pre-alarm time

OFF, ON
Initial value: OFF
- Tap (ON) / (OFF).

Grip vibrator type (pattern)

Inhibit(Off), Type1,2,3
Initial value: Inhibit
- Tap (ON) / (OFF).

Navi alarm time (NAVI)

OFF, 1 ~ 99 seconds
Initial value: 3 seconds

2 (Timer start / navigation restart operation)

When the switch ("Timer start") assigned by switch select function is pressed, the timer starts.

- Linking only start to the throttle trigger

Tap [OFF] of the trigger to display [Ready] and wait for the trigger operation. When you operate the trigger to the forward side, the timer starts. Stop is the same as when starting with a switch.

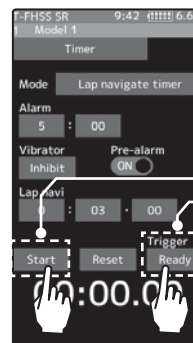

Start / Stop Status display

When your own lap time is less than the target time and the lap counts overlap, the lap navigation alarm timing is too big. The alarm timing can be corrected by pressing the switch ("Timer start") during measurement.

3 (Timer stop / reset operation)

Press the switch ("Timer reset") set by the Switch setting function, or tap [Reset] on the screen. The timer is stops.

With the timer stopped, press the switch ("Timer reset") set by the Switch setting function, or tap [Reset] on the screen. The timer is reset with the beeping sound.

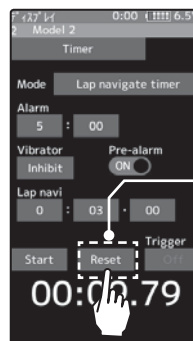

Timer reset

Lap List

Call Lap list when checking the lap memory data (each lap time) memorized by lap timer (page 132) operation.

- After the lap timer is started, the lap time is sequentially memorized at each switch operation.

-The total time and average time are displayed. The faster time is displayed in red characters.

-Lap time data is saved in each model data.

-Up to 80 laps can be saved.

-If the lap timer is reset, the lap list is also cleared.

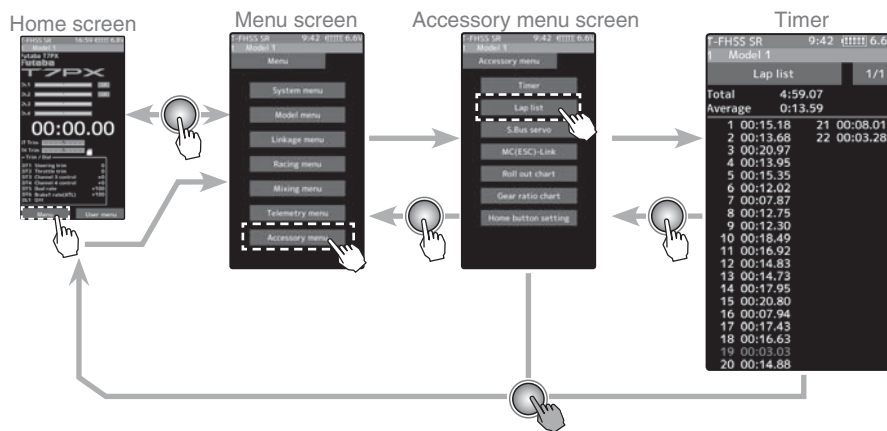

Using the lap memory

1 (Lap memory check)

The lap time list displays 40 laps per page and 80 laps maximum on 2 pages. If there is a list on page 2, tap [1/2] / [2/2] at the upper right of the screen to change the display of the page.

2 When finished, return to the Accessory menu screen by pressing the HOME button.

S.Bus Servo

This is a special function which allows Futaba S.BUS/S.BUS2 servo parameter changes to be set by the T7PX transmitter. However, some data changes require a PC and S-Link software. This function is used by connecting Futaba S.BUS/S.BUS2 servo directly to the transmitter. Use the various optional servo extension cords according to the distance between the transmitter and servo. (SR mode setting is for T7PX only, it can not be set with S-Link software.)

-If shutting off while writing the parameters, the servo may fail. Please use this function with sufficient battery power.

-Power is supplied to the servo from the transmitter, but the corresponding voltage is for high voltage servo (HV) use. Since an overvoltage will be applied to servos other than this, connect the corresponding battery to the servo. When the battery is connected, the supply of power from the transmitter automatically stops.

⚠ Caution

❗ When connecting an S-BUS servo that does not support high voltage, connect a battery matched to the servo specifications.

High voltage servo support voltage is supplied from the transmitter. If a servo that does not support high voltage is connected, unreasonable force will be applied to the servo and will cause trouble.

🚫 Do not disconnect the servo connector or turn off the transmitter power while writing parameters. It may cause the servo to malfunction.

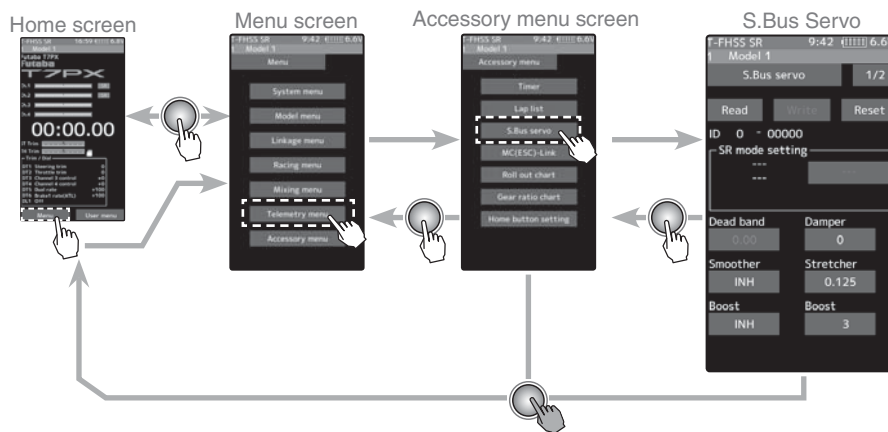
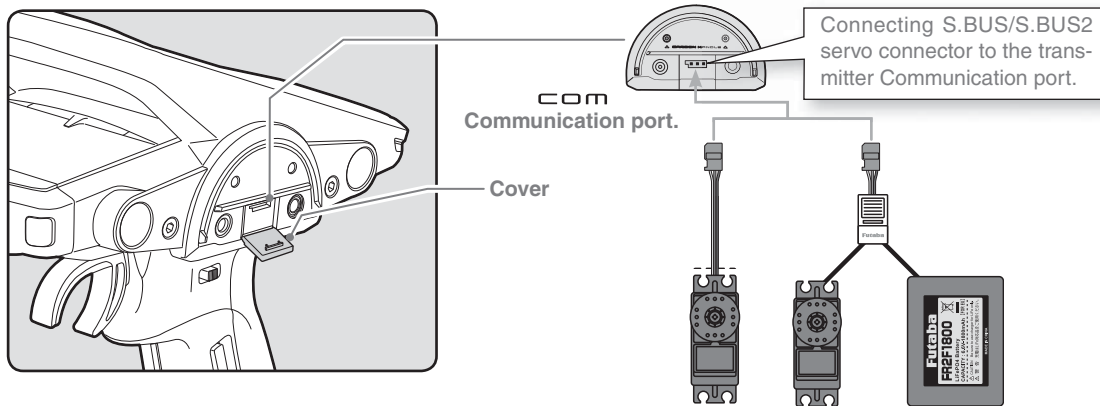

S.Bus Servo

Using the S.Bus servo function

(Preparation)

- Connect the T7PX and S.BUS or S.BUS2 servo in accordance with the connection diagram shown on page 135.
- Connect the battery to a non-high voltage(HV) support S.BUS/S.BUS2 servo.

1 Turn power on the transmitter. "S.Bus servo" menu is displayed referring to the map of page135.

2 (S.BUS/S.BUS2 servo read)

Execute this function to read the connected servo type and the data currently set at the servo. Tap the [Read]. The confirmation screen will be displayed. To execute, tap [Yes] to hear an electronic sound and finish setting. To cancel, select [No] and touch it.

- "Reading succeeded" is displayed on the screen and the servo's ID cord and currently set contents are read.

- If "Failed" is displayed on the screen, communication with the servo is not being performed normally. Check the T7PX and servo connection to servo and repeat [Read]. (Connect the battery to a non-high voltage(HV) support servo.)

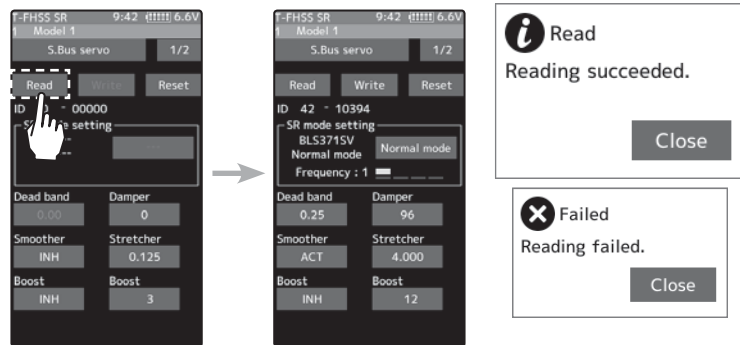

3 (Writing to S.BUS/S.BUS2)

Execute this function to write the setting data to servo. See pages 138 to139 for the setting data contents. Tap the [Write]. The confirmation screen will be displayed. To execute, tap [Yes] to hear an electronic sound and finish setting. To cancel, select [No] and touch it.

- "Writing succeeded" is displayed on the screen and the setting data is written to servo.

- If "Failed" is displayed on the screen, communication with the servo is not being performed normally. Check the T7PX and servo connection to servo and repeat [Write]. (Connect the battery to a non-high voltage(HV) support servo.)

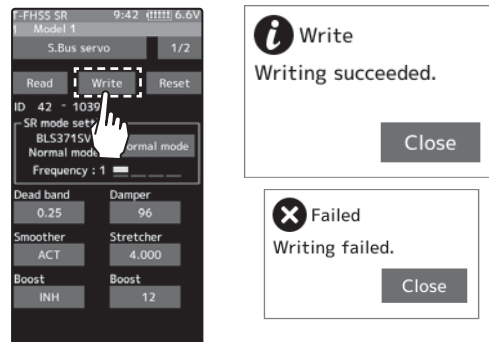

4 (Initialization)

Write the factory set servo setting data to the connected servo. Tap the [Reset]. The confirmation screen will be displayed. To execute, tap [Yes] to hear an electronic sound and finish setting. To cancel, select [No] and touch it.

- "Writing succeeded" is displayed on the screen and the setting data is written to servo.

- If "Failed" is displayed on the screen, communication with the servo is not being performed normally. Check the T7PX and servo connection to servo and repeat "Write". (Connect the battery to a non-high voltage(HV) support servo.)



Display data list

- The type and data of the loaded servo are displayed. Since there are two setting items, change the page as follows.

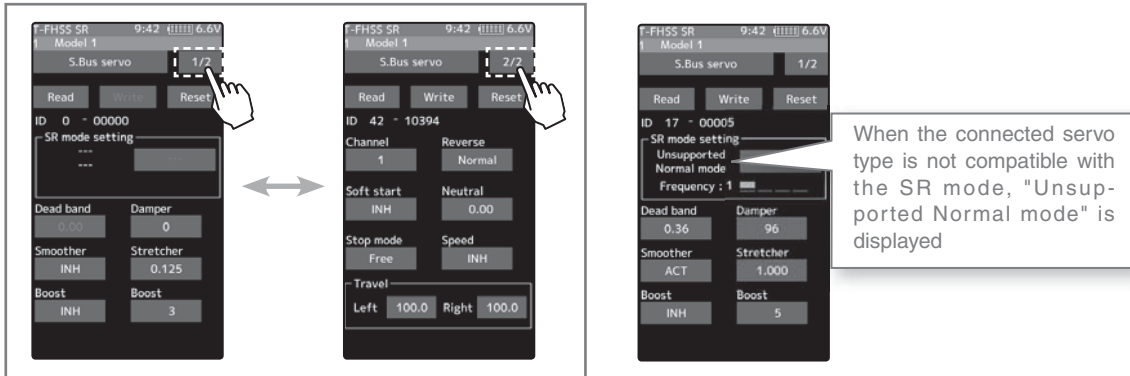

- Do not plug in or disconnect servos, or connect other servos while keeping the screen where data was read by [Read]. Be sure to connect the servo in the state where [Write] or [Reset] is finished, or press the Home button to access the accessory menu screen.
- The loaded data can not be written to another servo.

SR mode setting

- (Writing to servo)

Tap [SR mode] or [Normal mode] of SR mode setting. A confirmation screen of "Notes on SR setting" is displayed, so read carefully and tap [Normal mode] or [SR mode].

- When [Normal mode] is selected, "Writing succeeded" is displayed on the screen, and the setting data is written to the servo.
- If "Failed" is displayed, communication with the servo is not performed normally. Check the connection between the T7PX and the servo, and then execute the write operation again.

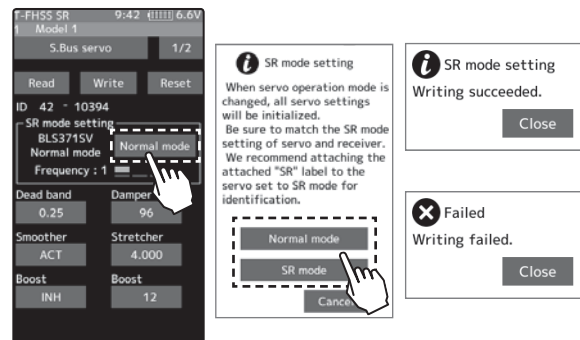

- (When SR mode is selected by writing to servo)

In the confirmation screen of "Notes on SR setting", tap [SR mode], the screen for selecting the SR type is displayed. Three types with different feeling are prepared. (Please repeat the test and choose the type.)

- "Writing succeeded" is displayed on the screen and the setting data is written to the servo. If "Failed" is displayed, communication with the servo is not performed normally. Check the connection between the T7PX and the servo, and then execute the [Write] operation again.
- For the servo set to SR mode, affix the attached SR label so that the mode can be recognized.

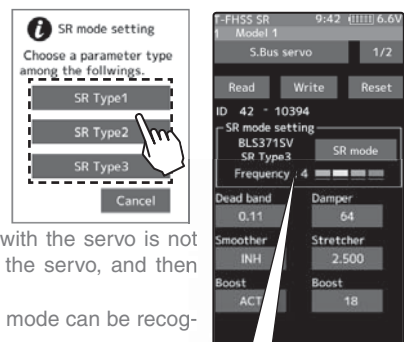

The type of servo and the set SR type are displayed.

- ⊘ Do not connect absolutely to the S. BUS channel of all receivers for the servo set to SR mode. The servo will fail.

S.BUS function setup

- 1 On the setting screen of each function, if you tap the item to be set, [-] [reset] [+] will be displayed at the bottom of the screen, tap the [-] [+] on the panel Set. Tap [Reset] to return to the initial value. There are items with no [reset]. In case of selection type, data is switched by tapping an item.

ID
Displays the ID of the servo whose parameters are to be read. It cannot be changed.

Dead band

The dead band angle at stopping can be specified.

[Relationship between dead band set value and servo operation]

Small - Dead band angle is small and the servo is immediately operated by a small signal change.

Large - Dead band angle is large and the servo does not operate at small signal changes.

(Note) If the dead band angle is too small, the servo will operate continuously and the current consumption will increase and the life of the servo will be shortened.

Damper

The characteristic when the servo is stopped can be set.

When smaller than the standard value, the characteristic becomes an overshoot characteristic. If the value is larger than the standard value, the brake is applied before the stop position.

Especially, when a large load is applied, overshoot, etc. are suppressed by inertia and hunting may occur, depending on the conditions. If hunting (phenomena which cause the servo to oscillate) occurs even though the Dead Band, Stretcher, Boost and other parameters are suitable, adjust this parameter to a value larger than the initial value.

[Relationship between damper set value and servo operation]

Small - When you want to overshoot. Set so that hunting does not occur.

Large - When you want to operate so that braking is not applied. However, it will feel like the servo response has worsened.

(Note) If used in the hunting state, not only will the current consumption increase, but the life of the servo will also be shortened.

Smoother

This function makes servo operation smooth. Set it according to your taste. Normally set it to "ACT". Set it to "INH" when want especially quick operation. When the smoother function was set to "ACT" and the servo was operated the distance up to the target position is changed in steps so movement is smooth.

Stretcher

The servo hold characteristic can be set. The torque which attempts to return the servo to the target position when the current servo position has deviated from the target position can be adjusted.

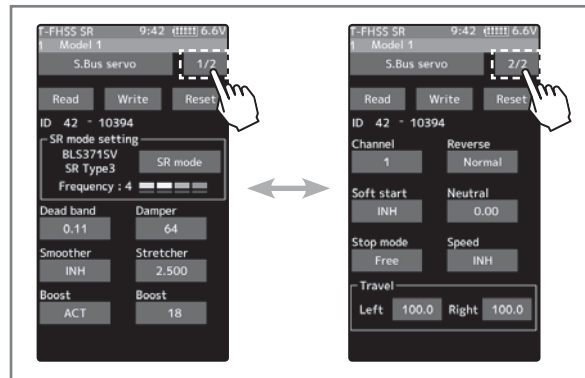

This is used when stopping hunting, etc., but the holding characteristic changes as shown below.

[Relationship between stretcher and servo operation]

Small - Servo holding force becomes weaker.

Large - Servo holding force becomes stronger.

(Note) When this parameter is large, the current consumption increases.

Boost/Boost (ON/OFF)

INH : It is the boost ON at the time of low-speed operation. (In the case of usual)

ACT : It is always the boost ON. (When quick operation is hope).

The minimum current applied to the internal motor when starting the servo can be set. Since a small travel does not start the motor, it essentially feels like the dead band was expanded. The motor can be immediately started by adjusting the minimum current which can start the motor.

[Relationship between boost set value and servo operation]

Small - Motor reacts to a minute current and operation becomes smooth.

Large - Initial response improves and output torque increases. However, if the torque is too large, operation will become rough.

Channel

This is the S.BUS system channel assigned to the servo. When connected to the receiver S-BUS2 connector as an S.BUS system, the channel used by the transmitter is assigned. When the normal receiver channel is used, channel setting is unnecessary.

Reverse

The direction in which the servo rotates can be changed.

Soft Start

Restricts operation in the specified direction the instant the power is turned on. By using this setting, the first initial movement when the power is turned on slowly moves the servo to the specified position.

Neutral

The neutral position can be changed. When the neutral offset is large value, the servo's range of travel is restricted on one side.

Stop Mode

The state of the servo when the servo input signal is lost can be specified. The "Hold" mode setting holds the servo in its last commanded position even if using AM or FM system.

Speed

Speeds can be matched by specifying the operating speed. The speed of multiple servos can be matched without being affected by motor fluctuations. This is effective for load torques below the maximum torque.

However, note that the maximum speed will not be exceed what the servo is capable of even if the servos operating voltage is increased.

Travel [Left] / [Right]

The maximum left and right travels centered about the neutral position can be set independently.

MC Link (ESC Link)

This is a special function which allows Futaba motor controller (MC) data changes to be set by the T7PX transmitter (MC960CR, MC950CR, MC851C, MC602C, MC402CR, etc.).

However, some data changes require a PC and Link software.

This function is used by connecting ESC directly to the transmitter.

Use the various optional servo extension cords according to the distance between the transmitter and ESC.

-Also connect the battery at the ESC side.

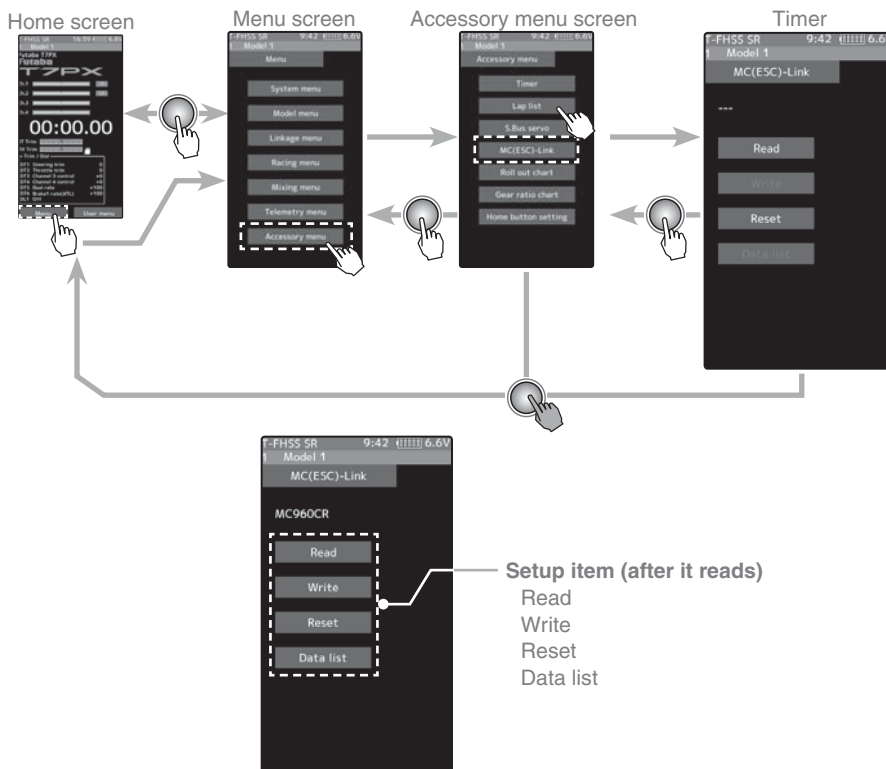
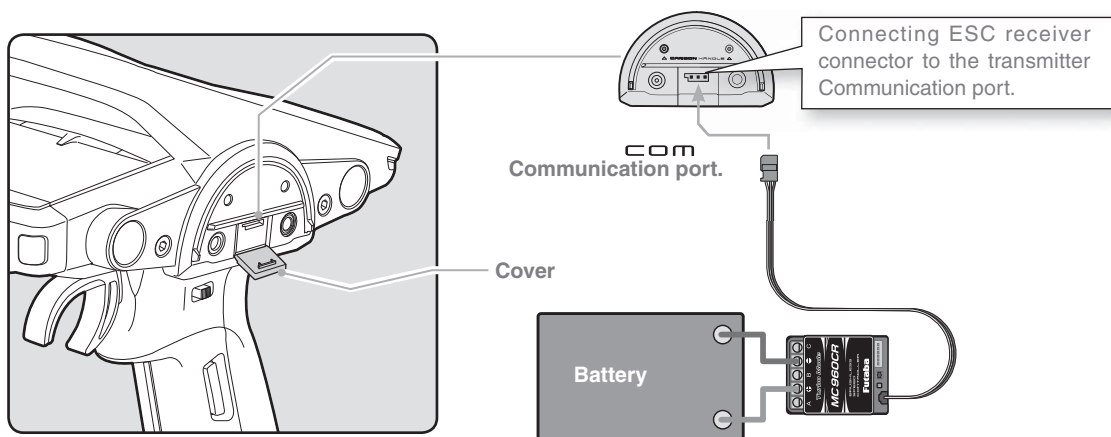

Function

Using the ESC Link function

(Preparation)

- Connect the T7PX and ESC in accordance with the connection diagram shown on page 140.
- Connect the battery to ESC.

1 Turn power on the transmitter. "MC link" menu is displayed referring to the map of page 140. Set the FET amp power switch to the ON position.

2 (ESC read)

Execute this function to read the connected ESC type and the data currently set at the ESC. Tap the [Read]. The confirmation screen will be displayed. To execute, tap [Yes] to hear an electronic sound and finish setting. To cancel, select [No] and touch it.

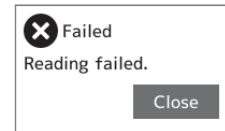
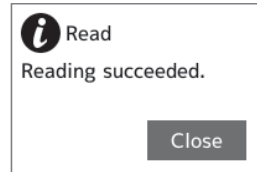
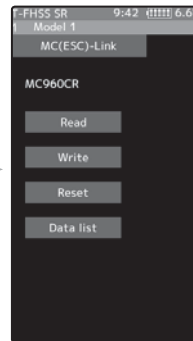
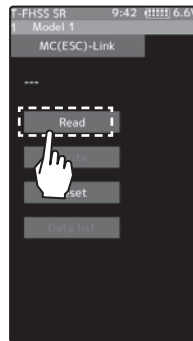

- "Reading succeeded" is displayed on the screen and the ESC type and currently set contents are read.
- If "Failed" is displayed on the screen, communication with the ESC is not being performed normally. Check the T7PX and ESC connection and the battery connection to ESC and the ESC power switch and repeat [Read].

3 (Writing to ESC)

Execute this function to write the setting data to ESC. See pages 143 to 148 for the setting data contents. Tap the [Write]. The confirmation screen will be displayed. To execute, tap [Yes] to hear an electronic sound and finish setting. To cancel, select [No] and touch it.

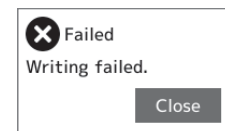
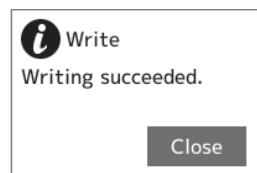
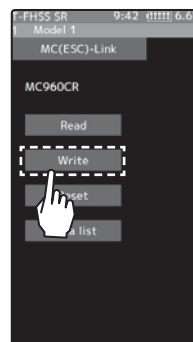

- "Writing succeeded" is displayed on the screen and the setting data is written to ESC.
- If "Failed" is displayed on the screen, communication with the ESC is not being performed normally. Check the T7PX and ESC connection and the battery connection to ESC and the ESC power switch and repeat [Write].
- Different type ESC data cannot be written. If writing is attempted, "Failed" is displayed on the screen.

4 (Initialization)

Write the factory set ESC setting data to the connected ESC. Tap the [Reset]. The confirmation screen will be displayed. To execute, tap [Yes] to hear an electronic sound and finish setting. To cancel, select [No] and touch it.

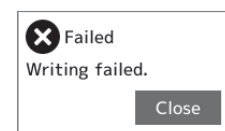
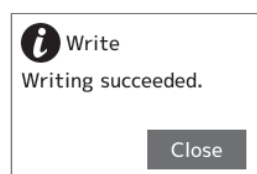
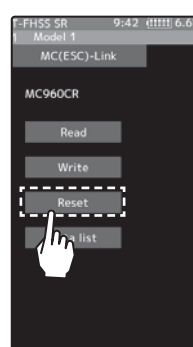

- "Writing succeeded" is displayed on the screen and the setting data is written to ESC.
- If "Failed" is displayed on the screen, communication with the ESC is not being performed normally. Check the T7PX and ESC connection and the battery connection to ESC and the ESC power switch and repeat [Write].

Display data list

-ESC is read referring to the explanation of page 139.

1 Tap the [Data list].

Depending on the ESC type, the setting items are different.

If there are multiple pages, move the page as follows.

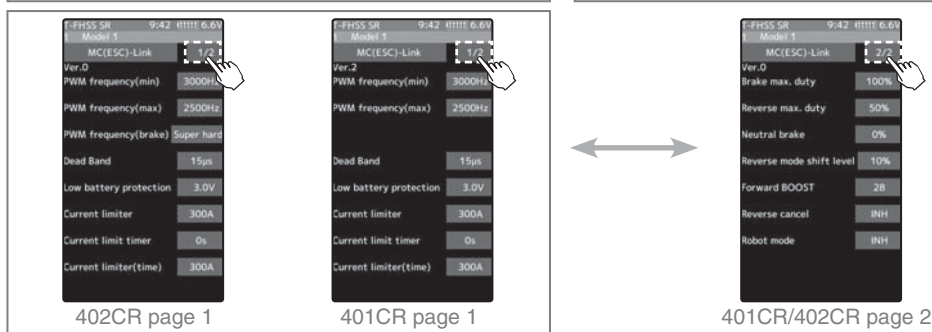
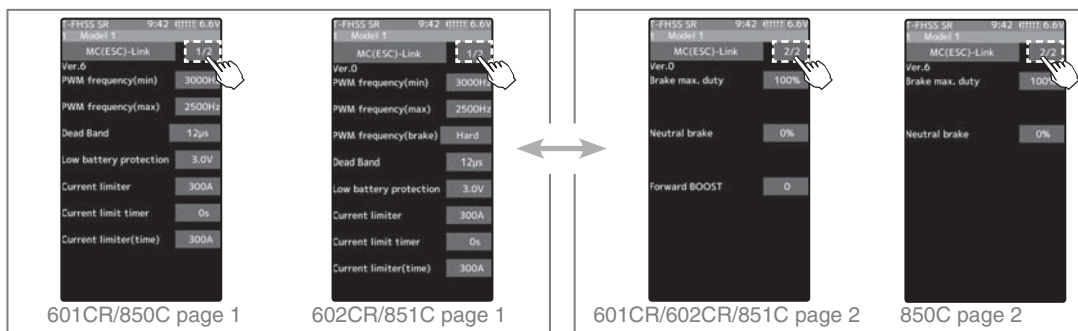
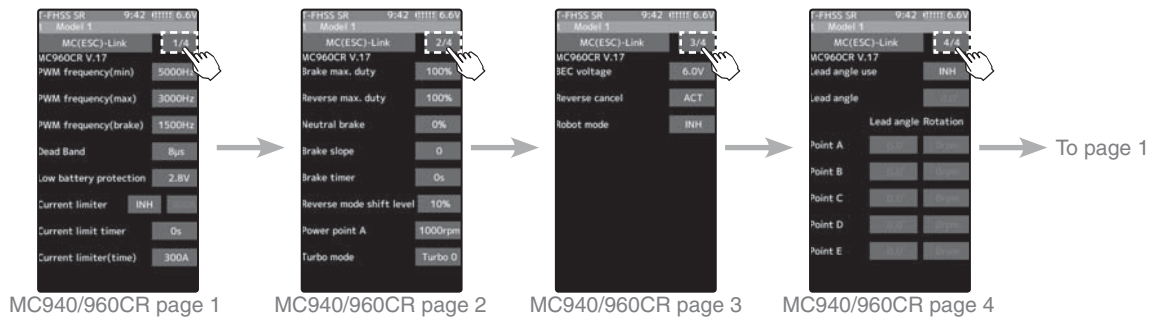
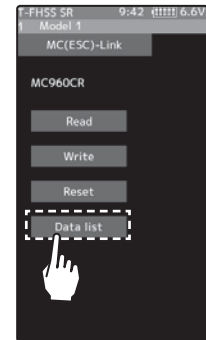

Function

PWM frequency (min)

MC401,402CR/601,602C/850,851C :0.1kHz(100Hz) 10kHz (10000Hz)
 MC950CR :0.5kHz(500Hz) 30kHz(30000Hz)
 MC940,960CR :1kHz(1000Hz) 30kHz(30000Hz)

Same as Link software PWM frequency (at Min. load),

MIn sets the "0" PWM frequency at minimum load.

PWM frequency (max)

MC401,402CR/601,602C/850,851C:0.1kHz(100Hz) 10kHz (10000Hz)
 MC950CR:0.5kHz(500Hz) 30kHz(30000Hz)
 MC940,960CR:1kHz(1000Hz) 30kHz(30000Hz)

Same as Link software PWM frequency (at Max. load).

MAX sets the PWM frequency at maximum load at the output current limit value set by Current Limiter.

PWM frequency (brake)

MC402CR/602C/851C (MC401,601,850 cannot be adjusted 2kHz fixation)
 :Normal(2000Hz) /Hard(1000Hz) /Super hard(500Hz)

MC950CR :0.5kHz(500Hz)30kHz(30000Hz)

MC940,960CR :1kHz(1000Hz)30kHz(30000Hz)

Same as Link software Brake PWM at frequency.

This setting can set the brake PWM frequency.

"min" which sets the frequency when the load is small, is set to the high frequency side (large value) when extension is desired after straightaways and curves.

"max" which sets the frequency when the load is large, is set to the high frequency side (large value) when you want to suppress the rise from low speed and when motor heating and commutator roughness are sensed.

When the rise from low speed is poor, and becomes bad even when "max" is set to the low frequency side, use the log data to check if there was a momentary voltage drop. When you want to suppress the overall power, lengthen the run time, and otherwise improve efficiency, set both "max" and "min" to the high frequency side. When you want to set a fixed PWM frequency at full range regardless of the load current, set PWM frequency (at Max. load) and PWM frequency (at Min. load) to the same value.

T-FHSS SR 9:42 6.8V	
Model 1	
MC(ESC)-Link	1/4
MC960CR V.17	
PWM frequency(min)	5000Hz
PWM frequency(max)	3000Hz
PWM frequency(brake)	1500Hz
Dead Band	8µs
Low battery protection	2.8V
Current limiter	INH 300A
Current limit timer	0s
Current limiter(time)	300A
- Reset +	

Dead Band

All type :±2µs~±50µs

Same as Link software Dead Band.

This sets the range (neutral point range) over which the ESC does not respond to transmitter throttle operation.

The larger the set value, the wider this range.

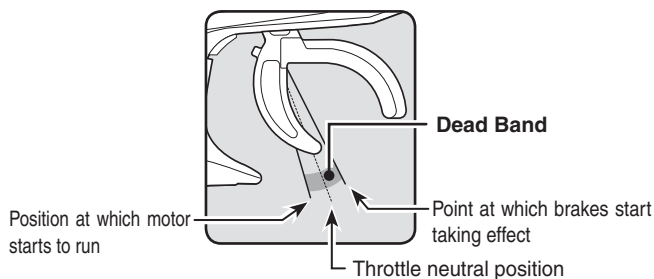

MC Link (ESC Link)

T-FHSS SR 9:42 6.8V	
Model 1	
MC(ESC)-Link	1/4
MC960CR V.17	
PWM frequency(min)	5000Hz
PWM frequency(max)	3000Hz
PWM frequency(brake)	1500Hz
Dead Band	8µs
Low battery protection	2.8V
Current limiter	INH 300A
Current limit timer	0s
Current limiter(time)	300A

Low battery protection

MC401,402CR/601,602C/850,851C:2.5V 6.0V

MC950CR/MC940,960CR 2.5V 7.5V

Same as Link software Low Bat Protection.

When the power supply voltage drops, the output current to the motor is limited and supply voltage to the receiver is ensured. When the power supply voltage drops to the set voltage, a protection circuit operation alarm is activated and output to the motor is cut. The protection circuit is automatically reset by recovery of the power supply voltage

MC(ESC)-Link	1/4
MC960CR V.17	
PWM frequency(min)	5000Hz
PWM frequency(max)	3000Hz
PWM frequency(brake)	1500Hz
Dead Band	8µs
Low battery protection	2.8V
Current limiter	INH
Current limit timer	0s
Current limiter(time)	300A

Current limiter

MC401,402CR/601,602C/850:50A 300A, INH

MC851C :50A~300A(can not INH)

MC950CR/MC940,960CR:50A~500A, INH

Same as Link software PWM frequency (at Max. load).

MAX sets the PWM frequency at maximum load at the output current limit value set by Current Limiter.

Current limiter INH/ACT setting

MC950CR and MC940 / 960CR tap INH OR ACT by tapping the current limiter INH/ACT.

The MC851C does not have an INH(Off) settin

Current limit timer

MC401,402CR/601,602C/850,851C:0sec(OFF)240sec

MC940,960CR:0sec(OFF)~240sec (MC950CR can not)

Same as Link software Current Limit timer.

The output current can be limited up to the set time lapse from the start of running. This is effective in preventing the motor from outputting wasted energy when the voltage is high immediately after the power battery was recharged.

"Current Limiter (time)" sets the time the output current is limited. This function is disabled when set to "0" sec.

Since the Current Limit Timer starts when the throttle is operated to the forward side and current is output to the motor, this function begins to operate when the motor is run during trim adjustment, etc.

Current limiter (time)

MC401,402CR/601,602C/850,851C :50A~300A

MC940,960CR :50A~500A (MC950CR can not)

"Current Limit timer" sets the maximum output current within the time the output current is limited.

MC(ESC)-Link	1/4
MC960CR V.17	
PWM frequency(min)	5000Hz
PWM frequency(max)	3000Hz
PWM frequency(brake)	1500Hz
Dead Band	8µs
Low battery protection	2.8V
Current limiter	INH
Current limit timer	0s
Current limiter(time)	300A

MC(ESC)-Link	1/2
Ver.0	
PWM frequency(min)	3000Hz
PWM frequency(max)	2500Hz
PWM frequency(brake)	Super hard
Dead Band	15µs
Low battery protection	3.0V
Current limiter	300A
Current limit timer	0s
Current limiter(time)	300A

Brake max. duty

All type :0%~100%

Same as Link software Brake Max. Duty.

This setting can set the braking force between the neutral point and Max brake point.

The larger this value, the greater the braking force. When set to "0%", the brakes are not effective.

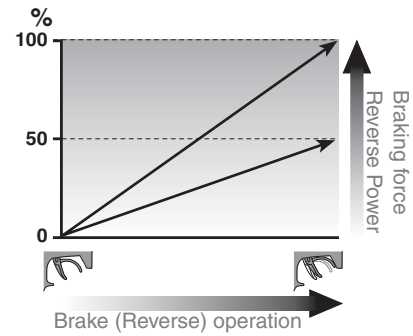

Reverse max. duty

MC401,402CR/MC950CR/MC940,960CR :0%~100%

Same as Link software Reverse Max. Duty.

This setting can set the reverse power between the neutral point and Max reverse point.

The larger this value, the greater the reverse power. When set to "0%", the reverses are not effective.

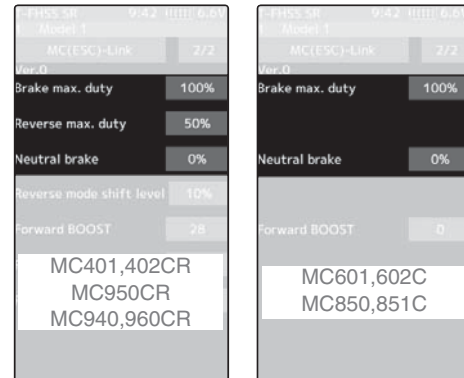

Neutral brake

All type :0%~100%

Same as Link software Current Limit timer.

Make this setting when you want to use the brakes at the neutral throttle (OFF) position by throttle operation. The larger this value, the greater the braking force. When you want to use the neutral brake, set this value to "0%".

Reverse mode shift level

MC401,402CR/MC950CR/MC940,960CR :0%~100%

Same as Link software Reverse Mode Shift Level.

The reverse operation can be done with the throttle trigger to be thrown from brake status to the neutral. The value can set the amount of the brake in order to switch to the reverse operation.

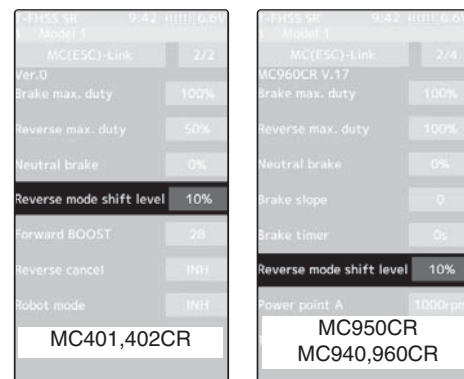

Forward BOOST

MC401,402CR/MC601,602C/MC851C :0%~100%

Same as Link software Forward Boost (Boost).

Operation near the throttle trigger neutral position becomes a sharp rise.

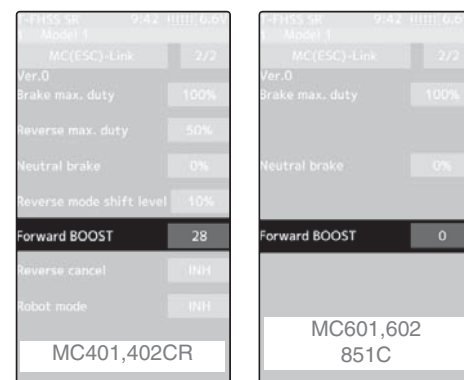
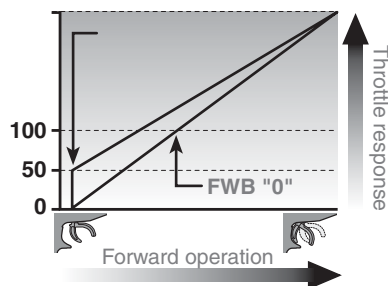

Function

Reverse cancel

MC401,402CR/MC950CR/MC940,960CR :ACT/INH

Same as Link software Reverse Cancel.

When set to "ACT", reverse operation is not performed.

Robot mode

MC401,402CR/MC950CR/
MC940,960CR :ACT/INH

Same as Link software Robot Model.

When set to "ACT", brake operation is not performed, there is only forward and reverse operation.

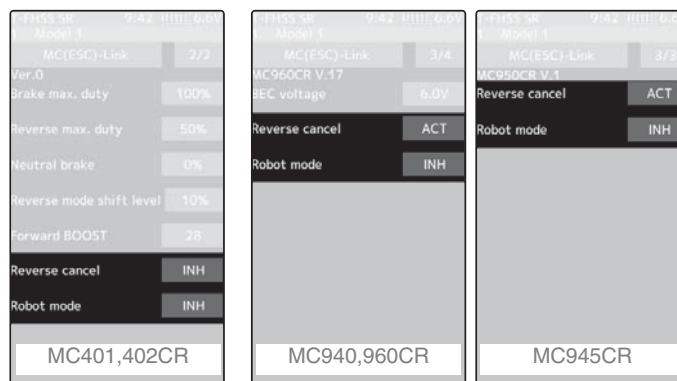

Brake slope

MC940,960CR/ :0~300

Same as Link software Brake Slope.

This function adjusts the braking effect when the throttle was returned (throttle off). It cancels operation like that called engine brake of actual vehicles.

Brake timer

MC940,960CR/MC950CR :0sec~300sec

Same as Link software Brake Timer.

When the reverse function is used, ordinarily if the trigger is not moved to the brake (reverse) side and then returned from the brake operation position to the neutral position, reverse operation will not be performed. However, when used by intentionally moving the neutral point to the forward side, if brake operation is repeated, reverse operation may be performed even if the trigger is not returned to the neutral position. The time required to switch to reverse operation can be set to prevent this from occurring.

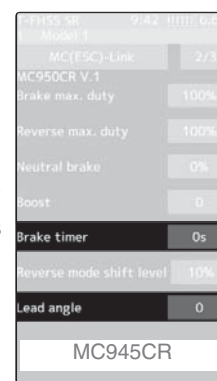
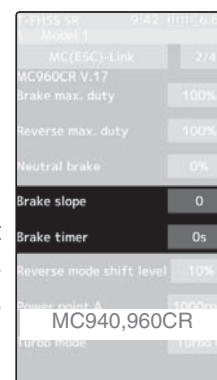

Lead angle

MC950CR/ :0~1500

Same as Link software Lead Angle.

The lead angle of the motor can be set at the MC950CR side. However, we recommend that it normally be set to "0". Since this setting is premised on setting by referring to the speed log by the Link software.

BEC voltage

MC940,960CR/ :6.0V/7.4V

Same as Link software BEC Volt.

The receiver BEC voltage can be selected from 6.0V and 7.4V. Match the voltage to the rating of the servo connected to the same receiver. This BEC voltage cannot output a voltage higher than the input voltage. For instance, if a 6.0V receiver and servo are used with a power supply voltage of 7.4V or more, set the BEC voltage to 6.0V and when a high voltage receiver and servo are used, set the BEC voltage to 7.4V.

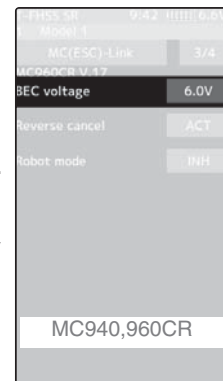

Turbo mode

MC940,960CR/ :Turbo0/Turbo1/Turbo2

Same as Link software Turbo Mode.

This function sets the turbo mode. More power can be displayed by using the turbo mode. Depending on the setting, the motor and ESC may be damaged so make this setting carefully.

(Note) When "Lead angle use" is INH, lead angle setting will not operate even if set to "Turbo1" or "Turbo2". (Turbo mode disabled, Turbo0=Off)

-Turbo0 mode: (No Lead Angle mode) Lead angle - No

When used in races in which the lead angle setting function is inhibited by ESC, set to this mode. The lead angle function is disabled the same as if "Lead angle use" was turned off.

When the lead angle function was disabled by the method described above, the MC940,960CR shows that the lead angle function is off by blinking a blue LED at an ON 0.1 second, OFF 0.9 second cycle at the neutral point.

-Turbo1 turbo mode: (Lead Angle mode) Lead angle – Yes

The output can be increased by setting a lead angle.

Depending on the set value, the motor may be damaged so increase the lead angle value in steps from a small value while observing the conditions.

Turn on "Lead angle use" and adjust the lead angle by "Lead angle" and point B, C, D, E (A, B, C, D, E Lead angle) value.

-Turbo2 power mode: (Power Mode) Lead angle – Yes

Displays still more power than a turbo.

However, since even a motor applies a large load on the ESC, make the lead angle larger in steps from a small value while observing the conditions.

Turn on "Lead angle use" and adjust the lead angle by "Lead angle" and point A, B, C, D, E (A, B, C, D, E Lead angle) value.

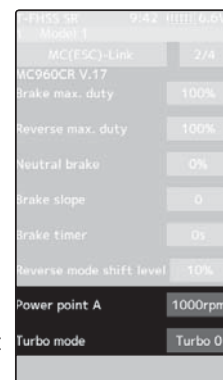

A,

Function

Power point A

MC940,960CR/ :6.0V/7.4V

Same as Link software Power Point A.

When the turbo mode is power 2 (Power mode) and the lead angle is large, movement may become stiff when entering the course, etc. In this case, make operation smooth by lowering the set speed at power point A.

This function is not performed in modes other than Turbo 2.

Lead angle use

MC940,960CR :ACT/INH

Same as Link software Lead Angle Use.

This function is effective when Turbo Mode is Turbo1 or Turbo2 and sets whether or not lead angle is used. This setting has priority over the Turbo Mode setting. When using in races in which the lead angle function is inhibited by the ESC set this function to INH.

INH : Lead angle function not used.
ACT : Lead angle used

Point A,B,C,D,E Lead angle

MC940,960CR :0deg~59deg

Same as Link software Boost Angle.

Point A,B,C,D,E Rotation

MC940,960CR :0rpm~120,000rpm

Same as Link software Boost Angle rpm.

When "Lead Angle Use" is turned on the lead angle versus motor speed of the 5 points A to E can be set. The lead angle can be set up to 59 degrees in 1 degree increments.

The "Lead angle" and "Point A, B, C, D, E Lead angle" relationship is shown on the graphs below. Graph [1] shows the relationship when the same value is set at "Points A, B, C, D, E Lead angle" of [1] and [2] and the "Lead angle" was set to "0" and graph [2] shows the relationship when a value other than "0" was set at "Lead angle". As shown in the graphs, [2] is added to the "Points A, B, C, D, E Lead angle" set lead angle and [1] is added to the "Lead angle" set lead angle. For example, if "3" is set at Point A and "Lead angle" of [2] is set to "2", the actual Point A becomes $3+2=5$ (deg). Since "Lead angle" of [A] is "0", the actual Point A also becomes $3+0=3$ (deg).

Turn on "Lead angle use"

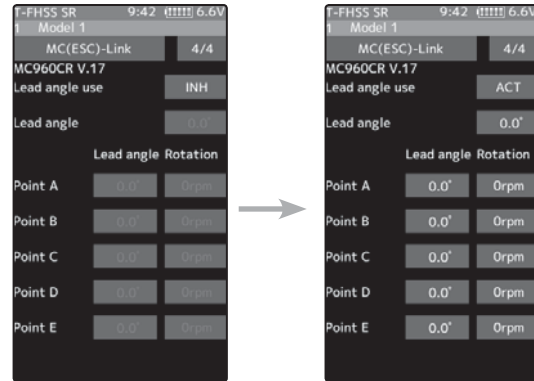

Function

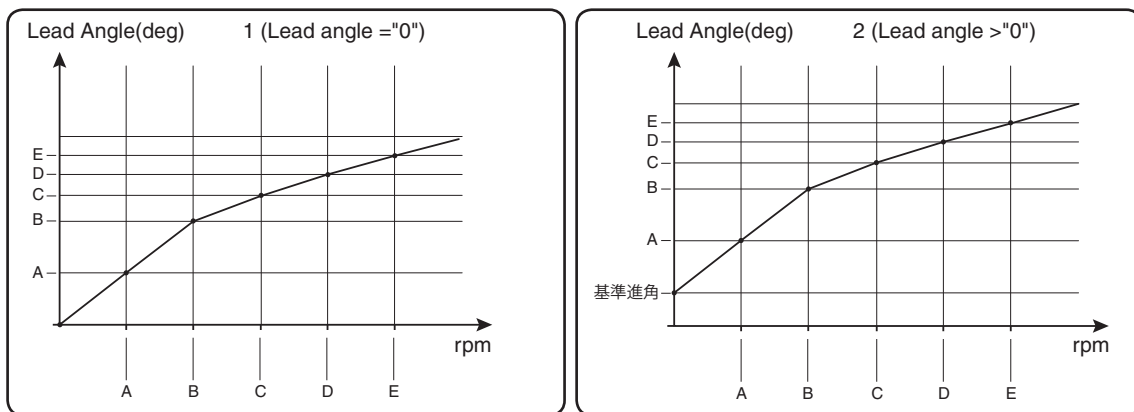

When using in races in which the lead angle setting function is inhibited by the ESC, set "Lead angle use" to "INH". The "Lead angle use" setting has priority over "Turbo mode". If "Lead angle use" is set to "INH", the lead angle setting function can be turned off even if "Turbo mode" is set to "Turbo1" or "Turbo2". The MC940,960CR shows that the lead angle setting function is OFF ("0" timing) by blinking a LED.

Roll Out Chart

This function is designed for pan cars. The roll out chart can be calculated from input values for the number of teeth of the spur gear and pinion gear, and the tire diameter, and displayed as a table.

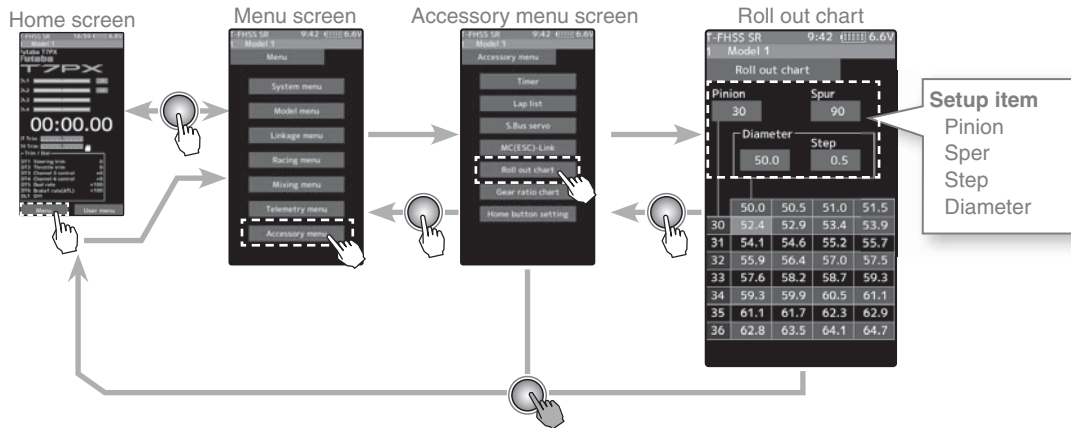

Use of Roll out chart function

1 (Setting of step of the tire diameter input)

Tap the value button of the [Step]. Value input buttons appear on the screen. Use the [+] and [-] buttons to set the step of input numerical value of tire diameter amount.

- The step amount can be set in the range of 0.1 mm to 1.0 mm.

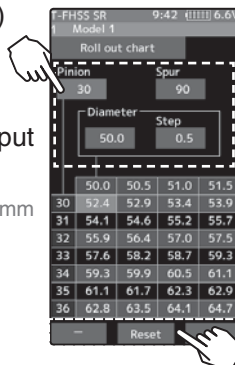

Adjustment buttons

- Adjust with the [+] and [-] buttons.
- Return to the initial value by tapping the [reset] buttons.

2 (Setting of number of teeth of spur gear)

Tap the value button of the [Super]. Value input buttons appear on the screen. Use the [+] and [-] buttons to set the spur gear. The roll out is then calculated, and the list is updated.

3 (Setting of number of teeth of pinion gear)

Tap the value button of the [Pinion]. Value input buttons appear on the screen. Use the [+] and [-] buttons to set the pinion gear. The roll out is then calculated, and the list is updated.

3 (Setting of tire diameter)

Tap the value button of the [Diameter]. Value input buttons appear on the screen. Use the [+] and [-] buttons to set the tire diameter. The roll out is then calculated, and the list is updated.

4 When finished, return to the Accessory menu screen by pressing the HOME button.

Gear Retio Chart

The Gear Retio Chart can be calculated from input values for the number of teeth of the spur gear and pinion gear, and secondary gear ratio, and displayed as a table.

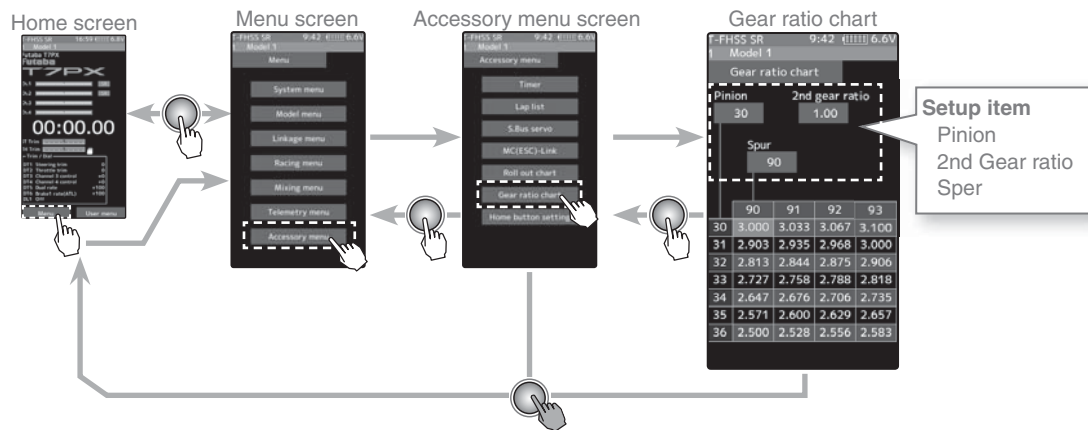

Use of Roll out chart function

1 (Setting of number of teeth of spur gear)

Tap the value button of the [Super]. Value input buttons appear on the screen. Use the [+] and [-] buttons to set the spur gear. The roll out is then calculated, and the list is updated.

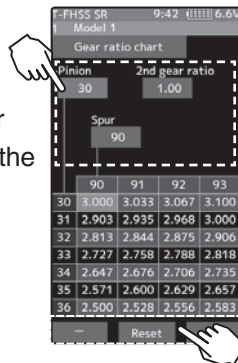

Adjustment buttons

- Adjust with the [+] and [-] buttons.
- Return to the initial value by tapping the [reset] buttons.

2 (Setting of number of teeth of pinion gear)

Tap the value button of the [Pinion]. Value input buttons appear on the screen. Use the [+] and [-] buttons to set the pinion gear. The roll out is then calculated, and the list is updated.

2 (Setting of number of secondary gear ratio)

Tap the value button of the [2nd gear ratio]. Value input buttons appear on the screen. Use the [+] and [-] buttons to set the 2nd gear ratio. The roll out is then calculated, and the list is updated.

3 When finished, return to the Accessory menu screen by pressing the HOME button.

Home Button Setting

You can select the screen to display when you push the Home button on the Home screen, menu or user menu. You can not change the screen to display by push and holding the Home button from the menu screen or each function screen.

- Push-----Display menu screen or custom menu screen.
- Long press-----Trim lock or display the function screen of your choice.

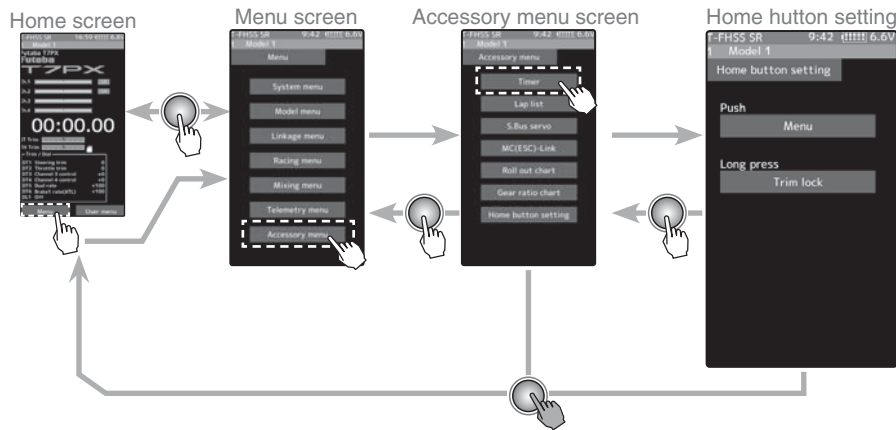

How to set the home button

1 (Setting for push)
Tap "Push" [Menu] or [User menu] to select "Menu" / "User menu".

2 (Setting for long press)
Tap "long press".
The function list appears on the home button setting menu screen. Tap and select the function you want to use. To cancel, tap [Close].

- Since there are multiple pages, tap the [Previous/Next] mark and move the page.

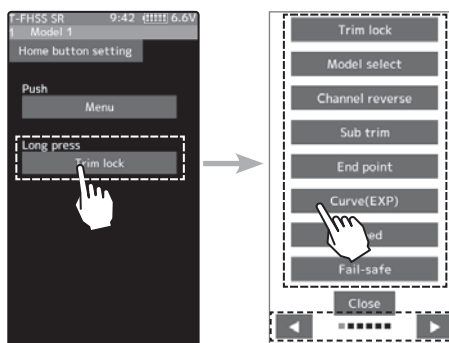

3 When finished, return to the Accessory menu screen by pressing the HOME button.

Telemetry System

With the telemetry system, the running status can be displayed at the transmitter and also recorded as a data log by installing various sensor units to the chassis

(The T-FHSS SR, S-FHSS and FASST systems do not have a telemetry function.)

-The sensor data can be checked at the transmitter by connecting the telemetry sensor sold separately to the S.BUS2 connector of the R334SBS receiver.

-To log this information, a start/stop switch is set by switch setting (page 69).

The log data recorded on a microSD card can be converted to CSV format by the telemetry log converter released at our home page. When copying or moving the log file, always select both .FLI and .FLD files.

-The figure is an example of connection of a telemetry sensor. The data of up to the following 3 types of sensor and the receiver power supply voltage can be transmitted by using the 3-way extension cord or double extension cord sold separately.

The receiver power supply can also be connected to the S.BUS2 connector or channel 1 to 4 connector. A receiver power supply voltage sensor is unnecessary.

Connection diagram

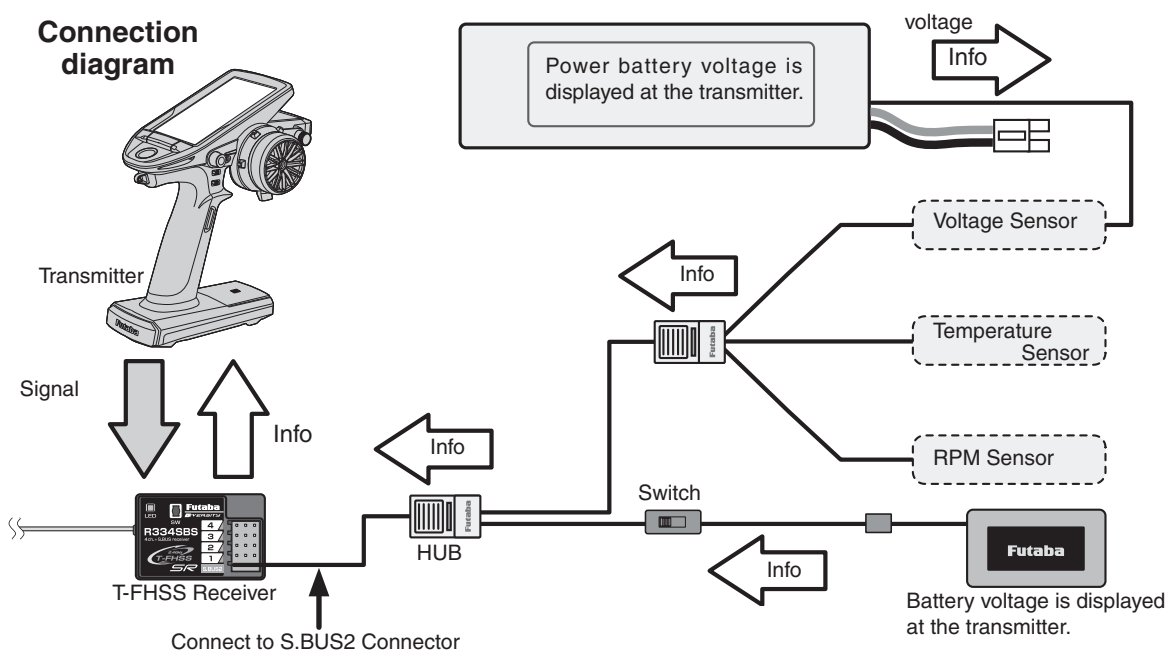

-Usable sensor options(As of May 2017)

*Temperature sensor (SBS-01T) Perfect for engine head, etc.

*Temperature sensor (SBS-01TE) Used by attaching to a motor, etc.

*RPM Sensor (SBS-01RM) Measures speed over the 0 to 999,900rpm range.

*Voltage Sensor (SBS-01V) Measures external power supply voltages up to 100V.

*Current sensor (SBS-01C) Measures external power supply voltages up to 70V, capacity and consumption capacity.

*GPS sensor (SBS-01/02G) Detect the GPS and measure the position and speed of the car body.

*Compatibility with non-Futaba sensors (Castle TL0). (Refer to the sensor instruction manual for more information.)

Telemetry

It is necessary to turn on the telemetry on the receiver setting screen to use the telemetry function. (page 52) This screen displays and sets the various information from the receiver. An alarm and vibration can be generated depending on the information. The alarm and the vibration are set by each information screen. For example, a drop in the voltage of the receiver battery housed in the model car can be reported by an alarm. The telemetry data received last is memorized. Therefore, even if the receiver power is turned off, information display, audio guide, and alarms remain until the transmitter power is turned off. The speech function can be turned on and off with the specified switch. See the switch select function (page 69).

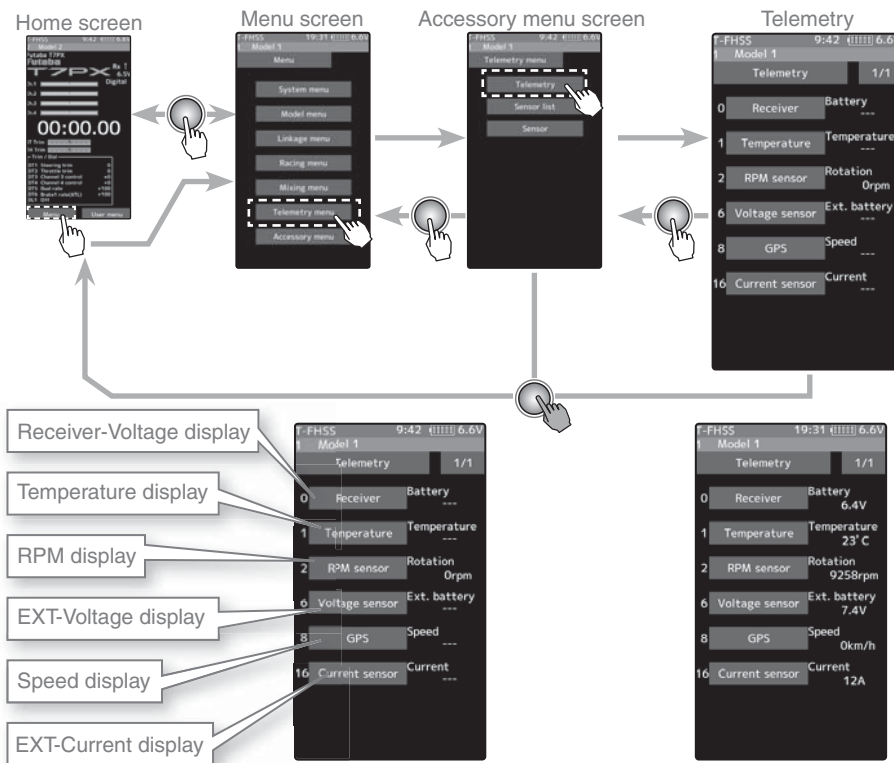

Using Telemetry function

(Preparation)

The sensor used is connected with the receiver referring to the connection diagram of page 152.

- 1** (Function ON/OFF)
Tap telemetry (ON) or (OFF) to select ON / OFF.
"OFF" :Telemetry function OFF
"ON" :Telemetry function ON

- 2** When finished, return to the Linkage menu screen by pressing the HOME button.

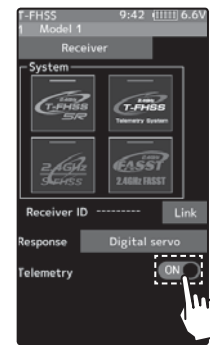

Telemetry function ON

Telemetry :Receiver Battery Voltage

This function displays and sets the receiver power supply battery. The sensor sold separately does not have to be installed. The transmitter initial state voltage is also displayed. For a description of alarm setting when the voltage drops, see the description of the procedure on this page.

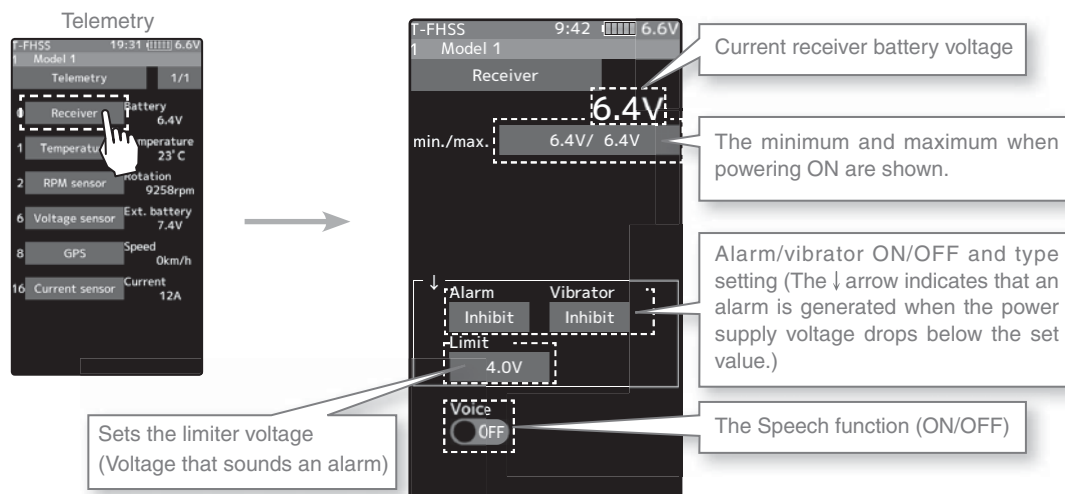

Alarm and Vibrator function setup

1 (Limit adjustment)

Tap the [Limit]. Value input buttons appear on the screen.
Use the [+] or [-] button to adjust the limit voltage.

Adjustment buttons

- Adjust with the [+] and [-] buttons.
- Return to the initial value by tapping the [reset] buttons.

2 (Alarm function setup)

Tap the [Alarm] type and select [Inhibit], [Buzzer] or [Voice].

"Inhibit" :No audible alarm
"Buzzer" :Audible alarm
"Voice" :Voice alarm

Setting

- Tap alarm type.
Inhibit/ Buzzer/ Voice

3 (Vibrator function setup)

Tap the [Vibrator] type and select [Inhibit], [Type 1], [Type 2], or [Type 3].

"Inhibit" :No active vibration
"Type1" :Continuous vibration
"Type2" :Intermittent vibration for a long time
"Type3" :Intermittent vibration for a short time

Setting

- Tap Vibrator type.
Inhibit/ Type 1/ Type 2/ Type 3

4 (Speech function setup)

Tap the "Voice" (ON) or (OFF) to select ON / OFF.

"OFF" :No voice guide
"ON" :Information loaded by voice

Setting

- Tap (ON) / (OFF).

*The voice guide loading interval is set by sensor menu.

5 When finished, return to the Telemetry screen by pressing the HOME button.

Telemetry :The Drive Battery Voltage

With an external power supply, one voltage of the batteries (drive battery, servo power supply battery, etc.) mounted separately in the chassis can be displayed at the transmitter. The receiver S.BUS2 connector is used to connect the SBS-01V sensor and the battery.

* A drive battery sensor must be installed in the model car. Install and connect the sensor in accordance with the sensor instruction manual.

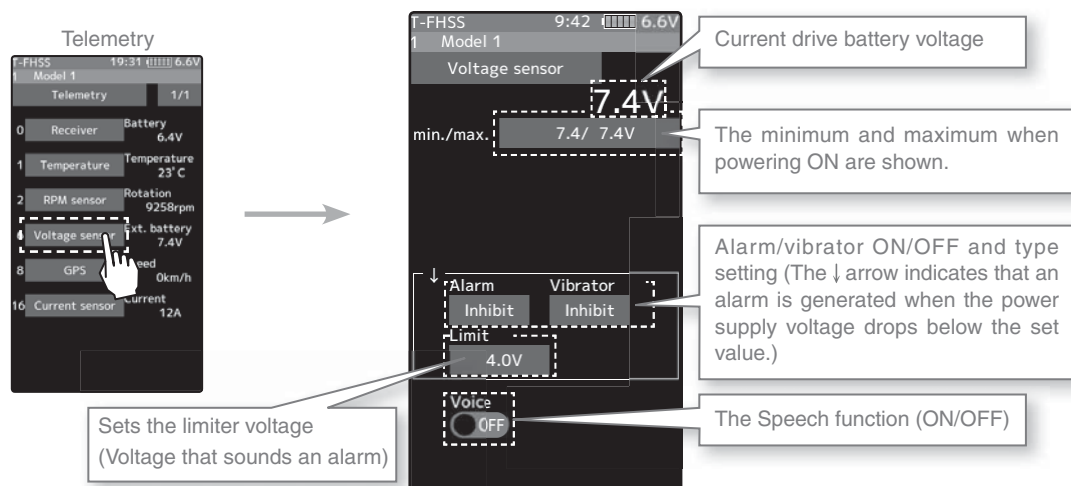

Alarm and Vibrator function setup

1 (Limit adjustment)

Tap the [Limit]. Value input buttons appear on the screen.
Use the [+] or [-] button to adjust the limit voltage.

Adjustment buttons

- Adjust with the [+] and [-] buttons.
- Return to the initial value by tapping the [reset] buttons.

2 (Alarm function setup)

Tap the [Alarm] type and select [Inhibit], [Buzzer] or [Voice].

"Inhibit" :No audible alarm
"Buzzer" :Audible alarm
"Voice" :Voice alarm

Setting

- Tap alarm type.
Inhibit/ Buzzer/ Voice

3 (Vibrator function setup)

Tap the [Vibrator] type and select [Inhibit], [Type 1], [Type 2], or [Type 3].

"Inhibit" :No active vibration
"Type1" :Continuous vibration
"Type2" :Intermittent vibration for a long time
"Type3" :Intermittent vibration for a short time

Setting

- Tap Vibrator type.
Inhibit/ Type 1/ Type 2/ Type 3

4 (Speech function setup)

Tap the "Voice" (ON) or (OFF) to select ON / OFF.

"OFF" :No voice guide
"ON" :Information loaded by voice

Setting

- Tap (ON) / (OFF).

*The voice guide loading interval is set by sensor menu.

5 When finished, return to the Telemetry screen by pressing the HOME button.

Telemetry :RPM

Speed information from an SBS-01RM (telemetry rotation sensor) sold separately is displayed and set at this screen. The speed of the engine, motor, etc. of the chassis while running can be viewed at the transmitter. When the speed becomes higher (lower) than the set speed, it can be announced by an alarm and vibration.

* A RPM sensor must be installed in the model car. Install and connect the sensor in accordance with the sensor instruction manual.

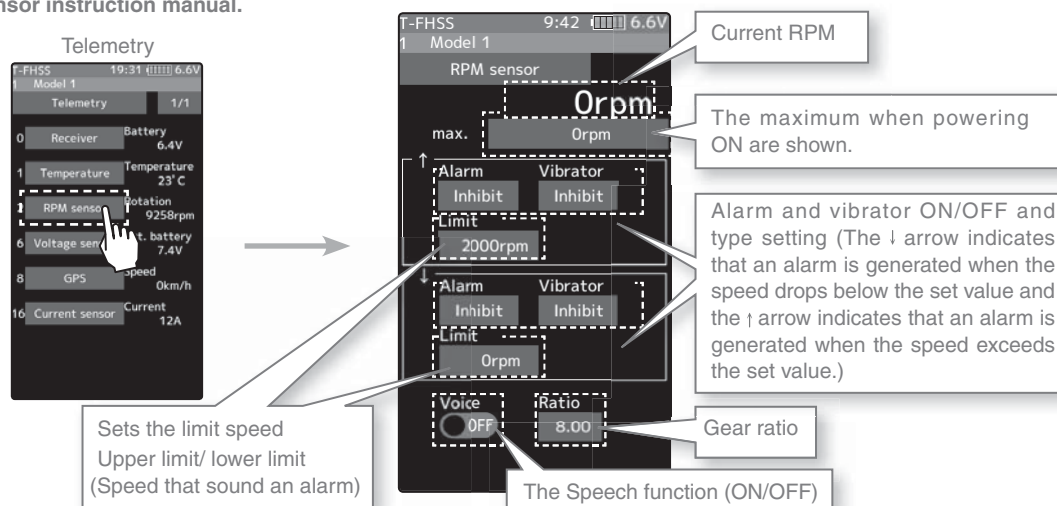

Alarm and Vibrator function setup

1 (Gear ratio adjustment)

Tap the [Gear ratio]. Value input buttons appear on the screen.

Use the [+] or [-] button to adjust the Gear ratio.

Adjustment buttons

- Adjust with the [+] and [-] buttons.
- Return to the initial value by tapping the [reset] buttons.

2 (Limit adjustment)

Tap the "↑" [Limit] or "↓" [Limit]. Value input buttons appear on the screen.

Use the [+] or [-] button to adjust the limit voltage.

3 (Alarm and vibrator function setup)

Tap the "↑" / "↓" [Alarm] type and select [Inhibit], [Buzzer] or [Voice].

"Inhibit":No audible alarm/ "Buzzer":Audible alarm/ "Voice":Voice alarm

Tap the "↑" / "↓" [Vibrator] type and select [Inhibit], [Type 1], [Type 2], or [Type 3].

"Inhibit" :No active vibration

"Type1" :Continuous vibration

"Type2" :Intermittent vibration for a long time

"Type3" :Intermittent vibration for a short time

4 (Speech function setup)

Tap the "Voice" (ON) or (OFF) to select ON / OFF.

"OFF" :No voice guide

"ON" :Information loaded by voice

*The voice guide loading interval is set by sensor menu.

5 When finished, return to the Telemetry screen by pressing the HOME button.

Telemetry :Temperature

This screen displays and sets the temperature information from an SBS-01T (telemetry temperature sensor) sold separately. The temperature of the engine, motor, amp, etc. of the chassis while running can be viewed at the transmitter. When the temperature becomes higher (lower) than the set value, it can be announced by an alarm and vibration.

* A temperature sensor must be installed in the model car. Install and connect the sensor in accordance with the sensor instruction manual.

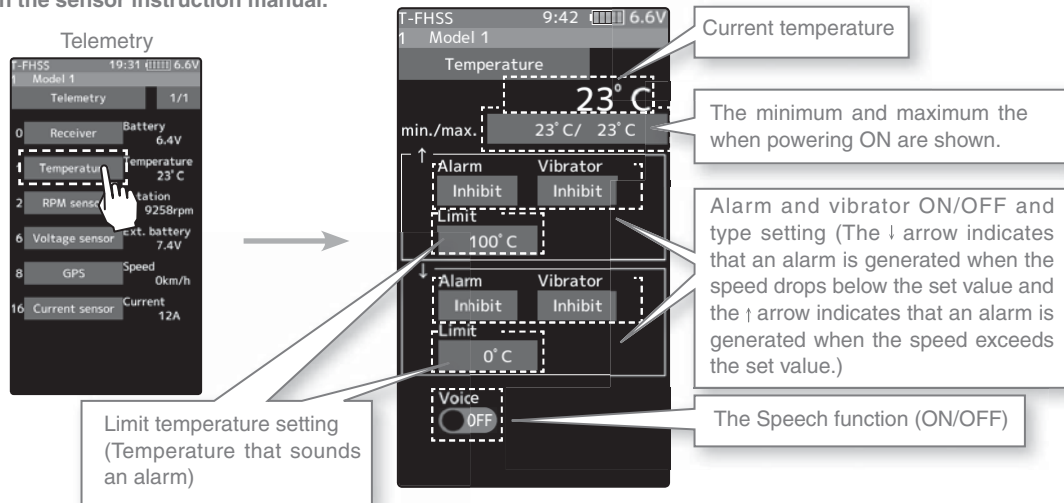

Alarm and Vibrator function setup

- 1** (Limit adjustment)

Tap the "↑" [Limit] or "↓" [Limit]. Value input buttons appear on the screen.

Use the [+] or [-] button to adjust the limit voltage.
- 2** (Alarm and vibrator function setup)

Tap the "↑" / "↓" [Alarm] type and select [Inhibit], [Buzzer] or [Voice].

"Inhibit":No audible alarm/ "Buzzer":Audible alarm/ "Voice":Voice alarm

Tap the "↑" / "↓" [Vibrator] type and select [Inhibit], [Type 1], [Type 2], or [Type 3].

"Inhibit" :No active vibration
 "Type1" :Continuous vibration
 "Type2" :Intermittent vibration for a long time
 "Type3" :Intermittent vibration for a short time
- 3** (Speech function setup)

Tap the "Voice" (ON) or (OFF) to select ON / OFF.

"OFF":No voice guide
 "ON" :Information loaded by voice

Adjustment buttons

- Adjust with the [+] and [-] buttons.
- Return to the initial value by tapping the [reset] buttons.

Setting

- Tap alarm type.
Inhibit/ Buzzer/ Voice

Setting

- Tap Vibrator type.
Inhibit/ Type 1/ Type 2/ Type 3

Setting

- Tap (ON) / (OFF).

*The voice guide loading interval is set by sensor menu.

- 4** When finished, return to the Telemetry screen by pressing the HOME button.

Telemetry :The Drive Battery Electric Current

When the SBS-01C (electric current sensor) sold separately is mounted on the vehicle, the electric current, voltage and consumption capacity of the power battery, etc., can be displayed.

* A drive battery electric current sensor must be installed in the model car. Install and connect the sensor in accordance with the sensor instruction manual.

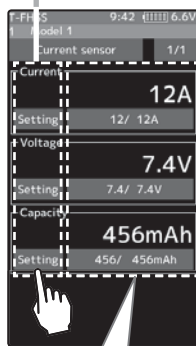
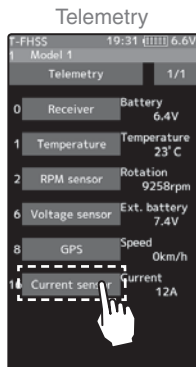

Function

-Upper side:
Current current / voltage / consumption capacity display.

-Lower:
This is a display of the minimum value / maximum value of the measured current / voltage / consumption capacity after turning on the transmitter power.

* Tap the min / max display button to restart the measurement.

Current Settings:

- Current drive battery electric current: 12A
- min./max.: 12/ 12A
- Alarm Limit: 100A
- Vibrator Limit: 0A
- Reset consumption capacity: 456mAh
- The Speech function (ON/OFF): OFF

Voltage Settings:

- Current drive battery voltage: 7.4V
- min./max.: 7.4/ 7.4V
- Alarm Limit: 50.0V
- Vibrator Limit: 10.0V
- Reset consumption capacity: 456mAh
- The Speech function (ON/OFF): OFF

Capacity Settings:

- Current drive battery capacity: 456mAh
- min./max.: 456/ 456mAh
- Alarm Limit: 4000mAh
- Vibrator Limit: 0mAh
- Reset consumption capacity: 456mAh
- The Speech function (ON/OFF): OFF

Alarm and Vibrator function setup

- 1 (Limit adjustment)
Tap the "↑" [Limit] or "↓" [Limit]. Value input buttons appear on the screen.

Use the [+] or [-] button to adjust the limit voltage.

- 2 (Alarm and vibrator function setup)
Tap the "↑" / "↓" [Alarm] type and select [Inhibit], [Buzzer] or [Voice].

"Inhibit":No audible alarm/ "Buzzer":Audible alarm/ "Voice":Voice alarm

Tap the "↑" / "↓" [Vibrator] type and select [Inhibit], [Type 1], [Type 2], or [Type 3].

"Inhibit" :No active vibration

"Type1" :Continuous vibration

"Type2" :Intermittent vibration for a long time

"Type3" :Intermittent vibration for a short time

- 3 (Speech function setup)

Tap the "Voice" (ON) or (OFF) to select ON / OFF.

"OFF" :No voice guide

"ON" :Information loaded by voice

- 4 When finished, return to the Telemetry screen by pressing the HOME button.

Adjustment buttons

- Adjust with the [+] and [-] buttons.
- Return to the initial value by tapping the [reset] buttons.

Setting

- Tap alarm type.
Inhibit/ Buzzer/ Voice

Setting

- Tap Vibrator type.
Inhibit/ Type 1/ Type 2/ Type 3

Setting

- Tap (ON) / (OFF).

*The voice guide loading interval is set by sensor menu.

Reset consumption capacity display

Unless the reset button of SBS-01C is pressed, the consumption capacity measured by SBS-01C is maintained and displayed as "integrated capacity" on the screen. If you wish to measure the consumption capacity for one run, it is possible to reset the consumption capacity display on the transmitter by the next operation. However, the record of the integrated capacity of the SBS-01C main body cannot be reset by the function which resets the transmitter display.

- 1 (Reset operation)

Tap the [Reset], the consumption capacity display is reset to 0. The consumption capacity from the time of reset is displayed until you reset it again. If you reset the consumption capacity by pressing the reset button of SBS-01C, the consumption capacity display on the transmitter is also reset.

- 2 When finished, return to the Telemetry screen by pressing the HOME button.

The reset operation on the transmitter resets the integrated capacity display on the T7PX. It does not reset the integrated capacity on the SBS-01C. The consumption capacity measurement range of SBS-01C is 32767mAh maximum. When this value is exceeded, the consumption capacity display on the transmitter is also reset automatically. Depending on the timing, reset may occur during measurement. Therefore, make sure to reset the integrated capacity on the SBS-01C before the integrated capacity display reaches 32767mAh.

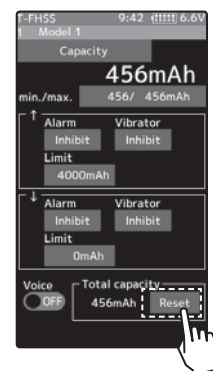

Function

Telemetry :GPS

When SBS-01G/02G (GPS sensor) sold separately is mounted on the car body, you can receive radio waves from GPS satellites and display information on the position and speed of the car.

* A GPS sensor must be installed in the model car. Install and connect the sensor in accordance with the sensor instruction manual.

* When powered up, the SBS-01/02G begins to acquire GPS satellite data. This process can take several minutes. Please do not move the model during this process. During acquisition, the LED on the SBS-01/02G will blink green; after the satellite's signals have been acquired, the LED will become solid green, and the GPS signal strength display on the transmitter will show three bars.

Moving the model before the satellites are fully acquired will cause a delay in acquiring the satellite signal.

* Since GPS satellites are basically used, accurate distances and speeds may not be displayed depending on the surrounding environment or the conditions of the course.

Telemetry

1-FHSS 19:31 6.6V
Model 1
Telemetry 1/1

0 Receiver Battery 6.4V
1 Temperature Temperature 23°C
2 RPM sensor Rotation 9258rpm
6 Voltage sensor Ext. battery 7.4V
8 GPS Speed 0km/h
14 Current sensor Current 12A

Distance

1-FHSS 9:42 6.6V
Model 1
Distance
14m
max. 14m
Alarm Inhibit Inhibit
Limit 1000m
Alarm Inhibit Inhibit
Limit 0m
Voice OFF Preset reference

Speed

1-FHSS 9:42 6.6V
Model 1
Speed
0km/h
max. 0km/h
Alarm Inhibit Inhibit
Limit 200km/h
Alarm Inhibit Inhibit
Limit 0km/h
Voice OFF Preset reference

Function

This indicates the receiving accuracy from a GPS Satellite.

The position of the present model is displayed.

-Upper side:
Current distance and speed display.

-Lower:
This is a display of the maximum value of the measured distance and speed after turning on the transmitter power.

* Tap the max display button to restart the measurement.

Current distance

The maximum when powering ON are shown.

* Tap the max display button to restart the measurement.

Alarm and vibrator ON/OFF and type setting (The arrow indicates that an alarm is generated when the minimum distance below the set value and the arrow indicates that an alarm is generated when the distance exceeds the set value.)

Tap the [Preset reference]. Sets the current car position as the starting point.

The Speech function (ON/OFF)

Current speed

The maximum when powering ON are shown.

* Tap the max display button to restart the measurement.

Alarm and vibrator ON/OFF and type setting (The arrow indicates that an alarm is generated when the minimum speed below the set value and the arrow indicates that an alarm is generated when the speed exceeds the set value.)

Tap the [Preset reference]. Sets the current car position as the starting point.

The Speech function (ON/OFF)

Alarm and Vibrator function setup

- 1** (Limit adjustment)
Tap the "↑" [Limit] or "↓" [Limit]. Value input buttons appear on the screen.

Use the [+] or [-] button to adjust the limit voltage.

- 2** (Alarm and vibrator function setup)
Tap the "↑" / "↓" [Alarm] type and select [Inhibit], [Buzzer] or [Voice].

"Inhibit":No audible alarm/ "Buzzer":Audible alarm/ "Voice":Voice alarm

Tap the "↑" / "↓" [Vibrator] type and select [Inhibit], [Type 1], [Type 2], or [Type 3].

"Inhibit" :No active vibration

"Type1" :Continuous vibration

"Type2" :Intermittent vibration for a long time

"Type3" :Intermittent vibration for a short time

- 3** (Speech function setup)

Tap the "Voice" (ON) or (OFF) to select ON / OFF.

"OFF" :No voice guide

"ON" :Information loaded by voice

- 4** When finished, return to the Telemetry screen by pressing the HOME button.

Adjustment buttons

- Adjust with the [+] and [-] buttons.
- Return to the initial value by tapping the [reset] buttons.

Setting

- Tap alarm type.
Inhibit/ Buzzer/ Voice

Setting

- Tap Vibrator type.
Inhibit/ Type 1/ Type 2/ Type 3

Setting

- Tap (ON) / (OFF).

*The voice guide loading interval is set by sensor menu.

How to set the reference position

It takes a while for GPS to be measured after turning on the power. Please wait until the LED of the GPS sensor turns on green without moving the car body. If the distance display does not stabilize even after the green LED lights up, or if you set a new reference value for the place where the car body moved, reset the reference position.

- 1** (reset operation)
Since either the distance / speed screen can be used, tap [Reference position setting]. The distance is reset. After that, the distance from the point where resetting is done is displayed until tapping [Reference position setting] again.

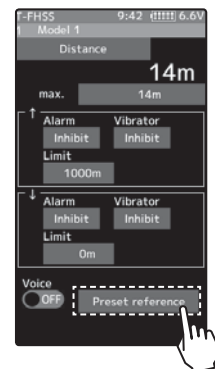

Function

Sensor List

This menu registers the telemetry sensors used with the transmitter. When only one of a certain type of sensor is used, this setting is unnecessary and the sensor can be used by simply connecting it to the S.BUS2 port of the transmitter.

When using 2 or more of the same kind of sensor, they must be registered here.

What is a slot?

Servos are classified by CH, but sensors are classified in units called "slot". There are slots from No. 1 to No. 31. Using a sensor which uses two or more slots, the required number of slots is automatically assigned by setting up a start slot. When 2 or more of the same kind of sensor are used, the sensors themselves must allocate unused slots and memorize that slot.

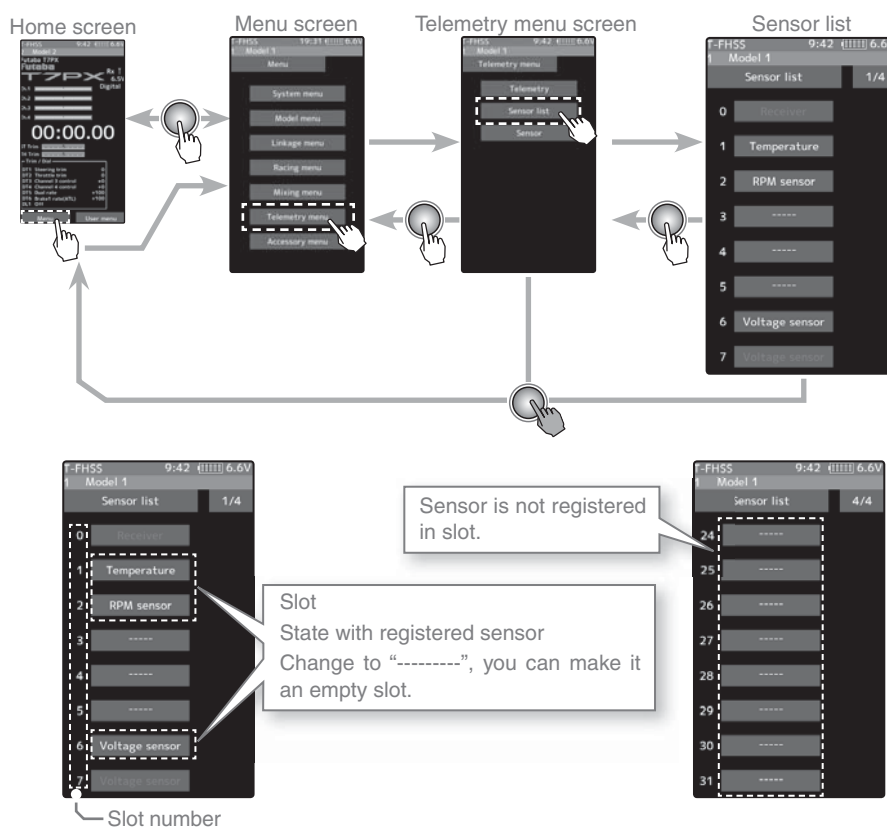

Function

About the slots that can be used.

As shown in the table below, the current sensor requires three consecutive slots, and the GPS sensor requires 8 consecutive slots. The GPS sensor (SBS - 01 / 02G) has a starting slot of 8.16.24.

sensor	The required number of slots	The number which can be used as a start slot
TEMP(SBS-01T)	1 slot	1~31
RPM(SBS01RM)	1 slot	1~31
Voltage(SBS-01V)	2 slot	1, 2, 3, 4, 5, 6, 8, 9, 10, 11, 12, 13, 14, 16, 17, 18, 19, 20, 21, 22, 24, 25, 26, 27, 28, 29, 30
Current(SBS-01C)	2 slot	1, 2, 3, 4, 5, 6, 8, 9, 10, 11, 12, 13, 16, 17, 18, 19, 20, 21, 24, 25, 26, 27, 28, 29
GPS(SBS-01/02G)	8 slot	8, 16, 24

How to change start slot and set empty slot

1 (Start slot selection)

Tap [Slot], the list of sensors that can be registered in the start slot will be displayed. Sensors that can not be changed are not displayed.

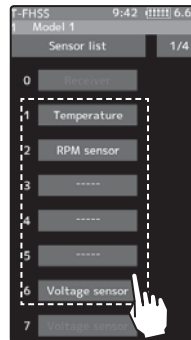

Start slot selection

- Tap the slot

2 (Sensor selection)

From the sensor list, tap the sensor you want to register in the start slot. To set as an empty slot, tap [-----]. This completes the change.

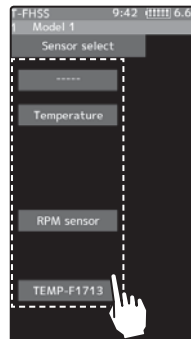

Sensor selection

- Tap the sensor

3 When finished, return to the Sensor list screen by pressing the HOME button.

Sensor

With this menu, you can display the telemetry meter on the home screen.

Also, you can register a telemetry sensor in the transmitter. When using each sensor of the initial setting one by one, setting here is unnecessary. You can use it by connecting the purchased sensor to the S.BUS 2 port of the receiver. If you use multiple sensors of the same type, such as temperature sensor for both battery and motor, you need to register that sensor in the transmitter.

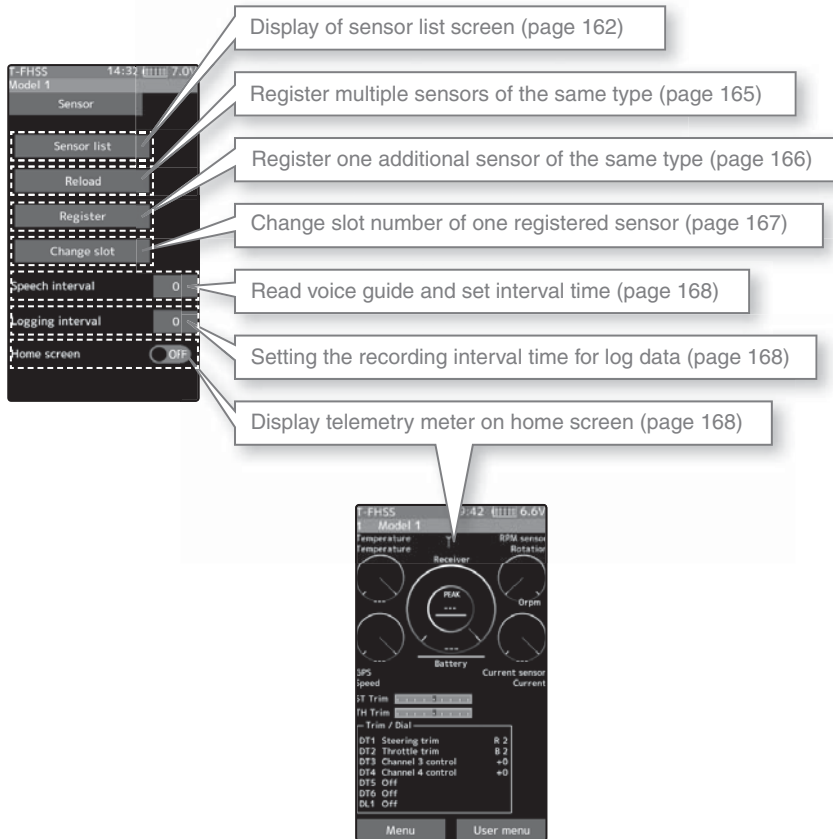
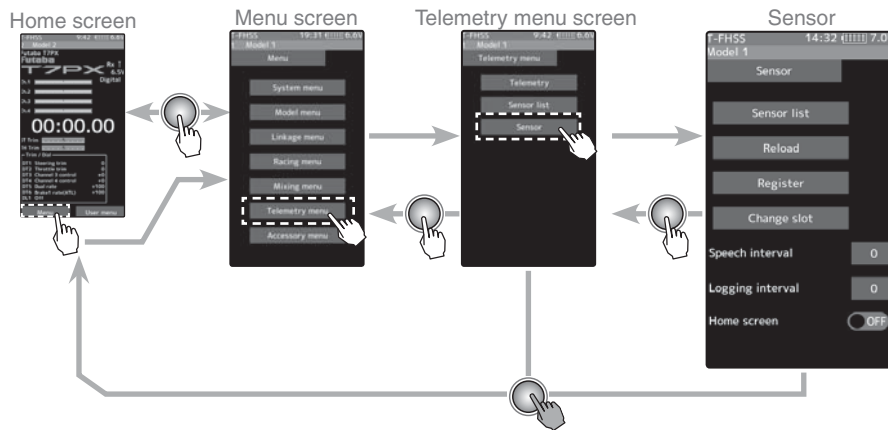

Function

Sensor Reload

When using multiple sensors of the same type the sensors must be registered in the transmitter. Connect all the sensors to be used to the T7PX as shown in the figure at the right and register them by the following procedure. The ID of each sensor is registered in the transmitter.

To load the sensor, connect all sensors to be used to the T7PX communication port as shown below. Power supply is unnecessary. Also, to clear all sensor registration, execute this [Reload] function without connecting sensor. The registration is cleared and all the slots in the sensor list are unregistered.

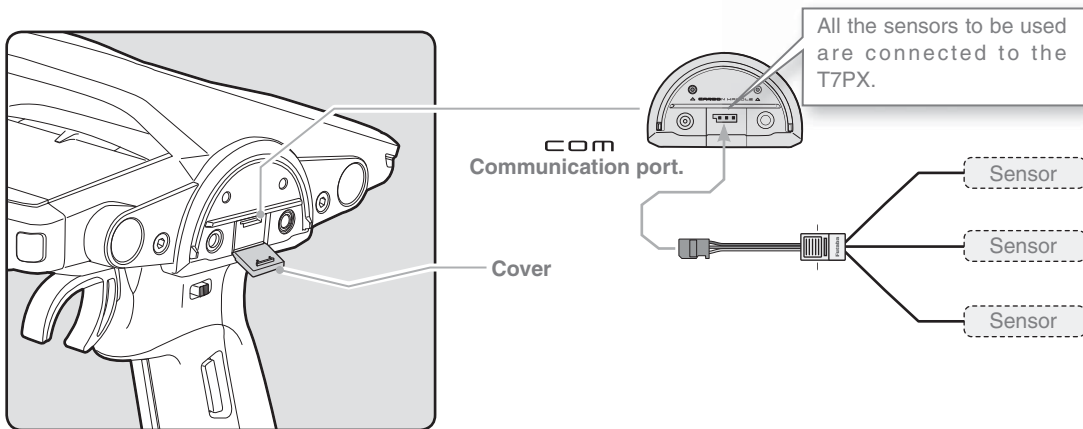

How to change start slot and set empty slot

1 (Start slot selection)

Tap the [Reload], The confirmation screen will be displayed. To execute, tap [Yes] to hear an electronic sound and finish setting. To cancel, select [No] and touch it. If "Success" appears on the screen, reload is complete.

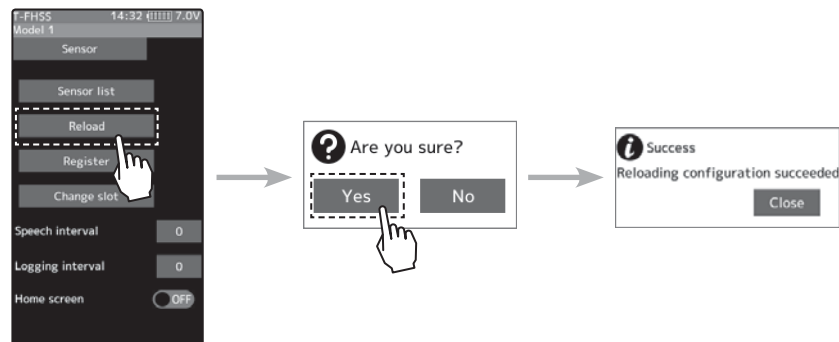

2 When finished, return to the Telemetry screen by pressing the HOME button.

Sensor Register

This function registers additional sensors. Connect the sensor as shown in the figure and register as follows. The sensor ID is registered in the transmitter.

This function is set when adding one telemetry sensor of the same type.

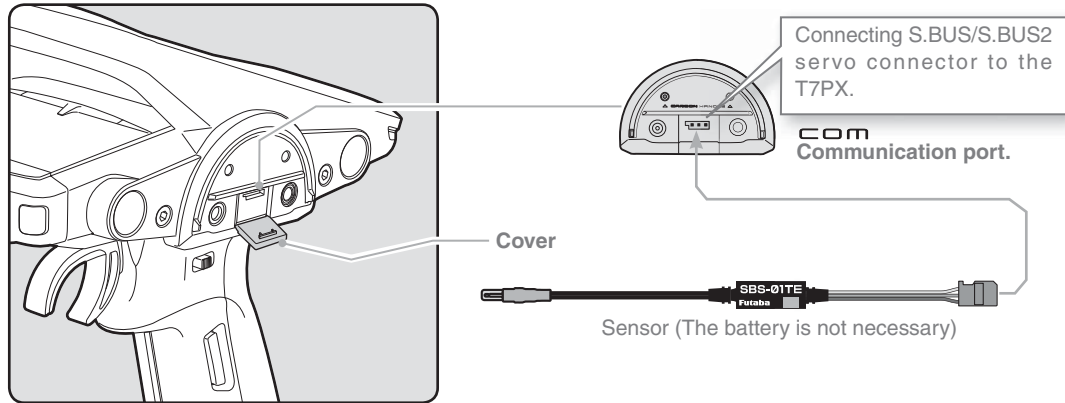

How to change start slot and set empty slot

1 (Start slot selection)

Tap the [Register], The confirmation screen will be displayed. To execute, tap [Yes] to hear an electronic sound and finish setting. To cancel, select [No] and touch it. If "Success" appears on the screen, registration is complete. If registering a sensor that has already been registered is attempted, the message "Failed; The same sensor has been registered" will be displayed. If the message "Failed; The connected sensor is not ready." is displayed, check the sensor connection. If it is securely connected, the sensor or the transmitter may be faulty.

Function

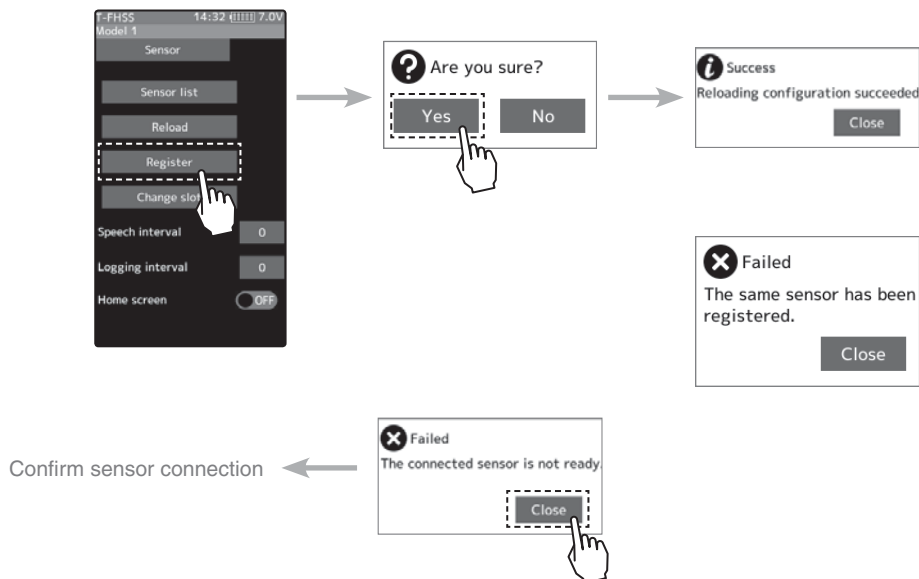

2 When finished, return to the Telemetry screen by pressing the HOME button.

Change Slot

This procedure changes the slot number of one registered sensor. Connect the sensor as shown in the figure (page 166), and change slot number.

This function is set when using multiple telemetry sensors of the same type.

Sensor slot change

1 (Change)

Tap the [Change slot]. The sensor details screen is displayed. Tap the [Read]. The confirmation screen will be displayed. To execute, tap [Yes] to hear an electronic sound and finish reading. To cancel, select [No] and touch it. If "Reading succeeded" appears and the current sensor information is displayed.

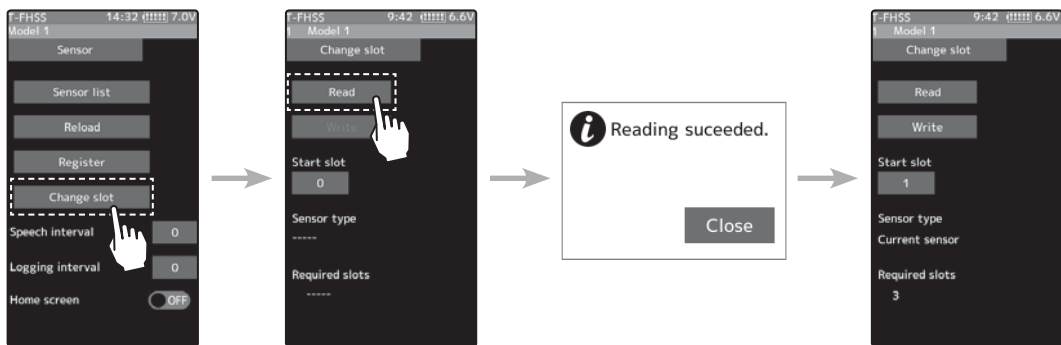

2 (Number setting)

Tap the value button of the [Start slot #]. Value input buttons appear on the screen. Use the [+] and [-] buttons to set the start slot number.



Setting button

Setting with the [+] and [-] buttons.

3 Tap the [Write]. When "Writing succeeded" message is displayed, the number change is completed.

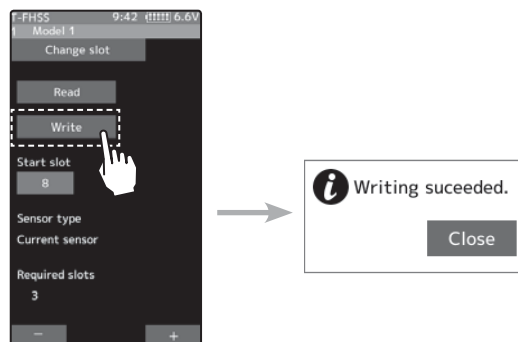

4 When finished, return to the Sensor screen by pressing the HOME button.

Speech guide interval and log data interval setting

You can set the interval at which to read the voice guide of telemetry information and the interval at which log data is recorded.

Setting interval

- 1 (Setting of speech interval)
Tap the value button of the [Speech interval]. Value input buttons appear on the screen. Use the [+] and [-] buttons to adjust the speech interval amount.

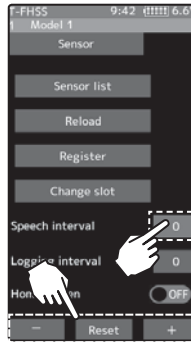

- Adjustment buttons**
- Adjust with the [+] and [-] buttons.
 - Return to the initial value by tapping the [reset] buttons.

Speech interval
0~ 30 sec
Initial value: 0

- 2 (Setting of logging interval)
Tap the value button of the [Logging interval]. Value input buttons appear on the screen. Use the [+] and [-] buttons to adjust the logging interval amount.

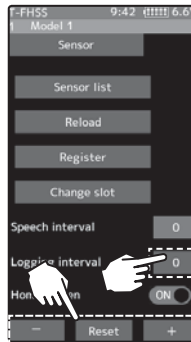

- Adjustment buttons**
- Adjust with the [+] and [-] buttons.
 - Return to the initial value by tapping the [reset] buttons.

Logging interval
0~ 30 sec
Initial value: 0

- 3 When finished, return to the Telemetry screen by pressing the HOME button.

Telemetry meter display on home screen

Telemetry information on the home screen, graphic meter can be displayed.

Display of telemetry meter

- 1 (Function ON/OFF)
Tap "Home screen" (ON) or (OFF) to select ON / OFF.

"OFF" : Telemetry meter not displayed
"ON" : Telemetry meter display

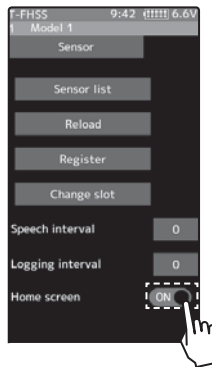

- 3 When finished, return to the Telemetry screen by pressing the HOME button.

Telemetry meter display settings

Five telemetry meters displayed on the home screen are displayed. You can select the sensor to display and set the range of display data. It can be set for each meter.

Home screen

Tap meter to set display range etc.

Tap to select sensor to display

Display the screen to select the sensor to be displayed.

When the sensor to be displayed can measure multiple data, select which data to display.

Set the upper limit / lower limit displayed on the meter.

Tap the value button of the [Max.] and [Min]. Value input buttons appear on the screen. Use the [+] and [-] buttons to adjust the upper limit and lower limit amount.

Function

Sensor

Model Select

Forty model data (model data for 40 R/C cars) can be saved in the T7PX transmitter and used when the relevant model data is called. However, models copied in the microSD card can not be used by directly calling from the card. Please copy it to the T7PX main unit when using it.

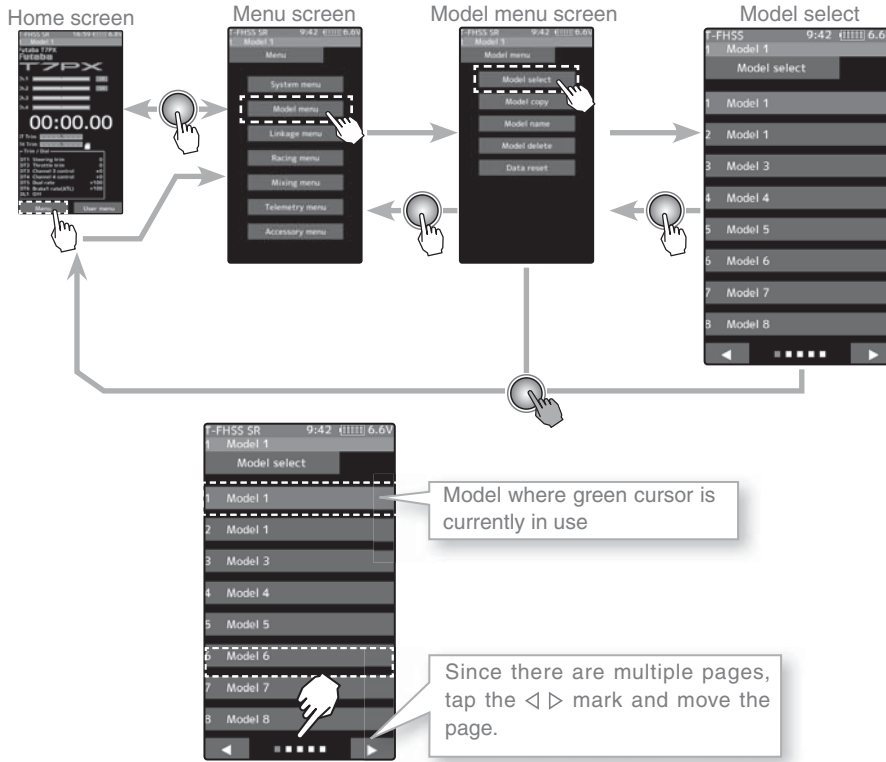

Using the model selection function

- 1 (Model memory selection)**
You can choose from 8 models on 1 page and 40 models on 5 pages. Tap the <|> mark at the bottom of screen to move the page.

Model #.
M1~M40
Model selection
- Tap the [Model name]

- 2 (Model selection execution)**
Tap the [Model name] to use, a confirmation screen will be displayed saying "Are you sure?" To execute, tap [Yes], a beep sounds and the change is completed and the home screen is displayed. To cancel, tap [No] and tap.
- If the model name of the home screen is changed, model selection is completed.

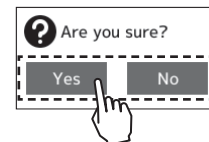
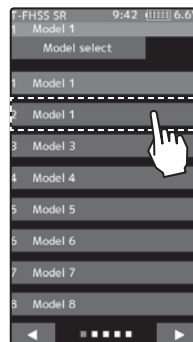

- 3** When finished, return to the Model menu screen by pressing the HOME button.

Model Copy

The contents of the model memory can be copied to another model memory. The contents can also be saved or stored on a microSD card for copying to another T7PX.

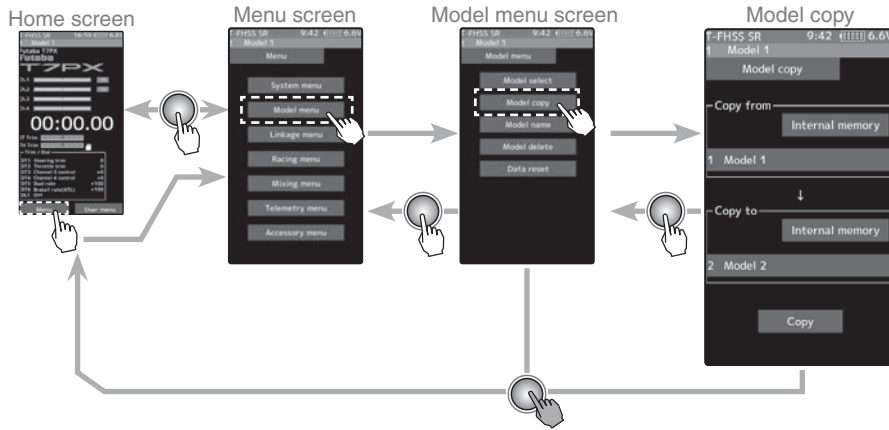

Model copying

1 (Copy source model selection)

You can choose from 8 models on 1 page and 40 models on 5 pages. Tap the <|> mark at the bottom of screen to move the page.

Copy source

Tap to select from the list

2 (Model selection execution)

Tap the "Copy from" [model name], select the model list so it will tap. The source model is selected and the model list is closed. The list is the same design as the model select and the way of moving the page is the same. If a microSD card is installed in the T7PX main unit, a button for selecting either the model inside the T7PX main unit or the model inside the microSD card will be displayed, so tap to select it. To cancel, press the Home button to return to the model copy screen.

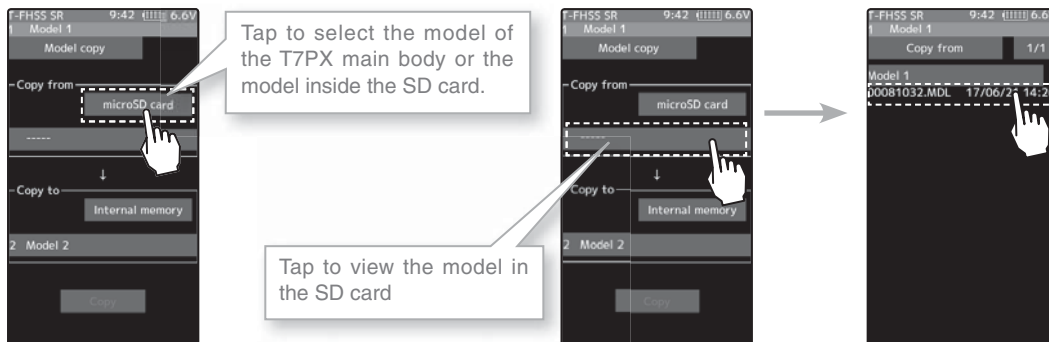
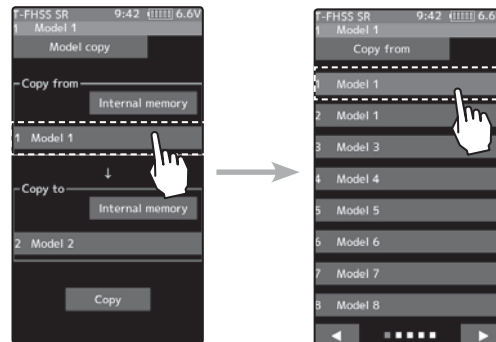

Tap to select the model of the T7PX main body or the model inside the SD card.

Tap to view the model in the SD card

Function

3 (Copy destination model selection)

Tap the "Copy to" [model name], select the model list so it will tap. The source model is selected and the model list is closed.

- The model currently in use cannot be selected.
- Since the copy destination cannot be overwritten when it is in a microSD card, a models list is not displayed and the model is saved directly to the microSD card.

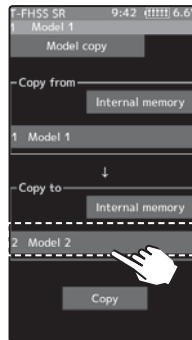

Copy destination

Tap to select from the list

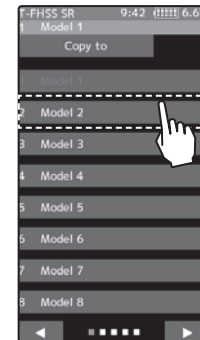

4 (Copy execution)

Tap the [Copy], The confirmation message "Are you sure" appears. To execute copy, tap [Yes] and to cancel copy, select [No]. When the copy destination model name becomes the same name as the copy source, copying is complete.

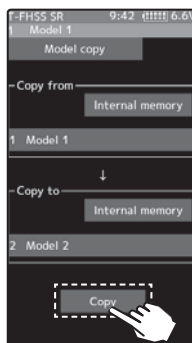

Copy execution

Tap the [Copy]

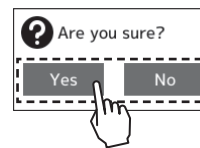

5 When finished, return to the Model menu screen by pressing the HOME button.

microSD card storage destination

When a microSD card is installed in the T7PX, a folder called "Futaba" is created, and folders called "LOG" and "MODEL" are created in it. The "MODEL" folder contains the model data.

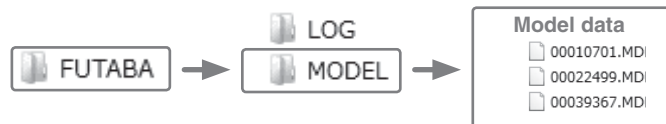
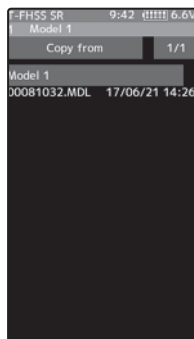

When the T7PX model data is copied, and the copy source data is selected from the model data stored in the microSD, a model list like that shown at the left is displayed.

Model Name

This function allows you to assign a ten character name to each model memory.

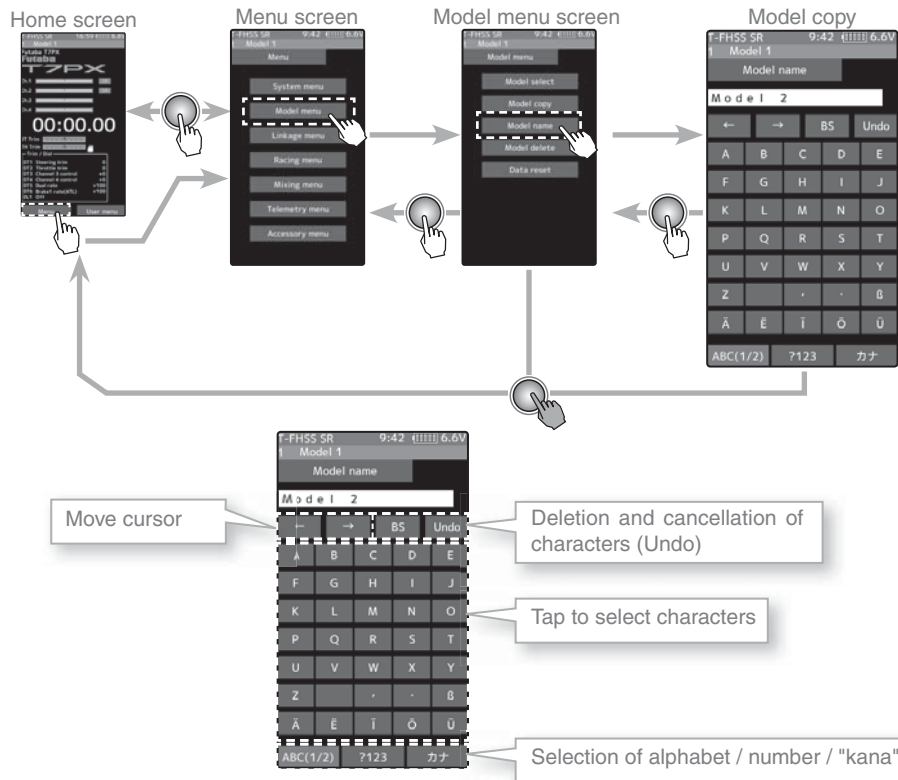

Setting the model name and user name

- 1** (Moving the cursor to the character you want to change.)
 In the model name, tap [←], [→] to move the cursor and select the character of the model name you want to set or change. A vertical line cursor is displayed before the selected character.
- 2** (Selection of characters to use)
 Select the character to use from the character list. When you decide the character to use, tap it. The character is determined and the character string of the model name moves to the right. If you tap [BS], the left character of the vertical line cursor will be deleted. To redo, tap [Undo].
- 3** When finished, return to the Model menu screen by pressing the HOME button.

Name cursor movement

Use the [←] / [→] tap to move the cursor. Also, when you decide a character, when the cursor position of the model name moves to the right, the cursor position of the model name moves to the right

Select / determine character

Select a character, tap it to determine the character

Function

Model Delete (Model saved on microSD card)

This function deletes model data saved on the microSD card.

Model deletion is displayed on the menu only when microSD card is set in the T7PX card slot.

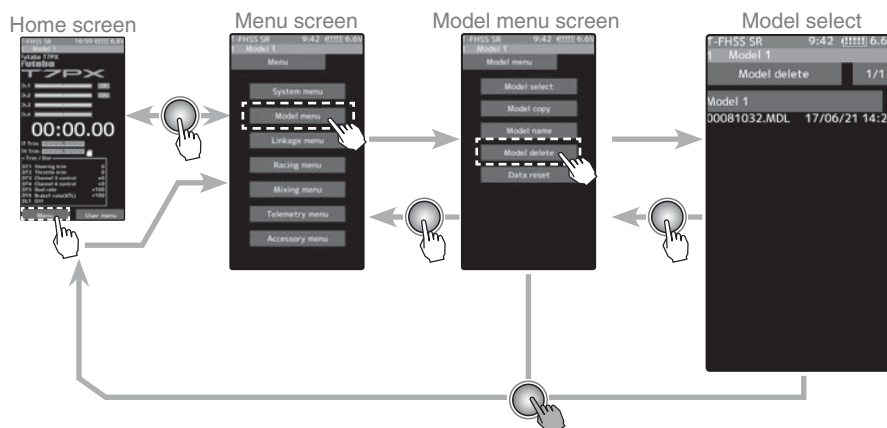

How to delete model data in microSD card

1 (selection of model data)

If the number of models that does not fit on one page is memorized, tap [1/2] in the upper right corner to move the page.

If there are 2 pages, it will be displayed as [1/2] / [2/2], if there are 5 pages, it will be displayed as [1/5] to [5/5].

2 (execution of model deletion)

Tap the model you want to delete. A confirmation message "Are you sure?" appears. Tap [Yes] to execute the deletion, or [No] to cancel.

"Deleting succeeded" is displayed and deletion is completed.

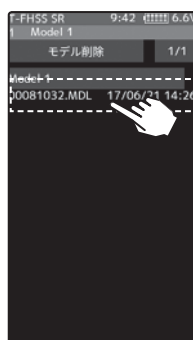

Delete execution

Tap the [model data]

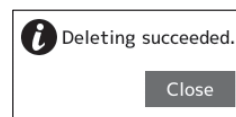
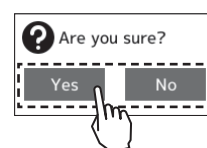

3 When finished, return to the Model menu screen by pressing the HOME button.

Data Reset

This function resets the contents of the currently called model memory.

The reset method can be selected from among the 4 types described below. These resets do not initialize the adjuster function and system function.

-Model data

Initializes only the function setting data. The direct menu function is not initialized.

-User menu

Initializes the user menu function. Other settings are not initialized.

-Telemetry

Telemetry related setup data is initialized.

-All data

Initializes the direct selection function, receiver setting function and the setting data of each function.

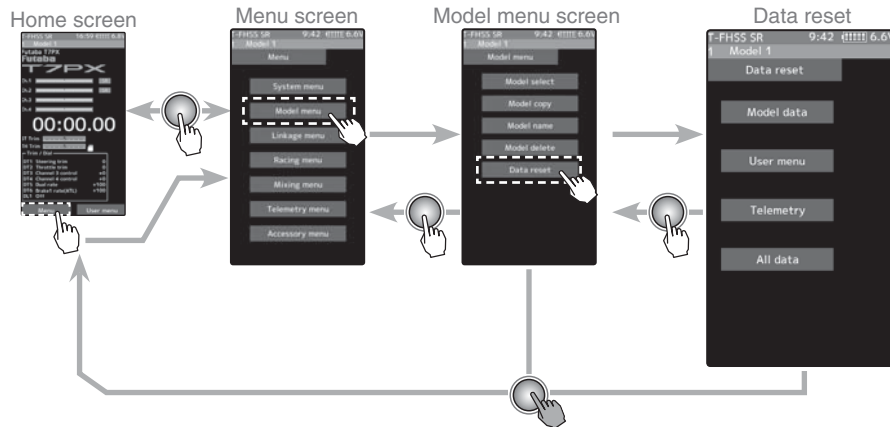

Data Reset

1 (Execution of reset)

Select the type you want to reset and tap. A confirmation message will be displayed as "Are you sure?" If you want to execute, tap [No] to cancel with [Yes]. Reset is now complete.

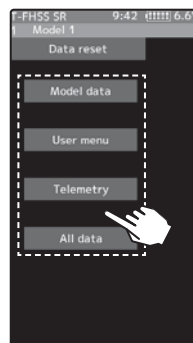

Reset execution

Tap the [reset type]

Reset type

- Model data
- User menu
- Telemetry
- All data

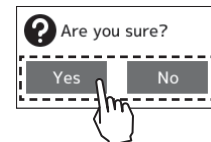

2 When finished, return to the Model menu screen by pressing the HOME button.

Display

Backlight brightness, dimming time etc. setting and tap panel correction menu.
There is also a tap panel sensitivity adjustment.

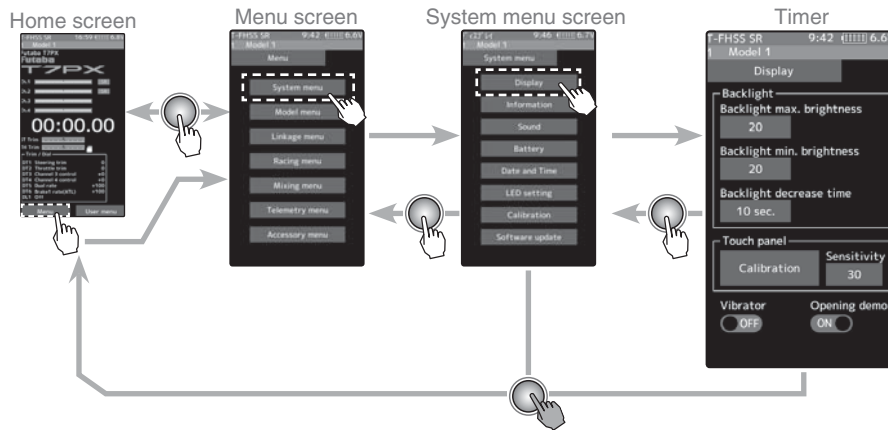

Display setup

1 (Backlight decrease brightness adjustment)
Tap the value button of the [Backlight max, brightness] or [Backlight min, brightness]. Value input buttons appear on the screen and use the [+] and [-] buttons to adjust the backlight decrease brightness amount.

2 (Backlight decrease time)
You can set a time period to decrease the LCD backlight. This function counts the period that the touch panel has been not operated. This time can be set by one second steps. You can also turn off the backlight decrease if you like.
Tap the value button of the [Backlight decrease time]. Value input buttons appear on the screen and use the [+] and [-] buttons to adjust the backlight decrease time amount.

3 (Tap panel correction)
Tap [Calibration]. It will be a black screen with a white + mark at the center of the screen. Tap on the intersection of that + mark in order, using 5 stylus pens etc of our company.
To cancel, press the Home button to return to the display setting screen.

Adjust button

Adjust with the [+] and [-] buttons.
- Return to the initial value by tapping the [reset] buttons.

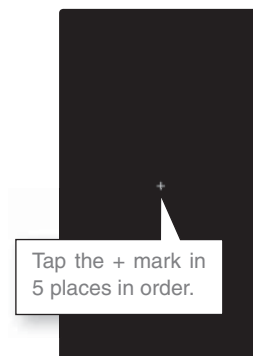

-
- 4** (Tap panel sensitivity adjustment)
You can adjust the sensitivity of the tap panel.
Tap the value button of the [Sensitivity]. Value input buttons appear on the screen and use the [+] and [-] buttons to adjust the sensitivity of the touch panel.

Adjust button

Adjust with the [+] and [-] buttons.
- Return to the initial value by tapping the [reset] buttons.

Sensitivity

10-100

Initial value : 30

-
- 5** (Touch Panel Vibrate ON / OFF)
The vibrate can be operated by the operation of the touch panel. Tap on the "Vibrator" (ON) or (OFF) and select ON / OFF.

"OFF" :Function OFF

"ON" :Function ON

Setting

- Tap (ON) / (OFF).

-
- 6** (Setting of start / end screen)
Set whether or not to display the Futaba T7PX logo mark on startup and exit screens. If it is set to OFF, it disappears.
Tap on the "Opening demo" (ON) or (OFF) and select ON / OFF.

"OFF" :Function OFF

"ON" :Function ON

Setting

- Tap (ON) / (OFF).

-
- 7** When finished, return to the System menu screen by pressing the HOME button.

Information

With this system information, you can select user name setting, display language, use unit of telemetry information. Also displays the software version.

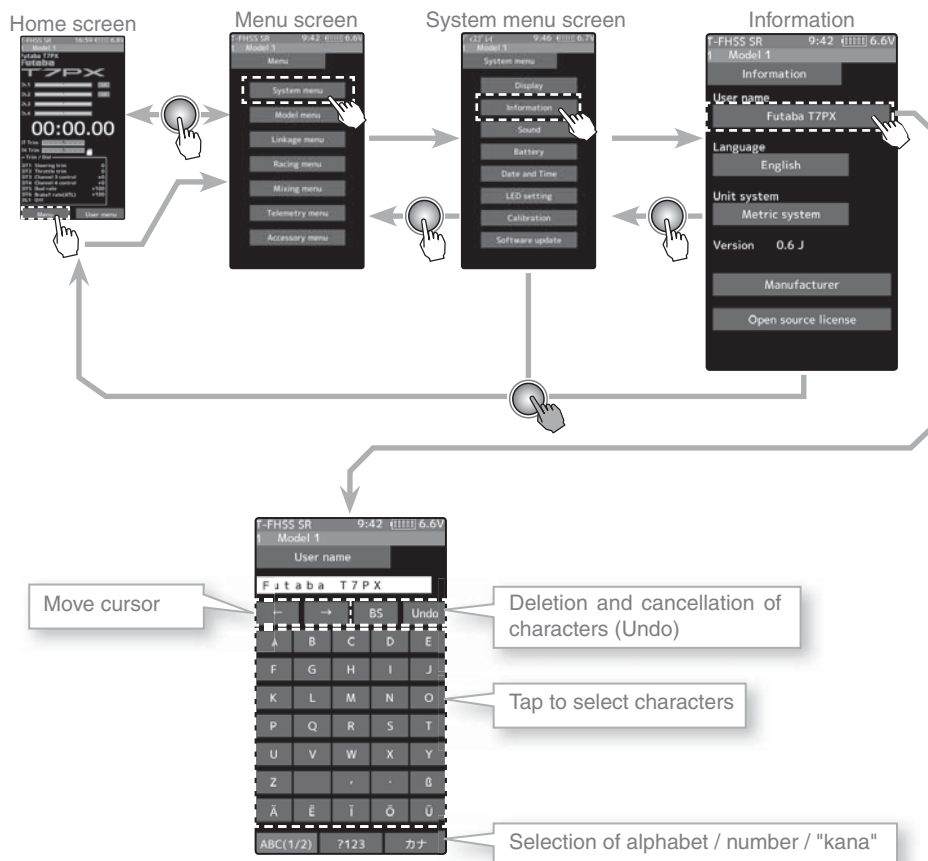

Setting the user name

- 1 (Moving the cursor to the character you want to change.)
In the model name, tap [←], [→] to move the cursor and select the character of the model name you want to set or change. A vertical line cursor is displayed before the selected character.
- 2 (Selection of characters to use)
Select the character to use from the character list. When you decide the character to use, tap it. The character is determined and the character string of the model name moves to the right. If you tap [BS], the left character of the vertical line cursor will be deleted. To redo, tap [Undo].
3 When finished, return to the Model menu screen by pressing the HOME button.
- 3 When finished, return to the System menu screen by pressing the HOME button.

Name cursor movement

Use the [←] / [→] tap to move the cursor. Also, when you decide a character, when the cursor position of the model name moves to the right, the cursor position of the right moves to the right

Select / determine character

Select a character, tap it to determine the character

Language setting

1 (Language select)

Tap [Language], a list of languages will be displayed on the screen. If you tap the language you want to use from the list, the language display will be changed and you will be taken to the home screen.

-The available languages will be added in the future.

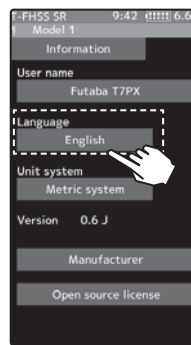

Language select

Tap to select from the list

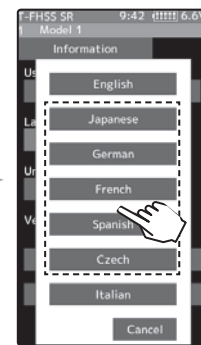

Units system setting

1 (Units system setting)

Tap [Unit System] and set it to either the metric method or the yard / pound method.

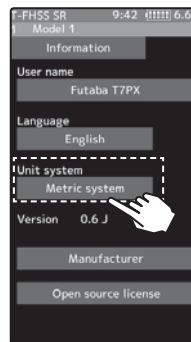

Setting

- Tap Units system
Metric system
Yard-pound system

Display of manufacturer information and open source license

1 (Units system setting)

Tap [Open source license], displays the manufacturer information and the license information of the font used in the system.

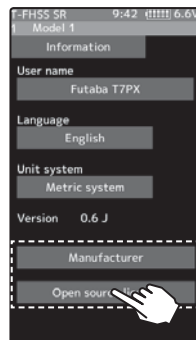

Function

3 When finished, return to the System menu screen by pressing the HOME button.

Sound

This function can set the volume of "Key Operation", "Warning" and "Telemetry speech info".

-The volume of the click when edit key, jog, and trim are operated can be adjusted.

-The volume of the audible alarm sound can be adjusted.

-When the telemetry function is used, the volume of the voice that announces the temperature, speed, voltage, and other information at a fixed interval can be adjusted.

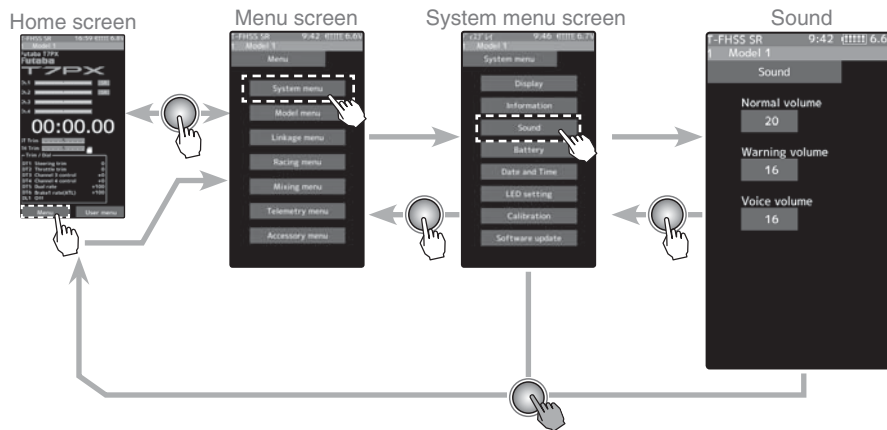

Volume adjustment

- 1** (Adjusting the key operation volume)
Tap the value button of the [Normal volume]. Value input buttons appear on the screen and use the [+] and [-] buttons to adjust the volume.
- 2** (Adjusting the warning volume)
Tap the value button of the [Warning volume]. Value input buttons appear on the screen and use the [+] and [-] buttons to adjust the volume.
- 3** (Adjusting the voice volume)
Tap the value button of the [Voice volume]. Value input buttons appear on the screen and use the [+] and [-] buttons to adjust the volume.

Adjust button

Adjust with the [+] and [-] buttons.

- Return to the initial value by tapping the [reset] buttons.

Normal volume

0~32

Initial value : 16

Warning volume

1~32

Initial value : 16

Voice volume

0~32

Initial value : 16

- 4** When finished, return to the System menu screen by pressing the HOME button.

Battery

With the T7PX, the low battery alarm setting is different, depending on the type of battery. Therefore, always set the battery type matched to the power supply to be used. When using a Futaba rechargeable type battery, always select "LiFe 2 cells" or "NiMH 5 cells". Incorrect setting will substantially shorten the time from low battery alarm to system stopping and is very dangerous.

Exceptionally, when using a battery other than this, select "Other" and set the low battery alarm voltage on your own responsibility. Futaba is not responsible for trouble caused by use of an unspecified battery.

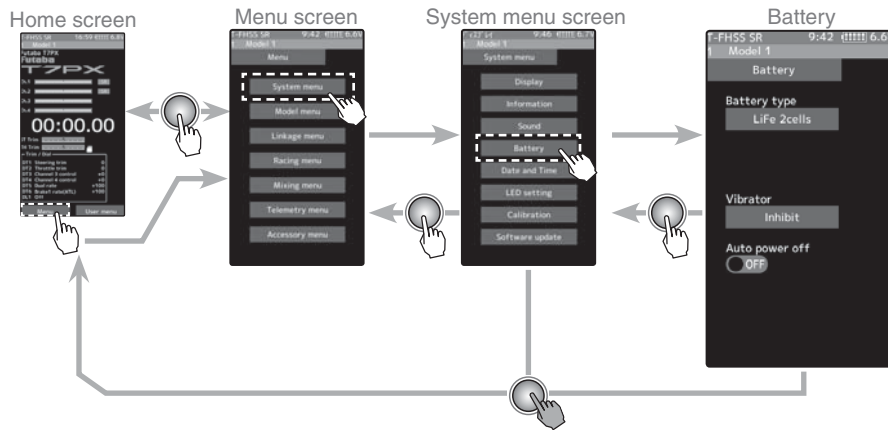

Battery setting

1 (Select battery type)

Tap [Battery type], a list of battery type will be displayed on the screen. tap the battery type you want to use from the list.

-When set to [Other], please set the alarm voltage by yourself.

Setting

- Tap list
- LiFe 2 sell
- NiMH 5 cell
- Other

2 (Select vibrator type)

Tap the [Vibrator] type and select [Inhibit], [Type 1], [Type 2], or [Type 3].

Setting

- Tap Vibrator type.
- Inhibit/ Type 1/ Type 2/ Type 3

3 (Auto power off setting)

Tap on the "Auto power off" (ON) or (OFF) and select ON / OFF.

"OFF" :Function OFF
 "ON" :Function ON

Setting

- Tap (ON) / (OFF).

4 When finished, return to the System menu screen by pressing the HOME button.

Data And Time

This function adjusts the system clock of the T7PX transmitter. Perform this setting when you purchase the set and when adjustment is necessary.

Whether the time or the total timer (accumulation timer) is displayed on the initial screen can be set. The total timer can be reset at this menu.

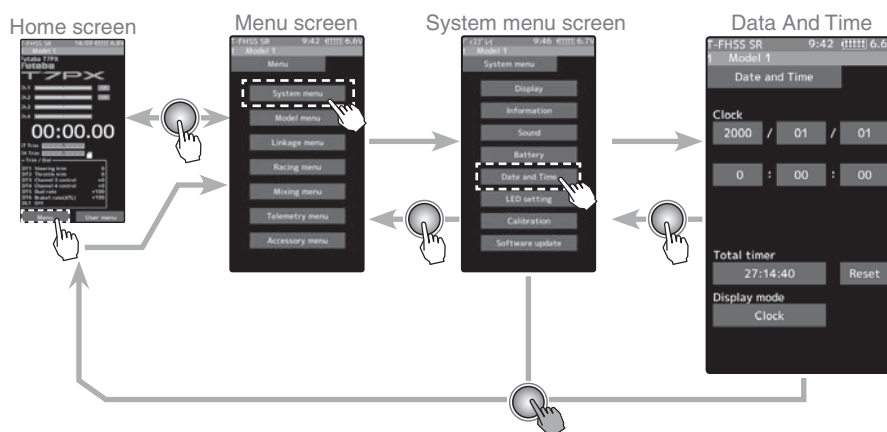

Date and time setting

- 1 (Date and time setting)
Tap the value button of the [Year], [Month], [Day], [Hour], [Minute] or [Second]. Value input buttons appear on the screen. use the [+] and [-] buttons to set the date and time amount. When the setting is changed, the [Time adjust] button will be displayed, so tap this to update the system clock.

- The date and time will be reset after a long period of time with the battery removed from the transmitter.

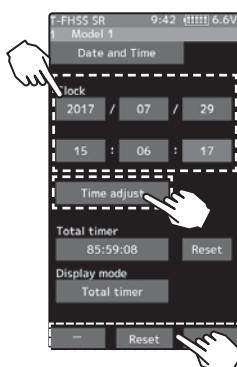

Adjust button

Adjust with the [+] and [-] buttons.
- Return to the initial value by tapping the [reset] buttons.

Timer reset

tap the [reset]

- 2 (Total tome reset)
Tap the [Reset]. The total time is reset.

- 3 (Select home screen display mode)
Tap on the "Display mode" [Clock] or [Total timer] and select Clock / Total timer.

- 4 When finished, return to the System menu screen by pressing the HOME button.

Setting

- Tap display mode.
Clock
Total time

LED Setting

You can adjust the brightness and lighting method of the pilot LED light.

The pilot LED lighting method can be selected from "always on", "off" or "interlock with backlight".

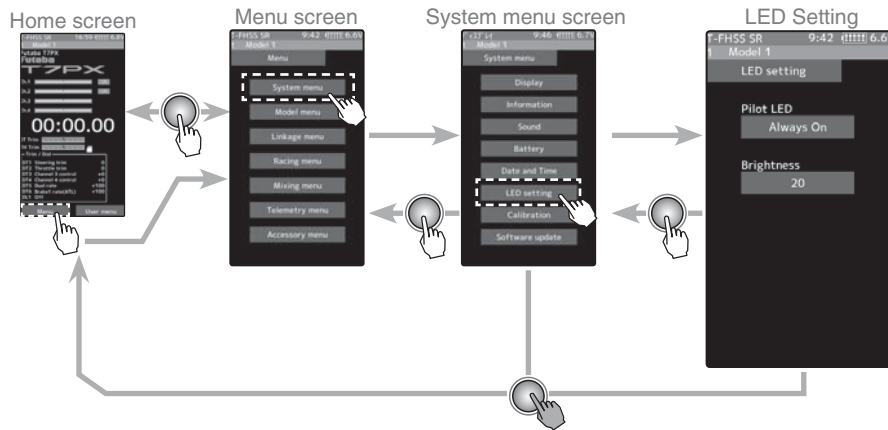

LED setting

1 (Setting pilot LED)

Tap the [Pilot LED], a list of lighting mode will be displayed on the screen. tap the lighting mode you want to use from the list.

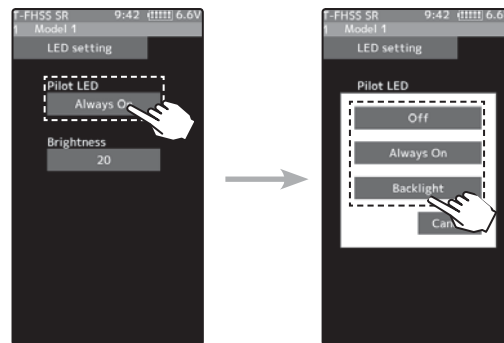

Pilot LED mode
Backlight, Always On, OFF

2 (Setting Pilot LED brightness)

Tap the value button of the [Brightness]. Value input buttons appear on the screen and use the [+] and [-] buttons to adjust the pilot LED brightness amount.

Adjust button
Adjust with the [+] and [-] buttons.
- Return to the initial value by tapping the [reset] buttons.

Brightness
0~20
Initial value : 20

3 When finished, return to the System menu screen by pressing the HOME button.

Calibration

Steering and throttle correction can be applied. Use this function when a mechanical offset has occurred for some reason.

However, if correction was applied, it may be necessary to recheck the set values of all the setup functions.

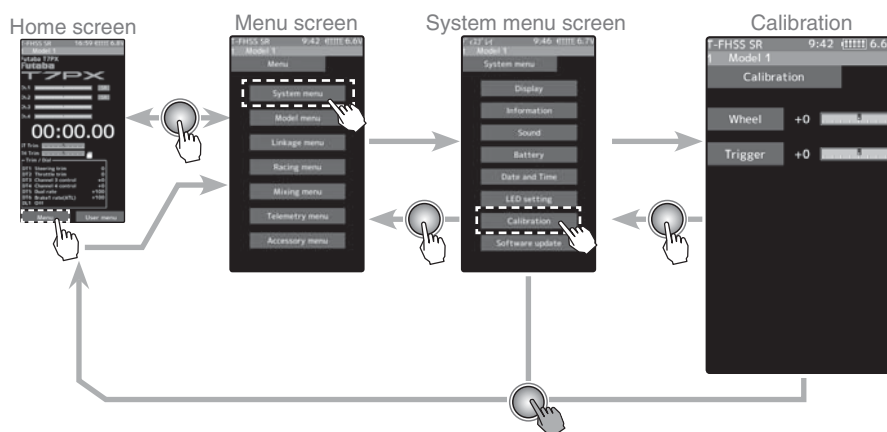

Steering adjustment

(Preparation)

Tap the [Wheel]. The neutral correction screen appears.

1 (Steering neutral adjustment)

After the wheel lightly to the left or right, tap the [Neutral] in the state in which the wheel is not touched. If neutral correction is OK, the end point correction screen appears. If not within the correction range, the end point correction screen will not appear.

2 (Steering wheel travel adjustment)

In the end point correction screen (figure at the right) state, lightly turn the wheel fully to the left and right and tap the [End point]. If end point correction is OK, the display returns to the adjuster screen. If the end point is not within the correction range, the display does not return to the adjuster screen. In this case, return to the system menu screen by pressing the HOME button. If operation cannot be ended normally even when correction is repeated, please contact the Futaba Service Center.

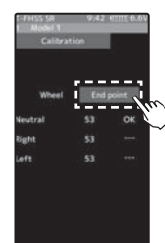
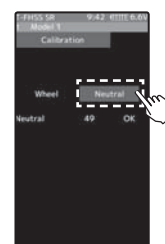

3 When finished, return to the System menu screen by pressing the HOME button.

Throttle adjustment

(Preparation)

Tap the [Trigger]. The neutral correction screen appears.

1 (Throttle neutral adjustment)

After lightly pulling the throttle trigger to the forward and brake, tap the [Neutral] in the state in which the trigger is not touched. If neutral correction is OK, the end point correction screen appears. If not within the correction range, the end point correction screen will not appear.

2 (Throttle trigger travel adjustment)

In the end point correction screen (figure at the right) state, lightly operate the trigger to the full forward and full brake side and tap the [End point]. If end point correction is OK, the display returns to the adjuster screen. If not within the correction range, the display will not return to the adjuster screen. In this case, return to the system menu by pressing the HOME button. When operation cannot be ended normally even when correction is repeated, and cannot be ended normally, contact the Futaba Service Center.

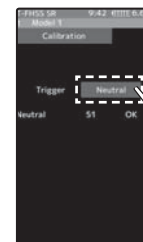

3 When finished, return to the System menu screen by pressing the HOME button.

Software update

If software update is required in the future, there are two ways of using microSD and using NFC communication. This menu is updated with NFC compatible Android device.

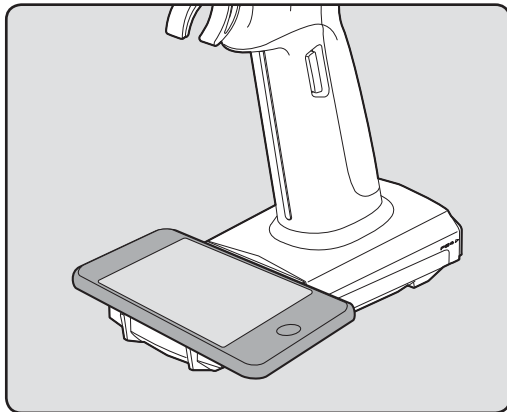
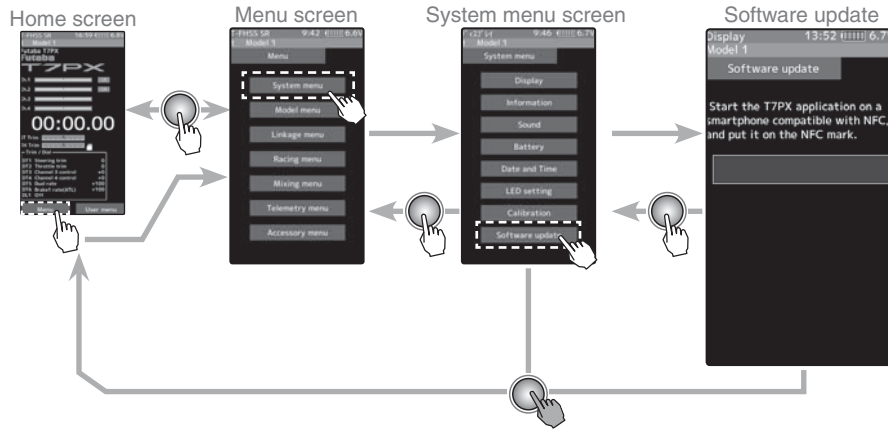

We can not guarantee that all devices can update. Depending on the model of the device, the update may not start. In that case please update with SD card.



The N-Mark is a trademark or registered trademark of NFC Forum, Inc. in the United States and in other countries.

Date and time setting

- 1 Launch the T7PX application on an Android device compatible with NFC, and place the NFC mark of the device on the NFC mark of T7PX referring to the figure above. Download of update data will start.

* If the message "The downloaded file is broken. Please try again." is displayed, communication has not been performed normally. Please redisplay T7PX and terminal screen and try again.

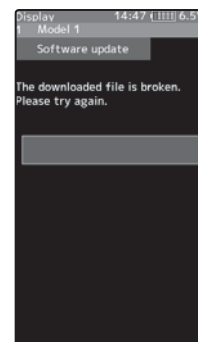
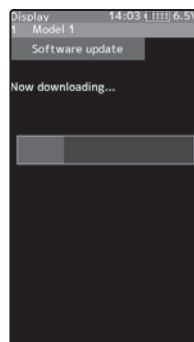

- 2 When the update is successfully completed, the T7PX will restart.

Specifications

Transmitter T7PX

*Specifications and ratings are subject to change without prior notice.

- Wheel system, 7 channels (4 channels except the S-FHSS system.)
- Transmitting frequencies 2.4GHz band /- Transmitting RF power output: 100mW EIRP
- Futaba T-FHSS SR/T-FHSS/S-FHSS/FASST-C2
- Power requirement
 - (Ni-MH battery) NT5F1800B Ni-MH battery (6V)
 - (LiFe battery) FT2F1700BV2 (6.6V)
- Current drain 350mA or less (When the T-FHSS, Vibration off, back lighting on)
- Transmitting antenna 1/2λ dipole
- 4.3 inch backlighted color TFT liquid crystal touch panel.

*When you turn on your 7PX, bright dots may appear on your screen display. Your display contains an extremely large number of TFT and is manufactured using high-precision technology. Any bright dots that may appear on your display are intrinsic of the TFT manufacturing technology.

Receiver R334SBS / : (T-FHSS SR /T-FHSS system, 4 channels)

- Receiving frequency: 2.4GHz band /- Telemetry Receiver RF power output: 10mW EIRP
- Power requirement: 3.7V~7.4V battery (Dry cell battery cannot be used.)
- System: S-FHSS SR/T-FHSS system (auto detection) /S.BUS2 system
- Size: 1.34x0.88x0.45" (33.9x22.3x11.3mm) (excluding a projection part) /- Weight :0.23oz. (7.5g)

Caution

! Be sure to use the T7PX receiver setting and the servo to be used under predetermined conditions. Under other conditions, the set will not operate, or the specified performance will not be displayed even if it operates. In addition, it may cause servo trouble. Futaba will not be responsible for damage, etc. caused by combination with the products of other companies.

System	Response / SR node	Usable servos
T-FHSS SR	SR mode channel: ON	- SR mode of Futaba SR compatible servo.
	SR mode channel: OFF	- Normal mode of Futaba SR compatible servo. - Futaba digital servo.
T-FHSS	Digital servo	- Normal mode of Futaba SR compatible servo. - Futaba digital servo.
	Analog servo	- Futaba all servo. (Normal mode of Futaba SR compatible servo.)
S-FHSS	Digital servo	- Normal mode of Futaba SR compatible servo. - Futaba digital servo.
	Analog servo	- Futaba all servo. (Normal mode of Futaba SR compatible servo.)
FASST	Digital servo	- Normal mode of Futaba SR compatible servo. - Futaba digital servo.
	Analog servo	- Futaba all servo. (Normal mode of Futaba SR compatible servo.)

Receiver's battery: Matched to the ratings of the receiver and connected servo (dry cell battery cannot be used).

In addition, the FSU Fail Safe Unit cannot be used because the system is different. Use the fail safe function of the transmitter.

Parameter by type of servo for SR mode

When setting SR mode compatible servo to SR mode with S. BUS servo menu, choose from 3 types.
The table below shows the initial setting parameter table by type.

SR mode compatible servos	SR type	Frequency	Dead band	Damper	Smoother	Stretcher	Boost	Boost
BLS371SV	Type1	2	0.11	68	INH	4.000	ACT	12
	Type2	3	0.11	68	INH	4.000	ACT	14
	Type3	4	0.11	64	INH	2.500	ACT	18
BLS471SV	Type1	2	0.11	66	INH	1.250	ACT	20
	Type2	3	0.11	58	INH	0.875	ACT	20
	Type3	4	0.11	60	INH	1.000	ACT	20
BLS571SV	Type1	2	0.11	48	INH	2.500	ACT	10
	Type2	3	0.11	40	INH	2.500	ACT	10
	Type3	4	0.11	40	INH	2.500	ACT	20
BLS671SV	Type1	2	0.11	44	INH	4.000	ACT	14
	Type2	3	0.11	48	INH	4.000	ACT	20
	Type3	4	0.11	40	INH	4.000	ACT	20
S9372SV S9373SV	Type1	2	0.11	50	ACT	1.500	ACT	10
	Type2	3	0.11	82	ACT	1.250	ACT	14
	Type3	4	0.11	86	ACT	2.000	ACT	20
O.S.SPEED T-1	Type1	2	0.11	56	INH	2.500	ACT	10
	Type2	3	0.11	48	INH	2.000	ACT	10
	Type3	4	0.11	48	INH	2.000	ACT	20
O.S.SPEED R-1	Type1	2	0.11	72	INH	3.000	ACT	12
	Type2	3	0.11	72	INH	2.500	ACT	12
	Type3	4	0.11	80	INH	2.500	ACT	16
O.S.SPEED B-1	Type1	2	0.11	88	INH	2.000	ACT	10
	Type2	3	0.11	96	INH	2.000	ACT	10
	Type3	4	0.11	96	INH	2.000	ACT	20

System Compatibility

The 7PX is a 2.4GHz T-FHSS SR and T-FHSS surface system. The transmitter can also be switched to S-FHSS and FASST. (However, the telemetry system can be used T-FHSS only.) The usable receivers are shown below.

Communications System	Usable Receivers
T-FHSS SR/T-FHSS (Default)	R334SBS
T-FHSS	R304SB/ R304SBE *R3008SB, T-FHSS Air system receivers do not operate.
S-FHSS (Change is possible)	R2104GF/ R204GF-E/ R2008SB/ R2006GS *The analog servo mode of the S - FHSS system can use up to 7 channels. When using 5 or more channels, R2008SB and R2006GS can be used.
FASST (Change is possible)	R614FS/ R614FF-E/ R604FS/ R604FS-E

Warning Displays

Low Battery Alarm

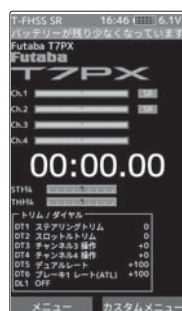

If the transmitter battery voltage drops below the usable range, an audible alarm will sound and "Low battery" will be displayed. Since the usable range of LiFe and NiMH batteries and LiFe batteries is different, the power supply used must be set by system setting.(page 181)

Audible alarm: Continuous tone.

The vibrator: Active (initial setting) page 181

Warning

When a low battery alarm is generated, cease operation immediately and retrieve the model.

If the battery goes dead while in operation, you will lose control.

Power off forgotten alarm

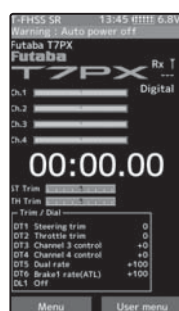

At T7PX initialization, if steering wheel, throttle trigger, push switch, HOME button, or other operation is not performed within 10 minutes, an audible alarm will sound and the message "Warning: Auto power off" will appear. If steering wheel, throttle trigger, push switch, HOME button or other operation is performed, the alarm is reset. Also turn off the power when the transmitter is not in use. If you do not want to use this alarm and the auto power off function, they can be disabled by system setting. (page 181)

Audible alarm: Continuous tone.

- If the alarm is not reset, the auto power off function will automatically turn off the power after 5 minutes.

MIX Warning

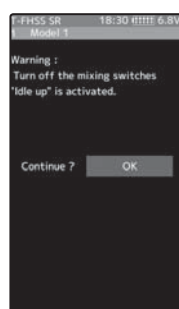

When the power switch is turned on while the idle-up, engine cut or neutral brake function switch is on, an audible alarm will sound and "Warning" will be displayed on the LCD. When that function switch is turned off, the alarm will stop.

Audible alarm: Continuous tone.

- The alarm stops even if the [OK] is tapped. However, check the function switch.

RF Error

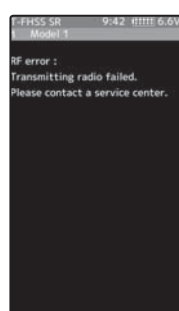

When the RF module does not operate, "RF Error" is displayed on the LCD and an audible alarm will sound. Immediately turn off the power.

Audible alarm: Continuous tone.

- To stop the alarm, turn off the power.
- Turn the power back on. If the alarm is generated again, request repair from the Futaba Service Center.

Backup Error

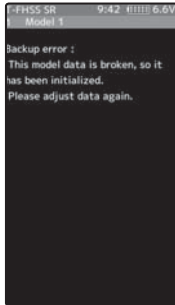

If the data in the transmitter is not transferred normally when the power is turned on, an audible alarm will sound and "Backup error" will be displayed on the LCD.

Audible alarm: Continuous tone.

- To stop the alarm, turn off the power.
- Turn the power back on. If the alarm is not generated again, there is no problem.

System Error

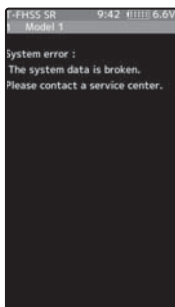

If the data is lost for an unknown reason, an audible alarm will sound and "System error" will be displayed on the LCD screen.

Audible alarm: Continuous tone.

Warning

- ❗ When a system error is generated, immediately stop using the system and request repair from the Futaba Service Center.
If you continue to use the system, the transmitter may malfunction and cause loss of control.

T7PX Screen Protector

*Protect the screen from scratches and dirt.

*It's a little smaller than the T7PX screen size, so that is easier attach and stick tight.

*The protector has a front and back backing.

How to attach the protector

- 1 Clean your screen using a glass cleaner with a lint-free microfiber cloth. Wipe off the dust from the screen thoroughly before applying the screen protector. (Dust and dirt are the reasons for air bubbles underneath the protector.)
- 2 Remove one side of the plastic backing. Along one edge about one inch and fold down the backing to expose the protector. Be careful not to touch the screen protector. Align the screen protector along the edge of the screen. Be sure to attach the exposed one inch of the protector film straight to the screen. Press the clean screen protector gently and steadily, press on the screen surface as you peel the backing away. Or gently slide a credit card over the surface, use as a squeegee to get as many of the air bubbles out for you. Slowly press out any air bubbles.
- 3 After attaching the protector is done. Remove the front backing.

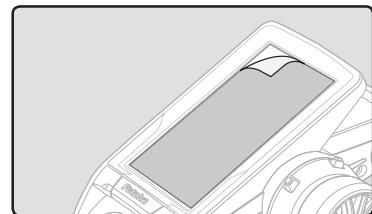
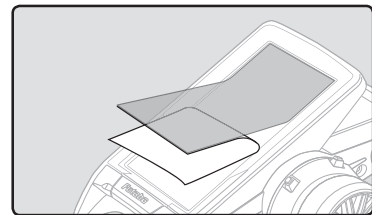
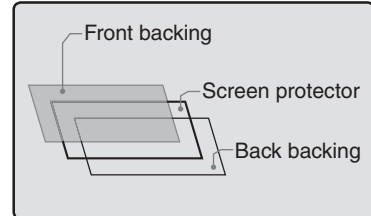

Optional Parts

The following parts are available as T7PX options. Purchase them to match your application. For other optional parts, refer to our catalog.

Transmitter Battery

When purchasing a transmitter battery use the following:

Part name

HT5F1800B (6V/1800mAh) Ni-MH battery

FT2F1700B(6.6V/1700mAh)/2100BV2 (6.6V/2100mAh) Li-Fe battery

Please do not use the transmitter batteries HT5F1800B and FT2F1700/2100BV2 as the receiver's battery.

Telemetry sensors

Usable sensor options(As of July 2017)

- Voltage Sensor (SBS-01V) Measures external power supply voltages up to 100V.
- Temperature sensor (SBS-01T) Perfect for engine head, etc.
- Temperature sensor (SBS-01TE) Used by attaching to a motor, etc.
- RPM Sensor (SBS-01RM) Measures speed over the 0 to 999,900rpm range.
- RPM Sensor (SBS-01RB) Measures speed over the 360 to 300,000rpm range. (Brushless type)
- Current sensor (SBS-01C) Measures external power supply voltages up to 70V, capacity and consumption capacity.
- GPS sensor(SBS-01G) Speed and Altitude

T7PX Angle spacer

This Angle spacer is option part for T7PX. Angle of a steering wheel can be changed. Refer to the page 28 of this manual for means of attachment.

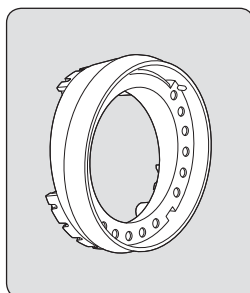

Angle spacer

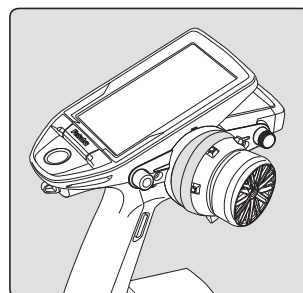

Example of installing angle spacer

T7PX / T4PX Large grip (for transmitter)

This handle grip is larger than the standard handle grip.

It is perfect for those with large hands.

Remove and replace the standard handle grip.

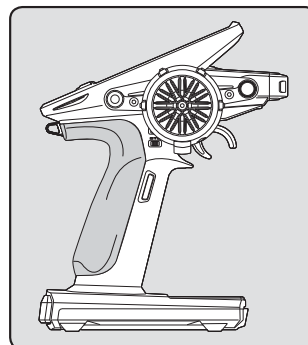

Carbon handle (for transmitter)

An optional carbon handle can be installed to the T7PX. Use the 2.5 hex wrench supplied with the 7PX set to install it. The screws (3x10) are supplied with the optional carbon handle.

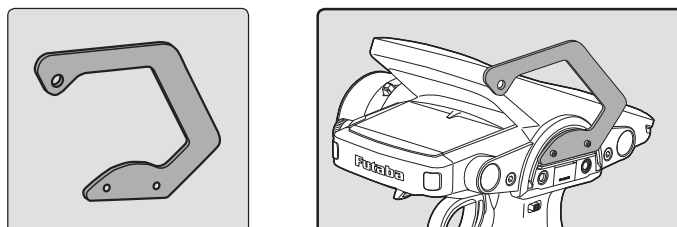

T7PX / T4PX BRAKE LEVER S / SS

This aluminum brake lever is smaller than the width of normal one.

When filing the brake lever, it must be removed from the transmitter body. Otherwise, aluminum powder will enter the body and it will be cause of an electrical problem.

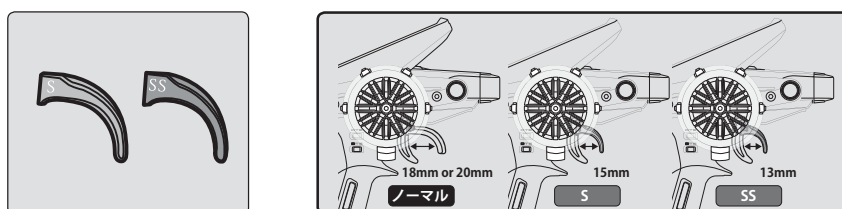

When requesting repair

Before requesting repair, read this instruction again and recheck your system. Should the problems continue, request as follows.

(Information needed for repair)

Describe the problem in as much detail as possible and send the letter along with the system in question.

- Symptom (Including the conditions and when the problem occurred)
- R/C System (Send transmitter, receiver and servos)
- Model (Type of model, brand name and model number or kit name)
- Detailed packing list (Make a list of all items sent in for repair)
- Your name, address and telephone number.

(Warranty)

Read the Warranty card.

- When requesting warranty service, send the card or some type of dated proof purchase.

Federal Communications Commission Interference Statement (for U.S.A.)

This equipment has been tested and found to comply with the limits for a Class B digital device, pursuant to Part 15 of the FCC Rules. These limits are designed to provide reasonable protection against harmful interference in a residential installation.

This equipment generates, uses and can radiate radio frequency energy and, if not installed and used in accordance with the instructions, may cause harmful interference to radio communications. However, there is no guarantee that interference will not occur in a particular installation. If this equipment does cause harmful interference to radio or television reception, which can be determined by turning the equipment off and on, the user is encouraged to try to correct the interference by one or more of the following measures:

- Reorient or relocate the receiving antenna.
- Increase the separation between the equipment and receiver.
- Connect the equipment into an outlet on a circuit different from that to which the receiver is connected.
- Consult the dealer or an experienced radio/TV technician for help.

Battery Recycling (for U.S.A.)



The RBRC™ SEAL on the (easily removable) nickel-cadmium battery and nickel-metal-hydride battery contained in Futaba products indicates that Futaba Corporation is voluntarily participating in an industry program to collect and recycle these batteries at the end of their useful lives, when taken out of service within the United States. The RBRC™ program provides a convenient alternative to placing used nickel-cadmium batteries and nickel-metal-hydride batteries into the trash or municipal waste system, which is illegal in some areas.

You may contact your local recycling center for information on where to return the spent battery. Please call 1-800-8-BATTERY for information on NiCd/NiMH battery recycling in your area. Futaba Corporation's involvement in this program is part of its commitment to protecting our environment and conserving natural resources.

NOTE: Our instruction manuals encourage our customers to return spent batteries to a local recycling center in order to keep a healthy environment.

RBRC™ is a trademark of the Rechargeable Battery Recycling Corporation.

©Copyright 2017. No part of this manual may be reproduced in any form without prior permission. The contents of this manual are subject to change without prior notice. While this manual has been carefully written, there may be inadvertent errors or omissions. Please contact our service center if you feel that any corrections or clarifications should be made.

FUTABA CORPORATION

Makuhari Techno-Garden Bldg. B-6F, 1-3 Nakase, Mihama-ku, Chiba, 261-8555, Japan
Phone: +81-43-296-8259, Facsimile: +81-43-296-8253