

Users Manual
IPS-137

Manual **R²S**

Radar Rain Sensor

Version V5 (6/2007)



 **Lufft**

Table of contents

1	<u>GENERAL REMARKS</u>	3
2	<u>BLOCK DIAGRAM</u>	4
3	<u>OUTPUTS UOUT 1 AND UOUT 2</u>	5
4	<u>COMMISSIONING THE R²S</u>	7
5	<u>CHANGING THE CONFIGURATION</u>	9
6	<u>RS485 PROTOCOL</u>	17
6.1	TELEGRAM SETUP	17
6.2	PHYSICAL CONDITIONS	17
6.3	QUERY OF SENSOR DATA AS A BLOCK (CMD = 0x03)	18
7	<u>DECLARATION OF CONFORMITY</u>	19

1 General remarks

Nowadays, a precipitation measurement can be based on different principles. In addition to the classical tipping bucket, the meteorological sector turns more and more towards differential weight measurement.

The predominant principle in the traffic meteorology is measurement by light barrier.

The new **Radar Rain Sensor (R²S)** from Lufft works with a 24GHz Doppler radar, which is used for measuring the speed of precipitation droplets. Based on the correlation between size and speed of the drops the precipitation quantity is calculated.

The R²S is characterized by the following features:

- Maintenance free precipitation sensor
- Differentiation of rain / snow
- Determination of quantity (Resolution 1mm, 0.1mm, 0.01mm can be selected)
- Interface: RS485 (half duplex) and 2 digital outputs
- Can be configured for replacing an IRSS88
- Can be configured for replacing tipping bucket systems

Important: Precipitation consisting of tiny rain drops or dry snow are not always measured reliably due to a very low back-scattering factor.

You may find more technical details in the internet on:

<http://www.lufft.com>

2 Block diagram

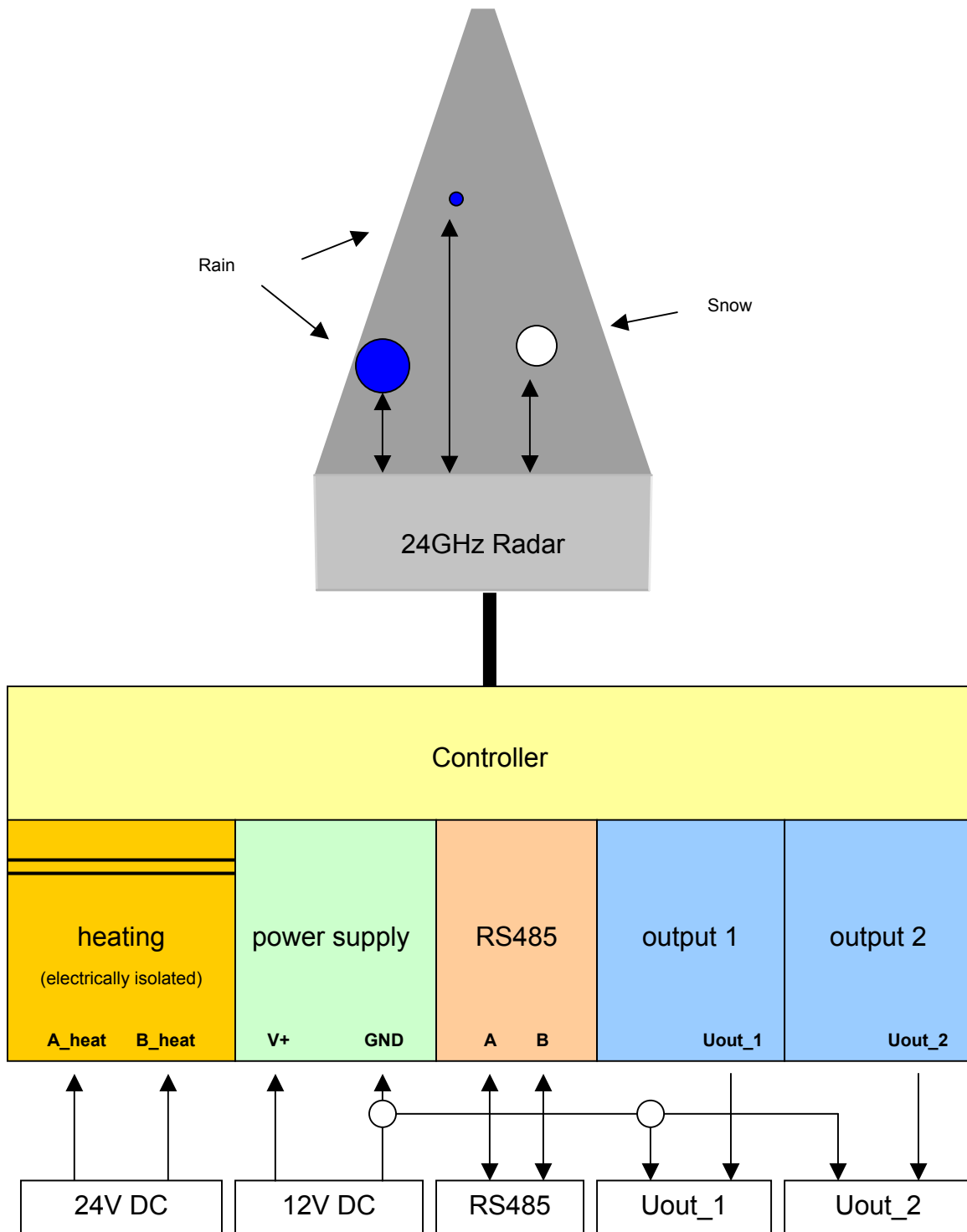

3 Outputs Uout_1 and Uout_2

The digital outputs Uout1 and Uout2 are short-circuit protected High Side switches with integrated pull down resistors.

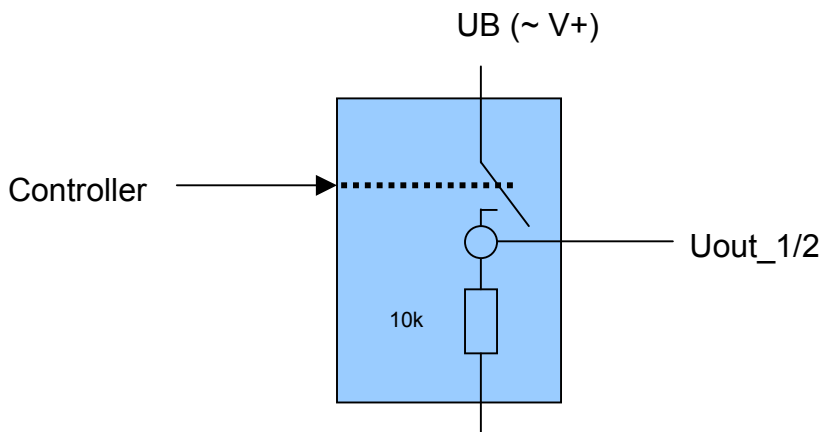

Fig.: Output Uout_1/2

The functions of the outputs are configured through software.

Possible configurations for Uout1 are:

- Output compatible to IRSS88 (POUT)
- Tipping bucket simulation with a resolution of 1mm
- **Tipping bucket simulation with a resolution of 0,1mm (default setting)**
- Tipping bucket simulation with a resolution of 0,01mm

The output impuls of the tipping bucket simulation has a length of typically 50ms

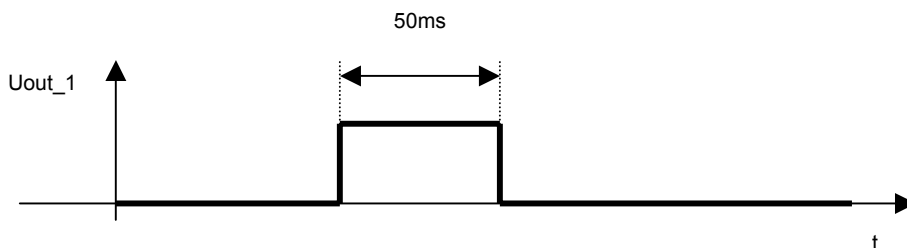

Possible configurations for Uout2 are:

- Output compatible to IRSS88 (SACT)
- State 1:
rain, snowfall = HIGH
no precipitation = LOW.
Every time the accumulated precipitation quantity amounts to 0,01mm, the output is set to HIGH for 2 minutes. If no precipitation has been detected for more than two minutes, the output is set to LOW.
- State 2:
In this configuration, output 2 provides a frequency signal so that a distinction between between rain and snow can be made in an evaluating unit (e.g. data loggers).
No precipitation = Low
Rain: aprox. 10 Hz
Snow: aprox. 20Hz (default settings).

Important: Changing the configuration can only be done with the corresponding hard and software (obtainable from Lufft)!

4 Commissioning the R²S

In the standard version, the R²S is delivered with 10m of lead cable (8 wires)

The following table shows the wire colours, the identification and their meaning:

Identification	Colour	Meaning
A_Heiz	Orange	heating, positive, +24V DC/30VA
B_Heiz	Brown	heating, negative, ground
V+	Red	power supply, positive, +12V DC
GND	Black	power supply, negative, ground
A	Yellow	RS485, A
B	Green	RS485, B
Uout_1	Blue	output 1, reference potential is GND
Uout_2	Purple	output 2, reference potential is GND

Table: R²S cable connection configuration

Connecting the heating element is optional, however necessary if precipitation has to be measured at temperatures below 5°C (41°F). The heating element and power supply are electrically isolated. All supply lines are protected in case of reversed polarity. All outputs are short-circuit protected against the supply voltage.

Included with the R²S is an angle bracket for a mast/pole mounting. The angle bracket can be used on masts with diameters from 40mm to 80mm.

In order to have the R²S function properly, the following mounting conditions must be fulfilled:

- The R²S should always be mounted on top of the mast in order to avoid wrong results through shadowing effects.
- No moving objects (trees, bushes, cars etc.) at a distance of 10m around the sensor.
- Height of the sensor installation >5m.
- Distance to light sources (neon lights, gas discharge lamps, etc.) > 10m.

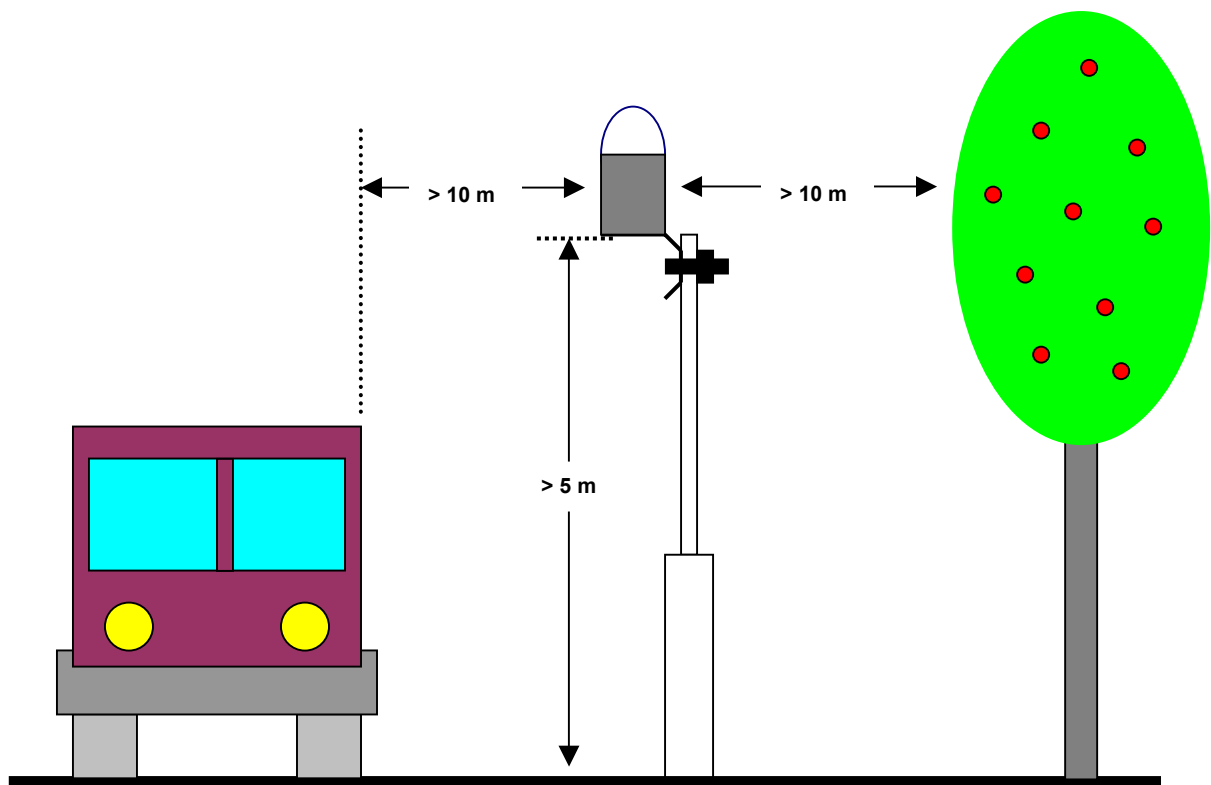

5 Changing the configuration

The configuration can be changed through the RS485 interface of the R²S by using a special software together with a RS232<->RS485 converter.

First connect the R²S to the converter (see illustration). Then link the PC to the converter with the included RS232 cable. The 12V power supply for the R²S must be connected to the green plug "POWER". Special must be taken while connecting the wires (polarity)!

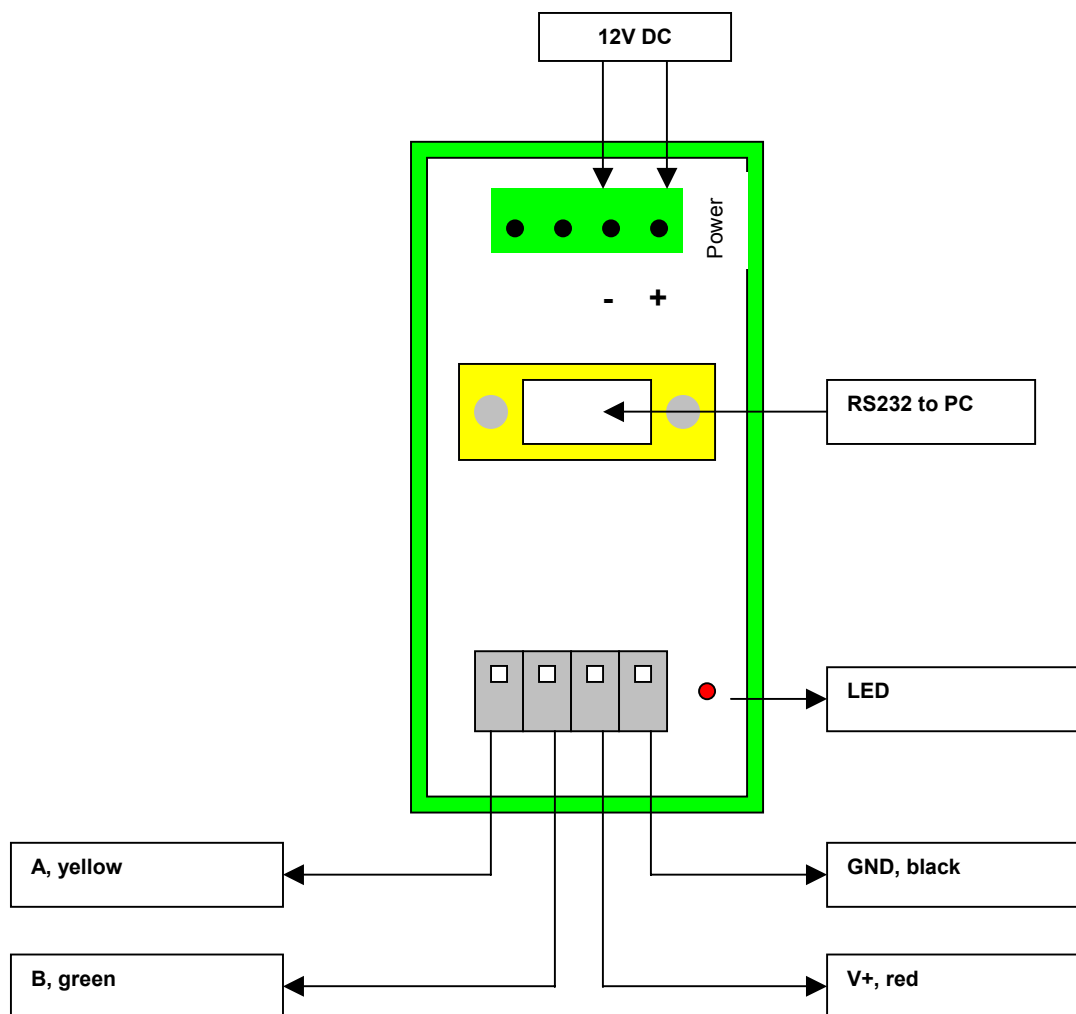
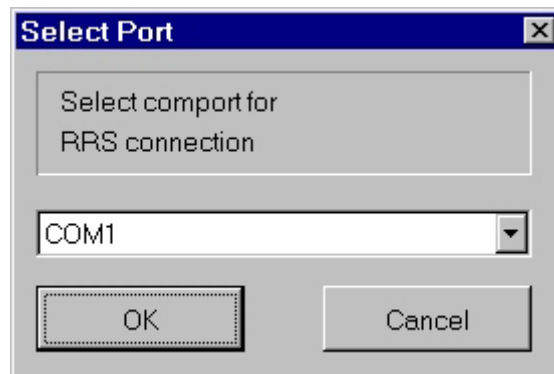

Illustration: Connecting the RS232<->RS485 converter

Install the software on your PC and start the program for configuring the R²S.

First, select the serial interface in **Configuration -> Communication**



Select the **RRS configuration** in the menu **Configuration**.

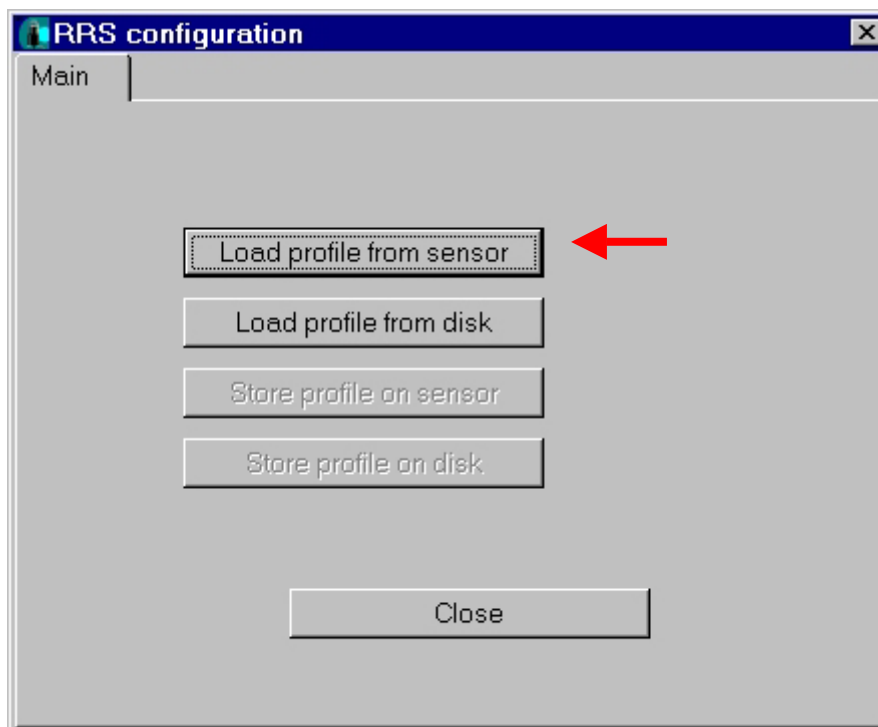

Choose: **Load profile from Sensor**. The PC will now read the sensor configuration. The LED on the converter has to light up during this process. After the configuration has been read successfully, the form on the screen will change and the menu Setup is presented.

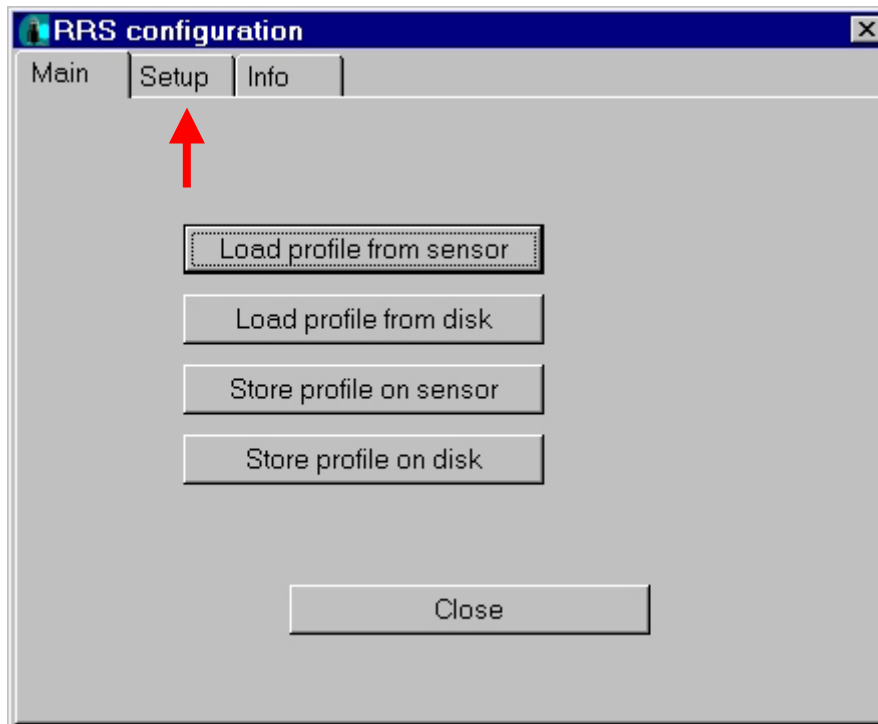

In case of problems, please check the following points:

- Check the supply voltage on the POWER plug of the converter
- Is the RS232 interface set correctly? (try as well on a different PC, if available)
- Check wire connection of the R²S

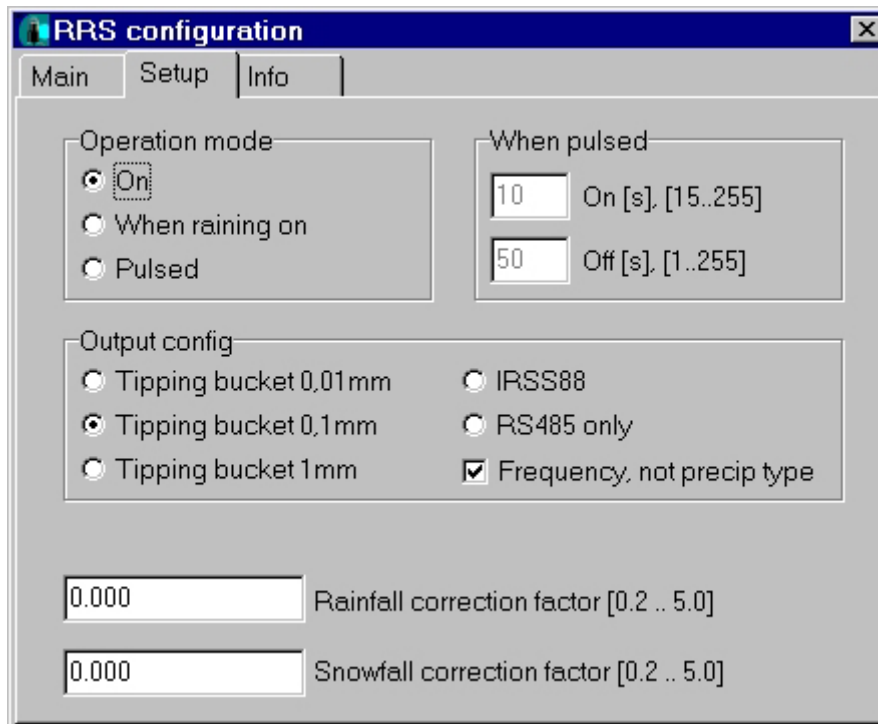
**Operation mode:**

Apart from the operation mode ON (always on) the R²S supports two further operation modes which make sense mainly for systems which require low power consumption (solar systems).

The operation mode „**When raining on**“ switches the radar sensor on and off for the duration of the selected intervals in ON and OFF.

When pulsed	
15	On [s], [15..255]
45	Off [s], [1..255]

If there is any precipitation detected during the regular ON period, the sensor will remain switched on continuously. When the precipitation ends, the sensor will automatically return to clock based service. The precipitation quantity which appears on the output covers the complete ON period.

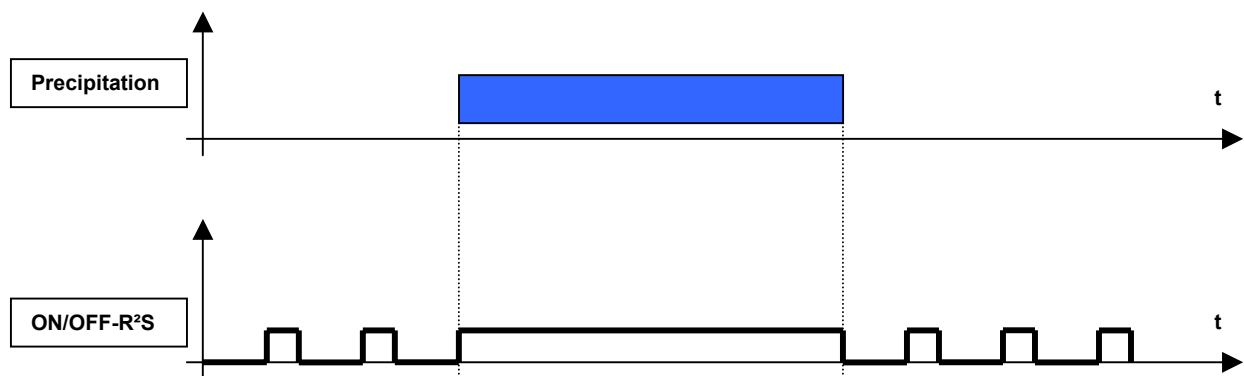

Illustration: Timing Diagram in the “**When raining on**” mode

The operation mode „**Pulsed**“ switches the radar sensor on and off for the duration of the selected intervals in ON and OFF.

When pulsed	
15	On [s], [15..255]
45	Off [s], [1..255]

This clock based operation mode works independently from any precipitation occurring or not. The quantity of precipitation which appears on the output is the quantity which has been measured during the ON period multiplied with the factor $(1 + \text{OFF period} / \text{ON period})$

Example:

0,2mm are measured during the ON period. The On period lasts 15 seconds, the OFF period amounts to 45 seconds.

The value on the output is therefore:

$$0,2\text{mm} \times (1 + 45\text{s}/15\text{s}) = 0,8\text{mm}$$

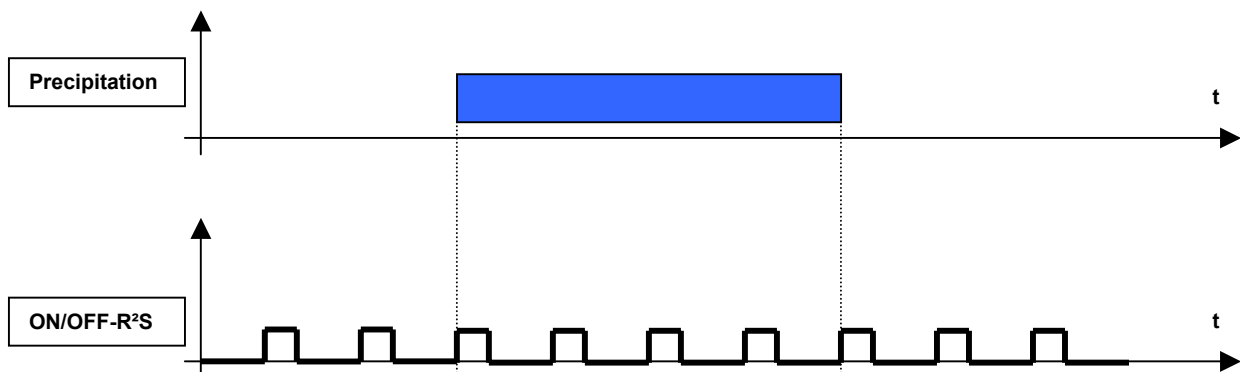
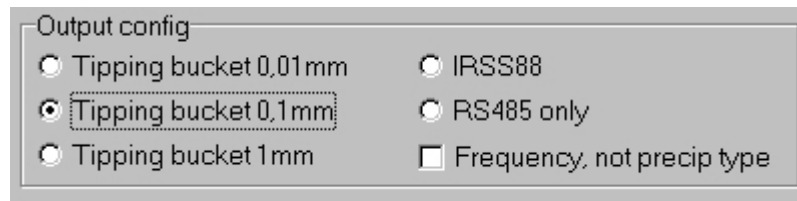

Fig.: Timing Diagram in mode “**Pulsed**”

The function of the outputs Uout_1 and Uout_2 is set in the menu „**OUTPUT config**“.



Output config

<input type="radio"/> Tipping bucket 0,01 mm	<input type="radio"/> IRSS88
<input checked="" type="radio"/> Tipping bucket 0,1 mm	<input type="radio"/> RS485 only
<input type="radio"/> Tipping bucket 1 mm	<input type="checkbox"/> Frequency, not precip type

For the resolution of the precipitation quantity there are 3 different options available (1.0mm, 0.1mm, and 0,01mm). The quantity will always be output on Uout_1. The pulse length is approx. 10ms.

If one of the three possible resolutions is selected, output Uout_2 can assume one of the following functions:

1. Frequency, not precip type

Uout_2 = LOW corresponds to no precipitation

Uout_2 = HIGH corresponds to rain or snowfall

Every time, the quantity of precipitation reaches 0,01 mm the output is set to HIGH for 2 minutes. If no precipitation has been detected for more than 2 minutes, the output is set to LOW.

2. Frequency, not precip type

Uout_2 = LOW corresponds to no precipitation.

Uout_2 = Frequency of 10 Hz corresponds to rain

Uout_2 = Frequency of 20 Hz corresponds to snowfall

The frequency signal on the output allows to distinguish between rain and snow with a corresponding evaluation unit.

When the R²S is used in the IRSS88 mode the function **POUT** of the IRSS88 is emulated on the output Uout_1 and the function **SACT** on the output Uout_2.

In the operation mode „**RS485 only**“ both outputs Uout_1 and Uout_2 are set to LOW. The data can only be read out over the RS485 interface.

Important: The output configuration "**RS485 only**" will only work in combination with the operation mode "**ON**" but does not support the power saving conditions „*When raining on*“ or „*Pulsed*“!

6 RS485 Protocol

6.1 Telegram setup

descending byte series:

Byte number	Meaning	Abbr.	range
1	Telegram start	STX	0x02
2	Identification	ID	0 ... 250
3	Length	CNT	1 ... 255
4	Command	CMD	0 ... 255
5 ... n	additional data	D0 ... Dn	0 ... 254 Bytes
n + 1	Block check	CRC_L	16 Bit CRC check sum from ID until the last Data byte
n + 2		CRC_H	
n + 3	End of telegram	ETX	0x03

6.2 Physical conditions

RS485 – 2 wire (half duplex)

Data bits: 8

Stop bits: 1

Parity: none

Baudrate : 19200 Baud (Default setting)

Check sum: 16 Bit CRC from Ident. byte (ID) until the last data byte

CRC-Polynomial: $x^{16} + x^{12} + x^5 + 1$ (LSB first) mode

Timeout: Answer from the slave must be available max. 0.5 Sec. after request from the master

In case of timeout or erroneous answer from the RRS the request from the supplied PC program is repeated twice max.

6.3 Query of sensor data as a block (CMD = 0x03)

Master: STX, ID, CNT = 1, CMD = 0x03, CRC_L, CRC_H, ETX

Slave: STX, ID, CNT = x, CMD = 0x03, D0 ... Dn (see table below), CRC_L,
CRC_H, ETX

Slave D0 ... Dn	Meaning
D0, D1	Precipitation quantity 0..655,35 mm -> 0..65535
D2	Type of precipitation 0/1/2
D3	Internal use only 0..255

Type of precipitation:

Precipitation quantity = 0mm and D2=0 => no precipitation

Precipitation quantity > 0mm and D2=1 => Rain

Precipitation quantity > 0mm und D2=2 => Snow

Important: On request CMD = 0x03, the sensor provides the accumulated precipitation quantity, evaluated between the actual and previous request.

7 Declaration of Conformity

Declaration of EEC Conformity

For the following product

R²S, Order Reference 8367.xx

it is hereby confirmed that they comply with the principal safety requirement which are set out in the guidelines of the council for the unification of legal regulations of the member states concerning electromagnetic compatibility (89/336/EEC) and 1999/5/EG.

This declaration is valid for all specimens which are manufactured according to the current production drawings – which are the component of this declaration.

The manufacturer is responsible for this declaration

Issued by

G.LUFFT
Mess- u. Regeltechnik GmbH
Gutenbergstraße 20
D-70736 Fellbach
Postfach 4252
D-70719 Fellbach



Fellbach-Schmidlen, 14.6.2002

Klaus Hirzel

Declaration of Conformity for USA

This device complies with Part 15 of the FCC Rules. Operation is subject to the following two conditions:

- (1) This device may not cause harmful interference, and
- (2) this device must accept any interference received, including interference that may cause undesired operation.

Usually this is followed by the following FCC caution:

Any changes or modifications not expressly approved by the party responsible for compliance could void the user's authority to operate this equipment.

Declaration of Conformity for CANADA

Operation is subject to the following two conditions:

- (1) this device may not cause interference, and (2) this device must accept any interference, including interference that may cause undesired operation of the device.

Usually this is followed by the following RSS caution:

Any changes or modifications not expressly approved by the party responsible for compliance could void the user's authority to operate this equipment

DATA SHEET

Product Family: K-Band Transceivers

**K-Band Transceiver
with two integrated patch antennas, RF- and IF-pre-amplifier
IPM-137 (and variant IPM-137_US)**

Description:

- radar-based motion detector
- available in different frequency ranges:
IPM-137; ETSI-compliant frequency
IPM-137_US; FCC-compliant frequency
- advanced PHEMT-oscillator with low current consumption
- RF-pre-amplifier for lowest noise operation
- split transmit and receive path for maximum gain
- mono (single channel) operation
- IF-pre-amplifier, bandwidth limited for lowest noise performance
- compact outline dimensions

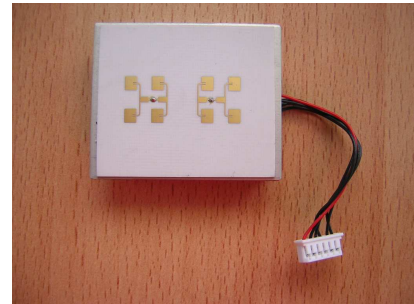
**Absolute Maximum Ratings:**

Parameter	Symbol	Rating	Units
supply voltage	V_{CC}	5.5	V
operating temperature (out of spec)	T_{OP}	- 40 / + 85	°C
storage temperature	T_{STG}	+ 90	°C

Electrical Characteristics:

Parameter	Symbol	min.	typ.	max.	units	comment
transmit frequency	$f_{IPM-137}$	24.000	24.125	24.250	GHz	
	$f_{IPM-137_US}$	24.075	24.125	24.175	GHz	
output power (EIRP)	P_{out}		18		dBm	
temperature drift	Δf		- 500		kHz/°C	
antenna pattern	horizontal		65		°	azimuth
	vertical		40		°	elevation
side lobe suppression	horizontal		15		dB	azimuth
	vertical		15		dB	elevation
IF output	voltage offset		$V_{CC}/2$		V	
IF-amplifier	gain		46		dB	
	bandwidth		50 – 1.5k		Hz	
supply voltage	V_{CC}	4.75	5.0	5.25	V	
supply current	I_{CC}		60		mA	IF-amp included
operating temperature	T_{OP}	- 20		+ 60	°C	
outline dimensions		~ 42 x 50 x 11				compare drawing

Interface:

The sensor provides a 2 mm pitch 6 pin connector Molex P/N 51004-0600.

Pin #	Description	In/Out	Comment
1	not connected		
2	V _{CC}	input	supply voltage (+5 V)
3	GND	input	analog ground
4	IF1	output	signal output
5	not connected		
6	not connected		

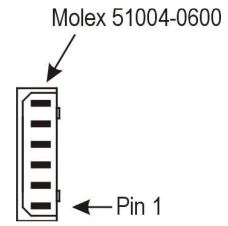

mates with: Molex P/N 53014, 53015 and 53025

Mechanical Outlines:

(dimensions in mm)

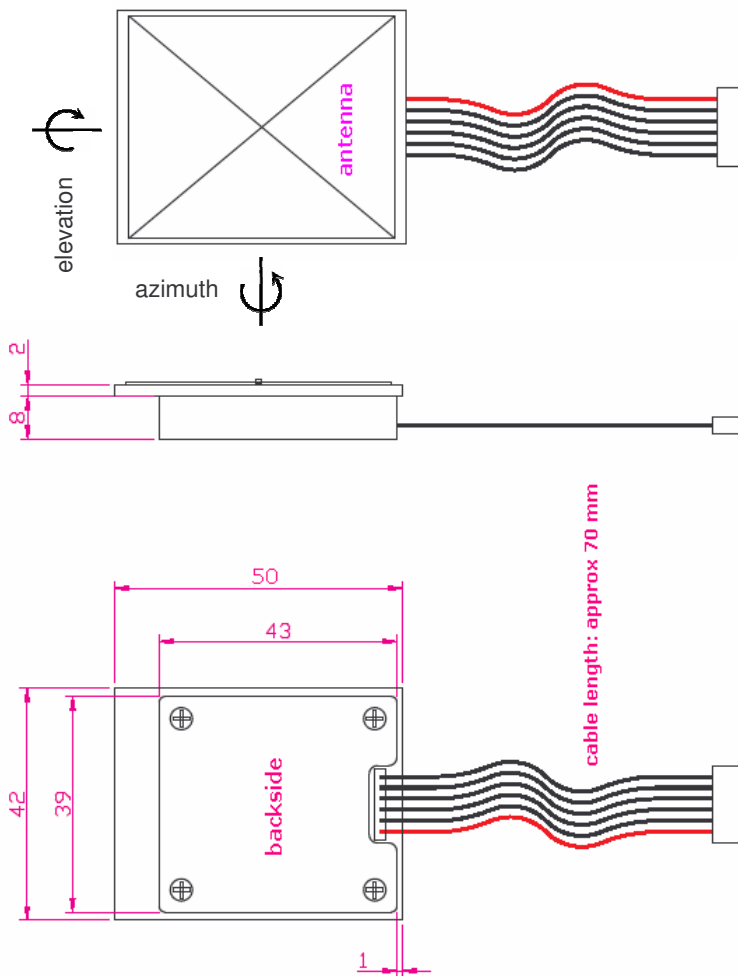

Certification and environment protection:

InnoSenT GmbH has established and applies a quality system for:
Development, production and sales of radar sensors for commercial and industrial sensors

An audit was performed, Report No. 010350 Proof has been furnished that the requirements according to DIN EN ISO 9001:2000 are fulfilled.



This InnoSenT product is compliant to the restriction of hazardous substances (RoHs – European Union directive 2002/95/EG).



InnoSenT Approval

This data sheet contains the technical specifications of the described product. The technical specifications of this data sheet are approved:

InnoSenT GmbH
Am Roedertor 30
97497 Donnersdorf
GERMANY

Customer Approval

This data sheet contains the technical specifications of the described product. Changes of the specifications must be in written form. All previous versions of this data sheets are no longer valid.

The technical specifications of this data sheet are approved:

G. Luft Mess- und Regeltechnik GmbH
Gutenbergstr. 20
70736 Fellbach

Signature(s)

Name(s)

company stamp

Contact Information:

InnoSenT GmbH
Am Roedertor 30
97499 Donnersdorf
Germany

Phone: +49 (0) 9528-9518-0
Fax: +49 (0) 9528-9518-99

E-Mail: info@InnoSenT.de
Web: www.InnoSenT.de