



INNOVATIVE COMMUNICATION SOLUTIONS



Installation and Operating Manual

LTE - Upper C Band, Bi-Directional Amplifier

BDA-LTE/UC-33/33-90-C



TABLE OF CONTENTS

PARAGRAPH	PAGE NO
OVERVIEW	3
BLOCK DIAGRAM DESCRIPTION	3
BLOCK DIAGRAM DRAWING (Figure 1)	4
ELECTRICAL SPECIFICATIONS	5
MECHANICAL SPECIFICATIONS	6
ENVIRONMENTAL CONDITIONS	6
RF EXPOSURE WARNING	6
CONNECTIONS	7
MECHANICAL OUTLINE DRAWING (Figure 2 & 2a)	8
INSTALLATION	9
OPERATION	10
FRONT PANEL (Figure 3)	11
BACK PANEL (Figure 3a)	11
DIAGNOSTICS GUIDE	12

OVERVIEW:

The BDA-LTE/UC-33/33-90-C assembly enhances the coverage area of radio communications in buildings and RF shielded environments.

The BDA-LTE/UC-33/33-90-C has dual RF paths (Forward / Reverse) to improve coverage in two distinct frequency bands.

The unit features low noise figure and wide dynamic range. It is based on a dual duplexed path configuration with sharp out of band attenuation allowing improved isolation between the receiving and transmitting paths.

BLOCK DIAGRAM DESCRIPTION:

Refer to Figure 1 for the following discussion.

The BDA-LTE/UC-33/33-90-C Downlink path receives RF signals from the base station, amplifies the signal and transmits the signal into a Distributed Antenna System at the direction of the mobiles. The signal travels over a DAS medium that then dissipates the signal to the Mobile subscribers. The BDA-LTE/UC-33/33-90-C Uplink path receives RF signals at the Mobile side from the DAS system, then amplifies it, and transmits the amplified signal to the base station. The Uplink and Downlink occupy two distinct dedicated frequency bands, each Uplink and Downlink band is 11MHz wide.

For LTE Upper C Band, the frequency allocations are as follows:

Uplink: 776 - 787 MHz
Downlink: 746 – 757 MHz

Four diplexers isolate the paths and route each signal to the proper amplifying channel.

An Automatic Level Control (ALC) allows for output power limiting. A variable step attenuator gives 0 – 30 dB of attenuation in 2 dB steps. The use of these controls is covered in the “OPERATION” section, later in this document.

BLOCK DIAGRAM DRAWING: (Figure 1)

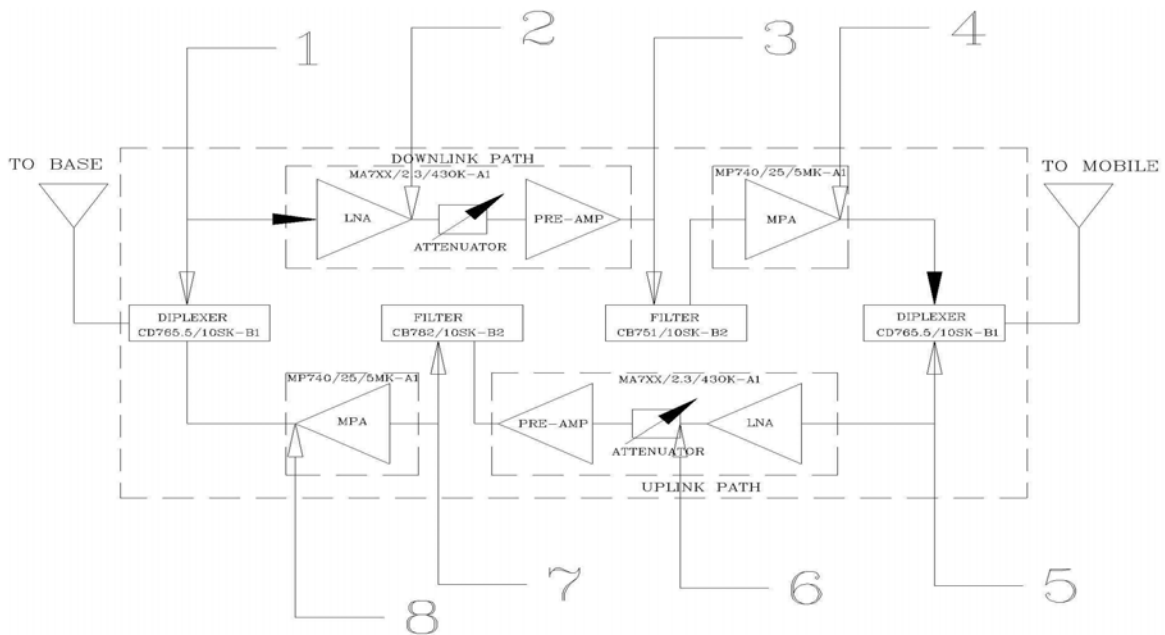

1. Input Uplink Diplexer – has low bandpass insertion loss and high selectivity for one distinct downlink/uplink frequency band.
2. Downlink Pre-amp's – are low noise amplifiers that drive the Downlink PA's and offer 45dB Gain.
3. Pre-Selector Filter - Downlink
4. Downlink PA's – are power amplifiers with an ALC circuit which offer 50dB Gain.
5. Output Downlink Diplexer - has low bandpass insertion loss and high selectivity for one distinct downlink/uplink frequency band.
6. Uplink Pre-amp's – are low noise amplifiers that drive the Uplink LPA's and offer 45dB Gain.
7. Pre-Selector Filter - Uplink
8. Uplink LPA's – are power amplifiers with an ALC circuit which offer 50dB Gain.

ELECTRICAL SPECIFICATIONS:

Frequency Range	: UL 776 – 787 MHz DL 746 – 757 MHz
Pass band Gain @ min attenuation	: 90 dB (Min.)
Variable Step Attenuator Range (2-dB steps)	: 0-30 dB
Pass band Ripple	: ±2.0 dB (Typ.)
Noise Figure (Uplink) @+25°C at max gain	: 5.0 dB (Typ.)
3rd Order Intercept point	
Downlink	: +53 dBm (Typ.)
Uplink	: +53 dBm (Typ.)
Output Power (Composite)*	
Downlink	: +33 dBm (Typ.)
Uplink	: +33 dBm (Typ.)
Isolation between Up/Down Link	: 100 dB (Min.)
Input/ Output Impedance	: 50 Ohms
*SFDR	: 120 dB/Hz ^{2/3}
VSWR (Input/Output)	: <1.5: 1
Power Supply	: 110VAC/1.1 Amps : 220VAC/0.55 Amps : 50 to 60 Hz

MECHANICAL SPECIFICATIONS:

<u>Size</u>	: 18.1 x 14.0 x 6.7 inch : (459.74 x 355.60 x 170.18 mm)
<u>RF Connectors</u>	: N-Type Female
<u>Weight</u>	: 35.0 Lbs. (16 kg.) approx.

ENVIRONMENTAL CONDITIONS:

The unit is designed for indoor applications:

Operating temperature: - 20°C to + 50°C

Storage temperature: - 50°C to + 90°C

FCC NOTE:

The Federal Communications Commission (FCC) has tested this product and found it to comply with their RF Exposure Requirements, pursuant to FCC Part 27.

RF EXPOSURE WARNING:

In order to comply with the FCC RF exposure requirements, the BDA-LTE/UC-33/33-90-C antenna installation must comply with the following:

The outdoor antenna (Yagi type or similar directional antenna if off air donor signal used) must be installed so as to provide a minimum separation distance of 0.3 meters (60 cm) between the antenna and persons within the area. (This assumes a typical antenna with gain of [10.1 dBi, VSWR ≤ 1.5:1, Zo= 50 ohms, and a cable attenuation between 1-10 dB).

The indoor antenna (Omni directional or leaky cable) must be installed so as to provide a minimum separation distance of at least 8 inches (20 cm) between the indoor antenna connected to the RF booster and the human user's body within the area. (This assumes a typical wide-beam type antenna with gain of 0-2 dBi, VSWR ≤ 2:1, Zo= 50 ohms, and a cable attenuation of between 1-10 dB).

CONNECTIONS:

The BDA AC power is accepted through a circular 3-wire female plug with phase, neutral and ground leads. The AC power is wired to a high efficiency DC switching power supply which is CE and UL approved. The power supply runs the amplifiers and the LED indicators. The metal enclosure of the BDA is connected to ground.

A 7-pin circular connector provides failure and Oscillation Detect alarms output dry contacts, Normally Open and Normally Closed (see diagrams on page 8).

The RF connections are made via two type “N” female connectors. The RF connector labeled “BASE” must be connected to the antenna pointing towards the base station. The RF connection labeled “MOBILE” must be connected to the antenna / passive DAS facing the area to be covered by the BDA.

The RF connections must be made through cables with characteristic impedance of 50 ohms.

The isolation between the base station antenna and the mobile antenna should be at least 12 dB higher than the BDA gain. Isolation less than this value can cause gain ripple across the band. Isolation equal to or less than the BDA gain will give rise to oscillations which will saturate the amplifiers and possibly cause damage to the BDA.

All signal boosters must detect feedback or oscillation and deactivate the uplink transmitter within ten seconds of detection - FCC

This BDA includes the ODSC feature. ODSC is Oscillation Detect, Display and Automatic Shutdown of all Amplifiers. When the unit’s ALC threshold is reached, the BDA will automatically shutdown the amplifiers until oscillation is corrected, only then will the BDA resume regular operation.

BDA-LTE/UC-33/33-90-C Mechanical Outline (Figure 2):

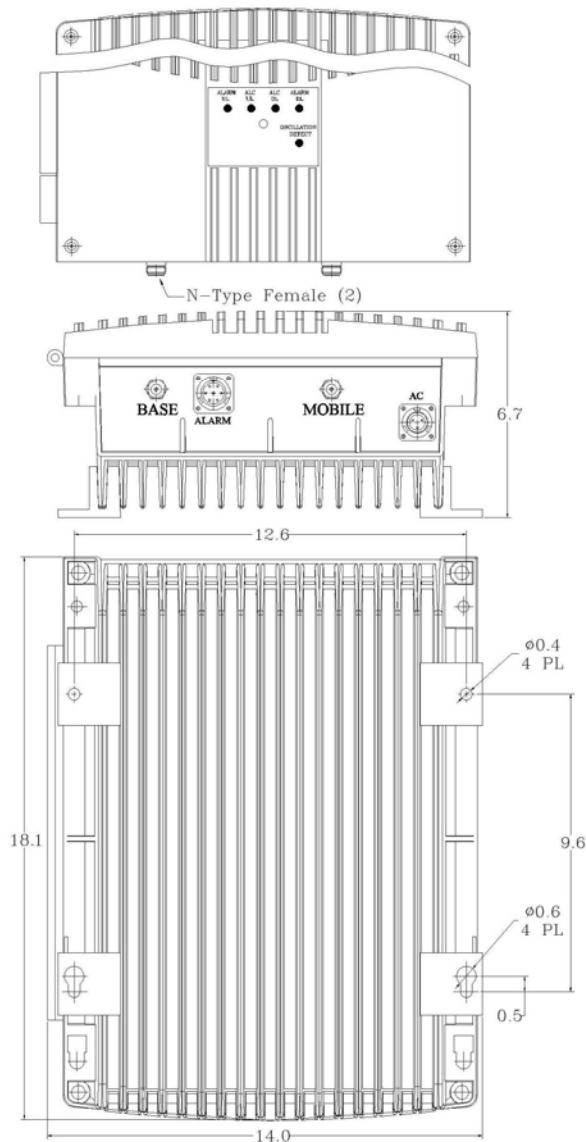

PIN OUT OPTION ODSCRM7 Alarm/Optional Power Supply Pinout (Relay States Refer To NON Alarm Condition)

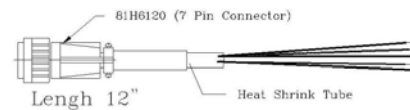
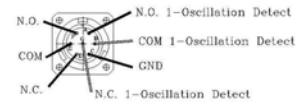

OPTIONAL ALARM CONDITIONS: (Figure 2a)

The alarm monitors current of both uplink and downlink amplifiers. An alarm condition will occur if either uplink or downlink amplifiers are over or under its current tolerance. Also Oscillation detect Alarm would be provided on the other pair dry contacts.

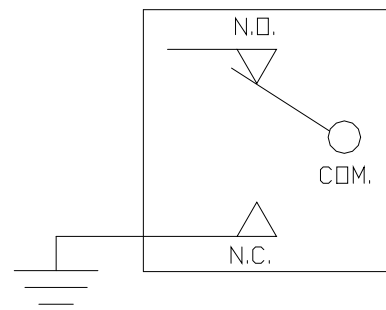

(Relay Shown in Non-Alarm Condition)

INSTALLATION:



WARNING. This is **NOT** a **CONSUMER** device. It is designed for installation by **FCC LICENSEES** and **QUALIFIED INSTALLERS**. You **MUST** have an **FCC LICENSE** or express consent of an FCC Licensee to operate this device. Unauthorized use may result in significant forfeiture penalties, including penalties in excess of \$100,000 for each continuing violation.

DO NOT APPLY A.C. POWER TO THE RHBDA UNTIL CABLES ARE CONNECTED TO BOTH PORTS OF THE RHBDA AND THE ANTENNAS.

1. Mount the BDA on the wall with the RF connectors pointing DOWN. Using appropriate screws and anchors, attach the BDA to the wall at the four mounting holes on the side flanges.
2. Ensure that the isolation between the donor antenna and the service antenna is at least 12 dB greater than the BDA gain. (Use the higher of the Uplink and Downlink gains reported on the BDA test data sheet).
3. Connect the cable from the donor antenna to the BDA connector labeled "BASE" and the cable from the service antennas to the BDA connector labeled "MOBILE".
4. Open the main access front panel of the BDA (using the Allen Key located on the side of the BDA) and verify that both of the attenuator's are positioned to its maximum setting (30 dB). Close the main panel.
5. Connect the AC power cord to the BDA and then to the power source. Verify that the "Power ON" Green LED indicator is illuminated.

Installation of the BDA is now complete. To adjust the gain controls to suit the specific signal environment, refer to the next section of the manual.

Note: *For repeat installations of existing equipment, make sure the attenuation is positioned to its maximum setting (30 dB). After verification of the attenuation, follow the above steps starting with step 1.*

OPERATION:

Refer to Figure 3 & 3a for adjustment access location, connectors and labels.

Variable Step Attenuator

BDA gain can be reduced by up to 30 dB in 2 dB steps using the variable step attenuator. Gain adjustment is made with rotary switches accessible via the access door on the BDA enclosure. Arrows on the shafts of these switches point to the value of attenuation selected. BDA gain can be determined by subtracting the attenuation value from the gain reported on the BDA Test Data Sheet for that side of the unit. The attenuators are labeled for Uplink and Downlink.

ALC (Automatic Level Control)

To minimize intermodulation products, each amplifier in the BDA contains an ALC feedback loop. The ALC circuit senses the output power and limits it to the factory preset level of +33 dBm UL and +33 dBm DL.

ALC **function** is located in each power amplifier. A red LED indicator located on the Front main panel (see figure 3) illuminates when output power meets or exceeds the ALC preset point.

To establish proper operating gain on the Uplink and Downlink sides, start with the Downlink. Observe the red LED indicator on the Downlink amplifier. Units are shipping with maximum attenuation. Decrease attenuation one step at a time until the red LED is lit. Then, using the Downlink step attenuator, increase the attenuation until the red LED goes off. Repeat the process for the Uplink. . This setup should be done under RF signal transmit for either path the level indicator is accurate to +/- 0.4 dB of the ALC set point.

ODSC / ODSCRM7

To minimize interference with other RF systems, this unit includes an Oscillation detection module that continuously monitors the BDA operation, in a case of Oscillation detection inside the BDA, the detector will shut down all the amplifiers to avoid RF interference with other systems in the area, when the Oscillation condition passes or is resolved, the ODSC operation will turn on all the amplifiers, returning to regular operation. The ODSCRM7 module will allow Oscillation detect / display & shutdown of all amplifiers with remote monitoring via 7-Pin connector. A red LED located on the front panel (see figure 3) illuminates when OSC is detected.



Note: Operation of BDA-LTE-UC33/33-90-C at maximum gain with greater than - 40 dBm average power incidents on the MOBILE or BASE ports could cause damage to the BDA.

WARNING:

Input Signal Level
above +10 dBm may cause
damage to system

FRONT PANEL CONNECTORS (Figure 3)



Optional Alarm Connector

AC Power Connector

INNER PANEL UL/DL GAIN ADJ (Figure 3a)



Uplink ALC and Alarm LED's

Downlink ALC and Alarm LED's



Oscillation Detect Alarm LED

DIAGNOSTICS GUIDE

The BDA provides long term, care-free operation and requires no periodic maintenance. There are no user-serviceable components inside the BDA.

This section covers possible problems that may be related to the installation or operating environment.

Gain Reduction

Possible causes: Defective RF cables and RF connections to antennas, damaged antenna or Leaky cable.

Excessive Intermodulation or Spurious

Possible causes: Amplifier oscillation caused by insufficient isolation. The isolation between two antennae is given by the equation:

$$\text{Isolation} = 92.5 + 20 \text{ Log } (F \times D) - G_t - G_r$$

Where:

F = frequency (GHz)

D = separation (Km)

G_t = transmit antenna gain (in the direction of the receive antenna).

G_r = receive antenna gain (in the direction of the transmit antenna).

For the LTE 750 MHz frequencies, the antenna isolation at 100 m separation is approximately 93.3 dB for Omni-directional antennas or leaky cable (0 dB gain). To increase isolation, the antennas should have higher directivity and must be pointed away from each other.

Occasional Drop-out of some Channels

Possible causes: One channel with very strong power dominates the RF output of the amplifier.

Full Band Directional Antenna

Model #: TDJ-700/2500YG



Applications

- LTE/CDMA800/GSM/3G/WLAN/Wimax
- Wireless communications and data transmission system \ Repeater
- Indoor and outdoor directional coverage

Features

- Broad band, Stable performance
- Low VSWR, High gain
- Support the popular communications system currently
- Sealed with radome, Strong protection ability
- Supplied with down-tilt bracket kit

Specifications

Model	TDJ700-2500YG			
Freq.Range-MHz	698-800	800-960	1700-2700	
Beamwidth	E-°	65	60	50
	H- °	85	85	60
F/B Ratio-dB	≥15	≥20	≥20	
Gain-dBi	7.5	8.5	10	
VSWR	≤1.5			
Impedance-Ω	50			
Polarization	Vertical			
Max.Power-W	100			
Connector	N female or customized			
Dimensions-mm	293×210×65			
Weight-Kg	0.92			
Mast Diameter-mm	φ40 to 50			
Note: When installing, you should make the side with a little hole face down to prevent the radome from raining.				

Installation Sketch

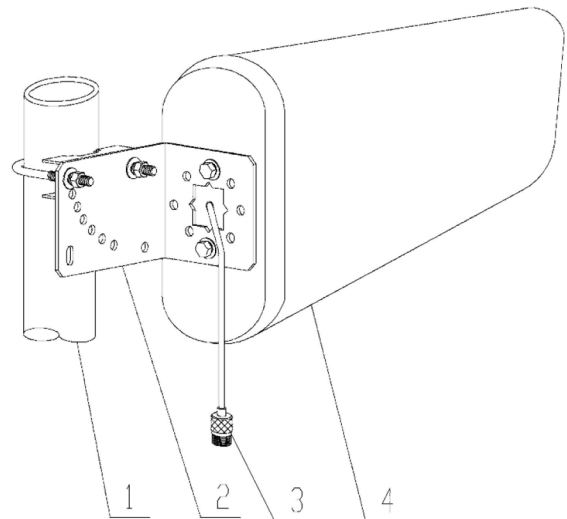

1. Mast(user-provide) ;
2. "L" mounting kit;
3. connector;
4. antenna



Model #: TQI-4FC-5
Wide Band High Gain Ceiling Antenna

Specifications		
Model	TQI-4FC-5	
Frequency Range-MHz	698~960	1710~2700
Gain-dBi	2	5
VSWR	≤2.5	698~806
	≤1.5	806~960/1710~2500
	≤2.0	2500~2700
Impedance-Ω	50	
Polarization	Vertical	
Maximum Power (W)	100	
Connector	N-Female	
Dimension-mm	φ170×72	
Weight-Kg	0.4	
Mounting way	Fixed with Nut	



Applications

- 698~960/1710~2700MHz Band
- Indoor coverage system
- Wireless communication system
- Wireless data transmission
- TDD/FDD-LTE

Features

- 698~960/1710~2700MHz band
- Low VSWR
- Support current main popular communication system
- ABS Radome
- Ceiling mount, easy to install

Installation

