



**INSTALLATION  
AND  
OPERATING MANUAL  
FOR  
BDA-SMR-1/25W-90-O  
OUTDOOR REPEATER**



# TABLE OF CONTENTS

<b>PARAGRAPH</b>	<b>PAGE NO</b>
BDA OVERVIEW	3
BDA BLOCK DIAGRAM DESCRIPTION	3
OPTIONAL EQUIPMENT OVERVIEW	3
BDA BLOCK DIAGRAM DRAWING (Figure 1)	4
ELECTRICAL SPECIFICATIONS	5
MECHANICAL SPECIFICATIONS	6
ENVIRONMENTAL CONDITIONS	6
BDA CONNECTIONS	6
OPTIONAL EQUIPMENT OVERVIEW	7
MECHANICAL OUTLINE DRAWING (Figure 2 & 2a)	8
OPTIONAL BATTERY BACK-UP CONFIGURATION (Figure 3)	9
RF EXPOSURE WARNING	10
BDA INSTALLATION	11
BDA OPERATION	12
VARIABLE GAIN ADJUSTMENT	13
ALC ADJUSTMENT	14
DIAGNOSTICS GUIDE	14

## **BDA OVERVIEW:**

The BDA assembly extends the coverage area of radio communications in buildings and RF shielded environments.

The unit features low noise figure and wide dynamic range. It is based on a duplexed path configuration with sharp out of band attenuation allowing improved isolation between the receiving and transmitting paths.

## **BDA CIRCUIT DESCRIPTION:**

Refer to figure 1 for the following discussion.

The BDA Downlink path receives RF signals from the base station and amplifies and transmits them to the subscriber. The BDA Uplink path receives RF signals from the subscriber and amplifies and transmits them to the base station. The Uplink and Downlink occupy two distinct frequency bands. For example, the SMR frequency bands are as follows: *806-821 MHz for the Uplink and 851-866 MHz for the Downlink*. Two diplexers isolate the paths and route each signal to the proper amplifying channel.

A selectable Automatic Level Control (ALC) allows for output power limiting. A Manual Gain Control (MGC) provides continuous control of amplifier gain. The use of these controls is covered in the "OPERATION" section, later in this document.

# Figure 1

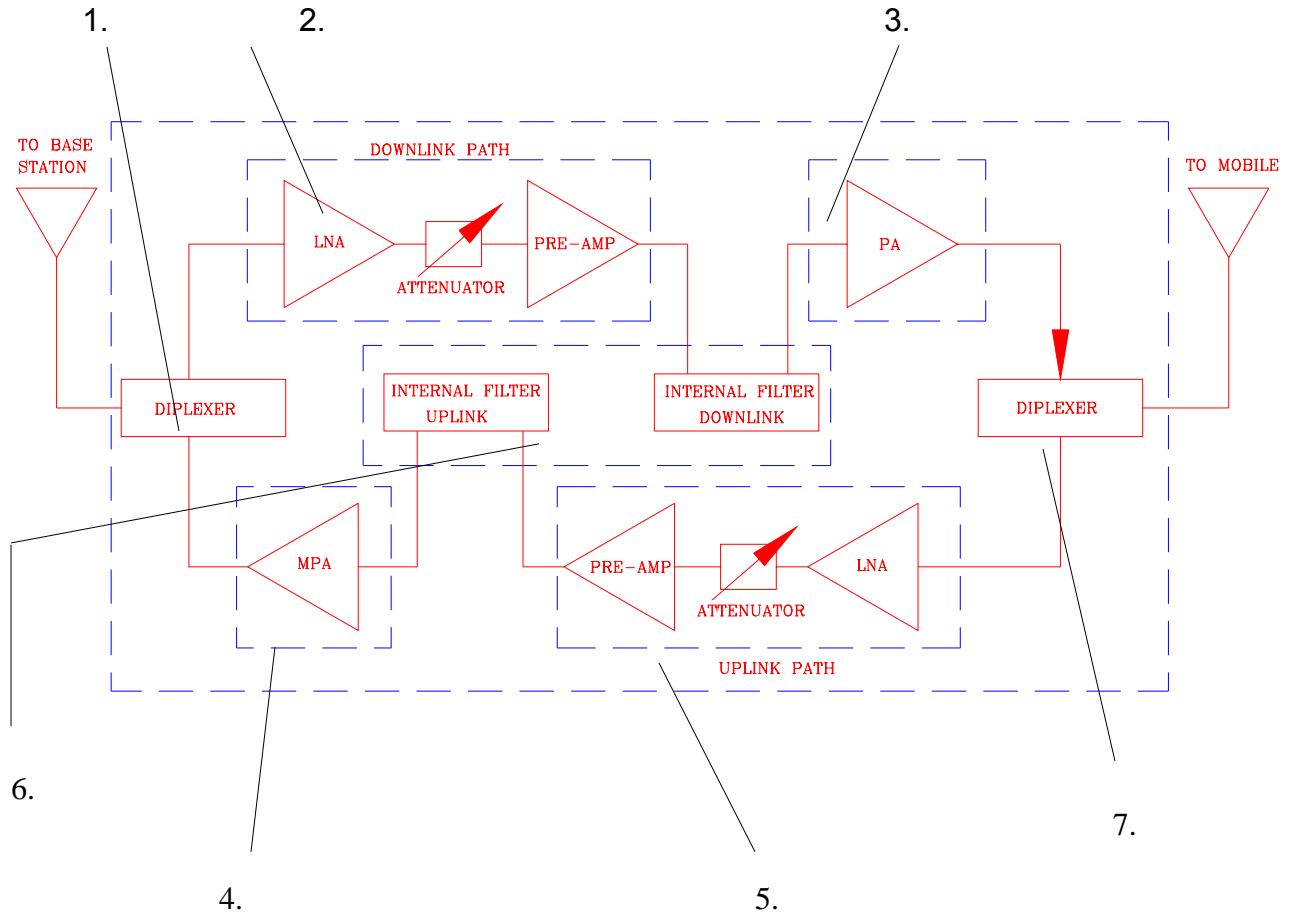

## BDA Block Diagram

1. Uplink Diplexer - has low bandpass insertion loss and high selectivity
2. Downlink Pre-amp - is a low noise amplifier that drives the Downlink PA and offers 46dB Gain
3. Downlink PA – is a power amplifier with an ALC circuit which offers 43dB Gain
4. Uplink MPA – is a medium power amplifier with an ALC circuit which offers 43dB Gain
5. Uplink Pre-amp - is a low noise amplifier that drives the Uplink MPA and offers 46dB Gain
6. Filters used on High-Gain Repeaters (90dB) to provide better isolation between Tx & Rx frequencies and to aid the diplexer rejection.
7. Downlink Tx filter is enhanced for High Power applications, preventing arching when the power amplifier approaches the 1dB compression point.

## ELECTRICAL SPECIFICATIONS:

Frequency Range	
Uplink	: 806-821 MHz
Downlink	: 851-866 MHz
Pass Band Gain @ min attenuation	: 90 dB (typ.)
Variable Step Attenuator Range (2-dB steps)	: 0-30 dB
Pass band Ripple	: ±1.5 dB (typ)
20 dB Bandwidth	: 20 MHz
Noise Figure @+25°C at max gain	: 4.0 dB max.
3rd Order Intercept point	
Uplink	: +45 dBm (typ)
Downlink	: +55 dBm (typ)
*Output Power @ 1dB Compression	
Uplink	: +32 dBm (typ)
Downlink	: +44 dBm (typ)
*ALC Factory Set Point	
Uplink	: +25 dBm
Downlink	: +35 dBm
Isolation between Up/Down Link	: 100 dB min.
Input/ Output Impedance	: 50 Ohms
VSWR (Input/Output)	: 1.5: 1 max.
Power Supply	: 110VAC/1.1 Amp : 240VAC/0.55 Amp : 50 to 60 Hz

*\*The Manufacturer's rated output power of this equipment is for single carrier operation. For situations when multiple carrier signals are present, the rating would have to be reduced by 3.5 dB, especially where the output signal is re-radiated and can cause interference to adjacent band users. This power reduction is to be by means of input power or gain reduction and not by an attenuator at the output of the device.*

## **MECHANICAL SPECIFICATIONS:**

Size : 16.0 x 12.0 x 8.75 inch  
(406 x 305 x 222 mm)

Weight : 35 Lbs. (16.0kg.) approx.

## **ENVIRONMENTAL CONDITIONS:**

The unit is designed for outdoor applications:

Operating temperature: - 30°C to + 65°C

Storage temperature: - 50°C to + 90°C

## **BDA CONNECTIONS**

The BDA AC power is accepted through a 3-wire male plug with phase, neutral and ground leads. The AC power is wired to a high efficiency DC switching power supply which is CE and UL approved. The power supply runs the amplifiers and the Power On lamp. The metal enclosure of the BDA is connected to ground.

A 7-pin circular connector provides failure alarm output contacts (see diagrams on page 9) as well as a 12 VDC (250mA) auxiliary output. For OUA option: An AC good alarm and DC good alarm are included. A TTL high is a non-alarm condition and a TTL low is an alarm condition.

For S1 Option: The BDA is equipped with both AC and DC voltage inputs for power operation. This gives the flexibility of powering the BDA with either an AC or DC source. If both sources are connected, the BDA will automatically select the stronger source for power. NOTE: (To insure that the DC source will be selected when both sources are connected, DC input voltage must be at least 27 VDC.)

The RF connections are made via two type "N" female connectors. The RF connector labeled "BASE" must be connected to the antenna pointing towards the base station. The RF connection labeled "MOBILE" must be connected to the antenna facing the area to be covered by the BDA.

The RF connections must be made through cables with characteristic impedance of 50 ohms.

**The isolation between the base station antenna and the mobile antenna should be at least 12 dB higher than the BDA gain. Isolation less than this value can cause gain ripple across the band. Isolation equal to or less than the BDA gain will give rise to oscillations which will saturate the amplifiers and possibly cause damage to the BDA.**

## **OPTIONAL EQUIPMENT OVERVIEW:**

### **a.) Uninterruptible Power System (UPS) Option**

An optional UPS is offered for systems that need emergency back-up power. The system can easily be connected to a battery for uninterruptible operation. Not only does the power supply power the load, but it also charges the battery. If the AC power fails, the battery will uphold the load. In the event that the batteries voltage drops below a safe level, a Low Voltage Battery Disconnect (LVBD) module will disconnect the battery from the load. This will protect the battery from completely discharging and prolong the life of the battery. *Batteries can be supplied upon request or a conventional battery configuration can be used (See Figure 3).*

Two TTL alarms are included: "AC Good" and "DC Power Good". A TTL high is a non-alarm condition and a TTL low is an alarm condition. An optional emergency shut down pin is available.

### **b.) DC Input Power Option (S1)**

The BDA is equipped with both AC and DC voltage inputs for power operation. This gives the flexibility of powering the BDA with either an AC or DC source. If both sources are connected, the BDA will automatically select the stronger source for power.

# Figure 2

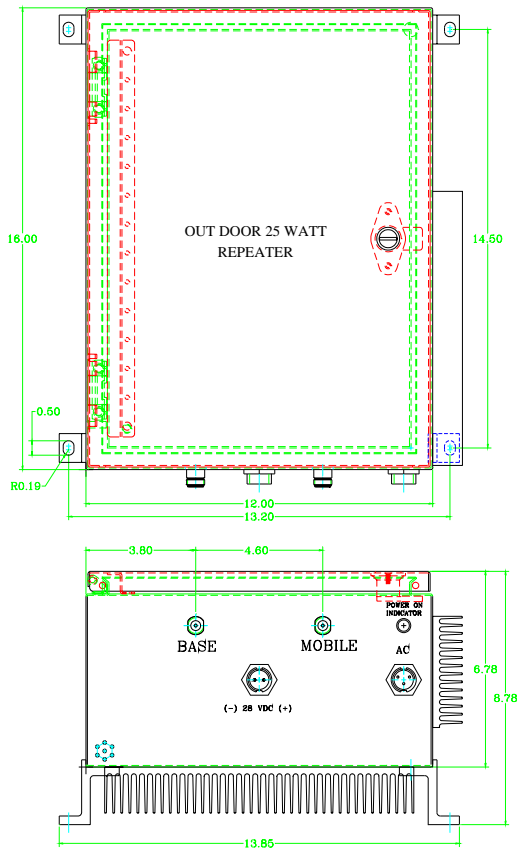

AC Power Supply and DC Source Pinout

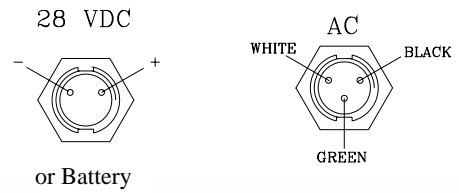

Alarm/Optional Power Supply Pinout  
(Relay States Refer To NON Alarm Condition)

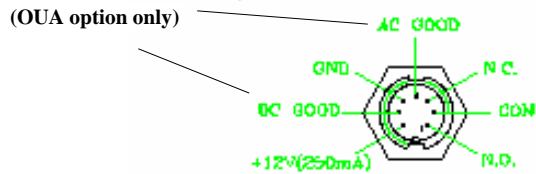

## BDA Mechanical Outline

### Alarm Conditions

The alarm monitors current of both uplink and downlink amplifiers. An alarm condition will occur if either uplink or downlink amplifiers are over or under its current tolerance or if there is no DC power present.

### Figure 2a

(Relay Shown in Non-Alarm Condition)

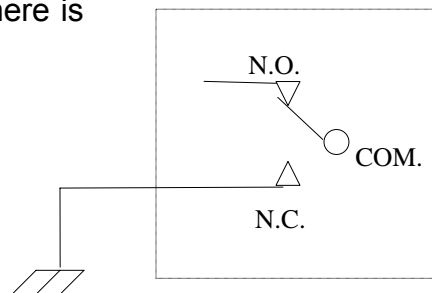



### Figure 3

## Optional Battery Back-Up Configuration

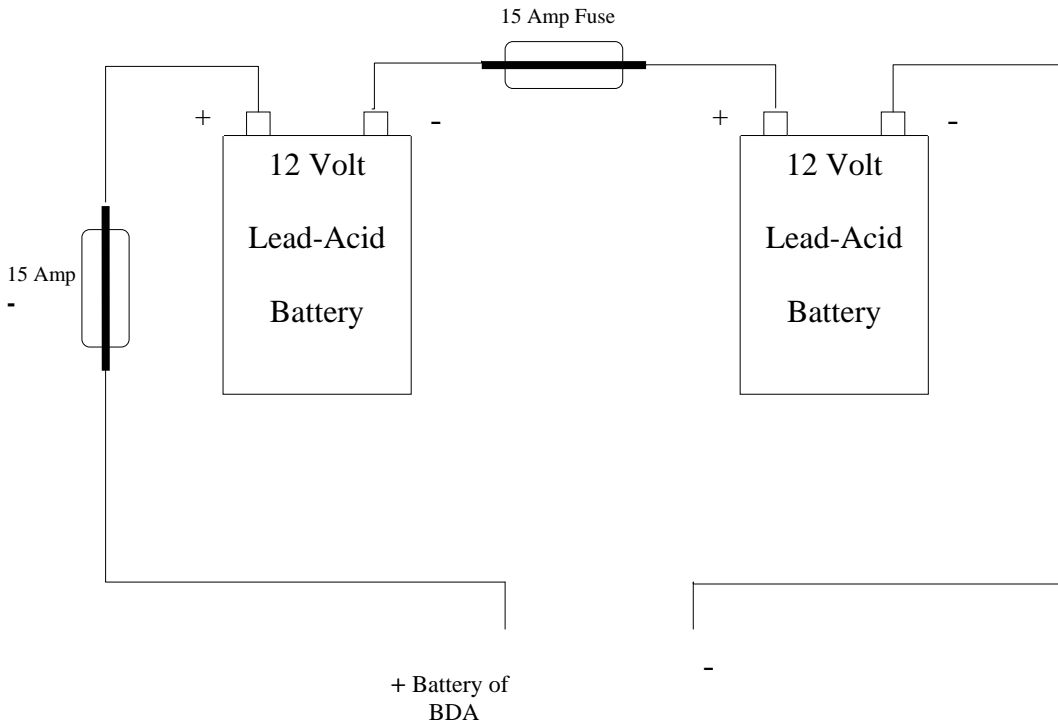

Battery Back-Up Time	Recommend Battery Rated Capacity (20 Hour Rate)	Typical Current Rating for BDA-XXXX-1/25W-88
1 Hour	7.2 Amp Hours	3.5 Amps
2 Hours	12 Amp Hours	3.5 Amps
3 Hours	17 Amp Hours	3.5 Amps
5 Hours	28 Amp Hours	3.5 Amps
7 Hours	42 Amp Hours	3.5 Amps

*Note: We do not guarantee specifications under Battery Back-Up power.*

## **RF EXPOSURE WARNING**

The antenna used for this transmitter must be fixed-mounted on outdoor permanent structures. In order to satisfy the FCC RF exposure requirements, the BDA/antenna installation must comply with the following:

The downlink outdoor antenna (Yagi type or similar directional antenna) must be installed so as to provide a minimum separation distance of 0.35 meters (35 cm) between the antenna and persons within the area. (This assumes a typical antenna with maximum gain of [5 dBi, VSWR  $>?>$  1.5:1,  $Z_o=$  50 ohms, and a cable attenuation of between 1-10 dB)

The uplink outdoor antenna (Yagi type or similar directional antenna) must be installed so as to provide a minimum separation distance of 0.35 meters (35 cm) between the antenna and persons within the area. (This assumes a typical antenna with maximum gain of [15 dBi, VSWR  $>?>$  1.5:1,  $Z_o=$  50 ohms, and a cable attenuation of between 1-10 dB).

## OUTDOOR BDA INSTALLATION PROCEDURE

**IMPORTANT: DO NOT APPLY A.C. OR DC POWER TO THE BDA UNTIL CABLES ARE CONNECTED TO BOTH PORTS OF THE BDA AND THE ANTENNAS.**

1. Mount the BDA on the structure with the RF connectors pointing DOWN. Using appropriate screws and anchors, attach the BDA to the structure using the six mounting holes on the side flanges.
2. Ensure that the isolation between the donor antenna and the service antenna is at least 12 dB greater than the BDA gain. (Use the higher of the Uplink and Downlink gains reported on the BDA test data sheet).
3. Connect the cable from the donor antenna to the BDA connector labeled “BASE” and the cable from the service antennas to the BDA connector labeled “MOBILE”.
4. Open the access door on the BDA and verify that the Uplink and Downlink ALC switches are in their factory preset “ON” positions and attenuation is positioned to its maximum setting.
5. Connect the AC power cord to the BDA and then to the power source. Turn the power switch to its “ON” position. Verify that the “Power On” indicator is lit. Close the access door.

**Installation of the BDA is now complete. To adjust the gain controls to suit the specific signal environment, refer to “Outdoor BDA Operation”.**

***Note: For repeat installations of existing equipment, make sure the ALC switches are in the “ON” position and attenuation is positioned to its maximum setting (30 dB). After verification of ALC switches and attenuation, follow the above steps starting with step 1.***

## **BDA OPERATION**

### **Variable Step Attenuator**

BDA gain can be reduced by up to 30 dB in 2 dB steps using the variable step attenuator (Figure 3). Gain adjustment is made with rotary switches accessible via the access door on the BDA enclosure. Arrows on the shafts of these switches point to the value of attenuation selected. BDA gain can be determined by subtracting the attenuation value from the gain reported on the BDA Test Data Sheet for that side of the unit. The attenuators are labeled for Uplink and Downlink.

### **ALC (Automatic Level Control)**

To minimize intermodulation products, the Uplink amplifier in the BDA contains an ALC feedback loop (Figure 4). The ALC circuit senses the output power and limits it to the factory preset level of +25 dBm on the Uplink and +35 dBm on the Downlink.

ALC function is selected with on/off toggle switches located on each amplifier and accessible when opening the door on the BDA enclosure. A red indicator lamp located on each amplifier illuminates when output power meets or exceeds the ALC set point. The indicator is functional regardless of the position of the ALC switch.

Units are shipped with both ALC switches in the “ON” position. To ensure distortion-free operation limited to the set point, keep the ALC’s turned ON.

To establish proper operating gain on the Uplink and Downlink sides, start with the Uplink. Verify that the ALC switch is in the “ON” position. Observe the red indicator lamp on the Uplink amplifier. Units are shipping with maximum attenuation. Decrease attenuation one step at a time until the lamp is lit. Then, using the Uplink step attenuator, increase the attenuation until the lamp goes off. Repeat the process for the Downlink. The level indicator is accurate to +/- 0.4 dB of the ALC set point.

**Note:** *The recommended operation of the BDA is when the factory set ALC is turned on. Operation of the BDA in the alarm condition will void the warranty, and output power should be immediately reduced using the variable step attenuator.*

**Operation of BDA-SMR-1/25W-90-O at maximum gain with greater than -45 dBm average power incident on the MOBILE port or greater than -35 dBm average power incident on the BASE port can cause damage to the BDA.**

**Figure 4**  
**Variable Gain Adjustment Access**

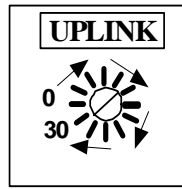
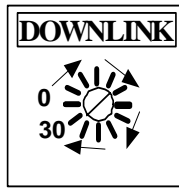

**Down-Link MGC**

**Up-Link MGC**

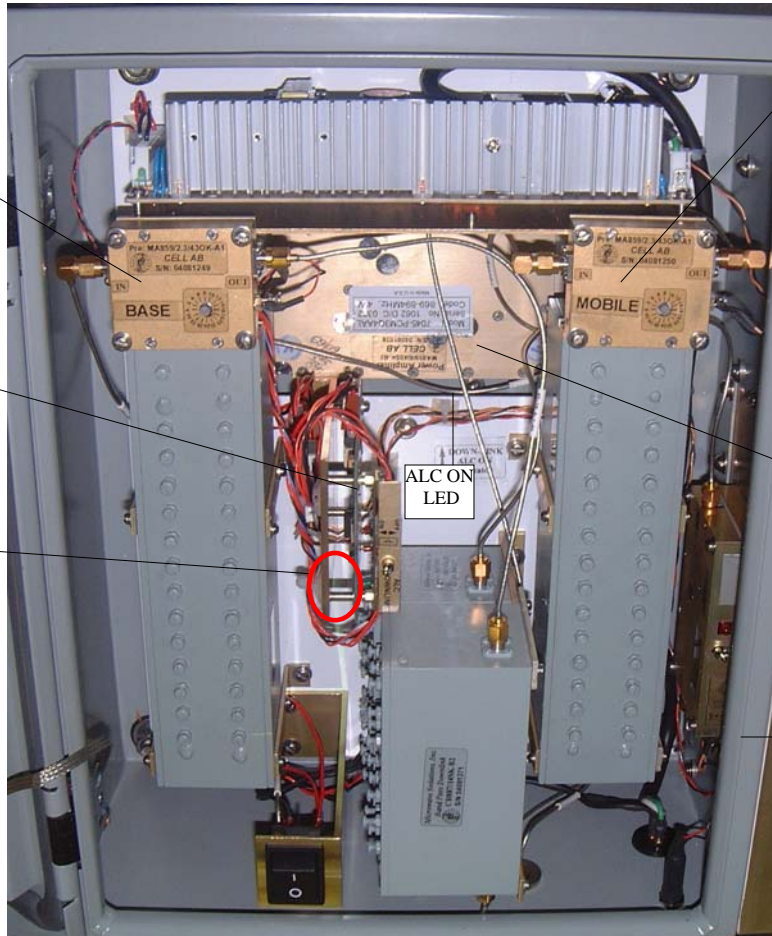

**Alarm Board and  
Down-Link ALC**

**Amplifier Status LEDs**  
Green LED-System OK  
Red LED - Uplink Fail  
Red LED - Downlink Fail

**Down-Link HPA**  
Protected for Temperature  
Protected for Overload

**Up-Link MPA**  
ALC circuit inside

**Figure 5**  
**ALC Adjustment Access**

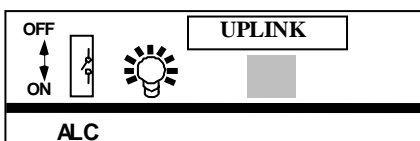

## **DIAGNOSTICS GUIDE**

The BDA provides long term, care-free operation and requires no periodic maintenance. There are no user-serviceable components inside the BDA.

This section covers possible problems that may be related to the installation or operating environment.

### **a. Gain Reduction**

Possible causes: Bad RF cables and RF connections to antennas, Damaged antennas.

### **b. Excessive Intermodulation or Spurious**

Possible causes:

Amplifier oscillation caused by insufficient isolation. The isolation between two antennas is given by the equation:

$$\text{Isolation} = 92.5 + 20 \text{ Log} (F \times D) - G_t - G_r$$

Where:

F = frequency (GHz)

D = separation (Km)

G<sub>t</sub> = transmit antenna gain (in the direction of the receive antenna).

G<sub>r</sub> = receive antenna gain (in the direction of the transmit antenna).

For example, at the SMR frequencies, the antenna isolation at 100 m separation is about 71 dB for omni-directional antennas (0 dB gain). To increase isolation, the antennas should have higher directivity and must be pointed away from each other.

### **c. Occasional Drop-out of some Channels**

Possible causes: One channel with very strong power dominates the RF output of the amplifier.



38 Leuning Street  
South Hackensack, NJ 07606  
Tel. 201-343-3140 Fax 201-343-6390  
[sales@gwaverf.com](mailto:sales@gwaverf.com)  
[www.gwaverf.com](http://www.gwaverf.com)