

Microwave Data Systems

MDS 5800 II Digital Radio Transceiver



User Reference and Installation Manual

June 2005



Table of Contents

1	SAFETY PRECAUTIONS	1-1
	FCC Part 15 Notice	1-2
2	SYSTEM DESCRIPTION	2-1
2.1	About This Manual.....	2-1
2.2	Introduction	2-1
2.3	System Features	2-4
2.4	Physical Description	2-5
2.4.1	Model Types	2-5
2.4.2	Optional Equipment.....	2-6
2.4.3	Front Panel Indicators.....	2-6
2.4.4	Front Panel Connections.....	2-7
2.5	System Description	2-10
2.6	Consecutive Point Architecture.....	2-13
2.7	Network Management.....	2-15
2.8	Power Management.....	2-16
2.9	MDS 5800 II Software and Network Management	2-17
2.10	1+1 Protection	2-17
2.11	2 + 0 (East-West) Configuration.....	2-18
3	INSTALLATION	3-1
3.1	Unpacking	3-1
3.2	Notices.....	3-2
3.3	PRE-INSTALLATION NOTES.....	3-2
3.4	Overview of Installation and Testing Process	3-3
3.5	Site Evaluation	3-4
3.5.1	Preparing for a Site Evaluation.....	3-5
3.5.2	Site Evaluation Process	3-6
3.5.3	Critical System Calculations.....	3-10
3.5.4	Documenting a Site Evaluation	3-14
3.6	Installation of the MDS 5800 II	3-17
3.6.1	Installing the MDS 5800 II Software Defined IDU™	3-17
3.6.2	Installing the MDS 5800 II ODU	3-18
3.6.3	Routing the ODU/ SDIDU™ Interconnect Cable.....	3-20
3.6.4	Grounding the System	3-21
3.6.5	Connecting the SDIDU™ to the PC and Power Source	3-23
3.7	MDS 5800 II Quick Start Guide.....	3-25
3.7.1	Materials Required	3-25
3.7.2	IDU Configuration Process.....	3-25
3.7.3	Connecting the SDIDU™ to the PC and Power Source	3-26
3.7.4	ODU Antenna Alignment	3-30
3.7.5	Documenting MDS 5800 II Configuration	3-31
4	SUMMARY SPECIFICATION	4-1
5	FRONT PANEL CONNECTORS	5-1

5.1	DC Input (Power) Connector	5-1
5.2	Ethernet 100BaseTX Payload Connector 1-2.....	5-1
5.3	SONET Payload Connector	5-2
5.4	STM-1 Payload Connector	5-2
5.5	DS-3/E-3/STS-1 Payload Connector	5-2
5.6	NMS 10/100BaseTX Connector 1-2	5-3
5.7	Alarm/Serial Port Connector.....	5-4
5.8	ODU Connector	5-5
5.9	T1- Channels 1-2 Connector	5-5
5.10	T1- Channels 3-16 Connector	5-6
5.11	USB	5-8
5.12	Voice Order Wire	5-9
5.13	Data Order Wire.....	5-9
6	APPENDIX	6-1
6.1	Abbreviations & Acronyms	6-1

1 Safety Precautions

PLEASE READ THESE SAFETY PRECAUTIONS!

RF Energy Health Hazard



The radio equipment described in this guide uses radio frequency transmitters. Although the power level is low, the concentrated energy from a directional antenna may pose a health hazard. **Do not allow people to come in close proximity to the front of the antenna while the transmitter is operating.** The antenna will be professionally installed on fixed-mounted outdoor permanent structures to provide separation from any other antenna and all persons as detailed on page 1-2.

Protection from Lightning



Article 810 of the US National Electric Department of Energy Handbook 1996 specifies that radio and television lead-in cables must have adequate surge protection at or near the point of entry to the building. The code specifies that any shielded cable from an external antenna must have the shield directly connected to a 10 AWG wire that connects to the building ground electrode.

Proper Disposal

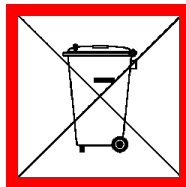

The manufacture of the equipment described herein has required the extraction and use of natural resources. Improper disposal may contaminate the environment and present a health risk due to the release of hazardous substances contained within. To avoid dissemination of these substances into our environment, and to lessen the demand on natural resources, we encourage you to use the appropriate recycling systems for disposal. These systems will reuse or recycle most of the materials found in this equipment in a sound way. Please contact Microwave Data Systems or your supplier for more information on the proper disposal of this equipment.

FCC Notice, USA

Microwave Data Systems Digital Radios comply with Part 15 of the FCC rules. The radios are specifically designed to be used under Part 15, Section 15.247 of the FCC rules and regulations. Operation is subject to following conditions:

- The device to utilize a fixed mount antenna, for use on a permanent outdoor structure.
- The device to be installed by qualified installation/deployment personnel. When the device is operating, a minimum separation must exist between the device and persons as shown in the table below. The following method was used to calculate the RF safety distance:

$$S_{MPE} = PG/4\pi r_{min}^2 = EIRP/4\pi r_{min}^2$$

which is solved for the minimum separation distance

$$r_{min} = (PG/4\pi S_{MPE})^{1/2} = (EIRP/4\pi S_{MPE})^{1/2}$$

where P = power input to the antenna (mW), EIRP = Equivalent (effective) isotropic radiated power, S = maximum permissible exposure (mW/cm²), G = numeric gain of the antenna relative to an isotropic radiator, and r_{min} is the minimum separation distance to the center of radiation (cm). The resulting separation distances are dependent on frequency band.

Frequency Band	Minimum Distance (cm)
UNII Band (nominal frequency = 5.25 GHz)	54
ISM Band (nominal frequency = 5.725 GHz)	285

- The device installers and operators should be aware of the transmitter operating conditions, specified in the installation manual and other associated user documentation, as well as the antenna co-location requirements of Part 1.1307 (b) (3), of FCC rules, pertaining to RF exposure.
- The device may not cause harmful interference.
- The device must accept interference received, including interference that may cause undesired operation.

The device is intended to be used only when installed in accordance with instructions outlined in this manual. Failure to comply with these instructions may void the user's authority to operate this device and/or the manufacturer's warranty. Furthermore, any unauthorized modification or changes to this device without the express approval of Microwave Data Systems may also void the user's authority to operate this device.

FCC Part 15 Notice

This equipment has been tested and found to comply with the limits for a Class A digital device, pursuant to Part 15 of the FCC Rules. These limits are designed to provide reasonable protection against harmful interference when the equipment is operated in a commercial environment. This equipment generates, uses, and can radiate radio frequency energy and, if not installed and used in accordance with the instruction manual, may cause harmful interference to radio communications. Operation of this equipment in a residential area may cause harmful interference, in which case the user will be required to correct the interference at his expense. Any external data or audio connection to this equipment must use shielded cables.

2 System Description

2.1 About This Manual

This manual is written for those who are involved in the “hands-on” installation of the MDS 5800 II Digital Transceiver, such as installation technicians, site evaluators, project managers, and network engineers. It assumes the reader has a basic understanding of how to install hardware, use Windows® based software, and operate test equipment.

The MDS 5800 II includes a Software Defined Indoor Unit™ (SDIDU™) and outdoor unit (ODU). The SDIDU™ is a product and trademark of CarrierComm.

2.2 Introduction

The Microwave Data Systems family of digital radios provides high capacity transmission, flexibility, features, and convenience for wireless digital communications networks. The Microwave Data Systems digital point-to-point radios represent a new microwave architecture that is designed to address universal applications for both PDH and SDH platforms. This advanced technology platform is designed to provide the flexibility to customers for their current and future network needs.

The Microwave Data Systems radio family is based upon a common platform to support a wide range of network interfaces and configurations. It supports links for 16 x E1/T1, 100BaseTX Ethernet, and DS-3/E-3/STS-1 (optional, consult factory for availability). The radio family is spectrum and data rate scalable, enabling service providers or organizations to trade-off system gain with spectral efficiency and channel availability for optimal network connectivity. The Microwave Data Systems digital radio family enables network operators (mobile and private), government and access service providers to offer a portfolio of secure, scalable wireless applications for data, video, and Voice over IP (VoIP).

The MDS 5800 II digital radio family operates in the Industrial, Scientific, and Medical (ISM) band of 5.725 to 5.850 GHz, which is generically referred to as 5.8 GHz, and the Unlicensed National Information Infrastructure (U-NII) band of 5.15 to 5.35 GHz, which is generically referred to as 5.3 GHz. The MDS 5800 II supports three types of user data payload connectivity:

- 100Base-TX intelligent bridging between two locations without the delay and expense of installing cable or traditional microwave.
- Scalable Ethernet capability of 25 and 50 Mbps is included. These scalable radios provide LAN connectivity and offer performance trade-offs between operational bandwidths, data rates, and distance.

- 16E1 or T1 for cellular backhaul, enterprise voice applications and voice network redundancy

For customers such as cellular carriers requiring backhaul and backbone extension as well as service providers requiring network redundancy, new Points of Presence (POPs), and last mile access, the MDS 5800 II radio is a cost effective alternative to leased lines with carrier-class quality of performance. The MDS 5800 II is a cost effective solution to meet the growing demand for enterprise Local Area Network (LAN) connectivity between buildings and campuses as well as service providers requiring reliable products for infrastructure expansion, extending Metropolitan Area Network (MAN) fiber access, and network redundancy.

The MDS 5800 II includes integrated Network Management functionality and design features enabling simple commissioning when the radio network is initially set up in the field at the customer's premises. Furthermore, a highlight of MDS radio products is scalability and the capability to support a ring-type architecture. This ring or consecutive point radio architecture is self-healing in the event of an outage in the link and automatically re-routes data traffic, thereby ensuring that service to the end user is not interrupted.

The MDS 5800 II is composed of a Software Defined Indoor Unit™ (SDIDU™) and Outdoor Unit (ODU). It supports 1+0 and 1+1 protection and ring architectures in a single 1 RU chassis. The modem and power supply functions are supported using easily replaceable plug-in modules. An additional feature of the SDIDU™ is provision for a second plug-in modem/IF module to provide repeater or east/west network configurations.

The overall architecture consists of a single 1RU rack mount Software Defined Indoor Unit (SDIDU™) with a cable connecting to an Outdoor Unit (ODU) with an external antenna.

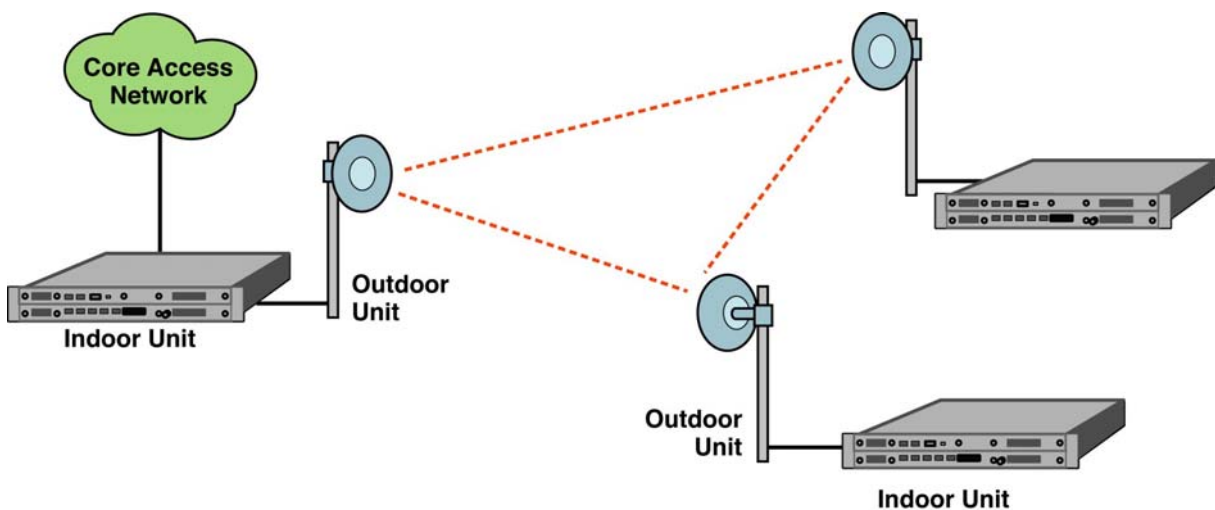

Figure 2-1. MDS 5800 II SDIDU™ /ODU Architecture

Table 2-1 lists key features that MDS 5800 II technology offers to those involved in the design, deployment and support of broadband fixed wireless networks.

Table 2-1 Key Benefits and Advantages of MDS 5800 II Radios

Benefits	Advantages to Providers/Customers	Reference
Wireless license-exempt system		
<p>ISM bands do not require expensive license band fees or incur licensing delays.</p> <p>Wireless connectivity supplements existing cable (Ethernet).</p>	<p>Fast return on investment.</p> <p>Lower total cost of total ownership.</p> <p>Media diversity avoids single points of failure.</p>	2.2 –2.4
Easy to install units		
<p>Straightforward modular system enables fast deployment and activation.</p> <p>Carrier-class reliability.</p>	<p>Fast return on investment.</p> <p>No monthly leased line fees.</p>	3.4
Complete support of payload capacity with additional wayside channels		
<p>Aggregate capacity beyond basic payload (34 Mbps or 50 Mbps or 100 Mbps).</p> <p>Scalable and spectrally efficient system.</p> <p>Separate networks for radio overhead/management and user payload.</p>	<p>Increases available bandwidth of network.</p> <p>Allows customer full use of revenue-generating payload channel.</p> <p>Up to 16 T1/E1 wayside channels supports extension of PBX connectivity between buildings without additional leased-line costs.</p> <p>Lowers total cost of ownership.</p>	2.2– 2.5
Ring Architecture		
<p>Supports a ring (consecutive point) configuration, thus creating a self-healing redundancy that is more reliable than traditional point-to-point networks.</p> <p>In the event of an outage, traffic is automatically rerouted via another part of the ring without service interruption.</p> <p>Ring/consecutive point networks can overcome line-of-sight issues and reach more buildings than other traditional wireless networks.</p> <p>Networks can be expanded by adding more MDS 5800 II units or more rings without interruption of service.</p> <p>A separate management channel allows</p>	<p>Enables network scalability.</p> <p>Increases deployment scenarios for initial deployment as well as network expansion with reduced line-of-sight issues.</p> <p>Increases network reliability due to self-healing redundancy of the network.</p> <p>Minimizes total cost of ownership and maintenance of the network.</p> <p>Allows for mass deployment.</p>	2.4– 2.6, 3.7

Benefits	Advantages to Providers/Customers	Reference
for a dedicated maintenance ring with connections to each MDS 5800 II Digital Radio on the ring.		
Adaptive Power Control		
Automatically adjusts transmit power in discrete increments in response to RF interference.	Enables dense deployment. Simplifies deployment and network management.	2.5,2.7
Comprehensive Link/Network Management Software		
A graphical user interface offers security, configuration, fault, and performance management via standard craft interfaces. Suite of SNMP-compatible network management tools that provide robust local and remote management capabilities.	Simplifies management of radio network and minimizes resources as entire network can be centrally managed out of any location. Simplifies troubleshooting of single radios, links, or entire networks. Simplifies network upgrades with remote software upgrades. Allows for mass deployment.	2.7,2.9,3.7

2.3 System Features

- Selectable Rates and Interfaces
 - Up to 16 x E1/T1 (wayside channels)
 - 100BaseTX/Ethernet: Scalable 5-100 Mbps
 - DS-3/E-3/STS-1 (option; consult factory for availability)
- Support for multiple configurations
 - 1+0, 1+1 protection/diversity
 - Hot Standby
 - East/West Repeater (2 + 0)
- Selectable Spectral Efficiency of 0.8 to 6.25 bits/Hz (including FEC and spectral shaping effects)
- QPSK, 16 – 64 QAM Modulation

- Powerful Trellis Coded Modulation concatenated with Reed-Solomon Error Correction
- Built-in Adaptive Equalizer
- Support of Voice Orderwire Channels
- Peak output power at antenna port
 - 30 dBm at 5.8 GHz
 - 24 dBm at 5.3 GHz
- Receive Sensitivity: -81 dBm to -72 dBm (depending on data rate/modulation/FEC/ODU)
- Adaptive Power Control
- Built-in Network Management System (NMS)
- Consecutive Point ring architecture
- Built-in performance statistics
 - Built-in Bit Error Rate (BER) performance monitoring
- Data encryption of all payload data and T1/E1 wayside channels for MDS 5800 II-100 and MDS 5800 II-50 Ethernet models (Consult factory for availability)

2.4 Physical Description

The following section details the physical features of the MDS 5800 II digital radios

- Model types
- Front and rear panel configurations
- LED descriptions

2.4.1 Model Types

Table 2-2 lists the MDS 5800 II digital radios according to model number and associated capabilities of throughput, data interface, and wayside channel.

Table 2-3 lists the ODU model numbers.

Table 2-2 MDS 5800 II SDIDU™ Model Types

PRODUCT NAME	MODEL NUMBER	FULL DUPLEX THROUGHPUT	DATA INTERFACE	WAYSIDE
MDS 5800 II 50	5800MMVE	100 Mbps Aggregate (50 Mbps full duplex)	100 BaseTX	Two T1/E1s
MDS 5800 II 100	5800MMCE	200 Mbps Aggregate (100 Mbps full duplex)	100 BaseTX	Two T1/E1s
MDS 5800 II 160	5800MMTE	68 Mbps Aggregate (34 Mbps full duplex)	1-16xE1/T1	Scalable Ethernet

Table 2-3 MDS 5800 II ODU Model Types

PRODUCT NAME	MODEL NUMBER	ANTENNA
MDS 5800 II	ODU5800MIDML	Integrated antenna
MDS 5800 II	ODU5800MEDML	External antenna required
MDS 5300 II	ODU5300MIDML	Integrated antenna
MDS 5300 II	ODU5300MEDML	External antenna required

2.4.2 Optional Equipment

The following items are also available:

- AC/DC power supply
- Data Encryption
- Upgrade 50Mbps Ethernet systems to 100Mbps capability

Please consult the factory for more information.

2.4.3 Front Panel Indicators

All models of the MDS 5800 II support a variety of front panel configurations that are dependent on the network interface and capacity configurations.

Figure 2-2 provides an example of the MDS 5800 II-100 1+0 configuration and the associated LEDs displayed on the SDIDU™ front panel.



Figure 2-2. MDS 5800 II LEDs: SDIDU™ Front Panel Configuration for MDS 5800 II, 1+0 Configuration

2.4.4 Front Panel Connections

Please refer to the Figure 2-3 for an example of a MDS 5800 II SDIDU™ front panel followed by a descriptive text of the connections.

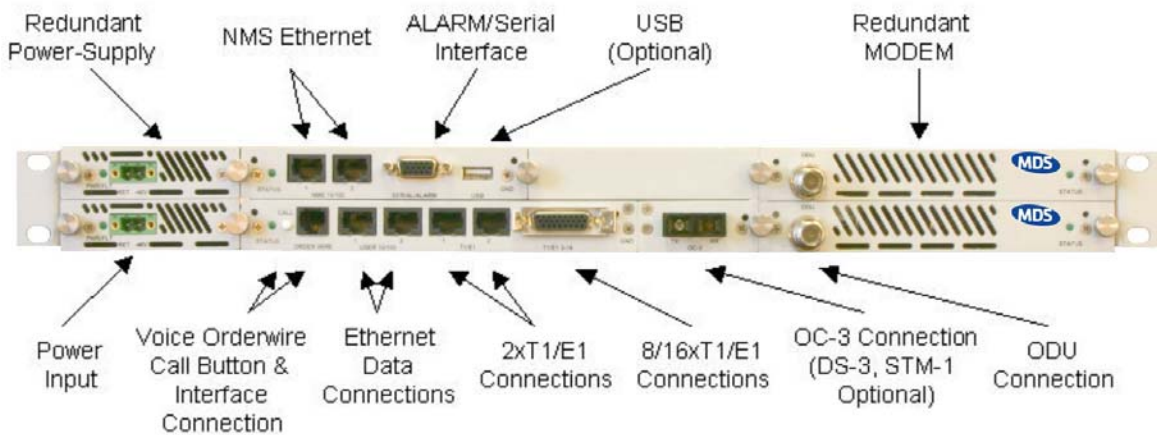

Figure 2-3. MDS 5800 II, 1+1 Protection: SDIDU™ Front Panel Connections

The recommended maximum length for all cables to terminal equipment is a maximum of 3 meters. The exception to this recommendation is the length of the ODU/SDIDU™ Interconnect™ cable, which connects the Outdoor Unit to the Indoor Unit.

Power Supply Input

<p>DC Input</p> <p>-48 VDC</p>	<p>-48v (Isolated Input); 2-pin captive power connector. The MDS 5800 II requires an input of -48 volts dc $\pm 10\%$ at the front panel DC Input connector. The total required power is dependent on the option cards and protection configuration (1+0, 1+1). The SDIDU™ front panel power connector pin numbering is 1 through 2, from left to right, when facing the unit front panel. Pin 1 is the power supply return and is connected to unit chassis ground internally. Pin 2 should be supplied with a nominal -48 V dc, with respect to the unit chassis (ground). A ground-isolated supply may be used, provided it will tolerate grounding of its most positive output.</p> <p>The recommended power input is -44 to -52 V dc at 2 Amps minimum. It is recommended that any power supply used be able to supply a minimum of 100 W to the SDIDU™.</p> <p>A mating power cable connector is supplied with the MDS 5800 II SDIDU™. It is a 2-pin plug, 5 mm pitch, manufactured by Phoenix Contact, P/N 17 86 83 1 (connector type MSTB 2,5/2-STF). This connector has screw clamp terminals that accommodate 24 AWG to 12 AWG wire. The power cable wire should be selected to provide the appropriate current with minimal voltage drop, based on the power supply voltage and length of cable required. The recommended wire size for power cables under 10 feet in length supplying -48 Vdc is 18 AWG.</p> <p>The SDIDU™ supplies the ODU with all required power via the ODU/SDIDU™ Interconnect cable. The MDS 5800 II SDIDU™ does not have a power on/off switch. When DC power is connected to the SDIDU™, the digital radio powers up and is operational. There can be up to 320 mW of RF power present at the antenna port (external antenna version). The antenna should be directed safely when power is applied.</p>
--	--

Alarm/Serial Interface

Alarms/Serial	DB-15HD female connector for two Form-C relay alarm outputs (rated load: 1A @ 24 VDC), two TTL alarm outputs, four TTL alarm inputs, and Serial Console. The two Form-C relay alarm outputs can be configured to emulate TTL alarm outputs.
----------------------	---

USB Interface

USB	USB connector, optional.
------------	--------------------------

Voice Orderwire Connector

Voice Orderwire Call	Call button to alert operator at link-partner SDIDU™ of incoming Voice-Orderwire call.
Voice Orderwire	RJ-11 modular port connector for voice orderwire interface.

NMS 10/100 Network Management System Connections

10/100 LOC	10/100Base-TX RJ-45 modular local port connector for access to the Network Management System (SNMP) and GUI.
10/100 CPT	10/100BaseTX RJ-45 modular remote port connector for access to the Network Management System (SNMP). This port to be used for consecutive point networks.

100/Ethernet Models: Ethernet 100BaseT Connections

100Base-TX LOC	100Base-TX RJ-45 modular port connector for the local Fast Ethernet interface.
100Base-TX CPT	100Base-TX RJ-45 modular port connector. This port to be used for consecutive point networks.

T1 Channels

T1 1-2	Two T1/E1 (RJ-48C) interface connections.
T1 3-16	Fourteen T1/E1 high density interface connector

2.5 System Description

The overall digital radio architecture consists of a single 1RU rack mount Software Defined Indoor Unit™ (SDIDU™) with a cable connecting to an Outdoor Unit (ODU) with an external antenna. The ODU is available with an integrated antenna or connectors to support an external antenna. Two ODU types are available servicing the 5.8 GHz band or the 5.3 GHz band. This SDIDU™/ODU architecture is advantageous when compared to a single IDU with external mount antenna since supporting a signal of 5.8 GHz from the IDU rack to the antenna will result in significant signal degradation, which would require expensive coaxial cable or waveguide.

Figure 2-4 shows the SDIDU™ and interfaces from a functional point of view. The functional partitions for the I/O, Modem/IF, and power supply modules are shown. The SDIDU™ comes with the standard I/O capability that can be upgraded. In addition, the Modem/IF function is modular. This allows the addition of a second Modem to support protection or ring architectures. The power supply is similarly modular.

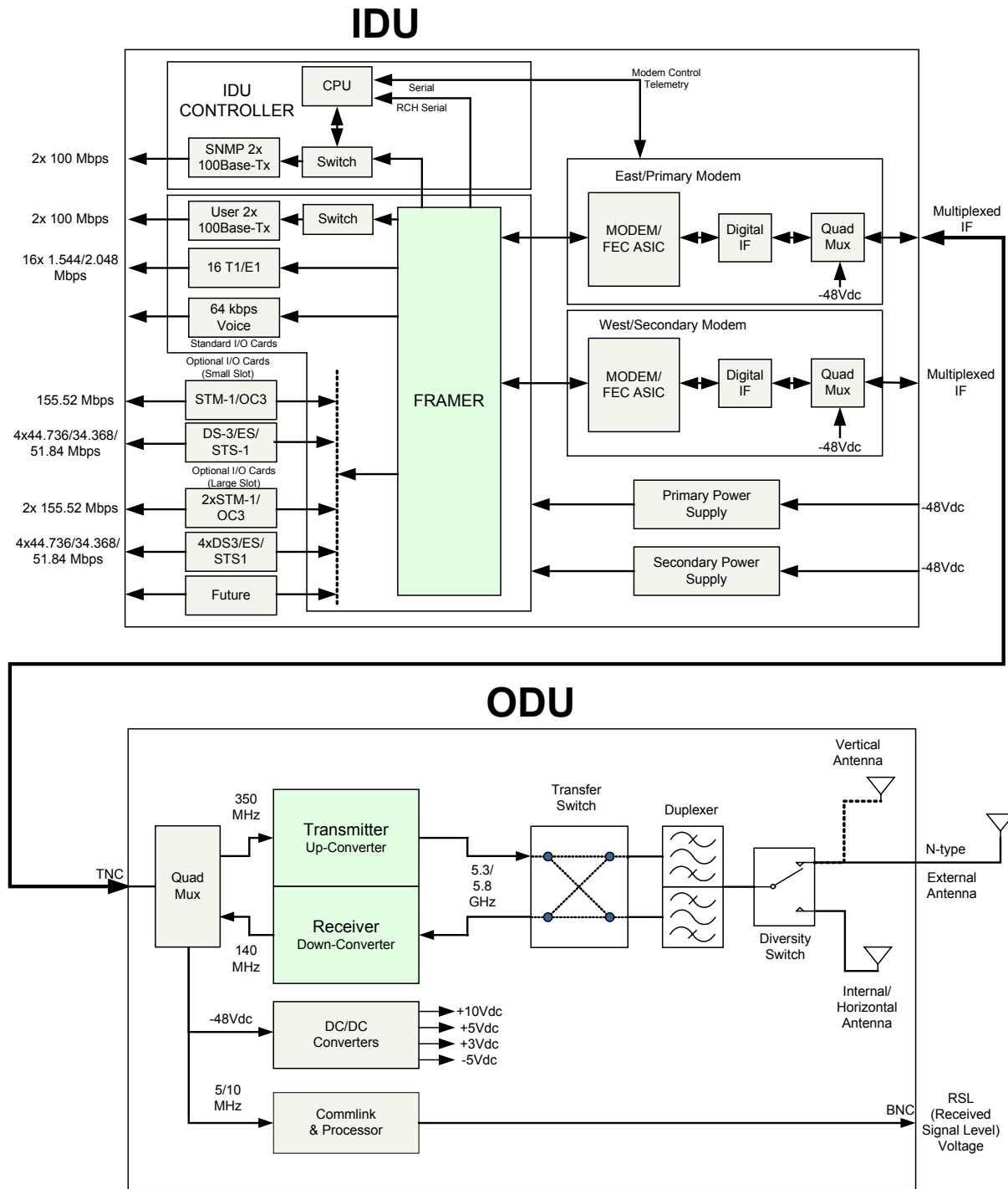

Figure 2-4. MDS 5800 II System Block Diagram

The SDIDU™ interfaces with the ODU to receive and provide modulated transmit and receive waveforms. The SDIDU™ interfaces provide Fast Ethernet 100Base-T (MDS 5800 II-100) connections to the network. Contact factory for availability of SONET OC-3 (MDS 5800 II-155) connections. In addition, one (SONET model) or two (Ethernet model) T1 channels are provided for PBX extension. SNMP is provided on 10/100BaseT ports.

The ODU RF Up/Down Converter card provides the interface to the antenna. The transmit section up converts and amplifies the modulated Intermediate Frequency (IF) of 350 MHz from the IF Processor and provides additional filtering. The receive section down converts the received signal, provides additional filtering, and outputs an IF of 140 MHz to the IF Processor. The 64-QAM Modem performs the modulation and demodulation of the payload and forward error correction using advanced modulation and coding techniques. Using all-digital processing, the 64-QAM Modem uses robust modulation and forward error correction coding to minimize the number of bit errors and optimize the radio and network performance. The 64-QAM Modem also scrambles, descrambles and interleaves/deinterleaves the data stream in accordance with Intelsat standards to ensure modulation efficiency and resilience to sustained burst errors. The modulation will vary by application, data rate, and frequency spectrum. Table 2-4 summarizes the TCM/convolutional code rates for each modulation type supported by the MDS 5800 II.

Table 2-4. MDS 5800 II TCM/Convolutional Code Rates

Modulation Type	Available Code Rates
QPSK	1/2, 3/4, 7/8
16-QAM	3/4, 7/8, 11/12
32-QAM	4/5, 9/10
64-QAM	5/6, 11/12

The major functions of the SDIDU™ can be summarized as follows:

- I/O Processing – The SDIDU™ comes with a standard I/O capability that includes support for up to 16xT1/E1 and 2x100Base-TX user payloads, 2x100Base-TX for SNMP, and voice orderwire. In addition, option cards for DS-3/E3/STS-1, 1-2 x STM-1/OC-3, and 4xDS-3/E3/STS-1 may be added. The SDIDU™ architecture is flexible and allows for the addition of other I/O types in the future.
- Switch/Framing – The SDIDU™ includes an Ethernet Switch and a proprietary Framer that are designed to support 1+1 protection switching, ring architecture routing, and overall network control functions.
- Network Processor – The SDIDU™ includes a Network Processor that performs SNMP and Network Management functions.
- Modem/IF – The SDIDUTM Modem performs forward-error-correction (FEC) encoding, PSK/QAM modulation and demodulation, equalization, and FEC decoding functions. The IF chain provides a 350 MHz carrier, receives 140 a MHz carrier, processes OOK telemetry, and provides –48V power. Two modems can be used for 1+1 protection or ring architectures.
- Power Supply – The SDIDU™ power supply accepts -48 Vdc and supplies the SDIDU™ and ODU with power. A second redundant power supply may be added as an optional module.

The Modem Processor and its associated RAM, ROM, and peripherals control the digital and analog Modem operation. It also provides configuration and control for both the IF and I/O cards. The SDIDU™ interfaces with the ODU to receive and provide modulated transmit and receive waveforms.

The 64-QAM Modem performs the modulation and demodulation of the payload/wayside/SNMP data and forward error correction using advanced modulation and coding techniques. Using all-digital processing, the 64-QAM Modem uses robust modulation and forward error correction coding to minimize the number of bit errors and optimize the radio and network performance. The 64-QAM Modem also scrambles, descrambles and interleaves/deinterleaves the data stream in accordance with Intelsat standards to ensure modulation efficiency and resilience to sustained burst errors. The modulation will vary by application, data rate, and frequency spectrum. The highest order modulation mode supported is 64 Quadrature Amplitude Modulation (QAM).

The SDIDU™ also provides the physical interface for the user payload and network management. In transmit mode, the Frammer merges user payload with radio overhead-encapsulated network management data. This combined data stream is transmitted without any loss of user bandwidth. In the receive mode, the Frammer separates the combined data stream received from the 64-QAM Modem. The SDIDU™ supports Scalable Ethernet data rates, such as 25 or 50 Mbps via the 100BaseT data interface port. The SDIDU™ provides network management data on 10 Mbps ports accessible via the 10/100BaseTX port. The Central Processor Unit (CPU) provides the embedded control and network element functionality of the OAM&P. The CPU also communicates with other functions within the SDIDU™ for configuration, control, and status monitoring. The CPU passes appropriate status information to the SDIDU™ front panel display.

In Ethernet models, the payload of each user Ethernet data packet and all T1 can be encrypted using an AES encryption algorithm. In addition, the encryption engine is re-seeded with a new, randomly generated key stream every 10 seconds, in order to provide enhanced security. The initial key is based off of a pass phrase entered into each MDS 5800 II unit by the network administrator. Consult factory for the availability of this encryption function.

The power supply converts -48 Vdc to the DC voltage levels required by each component in the system.

2.6 Consecutive Point Architecture

The consecutive point network architecture is based upon the proven SONET/SDH ring. Telecommunications service providers traditionally use the SONET/SDH ring architecture to implement their access networks. A typical SONET/SDH network consists of the service provider's Point of Presence (POP) site and several customer sites with fiber optic cables connecting these sites in a ring configuration (see Figure 2-5). This architecture lets providers deliver high bandwidth with high availability to their customers.

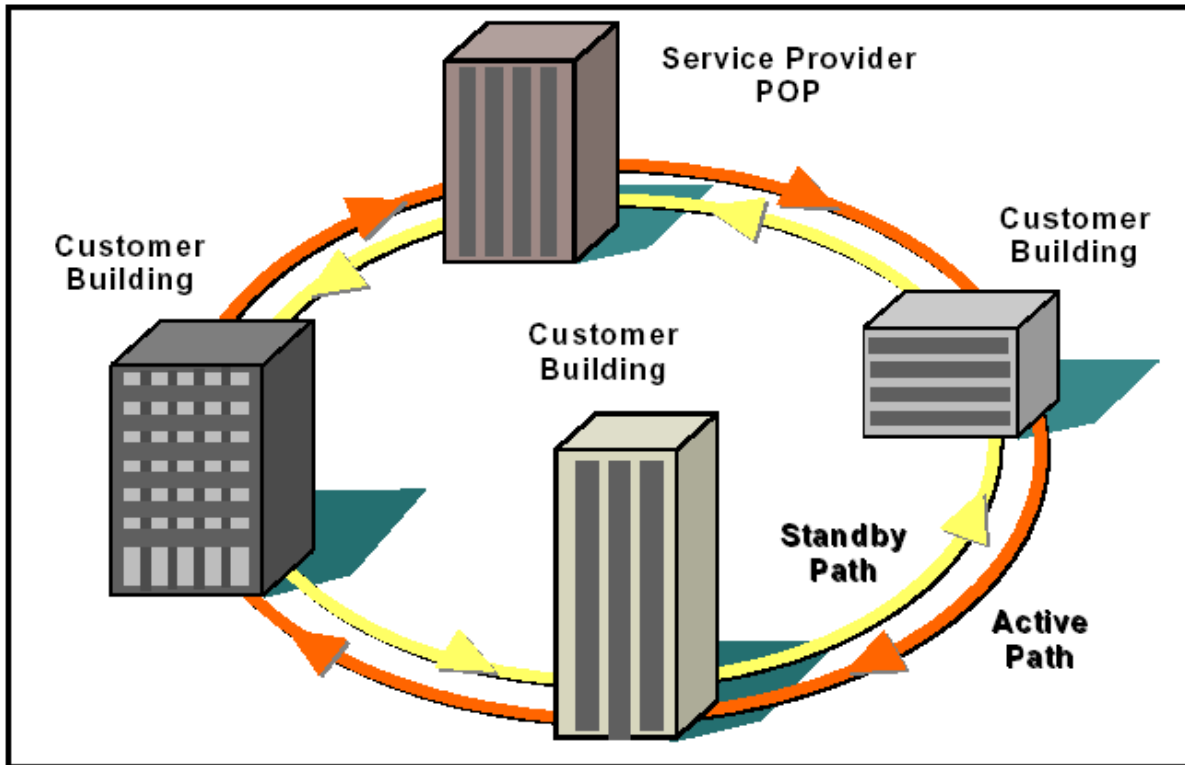

Figure 2-5. Ring Configuration.

SONET/SDH rings are inherently self-healing. Each ring has both an active path and a standby path. Network traffic normally uses the active path. Should one section of the ring fail, the network will switch to the standby path. Switchover occurs in seconds. There may be a brief delay in service, but no loss of payload, thus maintaining high levels of network availability.

The consecutive point architecture implemented in the MDS 5800 II Digital Radio family is based on a point-to-point-to-point topology that mimics fiber rings, with broadband wireless links replacing in-ground fiber cable. A typical consecutive point network consists of a POP and several customer sites connected using MDS 5800 II units. These units are typically in a building in an east/west configuration. Using east/west configurations, each unit installed at a customer site is logically connected to two other units via an over-the-air radio frequency (RF) link to a unit at an adjacent site.

Each consecutive point network typically starts and ends at a POP. A pattern of wireless links and in-building connections is repeated at each site until all buildings in the network are connected in a ring as shown in Figure 2-6.

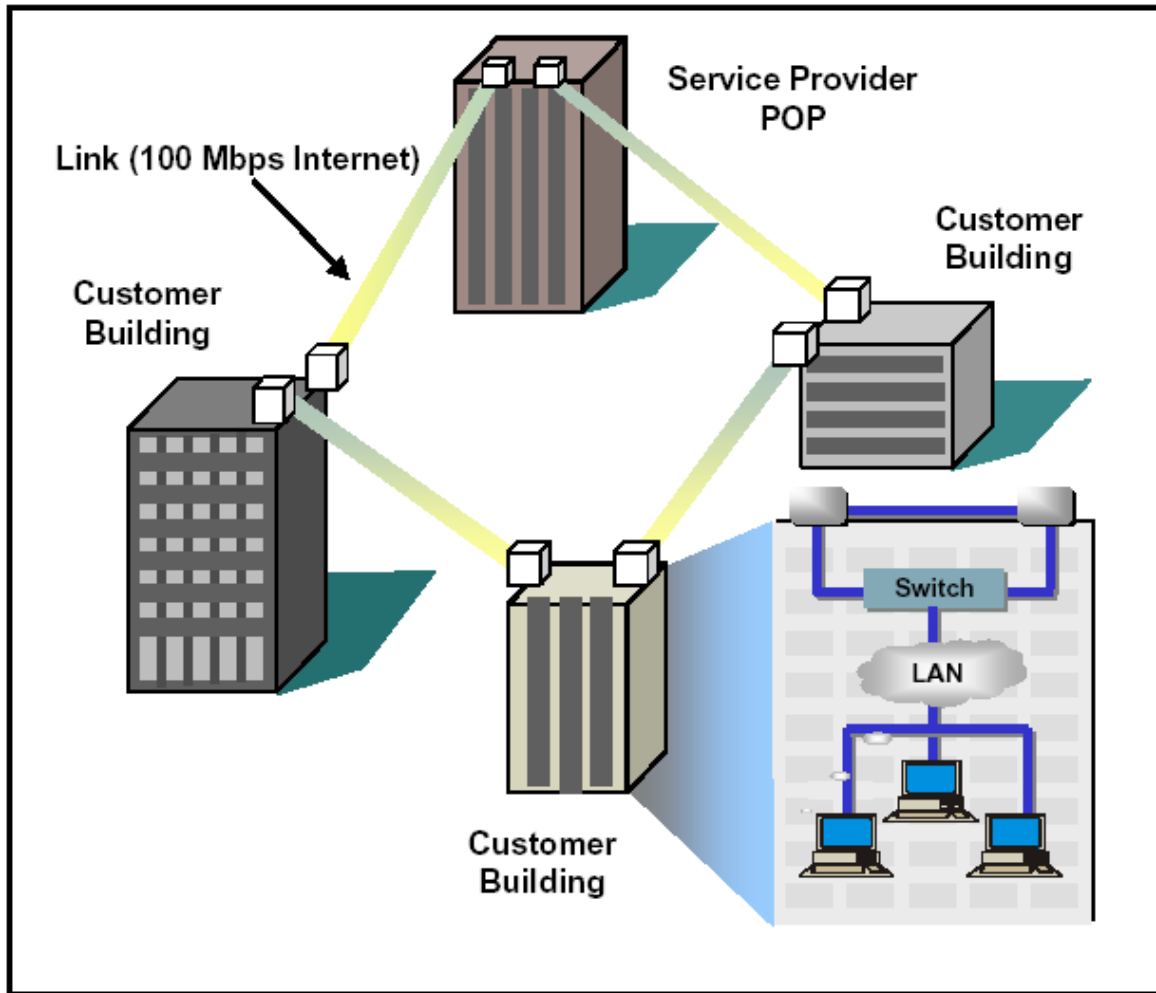

Figure 2-6. Consecutive Point Network

2.7 Network Management

All of the MDS 5800 II parameters are accessible in three ways:

1. Using a standard web-browser via HTTP to access the built in webserver.
2. Via SNMP using the fully featured MIB, allowing for automation of data collection and network management.
3. Via a command line client accessible from a terminal client connected to the serial port, or telnet over the NMS Ethernet.

Control of the MDS 5800 II is supported as follows:

- Network Management options described in Section 2.9.

2.8 Power Management

RF power management is a radio design feature that controls the power level (typically expressed in dBm) of the RF signal received from a transmitter by a receiver. The traditional goal of power management is to ensure that the RF signal at a receiver is strong enough to maintain the radio link under changing weather and link conditions.

Traditional power management techniques such as Constant Transmit Power Control (CTPC) and Automatic Transmit Power Control (ATPC) transmit at a high power level to overcome the effects of fading and interference. However, these techniques continue to operate at a higher power level than needed to maintain the link in clear weather. Because transmit power remains high when the weather clears, the level of *system interference* increases.

Radios operating at high transmit power will interfere with other radios, even if the interfering source is miles away from the victim. High interference levels can degrade signal quality to the point that wireless radio links become unreliable and network availability suffers. The traditional solution to system interference is to increase the distance between radios. However, the resulting sparse deployment model is inappropriate for metropolitan areas.

In response to the need for a high-density deployment model the MDS 5800 II use a unique power control technique called A_dTPC. A_dTPC enables MDS 5800 II units to transmit at the minimum power level necessary to maintain a link regardless of the prevailing weather and interference conditions. The MDS 5800 II is designed and manufactured to not exceed the +30 dBm maximum power allowed. The purpose of power management is to minimize transmit power level when lower power levels are sufficient. A_dTPC also extends the concept of power management by controlling not only the power (dBm) of the RF signal, but its quality (signal-to-noise ratio) as well.

In contrast to ATPC, the A_dTPC technique dynamically adjusts the output power based on both the actual strength and quality of the signal. Networked MDS 5800 II units constantly monitor receive power and maintain 10^{-12} BER performance under varying interference and climate conditions. Each MDS 5800 II unit can detect when there is a degradation in the received signal level of quality and adjust the transmit power level of the far-end MDS 5800 II unit to correct for it.

A_dTPC provides maximum power in periods of heavy interference and fading and minimum power when conditions are clear. Minimal transmit power reduces potential for co-channel and adjacent channel interference with other RF devices in the service area, thereby ensuring maximum frequency re-use. The resulting benefit is that operators are able to deploy more MDS 5800 II units in a smaller area.

2.9 MDS 5800 II Software and Network Management

All of the MDS 5800 II parameters are accessible through a Graphical User Interface (GUI) installed on every SDIDU™. To access this the SDIDU™ needs to be connected to a computer with a web browser installed. Directing the browser to the IP address of the SDIDU™ will start the GUI. More information about the GUI is available in the User Interface Manual.

2.10 1+1 Protection

The MDS 5800 II supports 1+1 protection as an option for a critical link. In this configuration, protection is provided in a single 1 RU chassis. The SDIDU™ contains two power supplies and two modems. One modem is referred to as the west modem and the other as the east modem. 1+1 protection can be run in two modes called diversity and non-diversity. In diversity mode, the link between each pair of modems is the same, as shown in Figure 2-7, providing complete redundancy. This arrangement requires bandwidth for both links and non-interference between the links, but it provides hitless receive and transmit switching.

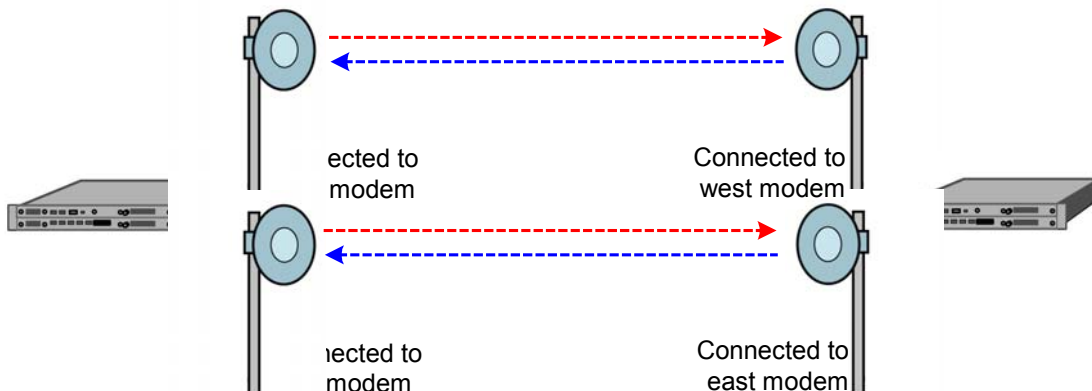

Figure 2-7. 1+1 protection in diversity mode

Figure 2-8 shows operation in non-diversity mode. In this mode, one ODU at each location transmits to both two ODUs at the other location. This mode does not require the extra bandwidth or interference protection of diversity mode. It provides hitless receive switching and hot standby. The SDIDU™ automatically switches transmit ODU upon appropriate ODU alarm or ODU interface error, minimizing transmit outage time.

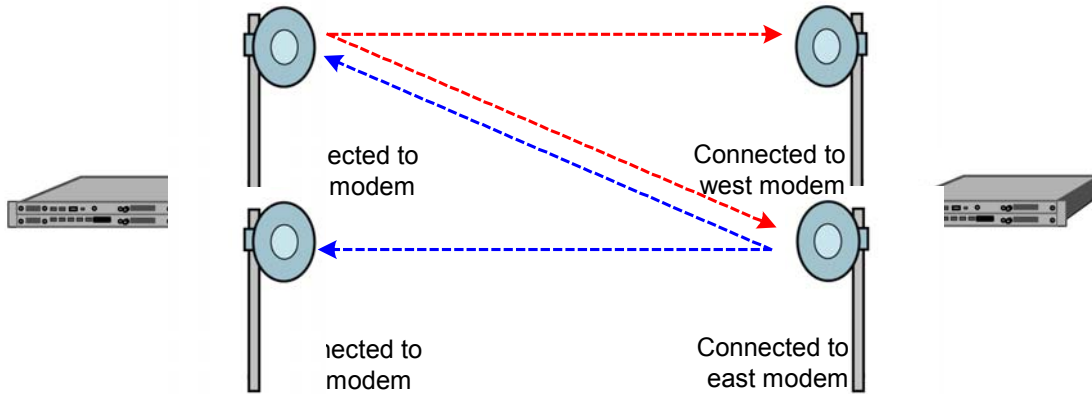
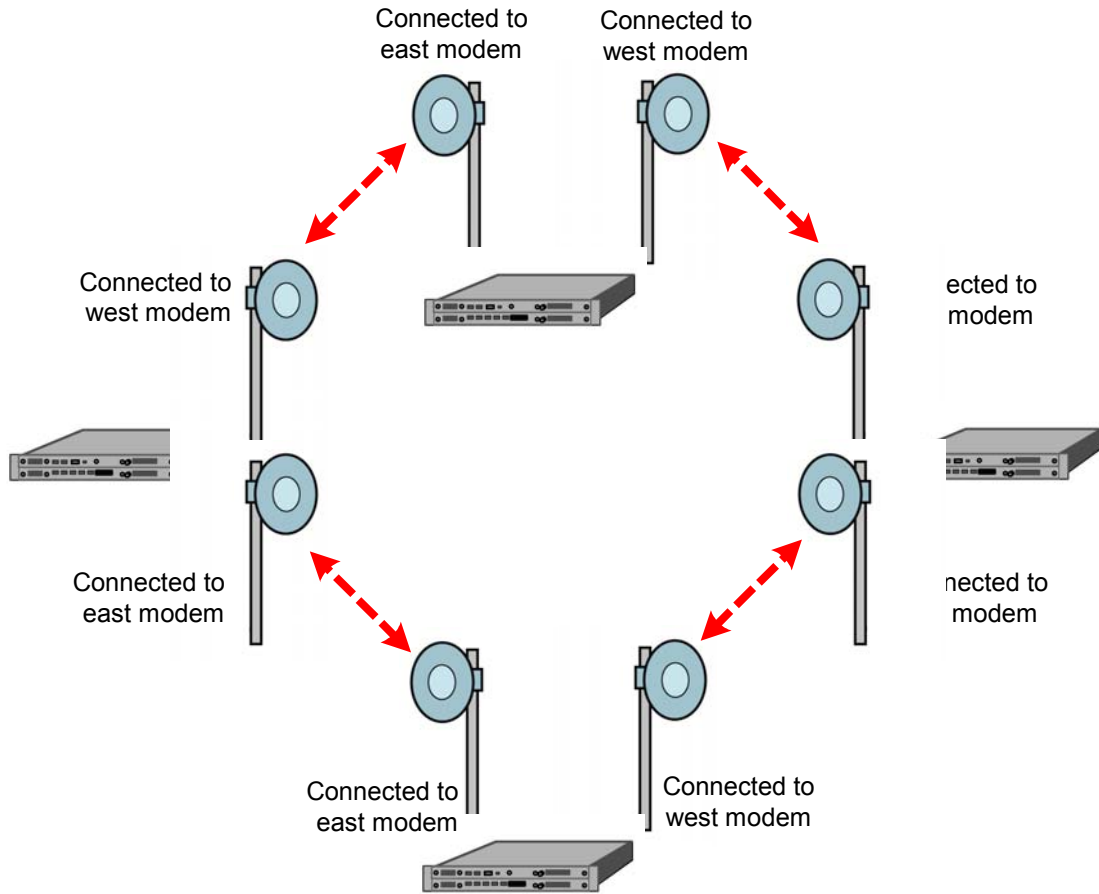

Figure 2-8. 1+1 protection in non-diversity mode

2.11 2 + 0 (East-West) Configuration

The MDS 5800 II supports a 2+0, or east-west, configuration that allows a consecutive point architecture to be achieved with only a single 1 RU chassis at each location. In this configuration the SDIDU™ contains two power supplies and two modems. One modem is referred to as the west modem and the other as the east modem. The SDIDU™ is connected to two ODUs, one broadcasting/receiving in one directing of the ring architecture and the other broadcasting/receiving in the other as shown in



3 Installation

3.1 Unpacking

The following is a list of possible included items.

Description	Quantity
Digital Radio SDIDU™ (1RU chassis)	1
ODU (with hardware)	1
Manual (or Soft copy on a CD)	1

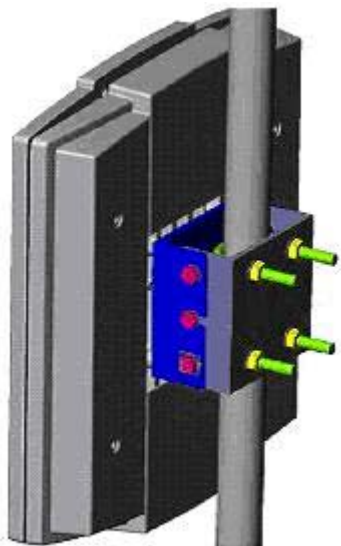

ODU



SDIDU™

Figure 3-1. MDS 5800 II Components

Be sure to retain the original boxes and packing material in case of return shipping. Inspect all items for damage and/or loose parts. Contact the shipping company immediately if anything appears damaged. If any of the listed parts are missing, call the distributor or the factory immediately to resolve the problem.

3.2 Notices

CAUTION

DO NOT OPERATE EXTERNAL ANTENNA ODU UNITS WITHOUT AN ANTENNA, ATTENUATOR, OR LOAD CONNECTED TO THE ANTENNA PORT. DAMAGE MAY OCCUR TO THE TRANSMITTER DUE TO EXCESSIVE REFLECTED RF ENERGY.

ALWAYS ATTENUATE THE SIGNAL INTO THE RECEIVER ANTENNA PORT TO LESS THAN -20 dBm. THIS WILL PREVENT OVERLOAD AND POSSIBLE DAMAGE TO THE RECEIVER MODULE.

WARNING

HIGH VOLTAGE IS PRESENT INSIDE THE ODU and SDIDU™ WHEN THE UNIT IS PLUGGED IN. TO PREVENT ELECTRICAL SHOCK, UNPLUG THE POWER CABLE BEFORE SERVICING. UNIT SHOULD BE SERVICED BY QUALIFIED PERSONNEL ONLY.

3.3 PRE-INSTALLATION NOTES

It may be useful to gain familiarity with the MDS 5800 II via back-to-back bench testing prior to final installation. We highly recommend installation of lightning protectors on the ODU/IDU Interconnect Cable to prevent line surges from damaging expensive components.

Back-to-back bench testing prior to final installation is highly recommended in order to gain familiarity with the product. The following additional equipment is required for back-to-back testing:

- Low-loss cables, N-male connectors on ODU interfaces.
- Four Inline RF attenuators, 40 dB each (or replace two with single 80 dB attenuator), rated for ODU frequency.

The SDIDU™ and ODUs must be configured in an operational configuration and set-up as shown in Figure 3-2. When equipment is connected in operational configuration, no errors should be reported on the front panel.

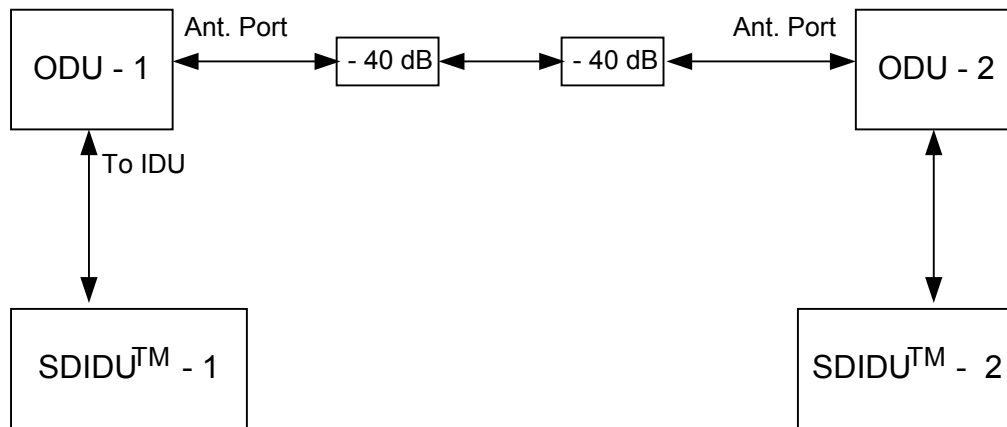

Figure 3-2. MDS 5800 II Back-to-Back Testing Configuration

3.4 Overview of Installation and Testing Process

The installation and testing process is accomplished by performing a series of separate, yet interrelated, procedures, each of which is required for the successful implementation of a production MDS 5800 II network. These procedures are as follows:

- Site Evaluation: gathering specific information about potential MDS 5800 II installation sites.
- Cable and Installation: Testing and installing MDS 5800 II ODU cables and optional interface devices at installation sites.
- MDS 5800 II ODU Mounting and Alignment: Mounting ODUs to a pole or wall, performing link alignment and radio frequency (RF) verification.
- MDS 5800 II Digital Radio Configuration: Using MDS 5800 II Link Manager software to install network- and site-specific parameters in the radios.
- MDS 5800 II Digital Radio Testing: Performing cable continuity checks and RF tests for links, the payload/radio overhead channel, and the management channel.

The following diagram shows where installation and commissioning resides within the MDS 5800 II network deployment life cycle and defines the sequence in which the processes that comprise installation and commissioning should be performed.

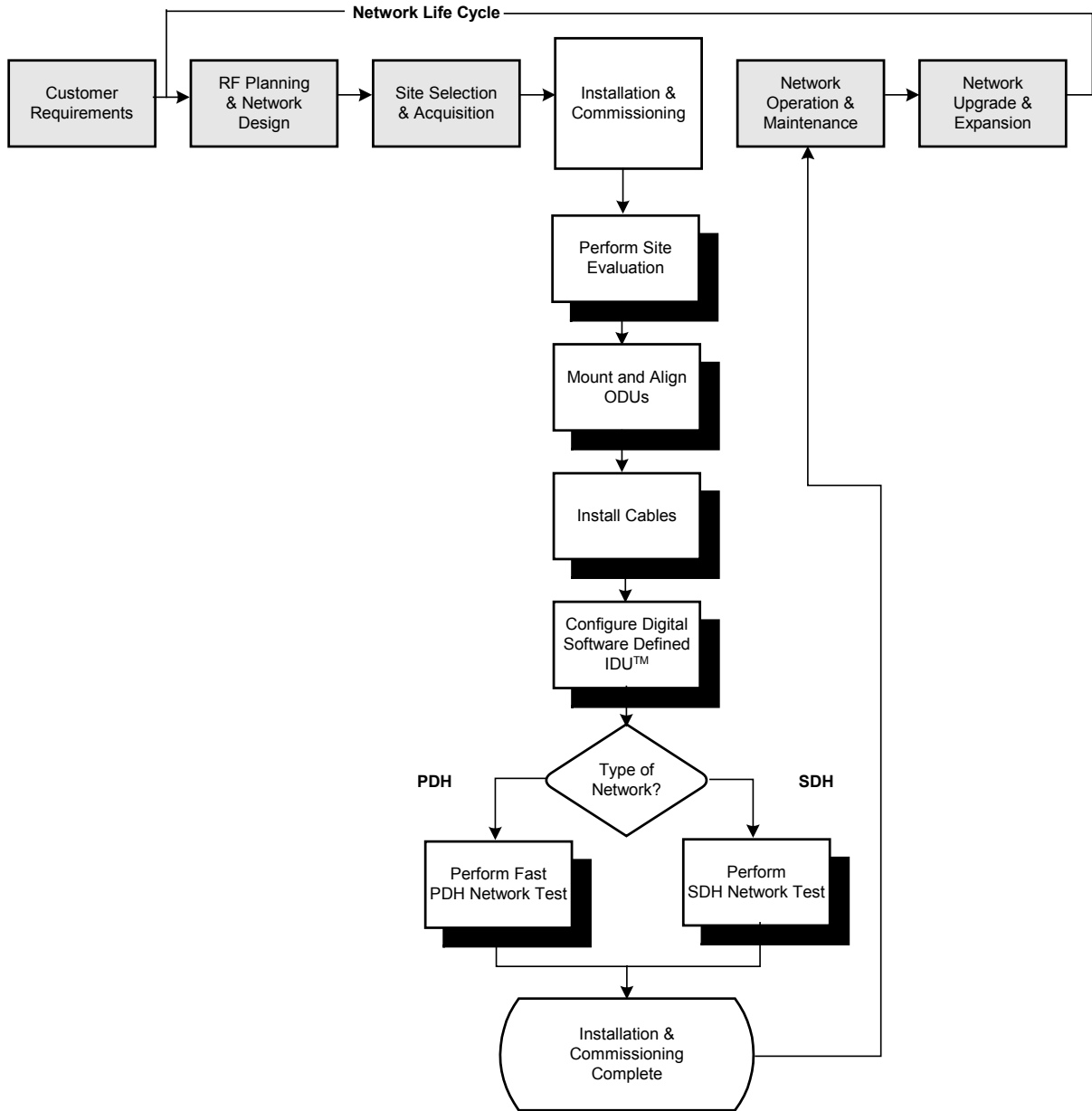

3.5 Site Evaluation

A site evaluation consists of a series of procedures for gathering specific information about potential MDS 5800 II locations. This information is critical to the successful design and deployment of a network.

Site evaluations are required to confirm whether or not a building meets network design requirements. The main objectives are as follows:

- Confirm
 - Line of sight for each link
 - MDS 5800 II ODU mounting locations
 - Site equipment locations
 - Cable routes
 - Any other potential RF sources
- Prepare site drawings and record site information

3.5.1 Preparing for a Site Evaluation

The following tools are required to perform a site evaluation:

- RF and network design diagrams (as required)
- Binoculars
- Global positioning system (GPS) or range finder
- Compass
- Measuring tape and/or wheel
- Digital camera
- Area map
- Aerial photograph (if available)
- List of potential installation sites (“targeted buildings”)

The following tasks must be completed prior to performing a site evaluation:

- Prepare the initial network design by performing the following:
 - Identify potential buildings by identifying targeted customers (applicable if you’re a service provider)
 - Identify potential links by selecting buildings based on the high probability of line of sight
- Arrange for access with the facility personnel into the buildings, equipment rooms, and architectural plans to become familiar with the location of all ducts, risers, etc.

3.5.2 Site Evaluation Process

The following steps must be completed to perform a successful site evaluation. Each step in the process is detailed in the following subparagraphs:

- **Ensure RF Safety compliance:** Ensure that appropriate warning signs are properly placed and posted at the equipment site or access entry. For a complete list of warnings, refer the Safety Precautions listed at the beginning of this manual.
- **Ensure Compliance with Laws, Regulations, Codes, and Agreements:** Ensure that any installation performed as a result of the site evaluation is in full compliance with applicable federal and local laws, regulations, electrical codes, building codes, and fire codes.
- **Establish Radio Line of Sight between MDS 5800 II Radios:** **The most critical step in conducting a site evaluation is confirming a clear visual and radio Line of Sight (LOS) between a near MDS 5800 II Radio and a far MDS 5800 II Radio. If LOS does not exist, another location must be used.**

MDS 5800 II Radios in a link must have a clear view of each other, or visual "line of sight". Binoculars may be used evaluate the path from the desired location of the near MDS 5800 II Radio to the desired location of the far MDS 5800 II Radio.

To confirm Line of Sight:

- Ensure that no obstructions are close to the transmitting/receiving path. Take into consideration trees, bridges, construction of new buildings, unexpected aerial traffic, window washing units, etc.
- Ensure that each MDS 5800 II can be mounted in the position required to correctly align the MDS 5800 II with its link partner.

MDS 5800 II Radios must also have a clear radio line of sight. If a hard object, such as a mountain ridge or building, is too close to the signal path, it can damage the radio signal or reduce its strength. This happens even though the obstacle does not obscure the direct, visual line of sight. The Fresnel zone for a radio beam is an elliptical area immediately surrounding the visual path. It varies in thickness depending on the length of the signal path and the frequency of the signal. The necessary clearance for the Fresnel zone can be calculated, and it must be taken into account when designing a wireless links.

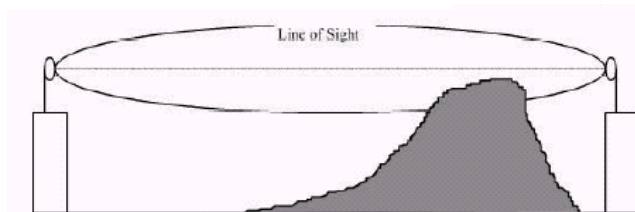

As shown in the picture above, when a hard object protrudes into the signal path within the Fresnel zone, knife-edge diffraction can deflect part of the signal and cause it to reach the receiving antenna slightly later than the direct signal. Since these deflected signals are out of phase with the direct signal, they can reduce its power or cancel it out altogether. If trees or other 'soft' objects protrude into the Fresnel zone, they can

attenuate (reduced the strength of) a passing signal. In short, the fact that you can see a location does not mean that you can establish a quality radio link to that location. Microwave Data Systems provides a link planner spreadsheet that calculates the Fresnel ratio and helps determine link feasibility. Contact your technical support representative for a copy of the spreadsheet.

- Determine MDS 5800 II ODU Mounting Requirements: MDS 5800 II ODUs can be mounted on an antenna mast, brick, masonry or wall. Refer to detailed installation sections.
- Determine MDS 5800 II SDIDU™ Installation Location: MDS 5800 II SDIDUs™ can be installed tabletop or cabinet, wall mount, or rack mount. The site must provide DC power or an optional AC/DC converter may be used. Refer to detailed installation sections.
- Document Potential Sources of Co-location Interference: When MDS 5800 II ODUs are located on a roof or pole with other transmitters and receivers, an interference analysis may be required to determine and resolve potential interference issues. The interference analysis needs to be performed by an RF engineer. The specific information required for each transmitter and receiver includes the following:
 - Transmitting and/or receiving frequency
 - Type of antenna
 - Distance from MDS 5800 II ODU (horizontal and vertical)
 - Polarity (horizontal or vertical)
 - Transmit power level
 - Antenna direction
- Measure the Link Distance: The two ways to measure link distance are as follows:
 - GPS: record the latitude and longitude for the near and far MDS 5800 II ODU sites and calculate the link distance. Record the mapping datum used by the GPS unit and ensure the same mapping datum is used for all site evaluations in a given network.
 - Range finder: measure the link distance (imperial or metric units may be used).

Once the link distance has been measured, verify that the link distance meets the availability requirements of the link. Microwave Data Systems has created a spreadsheet tool that calculates the link availability based on the details of the link. The Microsoft Excel spreadsheet is available on the software distribution CD and is shown on the following page. The following parameters should be entered (items in yellow):

- Operating Frequency: Enter 5800 or 5300
- Transmit Antenna Gain: Enter 23 for the internal antenna or enter the gain of the external antenna if used.
- Transmit Output Power: Selectable between -8 to – +23dB (5.8 GHz) and –18 to +13 (5.3 GHz) in 1 dB steps.

- Receive Antenna Gain: Enter 23 for the internal antenna or enter the gain of the external antenna if used.
- Link Distance: Enter distance in miles or kilometers (must select the correct units: miles or kilometers)
- Fresnel Clearance Ratio: This is a factor indicating the radio line of sight. A clear radio line of site has a fresnel clearance ratio of +0.60. As the curvature of the earth or other obstacles degrade the radio line of sight, the ratio can drop to -1. A separate spreadsheet is provided to calculate the appropriate ratio. In this spreadsheet the path length, tower heights and heights of any obstructions or ridges in the path of the link are entered.
- Climate Factor: Enter 0.1 for dry, 0.25 for average and 0.5 for humid environments
- Terrain Factor: Enter 0.25 for mountainous, 1 for average, and 4 for smooth (water)
- Determine the Length of Interconnect Cable from ODU to SDIDU™: The primary consideration for the outdoor interconnect cable from the ODU to SDIDU™ is the distance and route between the ODU and SDIDU™. This cable should not exceed 330 feet using Times Microwave LMR-200 cable. Longer lengths and distances are possible, but require higher quality cable.
- ODU/IDU Cable Length: Enter the cable length in feet between the ODU and IDU. Maximum cable lengths are listed in Table 3-1.

Table 3-1. Maximum cable lengths

Cable Type	Loss at (dB/100 m)		Maximum Length*
	140 MHz	350 MHz	
LMR-200	12.6	20.1	100 m
LMR-300	7.6	12.1	165 m
LMR-400	4.9	7.8	256 m
RG-214	8	13.1	153 m
Belden 7808	8.6	14	143 m

* Does not account for connector loss.

The link availability, dispersive fade margin and expected signal strength readings are calculated based on the entered parameters. Maximum link distances based on the antenna and transmitter power settings are also displayed.

Path Length (Km)	15
TX Tower Height (m)	30
RX Tower Height (m)	20
Frequency (MHz)	5800
Calculated Fresnel Clearance Ratio	0.05

MDS 5800 II Link Planner: Fresnel Zone Clearance

Distance from TX (Km)	Optical LOS Height (m)	1st Fresnel Zone Radius (m)	1st Fresnel Zone Height (m)	Radio LOS (60% Fresnel Clearance) Zone Height (m)	Earth Curvature ¹ (m)	Obstruction Height (m)	Total Earth Terrain Height (m)	Fresnel Clearance Ratio
0.0	30.0	0.0	30.0	30.0	0.0	0.0	0.0	-
0.4	29.8	4.3	25.4	27.1	0.3	0.0	0.3	6.77
0.8	29.5	6.1	23.4	25.9	0.6	0.0	0.6	4.76
1.1	29.3	7.3	21.9	24.9	0.9	0.0	0.9	3.87
1.5	29.0	8.3	20.7	24.0	1.2	0.0	1.2	3.33
1.9	28.8	9.2	19.5	23.2	1.4	0.0	1.4	2.97
2.3	28.5	9.9	18.6	22.5	1.7	0.0	1.7	2.70
2.6	28.3	10.6	17.7	21.9	1.9	20.0	21.9	0.60
3.0	28.0	11.1	16.9	21.3	2.1	10.0	12.1	1.43
3.4	27.8	11.6	16.1	20.8	2.3	10.0	12.3	1.33
3.8	27.5	12.0	15.5	20.3	2.5	23.0	25.5	0.17
4.1	27.3	12.4	14.8	19.8	2.6	24.0	26.6	0.05
4.5	27.0	12.7	14.3	19.4	2.8	0.0	2.8	1.90
4.9	26.8	13.0	13.7	18.9	2.9	0.0	2.9	1.83
5.3	26.5	13.3	13.2	18.5	3.0	0.0	3.0	1.77
5.6	26.3	13.5	12.8	18.2	3.1	0.0	3.1	1.72
6.0	26.0	13.6	12.4	17.8	3.2	5.0	8.2	1.31
6.4	25.8	13.8	12.0	17.5	3.2	0.0	3.2	1.64
6.8	25.5	13.8	11.7	17.2	3.3	0.0	3.3	1.61
7.1	25.3	13.9	11.4	16.9	3.3	0.0	3.3	1.58
7.5	25.0	13.9	11.1	16.7	3.3	0.0	3.3	1.56
7.9	24.8	13.9	10.9	16.4	3.3	0.0	3.3	1.54
8.3	24.5	13.8	10.7	16.2	3.3	0.0	3.3	1.53
8.6	24.3	13.8	10.5	16.0	3.2	0.0	3.2	1.53
9.0	24.0	13.6	10.4	15.8	3.2	0.0	3.2	1.53
9.4	23.8	13.5	10.3	15.7	3.1	0.0	3.1	1.53
9.8	23.5	13.3	10.2	15.5	3.0	7.0	10.0	1.02
10.1	23.3	13.0	10.2	15.4	2.9	0.0	2.9	1.56
10.5	23.0	12.7	10.3	15.4	2.8	0.0	2.8	1.59
10.9	22.8	12.4	10.3	15.3	2.6	0.0	2.6	1.62
11.3	22.5	12.0	10.5	15.3	2.5	0.0	2.5	1.66
11.6	22.3	11.6	10.6	15.3	2.3	0.0	2.3	1.72
12.0	22.0	11.1	10.9	15.3	2.1	0.0	2.1	1.79
12.4	21.8	10.6	11.2	15.4	1.9	0.0	1.9	1.88
12.8	21.5	9.9	11.6	15.5	1.7	0.0	1.7	1.99
13.1	21.3	9.2	12.0	15.7	1.4	0.0	1.4	2.15
13.5	21.0	8.3	12.7	16.0	1.2	0.0	1.2	2.37
13.9	20.8	7.3	13.4	16.4	0.9	0.0	0.9	2.71
14.3	20.5	6.1	14.4	16.9	0.6	0.0	0.6	3.28
14.6	20.3	4.3	15.9	17.6	0.3	0.0	0.3	4.59
15.0	20.0	0.0	20.0	20.0	0.0	0.0	0.0	-

Note1: Earth Curvature is based on a spherical Earth model with a nominal radius of 6371Km and a typical K-factor of 1.33.

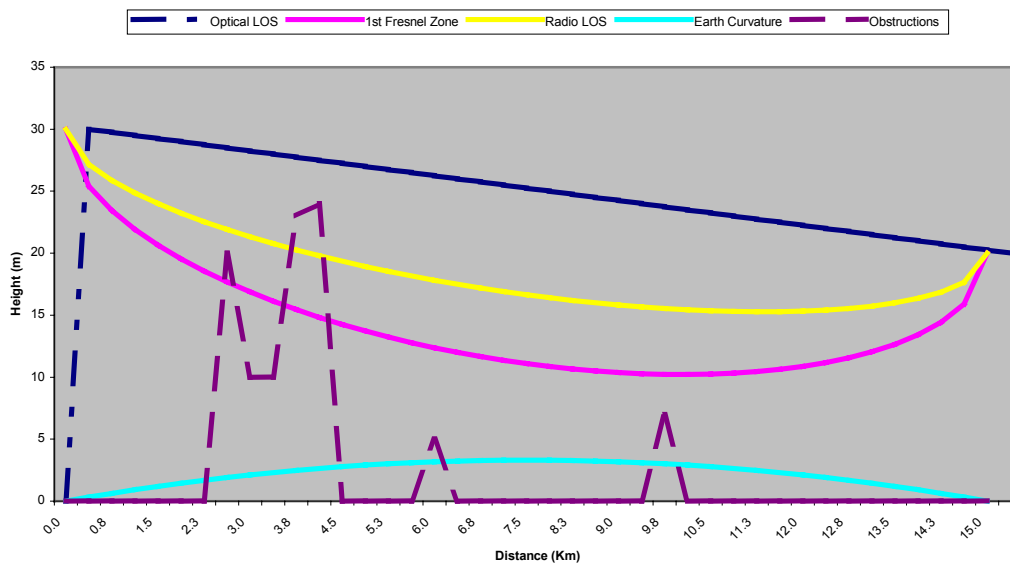

- Select the Grounding Location for both the MDS 5800 II ODU and SDIDU™. The MDS 5800 II must be properly grounded in order to protect it and the structure it is installed on from lightning damage. This requires
 - Grounding all ODUs as specified by supplier
 - Grounding all SDIDU™ to the rack.
- Confirm the Presence of DC Power for the MDS 5800 II SDIDU™.
- Ensure Building Aesthetics: Ensure that the ODU can be mounted so that it is aesthetically pleasing to the environment and to the property owner. Aesthetics must be approved by the property owner and the network engineer.
- Take Site Photographs
- Sketch the Site

3.5.3 Critical System Calculations

3.5.3.1 Received Signal Level (RSL) and Link Budget

The received signal level (RSL) can be estimated using the following formula:

$$\text{RSL (dBm)} = P_{\text{TX}} + G_{\text{TX ANT}} - L_{\text{Path}} + G_{\text{RX ANT}}$$

Where: P_{TX} is the transmitter output power (in dBm)

$G_{\text{TX ANT}}$ is the gain of the transmit antenna (in dB), 23 dBi for ODU's internal antenna

$G_{\text{RX ANT}}$ is the gain of the receive antenna (in dB), 23 dBi for ODU's internal antenna

L_{Path} is the Path loss, defined by:

$$L_{\text{P}} \text{ (dB)} = 36.6 + 20\log_{10}(F \cdot D)$$

Where: F is the Frequency in MHz (5800 or 5300), D is the Distance of path in miles

This link budget is very important in determining any potential problems during installation. The expected RSL and measured RSL should be close (+/- 5 to 10 dB)

3.5.3.2 Fade Margin Calculation

The fade margin is the difference between the actual received signal and the MDS 5800 II Radio's threshold for the modulation mode selected. The fade margin can be used to determine availability and should be at least 10 dB.

3.5.3.3 Availability Calculation

Availability of the microwave path is a prediction of the percent of time that the link will operate without producing an excessive BER due to multipath fading. Availability is affected by the following:

- Path length
- Fade margin
- Frequency
- Terrain (smooth, average, mountainous, valleys)
- Climate (dry, temperate, hot, humid)

Depending on the type of traffic carried over the link and the overall network design redundancy, fade margin should be included to support the desired availability rate. Critical data and voice may require a very high availability rate (99.999% or 5.3 minutes of predicted outage per year). To improve availability, the fade margin can be increased by shortening the path length, transmitting at a higher power level, or by using higher gain antennas.

Availability can be computed using the following formula, which is known as the *Vigants Barnett Method*.

$$\text{Availability} = 100 \times (1 - P)$$

$$P = 2.5 \times 10^{-9} \times C \times F \times D^3 \times 10^{(-FM/10)}$$

Where F is the frequency in MHz (5300 or 5800)

D is the distance in miles

FM is the fade margin in dB

C is the climate/terrain factor as defined below:

Humid/Over Water: C = 4 (worst case channel)

Average Conditions: C = 1

Dry/Mountains: C = 0.25 (best case channel)

Example: Assume 21 dB fade margin, over 5 miles with average climate/terrain, at 5.8 GHz. The availability comes out to be 99.9986. This corresponds to the link being unavailable for 7.6 minutes per year.

3.5.3.4 Frequency Plan Determination

When configuring MDS 5800 II units in a point-to-point or consecutive point configuration, careful engineering of the MDS 5800 II frequency plans and antenna locations should be performed in order to minimize potential interference between nearby radios. Nearby radios should operate on different frequencies, transmitting in the same band (high side or low side). When designing multi-radio configurations, antenna size, antenna polarization, and antenna location are critical.

The frequency plan must be selected based on desired data rate and expected link conditions. In a high interference environment or with lower gain antennas, higher bandwidth, more robust modulation formats must be employed. The available frequency plans are illustrated in Figure 3-3 and Figure 3-4.

Additional frequency plans are available for co-existence with other 5.8GHz equipment or for backhaul purposes. These plans use the frequencies at the ends of the ISM band and provide a contiguous available frequency space in the center of the band for other equipment. The backhaul frequency plans are illustrated in Figure 3-5.

The channel assignments shown in the figures correspond to the channel numbers entered via the graphical user interface (GUI) or SNMP.

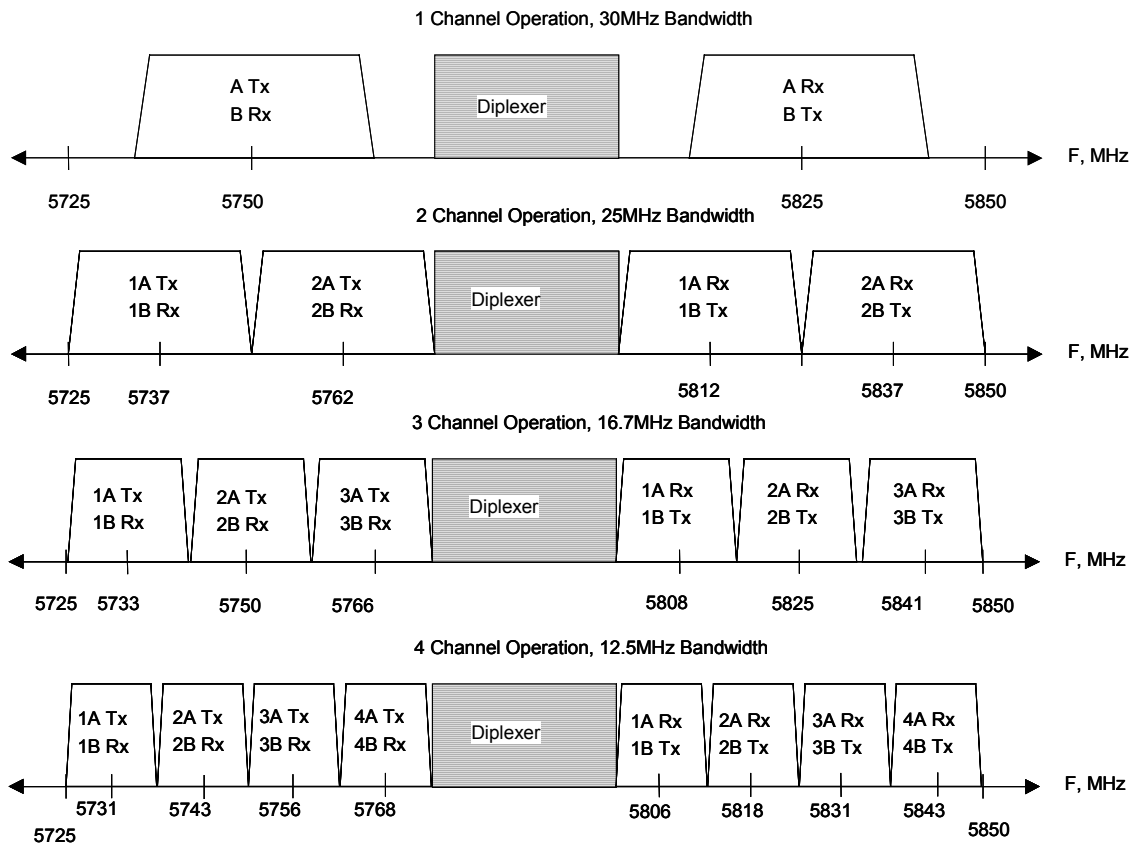

Figure 3-3. MDS 5800 II Channel 5.8 GHz Frequency Plan

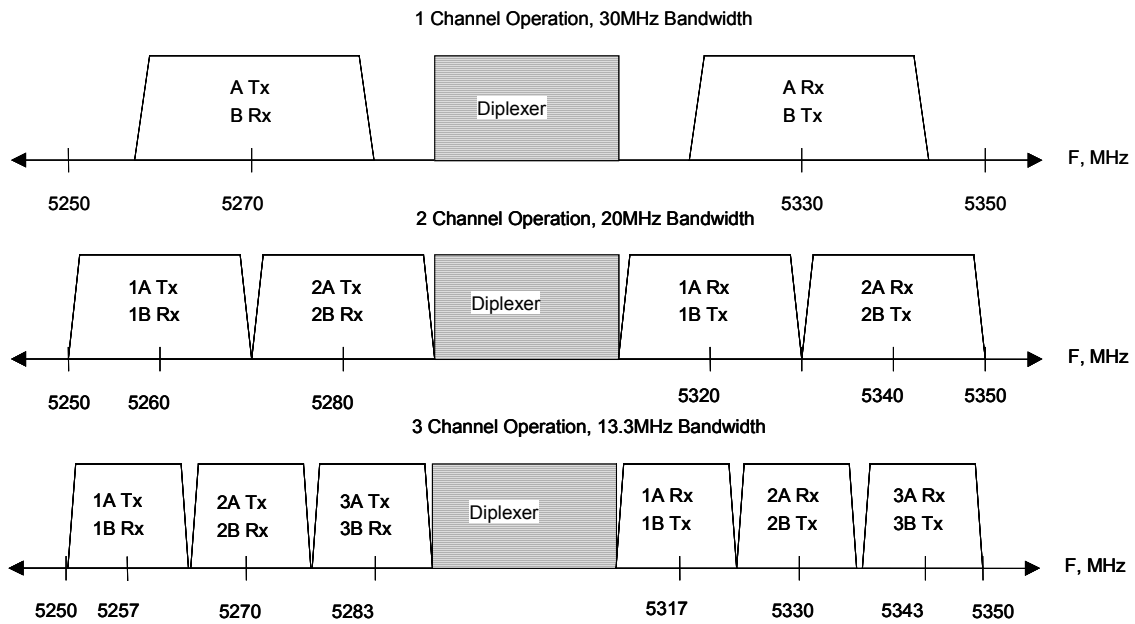

Figure 3-4. MDS 5800 II Channel 5.3 GHz Frequency Plan

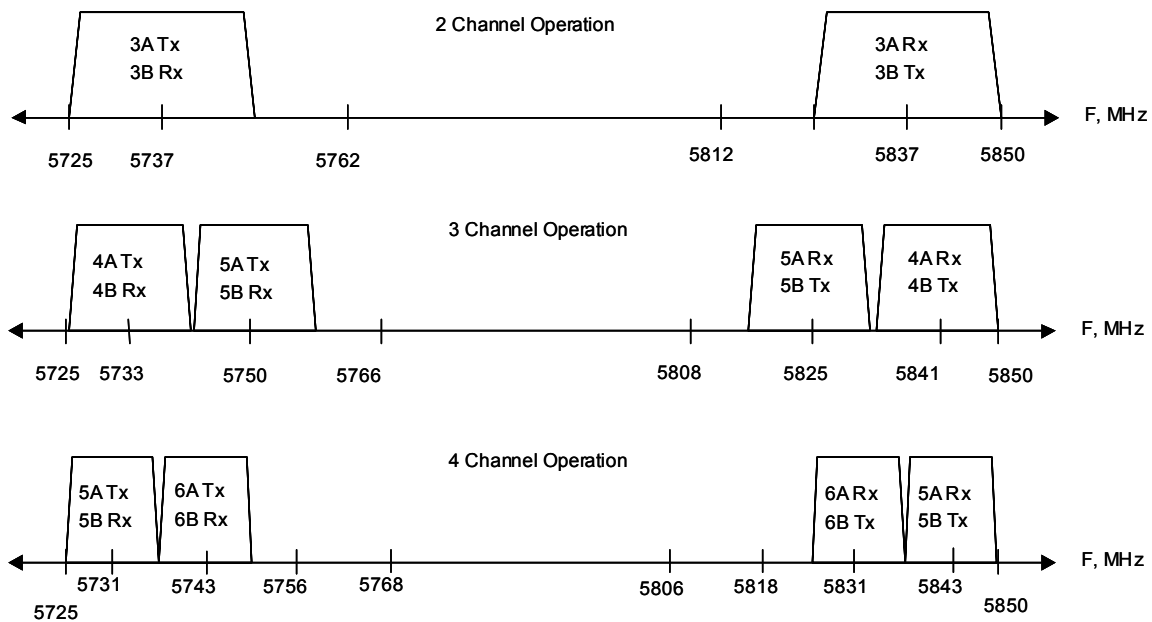

Figure 3-5. MDS 5800 II Backhaul Frequency Plans

3.5.3.5 Antenna Planning

The ODU comes with a built in 23 dBi gain antenna. This should provide adequate link performance for most applications.

Larger antennas have the advantage of providing narrower beamwidths and high isotropic gain, which yields better link performance (higher fade margin, better availability), and improves immunity to spatial interference (due to the smaller beamwidths). However, larger antennas are more costly to purchase and install than smaller antennas and in some cases, they require special equipment for installation due to narrower beamwidths. They are also more easily affected by wind.

Only directional antennas can be used with MDS 5800 II radios. Consult factory for antenna manufacturer options.

The ISM band does not restrict antenna gain or EIRP, therefore there is no need to back off transmit power due to excessive antenna gain.

1. Select where the cable will enter the building from the outside.
2. Determine the length of cable required. Allow three extra feet on each end to allow for strain relief, as well as any bends and turns.

3.5.4 Documenting a Site Evaluation

Use the site evaluation form provided on the following pages to document the results of your site evaluation. Optimally, this complete site form would be stored with the IDU for future reference.

Site Evaluation Form					
Address				Site Engineer	
				Contact Person	
				Phone	
Site No			Site Agent		
Site Type					
ODU Roof Location					
ODU	#	Latitude	Longitude	Mapping Datum (ex. NDA27)	
Roof Requirements	Example	Information	Information	Information	
	ODU#	4			
	Clear Line of Sight	Yes			
	Mounting Method	Wall or Pole			
	FCC Compliance	Yes			
	Collocation				
	Aesthetics				
	ODU Azimuth	60 degrees			
	GPS Reading	80 21' 48"			
	Cable Lengths				
	Alarm				
	Interconnect Cable	250 feet			
	Grounding/Lighting				
	Instructions				
	Photographs*				
Photo 1					
Photo 2					
Photo 3					
Sketches**					
Sketch 1					
Sketch 2					
Recommendations for Site Photographs and Sketches					
*Photographs			**Sketches		
Photo 1 - ODU mounting location			Sketch 1- Roof and cable route to entry point		
Photo 2 - View from the ODU mounting location to the link partner			Sketch 2 - Details for grounding and lighting protection		
Photo 3 - IDU location			Sketch 3 - IDU room and cable routes from entry port		

Site Evaluation

	Parameters	Example Information	Information	Information	Information
Colocated	Source	PCS			
	Tx and/or Rx	Tx/Rx			
	Frequency	2.1 GHz			
	Distance from ODU	5 feet			
	Owner	Sprint PCS			
	Azimuth	210 degrees			
	Elevation	2 degrees downtilt			
	Antenna Type				
	Power				
	Power	14W			

	Parameters	Example Information	Information	Information	Information
SDIDU™	IDU room Identified	Yes			
	Space for cabinet	Yes			
	Phone line	Need to install			
	48 VDC available?	Yes			
	Cables	Confirm cables			
	Take Photo 3				
	Sketch 3				

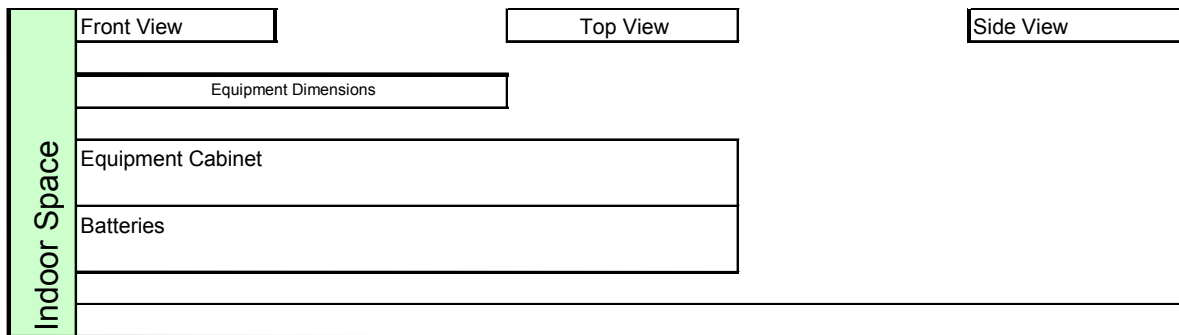

Note	

3.6 Installation of the MDS 5800 II

The following sections provide installation guides for:

- SDIDU™ Installation
- ODU Installation

3.6.1 Installing the MDS 5800 II Software Defined IDU™

The MDS 5800 II SDIDU™ can be installed in the following three options:

1. Table top or cabinet
2. Wall mount
3. Rack mount

The MDS 5800 II SDIDU™ should be:

- Located where you can easily connect to a power supply and any other equipment used in your network, such as a router or PC.
- In a relatively clean, dust-free environment that allows easy access to the rear grounding post as well as the front panel controls and indicators. Air must be able to pass freely over the chassis.
- Accessible for service and troubleshooting.
- Protected from rain and extremes of temperature (it is designed for indoor use).

3.6.1.1 Installing on a Table Top or Cabinet

The MDS 5800 II SDIDU™ can be placed on a tabletop or cabinet shelf. In order to prevent possible disruption, it is recommended to use a strap to secure the SDIDU™.

3.6.1.2 Installing on a Wall

An installation option for the SDIDU™ is mounting the unit to a wall. Consult factory for details.

If the wall mount option is being considered, plan to position the MDS 5800 II SDIDU™ at a height that allows LEDs, the connectors on the front panel, and the rear grounding post to be visible at all times and easily accessible. Also, including plastic clamps to support and arrange the ODU/ SDIDU™ Interconnect Cable should also be considered.

3.6.1.3 Installing in a Rack

To rack-mount the SDIDU™, use the supplied mounting brackets to secure the chassis to the rack cabinet. As shown in Figure 3-6, the brackets can be attached at any of four points on the

sides of the enclosure – front, back, middle facing front, and middle facing back. This flexibility ensures compatibility with most rack mounting arrangements.

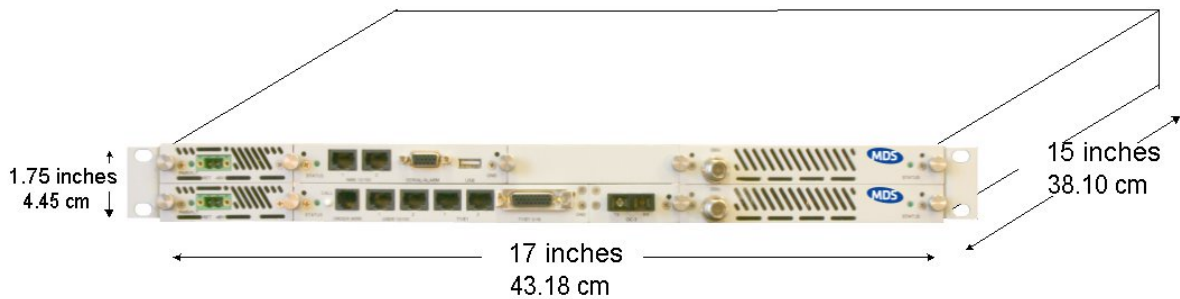

Figure 3-6. MDS 5800 II SDIDU™ Dimensions

3.6.2 Installing the MDS 5800 II ODU

The MDS 5800 II ODU is intended for mounting on either a pole or antenna mast.

Each site must be assessed for the mounting method, location, and height. After defining the mounting location and height for the MDS 5800 II ODU, re-confirm the line of sight.

3.6.2.1 Installing the Mounting Poles

First install the mounting poles, on which you will mount the **MDS 5800 II ODU**. It is important to note the direction in which the ODU will point when installing the mounting pole.

The mounting pole must be mounted in a vertical position. Failure to do so may result in improper alignment of the ODU. Vertical tilt of the ODU is accomplished from the tilt mounting bracket.

The mounting pole must be grounded.

Now that you have installed the mounting pole, you are ready to install the MDS 5800 II ODU onto the mounting poles. Reference Figure 3-7 through Figure 3-10.

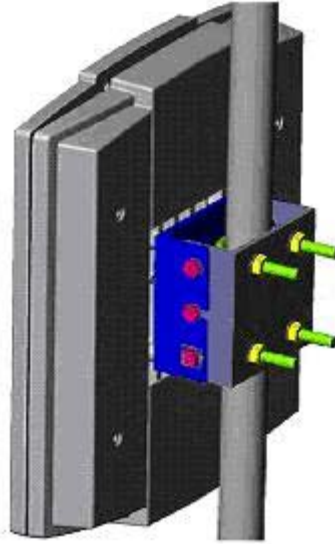

Figure 3-7. Mounting Parts for the MDS 5800 II ODU

1. Remove the pole mount portion of the tilt bracket from the ODU by loosening the middle bolts and removing the top and bottom bolts on each side.
2. Mount the tilt bracket to the mounting pole using the U-Bolts and nuts. Insert the U-bolts around the pole and through the holes in the tilt bracket. Install a washer and nut to each side of the threaded U-bolt and hand tighten. Repeat this step for the second U-bolt.
3. Place the MDS 5800 II ODU on the mating half of the tilt bracket connected by the two center bolts.
4. Add the remaining four bolts to the tilt bracket but do not tighten until the antenna alignment is complete (only applies for internal antenna ODUs).
5. Manually point the ODU in the direction of the link partner ODU.



Figure 3-8. MDS 5800 II ODU Rear View



Figure 3-9. Tilt Bracket



Figure 3-10. MDS 5800 II ODU with Mounted Tilt Bracket

3.6.3 Routing the ODU/ SDIDU™ Interconnect Cable

1. Select where the cable will enter the building from outside.
2. Determine the length of cable required. Allow three extra feet on each end to allow for strain relief, as well as any bends and turns.
3. Route the cable.

The SDIDU™ is equipped with TNC female connector on the front of the chassis. Depending on the ODU type, it will be equipped with either a N-type or TNC female connector at its interconnecting port. A length of coaxial cable (such as Times Microwave Systems LMR-400, LMR-300 or LMR-200) fitted with the appropriate N-type or TNC male connectors is required to connect the ODU to the SDIDU™. This cable assembly may be supplied in fixed lengths with the digital radio. Bulk coaxial cable of equivalent specification may also be used, with terminating connectors applied during cable installation.

Based on an evaluation of the cable routing path, pull the ODU/SDIDU™ Interconnect cable from one unit to the other, utilizing cable trays, ducts, or conduit as required. Take care that the ODU/SDIDU™ Interconnect cable is not kinked or damaged in any way during installation. Be sure to protect the TNC connectors from stress, damage and contamination during installation (do not pull the cable by the connectors). If multiple ODU/SDIDU™ Interconnect cables are to be installed along the same route, the cables should all be pulled at one time. Be sure the installed cable does not have any bends that exceed the specified cable bend radius. The ODU/SDIDU™ Interconnect cable should be adequately supported on horizontal runs and should be restrained by hangers or ties on vertical runs to reduce stress on the cable. Outside the building, support and restrain the cable as required by routing and environmental conditions (wind, ice).

The MDS 5800 II ODU/SDIDU™ and interconnection must be properly grounded in order to protect it and the structure it is installed on from lightning damage. This requires that the ODU, any mounting pole or mast and any exposed interconnect cable be grounded on the outside of the structure. The SDIDU™ must be grounded to a rack or structure ground that also has direct path to earth ground.

The ODU must be directly connected to a ground rod or equivalent earth ground. The ODU/SDIDU™ interconnect cable should also be grounded at the ODU, where the cable enters the structure and at intermediate points if the exposed cable run is long (typically at intervals of 100 ft), with the cable manufacturer's grounding kits. Lightning protection devices used with the interconnect cable must be appropriate for the transmission of the interconnect signals (DC to 350 MHz).

Provide a sufficient but not excessive length of cable at each end to allow easy connection to the ODU and SDIDU™ without stress or tension on the cable. Excessive cable length, especially outdoors, should be avoided to minimize signal attenuation and provide a more robust and reliable installation. If installing using bulk coaxial cable, terminate the ODU/SDIDU™ Interconnect cable at each end with a TNC male connector on the SDIDU™ side and either a N-type or TNC male connector on the ODU side that is appropriate for the cable type. Use of connectors, tools and termination procedures specified by the cable manufacturer is recommended.

Once the cable has been installed but before connection has been made to either unit, a simple DC continuity test should be made to verify the integrity of the installed cable. A DC continuity tester or digital multimeter may be used to verify a lack of DC continuity between the cable center conductor and outer conductor, with the opposite end of the cable unconnected. With a temporary test lead or shorting adapter connected to one end of the cable, DC continuity should be verified between the center and outer conductors at the opposite end.

3.6.4 Grounding the System

The MDS 5800 II IDU/ODU System must be properly grounded in order to protect it and the structure it is installed on from lightning damage. This requires:

3.6.4.1 Grounding the ODU

1. Place the grounding rod so as to allow for the shortest possible path from the grounding cable to the ODU.
2. Drive the grounding rod into the ground at least eight inches from the ground surface.
3. Attach a grounding clamp to the grounding rod. You will use this clamp to attach grounding wires for both the ODU and indoor junction box, reference Figure 3-11.

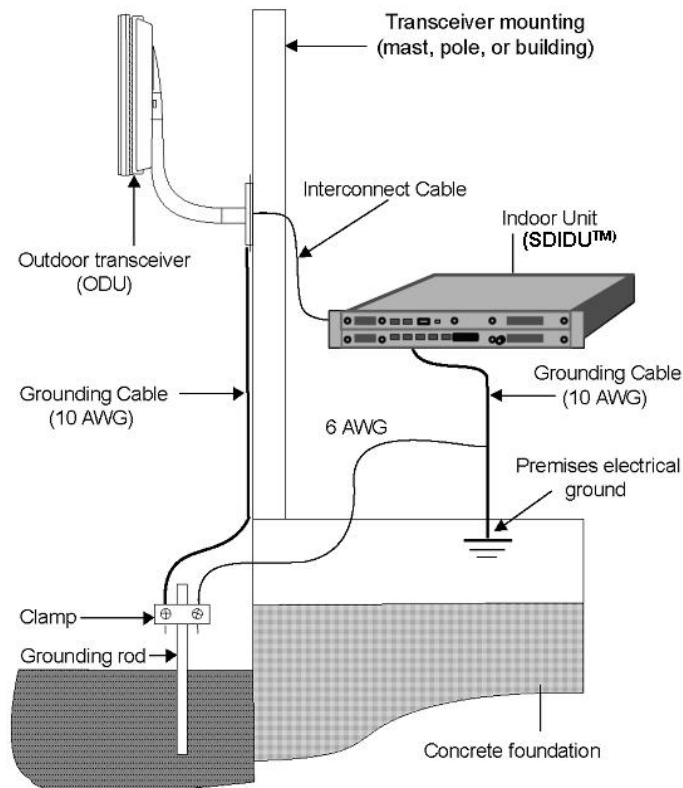

Figure 3-11 Ground Connections to ODU

4. Connect a ground lug to one end of the grounding wire.
5. Remove one of the lower mounting screws of the mounting pole. Insert a screw through the grounding lug terminal and re-install it to the mounting pole.
6. Attach the grounding wire to the clamp on the grounding rod. If necessary, use wire staples to secure the grounding wire to the outside wall.

Install a grounding wire from the junction box to the grounding rod.

3.6.4.2 Grounding the SDIDU™

1. Remove the nut and ring lug terminal from the SDIDU™ optional Chassis GND stud (located on the front panel).
2. The provided ring lug crimp terminal is intended to be used with 18 AWG wire (provided by the customer). The SDIDU™ should be able to be connected to a system or building electrical ground point (rack ground or power third-wire ground) with a cable of 36" or less.
3. Crimp the ring lug terminal to one end of the wire to be used as the SDIDU™ ground wire. Connect the opposite end of the SDIDU™ ground wire to the local source of ground in an appropriate manner.
4. Place the ring lug of the SDIDU™ ground cable on the SDIDU™ Chassis GND stud.
5. Place the nut on the SDIDU™ Chassis GND stud and tighten appropriately.

3.6.5 Connecting the SDIDU™ to the PC and Power Source

Perform the following steps to ensure the SDIDU™ is powered up and connected to you PC:

1. To connect to the SDIDU™ DC power connector (located on the left front SDIDU™ panel), an SDIDU™ power cable is required. A mating power cable connector (Phoenix Contact P/N 17 86 83 1) is provided with the MDS 5800 II SDIDU™ for construction of this cable. This connector has screw clamp terminals that accommodate 24 AWG to 12 AWG wire. The recommended wire size for construction of power cables under 10 feet in length, supplying -48 V dc, is 18 AWG. The opposite end of the SDIDU™ power cable should have a termination appropriate for the power supply being used. The SDIDU™ power cable should be of sufficient length to avoid tension in the cable and provide a service loop for connection, but not be of excessive length. Stranded wire should be used over a solid conductor to reduce tension on the SDIDU™ DC Power connector. Using the supplied power cable connector, pin 2 (labeled **-V**) should be connected to the power supply terminal supplying -48 V dc, while pin 1 (labeled **RET**) should be connected to the power supply return. Refer to Figure 3-5. Note that pin 1 (**RET**) of the SDIDU™ DC Power connector is connected to the SDIDU™ chassis ground internal to the SDIDU™. Use of a power supply with an inappropriate ground reference may cause damage to the SDIDU™ and/or the supply.
2. Connect the SDIDU™ power cable to the -48 V dc power supply, and place the voltmeter probes on the unconnected SDIDU™ end of the power cable, with the positive voltmeter probe on pin 2 (**-V**) of the cable connector and the negative probe on pin 1(**RET**). The connector screw terminal screw heads may be used as convenient monitor points. Refer to Figure 3-5.
3. Turn on the -48 V dc supply. Verify that the digital voltmeter reads between -44 V dc and -52 V dc when monitoring the cable points specified above. Adjust the power supply output voltage and/or change the connections at the power supply to achieve this reading.
4. With the negative voltmeter probe still on pin 1 (**RET**) of the power cable connector (and the power supply still on), press the positive voltmeter probe to the SDIDU™ chassis and verify a potential of zero volts between the SDIDU™ chassis and cable pin 1 (**RET**). If the measured potential is not zero, the power supply may be grounded incorrectly and should not be used in this condition with an SDIDU™. Note that this measurement assumes that the SDIDU™ is

installed and properly grounded. If this is not the case, the same measurement can be made between cable pin 1 (**RET**) and a convenient ground (such as an ac outlet third-wire ground).

5. Turn the -48 V dc supply off.
6. Plug the SDIDU™ power cable into the SDIDU™ front panel DC Power connector (**DC Input**). Place the voltmeter probes on the cable connector screw terminal screw heads as per step 2 above. Refer to Figure 3-12. Note that the MDS 5800 II SDIDU™ does not have a power on/off switch. When DC power is connected, the digital radio powers up and is operational. There can be up to 320 mW of RF power present at the antenna port. The antenna should be directed safely when power is applied.
7. Turn on the -48 V dc power supply, and verify that the reading on the digital voltmeter is as specified in step 3 above.
8. Turn the -48 V dc supply off.
9. Connect the SDIDU™ to the laptop computer, using a Cat-5 Ethernet cable or connect the SDIDU™ to a computer network, using a Cat-5 Ethernet cable. Connect the Ethernet cable to **NMS 1 or 2** connector on the SDIDU™ front panel. Refer to Figure 3-13 for the SDIDU™ front panel connections.

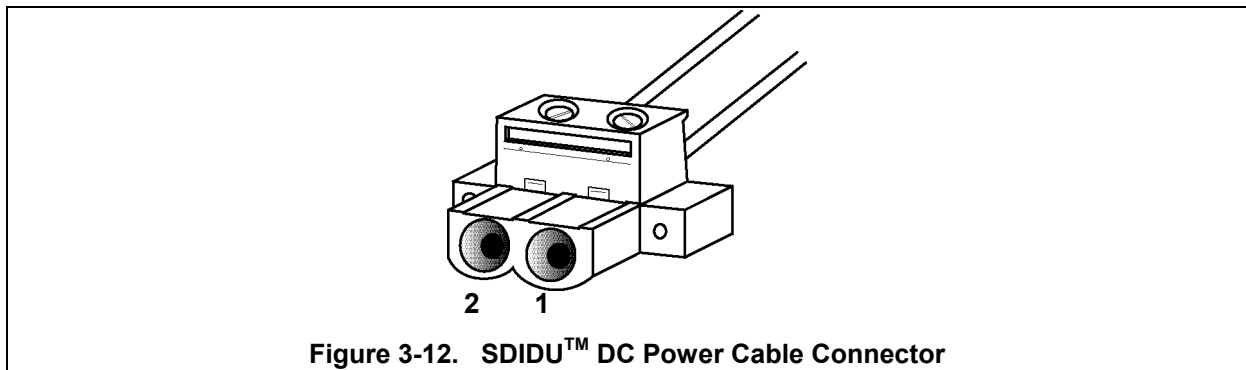

Figure 3-12. SDIDU™ DC Power Cable Connector

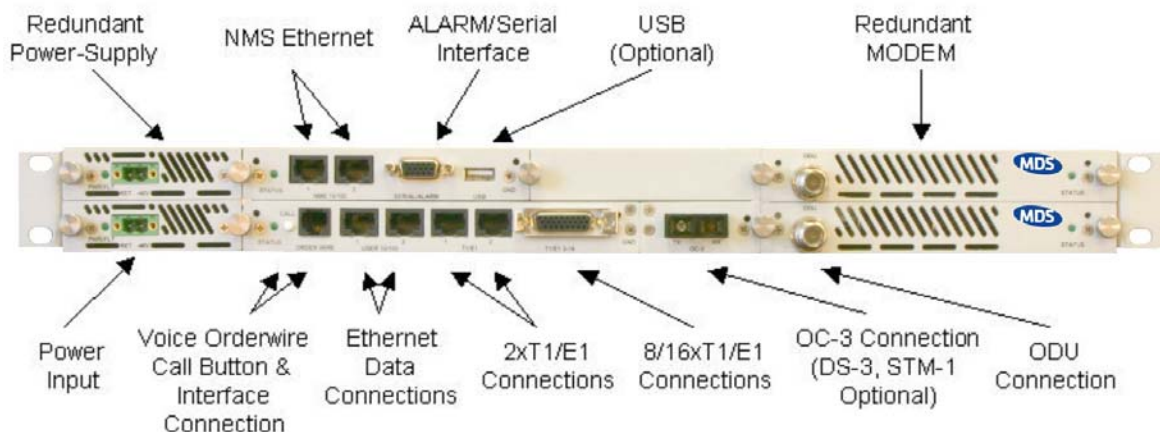

Figure 3-13. MDS 5800 II-SB, 1+1 Protection: SDIDU™ Front Panel Connections

3.7 MDS 5800 II Quick Start Guide

Configuration of the MDS 5800 II SDIDU™ does not require a connection to the ODU. It is suggested to configure the SDIDU™ prior to connecting to the ODU.

Each SDIDU has a Graphical User Interface (IDU) installed that can be accessed through a computer connection. The GUI is described in detail in the XXXX manual. The section below describes how to get started configuring the SDIDU™ via the GUI.

3.7.1 Materials Required

The following items are needed to configure an SDIDU™:

- Power supply (-48 V DC @ 2 Amps) **OR** optional AC/DC power supply and power cable
- Digital voltmeter with test leads
- SDIDU™ Serial Cable
- Computer with networking capability, consisting of either:
 - Laptop computer with Windows 98/2000/XP operating system, an Ethernet card with any necessary adapters and a Cat-5 Ethernet regular or crossover cable
 - or
 - Networked computer with Windows 98/2000/XP operating system and an additional Ethernet cable providing access to the network.
- Web Browser program with Java environment installed
- Site engineering folder with site drawings, or equivalent SDIDU configuration information

3.7.2 IDU Configuration Process

Using the site attributes identified in the site assessment or equivalent configuration information, configure each IDU by completing the following procedures:

- Connecting the SDIDU™ to the PC and Power Source
- Setting the SDIDU™ IP Address and Network Parameters
- Configuring the SDIDU™
- Setting the SDIDU™ Device Information

3.7.3 Connecting the SDIDU™ to the PC and Power Source

Perform the following steps to ensure the SDIDU™ is powered up and connected to you PC:

1. To connect to the SDIDU™ DC power connector (located on the left front SDIDU™ panel), an SDIDU™ power cable is required. A mating power cable connector (Phoenix Contact P/N 17 86 83 1) is provided with the MDS 5800 II SDIDU™ for construction of this cable. This connector has screw clamp terminals that accommodate 24 AWG to 12 AWG wire. The recommended wire size for construction of power cables under 10 feet in length, supplying -48 V dc, is 18 AWG. The opposite end of the SDIDU™ power cable should have a termination appropriate for the power supply being used. The SDIDU™ power cable should be of sufficient length to avoid tension in the cable and provide a service loop for connection, but not be of excessive length. Stranded wire should be used over a solid conductor to reduce tension on the SDIDU™ DC Power connector. Using the supplied power cable connector, pin 2 (labeled **-V**) should be connected to the power supply terminal supplying -48 V dc, while pin 1 (labeled **RET**) should be connected to the power supply return. Refer to Figure 3-14. Note that pin 1 (**RET**) of the SDIDU™ DC Power connector is connected to the SDIDU™ chassis ground internal to the SDIDU™. Use of a power supply with an inappropriate ground reference may cause damage to the SDIDU™ and/or the supply.
2. Connect the SDIDU™ power cable to the -48 V dc power supply, and place the voltmeter probes on the unconnected SDIDU™ end of the power cable, with the positive voltmeter probe on pin 2 (**-V**) of the cable connector and the negative probe on pin 1(**RET**). The connector screw terminal screw heads may be used as convenient monitor points. Refer to Figure 3-14.
3. Turn on the -48 V dc supply. Verify that the digital voltmeter reads between -44 V dc and -52 V dc when monitoring the cable points specified above. Adjust the power supply output voltage and/or change the connections at the power supply to achieve this reading.
4. With the negative voltmeter probe still on pin 1 (**RET**) of the power cable connector (and the power supply still on), press the positive voltmeter probe to the SDIDU™ chassis and verify a potential of zero volts between the SDIDU™ chassis and cable pin 1 (**RET**). If the measured potential is not zero, the power supply may be grounded incorrectly and should not be used in this condition with an SDIDU™. Note that this measurement assumes that the SDIDU™ is installed and properly grounded. If this is not the case, the same measurement can be made between cable pin 1 (**RET**) and a convenient ground (such as an ac outlet third-wire ground).
5. Turn the -48 V dc supply off.
6. Plug the SDIDU™ power cable into the SDIDU™ front panel DC Power connector (**DC Input**). Place the voltmeter probes on the cable connector screw terminal screw heads as per step 2 above. Refer to Figure 3-5. Note that the MDS 5800 II SDIDU™ does not have a power on/off switch. When DC power is connected, the digital radio powers up and is operational. There can be up to 320 mW of RF power present at the antenna port. The antenna should be directed safely when power is applied.
7. Turn on the -48 V dc power supply, and verify that the reading on the digital voltmeter is as specified in step 3 above.
8. Turn the -48 V dc supply off.

9. Connect the SDIDU™ to the laptop computer, using a Cat-5 Ethernet cable or connect the SDIDU™ to a computer network, using a Cat-5 Ethernet cable. Connect the Ethernet cable to **NMS 1 or 2** connector on the SDIDU™ front panel. Refer to Figure 2-2 for the SDIDU™ front panel connections.

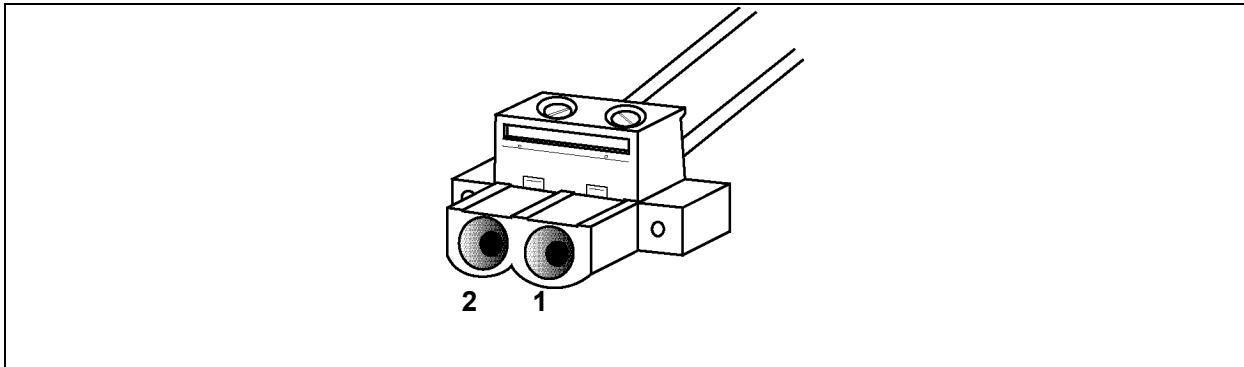

Figure 3-14. SDIDU™ DC Power Cable Connector

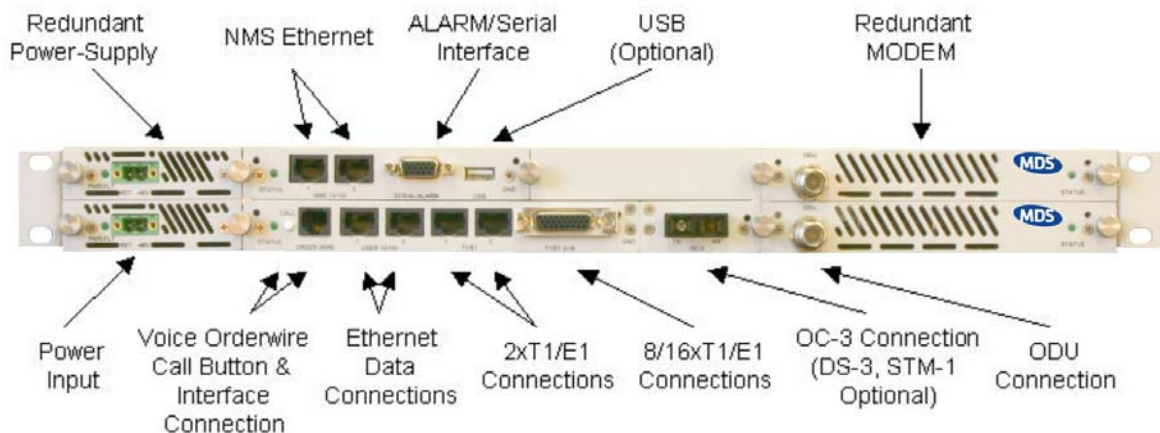

Figure 3-15. MDS 5800 II-SB, 1+1 Protection: SDIDU™ Front Panel Connections

3.7.3.1 Setting the IDU IP Address

To manage the MDS 5800 II remotely the IP address of the radio must be set. If the SDIDU™ IP address is set to the factory default or any known value. Use a web browser to access the SDIDU™ GUI and set the IP address as follows as described in section 3.7.3.1.1. If the IP address is unknown, a hyperterminal connection via a serial cable can be used as described in section 3.7.3.1.2.

3.7.3.1.1 Using the GUI to set the IP address

1. The IDU should be accessible from your PC. A network 'ping' can be done to verify connectivity to the IDU.

- A. On your desktop, click the **Start** button and select **Programs**. Then click on the **MS-DOS Prompt** icon.
- B. In the MS-DOS window, type ping 192.168.0.1 and press enter. 192.168.0.1 is the default factory IP address.
- C. If the ping is successful, the following message will appear: Reply from 192.168.0.1: bytes=a. time=b ms, TTL=c. Refer to Figure 3-16 for an example of a ping. A successful ping implies that the SDIDU™ and the PC can communicate with one another across an Ethernet connection.
- D. Close the MS-DOS prompt window.

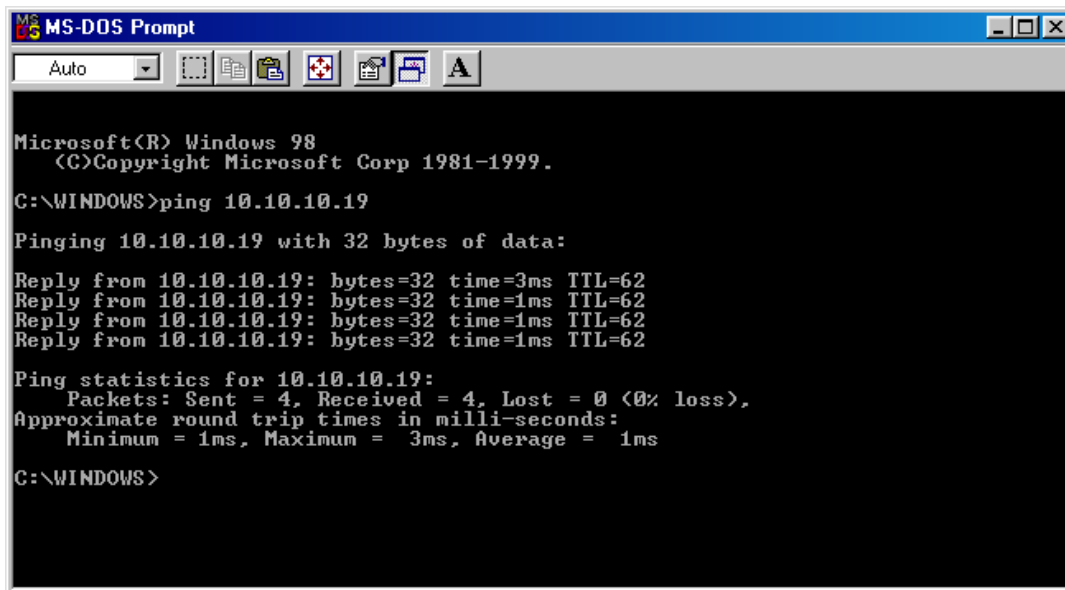

```
Microsoft(R) Windows 98
(C)Copyright Microsoft Corp 1981-1999.
C:\WINDOWS>ping 10.10.10.19
Pinging 10.10.10.19 with 32 bytes of data:

Reply from 10.10.10.19: bytes=32 time=3ms TTL=62
Reply from 10.10.10.19: bytes=32 time=1ms TTL=62
Reply from 10.10.10.19: bytes=32 time=1ms TTL=62
Reply from 10.10.10.19: bytes=32 time=1ms TTL=62

Ping statistics for 10.10.10.19:
    Packets: Sent = 4, Received = 4, Lost = 0 (0% loss),
    Approximate round trip times in milli-seconds:
        Minimum = 1ms, Maximum = 3ms, Average = 1ms
C:\WINDOWS>
```

Figure 3-16 IDU Ping Example

2. Start a web browser and use the SDIDU™ default IP address (192.168.0.1) as the url.
3. Log in at the login prompt..
4. The GUI includes a navigation menu in the left frame. If this navigation menu is not visible, make sure the Java environment is properly installed and active. In the navigation menu, select Administration, then Network Configuration, and then General. The IP address, IP Netmask, and IP Gateway are shown.
5. Enter the new IP address, IP Netmask, and IP Gateway. The gateway must be in the same subnet as the IP address for proper operation. Click Update to change the values.
6. To verify the IP address, repeat step 1 using the new address.
7. To continue using the GUI, point the web browser to the new IP address.

3.7.3.1.2 Using a terminal connection to set the IP address

1. Connect the Serial/Alarm port on the SDIDU™ to a COM port on the computer.

2. Start a hyperterminal session and select the following COM port settings:
 - Bits per second: 38400
 - Data bits: 8
 - Parity: None
 - Stop bits: 1
 - Flow control: None
3. The following terminal and ASCII settings are recommended for best viewing:
 - Emulation: VT100
 - Line delay: 50 ms
 - Character delay: 10 ms
 - Text wrap: On
4. Connect to the SDIDU™. Once the connections complete, power on the SDIDU™.
5. Press the keyboard return key to receive a login prompt. Log in.
6. Press the M-key to navigate to the Main Menu.
7. Press the B-key to navigate to Administration.
8. Press the A-key to navigate to Network Configuration.
9. Press the A-key to navigate to General.
10. Press the A-key to navigate to IP Address.
11. Enter the new IP address and press the D-Key to update. If the IP address has been entered correctly enter Y when prompted.
12. If necessary, use the same menus to set the IP Netmask and IP Gateway.
13. Close the hyperterminal connection.

3.7.3.2 Configuring the SDIDU™

Use the GUI to configure the SDIDU™ as follows:

1. To start the GUI, open a web browser and use the SDIDU™ IP address (192.168.0.1) as the url and log in when prompted.
2. Use the frame on the left side of the window to navigate to “Radio Link.”

3. Select the subcategory “Link Configuration.”
4. Select the operating mode. If the SDIDU™ has one modem installed and is connected to one ODU, select standard. If the SDIDU™ has two modems installed and is connected to two ODUs, select 1+1 diversity or 1+1 non-diversity for a protected link (as described in section 2.10) or east-west for a 2+0 ring configuration (as described in section 2.11).
5. Follow the wizard located here to enter the rest of the required settings.

3.7.3.3 Configuring the SDIDU™ Site Attributes

Use the GUI to enter device information as follows:

1. In the navigation menu, select Administration, then Device Information, and then Device Names.
2. Enter the Owner, Contact, Description, and Location. These values are not required for operation, but will help keep a system organized.

3.7.4 ODU Antenna Alignment

To use the built-in tuning of the ODU antenna, a complete link is required, with both ends of the link roughly pointed at each other, and transmitting.

Once the links are roughly pointed, place the local SDIDUTM in “ODU Alignment” mode. This mode outputs 0 to +3 Volts on the RSSI (Receive Signal Strength Indication) BNC connector seen on the ODU. This voltage is read on a voltmeter during alignment while the antenna is adjusted for maximum voltage. The RSSI voltage is linearly calibrated from 2.5 Volts for maximum RSL (received signal level) at -20 dBm to 0Volts for minimum RSL at -90 dBm. This mapping characteristic is plotted below in Figure 3-17.

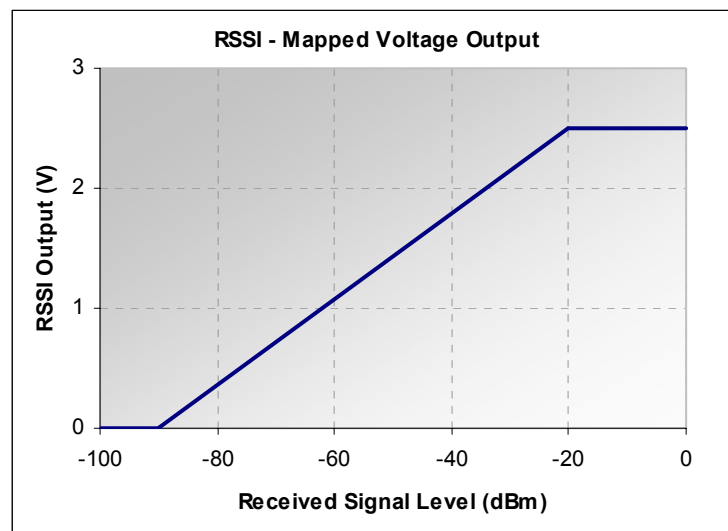

Figure 3-17. ODU RSSI Output vs. Received Signal.

3.7.5 Documenting MDS 5800 II Configuration

Use the MDS 5800 II configuration form provided at the end of this section, or a similar form, to document the results of the IDU configuration procedure. Optimally, this complete site form would be stored with the IDU for future reference.

Digital Radio Configuration Form

1

Link ID

Radio Type (A/B) A=Low band, Horizontal polarization, odd serial number
B=High band & Vertical polarization, even serial number

Radio ID # Radio S/N

Site Name

Network Administration - Radio	
Addresses	
Near IP:	<input type="text"/>
Far IP:	<input type="text"/>
Routing	
Net Mask:	<input type="text"/>
NTP:	<input type="text"/>
Gateway:	<input type="text"/>
SNMP Community Names	
Trap:	<input type="text"/>
Read/Write:	<input type="text"/>
Super User:	<input type="text"/>
Read:	<input type="text"/>
IP EMS 1:	<input type="text"/>
IP EMS 2:	<input type="text"/>
IP EMS 3:	<input type="text"/>
IP EMS 4:	<input type="text"/>

Link Administration - Radio	
Commissioning:	
Rain Model	<input type="text"/>
Frequency	TX <input type="text"/> RX <input type="text"/>
Grade of Service	<input type="text"/>
Rain Region	<input type="text"/>
Link Distance	
Distance (meters)	<input type="text"/>
OR	
GPS Location	
Near Latitude	<input type="text"/> deg <input type="text"/> min <input type="text"/> sec
Near Longitude	<input type="text"/> deg <input type="text"/> min <input type="text"/> sec
Far Latitude	<input type="text"/> deg <input type="text"/> min <input type="text"/> sec
Far Longitude	<input type="text"/> deg <input type="text"/> min <input type="text"/> sec

Radio Type (A/B)

Radio ID# Radio S/N

Site Name

Network Administration - IFU	
Addresses	
Near IP:	<input type="text"/>
Far IP:	<input type="text"/>
Routing	
Net Mask:	<input type="text"/>
NTP:	<input type="text"/>
Gateway:	<input type="text"/>
SNMP Community Names	
Trap:	<input type="text"/>
Read/Write:	<input type="text"/>
Super User:	<input type="text"/>
Read:	<input type="text"/>
IP EMS 1:	<input type="text"/>
IP EMS 2:	<input type="text"/>
IP EMS 3:	<input type="text"/>
IP EMS 4:	<input type="text"/>

2

Link Administration - Radio	
Commissioning:	
Rain Model	<input type="text"/>
Frequency	TX <input type="text"/> RX <input type="text"/>
Grade of Service	<input type="text"/>
Rain Region	<input type="text"/>
Link Distance	
Distance (meters)	<input type="text"/>
OR	
GPS Location	
Near Latitude	<input type="text"/> deg <input type="text"/> min <input type="text"/> sec
Near Longitude	<input type="text"/> deg <input type="text"/> min <input type="text"/> sec
Far Latitude	<input type="text"/> deg <input type="text"/> min <input type="text"/> sec
Far Longitude	<input type="text"/> deg <input type="text"/> min <input type="text"/> sec

4 Summary Specification

Parameter	5800	5300
System		
Capacity	100 Mbps Ethernet 4-16 T1/E1 Various combinations of above	100 Mbps Ethernet 4-16 T1/E1 Various combinations of above
Output Power – Average (at antenna port)	-8 to 22.5 dBm	-18 to 7 dBm
Output Power – Peak (at antenna port)	30 dBm	17 dBm
Input Sensitivity	-81 dBm (or higher, based on selected mode)	-81 dBm (or higher, based on selected mode)
Maximum Input Power	-20 dBm	-20 dBm
Modulation	BPSK to 64-QAM	BPSK to 64-QAM
Channelization	12.5, 16.7, 25, 30 MHz	13.3, 20, 30 MHz
Radio Interfaces		
External Antenna	N Type Female	N Type Female
SDIDU™ /ODU Link	TNC Female	TNC Female
RSSI	BNC Female	BNC Female
Data Interfaces		
Payload Ethernet 2 T1/E1 14 T1/E1	100Base-Tx RJ-45 RJ-48C Female (2) Molex High-Density 60-pin	100Base-Tx RJ-45 RJ-48C Female (2) Molex High-Density 60-pin
SNMP	10Base-T/100Base-Tx RJ-45 Female	10Base-T/100Base-Tx RJ-45 Female
Control		
Network Management	SNMP, web/http browser	SNMP, web/http browser
NMS Connector	10Base-T/100Base-Tx	10Base-T/100Base-Tx
Encryption	Proprietary, AES (optional)	Proprietary, AES (optional)
Alarm Port	2 Form C (SPDT), 2 TTL Output, 4 TTL Input, DB-15HD	2 Form C (SPDT), 2 TTL Output, 4 TTL Input, DB-15HD

Parameter	5800	5300
Power/Environment		
DC Power	-48 Volts \pm 10%, <100 W	-48 Volts \pm 10%, <100 W
SDIDU™ Operational Temperature	-5° to 55° C	-5° to 55° C
ODU Operational Temperature	-30° to 55° C	-30° to 55° C
SDIDU™ Humidity	0 to 95%, non-condensing	0 to 95%, non-condensing
ODU Humidity	Up to 100% at 45° C	Up to 100% at 45° C
Altitude	15,000 feet/4572 meters, maximum	15,000 feet/4572 meters, maximum
Physical Dimensions		
SDIDU™ Size (WxHxD)	17.2 x 1.75 x 14.5 inches (43.7 x 4.5 x 36.0 cm)	17.2 x 1.75 x 14.5 inches (43.7 x 4.5 x 36.0 cm)
SDIDU™ Weight	7 lbs (3.12 Kg)	7 lbs (3.12 Kg)
SDIDU™ Mounting/Installation		
EIA Rack Mount	19 inch/48.2 cm, 1 rack unit	19 inch/48.2 cm, 1 rack unit
ODU Size (W x H x D)	14.6 x 15.4 x 2.6 inches	14.6 x 15.4 x 2.6 inches
ODU Weight	15 lbs (6.8 Kgs)	15 lbs (6.8 Kg)
ODU Mounting/Installation		
Mounting	Custom Bracket	Custom Bracket

5 Front Panel Connectors

5.1 DC Input (Power) Connector

Two-pin male

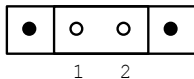

PIN	TYPE	SIGNAL
1	POWER	Power supply return
2	POWER	-48 Vdc, nominal

5.2 Ethernet 100BaseTX Payload Connector 1-2

RJ-45 Female

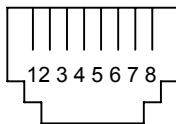

PIN	TYPE	SIGNAL
1	INPUT	RX+
2	INPUT	RX-
3	OUTPUT	TX+
4	N/A	N/A
5	N/A	N/A
6	OUTPUT	TX-
7	N/A	N/A
8	N/A	N/A

5.3 SONET Payload Connector

SC Duplex Female Fiber

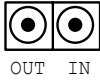

PIN	TYPE	SIGNAL
OUT	OUTPUT	SONET OC-3 payload output (optical)
IN	INPUT	SONET OC-3 payload input (optical)

5.4 STM-1 Payload Connector

BNC Duplex

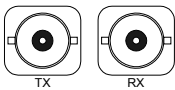

PIN	TYPE	SIGNAL
TX	OUTPUT	SDH STM-1 payload output (electrical)
RX	INPUT	SDH STM-1 payload input (electrical)

5.5 DS-3/E-3/STS-1 Payload Connector

BNC Duplex

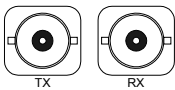

PIN	TYPE	SIGNAL
TX	OUTPUT	DS-3/E-3/STS-1 payload output
RX	INPUT	DS-3/E-3/STS-1 payload input

5.6 NMS 10/100BaseTX Connector 1-2

RJ-45 Female

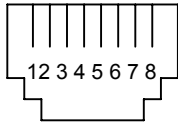

PIN	TYPE	SIGNAL
1	OUTPUT	TX+
2	OUTPUT	TX-
3	INPUT	RX+
4	N/A	N/A
5	N/A	N/A
6	INPUT	RX-
7	N/A	N/A
8	N/A	N/A

5.7 Alarm/Serial Port Connector

DB-15HD Female



PIN	TYPE	SIGNAL
1	OUTPUT	TTL Alarm Output 3
2 ¹	INPUT/ Output	RS-232 RX/TX
3 ¹	OUTPUT /Input	RS-232 TX/RX
4	OUTPUT	TTL Alarm Output 4
5	N/A	GROUND
6 ²	N/A	Alarm 1 Form C Contact Normally Open
7 ²	N/A	Alarm 1 Form C Contact Normally Closed
8 ²	N/A	Alarm 2 Form C Contact Common
9	INPUT	TTL Alarm Input 1
10	INPUT	TTL Alarm Input 3
11 ²	N/A	Alarm 1 Form C Contact Common
12 ²	N/A	Alarm 2 Form C Contact Normally Open
13 ²	N/A	Alarm 2 Form C Contact Normally Closed
14	INPUT	TTL Alarm Input 2
15	Input	TTL Alarm Input 4

¹ Pins 2 and 3 are hardware jumper configurable for DCE or DTE operation.

² Form C Contacts are hardware jumper configurable to emulate TTL outputs.

5.8 ODU Connector

TNC coaxial female

PIN	TYPE	SIGNAL
Center	I/O	350 MHz TX IF / 140 MHz RX IF / -48 VDC
Shield	N/A	Shield / Chassis GND

5.9 T1- Channels 1-2 Connector

RJ-48C Female

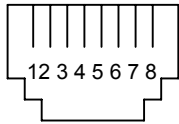

PIN	TYPE	SIGNAL
1	INPUT	RX+
2	INPUT	RX-
3	N/A	GND
4	OUTPUT	TX+
5	OUTPUT	TX-
6	N/A	GND
7	N/A	N/A
8	N/A	N/A

5.10 T1- Channels 3-16 Connector

60-pin Molex

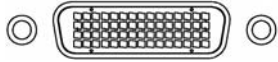

PIN	TYPE	SIGNAL
1	OUTPUT	T1 Channel 13 Transmit Tip
2	OUTPUT	T1 Channel 14 Transmit Tip
3	OUTPUT	T1 Channel 15 Transmit Tip
4	OUTPUT	T1 Channel 16 Transmit Tip
5	OUTPUT	T1 Channel 9 Transmit Tip
6	OUTPUT	T1 Channel 10 Transmit Tip
7	OUTPUT	T1 Channel 11 Transmit Tip
8	OUTPUT	T1 Channel 12 Transmit Tip
9	OUTPUT	T1 Channel 5 Transmit Tip
10	OUTPUT	T1 Channel 6 Transmit Tip
11	OUTPUT	T1 Channel 7 Transmit Tip
12	OUTPUT	T1 Channel 8 Transmit Tip
13	OUTPUT	T1 Channel 3 Transmit Tip
14	OUTPUT	T1 Channel 4 Transmit Tip
15	NC	NC
16	NC	NC
17	OUTPUT	T1 Channel 4 Transmit Ring
18	OUTPUT	T1 Channel 3 Transmit Ring
19	OUTPUT	T1 Channel 8 Transmit Ring
20	OUTPUT	T1 Channel 7 Transmit Ring
21	OUTPUT	T1 Channel 6 Transmit Ring
22	OUTPUT	T1 Channel 5 Transmit Ring

PIN	TYPE	SIGNAL
23	OUTPUT	T1 Channel 12 Transmit Ring
24	OUTPUT	T1 Channel 11 Transmit Ring
25	OUTPUT	T1 Channel 10 Transmit Ring
26	OUTPUT	T1 Channel 9 Transmit Ring
27	OUTPUT	T1 Channel 16 Transmit Ring
28	OUTPUT	T1 Channel 15 Transmit Ring
29	OUTPUT	T1 Channel 14 Transmit Ring
30	OUTPUT	T1 Channel 13 Transmit Ring
31	INPUT	T1 Channel 16 Receive Tip
32	INPUT	T1 Channel 15 Receive Tip
33	INPUT	T1 Channel 9 Receive Tip
34	INPUT	T1 Channel 14 Receive Tip
35	INPUT	T1 Channel 10 Receive Tip
36	INPUT	T1 Channel 13 Receive Tip
37	INPUT	T1 Channel 11 Receive Tip
38	INPUT	T1 Channel 4 Receive Tip
39	INPUT	T1 Channel 12 Receive Tip
40	INPUT	T1 Channel 3 Receive Tip
41	INPUT	T1 Channel 5 Receive Tip
42	INPUT	T1 Channel 8 Receive Tip
43	INPUT	T1 Channel 6 Receive Tip
44	INPUT	T1 Channel 7 Receive Tip
45	NC	NC
46	NC	NC
47	INPUT	T1 Channel 7 Receive Ring

PIN	TYPE	SIGNAL
48	INPUT	T1 Channel 6 Receive Ring
49	INPUT	T1 Channel 8 Receive Ring
50	INPUT	T1 Channel 5 Receive Ring
51	INPUT	T1 Channel 3 Receive Ring
52	INPUT	T1 Channel 12 Receive Ring
53	INPUT	T1 Channel 4 Receive Ring
54	INPUT	T1 Channel 11 Receive Ring
55	INPUT	T1 Channel 13 Receive Ring
56	INPUT	T1 Channel 10 Receive Ring
57	INPUT	T1 Channel 14 Receive Ring
58	INPUT	T1 Channel 9 Receive Ring
59	INPUT	T1 Channel 15 Receive Ring
60	INPUT	T1 Channel 16 Receive Ring

5.11 USB

USB Type A

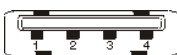

PIN	TYPE	SIGNAL
1	OUTPUT	+5V
2	I/O	-Data
3	I/O	+Data
4	N/A	GND

5.12 Voice Order Wire

RJ-48C Female

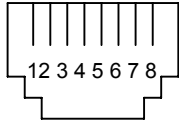

PIN	TYPE	SIGNAL
1	N/A	NC
2	INPUT	PTT
3	N/A	GND
4	OUTPUT	PO-
5	OUTPUT	PO+
6	INPUT	TI-
7	N/A	GND
8	N/A	NC

5.13 Data Order Wire

RJ-48C Female

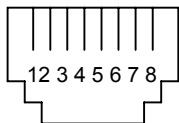

PIN	TYPE	RS 422 SIGNAL	RS232 SIGNAL
1	OUTPUT	TX Clock -	NC
2	OUTPUT	TX Clock +	NC
3	OUTPUT	TX Data -	NC
4	INPUT	RX Data -	NC
5	INPUT	RX Data +	Rx Data
6	OUTPUT	TX Data +	Tx Data
7	INPUT	RX Clock -	NC
8	INPUT	RX Clock +	NC

6 Appendix

6.1 Abbreviations & Acronyms

A/D, ADC	Analog-to-Digital, Analog-to-Digital Converter
ABAM	Designation of Lucent for twisted pair cable to connect ADM switch to T1 distribution panel
ADM	Add/Drop Multiplexer
ADPCM	Adaptive Differential Pulse Code Modulation
A _d TPC	Adaptive Power Control
AGC	Auto Gain Control
AIS	Alarm Indication Signal
ATM	Asynchronous Transfer Mode
BER	Bit Error Rate
CLEC	Competitive Local Exchange Carrier
CMRR	Common Mode Rejection Ratio
CO	Central Office
Codec	Coder-Decoder
CPE	Customer Premise Equipment
CPU	Central Processing Unit
CPFSK	Continuous-Phase Frequency Shift Keying
CSU	Channel Service Unit
D/A, DAC	Digital-to-Analog, Digital-to-Analog Converter
DB	Decibel
DBc	Decibel relative to carrier
DBm	Decibel relative to 1 mW
DBu	Decibel relative to .775 V _{rms}
DCE	Data Circuit-Terminating Equipment
DMM	Digital Modem Module
DSP	Digital Signal Processing
DSTL	Digital Studio-Transmitter Link
DTE	Data Terminal Equipment
DVM	Digital Voltmeter

EIRP	Effective Isotropic Radiated Power
EMI	Electromagnetic Interference
EMS	Element Management System
ESD	Electrostatic Discharge/Electrostatic Damage
FCC	Federal Communications Commission
FEC	Forward Error Correction
FET	Field effect transistor
FMO	Frequency Modulation Oscillator
FPGA	Field Programmable Gate Array
FSK	Frequency Shift Keying
FT1	Fractional T1
GPI	General Purpose Input
HP OpenView®	Hewlett Packard's network management product
IC	Integrated circuit
IEC	International Electrotechnical Commission
IF	Intermediate frequency
IMD	Intermodulation Distortion
IP	Internet Protocol
ISDN	Integrated-Services Digital Network
ISM	Industrial, Scientific, and Medical
ISP	Internet Service Provider
ITU	International Telecommunications Union
Kbps	Kilobits per second
kHz	Kilohertz
LAN	Local Area Network
LED	Light-emitting diode
LOS	Line of Sight
LO, LO1	Local oscillator, first local oscillator
LSB	Least significant bit
MAN	Metropolitan Area Network
Mbps	Megabits per second
MIB	Management Information Base
Modem	Modulator-demodulator
MMW	Millimeter Wave
ms	Millisecond
MSB	Most significant bit

MUX	Multiplex, Multiplexer
μ s	Microsecond
μ V	Microvolts
NC	Normally closed
NIC	Network Interface Card
NMS	Network Management System
NO	Normally open
NOC	Network Operations Center
OAM&P	Operations, Administration, Maintenance, and Provisioning
OC-3	Optical Carrier level 3
ODU	Outdoor Unit
OS	Operating System
PCB	Printed circuit board
PCM	Pulse Code Modulation
PGM	Program
PLL	Phase-Locked Loop
POP	Point of Presence
PRBS	Pseudo Random Bit Stream
QAM	Quadrature Amplitude Modulation
QPSK	Quadrature Phase Shift Keying
R	Transmission Rate
RF	Radio Frequency
ROH	Radio Overhead
RPTR	Repeater
RSL	Received Signal Level (in dBm)
RSSI	Received Signal Strength Indicator/Indication
RX	Receiver
SCA	Subsidiary Communications Authorization
SCADA	Security Control and Data Acquisition
SDH	Synchronous Digital Hierarchy
SNMP	Simple Network Management Protocol
SNR	Signal-to-Noise Ratio
SDIDU™	Software Defined Indoor Unit (CarrierComm trademark)
SONET	Synchronous Optical Network
SQM	Signal Quality Metric
SRD	Step Recovery Diode

STL	Studio-Transmitter Link
STM-1	Synchronous Transport Module 1
TCM	Trellis Coded Modulation
TCP/IP	Transmission Control Protocol/Internet Protocol
TDM	Time Division Multiplexing
THD	Total harmonic distortion
TP	Test Point
TTL	Transistor-transistor logic
TX	Transmitter
Vrms	Volts root-mean-square
Vp	Volts peak
Vp-p	Volts peak-to-peak
VOIP	Voice Over Internet Protocol
VPN	Virtual Private Network
VRMS	Volts, root-mean-square
VSWR	Voltage standing-wave ratio
WAN	Wide Area Network
ZIN	Input Impedance
ZOUT	Output Impedance



IN CASE OF DIFFICULTY...

MDS products are designed for long life and trouble-free operation. However, this equipment, as with all electronic equipment, may have an occasional component failure. The following information will assist you in the event that servicing becomes necessary.

TECHNICAL ASSISTANCE

Technical assistance for MDS products is available from our Technical Support Department during business hours (8:00 A.M.–5:30 P.M. Eastern Time). When calling, please give the complete model number of the radio, along with a description of the trouble/symptom(s) that you are experiencing. In many cases, problems can be resolved over the telephone, without the need for returning the unit to the factory. Please use one of the following means for product assistance:

Phone: 585 241-5510 E-Mail: <mailto:TechSupport@microwavedata.com>

FAX: 585 242-8369 Web: <http://www.microwavedata.com/>

FACTORY SERVICE

Component level repair of radio equipment is not recommended in the field. Many components are installed using surface mount technology, which requires specialized training and equipment for proper servicing. For this reason, the equipment should be returned to the factory for any PC board repairs. The factory is best equipped to diagnose, repair and align your radio to its proper operating specifications.

If return of the equipment is necessary, you will be issued a Service Request Order (SRO) number and return shipping address. The SRO number will help expedite the repair so that the equipment can be repaired and returned to you as quickly as possible. Please be sure to include the SRO number on the outside of the shipping box, and on any correspondence relating to the repair. No equipment will be accepted for repair without an SRO number.

A statement should accompany the radio describing, in detail, the trouble symptom(s), and a description of any associated equipment normally connected to the radio. It is also important to include the name and telephone number of a person in your organization who can be contacted if additional information is required.

The radio must be properly packed for return to the factory. The original shipping container and packaging materials should be used whenever possible.

When repairs have been completed, the equipment will be returned to you by the same shipping method used to send it to the factory. Please specify if you wish to make different shipping arrangements. To inquire about an in-process repair, you may contact our Product Services Group at 585-241-5540 (FAX: 585-242-8400), or via e-mail at: ProductServices@microwavedata.com
