



4.0 EVALUATION BOARD DOCUMENTATION

This section contains an assembly drawing and parts list for the OEM Evaluation Board. In addition, a separate foldout schematic of the Board is included at the back of this manual. Board documentation is provided to assist integrators who need to create compatible interface circuitry between the OEM transceiver and host equipment.

NOTE: The foldout schematic may also be accessed from the TransNET Support Package CD, or from our website at: www.microwavedata.com.

4.1 Assembly Drawing

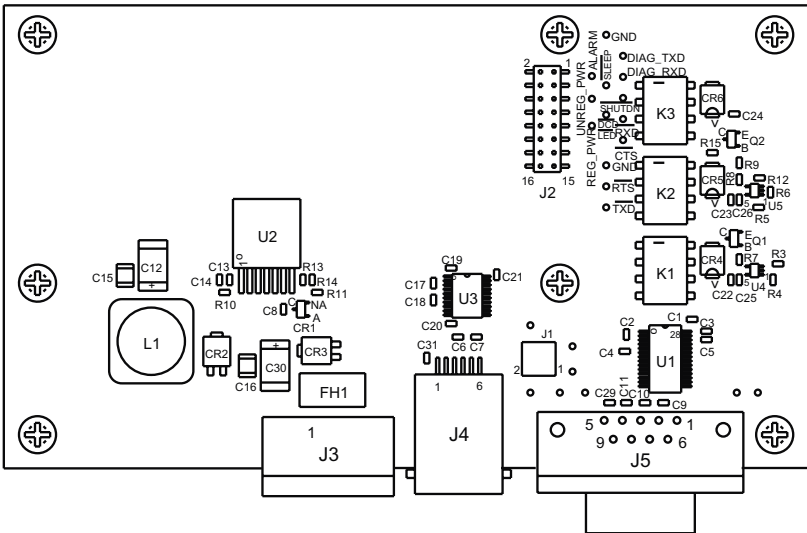

Figure 14. Evaluation Board Assembly Diagram

4.2 Parts List

Table 6 lists the electronic components used on the Evaluation Board.

Table 6. OEM Evaluation Board Parts List

| Ref. Desig. | Part Description |
|-------------|--|
| CR1 | DIODE, SOT23 SMALL SIG 914 5D |
| CR4 CR5 CR6 | RECTIFIER, 30V B13 |
| CR2 CR3 | DIODE, SCHOTTKY POWER, SMT, SNGL, UPS840 |
| Q1 Q2 | TRANSISTOR, SOT23 NPN 6429 M1LR |

Table 6. OEM Evaluation Board Parts List (Continued)

| | |
|---|--|
| U4 U5 | IC, LINEAR SC70-5 COMPARATOR SINGLE LMV33 |
| U1 | IC, IN'FACE SSOP28 RS-232 TXVR SP3238E |
| U3 | IC, IN'FACE 20PIN TSSOP DRIVER SP3222 |
| U2 | IC, SWITCHING REG'R ADJ.4.5A LT1374HVIR |
| K1 K2 K3 | RELAY, DPDT |
| R10 | RESISTOR, CHIP 0603 1/16W 5% 2.2K |
| R4 R5 R13 R14 | RESISTOR, CHIP 0603 1/10W 1% 10K |
| R12 | RESISTOR, CHIP 0603 1/10W 1% 100K |
| R7 R9 | RESISTOR, CHIP 0603 1/10W 1% 1.5K |
| R11 | RESISTOR, CHIP 0603 1/10W 1% 1.82K |
| R3 | RESISTOR, CHIP 0603 1/10W 1% 22.6K |
| R15 | RESISTOR, CHIP 0603 1/10W 1% 31.6K |
| R8 | RESISTOR, CHIP 0603 1/10W 1% 470 OHM |
| R6 | RESISTOR, CHIP 0603 1/10W 1% 6.81K |
| C12 | CAP, TANT 7343 20% 10V 100uf |
| C6 C7 C9 C10 C11 C29 C31 | CAP, CHIP 0603 50V NPO 5% 100pf |
| C1 C2 C3 C4 C5 C17 C18 C19 C20 C21 C22 C23 C24 C25 C26 C8 | CAP, CHIP 0603 X7R 10% 0.1uF |
| C13 | CAP, CHIP 0603 X7R 10% 470 pf |
| C14 | CAP, CHIP 0603 X7R 10% 4700pF |
| C15 | Capacitor, Low ESR Chip Ceramic, 1210 22uF |
| C16 | Capacitor, Low ESR Chip Ceramic, 1210 4.7 |
| L1 | INDUCTOR, SWITCHING, 20%, 10uH |
| J1 | CONN, HEADER, .100 DUAL STR 4-PIN |
| P/O J1 1-2, P/O J1 3-4 | CONN, JUMPER |
| FH1 | FUSE HOLDER, PCB SMT W/2A SLO-BLO FUSE |



Table 6. OEM Evaluation Board Parts List (Continued)

| | |
|----|--|
| J2 | CONN, HEADER, PC MOUNT .078, DUAL, 16 PIN Samtec TW Series, Part No: ASP 103812-01 <i>(Mates with J3 on the OEM radio transceiver)</i> |
| J3 | CONN, TERM STRIP, 5MM PCB |
| J4 | CONN, TELE JACK 6POS 6CON RT A SMT W/F |
| J5 | CONN, D-SUB, PCB RCPT 90 DEGREE, 9 PIN |

4.3 Evaluation Board Fuse Replacement

The Evaluation Board is protected by a 2 ampere fuse. The fuse can be blown by an over-current condition caused by an internal failure or over-voltage. Follow the procedure below to remove and replace the fuse:

1. Disconnect the primary power cable and all other connections to the Evaluation Board.
2. Locate the fuse holder assembly, FH1, behind the green power connector, J3.
3. Loosen the fuse from the holder using a very small screwdriver, then use a small pair of needle-nose pliers to pull the fuse straight up and out of the holder.
4. Use an ohmmeter or other continuity tester to verify that the fuse is open.
5. Install a new fuse in the holder. Replacement fuse information: Littelfuse #0454002; 452 Series, 2 Amp SMF Slo-Blo fuse (MDS Part No. 29-1784A03).



5.0 TRANSCEIVER MOUNTING

This section provides information for mounting the OEM transceiver in a host device. The module need only be protected from direct exposure to the weather. No additional RF shielding is required.

5.1 Mounting Dimensions

Figure 15 shows the dimensions of the transceiver board and its mounting holes. If possible, choose a mounting location that provides an unobstructed view of the radio's LED status indicators when viewing the board from outside the host device.

Mount the transceiver module to a stable surface using the four mounting holes at the corners of the PC board. Standoff spacers should be used to maintain adequate clearance between the bottom of the circuit board and the mounting surface. (Fasteners/anchors are not normally supplied.)

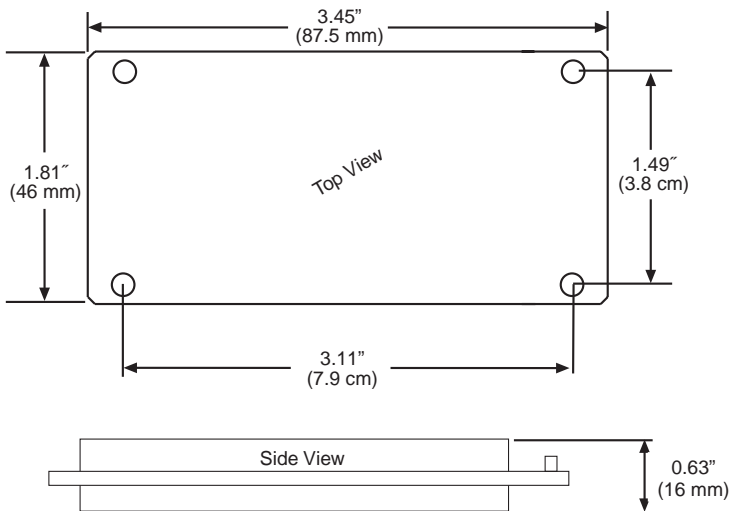

Figure 15. Transceiver Mounting Dimensions

5.2 Antennas & Feedlines

A number of omnidirectional and directional antennas are available for use with the radio. Contact your factory representative for specific recommendations on antenna types and hardware sources. In general, an omnidirectional antenna (Figure 16) is used at master station sites in order to provide equal coverage to all of the remote units.



At remote sites and in many point-to-point systems, a directional Yagi antenna (Figure 17) is generally recommended to minimize interference to and from other users and to maximize range.

For systems operating in a very short range environment, small, flexible whip antennas may also be supplied. Such antennas are available for direct connection to the transceiver module, or for exterior mounting with various lengths of feedline.

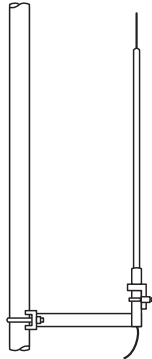

Figure 16.
Omnidirectional Antenna
(shown mounted to mast)

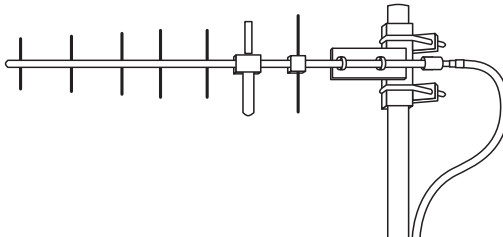

Figure 17. Typical Yagi Antenna (shown mounted to mast)

Feedlines

The feedline supplied with the antenna was carefully selected to minimize RF loss and ensure regulatory compliance with the antenna being used. Do not make substitutions or change the lengths of the antenna system feedline. If you require a different length of feedline for your installation, contact your factory representative for assistance.

NOTE: Strong fields near the antenna can interfere with the operation of the low level RTU circuits and change the reported values of the data being monitored. If interference is experienced, it may be necessary to re-orient the antenna with respect to the radio, RTU, sensors or other components of the system.



6.0 EIRP Compliance Check

IMPORTANT: To comply with FCC and Industry Canada rules, the effective isotropic radiated power (EIRP) of an OEM transceiver installation must not exceed 36 dBm.

Transceiver modules are shipped from the factory with an RF output setting of +27 dBm. This setting is password-controlled and may not be changed by unauthorized persons. This power level provides EIRP compliance when the module is used with many types of antennas, however, each installation must be carefully evaluated to ensure compliance. The formula for determining EIRP is as follows:

Transmitter RF output power (dBm) + Antenna gain (dBi) – Feedline loss (dB)

Table 7 shows three types of antennas and their associated gains. Note that for a 10 dBi gain antenna, the system must include at least 1 dB of feedline loss to achieve EIRP compliance. Higher gain antennas would require additional feedline loss in order to limit the EIRP to a maximum of 36 dBm.

If no feedline is used (directly connected antenna), with an antenna gain exceeding 9 dBi, it will be necessary to reduce the transmitter output power to less than +27 dBm. Contact MDS for further information. *In no case shall the station's EIRP exceed 36 dBm.*

Table 7. Antenna System Gain vs. EIRP

| Antenna Type (Model No.) | Gain (dBi) | Transmitter Power Setting (dBm) | EIRP (dBm) |
|---|---------------|---------------------------------------|---------------|
| 1/2 Wave Whip Dipole (MHWS2400MSMA) | 2 | +27 | 29 |
| Omni-directional Base Station (MFB24010) | 10* | +27 | 37* |
| Yagi Directional (MYP24010PT) | 10* | +27 | 37* |

* These antenna systems must include a feedline loss of at least 1 dB to maintain compliance with the EIRP limit of 36 dBm.

7.0 OPTIMIZING PERFORMANCE

After the basic operation of the radio has been checked, you may wish to optimize its performance using some of the suggestions given here. The effectiveness of these techniques will vary with the design of your system and the format of the data being sent.

Complete instructions for using the commands referenced in this manual are provided in “[PROGRAMMING REFERENCE](#)” on Page 34.



7.1 Antenna Aiming

For optimum performance of directional antennas (yagis), they must be accurately aimed in the direction of desired transmission. The easiest way to do this is to point the antenna in the approximate direction, then use the remote radio's **RSSI** command (Received Signal Strength Indicator) to further refine the heading for maximum received signal strength.

In an MAS system, RSSI readings are only meaningful when initiated from a remote station. This is because the master station typically receives signals from several remote sites, and the RSSI would be continually changing as the master receives from each remote in turn.

7.2 Antenna SWR Check

It is necessary to briefly key the transmitter for this check by placing the radio in the **SETUP** mode (Page 49) and using the **KEY** command. (To unkey the radio, enter **DKEY**; to disable the **SETUP** mode and return the radio to normal operation, enter **Q** or **QUIT**.)

The SWR of the antenna system should be checked before the radio is put into regular service. For accurate readings, a wattmeter suited for 2.4 GHz is required. One unit meeting this criteria is the Bird Model 43 directional wattmeter with an appropriate element installed.

The reflected power should be less than 10% of the forward power ($\approx 2:1$ SWR). Higher readings usually indicate problems with the antenna, feedline or coaxial connectors.

7.3 Data Buffer Setting

The default setting for the data buffer is **OFF**. This allows the radio to operate with the lowest possible latency and improves channel efficiency. MODBUS and its derivatives are the only protocols that should require the buffer to be turned on. See “**BUFF [ON, OFF]**” on Page 42 for details.

7.4 Hoptime Setting

The default hop-time setting is **7** (7 ms). An alternate setting of **28** is used to increase throughput, but at the cost of increased latency. A detailed explanation of the **HOPTIME** command can be found on Page 44.

7.5 Operation at 115200 bps

Burst throughput at 115200 bps is supported at all settings. The radio will always buffer at least 500 characters. Sustained throughput at 115200bps is only possible when the data path is nearly error free and the operating settings have been properly selected. For sustained operation at 115200 bps, use the following settings: **SAF OFF, FEC OFF, REPEAT 0, RETRY 0, HOPTIME 28**.



7.6 Baud Rate Setting

The default baud rate setting is 19200 bps to accommodate most systems. If your system will use a different data rate, you should change the radio's data interface speed using the **BAUD xxxxx abc** command (Page 42). It should be set to the highest speed that can be sent by the data equipment in the system. (The transceiver supports 1200 to 115200 bps.)

7.7 Radio Interference Checks

The radio operates in eight frequency zones. If interference is found in one or more of these zones, the **SKIP** command (Page 49) can be used to omit them from the hop pattern. You should also review *8.0 DEALING WITH INTERFERENCE*, when interference problems are encountered.

8.0 OPERATING PRINCIPLES & SPECIAL CONFIGURATIONS

8.1 How Remotes Acquire Synchronization

Remotes acquire synchronization and configuration information via **SYNC** messages sent from the Master (the **MODE M** unit) or from any valid Extension (**MODE X** unit).

The Master will always transmit **SYNC** messages. An Extension will only start sending **SYNC** messages after synchronization is achieved with its Master.

The ability to synchronize to a given radio is further qualified by the sender's Extended Address (**XADDR**) and by receiver's Synchronization Qualifiers (**XMAP**, **XPRI**, and **XRSSI**).

When a primary is specified (**XPRI** is 0...31), a radio will always attempt to find the primary first. If 30 seconds elapses and the primary is not found, then the radio will attempt to synchronize with any non-primary radio in the **XMAP** list.

Once every 30 minutes, if a primary is defined, the radio will check its synchronization source. If the radio is synchronized to a unit other than the primary, then the current **RSSI** value is compared to the **XRSSI** value. If **RSSI** is less than **XRSSI** (or if **XRSSI** is **NONE**) the radio will force a loss-of-synchronization, and hunt for the primary again (as described in the previous paragraph).

By default, Extensions (and the Master) begin with **XADDR 0**. Synchronization qualifiers are set to **XMAP 0**, **XPRI 0**, and **XRSSI NONE**, respectively. This default configuration allows any radio to hear the Master. When an Extension is added, the extended address of *the Extension must be set to a unique value*. All remotes that need to hear that extension can specify this either by designating the extension as the primary (**XPRI**), or by including it in their list of valid synchronization sources (**XMAP**).



8.2 Establishing a Tail-End Link

A tail-end link can be used to bring an outlying remote site into the rest of an MAS network. Figure 5 on Page 5 shows a diagram of this type of system.

A tail-end link is established by connecting an OEM transceiver “back-to-back” with another unit such as a licensed MDS x710 Series transceiver. The wiring connections between the two radios must be made as shown in Figure 18. In addition, the **DEVICE CTS KEY** command must be asserted at the OEM radio.

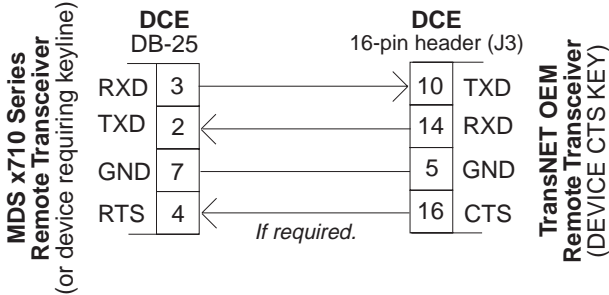

Figure 18. Data Crossover Cable for Tail-End Links

8.3 Store & Forward (SAF) Operation with Extension Radios

The Store-and-Forward (SAF) capability allows individual radios to act as data repeaters. SAF operates by dividing a network into a vertical hierarchy of two or more sub-networks. (See Figure 6 on Page 6.) Adjacent sub-networks are connected via Extension radios operating in “**MODE X**” which move data from one sub-network to the next one.

The Store-and-Forward implementation adheres to the general polling principles used in most multiple-address systems (MAS). Polls originate from the Master station, broadcast to *all* radios within the network, and travel hierarchically downward. All Remotes will hear the same message, but only one Remote will respond. Messages within a hierarchy only travel in one direction at a time.

Using SAF will cut the overall data throughput in half, however, multiple networks can be inter-connected with no additional loss in network throughput.



Simple Extended SAF Network

Figure 19 depicts a two-level network utilizing a single Master (M) and an Extension (X) radio. In this network, messages directed to Remotes in the “K” sub-network, will be relayed through Extension radio $X_{j,k}$ to the K-Remotes. Any response from a Remote in sub-network “K” will pass back through Extension radio $X_{j,k}$ to the Master M_j . Radios in sub-network “J” operate on the same set of frequencies and sub-network “K” but with a different radio-frequency hopping pattern.

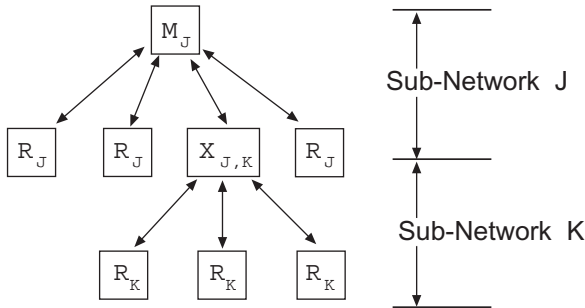

Figure 19. Simple Extended SAF Network
Networks: J and K

In the SAF operation, the Extension radios are set to **MODE X** (*Details page 45*) and operate with a “dual personality”—50% of the time they serve as a Remote station and 50% of the time as a Master for sub-network Remotes.

Extended SAF Network

Below is an example of a multilevel network utilizing two repeaters— $X_{J,K}$ and $X_{K,L}$. The example demonstrates the extensibility of the network. In this case, messages directed to Remotes in the sub-network L will be relayed through Extension radios $X_{J,K}$ and $X_{K,L}$. As in the previous example, the Extension radios will split their operating time equally between their Master and Remote personalities. This multi-layered network can be extended indefinitely without degrading system throughput beyond that initially incurred by placing the network in the SAF mode.

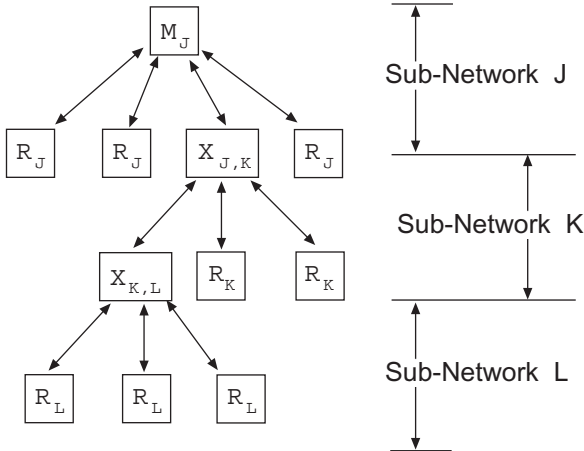

Figure 20. Extended SAF Network
Networks: J, K, L

Retransmission and ARQ operation

Functionally, the sub-network side of an Extension behaves like a corresponding connection between a master and a remote.

When an Extension is using its “master personality” it sends acknowledgments and performs unconditional retransmissions based on its **REPEAT** count.

When an Extension is using its “Remote personality”, acknowledgments are processed and retransmissions occur as needed, up to the number of times specified by the **RETRY** count value.

If new data arrives—from a new source—prior to completion of retransmissions, then this is considered a violation of the polling model protocol. The new data takes precedence over the old data and the old data is lost. In such a situation, new data is likely to be corrupt as it will have some old data mixed in with it.

Synchronization in SAF Networks

The Master controls the synchronization for a given network for all modes. Setting the Master to “**SAF ON**” broadcasts a command from the Master to all radio units in the associated network either directly or through an Extension radio. This command puts *all radios in the entire system* in a special time-division duplexing mode that alternates between two timeslots. One time slot for data communications upstream and another for downstream communications.



The Extensions are single radios which serve as bridges between adjacent sub-network levels. Extensions will undertake a “remote” personality in one timeslot, and a “master” personality in the alternate timeslot and provide communications with associated Remotes downstream. Extensions behave like two radios with their data ports tied together, first synchronizing with their upstream Master during their Remote personality period, and then providing synchronization signals to dependent Remotes downstream during its Master personality period.

All Remotes synchronize to a corresponding Master. This can be the “real master” (the **MODE M** unit), or it can be a repeater “Extension” that derives synchronization from the “real master.”

Payload polls/packets broadcast from the network Master will be repeated to all levels of the network, either directly to Remotes, or through network repeaters—the Extensions station. The targeted Remote will respond to the poll following the same path back to the Master.

Configuration Parameters for Store-and Forward Services

The installation and configuration of a network with an Extension using SAF is straight-forward with only a few unique parameters that need to be considered and set at each unit.

In every network there can be only one Master station. It will serve as the sole gateway to the outside world. The following three tables detail the parameters that will need to be set on each type of radio in the network.

- Network Master Radio—[Table 8 on Page 29](#)
- Extension Radio(s)—[Table 9 on Page 30](#)
- Remote Radio(s)—[Table 10 on Page 31](#)

**Table 8. Configuration Parameters for SAF Services
Network Master Radio**

| Parameter | Command | Description |
|-----------------|---|--|
| Operating Mode | MODE M <i>Details page 45</i> | Set the radio to serve as a Master |
| Network Address | ADDR <i>Details page 40</i> | A number between 1 and 65,000 that will serve as a common network address. All radios in the network use the same number. |



**Table 8. Configuration Parameters for SAF Services
Network Master Radio (Continued)**

| Parameter | Command | Description |
|------------------------|---|---|
| Extended Address | XADDR <i>Details page 51</i> | A number between 0 and 31 that will serve as a common address for radios that synchronize directly to this master. Typically, the Master is set to zero (0). |
| Store and Forward Mode | SAF ON <i>Details page 49</i> | Enables store and forward capability in the network. |

**Table 9. Configuration Parameters for SAF Services
Extension Radio(s)**

| Parameter | Command | Description |
|--|---|---|
| Operating Mode | MODE X <i>Details page 45</i> | Set the radio to serve as an Extension |
| Network Address | ADDR <i>Details page 40</i> | A number between 1 and 65,000 that will serve as a common network address. All radios in the network use the same number. |
| Extended Address | XADDR <i>Details page 51</i> | A number between 0 and 31 that will serve as a common address for radios that synchronize directly to this Extension radio serving as master for associated sub-network units. We recommend using zero (0) for the Master station. |
| Primary Extended Address | XPRI <i>Details page 51</i> | XADDR number of the primary or preferred radio with which this radio will synchronize. |
| Extension Map | XMAP <i>Details page 51</i> | Functional list of all XADDR values with which this radio can synchronize, excluding the XPRI address |
| Extension Received Signal Strength Indicator | XRSSI <i>Details page 51</i> | The minimum RSSI level required to preserve synchronization with a non-primary radio. (Ineffective when XPRI is NONE) |



**Table 10. Configuration Parameters for SAF Services
Remote Radio(s)**

| Parameter | Command | Description |
|---|---|--|
| Operating Mode | MODE R <i>Details page 45</i> | Set the radio to serve as a Remote station |
| Network Address | ADDR <i>Details page 40</i> | A number between 1 and 65,000 that will serve as a common network address or name. Same number for all units in the same network. |
| Primary Extended Address | XPRI <i>Details page 51</i> | XADDR number of the primary or preferred radio with which this radio will synchronize. |
| Extension Map | XMAP <i>Details page 51</i> | A list of all XADDR values with which this radio can synchronize, excluding the XPRI address |
| Extension Received Signal Strength Indicator | XRSSI <i>Details page 51</i> | The minimum RSSI level required to preserve synchronization with a non-primary radio. (Ineffective when XPRI is NONE) |

8.4 Sleep Mode Operation (*Remote units only*)

In some installations, such as at solar-powered sites, it may be necessary to keep the transceiver's power consumption to an absolute minimum. This can be accomplished using the radio's Sleep Mode feature. In this mode, power consumption is reduced to about 8 mA.

Sleep Mode can be enabled under RTU control by asserting a ground (on Pin 6 of J3, the radio's header connector). The radio stays in Sleep Mode until the low is removed, and all normal functions are suspended.

The radio can be "awakened" by your RTU every minute or so to verify synchronization with the master station. When the ground is removed, the radio will be ready to receive data within 75 milliseconds.

NOTE: The **SLEEP** function must be set to **ON**; otherwise a ground on the Sleep Mode pin will be ignored.



It is important to note that power consumption will increase somewhat as communication from the master station degrades. This is because the radio will spend a greater period of time “awake” looking for synchronization messages from the master radio.

In order for the radio to be controlled by the Sleep Mode pin, the radio must be set to **SLEEP ON**. See “**SLEEP [ON, OFF]**” on Page 50 for more information.

Sleep Mode Example

The following example describes Sleep Mode implementation in a typical system. Using this information, you should be able to configure a system that meets your own particular needs.

Suppose you need communications to each remote site only once per hour. Program the RTU to raise an EIA/RS-232 line once each hour (DTR for example) and wait for a poll and response before lowering it again. Connect this line to Pin 6 of the radio’s header connector. This will allow each RTU to be polled once per hour, with a significant savings in power consumption.

9.0 DEALING WITH INTERFERENCE

The transceiver shares the frequency spectrum with other services and other Part 15 (unlicensed) devices in the USA. As such, near 100% error free communications may not be achieved in a given location, and some level of interference should be expected. However, the radio’s flexible design and hopping techniques should allow adequate performance as long as care is taken in choosing a suitable location and in configuring the radio’s operating parameters.

In general, keep the following points in mind when setting up your communications network:

1. Systems installed in rural areas are least likely to encounter interference; those in suburban and urban environments are more likely to be affected by other devices operating in the license-free frequency band and by adjacent licensed services.
2. If possible, use a directional antenna at remote sites. They confine the transmission and reception pattern to a narrow lobe, which minimizes interference to (and from) stations located outside the pattern.
3. If interference is suspected from a nearby licensed system (such as a paging transmitter), it may be helpful to use horizontal polarization of all antennas in the network. Because most other services typically use vertical polarization in this band, an additional 20 dB of attenuation to interference can be achieved by using the horizontal plane.
4. Multiple spread spectrum systems can co-exist in close proximity to each other with only minor interference, provided they are each assigned a unique network address. Each network address has a different hop pattern associated with it.