

MDS TransNET OEM™

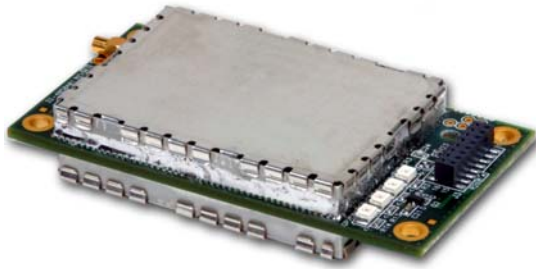

Transceiver Model EL806

Spread Spectrum Data Transceiver

*Including Instructions for
03-4053A01 Evaluation Development Kit*

05-3946A01, Rev. C
JUNE 2007



GE MDS
industrial wireless networks

QUICK START GUIDE

The steps below contain the essential information needed to place the OEM transceiver in service. Because the transceiver is designed for use in other pieces of equipment, these steps assume that prior testing and evaluation have been conducted with the host device. If not, please refer to “[EVALUATION DEVELOPMENT KIT \(P/N 03-4053A01\)](#)” on [Page 75](#) for interface wiring and configuration details.

1. Mount the transceiver module using the four holes provided.

- If possible, select a mounting location that allows viewing the status LEDs and provides ready access to the antenna connector.
- Use standoff hardware to secure the board to the host device.
- When mounting the board, use care to align the transceiver’s 16-pin header connector with the mating pins in the host device.

2. Connect the antenna system to the transceiver

- Use only with antenna/feedline assemblies that have been expressly tested and approved for such service by GE MDS.
- Use a matching connector to attach the antenna to the transceiver.
- For best performance, antennas should be mounted in the clear, with an unobstructed path in the direction of desired transmission/reception.

3. Apply power and observe the LEDs for proper operation. The LED command must be set to ON (LEDS ON).

After 16 seconds...

- The GP LED should be lit continuously
- The DCD LED should be lit continuously—if synchronization with another unit has been achieved
- The Remote radio(s) should be transmitting data (TXD) and receiving data (RXD) with its associated station

LED Indicator Descriptions

	LED Name	Description
RXD	RXD (CR3) Receive Data	Serial receive data activity. Payload data from connected device.
TXD	TXD (CR4) Transmit Data	Serial transmit data activity. Payload data to connected device.
DCD	DCD (CR5) Data Carrier Detect	Continuous—Radio is receiving/sending synchronization frames
GP	GP (CR6) General Purpose	On within 10 seconds of power-up under normal conditions
		• Continuous—Power is applied to the radio; no problems detected
		• Flashing (5 times-per-second)—Fault indication. See “ TROUBLESHOOTING ” on Page 59
		• Off—Radio is unpowered or in Sleep mode

CONTENTS

1.0 ABOUT THIS MANUAL	1
2.0 PRODUCT DESCRIPTION	1
2.1 Transceiver Features	2
2.2 Factory Hardware Options	2
2.3 Data Interface and Power (J3) Options	2
Antenna Connector (J200/J201).....	3
2.4 Model Number	3
2.5 Spread Spectrum Radios—How Are They Different?	4
2.6 Typical Applications	4
Multiple Address Systems (MAS)	4
Point-to-Point System.....	5
Tail-End Link to an Existing Network	5
Store-and-Forward Repeater	6
2.7 Transceiver Accessories	6
3.0 BENCHTOP SETUP & EVALUATION	7
3.1 Initial Power-Up & Configuration	8
Configuration Settings.....	8
Configuring Multiple Remote Units.....	9
3.2 Tail-End Links	9
3.3 Configuring a Network for Extensions	10
3.4 LED Indicators	10
4.0 TRANSCEIVER MOUNTING.....	11
4.1 Antenna & Feedline Selection	13
Antennas.....	13
Feedlines.....	14
Antenna System Ground	15
5.0 PERFORMANCE OPTIMIZATION.....	15
Antenna Aiming	16
Antenna SWR Check.....	16



- Data Buffer Setting—MODBUS™ Protocol 16
- Hoptime Setting 16
- TotalFlow™ Protocol at 9600 with Sleep Mode 17
- Operation at 115200 bps 17
- Baud Rate Setting 17
- Radio Interference Checks..... 17
- 5.1 How Much Output Power Can be Used? 17
- 6.0 OPERATING PRINCIPLES & SPECIAL CONFIGURATIONS 19

- 6.1 Synchronizing Network Units 19
 - Synchronization Messages 19
- 6.2 Establishing a Tail-End Link 20
- 6.3 SAF Operation with Extension Radios 21
 - Simple Extended SAF Network 21
 - Extended SAF Network..... 22
 - Retransmission and ARQ Operation 22
 - SAF Configuration Example 23
- 6.4 Using AT Commands 23
 - Supported AT Commands..... 24
 - Operating Notes when AT Commands are ON 25
- 6.5 Configuration Parameters for Store & Forward Services 25
- 6.6 Using the Radio’s Sleep Mode (Remote Units Only) 27
 - Sleep Mode Example..... 28
- 6.7 Low-Power Mode (LPM)—Master Enabled 28
 - Setup Commands..... 28
 - Reading RSSI & Other Parameters with LPM Enabled..... 29
 - Power Consumption Influence by HOPTIME and SAF Settings..... 29
- 6.8 Low-Power Mode versus Remote’s Sleep Mode 30
 - Introduction 30
 - Operational Influences—Hoptime and SAF..... 31
 - Master Station Configuration 32
 - Antenna System for Co-Located Master Stations 32
- 7.0 DEALING WITH INTERFERENCE 33

- Terminal Interface..... 34
- PC-Based Configuration Tool 35
- 8.2 User Commands 35

Entering Commands	35
8.3 Detailed Command Descriptions	41
ADDR [1–65000]	41
AMASK [0000 0000–FFFF FFFF]	42
AT [ON, OFF]	42
ASENSE [HI/LO].....	42
BAUD [xxxxx abc]	42
BAND [A, B, C].....	43
BUFF [ON, OFF]	43
CODE [NONE, 1... 255]	43
CSADDR [1–65000, NONE]	44
CTS [0–255]	44
CTSHOLD [0–60000].....	44
DEVICE [DCE, CTS KEY]	45
DLINK [xxxxx/ON/OFF].....	45
DKEY	45
DTYPE [NODE/ROOT]	46
FEC [ON, OFF]	46
HOPTIME [7, 28].....	46
INIT	46
HREV	48
KEY	48
LED [ON, OFF]	48
LPM [1, 0]	48
LPMHOLD [0–1000]	49
MODE [M, R, X]	49
MRSSI [NONE, –40...–90]	49
OT [ON, OFF]	50
OWM [xxxxx]	50
OWN [xxxxx].....	50
PORT [RS232, RS485].....	50
PWR [20–30].....	50
REPEAT [0–10].....	51
RETRY [0–10]	51
RSSI.....	51
RTU [ON, OFF, 0-80]	52
RX [xxxx].....	52
RXD [0–255].....	52
RXTOT [NONE, 0–1440].....	52



SAF [ON, OFF] 53

SETUP 53

SER 53

SHOW CON 53

SHOW PWR 54

SHOW SYNC 54

SKIP [NONE, 1..8] 54

SLEEP [ON, OFF] 55

SREV 55

STAT 55

TEMP 56

TX [xxxx] 56

UNIT [10000–65000] 56

XADDR [0–31] 56

XMAP [00000000-FFFFFFFF] 56

XPRI [0–31] 57

XRSSI [NONE, –40...–120] 57

ZONE CLEAR 57

ZONE DATA 57

Checking for Alarms—STAT command 58

Major Alarms versus Minor Alarms 59

Alarm Codes’ Definitions 59

9.2 LED Indicators 60

9.3 Troubleshooting Chart 61

 Saving a Web-Site Firmware File Onto Your PC 63

 Using the I/O Points with InSite™ NMS Software 73

 Application Example—Digital Input/Output at Remote 73

 Evaluation PC Board 74

 Connecting the Transceiver & Evaluation Board 75

 Antenna Connection—Transceiver Module, J200/201 76

 DC Power Connector, J3 77

 Diagnostic Connection, J4 77

 DATA Connector, J5 78

 Transceiver Power Interface, J1 80

 Assembly Drawing 81

 Parts List 81

 Evaluation PCB Interface to Transceiver PCB, J2 83

 PCB Schematic 83

To Our Customers

We appreciate your patronage. You are our business. We promise to serve and anticipate your needs. We strive to give you solutions that are cost effective, innovative, reliable and of the highest quality possible. We promise to build a relationship that is forthright and ethical, one that builds confidence and trust. We are committed to the continuous improvement of all of our systems and processes, to improve product quality and increase customer satisfaction.

Copyright Notice

This Installation and Operation Guide and all software described herein are Copyright 2007 by GE MDS, LLC. All rights reserved. The company reserves its right to correct any errors and omissions in this manual.

RF Exposure Notice

RF EXPOSURE Professional installation required. The radio equipment described in this guide emits radio frequency energy. Although the power level is low, the concentrated energy from a directional antenna may pose a health hazard. Do not allow people to come closer than 23 cm (9 inches) to the antenna when the transmitter is operating in indoor or outdoor environments.



In mobile applications (vehicle mounted) the above separation distance must be maintained at all times. More information on RF exposure is available on the Internet at www.fcc.gov/oet/info/documents/bulletins.

L'énergie concentrée en provenance d'une antenne directionnelle peut présenter un danger pour la santé. Ne pas permettre aux gens de s'approcher à moins de 23 cm à l'avant de l'antenne lorsque l'émetteur est en opération. On doit augmenter la distance proportionnellement si on utilise des antennes ayant un gain plus élevé. Ce guide est destiné à être utilisé par un installateur professionnel. Plus d'informations sur l'exposition aux rayons RF peut être consulté en ligne à l'adresse suiv-ante: www.fcc.gov/oet/info/documents/bulletins

ISO 9001 Registration

GE MDS adheres to the internationally-accepted ISO 9001 quality system standard.

FCC Part 15 and Industry Canada RSS Notice

This device complies with Part 15 of the FCC Rules and Industry Canada license-exempt RSS standard(s). Operation is subject to the following two conditions: (1) this device may not cause interference, and (2) this device must accept any interference that may cause undesired operation of the device.

a) Under Industry Canada regulations, this radio transmitter may only operate using an antenna of a type and maximum (or lesser) gain approved for the transmitter by Industry Canada. To reduce potential radio interference to other users, the antenna type and its gain should be so chosen that the equivalent isotropically radiated power (e.i.r.p.) is not more than that necessary for successful communication.

b) The radio transmitter described herein (IC ID: 3738A-MDSEL806) is approved by Industry Canada to operate with the antenna types listed below with the maximum per-missible gain and required antenna impedance for each antenna type indicated. Antenna types not included in this list, having a gain greater than the maximum gain indicated for that type, are strictly prohibited for use with this device.

Warning: Changes or modifications not expressly approved by the manufacturer could void the user's authority to operate the equipment.

Cet appareil est conforme à la Partie 15 des règlements de la FCC et Industrie Canada exempts de licence standard RSS (s). Son utilisation est soumise à deux conditions: (1) ce dispositif ne peut causer des interférences, (2) cet appareil doit accepter toute interférence pouvant causer un mauvais fonctionnement du dispositif.

a) En vertu des règlements d'Industrie Canada, cet émetteur radio ne peut fonctionner avec une antenne d'un type et un maximum (ou moins) approuvés pour gagner de l'émetteur par Industrie Canada. Pour réduire le risque d'interférence aux autres utilisateurs, le type d'antenne et son gain doivent être choisis de façon que la puissance isotrope rayonnée équivalente (PIRE) ne dépasse pas ce qui est nécessaire pour une communication réussie.

b) L'émetteur radio décrit ci-après (IC ID: 3738A-MDSEL806) a été approuvé par Industrie Canada pour fonctionner avec les types d'antennes énumérées ci-dessous avec le gain maximal admissible et nécessaire antenne d'impédance pour chaque type d'antenne indiqué. Types d'antennes ne figurent pas dans cette liste, ayant un gain supérieur au gain maximum indiqué pour ce type, sont strictement interdites pour une utilisation avec cet appareil.

Antenna Gain/Power Data (FCC)

Antenna System Gain (Antenna Gain in dBi^a minus Feedline Loss in dB^b)	Maximum Power Setting (in dBm)	EIRP (in dBm)
6 (or less)	30	36
8	28	36
10	26	36
12	24	36
14	22	36
16	20	36

- a. Most antenna manufacturers rate antenna gain in dBd. To convert to dBi, add 2.15 dB.
- b. Feedline loss varies by cable type and length. Consult manufacturer data.

Antenna Gain/Power Data (Industry Canada)

Antenna System Gain (Antenna Gain in dBi ^a minus Feedline Loss in dB ^b)	Maximum Power Setting (in dBm)	EIRP (in dBm)
0 dBi Dipole	28.5	36
2 dBi Dipole	28.5	36
7.1 dB Omni	28.5	36
8.5 dBi Yagi	27	36

- a. Most antenna manufacturers rate antenna gain in dBd. To convert to dBi, add 2.15 dB.
- b. Feedline loss varies by cable type and length. Consult manufacturer data.

FCC Limited Modular Approval

This device is offered as an FCC Part 15 Unlicensed *Limited Modular Transmitter (LMA)*. The transmitter module is approved for use only with specific antenna, cable and output power configurations that have been tested and approved for use when installed in devices approved by third-party OEMs, or produced by the Grantee (GE MDS). Modifications to the radio, the antenna system, or power output, that have not been explicitly specified by the manufacturer are not permitted, and may render the radio non-compliant with applicable regulatory authorities. Refer to [Table 10 on Page 28](#) for more detailed information.

When this device is placed inside an enclosure, a durable label must be affixed to the outside of that enclosure indicating the unit’s FCC ID Number.

The antenna(s) to be used with this module must be installed with consideration to the guidelines for RF exposure risk to all nearby personnel, and must not be co-located or operating in conjunction with any other antenna or transmitter.

Changes or modifications not expressly approved by the party responsible for compliance could void the user’s authority to operate the equipment.

UL Notice

The MDS TransNET OEM 900 (Model EL806) and TransNET OEM 2400 (Model EL806-24) is available for use in Class I, Division 2, Groups A, B, C & D Hazardous Locations. Such locations are defined in Article 500 of the National Fire Protection Association (NFPA) publication NFPA 70, otherwise known as the National Electrical Code.



Both transceivers models have been recognized for use in these hazardous locations by the Canadian Standards Association (CSA). The transceiver is as a Recognized Component for use in these hazardous locations, in accordance with CSA STD C22.2 No. 213-M1987.

UL Conditions of Approval:

The transceiver is not acceptable as a stand-alone unit for use in the hazardous locations described above. It must either be mounted within another piece of equipment which is certified for hazardous locations, or installed within guidelines, or conditions of approval, as set forth by the approving agencies. These conditions of approval are as follows:

1. The transceiver must be mounted within a separate enclosure which is suitable for the intended application.
2. The coaxial antenna cable, power input cable and interface cables must be routed through conduit in accordance with Division 2 wiring methods as specified in the National Electrical Code, Article 501.4(B).
3. The transceiver must be used within its Recognized “Ratings”.
4. Installation, operation and maintenance of the transceiver should be in accordance with the transceiver's installation manual, and the National Electrical Code.
5. Tampering or replacement with non-factory components may adversely affect the safe use of the transceiver in hazardous locations, and may void the approval.
6. A power connector with screw-type retaining screws as supplied by GE MDS must be used.

When installed in a Class I, Div. 2, Groups A, B, C or D hazardous location, observe the following:

WARNING — EXPLOSION HAZARD

Do not disconnect equipment unless power has been switched off or the area is known to be non-hazardous.

Substitution of components may impair suitability for Class 1, Division 2.

Refer to Articles 500 through 502 of the National Electrical Code (NFPA 70) for further information on hazardous locations and approved Division 2 wiring methods.

ESD Notice



CAUTION
ELECTROSTATIC DISCHARGE

To prevent malfunction or damage to this radio, which may be caused by Electrostatic Discharge (ESD), the radio should be properly grounded by connection to the ground stud on the rear panel. In addition, the installer or operator should follow proper ESD precautions, such as touching a grounded bare metal object to dissipate body charge, prior to adjusting front panel controls or connecting or disconnecting cables on the front or rear panels.

Environmental Information



The equipment that you purchased has required the extraction and use of natural resources for its production. Improper disposal may contaminate the environment and present a health risk due to hazardous substances contained within. To avoid dissemination of these substances into our environment, and to diminish the demand on natural resources, we encourage you to use the appropriate recycling systems for disposal. These systems will reuse or recycle most of the materials found in this equipment in a sound way. Please contact GE MDS or your supplier for more information on the proper disposal of this equipment.

Manual Revision and Accuracy

While every reasonable effort has been made to ensure the accuracy of this manual, product improvements may result in minor differences between the manual and the product shipped to you. If you have additional questions or need an exact specification for a product, please contact our Customer Service Team using the information at the back of this guide. In addition, manual updates can often be found on the GE MDS Web site at www.GEmds.com.

1.0 ABOUT THIS MANUAL

This manual is intended to guide technical personnel in the integration of MDS TransNET OEM™ transceivers into existing electronic equipment. The OEM transceiver is designed for use inside Remote Terminal Units (RTUs), Programmable Logic Controllers (PLCs) and other equipment associated with remote data collection, telemetry and control.

The manual provides instructions for interface connections, hardware mounting, and programming commands. Following integration of the transceiver, it is recommended that a copy of this manual be retained for future reference by technical personnel.

2.0 PRODUCT DESCRIPTION

The OEM transceiver, (Figure 1), is a compact, spread spectrum wireless module designed for operation in the 900 and 2400 MHz license-free frequency bands. It is contained on one double-sided circuit board with all necessary components and RF shielding included. It need only be protected from direct exposure to the weather and is designed for rugged service in extreme temperature environments.

The transceiver has full over-the-air compatibility with standard (non-OEM) TransNET transceivers manufactured by GE MDS. All transceiver programming is performed via a personal computer or terminal connected to the module. There are no manual adjustments required to configure the transceiver for operation.

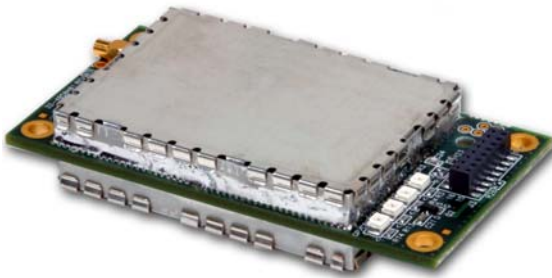

Figure 1. TransNET OEM™ Transceiver

The transceiver employs Digital Signal Processing (DSP) technology for highly-reliable data communications, even in the presence of weak or interfering signals. DSP techniques also make it possible to obtain information about the radio's operation and troubleshoot problems, often eliminating the need for site visits.

Using appropriate software at the master station, diagnostic data can be retrieved for any radio in the system, even while payload data is being transmitted. (See “Performing Network-Wide Remote Diagnostics” on Page 61.)

2.1 Transceiver Features

The OEM transceiver is designed for easy installation and flexibility in a wide range of wireless applications. Listed below are several key features of the transceiver which are described in more detail later in this guide.

- 902–928 MHz operation using the TransNET OEM 900
- 2400–2482 MHz operation using the TransNET OEM 2400
- User-selectable option to skip sub-bands with constant interference
- 65,000 available network addresses
- Network-wide configuration from the Master station eliminates most trips to Remote sites
- Data transparency ensures compatibility with virtually all asynchronous SCADA system RTUs
- Peak-hold RSSI averaged over eight hop cycles
- Operation at up to 115,200 bps continuous data flow
- Store-and-Forward repeater operation
- Data latency typically less than 10 ms
- Same hardware for Master or Remote configuration
- Supports RS/EIA-232 and RS/EIA-485 user interface
- Low current consumption; typically less than 3 mA in “sleep” mode

NOTE: Some radio features may not be available on all models, or limited by the options purchased, or the applicable regulatory constraints for the region in which the radio will operate.

2.2 Factory Hardware Options

There are a number options for the transceiver assembly that must be specified at the time the order. These include: antenna connector type, data interface signalling and primary power.

2.3 Data Interface and Power (J3) Options

Table 1 below lists the interface options that can be specified when the transceiver module is ordered. If you are uncertain as to the configuration of the unit you are using, please copy the model number code from the transceiver module and contact the GE MDS Customer Service Department for assistance.

Table 1. Data Interface & Power Options
(Factory Configurable Only)

PAYLOAD DATA	DIAGNOSTICS DATA	INPUT POWER
RS-232/485	RS-232	+6–30 Vdc
TTL	RS-232	+6–30 Vdc
TTL	TTL	+6–30 Vdc

Antenna Connector (J200/J201)

The PCB has solder pads for several RF connectors with different footprints but only one RF connector will be installed. Below is a table of connector options available from the factory when the order is placed. We do not recommend retrofitting the PCB with an alternate connector as damage to the board could result and will void the factory warranty.

Table 2. Antenna Connector Options

Connector Description
MMCX, JACK, RIGHT ANGLE
MCX, JACK, RIGHT ANGLE
MCX, STRAIGHT JACK RECEPTACLE
MCX, STRAIGHT PLUG RECEPTACLE
SMB, CON, COAX SMB RIGHT ANGLE
SMB, STRAIGHT JACK RECEPTACLE
SMA, JACK, RIGHT ANGLE RECEPTACLE
SMA, PLUG RECEPTACLE, RIGHT ANGLE
SMA, STRAIGHT JACK RECEPTACLE
SMA, STRAIGHT PLUG RECEPTACLE

2.4 Model Number

The radio model number is printed on the label on the end of the radio's enclosure. It provides key information about how the radio was configured when it left the factory. This number is subject to many variations depending on what options are installed and where (country) the product is used. Contact the factory if you have questions on the meaning of the code.

2.5 Spread Spectrum Radios—How Are They Different?

The main difference between a traditional (licensed) radio and the MDS TransNET transceiver is that this unit “hops” from channel to channel many times per second using a specific hop pattern applied to all radios in the network. A distinct hopping pattern is provided for each of the 65,000 available network addresses, thus minimizing the chance of interference with other spread spectrum systems. In the USA, Canada, and certain other countries, no license is required to install and operate this type of radio system, provided that RF power and antenna gain restrictions are observed.

2.6 Typical Applications

Multiple Address Systems (MAS)

This is the most common application of the transceiver. It consists of a central control station (master) and two or more associated remote units, as shown in [Figure 2](#). This type of network provides communications between a central host computer and remote terminal units (RTUs) or other data collection devices. The operation of the radio system is transparent to the computer equipment. This application provides a practical alternative to traditional (licensed) MAS radio systems.

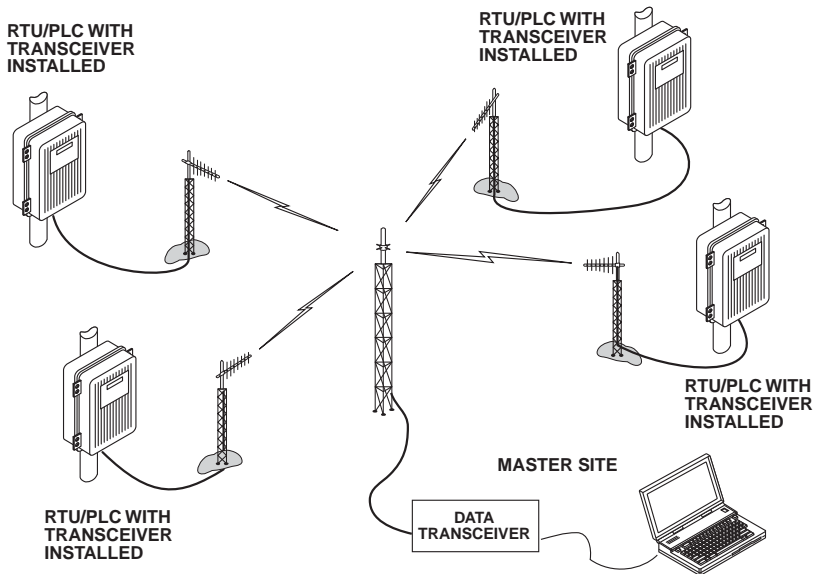

Figure 2. Typical MAS Network

Point-to-Point System

A point-to-point configuration (Figure 3) is a simple arrangement consisting of just two radios—a master and a remote. This provides a half-duplex communications link for the transfer of data between two locations.

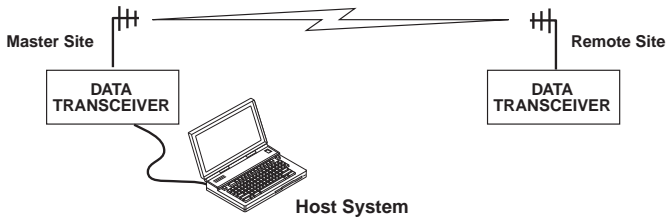

Figure 3. Typical Point-to-Point Link

Tail-End Link to an Existing Network

A tail-end link is often used to extend the range of a traditional (licensed) MAS system without adding another licensed radio. This might be required if an outlying site is blocked from the MAS master station by a natural or man-made obstruction. In this arrangement, a spread spectrum transceiver links the outlying remote site into the rest of the system by sending data from that site to an associated transceiver installed at one of the licensed remote sites—usually the one closest to the outlying facility. (See Figure 4).

As the data from the outlying site is received at the associated transceiver, it is transferred to the co-located licensed radio (via a data crossover cable) and is transmitted to the MAS master station over the licensed channel. Additional details for tail-end links are given in Section 6.2 (Page 19).

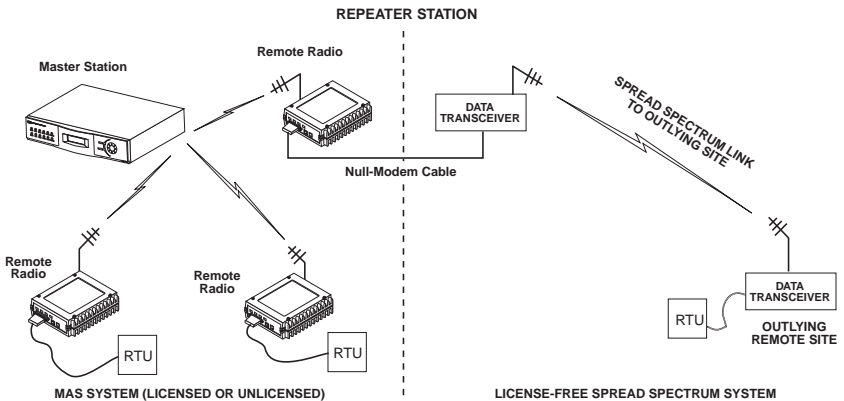

Figure 4. Typical Tail-End Link Arrangement

Store-and-Forward Repeater

Similar to a Tail-End Link, Store-and-Forward (SAF) offers a way to physically extend the range of a network, but in a simplified and economical manner. SAF operates by storing up the data received from one site, and then retransmitting it a short time later. [Figure 5](#) shows a typical SAF repeater arrangement.

SAF operates by dividing a network into a vertical hierarchy of two or more sub-networks. Extension radios (designated as **MODE X**) serve as single-radio repeaters that link adjacent sub-networks, and move data from one sub-network to the next. Additional information on SAF mode is provided in [“SAF Operation with Extension Radios” on Page 20](#).

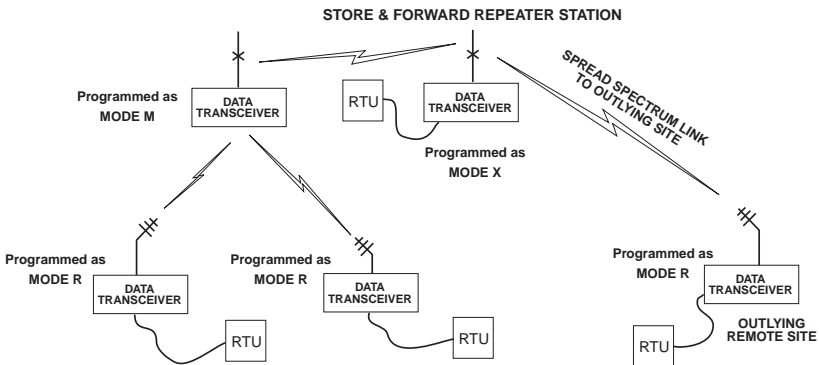

Figure 5. Store-and-Forward Repeater Network

2.7 Transceiver Accessories

One or more of the accessories listed in [Table 3](#) may be used with the OEM transceiver. Contact your factory representative for availability and ordering details.

Table 3. OEM Transceiver Accessories

Accessory	Description	Part No.
AC Power Adapter	Small power supply module designed for continuous service. UL approved. Input: 120/220 Vac Output: 12 Vdc @ 500 mA (20 Watts)	01-3682A02
2-Pin DC Power Plug	Mates with power connector on the transceiver. Screw terminals are provided for wires.	73-1194A39
Fuse (Internal)	Fuse, 2A SMF Slo-Blo	29-1784A03
Omnidirectional Antennas	Rugged antennas suited for use at Master stations.	Various; Consult factory
900 MHz Yagi Antennas	Rugged directional antennas suited for use at Remote stations.	Various; Consult factory

Table 3. OEM Transceiver Accessories (Continued)

2400 MHz Antennas	Rugged directional antennas suited for use at Remote stations.	Various; Consult factory
900 MHz Bandpass Filter	Antenna system filter to aid in eliminating interference from paging system transmissions.	20-2822A02
TNC-to-N Adapter Cable (3 ft./1 meter)	Coaxial cable used to connect the radio's TNC antenna connector to a Type-N style commonly used on large-diameter coaxial cables.	97-1677A159
TNC-to-N Adapter Cable (6 ft./1.8 meter)	Coaxial cable used to connect the radio's TNC antenna connector to a Type-N style commonly used on large-diameter coaxial cables.	97-1677A160
TNC-to-N RF Adaptor Plug	Adapts radio's antenna connector to Type-N style commonly used on large-diameter coaxial cables.	97-1677A161
RS/EIA-232 Cable	Shielded data cable fitted with DB-9 male and DB-9 female, 6 ft./1.8 meter.	97-1971A03
RJ-11 to DB-9 Adapter Cable	For connecting a PC terminal to the transceiver via the radio's DIAG(nostics) connector. Used for programming and diagnostics.	03-3246A01
Evaluation Development Kit	Kit containing two OEM Transceiver modules, whip antennas, two Evaluation Boards, support software on CD, cables, power supplies and other accessories needed to operate the transceiver in a benchtop setting.	32-4051A01

3.0 BENCHTOP SETUP & EVALUATION

As an integrator, your first task is to verify that the OEM module will function as intended with the host equipment. This section describes how to test the unit for operation with host devices such as RTUs, PLCs and similar gear. It covers the steps for making interface connections, powering up the transceiver, and setting configuration parameters using a connected PC.

Evaluation of the module is best performed in a controlled environment, such as a shop or lab facility where you can readily test various hardware and programming configurations and observe the effects of these changes before final installation.

Once you are satisfied that the transceiver module operates properly on the bench, you can plan the installation of the module inside the host device and be assured of proper operation in the field.

NOTE: Before using the Evaluation PCB, please review the detailed information on the Evaluation PCB and its functions, see [“EVALUATION DEVELOPMENT KIT \(P/N 03-4053A01\)” on Page 73.](#)

3.1 Initial Power-Up & Configuration

When all of the cable connections described in [“Cable Connections for Benchtop Testing” on Page 75](#) have been made, the transceiver is ready for initial power-up. Operation begins as soon as power is applied, and there are no manual adjustments or settings required.

To place the transceiver into operation:

1. Ensure that all cable connections are properly wired and secure. Verify that no metallic objects are touching the underside of the evaluation board which might cause a short-circuit.
2. Apply DC power. The GP indicator (CR6) on the transceiver board should light continuously.
3. Using a connected PC terminal, configure the unit with the proper mode (master or remote), network address and data parameters. See [Configuration Settings](#) below for programming details.
4. Observe the transceiver’s LED indicators for proper operation. [Table 4 on Page 11](#) shows the functions and normal indications of the LEDs.
5. Verify that the transceiver is transmitting and receiving data (TXD, RXD) in response to the master station and/or connected terminal device.

Configuration Settings

This section explains how to set the essential operating parameters of the transceiver. For more information on connecting a PC terminal, refer to [“User Commands” on Page 34](#).

6. The three essential settings for the Transceiver are as follows:

Mode—Master, Remote, or Extension

Network Address—a unique number from 1 to 65000

Data Interface Parameters—bps, data bits, parity, stop bits

- a. Set the Mode using the **MODE M** (Master), **MODE R** (Remote), or **MODE X** (Extension) command. (Note that there can be only *one* Master radio in a system.)

If *any* **MODE X** radios are used in the network, SAF must be turned on at the Master station. The **MODE X** radio must be programmed with an Extended Address (**XADDR**). Units that need to hear the **MODE X** radio must be programmed with an appropriate **XPRI** and/or **XMAP** value. (See [“SAF Operation with Extension Radios” on Page 20](#) for more information.)

- b. Set a unique Network Address (1–65000) using **ADDR** command. Each radio in the system *must* have the same network address. *Tip: Use the last four digits of the Master’s serial number to help avoid conflicts with other users.*

- c. Set the baud rate/data interface parameters. Default setting is 9600 bps, 8 data bits, no parity, 1 stop bit. If changes are required, use the **BAUD xxxxx abc** command where **xxxxx** denotes the data speed (300–115200 bps) and **abc** denotes the communication parameters as follows:

- a** = Data bits (7 or 8)
- b** = Parity (N for None, O for Odd, E for Even)
- c** = Stop bits (1 or 2)

NOTE: 7N1, 8E2 and 8O2 are invalid interface parameters for this transceiver.

Configuring Multiple Remote Units

In most installations, the Remote radios will be programmed with virtually the same set of parameters. This process can be streamlined by testing key pieces of equipment—such as the Master, Remote, and any Extensions—on a benchtop setup prior to installation. This allows you to test various configurations in a controlled environment.

Once the evaluation network is working satisfactorily, you can save the configuration of each unit in a data file on your PC through the use of *TransNET Configuration Software*. You can then open the Remote configuration file and install it in the next Remote radio. The software prevents you from overwriting unit or other mode-specific parameters.

3.2 Tail-End Links

A tail-end link is established by connecting an MDS TransNET Series radio “back-to-back” with another identical radio such as a licensed MDS x710B Series transceiver. This can be used to link an outlying Remote site into the rest of an MAS network. (Figure 4 on Page 5 shows a diagram of a typical tail-end link system.) The wiring connections between the two radios in a tail-end link system should be made as shown in Figure 11.

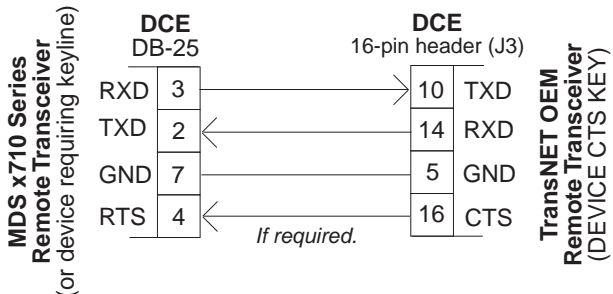

Figure 6. Data Interface Cable Wiring for Tail-End Links

Any device on the left that requires a keyline, as in this illustration, will require the bottom line (CTS to RTS) and the TransNET OEM on the right will need its **DEVICE** type set to **CTS KEY**. See **DEVICE**, on [Page 44](#) for details.

3.3 Configuring a Network for Extensions

The installation and configuration of an Extension transceiver is straightforward with only a few unique parameters that need to be considered and set at each unit.

In every network there can be only one Master station. It will serve as the sole gateway to the outside world. The tables in “[Configuration Parameters for Store & Forward Services](#)” on [Page 24](#) detail the parameters that need to be set on each type of radio in the network. For a detailed description of this network design, see “[SAF Operation with Extension Radios](#)” on [Page 20](#).

3.4 LED Indicators

The LED indicators are located to the right of the transceiver’s shield cover (near J3) and show important information about status of the module. The functions of LEDs are explained in [Table 4](#) below.

NOTE: For the LEDs to function, they must be enabled using the **LEDS ON** command.

Within 16 seconds of power-up, the following indications will be seen if the unit has been properly configured and is communicating with another transceiver:

- GP (General Purpose) lamp lit continuously
- DCD lamp lit continuously (if unit is synchronized with another station)

- Remote radio(s) transmitting data (TXD) and receiving data (RXD) with another station.

Table 4. LED Indicator Descriptions

	LED Name	Description
	RXD (CR3) Receive Data	Serial receive data activity. Payload data from connected device.
RXD	TXD (CR4) Transmit Data	Serial transmit data activity. Payload data to connected device.
TXD	DCD (CR5) Data Carrier Detect	Continuous—Radio is receiving/sending synchronization frames On within 10 seconds of power-up under normal conditions
DCD	GP (CR6) General Purpose	<ul style="list-style-type: none"> • Continuous— Power is applied to the radio; no problems detected • Flashing (5 times-per-second)— Fault indication. See “TROUBLESHOOTING” on Page 57 • Off— Radio is unpowered or in Sleep mode
GP		

4.0 TRANSCEIVER MOUNTING

This section provides information for mounting the OEM transceiver in a host device. The module need only be protected from direct exposure to the weather. No additional RF shielding is required.

[Figure 7](#) shows the dimensions of the transceiver board and its mounting holes. If possible, choose a mounting location that provides an unobstructed view of the radio’s LED status indicators when viewing the board from outside the host device.

Mount the transceiver module to a stable surface using the four mounting holes at the corners of the PC board. Standoff spacers should be used to maintain adequate clearance between the bottom of the circuit board and the mounting surface. (Fasteners/anchors are not normally supplied.)

Figure 8 on Page 12 provides details for the locations of the RF and interface connectors.

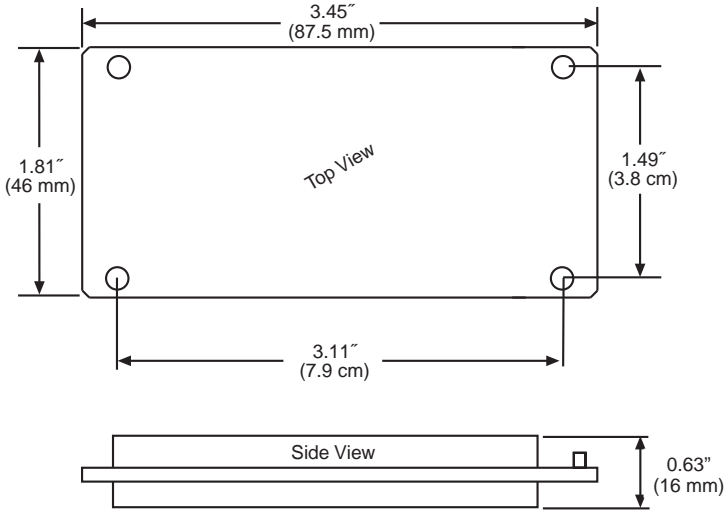

Figure 7. Transceiver Mounting Dimensions

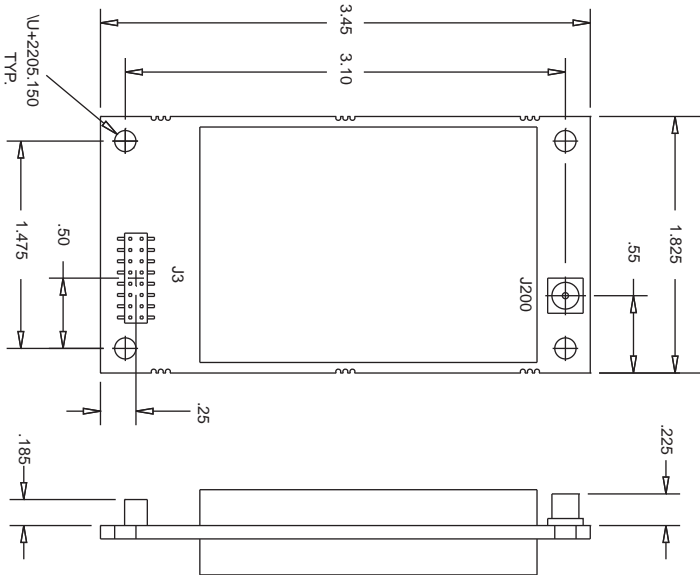

Figure 8. RF and Interface Connectors Locations
RF connector shown in J200 location

4.1 Antenna & Feedline Selection

Antennas

The equipment can be used with a number of antennas. The exact style used depends on the physical size and layout of a system. Contact your factory representative for specific recommendations on antenna types and hardware sources.

In general, an omnidirectional antenna ([Figure 9](#)) is used at the Master station site in an MAS system. This provides equal coverage to all of the Remote sites.

NOTE: Antenna polarization is important. If the wrong polarization is used, a signal reduction of 20 dB or more will result. Most systems using a gain-type omnidirectional antenna at the Master station employ vertical polarization of the signal; therefore, the Remote antenna(s) must also be vertically polarized (elements oriented perpendicular to the horizon).

When required, horizontally polarized omnidirectional antennas are also available. Contact your factory representative for details.

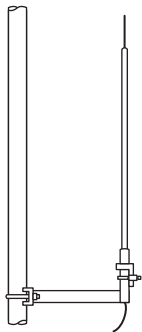

Figure 9.
Omnidirectional Antenna
(mounted to mast)

At Remote sites and point-to-point systems, a directional Yagi antenna ([Figure 10](#)), is generally recommended to minimize interference to and from other users. Antennas are available from many sources including GE MDS.

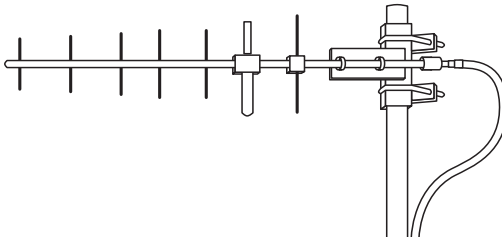

Figure 10. Typical Yagi Antenna
mounted to a mast

Feedlines

The choice of feedline used with the antenna should be carefully considered. Poor-quality coaxial cables should be avoided, as they will degrade system performance for both transmission and reception. The cable should be kept as short as possible to minimize signal loss.

For cable runs of less than 20 feet (6 meters), or for short range transmission, an inexpensive type such as Type RG-8A/U may be acceptable. Otherwise, we recommend using a low-loss cable type suited for 900 MHz, such as Times Microwave LMR 400[®] or Andrew Heliax[®].

Table 5 lists several types of feedlines and indicates the signal losses (in dB) that result when using various lengths of each cable at 900 MHz and Table 6 for 2.4 GHz. The choice of cable will depend on the required length, cost considerations, and the amount of signal loss that can be tolerated.

Table 5. Length vs. loss in coaxial cables at 900 MHz

Cable Type	10 Feet (3.05 Meters)	50 Feet (15.24 Meters)	100 Feet (30.48 Meters)	300 Feet (91.44 Meters)
LMR 400	0.39 dB	1.95 dB	3.9 dB	Unacceptable Loss
1/2 inch HELIAX	0.23 dB	1.15 dB	2.29 dB	6.87 dB
7/8 inch HELIAX	0.13 dB	0.64 dB	1.28 dB	3.84 dB
1-1/4 inch HELIAX	0.10 dB	0.48 dB	0.95 dB	2.85 dB
1-5/8 inch HELIAX	0.08 dB	0.40 dB	0.80 dB	2.4 dB

Table 6. Length vs. loss in coaxial cables at 2400 MHz

Cable Type	10 Feet (3.05 Meters)	50 Feet (15.24 Meters)	100 Feet (30.48 Meters)	300 Feet (91.44 Meters)
LMR-400	0.70 dB	3.50 dB	6.61 dB	Unacceptable Loss
1/2 inch HELIAX	0.35 dB	1.73 dB	3.46 dB	17.3 dB
7/8 inch HELIAX	0.20 dB	0.99 dB	1.97 dB	9.85 dB
1-1/4 inch HELIAX	0.15 dB	0.73 dB	1.45 dB	7.50 dB

Antenna System Ground

Precautions should be taken to assure the antenna and its support structure are bonded to a good earth ground system to minimize the impact of voltages created by lightning and atmospheric charges.

CAUTION: Safety grounding systems are beyond the scope of this manual. Below you will find some elementary advice. These are generalities; every location and installation is unique and requires a unique safety grounding system design. Please consider consulting a radio system engineer or other professional for advice on ground system design. A well-designed ground system will minimize risk of electrical shock to personnel and the chances of equipment damage.

Antenna Selection—Choose an antenna that offers a “DC ground” or direct low-impedance ground connection for all metallic components. This will allow static charges on the antenna system to be safely dissipated to ground. It will also provide a low-impedance path to an earth/safety ground in the event of a lightning discharge.

Support Earth/Safety Ground—The structure that supports your antenna system should have a large-gauge ground wire that goes as directly as possible to a safety/earth ground system. If a tower is used, it should have its own ground system. Do not use the building’s AC-power supply ground as a safety ground for lightning protection.

Chassis Ground—Connect a safety/earth ground to the ground post provided on the electronic/electrical equipment. If a ground terminal is present, bond the chassis to the safety ground at a point that is as close as possible to the antenna system and primary power entry points on the chassis.

5.0 PERFORMANCE OPTIMIZATION

After the basic operation of the radio has been checked, you may wish to optimize its performance using some of the suggestions given here. The effectiveness of these techniques will vary with the design of your system and the format of the data being sent.

Complete instructions for using the commands referenced in this manual are provided in “**RADIO PROGRAMMING**” on Page 33.

Antenna Aiming

For optimal performance, directional antennas must be accurately aimed in the direction of desired transmission. The easiest way to do this is to point the antenna in the approximate direction, then use the Remote radio's **RSSI** command (Received Signal Strength Indicator) to further refine the heading for maximum received signal strength.

In an MAS system, RSSI readings are only meaningful when initiated from a Remote station. This is because the Master station typically receives signals from several Remote sites, and the RSSI would be continually changing as the Master receives from each Remote in turn. Adjust the antenna for the highest (most positive) value to ensure the greatest communication reliability.

Antenna SWR Check

It is necessary to briefly key the transmitter for this check by placing the radio in the **SETUP** mode ([Page 52](#)) and using the **KEY** command. (To unkey the radio, enter **DKEY**; to disable the **SETUP** mode and return the radio to normal operation, enter **Q** or **QUIT**.)

The SWR of the antenna system should be checked before the radio is put into regular service. For accurate readings, a wattmeter suited for 1000 MHz is required. One unit meeting this criteria is the Bird Model 43 directional wattmeter with a 5J element installed.

The reflected power should be less than 10% of the forward power ($\approx 2:1$ SWR). Higher readings usually indicate problems with the antenna, feedline or coaxial connectors.

Data Buffer Setting—MODBUS™ Protocol

The default setting for the data buffer is **OFF**. This allows the radio to operate with the lowest possible latency and improves channel efficiency. MODBUS™ protocol and its derivatives are the only protocols that should require the buffer to be turned on. See “**BUFF [ON, OFF]**” on [Page 42](#) for details.

NOTE: The **BUFF ON** setting may introduce high latency. For time-critical MODBUS™ applications, buffering can also be achieved by setting the **RXD** delay value. This lowers the latency, but may not be as robust as **BUFF ON**. The desired **RXD** value can be approximated by the following:

$$\text{RXD value} = (9600/\text{BAUD value}) * \text{HOPTIME value} * \text{REPEAT value} * \text{SAF multiplier.}$$

(The SAF multiplier is 1 for SAF OFF and 2 for SAF ON.)

As an example, with 9600bps, HOPTIME 7, REPEAT 3, SAF ON, the **RXD** delay should typically be set to 42. $([9600/9600] * 7 * 3 * 2 = 42)$

Hoptime Setting

The default hop-time setting is **7** (7 ms). An alternate setting of **28** milliseconds may be used to increase throughput, but at the cost of increased latency. More information on the **HOPTIME** command can be found on [Page 45](#).

TotalFlow™ Protocol at 9600 with Sleep Mode

For reliable operation with TotalFlow meters, use the default settings for 9600 with the following alterations:

HOPTIME 28—Allows large data packets

FEC OFF—Improves store-and-forward performance for a large continuous data stream

BUFF ON—Ensures “ungapped” 4-second polls if unit is in sleep mode

Operation at 115200 bps

Burst throughput at 115200 bps is supported at all settings. The radio will always buffer at least 500 characters. Sustained throughput at 115200 bps is only possible when the data path is nearly error-free and the operating settings have been properly selected. For sustained operation at 115200 bps, use the following settings: **SAF OFF**, **FEC OFF**, **REPEAT 0**, **RETRY 0**, **HOPTIME 28**.

Baud Rate Setting

The default baud rate setting is 19200 bps to accommodate most systems. If your system will use a different data rate, you should change the radio’s data interface speed using the **BAUD xxxxx abc** command (Page 41). It should be set to the highest speed that can be sent by the data equipment in the system. (The transceiver supports 300 to 115200 bps.)

Radio Interference Checks

The radio operates in eight frequency zones. If interference is found in one or more of these zones, the **SKIP** command (Page 53) can be used to omit them from the hop pattern. You should also review *7.0 DEALING WITH INTERFERENCE*, when dealing with interference problems, when interference problems are encountered.

5.1 How Much Output Power Can be Used?

Refer to the Antenna Gain/Power Data charts at the front of this manual for approved antenna types and maximum RF power settings for the transceiver. You must ensure compliance with all applicable rules for the country of operation before placing the transmitter on the air.

6.0 OPERATING PRINCIPLES & SPECIAL CONFIGURATIONS

IMPORTANT: The following discussion of setup and commands is generic to TransNET radios and networks. Since it is not known if your network will be made up of only TransNET OEM transceivers, or a mixture of OEM and standard packaged versions, references to the DATA and INTERFACE ports can be used interchangeably. The DIAGNOSTIC port is only available on the standard transceiver and on the Evaluation PCB. For the TransNET OEM, this connection can be made through the Evaluation PCB, or a user-provided connection.

6.1 Synchronizing Network Units

The Master controls the synchronization for a given network for all modes. Setting the Master to **SAF ON** broadcasts a command from the Master to all radio units in the associated network either directly or through an Extension radio. This command puts *all radios in the entire system* in a special time-division duplexing mode that alternates between two timeslots. One time slot is for data communications upstream and the second for downstream communications.

The Extensions are single radios which serve as bridges between adjacent sub-network levels. Extensions will undertake a “Remote personality” in one timeslot, and a “Master personality” in the alternate timeslot and provide communications with associated Remotes downstream. Extensions behave like two radios with their data ports tied together, first synchronizing with their upstream Master during their Remote personality period, and then providing synchronization signals to dependent Remotes downstream during their Master personality period.

All Remotes synchronize to a corresponding Master. This can be the “real Master” (the **MODE M** unit), or it can be a repeater “Extension” that derives synchronization from the “real Master.”

Payload polls/packets broadcast from the network Master will be repeated to all levels of the network, either directly to Remotes, or through network repeaters—the Extension station. The targeted Remote responds to the poll following the same path back to the Master.

Synchronization Messages

Remotes acquire synchronization and configuration information via **SYNC** messages. They can synchronize to the Master (the **MODE M** unit) or to any valid Extension (a **MODE X** unit).

The Master will always transmit **SYNC** messages. An Extension will only start sending **SYNC** messages after synchronization is achieved with its Master.

The ability to synchronize to a given radio is further qualified by the sender’s Extended Address (**XADDR**) and by the receiver’s Synchronization Qualifiers (**XMAP**, **XPRI**, and **XRSSI**).

When a primary is specified (**XPRI** is 0...31), a radio will always attempt to find the primary first. If 30 seconds elapses and the primary is not found, then the radio attempts to synchronize with any non-primary radio in the **XMAP** list.

Once every 30 minutes, if a primary is defined, the radio will check its synchronization source. If the radio is synchronized to a unit other than the primary, then the current **RSSI** value is compared to the **XRSSI** value. If **RSSI** is less than **XRSSI** (or if **XRSSI** is **NONE**) the radio will force a loss-of-synchronization, and hunt for the primary again (as described in the previous paragraph).

By default, Extensions (and the Master) begin with **XADDR 0**. Synchronization qualifiers are set to **XMAP 0**, **XPRI 0**, and **XRSSI NONE**, respectively. This default configuration allows any radio to hear the Master. When an Extension is added, *the extended address of the Extension radio must be set to a unique value*. All Remotes that need to hear that extension can specify this either by designating the extension as the primary (**XPRI**), or by including it in their list of valid synchronization sources (**XMAP**).

6.2 Establishing a Tail-End Link

A tail-end link can be used to bring an outlying remote site into the rest of an MAS network. [Figure 4 on Page 5](#) shows a diagram of this type of system.

A tail-end link is established by connecting an OEM transceiver “back-to-back” with another unit such as a licensed MDS x710 Series transceiver. The wiring connections between the two radios must be made as shown in [Figure 11](#). In addition, the **DEVICE CTS KEY** command must be asserted at the OEM radio.

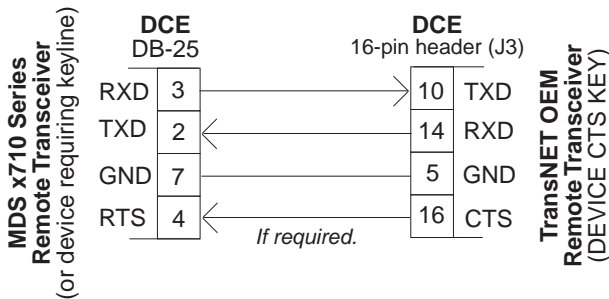

Figure 11. Data Crossover Cable for Tail-End Links

6.3 SAF Operation with Extension Radios

The Store-and-Forward (SAF) capability operates by dividing a network into a vertical hierarchy of two or more sub-networks. (See [Figure 5 on Page 6.](#)) Adjacent sub-networks are connected via Extension radios operating in “**MODE X**” which move data from one sub-network to the next one.

The Store-and-Forward implementation adheres to the general polling principles used in most multiple-address systems (MAS). Polls originate from the Master station, broadcast to *all* radios within the network, and travel hierarchically downward. All Remotes will hear the same message, but only one Remote will respond. Messages within a hierarchy only travel in one direction at a time.

Using SAF will cut the overall data throughput in half, however, multiple networks can be inter-connected with no additional loss in network throughput.

Simple Extended SAF Network

The following example depicts a two-level network utilizing a single Master (M) and an Extension (X) radio. See [Figure 12.](#)

In this network, messages directed to Remotes in the “K” sub-network, will be relayed through Extension radio $X_{j,k}$ to the K-Remotes. Any response from a Remote in sub-network “K” will pass back through Extension radio $X_{j,k}$ to the Master M_j . Radios in sub-network “J” operate on the same set of frequencies and sub-network “K” but with a different radio-frequency hopping pattern.

In SAF operation, the Extension radios are set to **MODE X** ([Details Page 48](#)) and operate with a “dual personality”—50% of the time it serves as a Remote station and 50% of the time as a Master for sub-network Remotes.

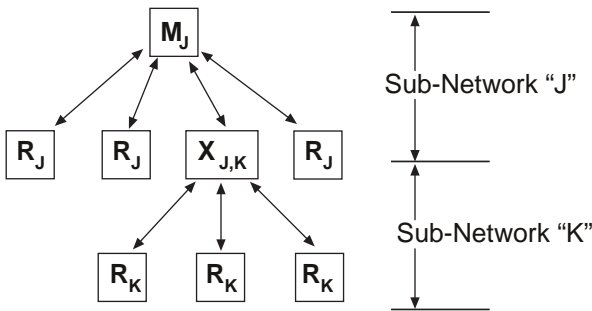

Figure 12. Simple Extended SAF Network
Networks: J and K

Extended SAF Network

Below is an example of a multilevel network utilizing two repeaters— $X_{J,K}$ and $X_{K,L}$. The example demonstrates the extensibility of the network. In this case, messages directed to Remotes in the sub-network L will be relayed through Extension radios $X_{J,K}$ and $X_{K,L}$. Like the previous example, the Extension radios split their operating time equally between their Master and Remote personalities. This multi-layered network can be extended indefinitely without degradation in throughput, beyond that initially incurred by placing the network in the SAF mode.

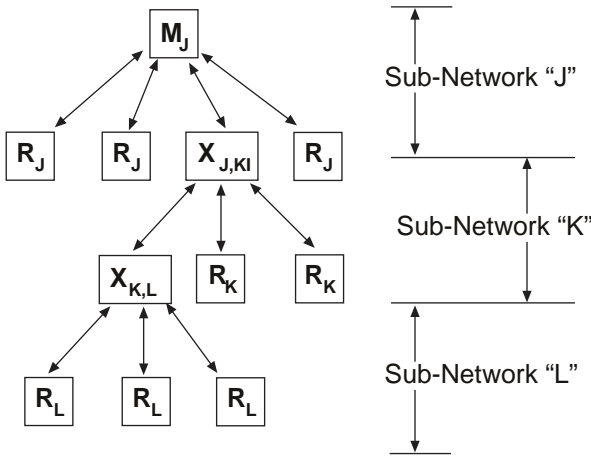

Figure 13. Extended SAF Network

Networks: J, K, L

Retransmission and ARQ Operation

Functionally, the sub-network side of an Extension behaves like a corresponding connection between a Master and a Remote.

When an Extension is using its "Master personality" it sends acknowledgments and performs unconditional retransmissions based on its **REPEAT** count.

When an Extension is using its "Remote personality," acknowledgments are processed and retransmissions occur as needed, up to the number of times specified by the **RETRY** count value.

If data arrives from a new source prior to completion of retransmissions, it is considered to be a violation of the polling model protocol. The new data takes precedence over the old data, and the old data is lost. In such a situation, new data is likely to be corrupted as it will have some old data mixed in with it.

SAF Configuration Example

The following is an outline for the configuration of a simple store-and-forward link.

1. **Mode X and M Radios**—Can have direct reports (Mode R radios) outside of the chain.
2. **Data (Payload)**—Travels from Master to Remote, and back from Remote to Master.
3. **Mode X and R Radios**—Extension links can be protected by mapping one or more fall-back paths in case of a failure. Add secondary extension addresses (XADDR) into the XMAP table. (See “XMAP [00000000-FFFFFFFF]” on Page 55.)

For example, as shown in Figure 14, Remote “D” could use Remote “C” as its extension primary, and Remote “B” (X ADDR = 1) as an alternative in case of a failure of Remote “C” (X ADDR = 2). This arrangement assumes a serviceable path between Remotes “D” and “B” and requires Remote “D” to be programmed with XMAP = 2 to correspond with the XADDR address of Remote “B.”

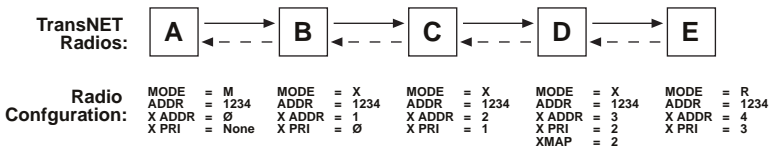

Figure 14. SAF Configuration Example

This configuration is easily arranged through the use of the **Extension Map** in the *MDS TransNET Configuration Software’s “Store-and-Forward Settings.”*

6.4 Using AT Commands

A TransNET network may be configured to support protocols employing Hayes-Compatible modem commands through the radio’s AT Mode. In this mode, TransNET units can provide a communications replacement for dial-up modems where the RTUs and the protocol do not contain addressability, and the establishment of a direct-communications link is the only way to determine if the RTU has data ready to be sent.

This requirement is common in many older SCADA systems which were developed for direct connections where wire lines were the only communications link available at the time. Most of these older system implemented support for the AT commands needed in the host software, so TransNET units can be used without software modifications.

In this mode, the Master's **DATA** port is parsed for a subset of AT commands. (See *Supported Commands* below). When an **ATDTxxxxx** data sequence is detected, and **xxxxx** is a unit address of a radio in the network, the TransNET Master will establish a virtual link to that unit. It will remain in that state until either another **ATDTxxxxx** or **ATH** (hang-up/disconnect) is detected. (Note: Unaddressed Remotes in the network will not respond to user data. Data will only be exchanged between the equipment connected to the addressed Remote unit and the network or device connected to the Master's **DATA** port.

To use this mode, the command **AT ON** must be selected at the Master Radio. The acknowledgment to an ATDT command is simulated by the Master; there is no true verification that the far-end connection is valid.

Please consider the following additional information before using the AT commands:

- Radio commands and AT commands are independent with unique syntax and functional objectives.
- **ATDT** is not a radio command; it is part of the payload data input and follows the syntax for Hayes-compatible landline modems.
- TransNET commands are entered through the RJ11 DIAGNOSTIC port on Master and Remote radios. **AT ON** and **UNIT** are examples of TransNET commands.
- AT commands are only entered through the Master's DATA port, and only when the TransNET command **AT ON** has been previously issued. The radio supports a *subset* of the Hayes-compatible modem AT set. Each command is *entered without spaces*, and always begins with **AT**, and *ends with a carriage return key press*.

Supported AT Commands

Supported modem commands on the payload port are:

AT <attention>

Replies with **OK** (Code 0).

ATDT[xxxxx] <dial>

The command **xxxxx** represents 5-digit unit address with a leading zero (0) if applicable. This command replies with **CONNECT** (Code 1). Once connected, all characters are passed through until a +++ is seen.

ATH <hang up> or +++

This command replies with **OK** (Code 0) and deletes any virtual connection to the currently addressed Remote station.

ATV[x] <change verbosity>

x = 0, means use numeric messages

x = 1, means use text messages (Default)

Replies with **OK** (Code 0)

AT <command errors>

Replies with **ERROR** (Code 4)

Characters with <no AT command>

Modem will echo characters in the data stream but will be ignored until a second “AT” is seen at which time the modem closes the virtual connection.

Operating Notes when AT Commands are ON

- Radios will not poll with the embedded RTU simulator unless a connection is established.
- Network-wide diagnostics are unaffected by the dialed unit connection status.
- The use of the TransNET **OT** command (Output Trigger) can be of benefit in some configurations. See “**OT [ON, OFF]**” on Page 49 for configuration details.

6.5 Configuration Parameters for Store & Forward Services

The installation and configuration of a radio network with an Extension using SAF is straightforward with only a few unique parameters that need to be considered and set at each unit.

In every network there can be only one Master station. It will serve as the sole gateway to the outside world. The following three tables detail the parameters that will need to be set on each type of radio in the network.

- Network Master Radio—[Table 7 on Page 24](#)
- Extension Radio(s)—[Table 8 on Page 25](#)
- Remote Radio(s)—[Table 9 on Page 26](#)

Table 7. Configuration Parameters for SAF Services
Network Master Radio

Parameter	Command	Description
Operating Mode	MODE M <i>Details Page 48</i>	Sets the radio to serve as a Master.
Network Address	ADDR <i>Details Page 40</i>	A number between 1 and 65,000 that will serve as a common network address. All radios in the network use the same number.

Table 7. Configuration Parameters for SAF Services
Network Master Radio (Continued)

Parameter	Command	Description
Extended Address	XADDR <i>Details Page 55</i>	A number between 0 and 31 that will serve as a common address for radios that synchronize directly to this Master. Typically, the Master is set to zero (0).
Store-and-Forward Mode	SAF ON <i>Details Page 52</i>	Enables store-and-forward capability in the network.

Table 8. Configuration Parameters for SAF Services
Extension Radio(s)

Parameter	Command	Description
Operating Mode	MODE X <i>Details Page 48</i>	Sets the radio to serve as an Extension.
Network Address	ADDR <i>Details Page 40</i>	A number between 1 and 65,000 that will serve as a common network address. All radios in the network use the same number.
Extended Address	XADDR <i>Details Page 55</i>	A number between 0 and 31 that will serve as a common address for radios that synchronize directly to this Extension radio serving as Master for associated sub-network units. Zero (0) is recommended for the Master station.
Primary Extended Address	XPRI <i>Details Page 56</i>	XADDR number of the primary or preferred radio with which this radio will synchronize.
Extension Map	XMAP <i>Details Page 56</i>	Lists all XADDR values with which this radio can synchronize, excluding the XPRI address.
Extension Received Signal Strength Indicator	XRSSI <i>Details Page 56</i>	The minimum RSSI level required to preserve synchronization with a non-primary radio. (Ineffective when XPRI is NONE)

Table 9. Configuration Parameters for SAF Services
Remote Radio(s)

Parameter	Command	Description
Operating Mode	MODE R <i>Details Page 48</i>	Sets the radio to serve as a Remote station.
Network Address	ADDR <i>Details Page 40</i>	A number between 1 and 65,000 that will serve as a common network address or name. Same number for all units in the same network.
Primary Extended Address	XPRI <i>Details Page 56</i>	XADDR number of the primary or preferred radio with which this radio will synchronize.
Extension Map	XMAP <i>Details Page 56</i>	Lists all XADDR values with which this radio can synchronize, excluding the XPRI address.
Extension Received Signal Strength Indicator	XRSSI <i>Details Page 56</i>	The minimum RSSI level required to preserve synchronization with a non-primary radio. (Ineffective when XPRI is NONE)

6.6 Using the Radio's Sleep Mode *(Remote Units Only)*

In some installations, such as at solar-powered sites, it may be necessary to keep a Remote transceiver's power consumption to an absolute minimum. This can be accomplished using the radio's Sleep Mode feature. Power consumption (current) in sleep mode will be less at higher input voltages and more at lower input voltages. Power in the Sleep Mode at 13.8 Vdc is approximately 3 mA.

Sleep Mode can be enabled under RTU control by asserting a ground (or EIA/RS-232 low) on Pin 4 of the radio's DATA connector. All normal functions are suspended until it is awakened by removing the low from Pin 4.

When Pin 4 is opened (or an EIA/RS-232 high is asserted), the radio will be ready to receive data within 75 milliseconds. The radio can be awakened more often if desired, by your RTU.

NOTE: The **SLEEP** function must be set to **ON**; without this, a ground on Pin 4 will be ignored.

It is important to note that power consumption will increase somewhat as communication from the Master station degrades. This is because the radio will spend a greater period of time “awake” looking for synchronization messages from the Master radio.

In order for the radio to be controlled by Pin 4, the unit’s Sleep Mode must be enabled through the **SLEEP [ON, OFF]** command. See “**SLEEP [ON, OFF]**” on [Page 54](#) for more information.

NOTE: If **INTRUSIVE** polling is used in InSite NMS software, it is necessary to select **SLEEP MODE INHIBIT ON** from the **Polling Options** menu, on the **Network Wide Diagnostic Polling** screen.

Sleep Mode Example

The following example describes Sleep Mode implementation in a typical system. Using this information, you should be able to configure a system that meets your own particular needs.

Suppose you need communications to each Remote site only once per hour. Program the RTU to raise an EIA/RS-232 line once each hour (DTR for example) and wait for a poll and response before lowering it again. Connect this line to Pin 4 of the radio’s DATA connector. This will allow each RTU to be polled once per hour, with a dramatic reduction in power consumption.

6.7 Low-Power Mode (LPM)—Master Enabled

The Low-Power Mode (LPM) puts Remote radios into a configuration similar to Sleep, but with some important distinctions. The most important difference is that the radio will automatically go to sleep in this mode, regardless of the condition of Pin 4 of the DATA interface connector.

This feature trades increased latency to gain power savings. The low-power mode (LPM) automatically saves power at a Remote by instructing the Remote to shutdown for long periods of time between SYNC messages. Master transmissions are automatically blocked while the Remotes are asleep. Note, both Masters and Remotes are adaptive and will suppress a normal sleep interval until after the end of a current data transmission or reception.

Setup Commands

These are the command options and their applications:

- **LPM 1** at the Master enables low-power mode network-wide; all Remotes pick it up and start saving power by automatically sleeping.
LPM 1 can work in conjunction with the AT dialing feature. The dialed unit will be forced awake; all others will sleep.
- **LPM 0** at the Master is used to disable low-power mode (LPM) (Default setting following an **INIT** or firmware upgrade.)

For **LPMHOLD 0** with **REPEAT 0** setting, a Remote with no data to send will consume about 1/4 of its normal power consumption. Note that the **SLEEP** command must be enabled for the LPM to function.

Reading RSSI & Other Parameters with LPM Enabled

It may be desired to perform tests and review operational settings of a Remote radio which has been programmed to operate in the low-power mode. Follow the abbreviated procedure below to interact with the radio through a local computer.

- Disconnect the Remote’s antenna to force it to lose sync with the Master
- Power-down the radio
- Connect a computer running TransNET configuration software to the Remote’s DIAG(nostic) port.
- Power-up the radio
- Reconnect the antenna
- Measure the RSSI or review and change any parameters you desire

Power Consumption Influence by HOPTIME and SAF Settings

Table 10 shows representative current consumption and data delay values for various settings of TransNET radios setup for Low Power Mode, LPM (See “LPM [1, 0]” on Page 47). It assumes the primary power voltage is 13.8 Vdc and the polling rate is minimized to yield best-case power consumption (current) values.

The more each RTU is polled and asked to transmit, the more current will be consumed. Therefore, these values are the lowest that can be expected. Power consumption (current) is inversely related to data delay as shown in the table. When a radio is sleeping (LPM) mode, it is also waiting longer to deliver the payload data.

Table 10. Power Consumption *versus* Hoptime and SAF Settings

HOPTIME	SAF	Current (ma)	Data Delay
7	OFF	16	350 ms
7	ON	10	780 ms
28	OFF	7	1620 ms
28	ON	4	3360 ms

Note, the Store-and-Forward setting has a significant effect on power consumption, as it effectively doubles the HOPTIME to support LPM services. For the most power-efficient operation, turn on SAF even if you are not using repeaters.

6.8 Low-Power Mode versus Remote's Sleep Mode

The Low-Power Mode (LPM) puts Remote radios into an operational configuration similar to Sleep, but there are some important differences. Below is a comparison of the two modes.

Table 11. Power-Conservation Modes Comparison

	Sleep Mode	Low-Power Mode
Features	<ul style="list-style-type: none"> • Manual control by connected equipment • Selective application of Sleep control • User determines length and frequency of sleep periods 	<ul style="list-style-type: none"> • Automatic radio-controlled timing • Automatic sleep during absence of directed traffic • Network-wide implementation through Master station
Benefits	<ul style="list-style-type: none"> • Low latency • Low standby power, $\bar{\delta}$ 3 mA at 13.8 Vdc • Greatest potential for power savings 	<ul style="list-style-type: none"> • Less complicated implementation • Simple configuration

6.9 Mobile Operation Support

Introduction

Reliable mobile operation of Remotes is practical in areas covered by multiple Master Stations within the same network—Master stations with the same Network Address (**ADDR**). To make this type of service practical, the Remote must have several reliable Master stations with which to communicate.

A “reliable” Master is defined as one, which consistently matches, or exceeds, the Remote’s standard for Minimum RSSI (**MRSSI**).

Initially, the Remote will favor Masters with signal strengths 10 dB greater than the MRSSI threshold. This will allow for some signal degradation of the new Master as the Remote travels.

When the average signal level from the currently-associated Master falls below the user-defined **MRSSI** level, the Remote will become out-of-sync and seek an alternate Master with a reliable signal.

Operational Influences—Hoptime and SAF

The synchronization period is influenced by two parameters' values—**HOPTIME** and **SAF** (Store-and-Forward). [Table 12](#) shows several configurations and the associated synchronization period value.

Table 12. Synchronization Period versus Hoptime and SAF Settings

Sync Period	Hoptime Value	SAF
441 ms	7	OFF
1.8 sec	28	OFF
3.5 sec	28	ON

6.10 MIRRORED BITS™ Protocol Support

TransNET radios are compatible with Schweitzer's Mirrored Bits MB8 protocol, provided complementary firmware (06-4045A01) is installed in *all* network radios. A detailed application guide (AG2003-07) is available from Schweitzer Engineering Labs Web site, www.SELinc.com/aglist.htm, or from GE MDS' Web site at www.GEmds.com.

6.11 Seamless Mode Emulation

The **RXD** command *assumes* the payload message will be ready for transmission after the delay period has expired. If there is a chance the payload data may be delayed, it is recommended to use the **BUFF(er)** command to make sure the entire message is received before delivery is started. The **BUFF** command provides a highly-reliable seamless operating mode, but can be slow to start, especially if it waits for the reception of long messages before passing on the message.

6.12 Full-Duplex Emulation

If your system design needs to support PTP or Point-to-Multipoint applications and your communications must appear to be full-duplex to the connected devices, set the Master to **CSADDR xxxxx** (where **xxxxx** is the Network Address (**ADDR**)). This will place the system in a time-division duplex mode (TDD). The radio system will appear to be full-duplex to the connected devices, but actually operates half-duplex over the radio link. Data is buffered by the transmitting side until it is its turn to transmit. Throughput will be approximately 1/2 of the DATA interface rate.

6.13 Co-Located and Close-Proximity Masters

If your requirements call for multiple TransNET networks at the same location, you need to ensure that interference between the systems is minimized to prevent overload that will diminish the performance of the radios. Traditionally, vertical separation of the antennas of co-located radios was required

in order to reduce the interference to the point where overload of one network by the other will not occur. The **CSADDR** command will provide relief from this antenna separation requirement by operating the networks in a TDD mode and ensuring that one Master cannot transmit while the other (or multiple others) are trying to receive a signal from a distant radio.

Master Station Configuration

On all Masters for which you wish to synchronize transmissions, establish one Master as the “Clock-Sync Master by setting its **CSADDR** value to its own Network Address (**ADDR xxxxx**). Then, set all other dependent Masters **CSADDR** values to the Network Address (**ADDR**) of the Clock-Sync Master. Make sure that you use a different Network Address (**ADDR**) for each Master. This value will be used to identify all units associated with this Master’s network.

Note that all Masters must be set to the same **CSADDR** setting, but only one where the **CSADDR** matches its own **ADDR**; this is the Clock-Sync Master.

CSADDR = ADDR—Unit serving as a Clock-Sync Master

CSADDR ≠ ADDR—Unit serves as a Dependent Master (Clock Slave)

CSADDR = NONE—Co-located Master feature disabled (default)

HOPTIME, **FEC** and **SAF** values are provided by the Clock-Sync Master to all dependent units.

NOTE: If a Dependent Master station is unable to find the Clock-Sync Master station, it will not be able to operate properly and the associated network will be out-of-service.

Antenna System for Co-Located Master Stations

Using this TDD (Clock-Sync) mode will prevent any two Masters from transmitting at the same time and greatly reduce the antenna separation requirements to near zero. Under this arrangement, the antennas of co-located Masters may be placed a few feet (less than a meter) apart horizontally, or just above or below vertically with no ill effects. There are two common antenna system arrangements:

Sharing a Common Antenna System

It is possible to share an antenna between multiple Masters using standard power dividers, as long as the extra loss associated with these devices is taken into account in your RF “budgeting” process. Masters in this configuration must be operating with Clock-Sync (**CSADDR**) enabled.

For example, the two Master stations shown in [Figure 15](#) are connected to a common antenna system. They use a power-divider that will result in a signal loss of 3 dB, or one-half power level, on both transmit and receive signals.

The power divider, such as a Mini-Circuits ZAPD-1 or similar product, must be capable of handling 1 Watt and have >25 dB isolation between TX ports.

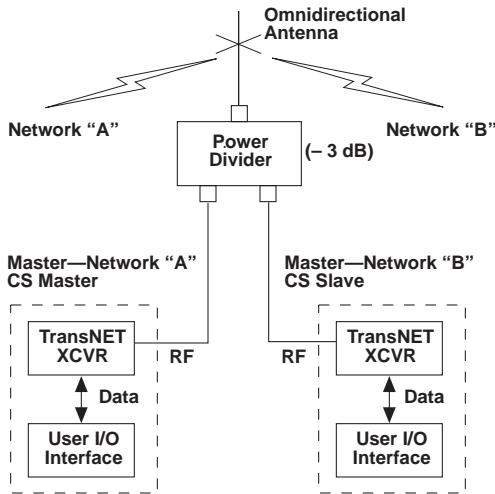

Figure 15. Co-Located Masters Sharing an Antenna

7.0 DEALING WITH INTERFERENCE

The radio shares the frequency spectrum with other services and other Part 15 (unlicensed) devices in the USA, Canada, and certain other countries. As such, near 100% error free communications may not be achieved in a given location, and some level of interference should be expected. However, the radio's flexible design and hopping techniques should allow adequate performance as long as care is taken in choosing station location, configuration of radio parameters and software/protocol techniques.

In general, keep the following points in mind when setting up your communications network:

1. Systems installed in rural areas are least likely to encounter interference; those in suburban and urban environments are more likely to be affected by other devices operating in the license-free frequency band and by adjacent licensed services.
2. If possible, use a directional antenna at Remote sites. Although these antennas may be more costly than omnidirectional types, they confine the transmission and reception pattern to a comparatively narrow lobe, which minimizes interference to (and from) stations located outside the pattern.
3. If interference is suspected from a nearby licensed system (such as a paging transmitter), it may be helpful to use horizontal polarization of all antennas in the network. Because most other services use vertical polarization in these bands, an additional 20 dB of attenuation to interference can be achieved by using horizontal polarization.

- Multiple transceiver systems can co-exist in proximity to each other with only very minor interference as long as they are each assigned a unique network address. Each network address has a different hop pattern.

Additional RF isolation can be achieved by using separate directional antennas with as much vertical or horizontal separation as is practical. Vertical separation of antennas is more effective per foot/meter than horizontal.

- If constant interference is present in a particular frequency zone, it may be necessary to “lock out” that zone from the radio’s hopping pattern. The radio includes built-in tools to help users remove blocked frequency zones. Refer to the discussion of the **SKIP** command (Page 53) for more information. In the USA, a maximum of four zones may be skipped, per FCC rules. Check the regulatory requirements for your region.
- Interference can also come from out-of-band RF sources such as paging systems. Installation of a bandpass filter in the antenna system may bring relief. (Contact the GE MDS Technical Services Department for recommendations and sources of suitable filters.)
- Proper use of the **RETRY** and **REPEAT** commands may be helpful in areas with heavy interference.

The **RETRY** command sets the maximum number of times (0 to 10) that a radio will re-transmit upstream data over the air. Values greater than 0 successively improve the chances of a message getting through when interference is a problem.

The **REPEAT** command sets a fixed number of unconditional retransmissions for downstream data.

- The RF power output of all radios in a system should be set for the lowest level necessary for reliable communications. This lessens the chance of causing unnecessary interference to nearby systems.

8.0 RADIO PROGRAMMING

There are no manual adjustments on the radio. Programming and control is performed through a PC connected to the radio’s DIAG connector.

NOTE: Access to the transceiver and network-wide diagnostics is dependent on the user-designed and provided interface to the TransNET OEM module. The following discussion and others in this manual assume a suitable user-provided interface is available.

8.1 Radio Programming Methods

Terminal Interface

A PC may be used by operating it in a basic terminal mode (for example, a HyperTerminal session) and entering the radio commands listed in the tables found in “**RADIO PROGRAMMING**” on Page 33. The PC must be connected to the radio’s DIAG port.

Once connected, communication (baud rate) is established through the command interface. To access the command interface, press the **[ESC]** key, followed by one or more **[ENTER]** keystrokes (delivered at about half-second intervals), until the “>” prompt is displayed.

NOTE: The DIAG port (RJ-11 connector) uses 8 data bits, 1 stop bit, and no parity. It can automatically configure itself to function at 1200, 2400, 4800, 9600, 19200, 38400, 57600, and 115200 bps. [Default: **BAUD** = 9600]

If the **DLINK** setting is **ON**, the DIAG port will start out in Diagnostic Link mode. This is a special protocol used to support Network-Wide Diagnostics. The process described in the paragraph above causes the radio to exit the diagnostic link mode and enter the command mode. If there is no input in command mode for 5 minutes, the DIAG port will revert back to diagnostic link mode.

PC-Based Configuration Tool

The MS Windows™-based *MDS TransNET Configuration Software* (P/N 06-4059A01) is designed for use with a PC connected to the radio’s diagnostics port.

The *TransNET Configuration Software* provides access to all of the radio’s capabilities with the benefit of context-sensitive help. The program is shipped as part of the TransNET support CD included with every order (Part No. 03-2708A02)

8.2 User Commands

A series of tables begin on the next page that provide reference charts of various user commands for the transceiver. See “[Detailed Command Descriptions](#)” on [Page 40](#) for more details.

Entering Commands

The proper procedure for entering commands is to type the command, followed by an **[ENTER]** keystroke. For programming commands, the command is followed by **[SPACE]**, the appropriate information or values, and then **[ENTER]**.

Table 13. Network Configuration—Master Station

COMMAND	DESCRIPTION
AT [ON, OFF] <i>Details Page 41</i>	Enables Master station to emulate a modem and respond to AT commands
BUFF [ON, OFF] <i>Details Page 42</i>	ON = Seamless data OFF = Fast byte throughput.
FEC [ON, OFF] <i>Details Page 45</i>	Sets/disables FEC (Forward Error Correction) setting.
HOPTIME [7, 28] <i>Details Page 45</i>	Displays hop-time or sets it to 7 or 28 ms.
LPM [1, 0] <i>Details Page 47</i>	Used at Master to set all associated stations in an energy-conservation mode. 1 = Low-power mode enabled network-wide 0 = Disable low-power mode (Default)
REPEAT <i>Details Page 50</i>	Sets/displays the fixed downstream re-send count.
RETRY [0–10] <i>Details Page 50</i>	Sets/displays the maximum upstream re-send count for ARQ (Automatic Repeat Request) operation
SAF [ON, OFF] <i>Details, page 52</i>	Enables/disables the store-and-forward function for the network controlled by this Master unit.
SKIP [NONE, 1...8] <i>Details, page 53</i>	Skip one or more frequency zones

Table 14. Network-Wide Diagnostics

Command	Description
DLINK [xxxxx/ON/OFF] <i>Details, page 44</i>	Controls operation of diagnostic link function.
DTYPE [NODE/ROOT] <i>Details, page 45</i>	Set radio's operational characteristics for network-wide diagnostics

Table 15. Operational Configuration—Set/Program

Command	Description
ADDR [1–65000] <i>Details, page 40</i>	Program network address
AMASK [0000 0000–FFFF FFFF] <i>Details, page 41</i>	Alarm response Default: FFFF FFFF
ASENSE [HI/LO] <i>Details, page 41</i>	Sense of the alarm output on Pin 6 of the INTER-FACE connector in the EIA-232 mode. Default: Alarm present = HI
BAND [A, B, C] <i>Details Page 42</i>	Selects one of three operating bands. (2.4 GHz Model Only)
BAUD [xxxxx abc] <i>Details, page 41</i>	Data communication parameters
CODE [NONE, 1...255] <i>Details, page 42</i>	Select the security/encryption setting in the radio
CSADDR [1–65000, NONE] <i>Details, page 43</i>	Used on a single Master/Remote network to support TDD-style simulated full-duplex.
CTS [0–255] <i>Details, page 43</i>	CTS delay in milliseconds (A value of 0 returns CTS immediately)
CTSHOLD [0–60000] <i>Details, page 43</i>	“Hold time” that CTS is present following last character from DATA port.
DEVICE [DCE, CTS KEY] <i>Details, page 44</i>	Device behavior: DCE (normal) or CTS Key
MODE [M, R, X] <i>Details, page 48</i>	Operating mode: M = Master, R = Remote, X = Extension
MRSSI [NONE, –40...–90] <i>Details, page 48</i>	Minimum RSSI level required to preserve synchronization with a Master radio for Remotes in mobile service.
OT [ON, OFF] <i>Details, page 49</i>	Enables a 1-second delay on delivery of RXD serial data.
OWN [xxxxx] <i>Details, page 49</i>	Owner’s name, or alternate message (30 characters maximum)
PORT [RS232, RS485] <i>Details, page 49</i>	Data port (DATA connector) interface signaling mode: RS232 or RS485
PWR [20–30] <i>Details, page 49</i>	Power output in dBm (Figure 35 on Page 84)
RXD [0–255] <i>Details, page 51</i>	Set RXD delay time for virtual seamless mode with low latency

Table 15. Operational Configuration—Set/Program (Continued)

Command	Description
RXTOT [NONE, 0–1440] <i>Details, page 51</i>	Maximum duration (in minutes) before time-out alarm. Default is OFF.
RTU [ON, OFF, 0-80] <i>Details, page 51</i>	Enable or Disable unit’s built-in RTU simulator. Default is OFF. Set RTU address between zero and 80.
SLEEP [ON, OFF] <i>Details, page 54</i>	Enable or Disable the radio’s energy-conservation Sleep mode function.
UNIT [10000–65000] <i>Details, page 55</i>	Unit address used for network-wide diagnostics. (Unique within associated network.)
XADDR [0–31] <i>Details, page 55</i>	This unit’s Extended address Typically, the Master is set to zero (0).
XMAP [00000000-FFFFFFFF] <i>Details, page 55</i>	Included Extended units in MODE X. (Extensions and Remotes only)
XPRI [0–31] <i>Details, page 56</i>	Address of the primary Extended radio unit (Extension).
XRSSI [NONE, –40...–120] <i>Details, page 56</i>	Minimum RSSI level required to preserve synchronization with a non-primary radio. (Only meaningful when XPRI is not NONE)
ZONE CLEAR <i>Details, page 56</i>	Reset zone data statistics

Table 16. Operating Status—Display Only

Command	Description
ADDR <i>Details Page 40</i>	Network address
AMASK <i>Details Page 41</i>	Alarm mask (response)
ASENSE <i>Details Page 41</i>	Current sense of the alarm output.
BAUD <i>Details Page 41</i>	Data communication parameters. Example: BAUD 9600 8N1
BUFF <i>Details Page 42</i>	Data buffering mode: ON = seamless data, OFF = fast byte throughput
CODE <i>Details Page 42</i>	Security/encryption operational status. “NONE” (Inactive), or “ACTIVE”

Table 16. Operating Status—Display Only (*Continued*)

Command	Description
CTS <i>Details Page 43</i>	CTS delay in milliseconds (0–255 ms)
CTSHOLD <i>Details Page 43</i>	“Hold time” that CTS is present following last character from DATA port.
DEVICE <i>Details Page 44</i>	Device behavior Alternatives: DCE and CTS KEY
HOPTIME <i>Details Page 45</i>	Hop-time value in milliseconds (ms).
LPMHOLD <i>Details Page 48</i>	Time (0-1000 ms) provided to give an RTU time to respond before the radio goes to sleep.
MODE <i>Details Page 48</i>	Current operating mode: M = Master R = Remote X = Extension (Repeater)
MRSSI <i>Details Page 48</i>	Minimum RSSI level required to preserve synchronization with a Master radio for Remotes in mobile service.
OWM <i>Details Page 49</i>	Owner’s message or site name
OT <i>Details Page 49</i>	Status (ON/OFF) of the 1-second delay on delivery of RXD serial data.
OWN <i>Details Page 49</i>	Owner’s name or system name
PORT <i>Details Page 49</i>	Current data port (DATA connector) interface signaling mode: RS232 or RS485
PWR <i>Details Page 49</i>	Forward power-output setting in dBm
REPEAT <i>Details Page 50</i>	The fixed downstream re-send count.
RETRY <i>Details Page 50</i>	The maximum upstream re-send count for ARQ (Automatic Repeat Request) operation.
RSSI <i>Details Page 50</i>	Received signal strength indicator (in dBm). Unavailable at Master unless SETUP is enabled.
RTU <i>Details Page 51</i>	RTU simulator’s operational status (ON/OFF)

Table 16. Operating Status—Display Only (*Continued*)

Command	Description
RXTOT <i>Details Page 51</i>	The amount of time (in seconds) to wait before issuing a time-out alarm.
SAF <i>Details Page 52</i>	Store-and-forward mode status in this unit. (ON/OFF)
SER <i>Details Page 52</i>	Serial number of radio
SHOW CON <i>Details Page 52</i>	Display virtual modem connection status
SHOW PWR <i>Details Page 53</i>	RF output power. Measured RF power in dBm.
SHOW SYNC <i>Details Page 53</i>	Information on synchronization source
SKIP <i>Details Page 53</i>	Frequency zones that are skipped
SLEEP <i>Details Page 54</i>	Radio's Sleep Mode setting. (At Remotes Only)
SREV <i>Details Page 54</i>	Transceiver firmware revision level
STAT <i>Details Page 54</i>	Current alarm status
TEMP <i>Details Page 55</i>	Transceiver's internal temperature (°C)
UNIT <i>Details Page 55</i>	Programmed unit address for network-wide diagnostics
XADDR <i>Details Page 55</i>	This unit's Extended address
XPRI <i>Details Page 56</i>	Address of the primary Extended radio unit (Extension).
XMAP <i>Details Page 55</i>	Included Extended units in MODE X. (Extensions and Remotes only).
XRSSI <i>Details Page 56</i>	Minimum RSSI level required to preserve synchronization with a non-primary radio. (Only meaningful when XPRI is not NONE)

Table 17. Diagnostic and Test Functions

Command	Description
KEY <i>Details Page 47</i>	Enables the transmitter test. (Must be in Setup mode. Details on page 52.)
DKEY <i>Details Page 44</i>	Turns off the transmitter test. (Must be in Setup mode. Details on page 52.)
TX [xxxx] <i>Details Page 55</i>	Set/display transmit test frequency. (Must be in Setup mode. Details on page 52.)
RX [xxxx] <i>Details Page 51</i>	Set/display receive test frequency. (Must be in Setup mode. Details on page 52.)
SETUP <i>Details Page 52</i>	Enables Setup mode. Times out after 10 minutes. Press “Q” to quit.
ZONE DATA <i>Details Page 56</i>	Zone data statistics
ZONE CLEAR <i>Details Page 56</i>	Clears the Zone Data log

8.3 Detailed Command Descriptions

The essential commands for most applications are Network Address (**ADDR**), Mode (**MODE**), and Baud Rate (**BAUD**). However, proper use of the additional commands allows you to tailor the transceiver for a specific use, or to conduct basic diagnostics on the radio. This section gives more detailed information for the commands listed above in [Section 8.2](#).

Most of the commands below can be used in two ways. First, you can type only the command name (for example, **ADDR**) to view the currently programmed data. Second, you can set or change the existing data by typing the command, followed by a space, and then the desired entry (for example, **ADDR 1234**). In the descriptions which follow, allowable programming variables, if any, are shown in brackets [] following the command name.

ADDR [1–65000]

Network Address

This command sets or displays the radio’s network address. The network address can range from 1 to 65000.

A network address must be programmed at the time of installation and must be common across each radio in a given network. Radios are typically shipped with the network address unprogrammed, causing the address to display as **NONE**. If the address is not set (or is set to a wrong value) it leaves the system in an invalid state, preventing operation and generating an alarm.

NOTE: It is recommended that the last four digits of the Master radio’s serial number be used for the network address. This helps avoid conflicts with other users.

AMASK [0000 0000–FFFF FFFF]

Alarm Mask

This command sets the alarm bits that cause the alarm output signal to be triggered. The PWR LED still flashes for all alarms, but the alarm output signal is only activated for those alarms having the corresponding mask bit set. The hex value for the mask aligns directly with the hex value for the **ALARM** command. The default is **FFFF FFFF**. Through proper use of the **AMASK** command, it is possible to tailor the alarm response of the radio. Contact the factory for more information on configuring the alarm mask.

AT [ON, OFF]

Hayes-Compatible AT Command Support

AT-style modem commands, also known as “Hayes-Compatible Commands”, can be processed through the payload port. By setting **AT ON** at the Master (**MODE M**), individual Remotes can be accessed by using **ATDT** [Unit Address]. In this mode, RTUs designed only for dial-up access can be accessed through the Master station. For more details, see See “Using AT Commands” on Page 22 and “OT [ON, OFF]” on Page 49.

ASENSE [HI/LO]

Alarm Output Sense

This command is used to set the sense of the alarm output at Pin 3 of the OEM module’s INTERFACE connector, J3, and Pin 6 of the Evaluation’ PCB’s DATA connector. The default is **HI** which means an alarm is present when an RS-232 high is on Pin 6.

BAUD [xxxxx abc]

Data Interface Port Baud Rate

This command sets or displays the communication attributes for the normal payload communications through the DATA port. The command has no effect on the RJ-11 DIAG(NOSTICS) port.

The first parameter (**xxxxx**) is baud rate. Baud rate is specified in bits-per-second and must be one of the following speeds: 300, 600, 1200, 1800, 2400, 4800, 9600, 19200, 38400, 57600, or 115200. At baud rates of 19200 bps or less, the radio supports unlimited continuous data transmission at any hop rate.

The second parameter of the **BAUD** command (**abc**) is a 3-character block indicating how the data is encoded. The following is a breakdown of each character’s meaning:

- a** = Data bits (7 or 8)
- b** = Parity (N for None, O for Odd, E for Even)
- c** = Stop bits (1 or 2)

The factory default setting is 9600 baud, 8 data bits, no parity, 1 stop bit (Example: **9600 8N1**).

NOTE: 7N1, 8O2, and 8E2 are invalid communication settings and are not supported by the transceiver.

BAND [A, B, C]

Select Sub-Band (Normally used for 2.4 GHz model)

This command sets or displays the receiving and transmit operating band for the radio.

A = 2.4016–2.4270 GHz
B = 2.4272–2.4526 GHz
C = 2.4528–2.478.2 GHz

NOTE: The same **BAND** setting must be common across each radio in a given network and it must be programmed at the time of installation.

BUFF [ON, OFF]

Data Buffer Mode

This command sets or displays the received data handling mode of the radio. The command parameter is either **ON** or **OFF**. (The default is **OFF**.) The setting of this parameter affects the timing of received data sent out the DATA connector. Data transmitted over the air is unaffected by the **BUFF** setting.

If data buffering is set to **OFF**, the radio will operate with the lowest possible average latency. Data bytes are sent out the DATA port as soon as an incoming RF data frame is processed. Average and typical latency will both be below 10 ms, but idle character gaps may be introduced into the outgoing data flow.

If data buffering is **ON**, the radio will operate in a seamless mode. That is, data bytes will be sent over the air as quickly as possible, but the receiver will buffer the data until the entire packet has been collected. The delay introduced by data buffering is variable and depends on message size and the number of retransmissions required, but the radio will not create any gaps in the output data stream. This mode of operation is required for protocols such as MODBUS™ that do not allow gaps in their data transmission.

Seamless mode (**BUFF ON**) is intended only for applications where the message size is 256 characters or less. Enforcement of this rule is left up to the user. If more than 256 characters are transmitted data delivery will not be seamless and data may be lost.

Changes to the **BUFF** setting may only be made at the Master radio, as the Master radio broadcasts the buffer setting for the entire network. At Remote radios, the buffer setting may be read when the radio is in synchronization with the Master, but it cannot be changed.

CODE [NONE, 1...255]

Security Code

The **CODE** command is used to select or display the security/encryption setting in the radio.

The default is **CODE NONE**. Setting **CODE** to a value other than **NONE** provides an extra level of security beyond that provided by the Network Address (**ADDR**). The disadvantage is increased complexity in managing the network.

The **CODE** command takes an argument of **1...255**, or **NONE**. Entering **CODE** without an argument will display either **NONE** or **ACTIVE**. **ACTIVE** means that security/encryption has been enabled, but the radio *will not* display the security argument.

When a **CODE** value is active, *all radios in the system must use the same code value*. If the code value is not properly programmed, a Remote radio will not synchronize with the Master.

CAUTION: Record the **CODE** value and store it in a safe place. If the code is later forgotten, and a unit is to be added to the system, all radios in the network must be set to **NONE** and then reprogrammed to a new value.

CSADDR [1–65000, NONE]

Clock-Synchronizing Master Address

Used to specify the network address of a “Clock-Sync” Master station to which this station will be synchronized. Also see “**ADDR [1–65000]**” on [Page 40](#) and “**Co-Located and Close-Proximity Masters**” on [Page 30](#) for further details.

CTS [0–255]

Clear-to-Send Delay

The **CTS** (clear-to-send) command sets or displays the timer value associated with the CTS line response. The command parameter ranges from 0 to 255 milliseconds.

For DCE operation, the timer specifies how long to wait after the RTS line goes high before asserting the CTS line. A timer value of zero means that the CTS line will be asserted immediately following the assertion of RTS.

For CTS Key operation (see the **DEVICE** command), the timer specifies how long to wait after asserting the CTS line before sending data out the DATA port. A timer value of zero means that data will be sent out the data port without imposing a key-up delay. (Other delays may be in effect from other radio operating parameters.)

CTSHOLD [0–60000]

Clear-to-Send Hold Time

Used in **DEVICE CTS KEY** mode, this command sets the amount of time in milliseconds that CTS remains present following transmission of the last character out the RXD pin of the DATA port. This “hold time” can be used to prevent squelch tail data corruption when communicating with other radios.

The **CTSHOLD** setting can range from 0 to 60000 (i.e., 60 seconds). The default value is 0, which means that CTS will drop immediately after the last character is transmitted. If the command is entered when the radio is in **DEVICE DCE** mode, the response **CTSHOLD N/A** will be displayed.

DEVICE [DCE, CTS KEY]

Radio-MODEM Behavior

The **DEVICE** command sets or displays the device behavior of the radio. The command parameter is either **DCE** or **CTS KEY**.

The default selection is **DCE**. In this mode, CTS will go high following RTS, subject to the CTS programmable delay time. Keying is stimulated by the input of characters at the data port. Hardware flow control is implemented by dropping the CTS line if data arrives faster than it can be transmitted.

If **CTS KEY** is selected, the radio is assumed to be controlling another radio, such as in a repeater or tail-end link system. The RTS line is ignored and the CTS line is used as a keyline control for the other radio. CTS is asserted immediately after the receipt of RF data, but data will not be sent out the DATA port until after the CTS programmable delay time has expired. (This gives the other radio time to key.)

Following transmission of the last byte of data, CTS will remain asserted for the duration specified by the **CTSHOLD** command. **CTSHOLD** should be set sufficiently high.

DLINK [xxxxx/ON/OFF]

InSite Diagnostics Link Support

DLINK ON enables use of *Diagnostic Link* mode and establishes it as the default protocol on the DIAG port. *Diagnostic Link* mode is a special protocol used to support Network-Wide Diagnostics. **DLINK** must be set to **ON** to support connection to *InSite* or to support chained diagnostics between radio networks even while the radio is in sleep mode. **DLINK OFF** disables this feature. The default setting is **ON**.

The following **DLINK** baud rates selections are supported:

- 1200
- 4800
- 9600
- 19200 (default)
- 38400
- 57600
- 115200

Example: **DLINK 4800** sets the DIAG port to operate at 4800 bps when diagnostics is closed. This setting will not affect the port's autobaud operation. Use only of **DLINK ON**, will enable the use 19200 or the most recently programmed value. The default is **DLINK 19200** and **DLINK ON**.

NOTE 1: The same baud rate must be entered into the InSite Equipment List's **BAUD** field.

NOTE 2: The **DLINK** rate must match the rate of any connected device to the diagnostic port. This may be either another MDS radio's diagnostic port, InSite computer, or another data link device that eventually connects to the InSite computer.

DKEY

Turn Off Radio Transmitter 's Test Signal

Disables the transmitter when it is keyed. See also **KEY** command.

DTYPE [NODE/ROOT]

Network Diagnostics Mode

The **DTYPE** command specifies the radio's operational characteristics for network-wide diagnostics. The transceiver uses the following types:

- **NODE**—The most common setting, and the default. This is the basic system radio device-type. Typically, the radio network is comprised of nodes and one root. Intrusive diagnostics can originate from any node. However, non-intrusive diagnostics can only be conducted from the root node.
- **ROOT**—Always one, and only one, per network (including units associated through Extension units.) The root is the focal point of network-wide diagnostics information. Intrusive diagnostics can originate from any radio, including the root. However, the root is the *only* radio through which non-intrusive diagnostics can be conducted.

FEC [ON, OFF]

Forward Error Correction

This command is used to view the FEC setting, or turn it on or off. The default setting is **FEC ON**. (It needs to be turned off when throughputs exceed 57,600 bps.) FEC is set at the Master and is automatically passed on to all Remotes in a network.

Setting FEC to **ON** improves sensitivity at the cost of reduced throughput. Typical SCADA/telemetry applications use low data rates and, as such, the FEC setting is normally transparent to them.

HOPTIME [7, 28]

Radio Transmitter Hop Timing

The **HOPTIME** command is used to set or display the hop-time setting. The command is a digit corresponding to the hop-time setting in milliseconds. The default **HOPTIME** setting is 7. A setting of 28 must be used when throughputs exceed 57,600 bps and is recommended when data transmission sizes exceed 256 bytes.

Changes to the **HOPTIME** setting may only be made at the Master radio. (This is because the Master radio establishes the hop-time setting for the entire network.) At Remote radios, the hop-time setting may be read when the radio is in synchronization with the Master, but it cannot be changed.

INIT

Initialize; Restore to Factory Defaults

The **INIT** command is used to reset the radio's operating parameters to the factory defaults listed in [Table 18 on Page 46](#). This may be helpful when trying to resolve configuration problems that resulted from the entry of one or more improper command settings. If you are unsure of which command setting caused the problem, this command allows you to get back to a known working state.

NOTE: Caution should be exercised when using the **INIT** command on radios in a system employing the Store-and-Forward feature. Settings relating to the use of Extension services will be lost and will need to be re-entered. Record the settings for **XADDR**, **XPRI** and **XMAP** before using the **INIT** command.

SPECIAL

NOTE: Installing firmware of Revision 3.0 or later into a radio with Revisions 1.x firmware will preserve the radio's compatibility with other radios running Revision 1.x firmware. If updating the radio's firmware is part of a system-wide upgrade, the last step should be to use the **INIT** command at the Master station. Use of the **INIT** command causes the changes shown in [Table 18](#) to be applied.

Table 18. INIT Command Generated Defaults

Parameter	Default Setting	Corresponding Command
<i>For ALL radios</i>		
Alarm Mask	FFFF FFFF	AMASK
Alarm Output Sense	RS-232 High (+5.0 Vdc)	ASENSE
Device Operation	DCE	DEVICE DCE
DATA Interface Port	<ul style="list-style-type: none"> • 9600 baud • 8 data bits • none (no parity) • 1 stop bit 	BAUD 9600 8N1
Data Port Setting	RS/EIA-232	PORT RS232
CTS Delay	0 (CTS is continuously asserted)	CTS 0
CTS Hold-Time	0	CTSHOLD 0
LED Operation	OFF	LED
Low-Power Mode Hold	0	LPMHOLD
RX Time-Out-Timer	None/Disable	RXTOT
RF Output Power	30 dBm (1 watt)	PWR 30
Transmitter Test Frequency	915.000 MHz or 2436.0 MHz (Model dependent)	TX xxx
Receiver Test Frequency	915.000 MHz 2436.0 MHz (Model-dependent)	RX xxx
Sleep Mode	OFF	SLEEP OFF
Primary Extension Radio Address	0 (Master)	XPRI 0
Synchronization Source Map	None	XMAP 0
Extended Address	0	XADDR 0
<i>For MASTER radios</i>		
AT Command Support	OFF	AT

Table 18. INIT Command Generated Defaults *(Continued)*

Parameter	Default Setting	Corresponding Command
Buffer Mode	OFF	BUFF OFF
Forward Error Correction	ON	FEC ON
Hop-Time	7 ms	HOPTIME 7
Low-Power Mode	0 (Off)	LPM
Skipped Frequencies	None (radio will hop across all frequencies)	SKIP NONE
Retry Count	10 (max. of 10 repeats for ARQ)	RETRY 10
Repeat Count	3 (downstream repeats)	REPEAT 3

HREV

Hardware Revision

Shows the hardware revision of the radio.

KEY

Turn On Radio Transmitter Test Signal

Enables the transmitter. (Radio must be in Setup mode.) See also **DKEY** command (**DKEY** *Details, page 44*).

LED [ON, OFF]

Enable/Disable PCB LEDs

LED ON enables/disables the PCB board mounted LEDs seen only with the transceiver's covers removed. **LED** is normally **OFF**, it may be useful to have them on for testing the radio with the covers removed. Note: the *external* LEDs will be dimmer if the **LED** function is left **ON**.

The **LED** command also affects the operation of the LEDs in the "Low-Power Mode" (**LPM**). When **LED** is **OFF**, the radio keeps the PWR and SYNC LEDs extinguished.

LPM [1, 0]

Low-Power Mode—Masters Only

This feature trades increased latency to gain power savings. Low-power mode (**LPM**) automatically saves power at a Remote by instructing the Remote to shutdown for large periods of time in between **SYNC** messages. Master transmissions are automatically blocked while the Remotes are asleep. Note, both Masters and Remotes are adaptive and will suppress a normal sleep interval if data transmission or reception is in progress.

- **LPM 1** at the Master enables low-power mode network-wide; all Remotes pick it up and start saving power by automatically sleeping.

LPM 1 can work in conjunction with the AT dialing feature. The dialed unit will be forced awake; all others will sleep.

- **LPM 0** at the Master to disable low-power mode (Default setting).

The **SLEEP** command must be enabled for LPM to function. Further, when you enable LPM, the LEDs on the Remote radio dim even though the LPM function is not properly enabled by turning on **SLEEP**. For more information, see “[Low-Power Mode \(LPM\)—Master Enabled](#)” on Page 27, and “[Low-Power Mode versus Remote’s Sleep Mode](#)” on Page 29.

LPMHOLD [0–1000]

Low-Power Mode Sleep Time

Used to give an RTU time (0-1000 ms) to respond before the radio goes to sleep. Value determines how long to suppress auto-sleep following reception of the last character sent out of the RXD serial data port.

NOTE: Any values entered will be rounded to the nearest multiple of 4 ms.

To verify the exact hold time, enter **LPMHOLD**, the response will give you the value currently being used.

MODE [M, R, X]

Radio Operating Mode

The **MODE** command sets or displays the operating mode of the radio. A Master radio is set by **MODE M**; a Remote set by **MODE R**, and an Extension is set by **MODE X**.

All units default to Remotes; other modes must be specifically programmed with the **MODE** command.

If **MODE X** is used, the **MODE X** radio should be programmed with an Extended Address (**XADDR**). Units that need to hear this **MODE X** radio must be programmed with an appropriate **XPRI** and/or **XMAP** value.

MRSSI [NONE, –40...–90]

Minimum RSSI for Mobile Operation

The **MRSSI** command sets or displays the minimum RSSI level (dBm) of a Master station’s signal to maintain synchronization. When the Master’s signal falls below this level, the Remote will attempt to resynchronize with the next Master it can hear within the same network—same Network Address (**ADDR**)—and, meets the **MRSSI** level. See “[Mobile Operation Support](#)” on Page 29 for additional information.

OT [ON, OFF]

Output Trigger

The “output trigger” feature sets up a 1-second default delay on delivery of RXD serial data, however, a receipt of RTS causes cancellation of timer followed by immediate data delivery.

Hierarchy Rules:

- if **OT = ON**, RTS always cancels data delay and outputs immediately

- if **OT** = ON, **DEVICE** = DCE, and **RXD** = 0, data delay is 1 second or until RTS
- if **DEVICE** = DCE, and **RXD** = N, data delay is N ms
- if **DEVICE** = CTS KEY, and **CTS** = N, data delay is N ms or until RTS
- if **DEVICE** = CTS KEY overrides **RXD**, **RXD** overrides **OT** default.

OWM [xxxxxx]

“Owner’s Message”

The **OWM** command sets or displays an optional owner’s message, such as the system name. The entry can contain up to 30 characters.

OWN [xxxxxx]

“Owner’s Name”

The **OWN** command sets or displays an optional owner’s name, such as the site name. The entry can contain up to 30 characters.

PORT [RS232, RS485]

Data Interface Signaling Standard

Select or identify the current data INTERFACE connector’s, J3, signaling mode: RS232 or RS485. This is the port through which the payload data will pass. Pin descriptions for EIA-232 and EIA-485 variations begin on [“Transceiver Module’s Interface Connector, J3, Detailed Pin Descriptions” on Page 66](#). This command will not function on transceivers with a TTL signalling interface.

PWR [20–30]

Radio Transmitter Power Level

This command displays or sets the desired RF power output of the radio. The **PWR** command parameter is specified in dBm and can be adjusted in 1 dBm steps. The default setting is 30 dBm (1 watt) for the 900 MHz model and 27 dBm (0.5 watt) for the 2400 MHz model. To read the actual (measured) power output of the radio, use the **SHOW PWR** command.

In the USA, maximum allowable power is governed by FCC limits on Effective Isotropic Radiated Power output (EIRP). The EIRP limit of +36 dBm on the 900 and 2400 MHz band, means that any user with a net antenna gain greater than 6 dBi on the 900 MHz band, or 9 dBi on the 2400 MHz band, must decrease the **PWR** setting accordingly. [“How Much Output Power Can be Used?” on Page 17](#) contains a detailed discussion of this topic.

REPEAT [0–10]

Downstream Repeat Transmission Count

The **REPEAT** command affects “downstream” data. The command causes a Master or Extension to always repeat transmissions for the specified number of times (range is 0 to 10; default selection is 3). Unlike the **RETRY** command, there is no acknowledgment that a message has been received.

Use the **REPEAT** command without a value to display the current setting.

RETRY [0–10]

Upstream Repeat Transmission Count

The **RETRY** command affects upstream data. The command selects, or displays, the maximum number of times (0 to 10) that a Remote radio will re-transmit data. The default setting is 10.

This command is associated with ARQ (Automatic Repeat Request) operation of the radio and is intended for use in areas with heavy radio interference.

When the **RETRY** command is issued without parameters, the maximum retransmission count is shown. A value of 0 represents no retries, while values of 1 or greater successively improve the chance of data delivery in spectrally harsh environments (at the expense of possibly increased latency). The **RETRY** value is only setable at the Master. It is readable by a synchronized Remote.

RSSI

Received Signal Strength Indicator

This command displays the radio’s Received Signal Strength Indication in dBm (decibels relative to 1 mW). The output can range from –40 dBm to –120 dBm. Command availability and results depend on the mode of operation (Master or Remote). The closer to 0 dBm, the stronger the signal, thus a reading of –70 dBm is stronger than –80 dBm.

For a Remote radio, under normal operation, RSSI is based on the average signal strength of the SYNC message received in each of the eight frequency zones. (RSSI is sampled each time a SYNC message is received.) When using the RSSI reading to align a directional antenna, it is important to make changes slowly so that the RSSI reading will provide meaningful results. It will take several seconds to indicate a change in signal level. The radio stays in RSSI mode until **ENTER** is pressed.

For a Master radio, under normal operation, entering the RSSI command causes the response **NOT AVAILABLE** to be returned. This is because a Master is normally receiving signals from several Remote stations and an RSSI reading would be continually changing. The only exception is when the **SETUP** command has been asserted. This disables hopping and allows reading a “raw” RSSI signal level in real time from a Master or Remote radio.

NOTE 1: RSSI readings will not accurately indicate signals stronger than –40 dBm.

NOTE 2: RSSI works for Dependent Masters. Command displays “NOT AVAILABLE” if the Dependent Master is not synchronized.

RTU [ON, OFF, 0-80]

Remote Terminal Unit Simulator

This command re-enables or disables the radio's internal RTU simulator, which runs with factory-proprietary polling programs (poll.exe and rsim.exe). The internal RTU simulator is available whenever a radio has diagnostics enabled. This command also sets the RTU address to which the radio will respond.

The internal RTU can be used for testing system payload data or pseudo bit error rate (BER) testing. It can be helpful in isolating a problem to either the external RTU or the radio. The default RTU setting is **OFF**.

RX [xxxx]

Radio Receive Test Frequency

This command sets or displays the test receive frequency used in place of hopping when the radio is in **SETUP** mode. The test receive frequency can be reprogrammed to any value between 902.200 MHz and 927.800 MHz, inclusive. The factory default setting is 915.000 MHz.

RXD [0-255]

RXD Delay

Used to set a delay, in milliseconds, of RXD data to emulate a seamless mode with much lower latency in applications where retries are not required. Use a delay of twice the value of the **HOPTIME** period (See [Page 45](#)).

RXTOT [NONE, 0-1440]

Receive Data Timeout-Timer

This command sets or displays the amount of time (in minutes) to wait for the next received data packet before issuing a receiver time-out alarm. The default setting is **NONE**.

SAF [ON, OFF]

Store-and-Forward Services Support

This command enables/disables the operation of the Store-and-Forward services. It can be set only at the network's Master station, but will effect all radios in the associated network. The default setting is **OFF**. See related commands: "**XADDR [0-31]**" on [Page 55](#), "**XPRI [0-31]**" on [Page 56](#), and "**XMAP [00000000-FFFFFFFF]**" on [Page 55](#).

SETUP

Setup Radio Test

This command sets up the transceiver for checking antenna SWR or transmitter power with external measuring equipment. Do not use this mode during normal operation.

When the **SETUP** command is entered, the prompt changes to **SETUP>**, and:

- Hopping is disabled.

- Synthesizer frequencies are reset to the test frequencies specified by the **TX** and **RX** commands described earlier.
- The radio can be keyed using the **KEY** command. **DKEY** is used to unkey the radio. (If the radio is left in a keyed state it is automatically unkeyed after 10 minutes.)
- The **RSSI** is sampled in a raw, continuous fashion regardless of whether the unit is a Master or a Remote.

Entering **Q** or **QUIT** returns the system to normal operation.

A timer keeps the Setup mode from accidentally leaving the system disabled. After 10 minutes the system behaves as if **Q** or **QUIT** had been entered, returning the unit to normal operation.

NOTE: TransNET uses a automatic level control in normal operation to keep transmit power constant over time. This facility is disabled in Setup mode. To test 1 Watt power output in Setup mode, the user must enter **PWR 30** followed by **KEY**. The power output will only be valid for the first couple of seconds.

SER

Radio Serial Number

Displays the serial number of the radio.

SHOW CON

Show Virtual Connection Status

Shows virtual connection status established by the latest ATDT command sequence. (Works only with **AT ON**. See “**AT [ON, OFF]**” on Page 41)

If no connection is established, it displays **NONE**.

If a connection is active, it will display:

<Master unit address> **TO** <Remote (“dialed”) unit address>.

SHOW PWR

Show Measured RF Transmit Power

The **SHOW PWR** command displays the actual (measured) RF power output in dBm. Unlike the **PWR** command, this command shows the actual level being measured, not the programmed RF power setting.

SHOW SYNC

Show Clock-Synchronization Master Network Address

When used at a Remote station, this command will display **Extended Address** and **Unit Address** of the Master or Extension radio to which the Remote is synchronized. The network depth at the Remote, defined as the number of downstream links from the Master, is displayed in parentheses.

SHOW SYNC works for Dependent Masters. A value of zero (0) means the station is a Master synchronized to a Clock-Sync Master. The **SHOW SYNC** command will display an asterisk (*) after depth value if the radio is operating with co-located Masters.

SKIP [NONE, 1...8]

Skip Radio Operating Zones

This command sets or displays which, if any, of the eight zones will be skipped from the radio's hopping sequence. Skipping zones is one way of dealing with constant interference on one or more frequencies in the radio's operating band. See [“DEALING WITH INTERFERENCE” on Page 32](#) for more information on dealing with interference.

Tables 19, 20, 21 and 22 show the frequency range covered by each zone. The command parameter is either the keyword **NONE** or an undelimited string of up to four digits where each digit 1...8 represents a corresponding zone to skip. (For zone parameter input, the digits can appear in any order and can be optionally separated by a blank space.) The **SKIP** command is display-only at Remote radios. (Remotes must be synchronized with the Master radio to display the skip status.)

In the USA, a maximum of *four* zones may be skipped for TransNET 900 and a maximum of *three* zones may skipped for TransNET 2400. Check the regulatory requirements for your region. The **SKIP** function may not be permitted in your country and the radio will not respond to the **SKIP** command.

Table 19. 900 MHz Frequency Skip Zones

ZONE 1	ZONE 2	ZONE 3	ZONE 4	ZONE 5	ZONE 6	ZONE 7	ZONE 8
902.2	905.4	908.6	911.8	915.0	918.2	921.4	924.6
to	to	to	to	to	to	to	to
905.2	908.4	911.6	914.8	918.0	921.2	924.4	927.6

Table 20. 2400 MHz, Band A, Frequency Skip Zones

ZONE 1	ZONE 2	ZONE 3	ZONE 4	ZONE 5	ZONE 6	ZONE 7	ZONE 8
2401.6	2404.8	2408.0	2411.2	2414.4	2417.6	2420.8	2424.0
to	to	to	to	to	to	to	to
2404.6	2407.8	2411.0	2414.2	2417.	2420.6	2423.8	2427.0

Table 21. 2400 MHz, Band B, Frequency Skip Zones

ZONE 1	ZONE 2	ZONE 3	ZONE 4	ZONE 5	ZONE 6	ZONE 7	ZONE 8
2427.2	2430.4	2433.6	2436.80	2440.0	2443.2	2446.4	2449.6
to	to	to	to	to	to	to	to
2430.2	2433.4	2436.6	2439.8	2443.0	2446.2	2449.4	2452.6

Table 22. 2400 MHz, Band C, Frequency Skip Zones

ZONE 1	ZONE 2	ZONE 3	ZONE 4	ZONE 5	ZONE 6	ZONE 7	ZONE 8
2452.8	2456.0	2459.2	2462.4	2465.6	2468.8	2472.0	2475.2
to	to	to	to	to	to	to	to
2455.8	2459.0	2462.2	2465.4	2468.6	2471.8	2475.0	2478.2

SLEEP [ON, OFF]

Transceiver Sleep—Remotes Only

This command is used to set or display the radio's Sleep Mode setting. The default setting is **SLEEP OFF**. When this setting is **ON** (enabled) the Low-Power, or RTU-forced Sleep Mode, can be used. This function cannot be turned on for a Master or Extension radio unless the unit is in the Low-Power Mode. See “Using the Radio's Sleep Mode (Remote Units Only)” on Page 26 and “Low-Power Mode versus Remote's Sleep Mode” on Page 29 for more information.

SREV

Firmware Revision Level

This command displays the version of the firmware currently loaded into the transceiver.

A display of **06-4040A01, 3.6.1** is an example of the firmware version identifier—part number followed by release/version number.

STAT

Alarm Status

This command is used to check the alarm status of the radio. If no alarms exist, the message **NO ALARMS PRESENT** is returned.

If an alarm does exist, a two-digit alarm code (00–31) is displayed and the event is identified as a “Major” or “Minor” alarm. A brief description of the event is also given.

If more than one alarm exists, the word **MORE** appears, and additional alarms may be viewed by pressing the **[ENTER]** key. Detailed descriptions of the alarm codes are provided in [Table 23 on Page 58](#).

TEMP

Radio's Internal Temperature

This command displays the internal temperature of the transceiver in degrees Celsius. (Note that the radio is specified to operate in an environment between –30° C and +60° C). This internal reading may be higher than the outside temperature by several degrees.

TX [xxxx]

Radio Transmit Test Frequency

This command sets or displays the test transmit frequency used in place of hopping whenever the radio is in Setup mode. The test transmit frequency for the 900 MHz radios can be reprogrammed to any value between 902.200 MHz and 927.800 MHz, inclusive. The factory default setting is 915.000 MHz.

For the 2400 MHz radios, the test frequency can be programmed to any frequency between 2400.6 MHz and 2482.0 MHz. The default value is 2436.0 MHz.

UNIT [10000–65000]

Unit Address

This command sets the unit addressing for network-wide diagnostics and AT-Command address. The unit address is factory programmed to the last four digits of the radio's serial number. If re-programmed in the field, the entry must consist of five digits between 10000 and 65000.

XADDR [0–31]

Extended Address

Used to display or program the Extended Address of this radio that will serve as a common address for the sub-network synchronized to this Master or Extension. This value can be listed in the **XPRI** parameter of associated Extension or Remote radios to allow them to synchronize to this radio. We recommend setting the Master to zero (0). It is easy to remember, and is the default address when the INIT command is used. (Programmed only in Master and Extension radios.)

XMAP [00000000-FFFFFFFF]

Map of Extension Addresses

XMAP is a 32-bit hex entry where the least significant bit represents XADDR 0 and the most significant bit represents XADDR 31. The full 32-bit hex value represents the entire list of extensions with which the radio will be allowed to communicate. (Pertains to Remotes and Extensions only.)

This parameter is easily programmed through the *MDS TransNET Configuration Software's* **Store-and-Forward Settings** panel.

XPRI [0–31]

Primary Extended Address

Will display or program the extended address of the primary radio with which this radio will attempt to synchronize and communicate. A setting of **NONE** allows the unit to synchronize with any Master or Extension in the XMAP list. (Parameter only meaningful for Remote or Extension units.)

XRSSI [NONE, –40...–120]

Extension RSSI Level

The **XRSSI** command is used to set the RSSI minimum signal level required to preserve synchronization with a non-primary Extension radio. This parameter will be ignored if **XPRI** is set to **NONE**.

ZONE CLEAR

Clear Zone Statistics Log

The **ZONE CLEAR** command clears the zone data for *all* zones in the Zone Data Log, resetting the count to 0. (Zone data is also cleared automatically upon reboot.)

ZONE DATA

Read Zone Statistics Log

The transceiver divides its frequency operating spectrum into eight 3.0 MHz-wide zones or sub-bands. (These are the same zones referenced by the **SKIP** command described earlier.) Data frame statistics are maintained for each zone to indicate the transmission quality of data through the network. This information is useful for identifying zones where significant interference exists.

Historical information on the quality of each zone can be accessed using the **ZONE DATA** command. The report shows you the number of data frames sent, the number received, and the number received with errors. If an excessive number of errors are seen in one or more frequency zones, it may indicate interference, and you should consider “skipping” those zones using the **SKIP** command (See “**SKIP [NONE, 1...8]**” on Page 53).

Note: If a frequency zone has been skipped, all counts for that zone will be zeros.

The **ZONE DATA** format is displayed as follows:

```
1:TX TOTAL 00000000
1:RX TOTAL 00000000
1:RX ERROR 00000000
x:
x:
x:
8:TX TOTAL 00000000
8:RX TOTAL 00000000
8:RX ERROR 00000000
```

All data is based on payload packets. Incoming network data may be divided into multiple packets for over-the-air transfers. The number before the colon represents the zone. **TX TOTAL** is the transmit packet total. **RX TOTAL** is the receive packet total. **RX ERROR** is the total number of received packets with CRC errors. All zone data is reset with the **ZONE CLEAR** command.

9.0 TROUBLESHOOTING

Successful troubleshooting of a TransNET system is not difficult, but requires a logical approach. It is best to begin troubleshooting at the Master station, as the rest of the system depends on the Master for polling instructions and synchronization data. If the Master station has problems, the operation of the entire network will be affected.

When communication problems are found, it is good practice to begin by checking the basics. All radios in the network must meet these basic requirements:

- Adequate and stable primary power
- An efficient and properly aligned antenna system
- Secure connections (RF, data & power)

- Proper programming of the radio's operating parameters, especially Operating Mode (**MODE**), Network Address (**ADDR**), and interface Baud Rate (**BAUD**). For TransNET 2400 check the sub-band (**BAND**).
- The correct interface between the radio and the connected data equipment (proper cable wiring, data format and timing).
- In store-and-forward systems there are several areas that should be checked or evaluated:
 - Look for duplicate **XADDR** values on **MODE M** and **MODE X** radios. Duplicates will cause failures unless the radios are too far apart to hear each other.
 - Check for errors in the synchronization qualifiers, **XPRI** and **XMAP**, on corresponding Remote radios.
 - Verify **SAF** is enabled at the Master radio.

9.1 Alarm Codes

When an alarm condition exists, the transceiver creates an alarm code. These codes can be very helpful in resolving many system difficulties.

Checking for Alarms—STAT command

To check for the presence of alarms, enter **STAT**. If no alarms exist, the message **NO ALARMS PRESENT** appears at the top of the display.

If an alarm does exist, a two-digit alarm code (00–31) is displayed, and it is identified as a major or minor alarm. A brief description of the alarm is also given. Alarm codes and their meanings are listed in [Table 23](#).

If more than one alarm exists, the word **MORE** appears at the bottom of the screen; additional alarms can be viewed by pressing **ENTER**.

Major Alarms versus Minor Alarms

Major alarms report serious conditions that generally indicate a hardware failure, or other abnormal condition that will prevent (or seriously hamper) further operation of the transceiver.

With the exception of alarm code 00 (network address not programmed), major alarms generally indicate the need for factory repair.

Minor alarms report conditions which, under most circumstances, will not prevent transceiver operation. This includes out-of-tolerance conditions, baud rate mismatches, etc. The cause of these alarms should be investigated and corrected to prevent system failure.

Alarm Codes' Definitions

Table 23 contains a listing of all alarm codes that may be reported by the transceiver. Additional alarm codes may be used in future firmware releases or are used by the factory.





Table 23. Alarm Codes Descriptions

Alarm Code	Alarm Type	Description
00	Major	The network address is not programmed.
01	Major	Improper firmware detected for this radio model.
04	Major	One or more of the programmable synthesizer loops is reporting an out-of-lock condition.
08	Major	The system is reporting that it has not been calibrated. Factory calibration is required for proper radio operation.
10	Major	The DSP was unable to properly program the system to the appropriate defaults. A hardware problem may exist.
12	Major	Receiver time-out alarm.
16	Minor	The unit address is not programmed.
17	Minor	A data parity fault has been detected on the DATA connector. This usually indicates a parity setting mismatch between the radio and the RTU.
18	Minor	A data framing error has been detected on the DATA connector. This may indicate a baud rate mismatch between the radio and the RTU.
29	Minor	RF output power fault detected. (Power differs by more than 2 dB from set level.) Often caused by high antenna system SWR. Check antenna, feedline and connectors.
30	Minor	The system is reporting an RSSI reading below -105 dBm.
31	Minor	The transceiver's internal temperature is approaching an out-of-tolerance condition. If the temperature drifts outside of the recommended operating range and the transceiver may fail.

9.2 LED Indicators

The LED indicators on the transceiver board (CR3, CR-4, CR-5 and CR-6) are an important troubleshooting tool and should be checked whenever a problem is suspected. [Table 24](#) describes the function of each status LED.

Table 24. LED indicator descriptions

		LED Name	Description
		RXD (CR3) Receive Data	Serial receive data activity. Payload data from connected device.
RXD		TXD (CR4) Transmit Data	Serial transmit data activity. Payload data to connected device.
TXD		DCD (CR5) Data Carrier Detect	Continuous—Radio is receiving/sending synchronization frames On within 10 seconds of power-up under normal conditions
DCD		GP (CR6) General Purpose	<ul style="list-style-type: none"> • Continuous—Power is applied to the radio; no problems detected • Flashing (5 times-per-second)—Fault indication. See “TROUBLESHOOTING” on Page 57 • Off—Radio is unpowered or in Sleep mode
GP			

9.3 Troubleshooting Chart

Table 25 provides suggestions for resolving system difficulties that may be experienced in the radio system. If problems persist, contact the factory for further assistance. Refer to the inside back cover of this guide for contact information.

Table 25. Troubleshooting Guide

Difficulty	Recommended System Checks
Unit is inoperative.	<ul style="list-style-type: none"> a. Check for the proper supply voltage at the power connector. b. The transceiver's internal fuse may have opened.
Interference is suspected.	<ul style="list-style-type: none"> a. Verify that the system has a unique network address. Nearby systems with the same address will cause interference. b. Check for interference by locking out affected zone(s) using the SKIP command (Page 53). c. If omnidirectional antennas are used on Remote stations, consider changing to directional antennas. This will often limit interference to and from other stations.
No synchronization with Master, or poor overall performance.	<ul style="list-style-type: none"> a. Check for secure interface connections at the radio and the connected device. b. Check the antenna, feedline and connectors. Reflected power should be less than 10% of the forward power reading (SWR \approx 2:1 or lower). c. If the Remote radio is in synchronization, but performance is poor, check the received signal strength using the RSSI command (Page 50). If RSSI is low, it may indicate antenna problems, or misalignment of directional antenna headings. d. Verify proper programming of system parameters: mode, network address, data interface baud rate, transmitter power, CTS delay, etc. For store-and-forward applications, also verify the following: SAF is ON; extended address is properly programmed at each extension; Remotes are using the proper values for XPRI and XMAP. e. Check for alarms using the STAT command (Page 54)
BER is too high. Data throughput is spotty.	<ul style="list-style-type: none"> a. The RETRY and REPEAT commands may be increased to deal with interference, or decreased to increase throughput and reduce latency. b. Try turning on FEC. FEC on gives some coding gain, but comes at the cost of reduced throughput.
Latency is too high.	<ul style="list-style-type: none"> a. Reduce the REPEAT count. b. Turn BUFF OFF. BUFF ON ensures that no gaps occur in the data, but this comes at the cost of increased latency. c. Make sure HOPTIME is set to 7.

9.4 Performing Network-Wide Remote Diagnostics

Diagnostics data from a Remote radio can be obtained by connecting a laptop or personal computer running *MDS InSite* diagnostics software (Version 6.6 or later) to any radio in the network.

NOTE: The diagnostics feature may not be available in all radios. The ability to query and configure a radio via Network-wide Diagnostics is based on the feature options purchased in the radio being polled.

If a PC is connected to any radio in the network, intrusive polling (polling which briefly interrupts payload data transmission) can be performed. To perform diagnostics without interrupting payload data transmission, connect the PC to a radio defined as the “root” radio. A radio is defined as a root radio using the **DTYPE ROOT** command locally, at the radio.

A complete explanation of Remote diagnostics can be found in the *Network-Wide Diagnostics System Handbook* (Part No. 05-3467A01).

Table 26. Network-Wide Diagnostics Commands

Command	Description
DLINK [xxxxx/ON/OFF] <i>Details, page 44</i>	Set baud rate of diagnostics link
DTYPE [NODE/ROOT] <i>Details, page 45</i>	Set radio’s operational characteristics for network-wide diagnostics

1. Program one radio in the network as the root radio by entering the **DTYPE ROOT** command at the radio.
2. At the root radio, use the **DLINK ON** and **DLINK [baud rate]** commands to configure the diagnostic link protocol on the DIAG port.
3. Program all other radios in the network as nodes by entering the **DTYPE NODE** command at each radio.
4. Use the **DLINK ON** and **DLINK [baud rate]** commands to configure the diagnostic link protocol on the RJ-11 port of each node radio.
5. Connect a PC on which InSite software is installed to the root radio, or to one of the nodes, at the radio’s diagnostics port.
6. Launch the InSite application at the PC. (Refer to the InSite user’s manual for details.)

10.0 RADIO FIRMWARE UPGRADES

From time to time, GE MDS releases new firmware for its radio products. This file can be installed in existing radios to take advantage of engineering improvements or additional features.

10.1 Obtaining New Firmware

The latest firmware for each radio type may be obtained free from our Web site at:

www.GEMds.com

Registration may be required to access some downloadable files.

Firmware is also available on disks from the factory that are bundled with an installation utility (*MDS Radio Software Upgrade* (upgrade.exe) for transferring the firmware file on the disk to the radio.

Saving a Web-Site Firmware File Onto Your PC

Firmware upgrades are distributed as a plain-text (ASCII) file with a “.S28” extension. Browse the GE MDS Web site to find the desired “.S28” file for your radio. When you have found your selection, use the right mouse button to select a path on your computer on which to save the file. (If this isn’t done, your browser may display the firmware file contents as text on the screen instead of downloading it to your local hard drive.)

After the “.S28” file has been saved to your computer, you may use either *MDS TransNET Configuration Software* or *MDS Radio Software Upgrade programs* to install this firmware in your radios.

10.2 Installing Firmware Into Your Radio

1. Connect the PC to the radio’s diagnostics port.
2. Start the *MDS TransNET Configuration Software*. Open diagnostics port to the radio. The program will automatically read the radio’s profile.
3. From the **File** menu, select **Radio Firmware Upgrade** and follow the prompts to install the new firmware into the radio. Do not press the **Cancel** button once the installation has started or it will leave the radio without any code. When the installation is complete, another radio may be connected to your PC and programmed.

NOTE: If a firmware installation fails, the radio is left unprogrammed and inoperative. This is indicated by the PWR LED flashing slowly (1 second on/1 second off). This condition is only likely to occur if there is a power failure to the computer or radio during the installation process. The installation should be attempted again.

11.0 SECURITY

Today, the operation and management of an enterprise is becoming increasingly dependent on electronic information flow. An accompanying concern becomes the security of the communication infrastructure and the security of the data itself. We take this matter seriously, and provide several means for protecting the data carried over our wireless products.

Our radios address this issue primarily through the use of the following items:

- 1) A proprietary modem/data link layer—Data signals are processed using code and hardware specifically designed by the manufacturer.

- 2) A unique Network Address—This provides a unique identifier for each radio in a network. A radio is not addressable unless this unique code is included in the data string.
- 3) An optional encryption value (code)—Setting an encryption code requires the use of the **CODE** command. This command scrambles the radio’s hop pattern and encrypts payload data content. A radio requires the correct Network Address (**ADDR**) and **CODE** value in order to synchronize. When the **CODE** command is used, the same value must be programmed into all radios in the network. See “**CODE [NONE, 1...255]**” on Page 42 for more details.

The effective combination of **CODE** and **ADDR** discourage the use of an exhaustive search to gain access to a system.

The items described above provide sufficient security for most systems. For highly-sensitive applications, system designers should consider employing application level encryption into their polling protocols to further protect their systems. Third party software tools are available for adding encryption, and these should be considered as part of any advanced encryption scheme.

12.0 TECHNICAL REFERENCE

12.1 Product Specifications—900 MHz

GENERAL

Frequency Hopping Range:	902–928 MHz, Subdivided into eight 3.2 MHz zones
Hop Pattern:	Based on network address
Frequency Stability:	±1.5 ppm
Half-Duplex Operation:	±1.6 MHz TX/RX split
Network Addresses:	65,000
Temperature Range:	–40° C to +70° C
Humidity:	<95% at +40° C; non-condensing
Primary Power:	13.8 Vdc (6–30 Vdc range)
Current Draw (typical):	
Transmit:	510 mA @ 13.8 Vdc
Receive:	<115 mA @ 13.8 Vdc
Sleep Mode:	∅ 3 mA @ 13.8 Vdc
Physical Dimensions:	1.81” W x 3.45” L x 0.63” H (46 x 87.5 x 16 mm)
Agency Approvals:	<ul style="list-style-type: none"> • FCC Part 15.247 (E5MDS-EL806) • FCC Limited Modular Approval • Industry Canada RSS-210 and RSS-139 (CAN 3738A-MDSEL806)

DATA CHARACTERISTICS

Data Interface:	RS-232/422/485
Interface Connector:	16-pin header, female
Data Rate:	300, 600, 1200, 1800, 2400, 4800, 9600, 19200, 38400, 57600, 115200 bps asynchronous
Data Latency:	7 ms (typical)
Byte Length:	10 or 11 bits
Maximum Data Transmission:	Continuous up to 115200 bps

RF CHARACTERISTICS

TRANSMITTER:

Power Output (at antenna connector):	1.0 Watt (+30 dBm) Max.
Duty Cycle:	Continuous
Modulation Type:	Binary CPFSK
Output Impedance:	50 Ohms
Spurious:	-49 dBm, 216 MHz–960 MHz -41 dBm above 960 MHz

RECEIVER:

Type:	Double conversion superheterodyne
Sensitivity:	-105 dBm @ 1×10^{-6} BER
Intermodulation:	59 dB minimum (EIA)
Desensitization:	60 dB
Spurious:	60 dB minimum
Bandwidth:	200 kHz
Interference Ratio (SINAD degraded by 3dB):	Co-channel: -20 dB Adjacent channel: 0 dB Two channels away: +20 dB Three channels away: +30 dB

Time Required to Synchronize with Master Radio:	0.5 seconds (typical)
--	-----------------------

12.2 Product Specifications—2400 MHz

GENERAL

Frequency Hopping Range:	2401.6–2477.8 MHz ISM band A: 2401.6 MHz–2427.0 MHz B: 2427.2 MHz–2452.6 MHz C: 2452.8 MHz–2478.2 MHz Subdivided into eight 3.2 MHz zones
Hop Pattern:	Based on network address
Frequency Stability:	±1.5 ppm
Half-Duplex Operation:	±1.6 MHz TX/RX split
Network Addresses:	65,000

Temperature Range: -40° C to +70° C
 Humidity: <95% at +40° C; non-condensing
 Primary Power: 13.8 Vdc (6–30 Vdc range)

Current Draw (typical):
 Transmit: 510 mA @ 13.8 Vdc
 Receive: <115 mA @ 13.8 Vdc
 Sleep Mode: ⌀ 3 mA @ 13.8 Vdc
 Physical Dimensions: 1.81" W x 3.45" L x 0.63" H
 (46 x 87.5 x 16 mm)

Agency Approvals:

- FCC Part 15.247 (E5MDS-EL806-24)
- FCC Limited Modular Approval
- Industry Canada RSS-210 and RSS-139 (CAN 3738A-MDSEL80624)

DATA CHARACTERISTICS

Data Interface: RS-232/422/485
 Interface Connector: 16-pin header, female
 Data Rate: 300, 600, 1200, 1800, 2400, 4800, 9600, 19200, 38400, 57600, 115200 bps asynchronous
 Data Latency: 7 ms (typical)
 Byte Length: 10 or 11 bits
 Maximum Data Transmission: Continuous up to 115200 bps

RF CHARACTERISTICS

TRANSMITTER:

Power Output (at antenna connector): 0.5 Watt (+27 dBm) Max.
 Duty Cycle: Continuous
 Modulation Type: Binary CPFSK
 Output Impedance: 50 Ohms
 Spurious: -49 dBm, 216 MHz–960 MHz
 -41 dBm above 960 MHz

RECEIVER:

Type: Double conversion superheterodyne
 Sensitivity: -104 dBm @ 1 x 10⁻⁶ BER
 Intermodulation: 45 dB minimum (EIA)
 Desensitization: 60 dB
 Spurious: 60 dB minimum
 Bandwidth: 200 kHz
 Interference Ratio (SINAD degraded by 3dB):
 Co-channel: -40 dB
 Adjacent channel: 0 dB
 Two channels away: +20 dB
 Three channels away: +45 dB

Time Required to Synchronize
with Master Radio: 0.5 seconds (typical)

12.3 Transceiver Module’s Interface Connector, J3, Detailed Pin Descriptions

The tables in this section give detailed pin functions for the transceiver’s 16-pin header connector, J3 (see [Figure 16](#)). The tables are organized according to the available signaling configurations of the OEM transceiver. Signaling configuration is hardware fixed at the time of manufacture and will be one of the following:

- TTL signaling for *both* Payload and Diagnostic data
- Payload data TTL; Diagnostic data RS-232
- Payload data RS-232/RS-485 selectable; Diagnostic data RS-232

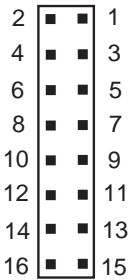

**Figure 16. 16-pin Header Connector (J3)
on OEM Transceiver Board**

(See parts list ([Page80](#)) for information on matching connector)

Table 27. Transceiver Connector J3 Pinouts
Payload data TTL; Diagnostic data TTL

Pin No.	Input/ Output	Signal Type	Name/Description
1	IN	—	Ground —Connects to ground (negative supply potential).
2	OUT	TTL, 3 Vdc	Diagnostic TXD —Supplies received diagnostic/administrative data to the connected device.
3	OUT	TTL, 3 Vdc	Alarm condition —A low indicates normal operation. A high indicates an alarm. (See ASENSE [HI/LO] command for more information.)
4	IN	TTL, 3 Vdc	Diagnostic RXD —Accepts diagnostic/administrative data from the connected device.
5	IN	—	DC Input (6–30 Vdc) — Supply Source must be capable of furnishing at least 7.5 watts.

Table 27. Transceiver Connector J3 Pinouts
Payload data TTL; Diagnostic data TTL (Continued)

6	IN	TTL, 3 Vdc	Sleep Mode Input —A ground on this pin turns off most circuits in a remote radio. This allows for greatly reduced power consumption, yet preserves the radio's ability to be brought quickly back on line. See "Using the Radio's Sleep Mode (Remote Units Only)" on Page 26 for details.
7	OUT	TTL, 3 Vdc	Data Carrier Detect (DCD) —A low indicates hopping synchronization has been achieved.
8	IN	TTL, 3 Vdc	Power Supply Shutdown Control —A ground on this pin causes the OEM module's power supply to shut down.
9	—	—	DC Input (Regulated 3.3 Vdc) —Supply Source must be capable of furnishing at least 7.5 watts.
10	IN	TTL, 3 Vdc	Transmitted Data (TXD) —Accepts payload data from the connected device.
11	IN	—	DC Input (6–18 Vdc) —Supply Source must be capable of furnishing at least 7.5 watts.
12	IN	TTL, 3 Vdc	Request to Send (RTS) —A high causes CTS to follow after the programmed CTS delay time has elapsed (DCE).
13	—	—	Reserved—Do not connect.
14	OUT	TTL, 3 Vdc	Received Data (RXD) —Supplies received payload data to the connected device.
15	IN	—	Ground —Connects to ground (negative supply potential).
16	OUT	TTL, 3 Vdc	Clear to Send (CTS) —Goes high after the programmed CTS delay time has elapsed (DCE), or keys an attached radio when RF data arrives (CTS KEY).

Table 28. Transceiver Connector J3 Pinouts
(Payload data TTL; Diagnostic data RS-232)

Pin No.	Input/Output	Signal Type	Name/Description
1	IN	—	Ground —Connects to ground (negative supply potential).
2	OUT	RS-232	Diagnostic TXD —Supplies received diagnostic/administrative data to the connected device.
3	OUT	TTL, 3 Vdc	Alarm condition —A low indicates normal operation. A high indicates an alarm. (See ASENSE [HI/LO] command for more information.)
4	IN	RS-232	Diagnostic RXD —Accepts diagnostic/administrative data from the connected device.



Table 28. Transceiver Connector J3 Pinouts
(Payload data TTL; Diagnostic data RS-232) (Continued)

5	IN	—	DC Input (6–30 Vdc) — Supply Source must be capable of furnishing at least 7.5 watts.
6	IN	TTL, 3 Vdc	Sleep Mode Input —A ground on this pin turns off most circuits in a remote radio. This allows for greatly reduced power consumption, yet preserves the radio’s ability to be brought quickly back on line. See “Using the Radio’s Sleep Mode (Remote Units Only)” on Page 26 for details.
7	OUT	TTL, 3 Vdc	Data Carrier Detect (DCD) —A low indicates hopping synchronization has been achieved.
8	IN	TTL, 3 Vdc	Power Supply Shutdown Control —A ground on this pin causes the OEM module’s power supply to shut down.
9	—	—	Reserved—Do not connect.
10	IN	TTL, 3 Vdc	Transmitted Data (TXD) —Accepts payload data from the connected device.
11	IN	—	DC Input (6–30 Vdc) — Supply Source must be capable of furnishing at least 7.5 watts.
12	IN	TTL, 3 Vdc	Request to Send (RTS) —A high causes CTS to follow after the programmed CTS delay time has elapsed (DCE).
13	—	—	Reserved—Do not connect.
14	OUT	TTL, 3 Vdc	Received Data (RXD) —Supplies received payload data to the connected device.
15	IN	—	Ground —Connects to ground (negative supply potential).
16	OUT	TTL, 3 Vdc	Clear to Send (CTS) —Goes high after the programmed CTS delay time has elapsed (DCE), or keys an attached radio when RF data arrives (CTS KEY).

Table 29. Transceiver Connector J3 Pinouts
Payload data RS-232; Diagnostic data RS-232

Pin No.	Input/Output	Signal Type	Name/Description
1	IN	—	Ground —Connects to ground (negative supply potential).
2	OUT	RS-232	Diagnostic TXD —Supplies received diagnostic/administrative data to the connected device.
3	OUT	TTL, 3 Vdc	Alarm condition —A low indicates normal operation. A high indicates an alarm. (See ASENSE [HI/LO] command for more information.)

Table 29. Transceiver Connector J3 Pinouts
Payload data RS-232; Diagnostic data RS-232 (Continued)

4	IN	RS-232	Diagnostic RXD —Accepts diagnostic/administrative data from the connected device.
5	IN	—	DC Input (6–30 Vdc) — Supply Source must be capable of furnishing at least 7.5 watts.
6	IN	TTL, 3 Vdc	Sleep Mode Input —A ground on this pin turns off most circuits in a remote radio. This allows for greatly reduced power consumption, yet preserves the radio’s ability to be brought quickly back on line. See “Using the Radio’s Sleep Mode (Remote Units Only)” on Page 26 for details.
7	OUT	TTL, 3 Vdc	Data Carrier Detect (DCD) —A low indicates hopping synchronization has been achieved.
8	IN	TTL, 3 Vdc	Power Supply Shutdown Control —A ground on this pin causes the OEM module’s power supply to shut down.
9	—	—	Reserved—Do not connect.
10	IN	RS-232, ± 5 Vdc	Transmitted Data (TXD) —Accepts payload data from the connected device.
11	IN	—	DC Input 6–30 Vdc) — Supply Source must be capable of furnishing at least 7.5 watts.
12	IN	RS-232, ± 5 Vdc	Request to Send (RTS) —A high causes CTS to follow after the programmed CTS delay time has elapsed (DCE).
13	—	—	Reserved—Do not connect.
14	OUT	RS-232, ± 5 Vdc	Received Data (RXD) —Supplies received payload data to the connected device.
15	IN	—	Ground —Connects to ground (negative supply potential).
16	OUT	RS-232, ± 5 Vdc	Clear to Send (CTS) —Goes high after the programmed CTS delay time has elapsed (DCE), or keys an attached radio when RF data arrives (CTS KEY).

Table 30. Transceiver Connector J3 Pinouts
Payload data RS-485; Diagnostic data RS-232

Pin No.	Input/Output	Signal Type	Name/Description
1	IN	—	Ground —Connects to ground (negative supply potential).
2	OUT	RS-232	Diagnostic TXD —Supplies received diagnostic/administrative data to the connected device.
3	OUT	TTL, 3 Vdc	Alarm condition —A low indicates normal operation. A high indicates an alarm. (See ASENSE [HI/LO] command for more information.)
4	IN	RS-232	Diagnostic RXD —Accepts diagnostic/administrative data from the connected device.
5	IN	—	DC Input (6–30 Vdc) — Supply Source must be capable of furnishing at least 7.5 watts.
6	IN	TTL, 3 Vdc	Sleep Mode Input —A ground on this pin turns off most circuits in a remote radio. This allows for greatly reduced power consumption, yet preserves the radio’s ability to be brought quickly back on line. See “Using the Radio’s Sleep Mode (Remote Units Only)” on Page 26 for details.
7	OUT	TTL, 3 Vdc	Data Carrier Detect (DCD) —A low indicates hopping synchronization has been achieved.
8	IN	TTL, 3 Vdc	Power Supply Shutdown Control —A ground on this pin causes the OEM module’s power supply to shut down.
9	—	—	Reserved—Do not connect.
10	IN	Differential	RXD+/RXA (Transmitted Data+) —Non-inverting receiver input. Accepts payload data from the connected device.
11	IN	—	DC Input (6–30 Vdc) — Supply Source must be capable of furnishing at least 7.5 watts.
12	IN	Differential	RXD-/RXA (Transmitted Data-) —Inverting receiver input.
13	—	—	Reserved—Do not connect.
14	OUT	Differential	TXD+/TXA (Received Data+) —Non-inverting driver output. Supplies received payload data to the connected device.
15	IN	—	Ground —Connects to ground (negative supply potential).
16	OUT	Differential	TXD-/TXA (Received Data-) —Inverting driver output.

12.4 User Configurable I/O Connections

Several connection points (eyelets) are provided within the transceiver near the INTERFACE connector (J3) that allow the user to facilitate unique integration requirements.

By jumpering eyelets, external functions (unconditioned I/O) may be communicated within the TransNET network using a Network Management System (NMS) such as InSite or a user's custom application that uses the Network-Wide Diagnostics Protocol. Specifications for this protocol are open and are contained within the InSite distribution material on CD and on the GE MDS Web site.

CAUTION
POTENTIAL
EQUIPMENT
DAMAGE

Care should be taken when soldering to the PCB eyelets due to their small size. For this reason, only qualified personnel should install the jumpers and external connections.

Installation of internal jumpers and connection to non-standard interface pins may void the product's warranty.

If you are uncertain of your interface design, please consult with the GE MDS Technical Services Department for a review of your design to assure maintenance of your warranty.

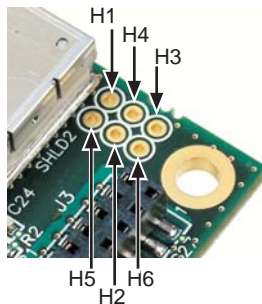

Figure 17. User Interface I/O Jumper Eyelets
PCBs 03-4050A01, Rev. B and later

NOTE: If your PCB does not look like the one in the [Figure 17](#), consult with the GE MDS Technical Services for assistance.

Each pin connected to user-designed equipment must be connected through a special cable constructed to breakout the User I/O pins.

Your interface can complement your unique requirements. The input signals and output interface must be within the radio's interface parameters as summarized in [Table 31](#).

Table 31. TransNET User I/O Connection Resources

Function or Service	Range	Available at eyelet:
Filtered Receive Audio (For test purposes)	0 – 5 Vac, 30–5 kHz	H2
General Purpose I/O 1 (GPIO 1) ^a	TTL; External 10K to 3.3 V Vcc Recommended	H3
General Purpose I/O 2 (GPIO 2) ^b	TTL; External 10K to 3.3 V Vcc Recommended	H4
Analog 1 ^c	0 – 5 Vac, δ 60 HZ	H6
<i>Do not connect. Factory use only.</i>		H5
Data Interface Pin		Available at eyelet:
DB-9, Pin 9		H1
RJ-11, Pin 1		H7
RJ-11, Pin 2		H8
RJ-11, Pin 3		H9

a. Configuration and data retrievable via MDS InSite™ software as “I/O 1”

b. Configuration and data retrievable via MDS InSite™ software as “I/O 2”

c. Parameter retrievable via MDS InSite™ software

Using the I/O Points with InSite™ NMS Software

InSite software has the ability to read the user analog input (**Analog 1**) and two user-configurable and independent I/O signals (**I/O 1 & I/O 2**). Each I/O connection can independently configured as input or output. If configured as an output, a *saved* default output value can be stored in the radio to ensure the radio boots to the desired state for this pin.

The values of **I/O 1 & I/O 2** can be read and displayed by an InSite user to determine the current state. The values of **I/O 1 & I/O 2** at the TransNET’s DATA Interface connector will remain in a constant state until manually changed though the InSite **Configuration** screen.

Application Example—Digital Input/Output at Remote

A typical application of the user I/O connections may require one digital input and one digital output to be controlled by network diagnostics. In this example, H3 could be jumpered to H7 (I/O 1 to RJ-11, Pin 1) and H4 jumpered to H8 (I/O 2 to RJ-11, Pin 2). Using InSite, **I/O 1** could be configured as an output and **I/O 2** as an input.

13.0 EVALUATION DEVELOPMENT KIT (P/N 03-4053A01)

The Evaluation Development Kit is designed to assist integrators who will be working with the transceiver in a benchtop setting. The kit contains the following:

- Two OEM Transceiver modules (configured for TTL, or RS-232/485 operation, as requested)
- Two Evaluation Development boards (P/N 03-4051A01)
- Interface Cables
- Two whip antennas
- Two 12 Vdc power supplies
- TransNET Support CD containing software for programming & diagnostics

Evaluation PC Board

A key part of the Evaluation Development Kit is the Evaluation Board shown in [Figure 18](#). It contains a 16-pin header connector (J2) that mates with female connector J3 the OEM transceiver board. It carries all signals (except RF) between the Evaluation Board and the transceiver module. The Evaluation PCB is compatible with TTL and RS-232/485 configured radios mounted on it. [Table 34](#) lists the basic pin functions of J2.

The Evaluation Board provides convenient connection points for diagnostics, payload data, and DC power. Each of these connectors are discussed in this section. The board also includes a series of test probe points to the left of J2. These may be used for monitoring logic signal activity with a multimeter, DVM, oscilloscope or other test instruments. The probe points are identified by printed markings on the board.

The transceiver board's RF/Antenna connection is *not* connected to the Evaluation Board's 16-pin header. The transceiver module's antenna connection is always made at J200 or J201 using a complementary connector.

For more detailed pinout information on the transceiver module's Interface, J3, including the differences between TTL and RS-232/485 configured radios, refer to [Section 12.3 on Page 66](#).

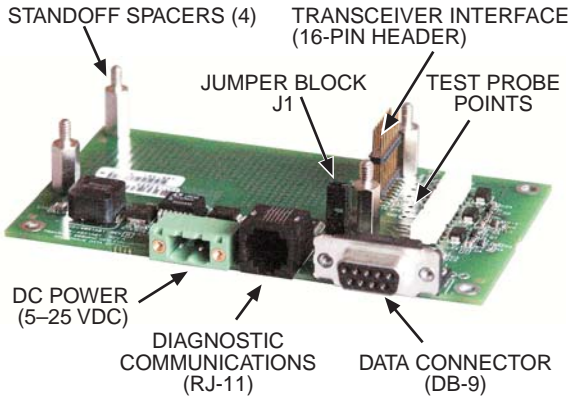

Figure 18. OEM Evaluation Board (P/N 03-4051A01)

For detailed information on the transceiver module's Interface connector, J3, review the series of tables beginning on [Page 66](#).

Connecting the Transceiver & Evaluation Board

To connect the Evaluation Board to the radio as shown in [Figure 19](#), carefully align the pins of the 16-pin header with J3 on the transceiver module and press down firmly. The radio PC board should seat solidly on the four standoff spacers. Use nuts to secure the board to the standoffs.

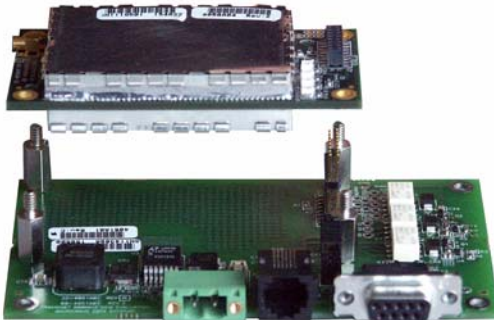

Figure 19. Connecting the Transceiver (upper PCB) and Evaluation Board (lower PCB) Together

CAUTION: Take care to avoid short-circuiting the underside of the Evaluation PC board. The bottom of the board is *not* insulated, and contact with metallic objects on the work surface could cause damage to the board or connected equipment.

13.1 Cable Connections for Benchtop Testing

There are four basic requirements for operating the transceiver and evaluation board in a benchtop test environment. They are:

- Adequate and stable primary power
- A proper antenna system or RF load (50 Ohms)
- The correct interface wiring between the transceiver and the connected DTE device (RTU, PLC, etc.)
- A connected PC terminal to read/set transceiver parameters.

Figure 20 shows a typical setup for bench testing an OEM Transceiver. Two such setups will be required if you intend to establish over-the-air communications with another OEM transceiver.

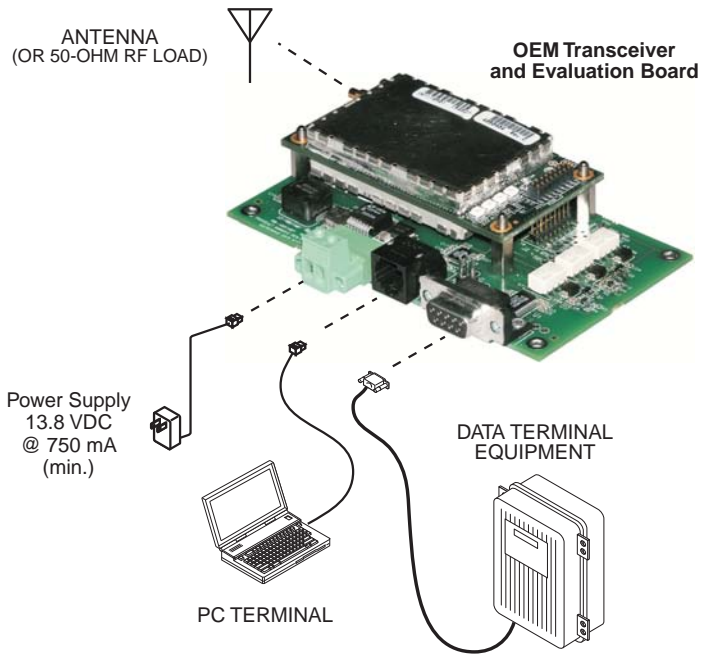

Figure 20. Typical Test Setup

Antenna Connection—Transceiver Module, J200/201

Antenna connector is located at the edge of the transceiver module on the side opposite the Interface connector, J3. The connector can be one of several sub-miniature RF coaxial connectors as listed in [Table 3 on Page 6](#). Connect an antenna or other suitable RF load to this connector. Only approved antenna/cable assemblies may be used with the radio.

CAUTIONPOSSIBLE
EQUIPMENT
DAMAGE

Do not apply DC power to the transceiver without first attaching a proper RF load, or the transceiver may be damaged.

DC Power Connector, J3

This connector accepts operating power for the transceiver. A wall-style AC adapter (Part No. 01-3862A02) is recommended for this service.

DC connection is made with a 2-pin polarized plug, GE MDS Part No. 73-1194A39. Be sure to observe proper polarity. **The left terminal is positive (+) and the right is negative (-).** (See [Figure 21](#)).

CAUTIONPOSSIBLE
EQUIPMENT
DAMAGE

The radio transceiver and OEM Evaluation PCB must be used only with negative-ground systems operating between 6 and 30 Vdc. Make certain that the polarity of the power source is correct.

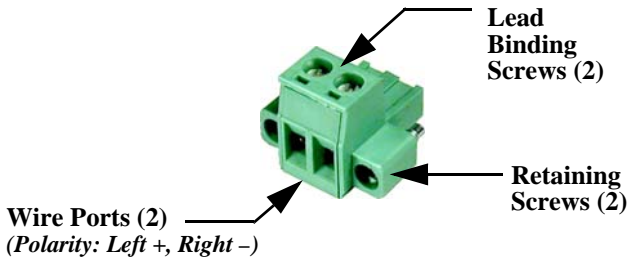

Figure 21. DC Power Connector (P/N 73-1194A39)

NOTE: Although the power connector used on the OEM Evaluation Board resembles those used by some earlier MDS transceivers, such as the MDS 9810 and x710 family, the connectors are *not* equal and the use of the wrong plug will provide unreliable connections. Only the power connector shown in [Figure 21](#) with screw terminals and two retainer screws should be used with the OEM Evaluation Board.

Diagnostic Connection, J4

J4 is an RJ-11-6 modular connector used to connect the evaluation board/transceiver to a PC terminal for programming and interrogation. An RJ-11 to DB-9 Adapter Cable (Part No. 03-3246A01) is required for this connection. If desired, an cable may be constructed for this purpose as shown in [Figure 22](#). Only Pins 4, 5, and 6 of the RJ-11 connector should be used. Pins 1, 2, and 3 are reserved for factory test purposes.)

The data parameters of the diagnostics port are as follows: 8 data bits, 1 stop bit, and no parity. It automatically configures itself to function at 1200, 2400, 4800, 9600, 19200, 38400, 57600, and 115200 bps, as required.

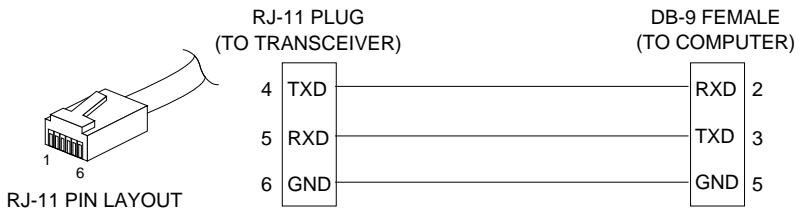

Figure 22. RJ-11 to DB-9 Diagnostic Cable—Wiring Details
(A pre-constructed cable is also available, Part No. 03-3246A01)

Diagnostic Communication Modes

Two methods may be used to communicate with the radio’s diagnostic port:

- **Terminal Interface**—The PC is used in its basic terminal emulation mode, (i.e., HyperTerminal session) and commands are issued as simple text strings.
- **Radio Configuration Software**—Proprietary software from the factory that runs under the Windows operating system. It provides a graphical user interface with “point and click” functionality. The program is included on the *TransNET Support Package* CD shipped with every radio order.

Both of these control methods are described in more detail in the section titled **“RADIO PROGRAMMING”** on Page 33. This section also includes a chart listing all commands for the OEM transceiver.

DATA Connector, J5

J5 on the Evaluation Board (Figure 23) is the data interface for the transceiver. J5 is used to connect the transceiver to an external DTE terminal that supports only EIA/RS-232 signalling at speeds which are dependent on the radio data rate of either 300, 600, 1200, 1800, 2400, 4800, 9600, 19200, 38400, 57600, or 115200 bps (asynchronous only). The connector mates with a standard DB-9 plug available from many electronics parts suppliers.

DATA Wiring Connections

The connections made to J5 will depend on the requirements of the DTE device being used with the transceiver, and the operating functions that you require. Only the required pins for the application should be used. Do not use a straight through “computer” type cable that is wired pin-for-pin.

Typical RS/EIA-232 applications require the use of Pin 2 (receive data—RXD) and Pin 3 (transmit data—TXD). Additionally, some systems may require the use of Pin 7 (Request-to-send—RTS). If hardware flow control is desired, Pin 7 (RTS) and Pin 8 (CTS) may also need connection.

Table 32 gives pin details for radios configured for RS/EIA-232 service.

NOTE: Radio modules equipped with a payload TTL interface are presented as RS-232 mode from the Evaluation Board.

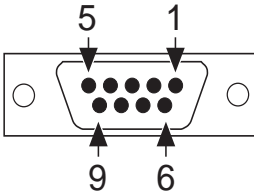

Figure 23. DATA Connector (DB-9F), J5
As viewed from outside the device

Table 32 lists the DATA connector pin functions for an RS/EIA-232 signaling interface.

NOTE: The radio is hard-wired as a DCE in the EIA-232 mode.

Table 32. DATA Connector, J5, Pin Descriptions—RS/EIA-232

Pin Number	Input/Output	Pin Description
1	—	Eyelet H11, Evaluation PCB
2	OUT	RXD (Received Data) —Supplies received data to the connected device.
3	IN	TXD (Transmitted Data) —Accepts TX data from the connected device.
4	—	Eyelet H13, Evaluation PCB
5	IN	Signal Ground —Connects to ground (negative supply potential) on the radio’s PC board and chassis.
6	—	Eyelet H12, Evaluation PCB
7	IN	RTS (Request-to-Send)
8	OUT	CTS (Clear-to-Send) —Goes “high” after the programmed CTS delay time has elapsed (DCE), or keys an attached radio when RF data arrives (CTS KEY).
9	—	Eyelet H14, Evaluation PCB

Unterminated Pins

Four pins of the DB-9 DATA Interface connector, J5, on the Evaluation PCB are available for custom connections.

Figure 17 shows the location of eyelets connected to the Evaluation PCB’s DATA interface connector, J5. These pins are provided for low-current and low-voltage connections.

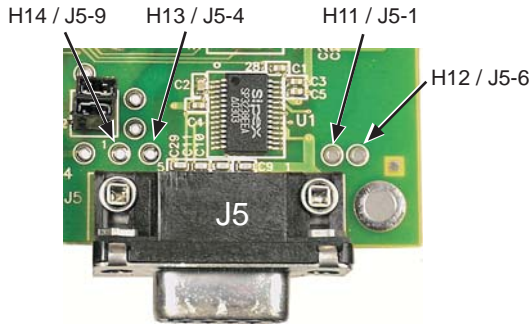

**Figure 24. Evaluation PCB's DATA Interface, J5,
Underterminated Pins Eyelets**
PCBs 03-4051A01, Rev. B and later

Transceiver Power Interface, J1

Terminal block, J1, on the Evaluation PCB, provides direct access to the two power lines feeding the transceiver module—unregulated primary power (6–30 Vdc) and regulated 3.3 Vdc.

These jumpers and nearby eyelets can be used for two functions: 1. Measure the module current consumption under various operating conditions by inserting an inline ammeter, and 2. To bypass the Evaluation PCB's 3.3 Vdc regulator to connect your own power source.

With the jumpers removed, the pins of J1 can be used as convenient points to measure the regulated and unregulated power supplied to the OEM module.

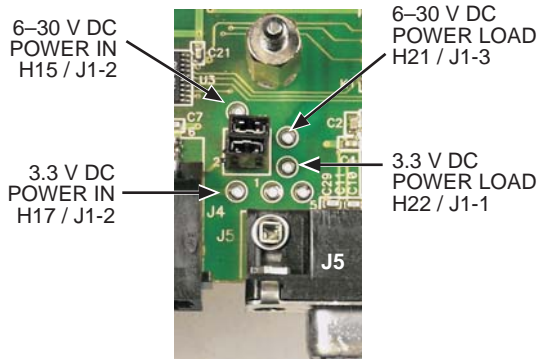

Figure 25. J1, Transceiver Power Eyelets

NOTE: Jumper J1 does not normally require any change by the user for basic operation of the transceiver module on the Evaluation PCB. Both jumper plugs are normally installed on J1.

13.2 Evaluation PCB Documentation

This section contains an assembly drawing and parts list for the OEM Evaluation Board. In addition, a separate foldout schematic of the Board is included at the back of this manual. Board documentation is provided to assist integrators who need to create compatible interface circuitry between the OEM transceiver and host equipment.

Assembly Drawing

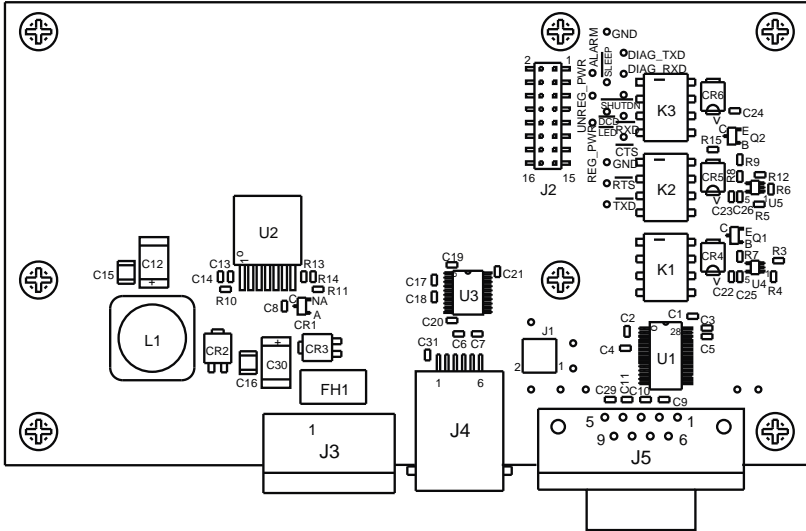

Figure 26. Evaluation Board Assembly Diagram

Parts List

Table 33 lists the electronic components used on the Evaluation Board.

Table 33. OEM Evaluation Board Parts List

Ref. Desig.	Part Description
CR1	DIODE, SOT23 SMALL SIG 914 5D
CR4 CR5 CR6	RECTIFIER, 30V B13
CR2 CR3	DIODE, SCHOTTKY POWER, SMT, SNGL, UPS840
Q1 Q2	TRANSISTOR, SOT23 NPN 6429 M1LR
U4 U5	IC, LINEAR SC70-5 COMPARATOR SINGLE LMV33
U1	IC, IN'FACE SSOP28 RS-232 TXVR SP3238E

Table 33. OEM Evaluation Board Parts List (Continued)

U3	IC, IN'FCE 20PIN TSSOP DRIVER SP3222
U2	IC, SWITCHING REG'R ADJ.4.5A LT1374HVIR
K1 K2 K3	RELAY, DPDT
R10	RESISTOR, CHIP 0603 1/16W 5% 2.2K
R4 R5 R13 R14	RESISTOR, CHIP 0603 1/10W 1% 10K
R12	RESISTOR, CHIP O603 1/10W 1% 100K
R7 R9	RESISTOR, CHIP 0603 1/10W 1% 1.5K
R11	RESISTOR, CHIP O603 1/10W 1% 1.82K
R3	RESISTOR, CHIP 0603 1/10W 1% 22.6K
R15	RESISTOR, CHIP O603 1/10W 1% 31.6K
R8	RESISTOR, CHIP 0603 1/10W 1% 470 OHM
R6	RESISTOR, CHIP O603 1/10W 1% 6.81K
C12	CAP, TANT 7343 20% 10V 100uf
C6 C7 C9 C10 C11 C29 C31	CAP, CHIP 0603 50V NPO 5% 100pf
C1 C2 C3 C4 C5 C17 C18 C19 C20 C21 C22 C23 C24 C25 C26 C8	CAP, CHIP 0603 X7R 10% 0.1uF
C13	CAP, CHIP 0603 X7R 10% 470 pF
C14	CAP, CHIP 0603 X7R 10% 4700pF
C15	Capacitor, Low ESR Chip Ceramic, 1210 22uF
C16	Capacitor, Low ESR Chip Ceramic, 1210 4.7
L1	INDUCTOR, SWITCHING, 20%, 10uH
J1	CONN, HEADER, 0.100 DUAL STR 4-PIN
P/O J1 1-2, P/O J1 3-4	CONN, JUMPER
FH1	FUSE HOLDER, PCB SMT W/2A SLO-BLO FUSE
J2	CONN, HEADER, PC MOUNT 0.078, DUAL, 16 PIN Samtec TW Series, Part No: ASP 103812-01 (Mates with J3 on the OEM radio transceiver)
J3	CONN, TERM STRIP, 5MM PCB
J4	CONN, TELE JACK 6POS 6CON RT A SMT W/F
J5	CONN, D-SUB, PCB RCPT 90 DEGREE, 9 PIN

Evaluation PCB Interface to Transceiver PCB, J2

Table 34, lists the signal and power lines passed between the Evaluation PCB and the transceiver module. Only a few functions are passed through to the Evaluation PCB's DATA interface connector, J5. However, many of the pins of J2 are available through eyelets near the connector as seen in Figure 26 on Page 80.

**Table 34. Transceiver Interface, J2
(16-Pin Header Connector on Evaluation PCB)**

Pin No.	Pin Function
1	Ground
2	Diagnostic TXD
3	Alarm Condition
4	Diagnostic RXD
5	DC Input
6	Sleep Mode Input
7	Data-Carrier Detect (DCD)
8	Power Supply Shutdown Control
9	Reserved—Do not connect.
10	Transmitted Payload Data (TXD)
11	DC Input
12	Request-to-Send (RTS)
13	Reserved—Do not connect.
14	Received Payload Data (RXD)
15	Ground
16	Clear-to-Send (CTS)

For detailed descriptions of the functions of the interface connector from the transceiver's point-of-view, see “[Transceiver Module's Interface Connector, J3, Detailed Pin Descriptions](#)” on Page 66.

PCB Schematic

The foldout schematic found in the rear of this manual can also be found in the TransNET Support Package CD-ROM, and from our Web site at: www.GEmds.com.

13.3 Evaluation Board Fuse Replacement

The Evaluation Board is protected by a 2-Ampere fuse. The fuse can be blown by an over-current condition caused by an internal failure or over-voltage. Follow the procedure below to remove and replace the fuse:

1. Disconnect the primary power cable and all other connections to the Evaluation Board.
2. Locate the fuse holder assembly, FH1, behind the green power connector, J3.
3. Loosen the fuse from the holder using a very small screwdriver, then use a small pair of needle-nose pliers to pull the fuse straight up and out of the holder.
4. Use an ohmmeter or other continuity tester to verify that the fuse is open.
5. Install a new fuse in the holder. Replacement fuse information: Littelfuse #0454002; 452 Series, 2 Amp SMF Slo-Blo fuse (GE MDS Part No. 29-1784A03).

14.0 dBm-Watts-Volts CONVERSION CHART

Table 35 is provided as a convenience for determining the equivalent voltage or wattage of an RF power expressed in dBm with 50 Ohms load.

Table 35. dBm-Watts-Volts Conversion Chart

dBm	V	Po	dBm	V	Po	dBm	mV	Po	dBm	μV	Po
+53	100.0	200W	0	.225	1.0mW	-49	0.80		-98	2.9	
+50	70.7	100W	-1	.200	.80mW	-50	0.71	.01μW	-99	2.51	
+49	64.0	80W	-2	.180	.64mW	-51	0.64		-100	2.25	.1pW
+48	58.0	64W	-3	.160	.50mW	-52	0.57		-101	2.0	
+47	50.0	50W	-4	.141	.40mW	-53	0.50		-102	1.8	
+46	44.5	40W	-5	.125	.32mW	-54	0.45		-103	1.6	
+45	40.0	32W	-6	.115	.25mW	-55	0.40		-104	1.41	
+44	32.5	25W	-7	.100	.20mW	-56	0.351		-105	1.27	
+43	32.0	20W	-8	.090	.16mW	-57	0.32		-106	1.18	
+42	28.0	16W	-9	.080	.125mW	-58	0.286				
+41	26.2	12.5W	-10	.071	.10mW	-59	0.251				
+40	22.5	10W	-11	.064		-60	0.225	.001μW	dBm	nV	Po
+39	20.0	8W	-12	.058		-61	0.200		-107	1000	
+38	18.0	6.4W	-13	.050		-62	0.180		-108	900	
+37	16.0	5W	-14	.045		-63	0.160		-109	800	
+36	14.1	4W	-15	.040		-64	0.141		-110	710	.01pW
+35	12.5	3.2W	-16	.0355					-111	640	
+34	11.5	2.5W				dBm	μV	Po	-112	580	
+33	10.0	2W	dBm	mV	Po	-65	128		-113	500	
+32	9.0	1.6W	-17	31.5		-66	115		-114	450	
+31	8.0	1.25W	-18	28.5		-67	100		-115	400	
+30	7.10	1.0W	-19	25.1		-68	90		-116	355	
+29	6.40	800mW	-20	22.5	.01mW	-69	80		-117	325	
+28	5.80	640mW	-21	20.0		-70	71	.1nW	-118	285	
+27	5.00	500mW	-22	17.9		-71	65		-119	251	
+26	4.45	400mW	-23	15.9		-72	58		-120	225	
+25	4.00	320mW	-24	14.1		-73	50		.001pW		
+24	3.55	250mW	-25	12.8		-74	45		-121	200	
+23	3.20	200mW	-26	11.5		-75	40		-122	180	
+22	2.80	160mW	-27	10.0		-76	35		-123	160	
+21	2.52	125mW	-28	8.9		-77	32		-124	141	
+20	2.25	100mW	-29	8.0		-78	29		-125	128	
+19	2.00	80mW	-30	7.1	.001mW	-79	25		-126	117	
+18	1.80	64mW	-31	6.25		-80	22.5	.01nW	-127	100	
+17	1.60	50mW	-32	5.8		-81	20.0		-128	90	
+16	1.41	40mW	-33	5.0		-82	18.0		-129	80	.1fW
+15	1.25	32mW	-34	4.5		-83	16.0		-130	71	
+14	1.15	25mW	-35	4.0		-84	14.1		-131	61	
+13	1.00	20mW	-36	3.5		-85	12.9		-132	58	
+12	.90	16mW	-37	3.2		-86	11.5		-133	50	
+11	.80	12.5mW	-38	2.85		-87	10.0		-134	45	
+10	.71	10mW	-39	2.5		-88	9.0		-135	40	
+9	.64	8mW	-40	2.25	.1μW	-89	8.0		-136	35	
+8	.58	6.4mW	-41	2.0		-90	7.1	.001nW	-137	33	
+7	.500	5mW	-42	1.8		-91	6.1		-138	29	
+6	.445	4mW	-43	1.6		-92	5.75		-139	25	
+5	.400	3.2mW	-44	1.4		-93	5.0		-140	23	.01fW
+4	.355	2.5mW	-45	1.25		-94	4.5				
+3	.320	2.0mW	-46	1.18		-95	4.0				
+2	.280	1.6mW	-47	1.00		-96	3.51				
+1	.252	1.25mW	-48	0.90		-97	3.2				



GLOSSARY

Antenna System Gain—A figure, normally expressed in dB, representing the power increase resulting from the use of a gain-type antenna. System losses (from the feedline and coaxial connectors, for example) are subtracted from this figure to calculate the total antenna system gain.

ARQ—Automatic Repeat Request. An error-correction technique whereby flawed data packets are detected and a request for re-transmission is issued.

Bit—The smallest unit of digital data, often represented by a one or a zero. Eight bits (plus start, stop, and parity bits) usually comprise a byte.

Bits-per-second—*See BPS.*

BPS—Bits-per-second. A measure of the information transfer rate of digital data across a communication channel.

Byte—A string of digital data usually made up of eight data bits and start, stop, and parity bits.

Cyclic Redundancy Check (CRC)—A method to detect and correct errors by adding bits derived from a data packet, or string of bits, to the packet. The CRC value is used at the receiving end to evaluate the data packet integrity, and if it is not, the receiver will request a retransmission.

Decibel (dB)—A measure of the ratio between two signal levels. Frequently used to express the gain (or loss) of a system.

Data Circuit-terminating Equipment—*See DCE.*

Data Communications Equipment—*See DCE.*

Data Packet—A group of data bytes of various lengths to be sent over-the-air. Each packet contains a header (preamble) followed by the data bytes. Packet size will depend on network protocol and/or

Data Terminal Equipment—*See DTE.*

dB_i—Decibels referenced to an “ideal” isotropic radiator in free space. Frequently used to express antenna gain.

dB_m—Decibels referenced to one milliwatt. An absolute unit used to measure signal power, as in transmitter power output, or received signal strength.

DCE—Data Circuit-terminating Equipment (or Data Communications Equipment). In data communications terminology, this is the “modem” side of a computer-to-modem connection. By default, GE MDS transceivers are set as DCE devices.

Digital Signal Processing—*See DSP.*

DSP—Digital Signal Processing. DSP circuitry is responsible for the most critical real-time tasks; primarily modulation, demodulation, and servicing of the data port.



DTE—Data Terminal Equipment. A device that provides data in the form of digital signals at its output. Connects to the DCE device.

Equalization—The process of reducing the effects of amplitude, frequency or phase distortion with compensating networks.

Extended Address—A user-selectable number between 0 and 31 that identifies a group of transceivers that are part of a common sub-network. It is recommended the Master be assigned XADDR 0 and the values of 1-31 assigned to Extension radios.

Extension Radio—A radio in a TransNET spread-spectrum network that serves as a gateway between vertically adjacent sub-networks. *See Store-and-Forward.*

Fade Margin—The greatest tolerable reduction in average received signal strength that will be anticipated under most conditions. Provides an allowance for reduced signal strength due to multipath, slight antenna movement or changing atmospheric losses. A fade margin of 20 to 30 dB is usually sufficient in most systems.

Flow Control—A technique to manage incoming serial data to prevent buffer overflow and provide maximum over-the-air data transfers. This service can be provided through a collaboration of hardware and/or data protocol.

Frame—A segment of data that adheres to a specific data protocol and contains definite start and end points. It provides a method of synchronizing transmissions.

Frequency Hopping—The spread spectrum technique used by the transceiver, wherein two or more associated radios change their operating frequencies several times per second using a set pattern. Since the pattern appears to jump around, it is said to “hop” from one frequency to another.

Frequency Zone—The transceivers use up to 128 discrete channels in the 902 to 928 MHz spectrums. A group of 16 channels is referred to as a zone. The transceivers use five to eight frequency zones.

Hardware Flow Control—A transceiver feature used to prevent data buffer overruns when handling high-speed data from the RTU or PLC. When the buffer approaches overflow, the radio drops the clear-to-send (CTS) line, which instructs the RTU or PLC to delay further transmission until CTS again returns to the high state.

Host Computer—The computer installed at the master station site, which controls the collection of data from one or more remote sites.

Latency—The delay (usually expressed in milliseconds) between when data is applied to TXD (Pin 2) at one radio, until it appears at RXD (Pin 3) at the other radio.

MAS—Multiple Address System. A radio system where a central master station communicates with several remote stations for the purpose of gathering telemetry data.

Master (Station)—The one radio transceiver in a spread spectrum network that automatically provides synchronization information to one or more associated remote transceivers. A radio may be programmed for either master or remote mode using software commands.

Multiple Address System (MAS)—*See Point-Multipoint System.*

Network Address—User-selectable number between 1 and 65000 that is used to identify a group of transceivers that form a communications network. The master and all remotes within a given system must have the same network address.

Point-Multipoint System—A radio communications network or system designed with a central control station that exchanges data with a number of remote locations equipped with terminal equipment.

Poll—A request for data issued from the host computer (or master PLC) to a remote radio.

PLC—Programmable Logic Controller. A dedicated microprocessor configured for a specific application with discrete inputs and outputs. It can serve as a host or as an RTU.

Remote Radio—A radio in a spread spectrum network that communicates with an associated master station. A radio may be programmed for either master or remote mode using software commands.

Remote Terminal Unit—*See RTU.*

Repeater—A radio that receives RF data and retransmits it. *See Store-and-Forward.*

RTU—Remote Terminal Unit. A data collection device installed at a remote radio site.

SCADA—Supervisory Control And Data Acquisition. An overall term for the functions commonly provided through an MAS radio system.

Standing Wave Ratio—*See SWR.*

Sub-Network—A group of transceivers and the corresponding radio that they are directly synchronized to. A sub-network can be identified by Extended Address. *See Store-and-Forward.*

Store-and-Forward—A radio that receives RF data and retransmits it. In the TransNET product line, store and forward is defined as a network that consists of vertically adjacent sub-networks that alternate communicating upstream and downstream. The transceiver performs store and forward at the internal data frame level (not the user data level) which allows the equipment to stream data with minimal latency through each Extension/Repeater radio station.

SWR—Standing Wave Ratio. A parameter related to the ratio between forward transmitter power and the reflected power from the antenna system. As a general guideline, reflected power should not exceed 10% of the forward power ($\approx 2:1$ SWR).



TTL—Transistor-Transistor Logic. A form of digital switching that utilizes bipolar transistors to sense “high” and “low” logic levels (1 and 0, respectively).

Transmission Latency—Time required to send a single packet of data to the receiving end of the circuit. This value will depend on the baud rate and number of bytes in the sequence.

Zone—See Frequency Zone.

INDEX

A

- Accessories (table) 6
- ADDR command (set/display radio network address) 41
- Alarm
 - checking for 58
 - code definitions 59
 - codes 58
 - codes, table 59
 - major vs. minor 59
 - receiver timeout (RXTOT command) 52
 - reset output signal 42
 - set/display output sense (ASENSE command) 42
 - status (STAT command) 55
- ALARM command (superseded; see STAT command) 55
- Alarm Mask (AMASK) Command 42
- Alarm Sense (ASENSE) Command 42
- Alarm Status Command (STAT) 55
- AMASK command (configure alarm output signal) 42
- Antenna
 - performance optimization 15
 - selection 13
 - SWR check 16
 - system gain vs. power output setting, table 18
 - Yagi, illustrated 14
- ASENSE command (set/display alarm output sense) 42

B

- BAUD command (set/display data interface port attributes) 42
- Baud rate
 - setting 17
 - setting for RJ-11 DIAG port (DLINK command) 62
- Benchtop Setup & Evaluation 7–11
- BUFF command (set/display received data handling mode) 43

C

- Cable
 - data equipment to DATA

- INTERFACE connector 34
 - data interface wiring for tail-end links 10, 20
 - feedlines 14
- Clear Zone Statistics Log, ZONE CLEAR 57
- Clear-to-Send Delay (CTS) Command 44
- Clear-to-Send Hold Time (CTSHOLD) Command 44
- Clock-Synchronizing Master Address (CSADDR) Command 44
- CODE command (display/set encryption value) 43
 - Command 48
 - TEMP (radio's internal temperature reading) 56
- Commands
 - ADDR (set/display radio network address) 41
 - AMASK (configure alarm output signal) 42
 - ASENSE (set/display alarm output sense) 42
 - BAUD (set/display data interface port attributes) 42
 - BUFF (set/display received data handling mode) 43
 - CODE (set/display encryption value), See also Encryption 43
 - CTS (set/display CTS line response timer) 44
 - CTSHOLD (set/display CTS hold timer) 44
 - detailed descriptions 41–57
 - DEVICE (set/display DCE or CTS Key behavior) 45
 - display operating status 37
 - DKEY Command, Turn off radio transmitter test signal 45
 - DTYPE (set radio's diagnostics type) 46
 - FEC (Forward Error Correction) 46
 - FEC (Forward Error Correction) Command 46
 - HOPTIME (set/display hoptime setting) 46
 - how used 41
 - INIT (restore factory default settings) 46



LPM (low-power mode) 48
LPMHOLD (low-power mode sleep time) 49
MODE (display/set radio mode as master, remote, or extension) 49
MODE (radio operating mode) 49
most often used commands 41
network configuration 36
OWM (set/display optional owner's message) 50
OWN (set/display optional owner's name) 50
PORT (display/set current data port) 50
PWR (set/display RF forward output power) 50
Radio transmitter test frequency (TX) 56
RSSI (display received signal strength) 51
RTU (enable/disable internal RTU) 52
RX (set/display receiver test frequency) 52
RXD 52
RXTOT (set/display received data timeout value) 52
SAF (store-and-forward) 53
SER (radio serial number) 53
SETUP (enter testing and setup mode) 53
SHOW (display measured power output) 54
SHOW PWR (show power) 54
SHOW SYNC 54
SHOW SYNC (show Clock-Synchronization Master) 54
SKIP (set/display frequency zone to skip) 54
SLEEP (display/set radio's sleep mode setting) 55
SLEEP (transceiver sleep mode) 55
SREV (firmware/software revision level) 55
STAT (list alarms) 55
TEMP (display internal temperature) 56
UNIT (unit address) 56
XADDR (extended address) 56

XMAP (Map of Extension Addresses) 56
XPRI (display/program primary radio's extended address) 57
XRSSI (sets minimum signal level for sync. with non-primary extension unit) 57

D

Data Baud Rate (BAUD) Command 42
Data Baud Rate (BUFF) Command 43
Data buffer setting 16, 43
DATA INTERFACE
cable wiring for tail-end links, illustrated 10
connector pin descriptions, table 79
Data interface
cable wiring for tail-end links, illustrated 20
Data Port Signalling Standard (PORT) Command 50
Default settings
data interface baud rate 17
factory settings reset by INIT command (table) 47
restoring (INIT command) 46
See also individual command descriptions
DEVICE Command 44
DEVICE command (set/display DCE or CTS Key behavior) 45
Diagnostics
network-wide, performing 62
setup mode (SETUP command) 53
using InSite software for network-wide 62
Diagnostics Link (DLINK) 45
Display
alarm output sense (ASENSE command) 42
alarms (STAT command) 55
CTS hold timer value (CTSHOLD command) 44
CTS line response timer value (CTS command) 44
data interface baud rate (BAUD command) 42
device behavior (DEVICE command) 45
hoptime setting (HOPTIME

- command) 46
- network address (ADDR command) 41
- operating status commands 37
- owner's message (OWM command) 50
- owner's name (OWN command) 50
- receive test frequency (RX command) 52
- received data handling mode (BUFF command) 43
- received data timeout value (RXTOT command) 52
- received signal strength (RSSI command) 51
- RF forward output power (PWR command) 50
- RF power output, actual measured (SHOW command) 54
- skipped frequency zones (SKIP command) 54
- temperature, internal (TEMP command) 56
- display/set radio mode as master, remote, or extension (see MODE command) 49
- DKEY command (disable transmitter) 16, 53
- DKEY, Disable Transmitter, Command 45
- DLINK command (set/display baud rate of diagnostics link) 62
- Downstream Repeat Transmission Count (REPEAT) Command 51
- DSP (digital signal processing) 59
- DTYPE command (set radio's diagnostics type) 46, 62
- E**
- Enable
 - internal RTU (RTU command) 52
 - network-wide diagnostics, procedures 62
 - Setup mode (SETUP command) 53
 - skipped zone (SKIP command) 54
 - Sleep Mode
- Enable/Disable LEDs (LED) Command 48
- Encryption. See CODE command
- Equipment List 45
- Evaluation Board
 - Description & connections to 74–80
 - PC Board Documentation 81–84
- Extended Address Command (XADDR) 56
- Extension radio. See Store-and-Forward (SAF)
- F**
- Feedline
 - selection 13, 14
- Firmware Revision Level Command (SREV) 55
- Forward-Error Correction (FEC) Command 46
- Full-Duplex Operation 31
- G**
- Gate (radio diagnostics type) 46
- H**
- Hardware Revision (HREV) Command 48
- Hayes-Compatible AT Command (AT) 42
- Hoptime
 - setting 16, 17
- HOPTIME Command (radio transmitter hop timing) 46
- HOPTIME command (set/display hoptime setting) 46
- I**
- Illustrations
 - antenna, Yagi 14
 - data interface cable wiring for tail-end links 10, 20
 - model configuration code 72, 80
 - point-to-point link 5
 - remote station arrangement 76
 - tail-end link 5
 - typical MAS network 4
- INIT command (restore factory default settings) 46
- Initialize 46
- InSite software 62
- Installation 11–15
 - connecting transceiver to data equipment 34
 - feedline selection 14



- performance optimization 15
- tail-end links 9, 20
- Interference
 - about 33
 - checks 17
 - troubleshooting 61
- interference 33
- K**
- Key
 - set to CTS keying (DEVICE command) 45
 - transmitter, for antenna SWR check 16
- KEY command (key transmitter) 16, 53
- L**
- LED status indicators
 - table 11, 60
- Low-Power Mode (LPM)
 - Command 48
- Low-Power Mode Sleep Time (LPMHOLD) Command 49
- LPM Command (low-power mode) 48
- LPMHOLD Command 49
- M**
- Map 56
- Map of Extension Addresses (XMAP) 56
- Master Station
 - default settings 47
- MIRRORED BITS™ Protocol
 - Support 30, 31
- MODE Command 49
- MODE command (display/set radio mode as master, remote, or extension) 49
- MODE command (display/set radio's operating mode as master, remote, or extension) 49
- Model configuration code,
 - illustrated 72, 80
- Modes
 - Low-Power Mode versus Remote's Sleep 30
- Mounting
 - instructions/dimensions 11–12
- Multiple Address System (MAS)
 - network, illustrated 4
- N**
- Network Address (ADDR)
 - Command 41
- Network configuration commands 36
- Network Diagnostics Mode (DTYPE)
 - Command 46
- Network-wide diagnostics
 - procedures 62
- Node (radio diagnostics type) 46
- O**
- LED 48
- Modbus, BUFF 43
- OWM command (set/display optional owner's message) 50
- OWN command (set/display optional owner's name) 50
- Owner's Message (OWM)
 - Command 50
- Owner's Name Command (OWN) 50
- P**
- PC
 - connecting to radio's diagnostic port 62
 - launching InSite application at 62
 - performing diagnostics using connected 62
- Peer (radio diagnostics type) 46
- Performance optimization 15
- Pins, DATA INTERFACE connector
 - descriptions (table) 79
- Point-to-point system
 - link, illustrated 5
- PORT command (set/display current data port) 50
- Power
 - Low-Power Mode versus Remote's Sleep 30
- Power (RF)
 - how much can be used 15
 - Measurement 54
 - set/display RF forward output (PWR command) 50
- Power saving mode (see Sleep Mode)
- Primary Extension Address (XPRI) 57
- Procedures
 - antenna aiming 16

- antenna and feedline selection 13
- antenna SWR check 16
- connecting data equipment to DATA INTERFACE connector 34
- connecting PC and radios for network-wide diagnostics 62
- enabling sleep mode
- installation 11–15
- interference check 17
- mounting the transceiver 11–12
- network-wide diagnostics 62
- performance optimization 15
- performing network-wide diagnostics 62
- programming radio for network-wide diagnostics 62
- troubleshooting 58–61
- Programming radio 41–57
 - as root or node 62
- PWR command (set/display RF forward output power) 50

R

Radio

- inoperative (troubleshooting chart) 61
- no synchronization with master (troubleshooting chart) 61
- poor performance (troubleshooting chart) 61
- Radio Operating Mode (MODE) Command 49, 50
- Radio Receive Test Frequency Command (RX) 52
- Radio Serial Number Command (SER) 53
- Radio Transmit Test Frequency (TX) 56
- Radio Transmitter Hop Timing (HOPTIME) 46
- Radio Transmitter Power Level (PWR) Command 50
- Radio's Internal Temperature Command (TEMP) 56
- Radio-MODEM Behavior (DEVICE) Command 45
- Receive Data Timeout-Timer Command (RXTOT) 52
- Received Signal Strength Indicator Command (RSSI) 51

- Remote radio
 - default settings 47
- Remote station
 - typical arrangement, illustrated 76
- Remote Terminal Unit Simulator Command (RTU) 52
- Repeater Operation. See Store-and-Forward (SAF)
- Restore to Factory Defaults (INIT) 46
- Root (radio diagnostics type) 46
- RSSI command (display received signal strength) 51
- RTU command (enable/disable internal RTU) 52
- RX command (set/display test receive frequency) 52
- RXD Command 52
- RXD Delay Command (RXD) 52
- RXTOT command (set/display received data timeout value) 52

S

- SAF command (store-and-forward) 53
- Seamless Mode Emulation 31
- Security Code (CODE) Command 43
- SER Command 53
- Set
 - alarm output sense (ASENSE command) 42
 - alarm output signal (AMASK command) 42
 - CTS hold timer (CTSHOLD command) 44
 - CTS line response timer (CTS command) 44
 - data interface baud rate (BAUD command) 42
 - DCE or CTS Key device behavior (DEVICE command) 45
 - frequency zone to skip (SKIP command) 54
 - hoptime (HOPTIME command) 46
 - network address (ADDR command) 41
 - owner's message (OWM command) 50
 - owner's name (OWN command) 50
 - radio mode (see MODE command) 49
 - received data handling mode (BUFF



- command) 43
- received data timeout value (RXTOT command) 52
- receiver test frequency (RX command) 52
- testing mode (SETUP command) 53
- SETUP command (enter testing and setup mode) 53
- Setup Radio Test (SETUP) 53
- Show Clock-Synchronization Master Network Address (SHOW SYNC) 54
- SHOW command (display power output) 54
- SHOW CON Command (show virtual connection status) 53
- Show Measured RF Transmit Power (SHOW PWR) 54
- SHOW SYNC Command 54
- Show Virtual Connection Status Command (SHOW CON) 53
- SKIP command (set/display frequency zone to skip) 54
- Skip Radio Operating Zones (SKIP) 54
- SLEEP command (display/set radio's sleep setting) 55
- SLEEP command (transceiver sleep ON/OFF) 55
- Sleep Mode 27
- Spread spectrum, basic principles of 4
- SREV Command 55
- STAT command (list alarms) 55
- Store-and-Forward (SAF) 6, 21, 25, 36, 40, 47, 53, 58
- Store-and-Forward Services (SAF) Support Command 53
- SWR (Standing Wave Ratio) performance optimization 16
- Synchronization qualifiers 19, 58

T

Tables

- accessories 6
- alarm codes 59
- antenna system gain vs. power output setting 18
- DATA INTERFACE connector pin descriptions 79
- LED status indicators 11, 60
- troubleshooting 61
- Tail-end link

- cable wiring for, illustrated 10, 20
- illustrated 5
- installation 9, 20
- Technical specifications 64–65
- TEMP command (display internal temperature) 56
- Temperature, display internal (TEMP command) 56
- Transceiver
 - connecting to data equipment 34
 - default settings 47
 - mounting
 - instructions/dimensions 11–12
 - performance optimization 15
 - sleep mode 27
- Transceiver Sleep (SLEEP) 55
- Troubleshooting 58–61
 - performing network-wide diagnostics 62
 - table 61
- Turn Off Radio Transmitter Test Signal (DKEY) Command 45
- Turn On Radio Transmitter Test Signal (KEY) Command 48

U

- UNIT Command (unit address) 56
- Upstream Repeat Transmission Count Command (RETRY) 51

X

- XADDR (extended address command) 8, 19, 20, 26, 40, 47, 58
- XADDR (extended address) Command 49
- XPRI command (display/set extended address) 57
- XRSSI command (sets minimum RSSI level to maintain sync. w/non-primary extension radio) 57

Z

- ZONE CLEAR (clear zone statistics log) 57
- ZONE DATA Command (read zone statistics log) 57
- Zone, Clear Statistics Log (ZONE CLEAR) 57
- Zone, Read Statistics Log (ZONE DATA) 57

IN CASE OF DIFFICULTY...

GE MDS products are designed for long life and trouble-free operation. However, this equipment, as with all electronic equipment, may have an occasional component failure. The following information will assist you in the event that servicing becomes necessary.

CUSTOMER ASSISTANCE

Assistance for GE MDS products is available from our Customer Support Team during business hours (8:00 A.M.–5:30 P.M. Eastern Time). When calling, please give the complete model number of the equipment, along with a description of the trouble/symptom(s) that you are experiencing. In many cases, problems can be resolved over the telephone, without the need for returning the unit to the factory. Please use one of the following means for product assistance:

Phone: 585 241-5510
FAX: 585 242-8369

E-Mail: techsupport@microwavedata.com
Web: www.GEmds.com

FACTORY SERVICE

Component level repair of this equipment is not recommended in the field. Many components are installed using surface mount technology, which requires specialized training and equipment for proper servicing. For this reason, the equipment should be returned to the factory for any PC board repairs. The factory is best equipped to diagnose, repair and align your radio to its proper operating specifications.

If return of the equipment is necessary, you must obtain a Service Request Order (SRO) number. This number helps expedite the repair so that the equipment can be repaired and returned to you as quickly as possible. Please be sure to include the SRO number on the outside of the shipping box, and on any correspondence relating to the repair. No equipment will be accepted for repair without an SRO number.

SRO numbers are issued online at www.GEmds.com/support/product/sro/. Your number will be issued immediately after the required information is entered. Please be sure to have the model number(s), serial number(s), detailed reason for return, “ship to” address, “bill to” address, and contact name, phone number, and fax number available when requesting an SRO number. A purchase order number or pre-payment will be required for any units that are out of warranty, or for product conversion.

If you prefer, you may contact our Product Services department to obtain an SRO number:

Phone Number: 585-241-5540
Fax Number: 585-242-8400
E-mail Address: ProductServicesRochester@ge.com

The radio must be properly packed for return to the factory. The original shipping container and packaging materials should be used whenever possible. All factory returns should be addressed to:

GE MDS, LLC
Product Services Department
(SRO No. XXXX)
175 Science Parkway
Rochester, NY 14620 USA

When repairs have been completed, the equipment will be returned to you by the same shipping method used to send it to the factory. Please specify if you wish to make different shipping arrangements. To inquire about an in-process repair, you may contact our Product Services Group using the telephone, Fax, or E-mail information given above.



GE MDS
industrial wireless networks

GE MDS, LLC
175 Science Parkway
Rochester, NY 14620
General Business: +1 585 242-9600
FAX: +1 585 242-9620
Web: www.GEmds.com

