

Microwave Data Systems Inc.  
**MDS TransNET OEM™**

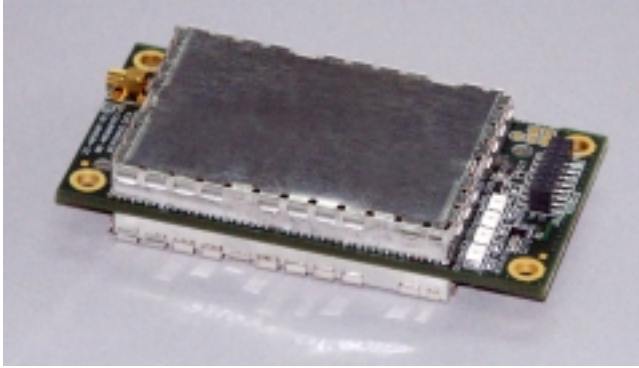

Transceiver Model EL806

## **Spread Spectrum Data Transceiver**

*Including Instructions for  
03-4053A01 Evaluation Development Kit*

MDS 05-3946A01, Rev. A  
APRIL 2003

**industrial/wireless/performance**



---

# QUICK START GUIDE

---

The steps below contain the essential information needed to place the OEM transceiver in service. Because the transceiver is designed for use in other pieces of equipment, these steps assume that prior testing and evaluation have been conducted with the host device. If not, please refer to Section 3.0, Benchtop Setup and Evaluation for proper interface wiring and configuration.

## 1. Mount the transceiver module using the four holes provided.

---

- If possible, select a mounting location that allows viewing the status LEDs and provides ready access to the antenna connector.
- Use standoff hardware to secure the board to the host device.
- When mounting the board, use care to align the transceiver's 16-pin header connector with the mating pins in the host device.

## 2. Connect the antenna system to the transceiver

---

- Use only with antenna/feedline assemblies that have been expressly tested and approved for such service by Microwave Data Systems Inc.
- Use an MMCX-type male connector to attach the antenna to the transceiver.
- For best performance, antennas should be mounted in the clear, with an unobstructed path in the direction of desired transmission/reception.





## 3. Apply power and observe the LEDs for proper operation. The LED command must be set to ON (LEDS ON).

---

After 16 seconds...

- The GP lamp should be lit continuously
- The DCD lamp should be lit continuously—if synchronization with another unit has been achieved
- The Remote radio(s) should be transmitting data (TXD) and receiving data (RXD) with its associated station

### LED Indicator Descriptions

LED Name	Description	
RXD (CR3) Receive Data	Serial receive data activity. Payload data from connected device.	
TXD (CR4) Transmit Data	Serial transmit data activity. Payload data to connected device.	RXD 
DCD (CR5) Data Carrier Detect	Continuous—Radio is receiving/sending synchronization frames On within 10 seconds of power-up under normal conditions	TXD  DCD 
GP (CR6) General Purpose	<ul style="list-style-type: none"><li>• Continuous—Power is applied to the radio; no problems detected</li><li>• Flashing (5 times-per-second)—Fault indication. See "TROUBLESHOOTING" on Page 52</li><li>• Off—Radio is unpowered or in Sleep mode</li></ul>	GP 



---

# CONTENTS

---

1.0 ABOUT THIS MANUAL.....	1
<hr/>	
2.0 PRODUCT DESCRIPTION.....	1
<hr/>	
2.1 Transceiver Features .....	2
2.2 Model Configuration Codes .....	2
2.3 Spread Spectrum Transmission .....	3
2.4 Typical Applications .....	3
Multiple Address Systems (MAS) .....	3
Point-to-Point System .....	4
Tail-End Link to an Existing Network .....	5
Store-and-Forward Repeater .....	5
2.5 Transceiver Accessories .....	6
3.0 BENCHTOP SETUP & EVALUATION.....	7
<hr/>	
3.1 Evaluation Development Kit (P/N 03-4053A01) .....	7
Evaluation Board .....	8
Connecting the Eval. Board & Transceiver (Figure 8) .....	9
3.2 Cable Connections for Benchtop Testing .....	10
Antenna Connection (J200 on the transceiver module)...	10
Diagnostic Connection (J4).....	11
Data Connector (J5) .....	12
DC Power Connector (J3).....	14
Jumper Block J1 (DC Power Configuration) .....	15
3.3 Initial Power-Up & Configuration .....	15
Configuration Settings .....	16
LED Indicators .....	17
4.0 EVALUATION BOARD DOCUMENTATION .....	18
<hr/>	
4.1 Assembly Drawing .....	18
4.2 Parts List .....	18
4.3 Evaluation Board Fuse Replacement .....	20
5.0 TRANSCEIVER MOUNTING.....	21
<hr/>	



- 5.1 Mounting Dimensions ..... 21
- 5.2 Antennas & Feedlines ..... 21
  - Feedlines..... 22
- 6.0 OPTIMIZING PERFORMANCE..... 23

---

- 6.1 Antenna Aiming ..... 23
- 6.2 Antenna SWR Check ..... 23
- 6.3 Data Buffer Setting ..... 23
- 6.4 Hoptime Setting ..... 23
- 6.5 Operation at 115200 bps ..... 24
- 6.6 Baud Rate Setting ..... 24
- 6.7 Radio Interference Checks ..... 24
- 6.8 RF Output Setting ..... 24
- 7.0 OPERATING PRINCIPLES & SPECIAL CONFIGURATIONS ..... 25

---

- 7.1 How Remotes Acquire Synchronization ..... 25
- 7.2 Establishing a Tail-End Link ..... 25
- 7.3 Store & Forward (SAF) Operation with Extension Radios 26
  - Simple Extended SAF Network..... 26
  - Extended SAF Network..... 27
  - Retransmission and ARQ operation..... 28
  - Synchronization in SAF Networks..... 28
  - Configuration Parameters for Store-and Forward Services29
- 7.4 Sleep Mode Operation (Remote units only) ..... 31
  - Sleep Mode Example ..... 32
- 8.0 DEALING WITH INTERFERENCE..... 32

---

- 9.0 PROGRAMMING REFERENCE ..... 34

---

- 9.1 Programming Methods ..... 34
  - Terminal Interface Mode..... 34
  - PC-Based Configuration Software ..... 34
- 9.2 User Commands ..... 34
  - Entering Commands ..... 35
- 9.3 Detailed Command Descriptions ..... 40
  - ADDR [1–65000] ..... 40
  - AMASK [0000 0000–FFFF FFFF] ..... 41



ASENSE [HI/LO].....	41
BAUD [xxxxx abc].....	41
BUFF [ON, OFF].....	41
CODE [NONE, 1...255] .....	42
CTS [0-255].....	42
CTSHOLD [0-60000].....	43
DEVICE [DCE, CTS KEY] .....	43
DLINK [xxxxx/ON/OFF].....	43
DKEY .....	44
DTYPE [NODE/ROOT] .....	44
FEC [ON, OFF] .....	44
HOPTIME [7, 28] .....	44
INIT .....	44
HREV .....	45
KEY.....	45
LEDS [ON, OFF].....	45
MODE [M, R, X] .....	45
OWM [xxxxx].....	45
OWN [xxxxx] .....	45
PORT [RS232, RS485].....	45
PWR [20-30] .....	46
REPEAT [0-10].....	47
RETRY [0-10].....	47
RSSI .....	47
RTU [ON, OFF, 0-80] .....	48
RX [xxxx].....	48
RXTOT [NONE, 0-1440] .....	48
SAF [ON, OFF] .....	48
SETUP .....	48
SER .....	49
SHOW PWR .....	49
SHOW SYNC.....	49
SKIP [NONE, 1...8] .....	49
SLEEP [ON, OFF].....	50
SREV .....	50
STAT .....	50
TEMP.....	50
TX [xxxx].....	50
UNIT [10000-65000] .....	50



XADDR [0–31].....	51
XMAP [00000000-FFFFFFFF] .....	51
XPRI [0–31].....	51
XRSSI [NONE, –40...–120] .....	51
ZONE CLEAR .....	51
ZONE DATA.....	51
<b>10.0 TROUBLESHOOTING.....</b>	<b>52</b>
<hr/>	
10.1 Alarm Codes .....	53
Checking for Alarms—STAT command .....	53
Major Alarms vs. Minor Alarms .....	53
Alarm Code Definitions .....	53
10.2 LED Indicators .....	54
10.3 Troubleshooting Chart .....	54
10.4 Network-Wide Remote Diagnostics .....	55
<b>11.0 FIRMWARE UPGRADES.....</b>	<b>57</b>
<hr/>	
11.1 Obtaining new firmware .....	57
Saving a Web-site firmware file to your PC .....	57
11.2 Installing firmware in your radio .....	57
<b>12.0 Security .....</b>	<b>57</b>
<hr/>	
<b>13.0 Product Specifications.....</b>	<b>58</b>
<hr/>	
13.1 Detailed Pin Descriptions .....	59
<b>14.0 dBm-Watts-Volts Conversion Chart.....</b>	<b>66</b>
<hr/>	

**To Our Customers**

We appreciate your patronage. You are our business. We promise to serve and anticipate your needs. We strive to give you solutions that are cost effective, innovative, reliable and of the highest quality possible. We promise to build a relationship that is forthright and ethical, one that builds confidence and trust.

**Copyright Notice**

This Installation and Operation Guide and all software described herein are Copyright 2003 by Microwave Data Systems Inc. All rights reserved. Microwave Data Systems Inc. reserves its right to correct any errors and omissions in this manual.



## RF Exposure Notice

**RF EXPOSURE**  The radio equipment described in this guide emits radio frequency energy. Although the power level is low, the concentrated energy from a directional antenna may pose a health hazard. **All antenna(s) used with this transmitter, whether indoor or outdoor mounted, must be installed to provide a separation distance of at least 23 cm (9 inches) from all persons, and must not be co-located or operating in conjunction with any other antenna or transmitter.**

In mobile applications (vehicle mounted) the above separation distance must be maintained at all times. More information on RF exposure is available on the Internet at [www.fcc.gov/oet/info/documents/bulletins](http://www.fcc.gov/oet/info/documents/bulletins).

## FCC Part 15 Notice

This equipment has been tested and found to comply with the limits for a Class A digital device, pursuant to part 15 of the FCC Rules. These limits are designed to provide reasonable protection against harmful interference when the equipment is operated in a commercial environment. This equipment generates, uses, and can radiate radio frequency energy and, if not installed and used in accordance with the instruction manual, may cause harmful interference to radio communications. Operation of this equipment in a residential area is likely to cause harmful interference in which case the user will be required to correct the interference at his own expense.

## FCC Modular Approval Notice

This device is offered as an FCC Part 15 Unlicensed Modular Transmitter. This Modular Transmitter is approved for use only with specific antenna, cable and output power configurations that have been tested and approved by the manufacturer (Microwave Data Systems Inc.). Modifications to the radio, the antenna system, or power output, that have not been explicitly specified by the manufacturer are not permitted, and may render the radio non-compliant with applicable regulatory authorities. Refer to [Table 7 on Page 24](#) for more detailed information.

This device employs a unique connector at all connections between the module and the antenna, including the cable. Consult MDS for approved antenna/cable assemblies in our product offering. When this device is placed inside an enclosure, a durable label must be affixed to the outside of that enclosure which includes this module's FCC ID Number.

**Changes or modifications not expressly approved by the party responsible for compliance could void the user's authority to operate the equipment.**

## ISO 9001 Registration

Microwave Data Systems adheres to the internationally-accepted ISO 9001 quality system standard.

## Manual Revision and Accuracy

While every reasonable effort has been made to ensure the accuracy of this manual, product improvements may result in minor differences between the manual and the product shipped to you. If you have additional questions or need an exact specification for a product, please contact our Customer Service Team using the information at the back of this guide. In addition, manual updates can often be found on the MDS Web site at [www.microwavedata.com](http://www.microwavedata.com).







## 1.0 ABOUT THIS MANUAL

This manual is intended to guide technical personnel in the integration of MDS TransNET OEM™ transceivers into existing electronic equipment. The OEM transceiver is designed for use inside Remote Terminal Units (RTUs), Programmable Logic Controllers (PLCs) and other equipment associated with remote data collection, telemetry and control.

The manual provides instructions for interface connections, hardware mounting, and programming commands. Following integration of the transceiver, it is recommended that a copy of this manual be retained for future reference by technical personnel.

## 2.0 PRODUCT DESCRIPTION

The OEM transceiver, (Figure 1), is a compact, spread spectrum wireless module designed for license-free operation in the 902-928 MHz frequency range. It is contained on one double-sided circuit board with all necessary components and RF shielding included. It need only be protected from direct exposure to the weather and is designed for rugged service in extreme temperature environments. The transceiver has full over-the-air compatibility with standard (non-OEM) TransNET 900™ transceivers manufactured by MDS.

All transceiver programming is performed via a connected PC terminal. No jumper settings or manual adjustments are used to configure the transceiver for operation.

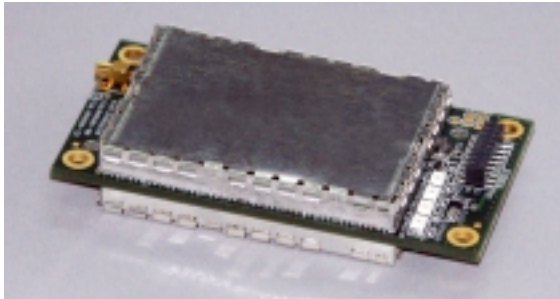

**Figure 1. TransNET OEM™ Transceiver**

The transceiver employs Digital Signal Processing (DSP) technology for highly reliable data communications, even in the presence of weak or interfering signals. DSP techniques also make it possible to obtain information about the radio's operation and troubleshoot problems, often eliminating the need for site visits.

Using appropriate software at the master station, diagnostic data can be retrieved for any radio in the system, even while payload data is being transmitted. (See "Network-Wide Remote Diagnostics" on Page 55.)



## 2.1 Transceiver Features

The OEM transceiver is designed for easy installation and flexibility in a wide range of wireless applications. Listed below are several key features of the transceiver which are described in more detail later in this guide.

- 128 frequencies over 902–928 MHz, subdivided into eight frequency zones
- Configurable operating zones to omit frequencies with constant interference
- 65,000 available network addresses to enhance communications security
- Network-wide configuration from the master station; eliminates most trips to remote sites
- Data transparency—ensures compatibility with virtually all asynchronous data terminals
- Peak-hold RSSI, averaged over eight hop cycles
- Operation at up to 115,200 bps continuous data flow
- Store-and-Forward repeater operation
- Data latency typically less than 10 ms
- Same hardware for master or remote configuration
- Supports RS/EIA-232 or RS/EIA-485 interfaces (factory configured)
- Low current consumption—nominal 8 mA in “sleep” mode. Ideal for solar/battery powered applications.

**NOTE:** Some features may not be available on all units, based on the options purchased and the regulatory constraints for the region in which the radio will operate.

## 2.2 Model Configuration Codes

The model number code is printed on the radio module, and provides key information about how it was configured when it left the factory. See [Figure 2](#) for an explanation of the model number codes. (Note: This information is subject to change and should not be used for ordering additional products. Your factory representative can assist you with product ordering.)

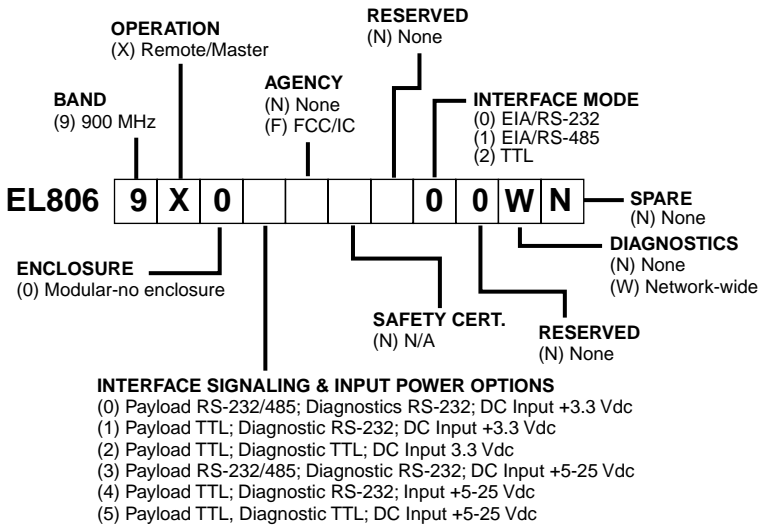

Figure 2. Model Number Configuration Codes

## 2.3 Spread Spectrum Transmission

The transceiver “hops” from channel to channel many times per second using a specific hop pattern applied to all radios in the network. A distinct hopping pattern is provided for each of the 65,000 available network addresses, thereby minimizing the chance of interference with other spread spectrum systems.

In the USA, and certain other countries, no license is required to install and operate this type of radio device, provided RF power and antenna gain restrictions are observed. In the USA and Canada, a maximum of 36 dBm Effective Isotropic Radiated Power (EIRP) is allowed. The factory offers a set of approved antennas with special connectors for this radio. Substitutions that would void the compliance of the device are not permitted.

## 2.4 Typical Applications

### Multiple Address Systems (MAS)

This is the most common application of the transceiver. It consists of a central control station (master) and two or more associated remote units, as shown in Figure 3. This type of network provides communications between a central host computer and remote terminal units (RTUs) or other data collection devices. The operation of the radio system is transparent to the computer equipment. This application provides a practical alternative to traditional (licensed) MAS radio systems.

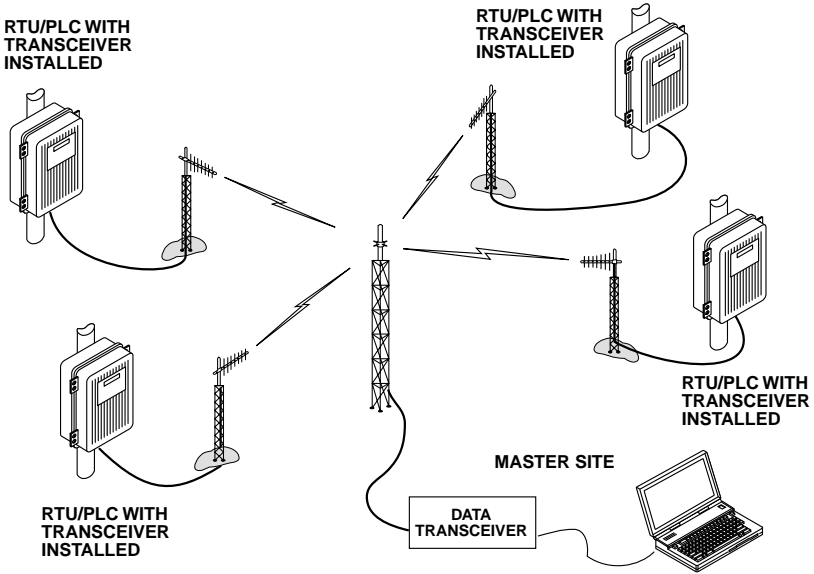

Figure 3. Typical MAS Network

### Point-to-Point System

A point-to-point configuration (Figure 4) is a simple arrangement consisting of just two radios—a master and a remote. This provides a half-duplex communications link for the transfer of data between two locations.

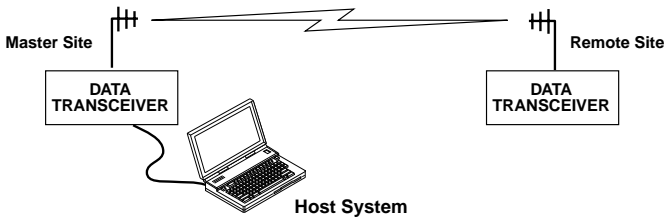

Figure 4. Typical Point-to-Point Link



## Tail-End Link to an Existing Network

A tail-end link is often used to extend the range of a traditional (licensed) MAS system without adding another licensed radio. This might be required if an outlying site is blocked from the MAS master station by a natural or man-made obstruction. In this arrangement, a spread spectrum transceiver links the outlying remote site into the rest of the system by sending data from that site to an associated transceiver installed at one of the licensed remote sites—usually the one closest to the outlying facility. (See [Figure 5](#)).

As the data from the outlying site is received at the associated transceiver, it is transferred to the co-located licensed radio (via a data crossover cable) and is transmitted to the MAS master station over the licensed channel. Additional details for tail-end links are given in [Section 7.2 \(Page 25\)](#).

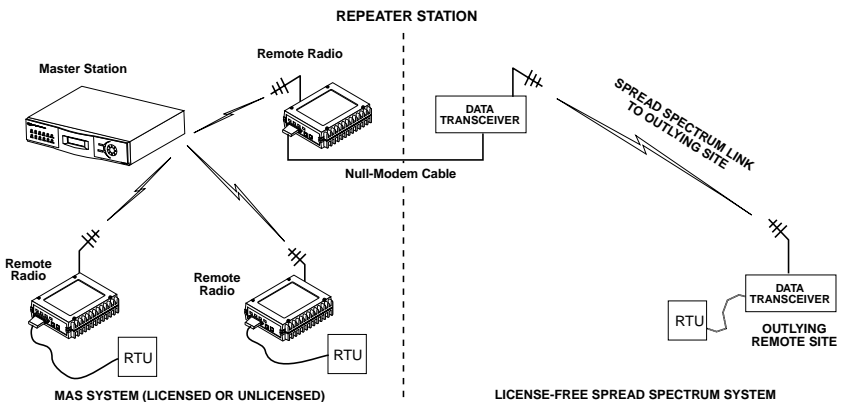

**Figure 5. Typical Tail-End Link Arrangement**

## Store-and-Forward Repeater

Similar to a Tail-End Link, Store-and-Forward (SAF) offers a way to physically extend the range of a network, but in a simplified and economical manner. SAF operates by storing up the data received from one site, and then retransmitting it a short time later. [Figure 6](#) shows a typical SAF repeater arrangement.

SAF operates by dividing a network into a vertical hierarchy of two or more sub-networks. Extension radios (designated as **MODE X**) serve as single-radio repeaters that link adjacent sub-networks, and move data from one sub-network to the next. Additional information on SAF mode is provided in [“Store & Forward \(SAF\) Operation with Extension Radios”](#) on [Page 26](#).

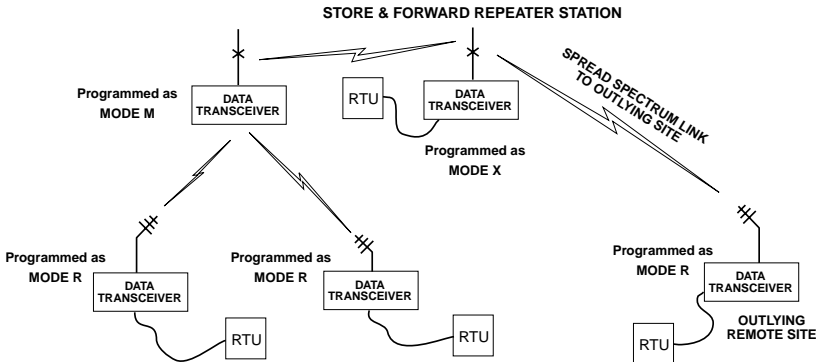

Figure 6. Store-and-Forward Repeater Network

## 2.5 Transceiver Accessories

One or more of the accessories listed in [Table 1](#) may be used with the OEM transceiver. Contact your factory representative for availability and ordering details.

Table 1. OEM Transceiver Accessories

Accessory	Description	Part No.
AC Power Adapter	Small power supply designed for continuous operation of the transceiver. UL approved. Input: 120/220; Output: 12 Vdc.	01-3862A02
TransNET Support Package CD	Programming, diagnostic and support files on a CD ROM. Includes electronic copy of this guide (PDF format).	03-2708A01
TNC Male-to-N Male Coax Cable Assy.	3 ft/1 meter shielded antenna cable	97-1677A159
TNC Male-to-N Male Coax Cable Assy.	6 ft/1.8 meter shielded antenna cable	97-1677A160
TNC male-to-N Female Adapter	One-piece RF adaptor plug	97-1677A161
RJ-11-to-DB9 Adapter Cable	Short cable assembly that converts RJ-11 to DB9 connector type	03-3246A01
Fuse (for Evaluation Board)	2A SMF Slo-Blo (plugs into FH1 on Evaluation Board)	29-1784A03
InSite Diagnostic Software	PC-based diagnostic software for MDS radios. Supplied on CD.	03-3533A01
Omnidirectional Antennas	Rugged antennas suitable for use at Master stations.	Various

**Table 1. OEM Transceiver Accessories (Continued)**

Yagi Antenna	Rugged directional antennas suitable for use at Remote stations.	Various
Whip Antennas	Short, flexible antennas suitable for short-range applications. Available with and without coaxial feedlines.	Various
Bandpass Filter	Antenna system filter to aid in eliminating interference from high power transmitters, such as those used in paging systems.	20-2822A01
Evaluation Development Kit	Kit containing two OEM Transceiver modules, whip antennas, two Evaluation Boards, support software on CD, cables, power supplies and other accessories needed to operate the transceiver in a benchtop setting.	32-4051A01

### 3.0 BENCHTOP SETUP & EVALUATION

As an Integrator, your first task is to verify that the OEM module will function as intended with the host equipment. This section describes how to test the unit for operation with host devices such as RTUs, PLCs and similar gear. It covers the steps for making interface connections, powering up the transceiver, and setting configuration parameters using a connected PC.

Evaluation of the module is best performed in a controlled environment, such as a shop or lab facility where you can readily test various hardware and programming configurations and observe the effects of these changes before final installation.

Once you are satisfied that the transceiver module operates properly on the bench, you can plan the installation of the module inside the host device and be assured of proper operation in the field.

#### 3.1 Evaluation Development Kit (P/N 03-4053A01)

The Evaluation Development Kit is designed to assist integrators who will be working with the transceiver in a benchtop setting. The kit contains the following:

- Two OEM Transceiver modules (configured for TTL, or RS-232/485 operation, as requested)
- Two Evaluation Development boards (P/N 03-4051A01)
- Interface Cables
- Two whip antennas
- Two 12 Vdc power supplies
- TransNET Support CD containing software for programming & diagnostics



## Evaluation Board

A key part of the Evaluation Development Kit is the Evaluation Board shown in Figure 7. It contains a 16-pin header connector (J2) that mates with female connector J3 the OEM transceiver board. It carries all signals (except RF) onto the Evaluation Board. Table 2 lists the basic pin functions of J2. For more detailed pinout information, including the differences between TTL and RS-232/485 configured radios, refer to Section 13.1 on Page 59.

The Evaluation Board provides convenient connection points for diagnostics, payload data, and DC power. Each of these connectors are discussed in this section. The board also includes a series of test probe points to the left of J2. These may be used for monitoring logic signal activity with a multimeter or oscilloscope. The probe points are identified by printed markings on the board.

The transceiver board’s RF/Antenna connection is *not* brought onto the Evaluation Board by the 16-pin header. The antenna connection is always made at J200 on the transceiver module using a male MMCX-type connector.

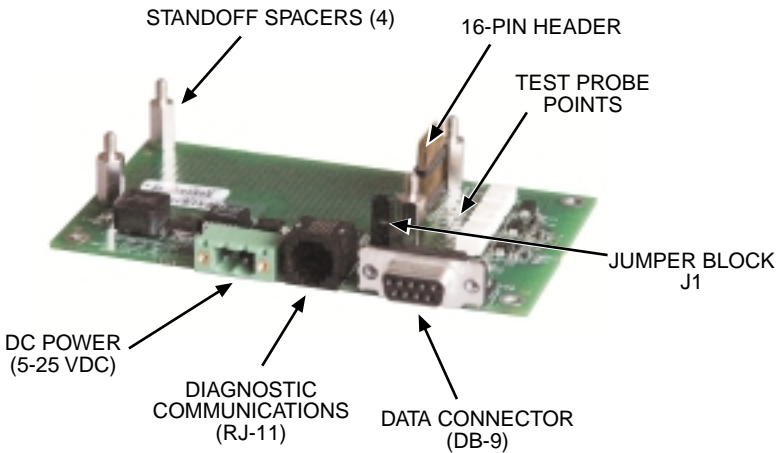

Figure 7. OEM Evaluation Board (P/N 03-4051A01)

Table 2. Basic Pin Functions of J2 (16-Pin Header Connector)

Pin No.	Pin Function
1	Ground
2	Diagnostic TXD
3	Alarm Condition
4	Diagnostic RXD



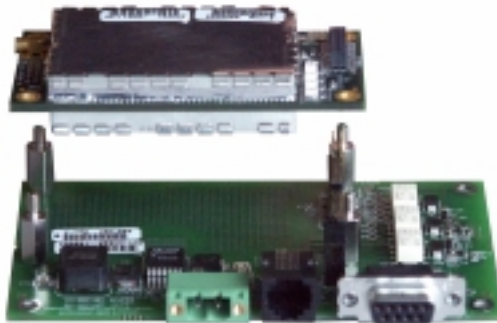

**Table 2. Basic Pin Functions of J2 (16-Pin Header Connector)**

5	DC Input
6	Sleep Mode Input
7	Data Carrier Detect (DCD)
8	Power Supply Shutdown Control
9	Reserved—Do not connect.
10	Transmitted Payload Data (TXD)
11	DC Input
12	Request to Send (RTS)
13	Reserved—Do not connect.
14	Received Payload Data (RXD)
15	Ground
16	Clear to Send (CTS)

### Connecting the Evaluation Board & Transceiver (Figure 8)

To connect the Evaluation Board to the radio, carefully align the pins of the 16-pin header with J3 on the transceiver module and press down firmly. The radio PC board should seat solidly on the four standoff spacers. Use nuts to secure the board to the standoffs.



**Figure 8. Connecting the Evaluation Board and Transceiver Together**

**CAUTION:** Take care to avoid short-circuiting the underside of the Evaluation PC board. The bottom of the board is *not* insulated, and contact with metallic objects on the work surface could cause damage to the board or connected equipment.



## 3.2 Cable Connections for Benchtop Testing

There are four basic requirements for operating the transceiver and evaluation board in a benchtop test environment. They are:

- Adequate and stable primary power
- A proper antenna system or RF load (50 Ohms)
- The correct interface wiring between the transceiver and the connected DTE device (RTU, PLC, etc.)
- A connected PC terminal to read/set transceiver parameters.

Figure 9 shows a typical setup for bench testing an OEM Transceiver. Two such setups will be required if you intend to establish over-the-air communications with another OEM transceiver.

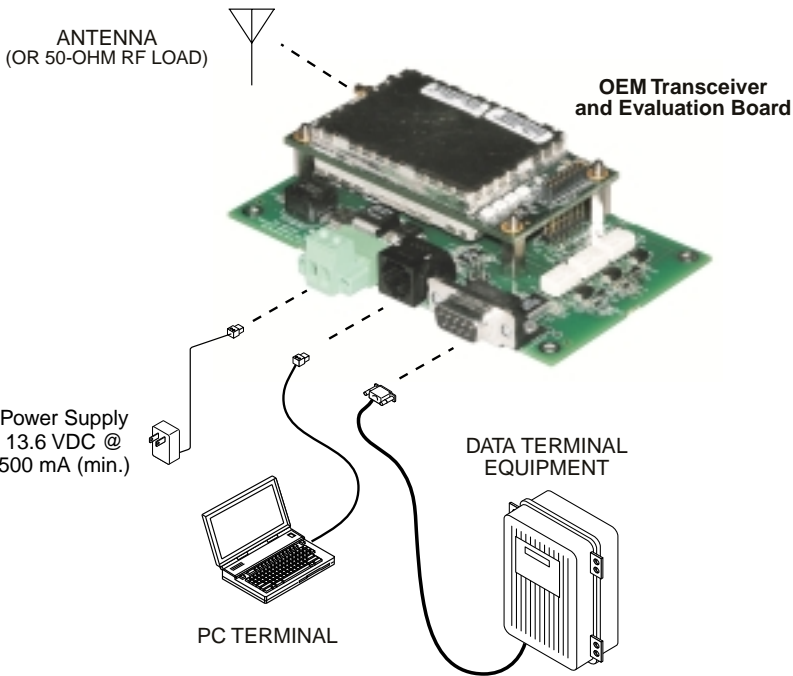

**Figure 9. Typical Test Setup**

### Antenna Connection (J200 on the transceiver module)

The Antenna connector is located at the upper left corner of the transceiver module and is a female MMCX-type coaxial connector. Connect an antenna or other suitable RF load to this connector. Only approved antenna/cable assemblies may be used with the radio

**CAUTION**  
POSSIBLE  
EQUIPMENT  
DAMAGE

Do not apply DC power to the transceiver without first attaching a proper RF load, or the transceiver may be damaged.

## Diagnostic Connection (J4)

J4 is an RJ-11-6 modular connector used to connect the evaluation board/transceiver to a PC terminal for programming and interrogation. An RJ-11 to DB-9 Adapter Cable (Part No. 03-3246A01) is required for this connection. If desired, a cable may be constructed for this purpose as shown in [Figure 10](#). Only Pins 4, 5, and 6 of the RJ-11 connector should be used. Pins 1, 2, and 3 are reserved for factory test purposes.)

The data parameters of the diagnostics port are as follows: 8 data bits, 1 stop bit, and no parity. It automatically configures itself to function at 1200, 2400, 4800, 9600, 19200, 38400, 57600, and 115200 bps, as required.

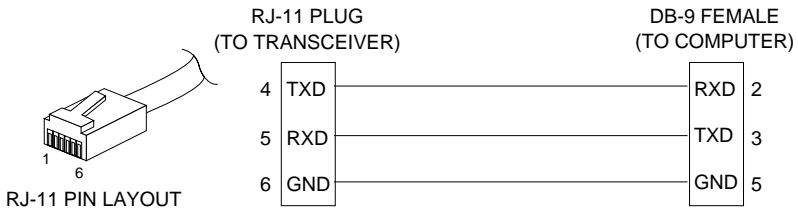

**Figure 10. RJ-11 to DB-9 Diagnostic Cable—Wiring Details**  
(A pre-constructed cable is also available, Part No. 03-3246A01)

## Diagnostic Communication Modes

Two methods may be used to communicate with the radio's diagnostic port:

- **Terminal Interface**—The PC is used in its basic terminal emulation mode, (i.e., HyperTerminal session) and commands are issued as simple text strings.
- **Radio Configuration Software**—Proprietary software from MDS that runs under the Windows operating system. It provides a graphical user interface with “point and click” functionality. The program is included on the *TransNET Support Package* CD shipped with every radio order.

Both of these control methods are described in more detail in the section titled “**PROGRAMMING REFERENCE**” on [Page 34](#). This section also includes a chart listing all commands for the OEM transceiver.



## Data Connector (J5)

J5 on the Evaluation Board (Figure 11) is the data interface for the transceiver. It is used to connect the transceiver to an external DTE terminal that supports the EIA/RS-232 or EIA/RS-485 format, depending on how the radio hardware was configured at the factory. The data connector supports interface data rates of 1200, 2400, 4800, 9600, 19200, 38400, 57600, and 115200 bps (asynchronous only). The connector mates with a standard DB-9 plug available from many electronics parts suppliers.

### Data Wiring Connections

The connections made to J5 will depend on the requirements of the DTE device being used with the transceiver, and the operating functions that you require. Only the required pins for the application should be used. Do not use a straight through “computer” type cable that is wired pin-for-pin.

Typical RS/EIA-232 applications require the use of Pin 2 (receive data—RXD) and Pin 3 (transmit data—TXD). Additionally, some systems may require the use of Pin 7 (Request-to-send—RTS). If hardware flow control is desired, Pin 7 (RTS) and Pin 8 (CTS) may also need connection.

Table 3 gives pin details for radios configured for RS/EIA-232 service.

Table 4 gives details for radios configured for RS/EIA-485 service.

**NOTE:** Radios equipped with a payload TTL interface are presented as RS-232 mode from the Evaluation Board.

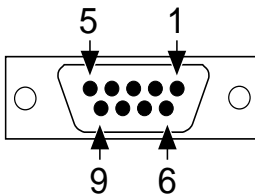

**Figure 11. DATA Connector (DB-9F)**  
As viewed from outside the device



### Pin Descriptions—RS/EIA-232 Mode

Table 3 lists the DATA connector pin functions for radios configured to operate in RS/EIA-232 mode.

**Table 3. J5 DATA Connector Pinouts—RS/EIA-232**

Pin Number	Input/Output	Pin Description
1	OUT	<b>Data Carrier Detect (DCD)</b> —A low indicates hopping synchronization has been achieved.
2	OUT	<b>Received Data (RXD)</b> —Supplies received payload data to the connected device.
3	IN	<b>Transmitted Data (TXD)</b> —Accepts payload data from the connected device.
4	IN	<b>Sleep Mode Input</b> —A ground on this pin turns off most circuits in a remote radio. This allows for greatly reduced power consumption, yet preserves the radio's ability to be brought quickly back on line. See "Sleep Mode Operation (Remote units only)" on Page 31 for details.
5	IN	<b>Ground</b> —Connects to ground (negative supply potential).
6	OUT	<b>Alarm condition</b> —A low indicates normal operation. A high indicates an alarm. (See ASENSE [HI/LO] command for more information.)
7	IN	<b>Request to Send (RTS)</b> —A high causes CTS to follow after the programmed CTS delay time has elapsed (DCE).
8	OUT	<b>Clear to Send (CTS)</b> —Goes high after the programmed CTS delay time has elapsed (DCE), or keys an attached radio when RF data arrives (CTS KEY).
9	--	Reserved—Do not connect.

### Pin Descriptions—RS/EIA-422/485 Mode

Table 4 on the following page lists the DATA connector pin functions for radios configured to operate in RS/EIA-422/485 mode. See Figure 12 for wiring schemes.

**NOTE:** Radios equipped with a payload RS-232/485 interface can select **PORT RS485** for RS/EIA-485 mode.

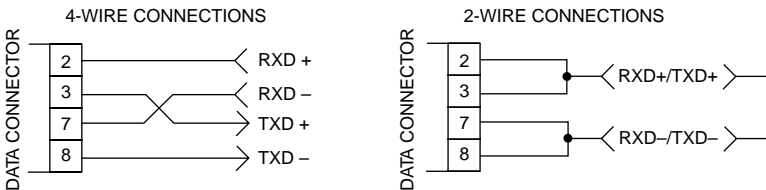

**Table 4. DATA connector pin descriptions—RS/EIA-485 Mode**

Pin Number	Input/Output	Pin Description
1	—	Reserved—Do not connect.
2	OUT	<b>TXD+/TXA (Received Data +)</b> —Non-inverting driver output.
3	IN	<b>RXD+/RXA (Transmitted Data +)</b> —Non-inverting receiver input.
4	IN	<b>Sleep Mode Input</b> —A ground on this pin turns off most circuits in a remote radio. This allows for greatly reduced power consumption, yet preserves the radio’s ability to be brought quickly back on line. See “ <b>Sleep Mode Operation (Remote units only)</b> ” on Page 31 for details.
5	IN	<b>Ground</b> —Connects to ground (negative supply potential).
6	--	Reserved—Do not connect.
7	IN	<b>RXD-/RXB (Transmitted Data -)</b> —Inverting receiver input.
8	OUT	<b>TXD-/TXB (Received Data -)</b> —Inverting driver output.
9	--	Reserved—Do not connect.

**Table 4 Notes:**

- RXD+/RXA and RXD-/RXB are data sent into the radio to be transmitted out
- RXD+/RXA is positive with respect to RXD-/RXB when the line input is a “0”
- TXD+/TXA and TXD-/TXB are data received by the radio and sent to the connected device
- TXD+/TXA is positive with respect to TXD-/TXB when the line output is a “0”



**Figure 12. EIA-422/485 Wiring Schemes (Left: EIA-422, Right: EIA-485)**

**DC Power Connector (J3)**

This connector accepts 12 Vdc operating power for the transceiver. A wall-style AC adapter (Part No. 01-3862A02) is recommended for this service.

DC connection is made with a 2-pin polarized plug, MDS Part No. 73-1194A39. Be sure to observe proper polarity. **The left terminal is positive (+) and the right is negative (-).** (See Figure 13).

**CAUTION**

POSSIBLE  
EQUIPMENT  
DAMAGE

The transceiver must be used only with negative-ground systems. Make certain that the polarity of the power source is correct.

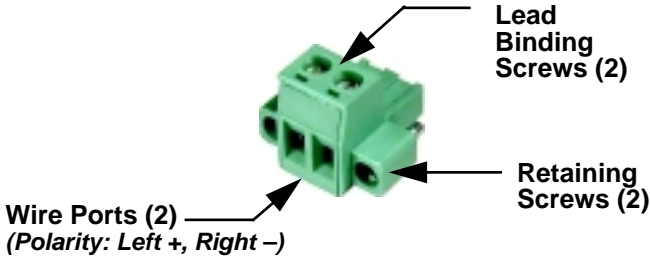

**Figure 13. DC Power Connector (P/N 73-1194A39)**

**NOTE:** Although the power connector used on the OEM Evaluation Board resembles those used by some earlier MDS transceivers, such as the MDS 9810 and x710 family, the connectors are *not* equal and the use of the wrong plug will provide unreliable connections. Only the power connector shown in [Figure 13](#) with screw terminals and two retainer screws should be used with the OEM Evaluation Board.

### Jumper Block J1 (DC Power Configuration)

*Jumper J1 does not normally require any change by the user.* The jumper is used to configure the board for the proper voltage level applied to the transceiver module.

*Both* jumper plugs are normally installed on J1. The plug connecting Pins 3 and 4 may be temporarily removed to insert an ammeter in series with the DC power line going to the transceiver. This provides a convenient way to measure the transceiver's current draw during bench testing.

## 3.3 Initial Power-Up & Configuration

When all of the cable connections described in Section 3.2 have been made, the transceiver is ready for initial power-up. Operation begins as soon as power is applied, and there are no manual adjustments or settings required.

To place the transceiver into operation:

1. Ensure that all cable connections are properly wired and secure. Verify that no metallic objects are touching the underside of the evaluation board which might cause a short-circuit.
2. Apply DC power. The GP indicator (CR6) on the transceiver board should light continuously.



3. Using a connected PC terminal, configure the unit with the proper mode (master or remote), network address and data parameters. See *Configuration Settings* below for programming details.
4. Observe the transceiver's LED indicators for proper operation. [Table 5 on Page 17](#) shows the functions and normal indications of the LEDs.
5. Verify that the transceiver is transmitting and receiving data (TXD, RXD) in response to the master station and/or connected terminal device.

## Configuration Settings

This section explains how to set the essential operating parameters of the transceiver. For more information on connecting a PC terminal and preparing it for use, refer to Section [“PROGRAMMING REFERENCE” on Page 34](#).

The three essential settings for the transceiver are as follows:

**Mode**—Master, Remote, or Extension

**Network Address**—a unique number from 1–65000

**Data Interface Parameters**—bps, data bits, parity, stop bits

Follow these steps to program the transceiver:

1. Set the Mode using the **MODE M** (Master), **MODE R** (Remote), or **MODE X** (Extension) command. (Note: There can be only *one* master radio in a system.)

For Extension (SAF) radios only: If *any* **MODE X** radios are used in the network, SAF must be turned on at the Master station. The **MODE X** radio must be programmed with an Extended Address (**XADDR**). Units that need to hear the **MODE X** radio must be programmed with an appropriate **XPRI** and/or **XMAP** value. (See [“Simple Extended SAF Network” on Page 26](#) for more information.)

2. Set a unique Network Address (1–65000) using **ADDR** command. Each radio in the system *must* have the same network address. *Tip: Use the last four digits of the master station's serial number to help avoid conflicts with other users.*
3. Set the baud rate/data interface parameters. Default setting is 9600 bps, 8 data bits, no parity, 1 stop bit. If changes are required, use the **BAUD xxxxx abc** command where **xxxxx** equals the data speed (1200–115200 bps) and **abc** equals the communication parameters as follows:
  - a** = Data bits (7 or 8)
  - b** = Parity (N for None, O for Odd, E for Even)
  - c** = Stop bits (1 or 2)

**NOTE:** 7N1, 8E2 and 8O2 are invalid interface parameters.





## Configuring Multiple Remote Units

In most installations, the Remote radios will be programmed with virtually the same set of parameters. This process can be streamlined by testing key pieces of equipment—such as the Master, Remote, and any Extensions—on a benchtop setup prior to installation. This allows you to test various configurations in a controlled environment.

Once the evaluation network is working satisfactorily, you can save the configuration of each unit in a data file on your PC's hard drive through the use of *TransNET Configuration Software*. You can then open the Remote configuration file and install it in the next Remote radio. The software prevents you from overwriting unit or other mode-specific parameters.

## LED Indicators

The LED indicators are located to the right of the transceiver's shield cover (near J3) and show important information about status of the module. The functions of LEDs are explained in [Table 5](#) below.

**NOTE:** For the LEDs to function, they must be enabled using the **LEDS ON** command. Within 16 seconds of power-up, the following indications will be seen if the unit has been properly configured and is communicating with another transceiver:

- GP lamp lit continuously
- DCD lamp lit continuously (if unit is synchronized with another station)
- Remote radio(s) transmitting data (TXD) and receiving data (RXD) with another station.

**Table 5. LED indicator descriptions**

	LED Name	Description
	RXD (CR3) Receive Data	Serial receive data activity. Payload data from connected device.
RXD	TXD (CR4) Transmit Data	Serial transmit data activity. Payload data to connected device.
TXD	DCD (CR5) Data Carrier Detect	Continuous—Radio is receiving/sending synchronization frames On within 10 seconds of power-up under normal conditions
DCD	GP (CR6) General Purpose	<ul style="list-style-type: none"> <li>• Continuous—Power is applied to the radio; no problems detected</li> <li>• Flashing (5 times-per-second)—Fault indication. See <a href="#">"TROUBLESHOOTING"</a> on <a href="#">Page 52</a></li> <li>• Off—Radio is unpowered or in Sleep mode</li> </ul>
GP		



## 4.0 EVALUATION BOARD DOCUMENTATION

This section contains an assembly drawing and parts list for the OEM Evaluation Board. Also, a foldout schematic diagram of the Board is included at the back of this manual. This documentation is provided to assist integrators who need to create compatible interface circuitry between the OEM transceiver and host equipment.

**NOTE:** The foldout schematic may also be accessed from the TransNET Support Package CD, or from our website at: [www.microwavedata.com](http://www.microwavedata.com).

### 4.1 Assembly Drawing

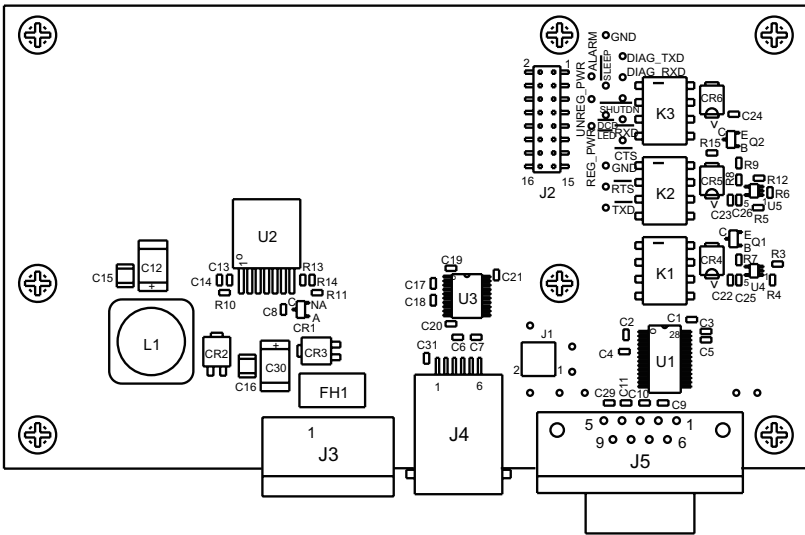

Figure 14. Evaluation Board Assembly Diagram

### 4.2 Parts List

Table 6 lists the electronic components used on the Evaluation Board.

Table 6. OEM Evaluation Board Parts List

Ref. Desig.	Part Description
CR1	DIODE, SOT23 SMALL SIG 914 5D
CR4 CR5 CR6	RECTIFIER, 30V B13
CR2 CR3	DIODE, SCHOTTKY POWER, SMT, SNGL, UPS840
Q1 Q2	TRANSISTOR, SOT23 NPN 6429 M1LR

**Table 6. OEM Evaluation Board Parts List (Continued)**

U4 U5	IC, LINEAR SC70-5 COMPARATOR SNGLE LMV33
U1	IC, IN'FACE SSOP28 RS-232 TXVR SP3238E
U3	IC, IN'FCE 20PIN TSSOP DRIVER SP3222
U2	IC, SWITCHING REG'R ADJ.4.5A LT1374HVIR
K1 K2 K3	RELAY, DPDT
R10	RESISTOR, CHIP 0603 1/16W 5% 2.2K
R4 R5 R13 R14	RESISTOR, CHIP 0603 1/10W 1% 10K
R12	RESISTOR, CHIP 0603 1/10W 1% 100K
R7 R9	RESISTOR, CHIP 0603 1/10W 1% 1.5K
R11	RESISTOR, CHIP 0603 1/10W 1% 1.82K
R3	RESISTOR, CHIP 0603 1/10W 1% 22.6K
R15	RESISTOR, CHIP 0603 1/10W 1% 31.6K
R8	RESISTOR, CHIP 0603 1/10W 1% 470 OHM
R6	RESISTOR, CHIP 0603 1/10W 1% 6.81K
C12	CAP, TANT 7343 20% 10V 100uf
C6 C7 C9 C10 C11 C29 C31	CAP, CHIP 0603 50V NPO 5% 100pf
C1 C2 C3 C4 C5 C17 C18 C19 C20 C21 C22 C23 C24 C25 C26 C8	CAP, CHIP 0603 X7R 10% 0.1uF
C13	CAP, CHIP 0603 X7R 10% 470 pf
C14	CAP, CHIP 0603 X7R 10% 4700pF
C15	Capacitor, Low ESR Chip Ceramic, 1210 22uF
C16	Capacitor, Low ESR Chip Ceramic, 1210 4.7
L1	INDUCTOR, SWITCHING, 20%, 10uH
J1	CONN, HEADER, .100 DUAL STR 4-PIN
P/O J1 1-2, P/O J1 3-4	CONN, JUMPER
FH1	FUSE HOLDER, PCB SMT W/2A SLO-BLO FUSE



**Table 6. OEM Evaluation Board Parts List (Continued)**

J2	CONN, HEADER, PC MOUNT .078, DUAL, 16 PIN Samtec TW Series, Part No: ASP 103812-01 <i>(Mates with J3 on the OEM radio transceiver)</i>
J3	CONN, TERM STRIP, 5MM PCB
J4	CONN, TELE JACK 6POS 6CON RT A SMT W/F
J5	CONN, D-SUB, PCB RCPT 90 DEGREE, 9 PIN

### 4.3 Evaluation Board Fuse Replacement

The Evaluation Board is protected by a 2 ampere fuse. The fuse can be blown by an over-current condition caused by an internal failure or over-voltage. Follow the procedure below to remove and replace the fuse:

1. Disconnect the primary power cable and all other connections to the Evaluation Board.
2. Locate the fuse holder assembly, FH1, behind the green power connector, J3.
3. Loosen the fuse from the holder using a very small screwdriver, then use a small pair of needle-nose pliers to pull the fuse straight up and out of the holder.
4. Use an ohmmeter or other continuity tester to verify that the fuse is open.
5. Install a new fuse in the holder. Replacement fuse information: Littelfuse #0454002; 452 Series, 2 Amp SMF Slo-Blo fuse (MDS Part No. 29-1784A03).



## 5.0 TRANSCEIVER MOUNTING

This section provides details for mounting the OEM transceiver in a host device. The module need only be protected from direct exposure to the weather. No additional RF shielding is required.

### 5.1 Mounting Dimensions

Figure 15 shows the dimensions of the transceiver board and its mounting holes. If possible, choose a mounting location that provides an unobstructed view of the radio's LED status indicators when viewing the board from outside the host device.

Mount the transceiver module to a stable surface using the four mounting holes at the corners of the PC board. Standoff spacers should be used to maintain adequate clearance between the bottom of the circuit board and the mounting surface. (Fasteners/anchors are not normally supplied.)

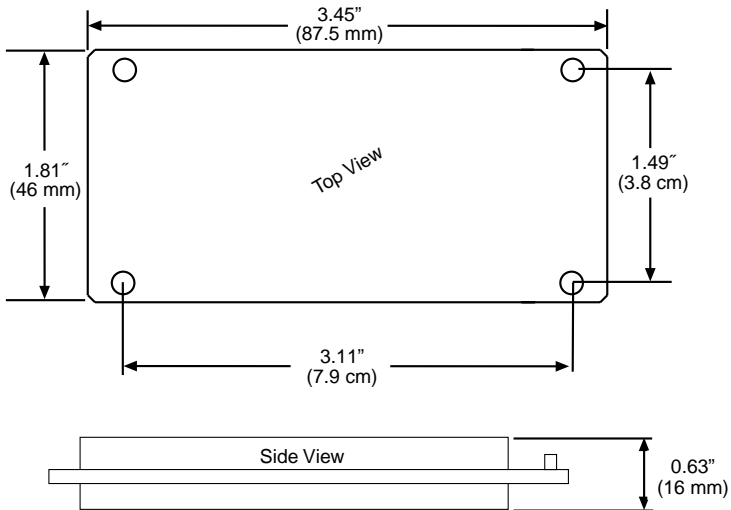

Figure 15. Transceiver Mounting Dimensions

### 5.2 Antennas & Feedlines

A number of omnidirectional and directional antennas are available for use with the radio. Contact your factory representative for specific recommendations on antenna types and hardware sources. In general, an omnidirectional antenna (Figure 16) is used at master station sites in order to provide equal coverage to all of the remote units.



At remote sites and in many point-to-point systems, a directional Yagi antenna (Figure 17) is generally recommended to minimize interference to and from other users and to maximize range.

For systems operating in a very short range environment, small, flexible whip antennas may also be supplied. Such antennas are available for direct connection to the transceiver module, or for exterior mounting with various lengths of feedline.

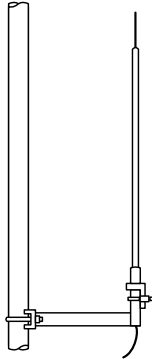

**Figure 16.**  
**Omnidirectional Antenna**  
*(shown mounted to mast)*

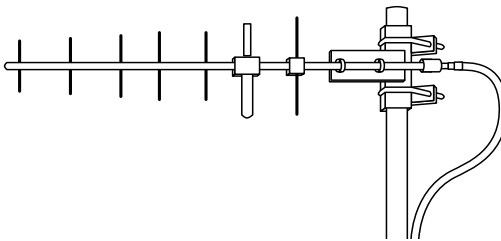

**Figure 17. Typical Yagi Antenna (shown mounted to mast)**

**Feedlines**

The feedline supplied with the antenna was carefully selected to minimize RF loss and ensure regulatory compliance with the antenna being used. Do not make substitutions or change the lengths of the antenna system feedline. If you require a different length of feedline for your installation, contact your factory representative for assistance.

**NOTE:** Strong fields near the antenna can interfere with the operation of the low level RTU circuits and change the reported values of the data being monitored. If interference is experienced, it may be necessary to re-orient the antenna with respect to the radio, RTU, sensors or other components of the system.



## 6.0 OPTIMIZING PERFORMANCE

After the basic operation of the radio has been checked, you may wish to optimize its performance using some of the suggestions given here. The effectiveness of these techniques will vary with the design of your system and the format of the data being sent.

Complete instructions for using the commands referenced in this manual are provided in “[PROGRAMMING REFERENCE](#)” on [Page 34](#).

### 6.1 Antenna Aiming

For optimum performance of directional antennas (yagis), they must be accurately aimed in the direction of desired transmission. The easiest way to do this is to point the antenna in the approximate direction, then use the remote radio’s **RSSI** command (Received Signal Strength Indicator) to further refine the heading for maximum received signal strength.

In an MAS system, RSSI readings are only meaningful when initiated from a remote station. This is because the master station typically receives signals from several remote sites, and the RSSI would be continually changing as the master receives from each remote in turn.

### 6.2 Antenna SWR Check

It is necessary to briefly key the transmitter for this check by placing the radio in the **SETUP** mode ([Page 48](#)) and using the **KEY** command. (To unkey the radio, enter **DKEY**; to disable the **SETUP** mode and return the radio to normal operation, enter **Q** or **QUIT**.)

The SWR of the antenna system should be checked before the radio is put into regular service. For accurate readings, a wattmeter suited for 1000 MHz is required. One unit meeting this criteria is the Bird Model 43 directional wattmeter with a 5J element installed.

The reflected power should be less than 10% of the forward power ( $\approx 2:1$  SWR). Higher readings usually indicate problems with the antenna, feedline or coaxial connectors.

### 6.3 Data Buffer Setting

The default setting for the data buffer is **OFF**. This allows the radio to operate with the lowest possible latency and improves channel efficiency. MODBUS and its derivatives are the only protocols that should require the buffer to be turned on. See “[BUFF \[ON, OFF\]](#)” on [Page 41](#) for details.

### 6.4 Hoptime Setting

The default hop-time setting is **7** (7 ms). An alternate setting of **28** is used to increase throughput, but at the cost of increased latency. A detailed explanation of the **HOPTIME** command can be found on [Page 44](#).



## 6.5 Operation at 115200 bps

Burst throughput at 115200 bps is supported at all settings. The radio will always buffer at least 500 characters. Sustained throughput at 115200bps is only possible when the data path is nearly error free and the operating settings have been properly selected. For sustained operation at 115200 bps, use the following settings: **SAF OFF, FEC OFF, REPEAT 0, RETRY 0, HOPTIME 28.**

## 6.6 Baud Rate Setting

The default baud rate setting is 19200 bps to accommodate most systems. If your system will use a different data rate, you should change the radio's data interface speed using the **BAUD xxxxx abc** command (Page 41). It should be set to the highest speed that can be sent by the data equipment in the system. (The transceiver supports 1200 to 115200 bps.)

## 6.7 Radio Interference Checks

The radio operates in eight frequency zones. If interference is found in one or more of these zones, the **SKIP** command (Page 49) can be used to omit them from the hop pattern. You should also review **8.0 DEALING WITH INTERFERENCE**, when interference problems are encountered.

## 6.8 RF Output Setting

OEM Transceivers are shipped from the factory with a compliant power setting for the antenna system to be used. This setting limits the maximum effective isotropic radiated power (EIRP) from the antenna to +36 dBm. For compliance with FCC and Industry Canada rules, the power level must be adjusted in accordance with **Table 7** below.

**NOTE:** In some regions, the maximum allowable RF output may differ from those stated above. Be sure to check for and comply with the requirements for your area before placing the transceiver in service.

**Table 7. Power Setting vs. Antenna System Gain  
Required to maintain FCC/IC maximum +36 dBm EIRP**

Antenna (Model No.)	Gain (dBi)	Power Setting (dBm)	Max. Power (dBm)	Minimum Length of Feedline Cable
1/2 Wave Whip Dipole (Z1527)	2.1	30	30	18-inch/0.46 meter LMR 100A cable assembly
Omni-directional Base Station (Z1526)	7.1	29	29	10 feet/3.05 meters of RG-213 cable with 18-inch/0.46 meter LMR 100A cable assembly
Yagi Directional (Z1523A, B, or C)	8.1	28	28	10 feet/3.05 meters of LMR 400 cable with 18-inch/0.46 meter LMR 100A cable assembly





## 7.0 OPERATING PRINCIPLES & SPECIAL CONFIGURATIONS

### 7.1 How Remotes Acquire Synchronization

Remotes acquire synchronization and configuration information via **SYNC** messages sent from the Master (the **MODE M** unit) or from any valid Extension (**MODE X** unit).

The Master will always transmit **SYNC** messages. An Extension will only start sending **SYNC** messages after synchronization is achieved with its Master.

The ability to synchronize to a given radio is further qualified by the sender's Extended Address (**XADDR**) and by receiver's Synchronization Qualifiers (**XMAP**, **XPRI**, and **XRSSI**).

When a primary is specified (**XPRI** is 0...31), a radio will always attempt to find the primary first. If 30 seconds elapses and the primary is not found, then the radio will attempt to synchronize with any non-primary radio in the **XMAP** list.

Once every 30 minutes, if a primary is defined, the radio will check its synchronization source. If the radio is synchronized to a unit other than the primary, then the current **RSSI** value is compared to the **XRSSI** value. If **RSSI** is less than **XRSSI** (or if **XRSSI** is **NONE**) the radio will force a loss-of-synchronization, and hunt for the primary again (as described in the previous paragraph).

By default, Extensions (and the Master) begin with **XADDR 0**. Synchronization qualifiers are set to **XMAP 0**, **XPRI 0**, and **XRSSI NONE**, respectively. This default configuration allows any radio to hear the Master. When an Extension is added, the extended address of *the Extension must be set to a unique value*. All remotes that need to hear that extension can specify this either by designating the extension as the primary (**XPRI**), or by including it in their list of valid synchronization sources (**XMAP**).

### 7.2 Establishing a Tail-End Link

A tail-end link can be used to bring an outlying remote site into the rest of an MAS network. [Figure 5 on Page 5](#) shows a diagram of this type of system.

A tail-end link is established by connecting an OEM transceiver "back-to-back" with another unit such as a licensed MDS x710 Series transceiver. The wiring connections between the two radios must be made as shown in [Figure 18](#). In addition, the **DEVICE CTS KEY** command must be asserted at the OEM radio.

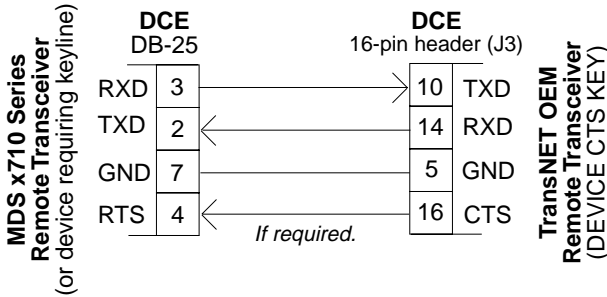

Figure 18. Data Crossover Cable for Tail-End Links

### 7.3 Store & Forward (SAF) Operation with Extension Radios

The Store-and-Forward (SAF) capability allows individual radios to act as data repeaters. SAF operates by dividing a network into a vertical hierarchy of two or more sub-networks. (See Figure 6 on Page 6.) Adjacent sub-networks are connected via Extension radios operating in “MODE X” which move data from one sub-network to the next one.

The Store-and-Forward implementation adheres to the general polling principles used in most multiple-address systems (MAS). Polls originate from the Master station, broadcast to *all* radios within the network, and travel hierarchically downward. All Remotes will hear the same message, but only one Remote will respond. Messages within a hierarchy only travel in one direction at a time.

Using SAF will cut the overall data throughput in half, however, multiple networks can be inter-connected with no additional loss in network throughput.

#### Simple Extended SAF Network

Figure 19 depicts a two-level network utilizing a single Master (M) and an Extension (X) radio. In this network, messages directed to Remotes in the “K” sub-network, will be relayed through Extension radio  $X_{j,k}$  to the K-Remotes. Any response from a Remote in sub-network “K” will pass back through Extension radio  $X_{j,k}$  to the Master  $M_j$ . Radios in sub-network “J” operate on the same set of frequencies and sub-network “K” but with a different radio-frequency hopping pattern.

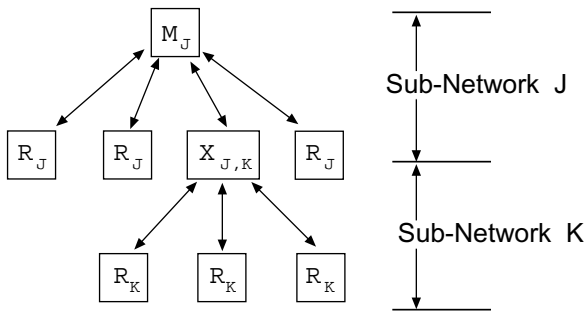
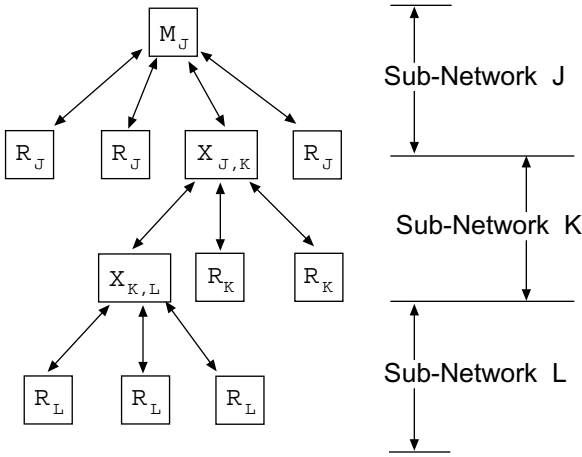

**Figure 19. Simple Extended SAF Network**  
*Networks: J and K*

In the SAF operation, the Extension radios are set to **MODE X** (*Details page 45*) and operate with a “dual personality”—50% of the time they serve as a Remote station and 50% of the time as a Master for sub-network Remotes.

### Extended SAF Network

Below is an example of a multilevel network utilizing two repeaters— $X_{J,K}$  and  $X_{K,L}$ . The example demonstrates the extensibility of the network. In this case, messages directed to Remotes in the sub-network L will be relayed through Extension radios  $X_{J,K}$  and  $X_{K,L}$ . As in the previous example, the Extension radios will split their operating time equally between their Master and Remote personalities. This multi-layered network can be extended indefinitely without degrading system throughput beyond that initially incurred by placing the network in the SAF mode.



**Figure 20. Extended SAF Network**  
*Networks: J, K, L*

**Retransmission and ARQ operation**

Functionally, the sub-network side of an Extension behaves like a corresponding connection between a master and a remote.

When an Extension is using its “master personality” it sends acknowledgments and performs unconditional retransmissions based on its **REPEAT** count.

When an Extension is using its “Remote personality”, acknowledgments are processed and retransmissions occur as needed, up to the number of times specified by the **RETRY** count value.

If new data arrives—from a new source—prior to completion of retransmissions, then this is considered a violation of the polling model protocol. The new data takes precedence over the old data and the old data is lost. In such a situation, new data is likely to be corrupt as it will have some old data mixed in with it.

**Synchronization in SAF Networks**

The Master controls the synchronization for a given network for all modes. Setting the Master to “**SAF ON**” broadcasts a command from the Master to all radio units in the associated network either directly or through an Extension radio. This command puts *all radios in the entire system* in a special time-division duplexing mode that alternates between two timeslots. One time slot for data communications upstream and another for downstream communications.



The Extensions are single radios which serve as bridges between adjacent sub-network levels. Extensions will undertake a “remote” personality in one timeslot, and a “master” personality in the alternate timeslot and provide communications with associated Remotes downstream. Extensions behave like two radios with their data ports tied together, first synchronizing with their upstream Master during their Remote personality period, and then providing synchronization signals to dependent Remotes downstream during its Master personality period.

All Remotes synchronize to a corresponding Master. This can be the “real master” (the **MODE M** unit), or it can be a repeater “Extension” that derives synchronization from the “real master.”

Payload polls/packets broadcast from the network Master will be repeated to all levels of the network, either directly to Remotes, or through network repeaters—the Extensions station. The targeted Remote will respond to the poll following the same path back to the Master.

### Configuration Parameters for Store-and Forward Services

The installation and configuration of a network with an Extension using SAF is straight-forward with only a few unique parameters that need to be considered and set at each unit.

In every network there can be only one Master station. It will serve as the sole gateway to the outside world. The following three tables detail the parameters that will need to be set on each type of radio in the network.

- Network Master Radio—[Table 8 on Page 29](#)
- Extension Radio(s)—[Table 9 on Page 30](#)
- Remote Radio(s)—[Table 10 on Page 31](#)

**Table 8. Configuration Parameters for SAF Services  
Network Master Radio**

Parameter	Command	Description
Operating Mode	<b>MODE M</b> <i>Details page 45</i>	Set the radio to serve as a Master
Network Address	<b>ADDR</b> <i>Details page 40</i>	A number between 1 and 65,000 that will serve as a common network address.  All radios in the network use the same number.



**Table 8. Configuration Parameters for SAF Services  
Network Master Radio (Continued)**

Parameter	Command	Description
Extended Address	<b>XADDR</b> <i>Details page 51</i>	A number between 0 and 31 that will serve as a common address for radios that synchronize directly to this master.  Typically, the Master is set to zero (0).
Store and Forward Mode	<b>SAF ON</b> <i>Details page 48</i>	Enables store and forward capability in the network.

**Table 9. Configuration Parameters for SAF Services  
Extension Radio(s)**

Parameter	Command	Description
Operating Mode	<b>MODE X</b> <i>Details page 45</i>	Set the radio to serve as an Extension
Network Address	<b>ADDR</b> <i>Details page 40</i>	A number between 1 and 65,000 that will serve as a common network address.  All radios in the network use the same number.
Extended Address	<b>XADDR</b> <i>Details page 51</i>	A number between 0 and 31 that will serve as a common address for radios that synchronize directly to this Extension radio serving as master for associated sub-network units.  We recommend using zero (0) for the Master station.
Primary Extended Address	<b>XPRI</b> <i>Details page 51</i>	XADDR number of the primary or preferred radio with which this radio will synchronize.
Extension Map	<b>XMAP</b> <i>Details page 51</i>	Functional list of all XADDR values with which this radio can synchronize, excluding the <b>XPRI</b> address
Extension Received Signal Strength Indicator	<b>XRSSI</b> <i>Details page 51</i>	The minimum RSSI level required to preserve synchronization with a non-primary radio. (Ineffective when XPRI is NONE)



**Table 10. Configuration Parameters for SAF Services  
Remote Radio(s)**

Parameter	Command	Description
Operating Mode	<b>MODE R</b> <i>Details page 45</i>	Set the radio to serve as a Remote station
Network Address	<b>ADDR</b> <i>Details page 40</i>	A number between 1 and 65,000 that will serve as a common network address or name.  Same number for all units in the same network.
Primary Extended Address	<b>XPRI</b> <i>Details page 51</i>	XADDR number of the primary or preferred radio with which this radio will synchronize.
Extension Map	<b>XMAP</b> <i>Details page 51</i>	A list of all XADDR values with which this radio can synchronize, excluding the <b>XPRI</b> address
Extension Received Signal Strength Indicator	<b>XRSSI</b> <i>Details page 51</i>	The minimum RSSI level required to preserve synchronization with a non-primary radio. (Ineffective when XPRI is NONE)

## 7.4 Sleep Mode Operation (*Remote units only*)

In some installations, such as at solar-powered sites, it may be necessary to keep the transceiver's power consumption to an absolute minimum. This can be accomplished using the radio's Sleep Mode feature. In this mode, power consumption is reduced to about 8 mA.

Sleep Mode can be enabled under RTU control by asserting a ground (on Pin 6 of J3, the radio's header connector). The radio stays in Sleep Mode until the low is removed, and all normal functions are suspended.

The radio can be "awakened" by your RTU every minute or so to verify synchronization with the master station. When the ground is removed, the radio will be ready to receive data within 75 milliseconds.

**NOTE:** The **SLEEP** function must be set to **ON**; otherwise a ground on the Sleep Mode pin will be ignored.



It is important to note that power consumption will increase somewhat as communication from the master station degrades. This is because the radio will spend a greater period of time “awake” looking for synchronization messages from the master radio.

In order for the radio to be controlled by the Sleep Mode pin, the radio must be set to **SLEEP ON**. See “**SLEEP [ON, OFF]**” on Page 50 for more information.

### **Sleep Mode Example**

The following example describes Sleep Mode implementation in a typical system. Using this information, you should be able to configure a system that meets your own particular needs.

Suppose you need communications to each remote site only once per hour. Program the RTU to raise an EIA/RS-232 line once each hour (DTR for example) and wait for a poll and response before lowering it again. Connect this line to Pin 6 of the radio’s header connector. This will allow each RTU to be polled once per hour, with a significant savings in power consumption.

## **8.0 DEALING WITH INTERFERENCE**

The transceiver shares the frequency spectrum with other services and other Part 15 (unlicensed) devices in the USA. As such, near 100% error free communications may not be achieved in a given location, and some level of interference should be expected. However, the radio’s flexible design and hopping techniques should allow adequate performance as long as care is taken in choosing a suitable location and in configuring the radio’s operating parameters.

In general, keep the following points in mind when setting up your communications network:

1. Systems installed in rural areas are least likely to encounter interference; those in suburban and urban environments are more likely to be affected by other devices operating in the license-free frequency band and by adjacent licensed services.
2. If possible, use a directional antenna at remote sites. They confine the transmission and reception pattern to a narrow lobe, which minimizes interference to (and from) stations located outside the pattern.
3. If interference is suspected from a nearby licensed system (such as a paging transmitter), it may be helpful to use horizontal polarization of all antennas in the network. Because most other services typically use vertical polarization in this band, an additional 20 dB of attenuation to interference can be achieved by using the horizontal plane.
4. Multiple spread spectrum systems can co-exist in close proximity to each other with only minor interference, provided they are each assigned a unique network address. Each network address has a different hop pattern associated with it.





5. If constant interference is present in a particular frequency zone, it may be necessary to “lock out” that zone from the radio’s hopping pattern. The radio includes built-in tools to help users do this. Refer to the discussion of the **SKIP** command (Page 49) for more information. In the USA, a maximum of four zones may be skipped, per FCC rules. Check the regulatory requirements for your region.
6. Interference can also come from out-of-band RF sources such as paging systems. Installation of a bandpass filter, such as Part No. 20-2822A02 in the antenna system may provide relief from this type of interference.
7. Proper use of the **RETRY** and **REPEAT** commands may be helpful in areas with heavy interference.

The **RETRY** command sets the maximum number of times (1 to 10) that a radio will re-transmit upstream data over the air. Values greater than 1 successively improve the chances of a message getting through when interference is a problem.

The **REPEAT** command sets a fixed number of unconditional retransmissions for downstream data.

8. The RF power output of all radios in a system should be set for the lowest level necessary for reliable communications. This lessens the chance of causing unnecessary interference to nearby systems and keeps power consumption to a minimum.



## 9.0 PROGRAMMING REFERENCE

All programming and control of the transceiver is performed through a PC terminal connected to the radio or the Evaluation Board DIAG connector. There are no manual adjustments or jumper settings used for configuration. This section explains how to establish terminal communication, and provides a complete list of user commands.

### 9.1 Programming Methods

#### Terminal Interface Mode

A PC may be used by operating it in a basic terminal mode (e.g., a HyperTerminal session) and entering the radio commands listed in the tables contained in this section. The PC must be connected to the radio via its 16-pin header connector, or, if using the Evaluation Board, via the modular diagnostics connector. In the latter case, an RJ-11 to DB-9 Adapter Cable (Part No. 03-3246A01) is required. A cable of this type may be constructed using the information shown in [Figure 10 on Page 11](#).

Once a PC terminal is connected, communication (baud rate) is automatically established through the command interface. To access the command interface, press the **ESCAPE** key, followed by one or more **ENTER** keystrokes (delivered at about half-second intervals), until the “>” prompt is displayed.

**NOTE:** The diagnostic interface uses 8 data bits, 1 stop bit, and no parity. It automatically configures itself to function at 1200, 2400, 4800, 9600, 19200, 38400, 57600, and 115200 bps.

If the **DLINK** setting is **ON**, the interface will start out in Diagnostic Link mode. This is a special protocol used to support Network-Wide Diagnostics. The process described in the paragraph above causes the radio to exit diagnostic link mode and enter command mode. If there is no input in command mode for 5 minutes, the interface will revert back to diagnostic link mode.

#### PC-Based Configuration Software

The Windows™-based *TransNET Configuration Software* (P/N 06-4059A01) is designed for use with the OEM Transceiver. This software provides access to all of the radio’s capabilities with the benefit of context-sensitive help. The program is shipped as part of the TransNET Support Package CD included with every order.

### 9.2 User Commands

A series of tables begin on the next page listing the various user commands for the OEM transceiver. The tables provide abbreviated command descriptions. Complete descriptions follow in [Section 9.3](#).



## Entering Commands

The proper procedure for entering commands is to type the command, followed by an **[ENTER]** keystroke. For programming commands, the command is followed by **[SPACE]**, the appropriate information or values, and then **[ENTER]**.

**Table 11. Network Configuration—Master Station**

COMMAND	DESCRIPTION
<b>BUFF [ON, OFF]</b> <i>Details, page 41</i>	ON = Seamless data OFF = Fast byte throughput.
<b>FEC [ON, OFF]</b> <i>Details, page 44</i>	Sets/disables FEC (Forward Error Correction) setting.
<b>HOPTIME [7, 28]</b> <i>Details, page 44</i>	Displays hop-time or sets it to 7 or 28 ms.
<b>REPEAT [0–10]</b> <i>Details, page 47</i>	Sets/displays the fixed downstream re-send count.
<b>RETRY [0–10]</b> <i>Details, page 47</i>	Sets/displays the maximum upstream re-send count for ARQ (Automatic Repeat Request) operation
<b>SAF [ON, OFF]</b> <i>Details, page 48</i>	Enables/disables the store-and-forward function for the network controlled by this Master unit.
<b>SKIP [NONE, 1...8]</b> <i>Details, page 49</i>	Skip one or more frequency zones

**Table 12. Network-Wide Diagnostics**

Command	Description
<b>DLINK [xxxxx/ON/OFF]</b> <i>Details, page 43</i>	Controls operation of diagnostic link function.
<b>DTYPE [NODE/ROOT]</b> <i>Details, page 44</i>	Set radio's operational characteristics for network-wide <i>diagnostics</i>

**Table 13. Operational Configuration—Set/Program**

Command	Description
<b>ADDR [1–65000]</b> <i>Details, page 40</i>	Program network address
<b>AMASK [0000 0000–FFFF FFFF]</b> <i>Details, page 41</i>	Sets alarm response. Default: FFFF FFFF
<b>ASENSE [HI/LO]</b> <i>Details, page 41</i>	Sense of the radio's alarm output in the EIA-232 mode. Default: Alarm present = HI.
<b>BAUD [xxxxx abc]</b> <i>Details, page 41</i>	Data communication parameters
<b>CODE [NONE, 1...255]</b> <i>Details, page 42</i>	Select the security/encryption setting in the radio.
<b>CTS [0–255]</b> <i>Details, page 42</i>	CTS delay in milliseconds. (A value of 0 returns CTS immediately)
<b>CTSHOLD [0–60000]</b> <i>Details, page 43</i>	"Hold time" that CTS is present following last character from DATA port.
<b>DEVICE [DCE, CTS KEY]</b> <i>Details, page 43</i>	Device behavior: DCE (normal) or CTS Key
<b>LEDS [ON, OFF]</b> <i>Details, page 45</i>	Enables/disables transceiver LEDs
<b>MODE [M, R, X]</b> <i>Details, page 45</i>	Operating mode: where M = Master, R = Remote
<b>OWM [xxxxx]</b> <i>Details, page 45</i>	Owner's message, or alternate message (30 characters maximum)
<b>OWN [xxxxx]</b> <i>Details, page 45</i>	Owner's name, or alternate message (30 characters maximum)
<b>PORT [RS232, RS485]</b> <i>Details, page 45</i>	Data port (DATA connector) interface signaling mode: RS232 or RS485
<b>PWR</b> <i>Details page 47</i>	Forward power-output setting in dBm
<b>REPEAT [0–10]</b> <i>Details, page 47</i>	Forward power output in dBm.
<b>RXTOT [NONE, 0–1440]</b> <i>Details, page 48</i>	Maximum duration (in minutes) before time-out alarm. Default is OFF.
<b>RTU [ON, OFF, 0-80]</b> <i>Details, page 48</i>	Enable or Disable unit's built-in RTU simulator. Default is OFF. Set RTU address between zero and 80.

**Table 13. Operational Configuration—Set/Program (Continued)**

Command	Description
<b>SLEEP [ON, OFF]</b> <i>Details, page 50</i>	Enable or Disable the radio's Sleep mode function.
<b>UNIT [10000–65000]</b> <i>Details, page 50</i>	Unit address used for network-wide diagnostics. (Unique within associated network.)
<b>XADDR [0–31]</b> <i>Details, page 51</i>	This unit's Extended address Typically, the Master is set to zero (0).
<b>XPRI [0–31]</b> <i>Details, page 51</i>	Address of the primary Extended radio unit (Extension).
<b>XMAP [00000000-FFFFFFFF]</b> <i>Details, page 51</i>	Included Extended units in MODE X. (Extensions and Remotes only).
<b>XRSSI [NONE, –40...–120]</b> <i>Details, page 51</i>	Minimum RSSI level required to preserve synchronization with a non-primary radio. (Only meaningful when XPRI is not NONE)
<b>ZONE CLEAR</b> <i>Details, page 51</i>	Reset zone data statistics

**Table 14. Operating Status—Display Only**

Command	Description
<b>ADDR</b> <i>Details page 40</i>	Network address
<b>AMASK</b> <i>Details page 41</i>	Alarm mask (response)
<b>ASENSE</b> <i>Details page 41</i>	Current sense of the alarm output.
<b>BAUD</b> <i>Details page 41</i>	Data communication parameters. Example: BAUD 9600 8N1
<b>BUFF</b> <i>Details page 41</i>	Data buffering mode: ON = seamless data, OFF = fast byte throughput
<b>CODE</b> <i>Details page 42</i>	Security/encryption operational status. "NONE" (Inactive), or "ACTIVE"
<b>CTS</b> <i>Details page 42</i>	CTS delay in milliseconds (0–255 ms)
<b>CTSHOLD</b> <i>Details page 43</i>	"Hold time" that CTS is present following last character from DATA port.



**Table 14. Operating Status—Display Only (Continued)**

<b>Command</b>	<b>Description</b>
<b>DEVICE</b> <i>Details page 43</i>	Device behavior Alternatives: DCE and CTS KEY
<b>HOPTIME</b> <i>Details page 44</i>	Hop-time value in milliseconds (ms).
<b>HREV</b> <i>Details, page 45</i>	Hardware revision level
<b>LEDS [ON, OFF]</b> <i>Details, page 45</i>	Enables/disables transceiver LEDs
<b>MODE</b> <i>Details page 45</i>	Current operating mode: M = Master R = Remote X = Extension (Repeater)
<b>OWM</b> <i>Details page 45</i>	Owner's message or site name
<b>OWN</b> <i>Details page 45</i>	Owner's name or system name
<b>PORT</b> <i>Details page 45</i>	Current data port (DATA connector) interface signaling mode: RS232 or RS485
<b>PWR</b> <i>Details page 47</i>	Show forward power-output setting in dBm
<b>REPEAT</b> <i>Details page 47</i>	The fixed downstream re-send count.
<b>RETRY</b> <i>Details page 47</i>	The maximum upstream re-send count for ARQ (Automatic Repeat Request) operation.
<b>SAF</b> <i>Details page 48</i>	The store-and-forward function status.
<b>SKIP</b> <i>Details page 49</i>	Table of frequency zones programmed to be skipped
<b>RSSI</b> <i>Details page 47</i>	Received signal strength indicator (dBm). Unavailable at Master unless SETUP is enabled.
<b>RXTOT</b> <i>Details page 48</i>	The amount of time (in seconds) to wait before issuing a time-out alarm.
<b>RTU</b> <i>Details page 48</i>	RTU simulator's operational status (ON/OFF)

**Table 14. Operating Status—Display Only (Continued)**

Command	Description
<b>SAF</b> <i>Details page 48</i>	Store-and-forward mode status in this unit. (ON/OFF)
<b>SER</b> <i>Details page 49</i>	Serial number of radio
<b>SHOW PWR</b> <i>Details page 49</i>	Show measured RF output power in dBm
<b>SHOW SYNC</b> <i>Details page 49</i>	Information on synchronization source and depth
<b>SKIP</b> <i>Details page 49</i>	Frequency zones that are skipped
<b>SLEEP</b> <i>Details page 50</i>	Radio's Sleep Mode setting. (At Remotes Only)
<b>SREV</b> <i>Details page 50</i>	Transceiver firmware revision level
<b>STAT</b> <i>Details page 50</i>	Current alarm status
<b>TEMP</b> <i>Details page 50</i>	Transceiver's internal temperature (°C)
<b>UNIT</b> <i>Details page 50</i>	Programmed unit address for network-wide diagnostics
<b>XADDR</b> <i>Details page 51</i>	This unit's Extended address
<b>XPRI</b> <i>Details page 51</i>	Address of the primary Extended radio unit (Extension).
<b>XMAP</b> <i>Details page 51</i>	Included Extended units in MODE X. (Extensions and Remotes only).
<b>XRSSI</b> <i>Details page 51</i>	Minimum RSSI level required to preserve synchronization with a non-primary radio. (Only meaningful when XPRI is not NONE)

**Table 15. Diagnostic and Test Functions**

Command	Description
<b>KEY</b> <i>Details, page 45</i>	Enables the transmitter test. (Radio must be in Setup mode.)
<b>DKEY</b> <i>Details, page 44</i>	Turns off the transmitter test. (Radio must be in Setup mode.)

**Table 15. Diagnostic and Test Functions (Continued)**

Command	Description
<b>TX [xxxx]</b> <i>Details, page 50</i>	Set/display transmit test frequency. (Radio must be in Setup mode.)
<b>RX [xxxx]</b> <i>Details, page 48</i>	Set/display receive test frequency. (Radio must be in Setup mode.)
<b>SETUP</b> <i>Details, page 48</i>	Enables Setup mode. Times out after 10 minutes. Press "Q" to quit.
<b>ZONE DATA</b> <i>Details, page 51</i>	Zone data statistics
<b>ZONE CLEAR</b> <i>Details, page 51</i>	Clears the Zone Data log

### 9.3 Detailed Command Descriptions

The essential commands for most applications are Network Address (**ADDR**), Mode (**MODE**), and Baud Rate (**BAUD**). However, proper use of the additional commands allows you to tailor the transceiver for a specific use, or to conduct basic diagnostics on the radio. This section gives more detailed information for the commands listed above in section 9.2.

Most of the commands below can be used in two ways. First, you can type only the command name (for example, **ADDR**) to view the currently programmed data. Second, you can set or change the existing data by typing the command, followed by a space, and then the desired entry (for example, **ADDR 1234**). In the list below, allowable programming variables, if any, are shown in brackets [ ] following the command name.

#### **ADDR [1–65000]**

This command sets or displays the radio's network address. The network address can range from 1 to 65000.

*A network address must be programmed at the time of installation and must be common across each radio in a given network. Radios are typically shipped with the network address unprogrammed, causing the address to display as **NONE**. If the address is not set (or is set to a wrong value) it leaves the system in an invalid state, preventing operation and generating an alarm.*

**NOTE:** It is recommended that the last four digits of the master radio's serial number be used for the network address. This helps avoid conflicts with other users.





## AMASK [0000 0000–FFFF FFFF]

This command sets the alarm bits that cause the alarm output signal to be triggered. The PWR LED will still flash for all alarms, but the alarm output signal will only be activated for those alarms that have the corresponding mask bit set. The hex value for the mask aligns directly with the hex value for the **ALARM** command. The default is **FFFF FFFF**. Through proper use of the **AMASK** command, it is possible to tailor the alarm response of the radio. Contact the factory for more information on configuring the alarm mask.

## A sense [HI/LO]

This command is used to set the sense of the radio's alarm output at Pin 3 of the 16-pin header connector. The default setting is HI which means an alarm exists when an RS-232 high is on Pin 3.

## BAUD [xxxxx abc]

This command sets or displays the communication attributes for the normal payload communications through the DATA port. The command has no effect on the RJ-11 DIAG(NOSTICS) port.

The first parameter (**xxxxx**) is baud rate. Baud rate is specified in bits-per-second and must be one of the following speeds: 1200, 2400, 4800, 9600, 19200, 38400, 57600, or 115200. At baud rates of 19200 bps or less, the radio can support unlimited continuous data transmission at any hop rate.

The second parameter of the **BAUD** command (**abc**) is a 3-character block indicating how the data is encoded. The following is a breakdown of each character's meaning:

- a** = Data bits (7 or 8)
- b** = Parity (**N** for None, **O** for Odd, **E** for Even)
- c** = Stop bits (1 or 2)

The factory default setting is 9600 baud, 8 data bits, no parity, 1 stop bit (Example: **19200 8N1**).

**NOTE:** 7N1, 8O2, and 8E2 are invalid communication settings and are not supported by the transceiver.

## BUFF [ON, OFF]

This command sets or displays the received data handling mode of the radio. The command parameter is either **ON** or **OFF**. (The default is **OFF**.) The setting of this parameter affects the timing of received data sent out the DATA connector. Data transmitted over the air by the radio is unaffected by the **BUFF** setting.

If data buffering is set to **OFF**, the radio will operate with the lowest possible average latency. Data bytes are sent out the DATA port as soon as an incoming RF data frame is processed. Average and typical latency will both be below 10 ms, but idle character gaps may be introduced into the outgoing data flow.



If data buffering is **ON**, the radio will operate in a seamless mode. That is, data bytes will be sent over the air as quickly as possible, but the receiver will buffer the data until the entire packet has been collected. The delay introduced by data buffering is variable and depends on message size and the number of retransmissions required, but the radio will not create any gaps in the output data stream. This mode of operation is required for protocols such as MODBUS™ that do not allow gaps in their data transmission.

Seamless mode (**BUFF ON**) is intended only for applications where the message size is 256 characters or less. Enforcement of this rule is left up to the user. If more than 256 characters are transmitted data delivery will not be seamless and data may be lost.

Changes to the **BUFF** setting may only be made at the master radio. This is because the master radio broadcasts the buffer setting for the entire network. At remote radios, the buffer setting may be read when the radio is in synchronization with the master, but it may not be changed.

### CODE [NONE, 1...255]

The **CODE** command is used to select or display the security/encryption setting in the radio.

The default is **CODE NONE**. Setting **CODE** to a value other than **NONE** provides an extra level security beyond that provided by the Network Address (**ADDR**). The disadvantage is increased complexity in managing the network.

The **CODE** command takes an argument **1...255**, or "**NONE**". Entering **CODE** without an argument will display either "**NONE**" or "**ACTIVE**". **ACTIVE** means that security/encryption has been enabled, but the radio *will not* display the security argument.

When a **CODE** value is active, *all radios in the system must use the same code value*. If the code value is not properly programmed, a remote radio will not synchronize with the master.

**CAUTION:** Record the **CODE** value and store it in a safe place. If the code is later forgotten, and a unit is to be added to the system, all radios in the network must be set to **NONE** and then reprogrammed to a new value.

### CTS [0-255]

The **CTS** (clear-to-send) command sets or displays the timer value associated with the CTS line response. The command parameter ranges from 0 to 255 milliseconds.

For DCE operation, the timer specifies how long to wait after the RTS line goes high before asserting the CTS line. A timer value of zero means that the CTS line will be asserted immediately following the assertion of RTS.

For CTS Key operation (see the **DEVICE** command), the timer specifies how long to wait after asserting the CTS line before sending data out the DATA port. A timer value of zero means that data will be sent out the data port without imposing a key-up delay. (Other delays may be in effect from other radio operating parameters.)



## CTSHOLD [0–60000]

Used in **DEVICE CTS KEY** mode, this command sets the amount of time in milliseconds that CTS remains present following transmission of the last character out the RXD pin of the DATA port. This “hold time” can be used to prevent squelch tail data corruption when communicating with other radios.

The **CTSHOLD** setting can range from 0 to 60000 (i.e., 60 seconds). The default value is 0, which means that CTS will drop immediately after the last character is transmitted. If the command is entered when the radio is in **DEVICE DCE** mode, the response **CTSHOLD N/A** will be displayed.

## DEVICE [DCE, CTS KEY]

The **DEVICE** command sets or displays the device behavior of the radio. The command parameter is either **DCE** or **CTS KEY**.

The default selection is **DCE**. In this mode, CTS will go high following RTS, subject to the CTS programmable delay time. Keying is stimulated by the input of characters at the data port. Hardware flow control is implemented by dropping the CTS line if data arrives faster than it can be transmitted.

If **CTS KEY** is selected, the radio is assumed to be controlling another radio, such as in a repeater or tail-end link system. The RTS line is ignored and the CTS line is used as a keyline control for the other radio. CTS is asserted immediately after the receipt of RF data, but data will not be sent out the DATA port until after the CTS programmable delay time has expired. (This gives the other radio time to key.)

Following transmission of the last byte of data, CTS will remain asserted for the duration specified by the **CTSHOLD** command. **CTSHOLD** should be set sufficiently high.

## DLINK [xxxxx/ON/OFF]

**DLINK ON** enables use of *Diagnostic Link* mode and establishes it as the default protocol on the RJ-11 DIAG port. *Diagnostic Link* mode is a special protocol used to support Network-Wide Diagnostics. **DLINK** must be set to **ON** to support connection to *InSite* or to support chained diagnostics between radio networks. **DLINK OFF** disables this feature. The default setting is **ON**.

The following **DLINK** baud rates selections are allowed:

- 1200      • 4800      • 9600      • 19200 (default)
- 38400    • 57600    • 115200

Example: **DLINK 4800** sets the RJ-11 DIAG port to operate at 4800 bps when diagnostics is “closed”. This setting will not affect the port’s autobaud operation. Use only of **DLINK ON**, will enable the use 19200 or the most recently programmed value. The default is **DLINK 19200** and **DLINK ON**.

**NOTE:** The same baud rate must be entered into the InSite Equipment List’s **BAUD** field.



**NOTE:** The DLINK rate must match the rate of any connected device to the diagnostic port. This may be either another radio's diagnostic port, the InSite computer, or another data link device that eventually connects to the InSite computer.

## DKEY

Disables the transmitter when it is keyed. See also **KEY** command.

## DTYPE [NODE/ROOT]

The **DTYPE** command specifies the radio's operational characteristics for network-wide diagnostics. The transceiver uses the following types:

- **NODE**—The most common setting, and the default. This is the basic system radio device-type. Typically, the radio network is comprised of nodes and one root. Intrusive diagnostics can originate from any node. However, non-intrusive diagnostics can only be conducted from the root node.
- **ROOT**—Always one, and only one, per network (including units associated through Extension units.) The root is the focal point of network-wide diagnostics information. Intrusive diagnostics can originate from any radio, including the root. However, the root is the *only* radio through which non-intrusive diagnostics can be conducted.

## FEC [ON, OFF]

This command is used to view the FEC setting, or turn it on or off. The default setting is **FEC ON**. (It needs to be turned off when throughputs exceed 57,600 bps.) FEC is set at the master and is automatically passed on to all of the remotes in a network.

Setting FEC to **ON** improves sensitivity at the cost of reduced throughput. Typical SCADA/telemetry applications use low data rates and, as such, the FEC setting is normally transparent to them.

## HOPTIME [7, 28]

The **HOPTIME** command is used to set or display the hop-time setting. The command is a digit corresponding to the hop-time setting in milliseconds. The default **HOPTIME** setting is **7**. A setting of **28** must be used when throughputs exceed 57,600 bps.

Changes to the **HOPTIME** setting may only be made at the master radio. (This is because the Master radio establishes the hop-time setting for the entire network.) At remote radios, the hop-time setting may be read when the radio is in synchronization with the master, but it may not be changed.

## INIT

The **INIT** command is used to reset the radio's operating parameters to the factory defaults listed in [Table 16 on Page 46](#). This may be helpful when trying to resolve configuration problems that resulted from the entry of one or more improper command settings. If you are unsure of which command setting caused the problem, this command allows you to get back to a known working state.



**NOTE:** Caution should be exercised when using the **INIT** command on radios in a system employing the Store-and-Forward feature. Settings relating to the use of Extension services will be lost and will need to be re-entered. Inventory and record the settings for **XADDR**, **XPRI** and **XMAP** before using the **INIT** command.

**SPECIAL NOTE:** Installing firmware of Revision 2.0 or later into a radio with Revisions 1.x firmware will preserve the radio's compatibility with other radios running Revision 1.x firmware. If updating the radio's firmware is part of a system-wide upgrade, the last step should be to use the **INIT** command at the Master station. Use of the **INIT** command causes the changes shown in [Table 16 on Page 46](#) to be applied

## HREV

Shows the Hardware revision of the radio.

## KEY

Enables the transmitter. (Radio must be in Setup mode.) See also **DKEY** command.

## LEDS [ON, OFF]

This command is used to view the LED setting, or to enable/disable LED operation. In power-critical applications (battery/solar powered sites, for example), it may be desirable to turn off the LEDs.

## MODE [M, R, X]

The **MODE** command sets or displays the operating mode of the radio. A master radio is set by **MODE M**; a remote set by **MODE R**, and an Extension is set by **MODE X**.

All units default to remotes; other modes must be specifically programmed with the **MODE** command.

If **MODE X** is used, the **MODE X** radio should be programmed with an Extended Address (**XADDR**). Units that need to hear this **MODE X** radio must be programmed with an appropriate **XPRI** and/or **XMAP** value.

## OWM [xxxxxx]

The **OWM** command sets or displays an optional owner's message, such as the system name. The entry can contain up to 30 characters.

## OWN [xxxxxx]

The **OWN** command sets or displays an optional owner's name, such as the site name. The entry can contain up to 30 characters.

## PORT [RS232, RS485]

Select or identify the current data interface signaling mode: **RS232** or **RS485**. This is the port through which the payload data will pass. Pin descriptions for EIA-232 are on [Page 13](#) and EIA-485 can be found on [Page 13](#). Note: This command will always show **TTL** if the radio is only equipped for TTL service—see model number configuration code on [Page 3](#).



## PWR [20–30]

This command displays or sets the desired RF forward output power setting of the radio. The **PWR** command parameter is specified in dBm and can range from 20 dBm through 30 in 1 dBm steps. The default setting is 30 dBm (1 watt). To read the actual (measured) power output of the radio, use the **SHOW PWR** command.

In the USA, maximum allowable power is governed by FCC limits on Effective Isotropic Radiated Power output (EIRP). The EIRP limit of +36 dBm means that any user with a net antenna gain greater than 6 dBi must decrease the **PWR** setting accordingly.

**Table 16. INIT Command Generated Defaults**

Parameter	Default Setting	Corresponding Command
<i>For all radios</i>		
Device operation	DCE	DEVICE DCE
CTS delay	0 (CTS is continuously asserted)	CTS 0
CTS hold-time	0	CTSHOLD 0
DATA Interface port	<ul style="list-style-type: none"> <li>• 9600 baud</li> <li>• 8 data bits</li> <li>• none (no parity)</li> <li>• 1 stop bit</li> </ul>	BAUD 9600 8N1
Alarm Mask	FFFF FFFF	AMASK
Alarm Output Sense	RS-232 High (+5.0 Vdc)	ASENSE
RX Time-out-Timer	None/Disable	RXTOT
Transmitter test frequency	915.000 MHz	TX xxx
Receiver test frequency	915.000 MHz	RX xxx
Sleep Enable	OFF	SLEEP OFF
Data Port Setting	RS/EIA-232	PORT RS232
Primary Extension Radio Address	0 (Master)	XPRI 0
Synchronization Source Map	None	XMAP 0
Extended Address	0	XADDR 0
<i>For MASTER radios</i>		
Skipped frequencies	None (radio will hop across all frequencies)	SKIP NONE
Hop-time	7 ms	HOPTIME 7
Buffer mode	OFF	BUFF OFF

**Table 16. INIT Command Generated Defaults (Continued)**

Parameter	Default Setting	Corresponding Command
Retry Count	10 (max. 10 repeats for ARQ)	RETRY 10
Repeat Count	3 (downstream repeats)	REPEAT 3
Forward Error Correction	ON	FEC ON

### REPEAT [0–10]

The **REPEAT** command affects “downstream” data. The command causes a Master or Extension to always repeat transmissions for the specified number of times (range is 0 to 10; default selection is 3). Unlike the **RETRY** command, there is no acknowledgment that a message has been received. To display the current setting, use the **REPEAT** command without entering a value.

### RETRY [0–10]

The **RETRY** command affects upstream data. The command selects, or displays, the maximum number of times (0 to 10) that a remote radio will re-transmit data. The default setting is 10.

This command is associated with ARQ (Automatic Repeat Request) operation of the radio and is intended for use in areas with heavy radio interference.

When the **RETRY** command is issued without parameters, the maximum retransmission count is shown. A value of 0 represents no retries, while values of 1 or greater successively improve the chance of data delivery in spectrally harsh environments (at the expense of possibly increased latency). The **RETRY** value is only settable at the Master. It is readable by a synchronized Remote.

### RSSI

This command displays the radio’s Received Signal Strength Indication in dBm (decibels relative to 1 mW). The output can range from –40 dBm to –120 dBm. Command availability and results depend on the mode of operation (master or remote). The closer to 0 dBm, the stronger the signal, thus a reading of –70 dBm is stronger than –80 dBm.

For a remote radio, under normal operation, RSSI is based on the average signal strength of the SYNC message received in each of the eight frequency zones. (RSSI is sampled each time a SYNC message is received.) When using the RSSI reading to align a directional antenna, it is important to make changes slowly so that the RSSI reading will provide meaningful results. It will take several seconds to indicate a change in signal level. The radio stays in RSSI mode until **[ENTER]** is pressed.



For a master radio, under normal operation, entering the RSSI command causes the response **NOT AVAILABLE** to be returned. This is because a master is normally receiving signals from several remote stations and an RSSI reading would be continually changing. The only exception is when the **SETUP** command has been asserted. This disables hopping and allows reading a “raw” RSSI signal level in real time from a master or remote radio.

**NOTE:** RSSI readings will not indicate signals stronger than -40 dBm.

### RTU [ON, OFF, 0-80]

This command re-enables or disables the radio’s internal RTU simulator, which runs with proprietary polling programs such as poll.exe and rsim.exe. The internal RTU simulator is available whenever a radio has diagnostics enabled. This command also sets the RTU address that the radio will respond to.

The internal RTU can be used for testing system payload data or pseudo bit error rate (BER) testing. It can be helpful in isolating a problem to either the external RTU or the radio. The default RTU setting is **OFF**.

### RX [xxxx]

This command sets or displays the test receive frequency used in place of hopping when the radio is in **SETUP** mode. The test receive frequency can be reprogrammed to any value between 902.200 MHz and 927.800 MHz, inclusive. The factory default setting is 915.000 MHz.

### RXTOT [NONE, 0-1440]

This command sets or displays the amount of time (in minutes) to wait for the next received data packet before issuing a receiver time-out alarm. The default setting is **NONE**.

### SAF [ON, OFF]

This command enables/disables the operation of the Store-and-Forward services. It can be set only at the network’s Master station, but will effect all radios in the associated network. The default setting is **OFF**. See related commands: “**XADDR [0-31]**” on Page 51, “**XPRI [0-31]**” on Page 51, and “**XMAP [00000000-FFFFFFFF]**” on Page 51.

## SETUP

This command sets up the transceiver for checking antenna SWR or transmitter power with external measuring equipment. Do not use this mode during normal operation.

When the **SETUP** command is entered, the prompt changes to **SETUP>**, and:

- Hopping is disabled.
- Synthesizer frequencies are reset to the test frequencies specified by the **TX** and **RX** commands described earlier.





- The radio can be keyed using the **KEY** command. **DKEY** is used to unkey the radio. (If the radio is left in a keyed state it is automatically unkeyed after several minutes.)
- The **RSSI** is sampled in a raw, continuous fashion regardless of whether the unit is a master or a remote.

Entering **Q** or **QUIT** returns the system to normal operation.

A timer keeps the Setup mode from accidentally leaving the system disabled. After 10 minutes the system behaves as if **Q** or **QUIT** had been entered, returning to normal operation.

## SER

Displays the Serial Number of the radio.

## SHOW PWR

The **SHOW PWR** command displays the actual (measured) RF power output in dBm. Unlike the **PWR** command, this command shows the actual level being measured, not the programmed RF power setting.

## SHOW SYNC

When used at a Remote station, this command will display **Extended Address** and **Unit Address** of the Master or Extension radio to which the Remote is synchronized. The network depth at the remote, defined as the number of downstream links from the Master, is displayed in parentheses.

## SKIP [NONE, 1...8]

This command sets or displays which, if any, of the eight 3.2 MHz-wide zones will be skipped from the radio's hopping sequence. Skipping zones is one way of dealing with constant interference on one or more frequencies. See "**DEALING WITH INTERFERENCE**" on Page 32 for more information on dealing with interference.

Table 17 shows the frequency range covered by each zone. The command parameter is either the keyword **NONE** or an undelimited string of up to four digits where each digit 1...8 represents a corresponding zone to skip. (For zone parameter input, the digits can appear in any order and can be optionally separated by a blank space.) The **SKIP** command is display-only at remote radios. (Remotes must be synchronized with the master radio to display the skip status.)

In the USA, a maximum of four zones may be skipped, per FCC rules. Check the regulatory requirements for your region.

**Table 17. Frequency Zones**

ZONE 1	ZONE 2	ZONE 3	ZONE 4	ZONE 5	ZONE 6	ZONE 7	ZONE 8
902.200 to 905.200	905.400 to 908.400	908.600 to 911.600	911.800 to 914.800	915.000 to 918.000	918.200 to 921.200	921.400 to 924.400	924.600 to 927.600



## SLEEP [ON, OFF]

This command is used to set or display the radio's Sleep Mode setting. The default setting is **SLEEP OFF**. When this mode is enabled (ON), a ground or logic low on Pin 6 of the 16-pin header connector (J3) suspends all normal radio functions, and power consumption is reduced to approximately 8 mA. The radio remains in this state until the low is removed. This function cannot be turned on for a Master or Extension radio.

## SREV

This command displays the version of the firmware currently loaded into the transceiver.

A display of **06-4040A01, 2.0.0** is an example of the firmware version identifier—part number followed by release/version number.

## STAT

This command is used to check the alarm status of the radio. If no alarms exist, the message **NO ALARMS PRESENT** is returned.

If an alarm does exist, a two-digit alarm code (00–31) is displayed and the event is identified as a “Major” or “Minor” alarm. A brief description of the event is also given.

If more than one alarm exists, the word **MORE** appears, and additional alarms may be viewed by pressing the **[ENTER]** key. Detailed descriptions of the alarm codes are provided in [Table 18 on Page 53](#).

## TEMP

This command displays the internal temperature of the transceiver in degrees Celsius. (Note that the radio is specified to operate in an environment between –30 C° and +60 C°). This internal reading may be higher than the outside temperature by several degrees.

## TX [xxxx]

This command sets or displays the test transmit frequency used in place of hopping whenever the radio is in Setup mode. The test transmit frequency can be reprogrammed to any value between 902.200 MHz and 927.800 MHz, inclusive. The factory default setting is 915.000 MHz.

## UNIT [10000–65000]

This command sets the unit addressing for network-wide diagnostics. The unit address is factory programmed to the last four digits of the serial number. If re-programmed in the field, the entry must consist of five digits between 10000 and 65000.



## XADDR [0–31]

Display or program the Extended Address of this radio that will serve as a common address for the sub-network synchronized to this Master or Extension. This value can be listed in the **XPRI** parameter of associated Extension or Remote radios to allow them to synchronize to this radio. We recommend setting the Master to zero (0). It is easy to remember, and is the default address when the INIT command is used. (Programmed only in Master and Extension radios.)

## XMAP [00000000-FFFFFFFF]

XMAP is a 32-bit hex entry where the least significant bit represents XADDR 0 and the most significant bit represents XADDR 31. The full 32-bit hex value represents the entire list of extensions with which the radio will be allowed to communicate. (Remotes and Extensions only.)

This parameter is easily programmed through the *TransNET Configuration Software's* **Store and Forward Settings** panel.

## XPRI [0–31]

Display or program the extended address of a primary radio with which this radio will attempt to synchronize and communicate. A setting of **NONE** will allow the unit to synchronize with any Master or Extension in the **XMAP** list. (Parameter only meaningful for a Remote or Extension.)

## XRSSI [NONE, -40...-120]

The XRSSI command is used to set the RSSI minimum signal level required to preserve synchronization with a non-primary Extension radio. This parameter will be ignored if XPRI is set to NONE.

## ZONE CLEAR

The **ZONE CLEAR** command clears the zone data for *all* zones in the Zone Data Log, resetting the count to 0. (Zone data is also cleared automatically upon reboot.)

## ZONE DATA

The transceiver divides its frequency operating spectrum into eight 3.2 MHz-wide zones. (These are the same zones referenced by the **SKIP** command described earlier.) Data frame statistics are maintained for each zone to indicate the transmission quality of data through the network. This information is useful for identifying zones where significant interference exists.

Zone quality information can be accessed using the **ZONE DATA** command. For each zone (1–8), it shows you the number of data frames sent, the number received, and the number received with errors. If an excessive number of errors are seen in one or more frequency zones, it may indicate interference, and you should consider “skipping” those zones using the **SKIP** command.

Note: If a frequency zone has been skipped, all counts for that zone will be zeros.



The ZONE DATA format is displayed as follows:

```

1:TX TOTAL 00000000
1:RX TOTAL 00000000
1:RX ERROR 00000000
x:
x:
x:
8:TX TOTAL 00000000
8:RX TOTAL 00000000
8:RX ERROR 00000000

```

All data is based on payload packets. Incoming network data may be divided up into multiple packets for over-the-air transfers. The number before the colon represents the zone. **TX TOTAL** is the transmit packet total. **RX TOTAL** is the receive packet total. **RX ERROR** is the total number of received packets with CRC errors. All zone data is reset with the **ZONE CLEAR** command.

## 10.0 TROUBLESHOOTING

Successful troubleshooting of the radio system is not difficult, but requires a logical approach. It is best to begin troubleshooting at the master station, as the rest of the system depends on the master for polling instructions and synchronization data. If the master station has problems, the operation of the entire network will be affected.

When communication problems are found, it is good practice to begin by checking the simple things. All radios in the network must meet these basic requirements:

- Adequate and stable primary power
- An efficient and properly aligned antenna system
- Secure connections (RF, data & power)
- Proper programming of the radio's operating parameters, especially Mode selection (**MODE**), Network Address (**ADDR**), and interface Baud Rate (**BAUD**)
- The correct interface between the radio and the connected data equipment (proper cable wiring, data format and timing).
- In store-and-forward systems there are several areas that must be carefully evaluated:
  - Duplicate **XADDR** values on **MODE M** and **MODE X** radios will cause failures unless the radios are far enough apart to not hear each other.
  - Errors in the synchronization qualifiers, **XPRI** and **XMAP**, on corresponding Remote radios.
  - **SAF** must be enabled at the Master



## 10.1 Alarm Codes

When an alarm condition exists, the transceiver creates an alarm code. These codes can be very helpful in resolving many system difficulties.

### Checking for Alarms—STAT command

To check for the presence of alarms, enter **STAT**. If no alarms exist, the message **NO ALARMS PRESENT** appears at the top of the display.

If an alarm does exist, a two-digit alarm code (00–31) is displayed, and it is identified as a major or minor alarm. A brief description of the alarm is also given. Alarm codes and their meanings are listed in [Table 18](#).

If more than one alarm exists, the word **MORE** appears at the bottom of the screen; additional alarms can be viewed by pressing **[ENTER]**.

### Major Alarms vs. Minor Alarms

Major alarms report serious conditions that generally indicate a hardware failure, or other abnormal condition that will prevent (or seriously hamper) further operation of the transceiver.

With the exception of alarm code 00 (network address not programmed), major alarms generally indicate the need for factory repair. Contact your factory representative for further assistance.

Minor alarms report conditions which, under most circumstances, will not prevent transceiver operation. This includes out-of-tolerance conditions, baud rate mismatches, etc. The cause of these alarms should be investigated and corrected to prevent system failure.

### Alarm Code Definitions

[Table 18](#) contains a listing of all event codes that may be reported by the transceiver. Additional alarm codes may be used in future firmware releases or are used by the factory.

**Table 18. Alarm Codes**

Alarm Code	Alarm Type	Description
00	Major	The network address is not programmed.
01	Major	Improper firmware detected for this radio model.
04	Major	One or more of the programmable synthesizer loops is reporting an out-of-lock condition.
08	Major	The system is reporting that it has not been calibrated. Factory calibration is required for proper radio operation.
10	Major	The DSP was unable to properly program the system to the appropriate defaults. A hardware problem may exist.
12	Major	Receiver time-out alarm.
16	Minor	The unit address is not programmed.



**Table 18. Alarm Codes (Continued)**

Alarm Code	Alarm Type	Description
17	Minor	A data parity fault has been detected on the DATA connector. This usually indicates a parity setting mismatch between the radio and the RTU.
18	Minor	A data framing error has been detected on the DATA connector. This may indicate a baud rate mismatch between the radio and the RTU.
29	Minor	RF output power fault detected. (Power differs by more than 2 dB from set level.) Often caused by high antenna system SWR. Check antenna, feedline and connectors.
30	Minor	The system is reporting an RSSI reading below -105 dBm.
31	Minor	The transceiver's internal temperature is approaching an out-of-tolerance condition. If the temperature drifts outside of the recommended operating range, system operation may fail.

## 10.2 LED Indicators

The LED indicators on the transceiver board (CR3, CR-4, CR-5 and CR-6) are an important troubleshooting tool and should be checked whenever a problem is suspected. [Table 19](#) describes the function of each status LED.

**Table 19. LED indicator descriptions**

	LED Name	Description
	RXD (CR3) Receive Data	Serial receive data activity. Payload data from connected device.
RXD	TXD (CR4) Transmit Data	Serial transmit data activity. Payload data to connected device.
TXD	DCD (CR5) Data Carrier Detect	Continuous—Radio is receiving/sending synchronization frames On within 10 seconds of power-up under normal conditions
DCD	GP (CR6) General Purpose	<ul style="list-style-type: none"> <li>Continuous—Power is applied to the radio; no problems detected</li> <li>Flashing (5 times-per-second)—Fault indication. See <a href="#">“TROUBLESHOOTING” on Page 52</a></li> <li>Off—Radio is unpowered or in Sleep mode</li> </ul>
GP		

## 10.3 Troubleshooting Chart

[Table 20](#) provides suggestions for resolving system difficulties that may be experienced in the radio system. If problems persist, contact the factory for further assistance. Refer to the inside back cover of this guide for contact information.



**Table 20. Troubleshooting chart**

Difficulty	Recommended System Checks
Unit is inoperative.	<ul style="list-style-type: none"> <li>a. Check for the proper supply voltage at the transceiver, J3 Pins 5 and 11.</li> <li>b. If using the Evaluation Board, the surface mount fuse may have opened. Refer to <a href="#">Section 4.3</a> below for replacement instructions.</li> </ul>
Interference is suspected.	<ul style="list-style-type: none"> <li>a. Verify that the system has a unique network address. Nearby systems with the same address will cause interference.</li> <li>b. Check for interference and lockout any affected zone(s) using the <b>SKIP</b> command (<a href="#">Page 49</a>).</li> <li>c. If omnidirectional antennas are used on remote stations, consider changing to directional antennas. This will often limit interference to and from other stations.</li> </ul>
No synchronization with master, or poor overall performance.	<ul style="list-style-type: none"> <li>a. Check for secure interface connections at the radio and the connected device.</li> <li>b. Check the antenna, feedline and connectors. Reflected power should be less than 10% of the forward power reading (SWR <math>\approx</math> 2:1 or lower).</li> <li>c. If the remote radio is in synchronization, but performance is poor, check the received signal strength using the <b>RSSI</b> command (<a href="#">Page 47</a>). If RSSI is low, it may indicate antenna problems, or misalignment of directional antenna headings.</li> <li>d. Verify proper programming of system parameters: mode, network address, data interface baud rate, transmitter power, CTS delay, etc. For store-and-forward applications, also verify the following: <b>SAF</b> is <b>ON</b>; extended address is properly programmed at each extension; remotes are using the proper values for <b>XPRI</b> and <b>XMAP</b>.</li> <li>e. Check for alarms using the <b>STAT</b> command (<a href="#">Page 50</a>)</li> </ul>
BER is too high. Data throughput is spotty.	<ul style="list-style-type: none"> <li>a. The <b>RETRY</b> and <b>REPEAT</b> commands may be increased to deal with interference, or decreased to increase throughput and reduce latency.</li> <li>b. Try turning on FEC. FEC on gives some coding gain, but comes at the cost of reduced throughput.</li> </ul>
Latency is too high.	<ul style="list-style-type: none"> <li>a. Reduce the REPEAT count.</li> <li>b. Turn BUFF OFF. BUFF ON insures that no gaps occur in the data, but this comes at the cost of increased latency.</li> <li>c. Make sure <b>HOPTIME</b> is set to 7.</li> </ul>

## 10.4 Network-Wide Remote Diagnostics

Diagnostics data from a remote radio can be obtained by connecting a laptop or personal computer running *InSite* diagnostics software (V6.6 or later) at any radio in the network.



**NOTE:** The diagnostics feature may not be available in all radios. The ability to query and configure a radio via Network-wide Diagnostics is based on the feature options purchased in the radio being polled.

If a PC is connected to any radio in the network, intrusive polling (polling which briefly interrupts payload data transmission) can be performed. To perform diagnostics without interrupting payload data transmission, connect the PC to a radio defined as the “root” radio. A radio is defined as a root radio using the **DTYPE ROOT** command locally, at the radio.

A complete explanation of remote diagnostics can be found in the *Network-Wide Diagnostics System Handbook* (Part No. 05-3467A01).

**Table 21. Network-Wide Diagnostics Commands**

Command	Description
<b>DLINK [xxxxx/ON/OFF]</b> <i>Details, page 43</i>	Set baud rate of diagnostics link
<b>DTYPE [NODE/ROOT]</b> <i>Details, page 44</i>	Set radio's operational characteristics for network-wide diagnostics

1. Program one radio in the network as the root radio by entering the **DTYPE ROOT** command at the radio.
2. At the root radio, use the **DLINK ON** and **DLINK [baud rate]** commands to configure the diagnostic link protocol on the RJ-11 port.
3. Program all other radios in the network as nodes by entering the **DTYPE NODE** command at each radio.
4. Use the **DLINK ON** and **DLINK [baud rate]** commands to configure the diagnostic link protocol on the RJ-11 port of each node radio.
5. Connect a PC on which *InSite* software is installed to the root radio, or to one of the nodes, at the radio's diagnostics port.

To connect a PC to the radio's DIAG port, an RJ-11 to DB-9 adapter (Part No. 03-3246A01) is required. If desired, an adapter cable may be constructed from scratch, using the information shown in [Figure 10 on Page 11](#).

6. Launch the *InSite* program at the PC. (Refer to the *InSite* user's manual for details.)





## 11.0 FIRMWARE UPGRADES

From time to time, the factory releases new firmware for its radio products. An upgraded file can be installed in existing radios to take advantage of engineering improvements or additional features.

### 11.1 Obtaining new firmware

The latest firmware for each radio type may be obtained free of charge from our website: [www.microwavedata.com/service/technical/support/downloads/](http://www.microwavedata.com/service/technical/support/downloads/).

Firmware is also available on disks from the factory that are bundled with an installation utility (*Radio Software Upgrade*—*upgrade.exe*) for transferring the firmware file on the disk to the radio.

#### Saving a Web-site firmware file to your PC

Firmware upgrades are distributed as a plain-text (ASCII) file with a “.S28” extension. Browse to find the desired “.S28” file for your radio on the factory website at [www.microwavedata.com](http://www.microwavedata.com). After finding your selection, use the right mouse button to select a path on your computer on which to save the file. (If this isn’t done, your browser may display the firmware file contents as text on the screen instead of downloading it to your local hard drive.)

After the “.S28” file has been saved to your computer, you may use either *TransNET Configuration Software* or *Radio Software Upgrade programs* to install this firmware in your radios.

### 11.2 Installing firmware in your radio

1. Connect a PC to radio’s diagnostic interface.
2. Start the *TransNET Configuration Software*. Open diagnostics port to the radio. The program will automatically read the radio’s profile.
3. From the **File** menu select **Radio Firmware Upgrade** and follow the prompts to install the new firmware into the radio. Do not press the **Cancel** button once the installation has started or it will leave the radio without any code. When the installation is complete, another radio may be connected to your PC and programmed.

**NOTE:** If a firmware installation fails, the radio is left unprogrammed and inoperative. This is indicated by the PWR LED flashing slowly (1 second on/1 second off). This condition is only likely to occur if there is a power failure to the computer or radio during the installation process. The installation should be attempted again.

## 12.0 Security

Today, the operation and management of an enterprise is becoming increasingly dependent on electronic information flow. An accompanying concern becomes the security of the communication infrastructure and the security of the data itself. We take this matter seriously, and provide several means for protecting the data carried over our wireless products.



Our radios address this issue primarily through the use of the following items:

- 1) A proprietary modem/data link layer—Data signals are processed using code and hardware specifically designed by the manufacturer.
- 2) A unique Network Address—This provides a unique identifier for each radio in a network. A radio is not addressable unless this unique code is included in the data string.
- 3) An optional encryption value (code)—Setting an encryption code requires the use of the **CODE** command. This command scrambles the radio's hop pattern and encrypts payload data content. A radio requires the correct Network Address (**ADDR**) and **CODE** value in order to synchronize. When the **CODE** command is used, the same value must be programmed into all radios in the network. See "**CODE [NONE, 1...255]**" on Page 42 for more details.

The effective combination of **CODE** and **ADDR** discourage the use of an exhaustive search to gain access to a system.

The items described above provide sufficient security for most systems. For highly-sensitive applications, system designers should consider employing application level encryption into their polling protocols to further protect their systems. Third party software tools are available for adding encryption, and these should be considered as part of any advanced encryption scheme.

## 13.0 Product Specifications

### GENERAL

---

Frequency Hopping Range:	Up to 128 frequencies within 902–928 MHz, configurable in 3.2 MHz zones
Hop Pattern:	Based on network address
Frequency Stability:	±1.5 ppm
Half-Duplex Operation:	±1.6 MHz TX/RX split
Network Addresses:	65,000
Temperature Range:	–40° C to +70° C
Humidity:	<95% at +40° C; non-condensing
Primary Power:	13.8 Vdc (6–30 Vdc range)
Current Draw (typical):	
Transmit:	510 mA @ 13.8 Vdc
Receive:	115 mA @ 13.8 Vdc
Sleep Mode:	8 mA @ 13.8 Vdc
Physical Dimensions:	1.81"W x 3.45"L x 0.63"H (46 x 87.5 x 16 mm)
Agency Approvals:	<ul style="list-style-type: none"> <li>• FCC Part 15.247 (E5MDS-EL806)</li> <li>• FCC Modular Approval</li> <li>• Industry Canada RSS-210 and RSS-139 (CAN 3738A-MDSEL806)</li> </ul>

---



## DATA CHARACTERISTICS

---

Data Interface:	RS-232/422/485
Interface Connector:	16 pin header, female
Data Rate:	1200, 2400, 4800, 9600, 19200, 38400, 57600, 115200 bps asynchronous
Data Latency:	7 ms (typical)
Byte Length:	10 or 11 bits
Maximum Data Transmission:	Continuous up to 115200 bps

## RF CHARACTERISTICS

---

### TRANSMITTER:

Power Output (at antenna connector):	1.0 Watt (+30 dBm) Max. Reference <a href="#">Table 7 on Page 24</a>
Duty Cycle:	Continuous
Modulation Type:	Binary CPFSK
Output Impedance:	50 Ohms
Spurious:	-60 dBc
Harmonics:	-55 dBc

### RECEIVER:

Type:	Double conversion superheterodyne
Sensitivity:	-110 dBm
Intermodulation:	54 dB minimum (EIA)
Desensitization:	75 dB
Spurious:	70 dB minimum
Bandwidth:	200 kHz
Interference Ratio (SINAD degraded by 3dB):	Co-channel:-10 dB Adjacent channel:+30 dB Two channels away:+40 dB Three channels away:+48 dB
Time Required to Synchronize with Master Radio:	0.5 seconds (typical)

## 13.1 Detailed Pin Descriptions

The tables in this section give detailed pin functions for the transceiver's 16-pin header connector, J3 (see [Figure 21](#)). The tables are organized according to the available signaling configurations of the OEM transceiver. ([Figure 2 on Page 3](#) may be used to determine which configuration you have.) Signaling configuration is hardware fixed at the time of manufacture and will be one of the following:

- TTL signaling for *both* Payload and Diagnostic data
- Payload data TTL; Diagnostic data RS-232
- Payload data RS-232/RS-485 selectable; Diagnostic data RS-232

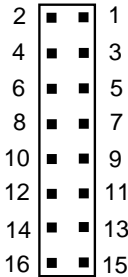

**Figure 21. 16-pin Header Connector (J3) on OEM Transceiver Board**

(See parts list (Page18) for information on matching connector)

**Table 22. Transceiver Connector J3 Pinouts**  
(Payload data TTL; Diagnostic data TTL)

Pin No.	Input/Output	Signal Type	Name/Description
1	IN	--	<b>Ground</b> —Connects to ground (negative supply potential).
2	OUT	TTL, 3 Vdc	<b>Diagnostic TXD</b> —Supplies received diagnostic/administrative data to the connected device.
3	OUT	TTL, 3 Vdc	<b>Alarm condition</b> —A low indicates normal operation. A high indicates an alarm. (See ASENSE [HI/LO] command for more information.)
4	IN	TTL, 3 Vdc	<b>Diagnostic RXD</b> —Accepts diagnostic/administrative data from the connected device.
5	IN	--	FCC 5-25 Vdc version: <b>DC Input (5-25 Vdc)</b> —Supply Source must be capable of furnishing at least 7.5 watts.  Non-FCC 3 Vdc version: <b>Do not connect</b>
6	IN	TTL, 3 Vdc	<b>Sleep Mode Input</b> —A ground on this pin turns off most circuits in a remote radio. This allows for greatly reduced power consumption, yet preserves the radio’s ability to be brought quickly back on line. See “ <a href="#">Sleep Mode Operation (Remote units only)</a> ” on Page 31 for details.
7	OUT	TTL, 3 Vdc	<b>Data Carrier Detect (DCD)</b> —A low indicates hopping synchronization has been achieved.
8	IN	TTL, 3 Vdc	<b>Power Supply Shutdown Control</b> —A ground on this pin causes the OEM module’s power supply to shut down.
9	--	--	Non-FCC 3 Vdc version: <b>DC Input (Regulated 3.3 Vdc)</b> —Supply Source must be capable of furnishing at least 7.5 watts.  FCC 5-25 Vdc version: <b>Do not connect</b>



**Table 22. Transceiver Connector J3 Pinouts**  
(Payload data TTL; Diagnostic data TTL) (Continued)

10	IN	TTL, 3 Vdc	<b>Transmitted Data (TXD)</b> —Accepts payload data from the connected device.
11	IN	--	FCC 5-25 Vdc version: <b>DC Input (5-25 Vdc)</b> —Supply Source must be capable of furnishing at least 7.5 watts.  Non-FCC 3 Vdc version: <b>Do not connect</b>
12	IN	TTL, 3 Vdc	<b>Request to Send (RTS)</b> —A high causes CTS to follow after the programmed CTS delay time has elapsed (DCE).
13	--	--	Reserved—Do not connect.
14	OUT	TTL, 3 Vdc	<b>Received Data (RXD)</b> —Supplies received payload data to the connected device.
15	IN	--	<b>Ground</b> —Connects to ground (negative supply potential).
16	OUT	TTL, 3 Vdc	<b>Clear to Send (CTS)</b> —Goes high after the programmed CTS delay time has elapsed (DCE), or keys an attached radio when RF data arrives (CTS KEY).

**Table 23. Transceiver Connector J3 Pinouts**  
(Payload data TTL; Diagnostic data RS-232)

Pin No.	Input/Output	Signal Type	Name/Description
1	IN	--	<b>Ground</b> —Connects to ground (negative supply potential).
2	OUT	RS-232	<b>Diagnostic TXD</b> —Supplies received diagnostic/administrative data to the connected device.
3	OUT	TTL, 3 Vdc	<b>Alarm condition</b> —A low indicates normal operation. A high indicates an alarm. (See ASENSE [HI/LO] command for more information.)
4	IN	RS-232	<b>Diagnostic RXD</b> —Accepts diagnostic/administrative data from the connected device.
5	IN	--	FCC 5-25 Vdc version: <b>DC Input (5-25 Vdc)</b> —Supply Source must be capable of furnishing at least 7.5 watts.  Non-FCC 3 Vdc version: <b>Do not connect</b>



**Table 23. Transceiver Connector J3 Pinouts**  
*(Payload data TTL; Diagnostic data RS-232) (Continued)*

6	IN	TTL, 3 Vdc	<b>Sleep Mode Input</b> —A ground on this pin turns off most circuits in a remote radio. This allows for greatly reduced power consumption, yet preserves the radio’s ability to be brought quickly back on line. See “ <a href="#">Sleep Mode Operation (Remote units only)</a> ” on Page 31 for details.
7	OUT	TTL, 3 Vdc	<b>Data Carrier Detect (DCD)</b> —A low indicates hopping synchronization has been achieved.
8	IN	TTL, 3 Vdc	<b>Power Supply Shutdown Control</b> —A ground on this pin causes the OEM module’s power supply to shut down.
9	--	--	Reserved—Do not connect.
10	IN	TTL, 3 Vdc	<b>Transmitted Data (TXD)</b> —Accepts payload data from the connected device.
11	IN	--	FCC 5-25 Vdc version: <b>DC Input (5-25 Vdc)</b> —Supply Source must be capable of furnishing at least 7.5 watts.  Non-FCC 3 Vdc version: <b>Do not connect</b>
12	IN	TTL, 3 Vdc	<b>Request to Send (RTS)</b> —A high causes CTS to follow after the programmed CTS delay time has elapsed (DCE).
13	--	--	Reserved—Do not connect.
14	OUT	TTL, 3 Vdc	<b>Received Data (RXD)</b> —Supplies received payload data to the connected device.
15	IN	--	<b>Ground</b> —Connects to ground (negative supply potential).
16	OUT	TTL, 3 Vdc	<b>Clear to Send (CTS)</b> —Goes high after the programmed CTS delay time has elapsed (DCE), or keys an attached radio when RF data arrives (CTS KEY).



**Table 24. Transceiver Connector J3 Pinouts**  
(Payload data RS-232; Diagnostic data RS-232)

Pin No.	Input/ Output	Signal Type	Name/Description
1	IN	--	<b>Ground</b> —Connects to ground (negative supply potential).
2	OUT	RS-232	<b>Diagnostic TXD</b> —Supplies received diagnostic/administrative data to the connected device.
3	OUT	TTL, 3 Vdc	<b>Alarm condition</b> —A low indicates normal operation. A high indicates an alarm. (See ASENSE [HI/LO] command for more information.)
4	IN	RS-232	<b>Diagnostic RXD</b> —Accepts diagnostic/administrative data from the connected device.
5	IN	--	FCC 5-25 Vdc version: <b>DC Input (5-25 Vdc)</b> —Supply Source must be capable of furnishing at least 7.5 watts.  Non-FCC 3 Vdc version: <b>Do not connect</b>
6	IN	TTL, 3 Vdc	<b>Sleep Mode Input</b> —A ground on this pin turns off most circuits in a remote radio. This allows for greatly reduced power consumption, yet preserves the radio's ability to be brought quickly back on line. See "Sleep Mode Operation (Remote units only)" on Page 31 for details.
7	OUT	TTL, 3 Vdc	<b>Data Carrier Detect (DCD)</b> —A low indicates hopping synchronization has been achieved.
8	IN	TTL, 3 Vdc	<b>Power Supply Shutdown Control</b> —A ground on this pin causes the OEM module's power supply to shut down.
9	--	--	Reserved—Do not connect.
10	IN	RS-232, +/- 5 Vdc	<b>Transmitted Data (TXD)</b> —Accepts payload data from the connected device.
11	IN	--	FCC 5-25 Vdc version: <b>DC Input (5-25 Vdc)</b> —Supply Source must be capable of furnishing at least 7.5 watts.  Non-FCC 3 Vdc version: <b>Do not connect</b>
12	IN	RS-232, +/- 5 Vdc	<b>Request to Send (RTS)</b> —A high causes CTS to follow after the programmed CTS delay time has elapsed (DCE).



**Table 24. Transceiver Connector J3 Pinouts**  
*(Payload data RS-232; Diagnostic data RS-232) (Continued)*

13	--	--	Reserved—Do not connect.
14	OUT	RS-232, +/- 5 Vdc	<b>Received Data (RXD)</b> —Supplies received payload data to the connected device.
15	IN	--	<b>Ground</b> —Connects to ground (negative supply potential).
16	OUT	RS-232, +/- 5 Vdc	<b>Clear to Send (CTS)</b> —Goes high after the programmed CTS delay time has elapsed (DCE), or keys an attached radio when RF data arrives (CTS KEY).

**Table 25. Transceiver Connector J3 Pinouts**  
*(Payload data RS-485; Diagnostic data RS-232)*

Pin No.	Input/Output	Signal Type	Name/Description
1	IN	--	<b>Ground</b> —Connects to ground (negative supply potential).
2	OUT	RS-232	<b>Diagnostic TXD</b> —Supplies received diagnostic/administrative data to the connected device.
3	OUT	TTL, 3 Vdc	<b>Alarm condition</b> —A low indicates normal operation. A high indicates an alarm. (See ASENSE [HI/LO] command for more information.)
4	IN	RS-232	<b>Diagnostic RXD</b> —Accepts diagnostic/administrative data from the connected device.
5	IN	--	FCC 5-25 Vdc version: <b>DC Input (5-25 Vdc)</b> —Supply Source must be capable of furnishing at least 7.5 watts.  Non-FCC 3 Vdc version: <b>Do not connect</b>
6	IN	TTL, 3 Vdc	<b>Sleep Mode Input</b> —A ground on this pin turns off most circuits in a remote radio. This allows for greatly reduced power consumption, yet preserves the radio's ability to be brought quickly back on line. See " <a href="#">Sleep Mode Operation (Remote units only)</a> " on Page 31 for details.
7	OUT	TTL, 3 Vdc	<b>Data Carrier Detect (DCD)</b> —A low indicates hopping synchronization has been achieved.
8	IN	TTL, 3 Vdc	<b>Power Supply Shutdown Control</b> —A ground on this pin causes the OEM module's power supply to shut down.
9	--	--	Reserved—Do not connect.





**Table 25. Transceiver Connector J3 Pinouts**  
*(Payload data RS-485; Diagnostic data RS-232) (Continued)*

10	IN	Differential	<b>RXD+/RXA (Transmitted Data+)</b> —Non-inverting receiver input. Accepts payload data from the connected device.
11	IN	--	FCC 5-25 Vdc version: <b>DC Input (5-25 Vdc)</b> —Supply Source must be capable of furnishing at least 7.5 watts.  Non-FCC 3 Vdc version: <b>Do not connect</b>
12	IN	Differential	<b>RXD-/RXA (Transmitted Data-)</b> —Inverting receiver input.
13	--	--	Reserved—Do not connect.
14	OUT	Differential	<b>TXD+/TXA (Received Data+)</b> —Non-inverting driver output. Supplies received payload data to the connected device.
15	IN	--	<b>Ground</b> —Connects to ground (negative supply potential).
16	OUT	Differential	<b>TXD-/TXA (Received Data-)</b> —Inverting driver output.



# 14.0 dBm-Watts-Volts Conversion Chart

Table 26 is provided as a convenience for determining the equivalent voltage or wattage of an RF power expressed in dBm with 50 Ohms load.

**Table 26. dBm-Watts-Volts Conversion Chart**

dBm	V	Po	dBm	V	Po	dBm	mV	Po	dBm	μV	Po
+53	100.0	200W	0	.225	1.0mW	-49	0.80		-98	2.9	
+50	70.7	100W	-1	.200	.80mW	-50	0.71	.01μW	-99	2.51	
+49	64.0	80W	-2	.180	.64mW	-51	0.64		-100	2.25	.1pW
+48	58.0	64W	-3	.160	.50mW	-52	0.57		-101	2.0	
+47	50.0	50W	-4	.141	.40mW	-53	0.50		-102	1.8	
+46	44.5	40W	-5	.125	.32mW	-54	0.45		-103	1.6	
+45	40.0	32W	-6	.115	.25mW	-55	0.40		-104	1.41	
+44	32.5	25W	-7	.100	.20mW	-56	0.351		-105	1.27	
+43	32.0	20W	-8	.090	.16mW	-57	0.32		-106	1.18	
+42	28.0	16W	-9	.080	.125mW	-58	0.286				
+41	26.2	12.5W	-10	.071	.10mW	-59	0.251		<b>dBm</b>	<b>nV</b>	<b>Po</b>
+40	22.5	10W	-11	.064		-60	0.225	.001μW	-107	1000	
+39	20.0	8W	-12	.058		-61	0.200		-108	900	
+38	18.0	6.4W	-13	.050		-62	0.180		-109	800	
+37	16.0	5W	-14	.045		-63	0.160		-110	710	.01pW
+36	14.1	4W	-15	.040		-64	0.141		-111	640	
+35	12.5	3.2W	-16	.0355					-112	580	
+34	11.5	2.5W				<b>dBm</b>	<b>μV</b>	<b>Po</b>	-113	500	
+33	10.0	2W	<b>dBm</b>	<b>mV</b>	<b>Po</b>	-65	128		-114	450	
+32	9.0	1.6W	-17	31.5		-66	115		-115	400	
+31	8.0	1.25W	-18	28.5		-67	100		-116	355	
+30	7.10	1.0W	-19	25.1		-68	90		-117	325	
+29	6.40	800mW	-20	22.5	.01mW	-69	80		-118	285	
+28	5.80	640mW	-21	20.0		-70	71	.1nW	-119	251	
+27	5.00	500mW	-22	17.9		-71	65		-120	225	
+26	4.45	400mW	-23	15.9		-72	58			.001pW	
+25	4.00	320mW	-24	14.1		-73	50		-121	200	
+24	3.55	250mW	-25	12.8		-74	45		-122	180	
+23	3.20	200mW	-26	11.5		-75	40		-123	160	
+22	2.80	160mW	-27	10.0		-76	35		-124	141	
+21	2.52	125mW	-28	8.9		-77	32		-125	128	
+20	2.25	100mW	-29	8.0		-78	29		-126	117	
+19	2.00	80mW	-30	7.1	.001mW	-79	25		-127	100	
+18	1.80	64mW	-31	6.25		-80	22.5	.01nW	-128	90	
+17	1.60	50mW	-32	5.8		-81	20.0		-129	80	.1fW
+16	1.41	40mW	-33	5.0		-82	18.0		-130	71	
+15	1.25	32mW	-34	4.5		-83	16.0		-131	61	
+14	1.15	25mW	-35	4.0		-84	11.1		-132	58	
+13	1.00	20mW	-36	3.5		-85	12.9		-133	50	
+12	.90	16mW	-37	3.2		-86	11.5		-134	45	
+11	.80	12.5mW	-38	2.85		-87	10.0		-135	40	
+10	.71	10mW	-39	2.5		-88	9.0		-136	35	
+9	.64	8mW	-40	2.25	.1μW	-89	8.0		-137	33	
+8	.58	6.4mW	-41	2.0		-90	7.1	.001nW	-138	29	
+7	.500	5mW	-42	1.8		-91	6.1		-139	25	
+6	.445	4mW	-43	1.6		-92	5.75		-140	23	.01fW
+5	.400	3.2mW	-44	1.4		-93	5.0				
+4	.355	2.5mW	-45	1.25		-94	4.5				
+3	.320	2.0mW	-46	1.18		-95	4.0				
+2	.280	1.6mW	-47	1.00		-96	3.51				
+1	.252	1.25mW	-48	0.90		-97	3.2				



# GLOSSARY

---

**Antenna System Gain**—A figure, normally expressed in dB, representing the power increase resulting from the use of a gain-type antenna. System losses (from the feedline and coaxial connectors, for example) are subtracted from this figure to calculate the total antenna system gain.

**ARQ**—Automatic Repeat Request. An error-correction technique whereby flawed data packets are detected and a request for re-transmission is issued.

**Bit**—The smallest unit of digital data, often represented by a one or a zero. Eight bits (plus start, stop, and parity bits) usually comprise a byte.

**Bits-per-second**—*See BPS.*

**BPS**—Bits-per-second. A measure of the information transfer rate of digital data across a communication channel.

**Byte**—A string of digital data usually made up of eight data bits and start, stop, and parity bits.

**Decibel (dB)**—A measure of the ratio between two signal levels. Frequently used to express the gain (or loss) of a system.

**Data Circuit-terminating Equipment**—*See DCE.*

**Data Communications Equipment**—*See DCE.*

**Data Terminal Equipment**—*See DTE.*

**dB<sub>i</sub>**—Decibels referenced to an “ideal” isotropic radiator in free space. Frequently used to express antenna gain.

**dB<sub>m</sub>**—Decibels referenced to one milliwatt. An absolute unit used to measure signal power, as in transmitter power output, or received signal strength.

**DCE**—Data Circuit-terminating Equipment (or Data Communications Equipment). In data communications terminology, this is the “modem” side of a computer-to-modem connection. By default, MDS transceivers are set as DCE devices.

**Digital Signal Processing**—*See DSP.*

**DSP**—Digital Signal Processing. DSP circuitry is responsible for the most critical real-time tasks; primarily modulation, demodulation, and servicing of the data port.

**DTE**—Data Terminal Equipment. A device that provides data in the form of digital signals at its output. Connects to the DCE device.

**Equalization**—The process of reducing the effects of amplitude, frequency or phase distortion with compensating networks.

**Extended Address**—A user-selectable number between 0 and 31 that identifies a group of transceivers that are part of a common sub-network. It is recommended the Master be assigned XADDR 0 and the values of 1-31 assigned to Extension radios.



**Extension Radio**—A radio in a TransNET spread-spectrum network that serves as a gateway between vertically adjacent sub-networks. *See Store-and-Forward.*

**Fade Margin**—The greatest tolerable reduction in average received signal strength that will be anticipated under most conditions. Provides an allowance for reduced signal strength due to multipath, slight antenna movement or changing atmospheric losses. A fade margin of 20 to 30 dB is usually sufficient in most systems.

**Frame**—A segment of data that adheres to a specific data protocol and contains definite start and end points. It provides a method of synchronizing transmissions.

**Frequency Hopping**—The spread spectrum technique used by the transceiver, wherein two or more associated radios change their operating frequencies several times per second using a set pattern. Since the pattern appears to jump around, it is said to “hop” from one frequency to another.

**Frequency Zone**—The transceivers use up to 128 discrete channels in the 902 to 928 MHz spectrums. A group of 16 channels is referred to as a zone. The transceivers use five to eight frequency zones.

**Hardware Flow Control**—A transceiver feature used to prevent data buffer overruns when handling high-speed data from the RTU or PLC. When the buffer approaches overflow, the radio drops the clear-to-send (CTS) line, which instructs the RTU or PLC to delay further transmission until CTS again returns to the high state.

**Host Computer**—The computer installed at the master station site, which controls the collection of data from one or more remote sites.

**Latency**—The delay (usually expressed in milliseconds) between when data is applied to TXD (Pin 2) at one radio, until it appears at RXD (Pin 3) at the other radio.

**MAS**—Multiple Address System. A radio system where a central master station communicates with several remote stations for the purpose of gathering telemetry data.

**Master (Station)**—The one radio transceiver in a spread spectrum network that automatically provides synchronization information to one or more associated remote transceivers. A radio may be programmed for either master or remote mode using software commands.

**Multiple Address System (MAS)**—*See Point-Multipoint System.*

**Network Address**—User-selectable number between 1 and 65000 that is used to identify a group of transceivers that form a communications network. The master and all remotes within a given system must have the same network address.

**Point-Multipoint System**—A radio communications network or system designed with a central control station that exchanges data with a number of remote locations equipped with terminal equipment.



**Poll**—A request for data issued from the host computer (or master PLC) to a remote radio.

**PLC**—Programmable Logic Controller. A dedicated microprocessor configured for a specific application with discrete inputs and outputs. It can serve as a host or as an RTU.

**Remote Radio**—A radio in a spread spectrum network that communicates with an associated master station. A radio may be programmed for either master or remote mode using software commands.

**Remote Terminal Unit**—*See RTU.*

**Repeater**—A radio that receives RF data and retransmits it. *See Store-and-Forward.*

**RTU**—Remote Terminal Unit. A data collection device installed at a remote radio site.

**SCADA**—Supervisory Control And Data Acquisition. An overall term for the functions commonly provided through an MAS radio system.

**Standing Wave Ratio**—*See SWR.*

**Sub-Network**—A group of transceivers and the corresponding radio that they are directly synchronized to. A sub-network can be identified by Extended Address. *See Store-and-Forward.*

**Store-and-Forward**—A radio that receives RF data and retransmits it. In the TransNET product line, store and forward is defined as a network that consists of vertically adjacent sub-networks that alternate communicating upstream and downstream. The transceiver performs store and forward at the internal data frame level (not the user data level) which allows the equipment to stream data with minimal latency through each Extension/Repeater radio station.

**SWR**—Standing Wave Ratio. A parameter related to the ratio between forward transmitter power and the reflected power from the antenna system. As a general guideline, reflected power should not exceed 10% of the forward power ( $\approx 2:1$  SWR).

**TTL**—Transistor-Transistor Logic. A form of digital switching that utilizes bipolar transistors to sense “high” and “low” logic levels (1 and 0, respectively).

**Zone**—*See Frequency Zone.*





# INDEX

## A

- Accessories (table) 6
- ADDR command (set/display radio network address) 40
- Alarm
  - checking for 53
  - code definitions 53
  - codes 53
  - codes, table 53
  - major vs. minor 53
  - receiver timeout (RXTOT command) 48
  - reset output signal 41
  - set/display output sense (ASENSE command) 41
  - status (STAT command) 50
- ALARM command (superseded; see STAT command) 50
- AMASK command (configure alarm output signal) 41
- Antenna
  - performance optimization 23
  - selection 21
  - SWR check 23
  - Yagi, illustrated 22
- ASENSE command (set/display alarm output sense) 41

## B

- BAUD command (set/display data interface port attributes) 41
- Baud rate
  - setting 24
  - setting for RJ-11 DIAG port (DLINK command) 56
- Benchtop Setup & Evaluation 7-??
- BUFF command (set/display received data handling mode) 41

## C

- Cable
  - data equipment to DATA INTERFACE connector 21, 34
  - data interface wiring for tail-end links 26
  - feedlines 22
  - maximum length, recommended 13,

14

- CODE command (display/set encryption value) 42
- Commands
  - ADDR (set/display radio network address) 40
  - AMASK (configure alarm output signal) 41
  - ASENSE (set/display alarm output sense) 41
  - BAUD (set/display data interface port attributes) 41
  - BUFF (set/display received data handling mode) 41
  - CODE (set/display encryption value) 42
  - CTS (set/display CTS line response timer) 42
  - CTSHOLD (set/display CTS hold timer) 43
  - detailed descriptions 40-51
  - DEVICE (set/display DCE or CTS Key behavior) 43
  - display operating status 36
  - DKEY (disable transmitter) 44
  - DTYPE (set radio's diagnostics type) 44
  - FEC (Forward Error Correction) 44
  - HOPTIME (set/display hoptime setting) 44
  - how used 40
  - INIT (restore factory default settings) 44
  - MODE (display/set radio mode as master, remote, or extension) 45
  - most often used commands 40
  - network configuration 35
  - OWM (set/display optional owner's message) 45
  - OWN (set/display optional owner's name) 45
  - PORT (display/set current data port) 45
  - PWR (set/display RF forward output power) 46, 47
  - RSSI (display received signal strength) 47
  - RTU (enable/disable internal RTU) 48
  - RX (set/display test receive



- frequency) 48
  - RXTOT (set/display received data timeout value) 48
  - SAF (store-and-forward) 48
  - SETUP (enter testing and setup mode) 48
  - SHOW (display measured power output) 49
  - SKIP (set/display frequency zone to skip) 49
  - SLEEP (display/set radio's sleep mode setting) 50
  - SREV (display transceiver software version) 50
  - STAT (list alarms) 50
  - TEMP (display internal temperature) 50
  - XADDR (display or program extended address) 51
  - XMAP (32-bit hex list of extensions) 51
  - XPRI (display/program primary radio's extended address) 51
  - XRSSI (sets minimum signal level for sync. with non-primary extension unit) 51
- D**
- Data buffer setting 23, 41
  - DATA INTERFACE
    - connector pin descriptions, table 13
  - Data interface
    - cable wiring for tail-end links, illustrated 26
  - Default settings
    - data interface baud rate 24
    - factory settings reset by INIT command (table) 46
    - restoring (INIT command) 44
    - See also individual command descriptions*
  - DEVICE command (set/display DCE or CTS Key behavior) 43
  - Diagnostics
    - setup mode (SETUP command) 48
    - using InSite software for network-wide 55
  - Display
    - alarm output sense (ASENSE command) 41
    - alarms (STAT command) 50
    - CTS hold timer value (CTSHOLD command) 43
    - CTS line response timer value (CTS command) 42
    - data interface baud rate (BAUD command) 41
    - device behavior (DEVICE command) 43
    - hoptime setting (HOPTIME command) 44
    - network address (ADDR command) 40
    - operating status commands 36
    - owner's message (OWM command) 45
    - owner's name (OWN command) 45
    - received data handling mode (BUFF command) 41
    - received data timeout value (RXTOT command) 48
    - received signal strength (RSSI command) 47
    - RF forward output power (PWR command) 46, 47
    - RF power output, actual measured (SHOW command) 49
    - skipped frequency zones (SKIP command) 49
    - software version, transceiver (SREV command) 50
    - temperature, internal (TEMP command) 50
    - test receive frequency (RX command) 48
  - display/set radio mode as master, remote, or extension (see MODE command) 45
  - DKEY command (disable transmitter) 23, 44, 49
  - DLINK command (set/display baud rate of diagnostics link) 56
  - DSP (digital signal processing) 53
  - DTYPE command (set radio's diagnostics type) 44, 56
- E**
- Enable
    - internal RTU (RTU command) 48
    - network-wide diagnostics,





- procedures 56
- Setup mode (SETUP command) 48
- skipped zone (SKIP command) 49
- Encryption. See CODE command
- Equipment List 43
- Evaluation Board
  - Documentation 18–20
- Extension radio. See Store-and-Forward (SAF)

## F

- Feedline
  - selection 21, 22

## G

- Gate (radio diagnostics type) 44

## H

- Hoptime
  - setting 23, 24
- HOPTIME command (set/display hoptime setting) 44

## I

- Illustrations
  - antenna, Yagi 22
  - data interface cable wiring for tail-end links 26
  - model configuration code 3
  - point-to-point link 4
  - remote station arrangement 10
  - tail-end link 5
  - typical MAS network 4
- INIT command (restore factory default settings) 44
- InSite software 55
- Installation 21–32
  - connecting transceiver to data equipment 21, 34
  - feedline selection 22
  - performance optimization 23
  - tail-end links 25
- Interference
  - about 32
  - checks 24
  - troubleshooting 55

## K

- Key
  - set to CTS keying (DEVICE

- command) 43
- transmitter, for antenna SWR check 23
- KEY command (key transmitter) 23, 49

## L

- LED status indicators
  - table 17, 54

## M

- Master Station
  - default settings 46
- MODE command (display/set radio mode as master, remote, or extension) 45
- MODE command (display/set radio's operating mode as master, remote, or extension) 45
- Model configuration code, illustrated 3
- Mounting instructions/dimensions 21
- Multiple Address System (MAS) network, illustrated 4

## N

- Network configuration commands 35
- Node (radio diagnostics type) 44

## O

- Operating Commands 34–52
- OWM command (set/display optional owner's message) 45
- OWN command (set/display optional owner's name) 45

## P

- PC
  - connecting to radio's diagnostic port 56
  - launching InSite application at 56
- Peer (radio diagnostics type) 44
- Performance optimization 23
- Pins, DATA INTERFACE connector descriptions (table) 13
- Point-to-point system
  - link, illustrated 4
- PORT command (set/display current data port) 45
- Power (RF)
  - how much can be used 24



- Measurement 49
  - set/display RF forward output (PWR command) 46, 47
- Procedures
  - antenna aiming 23
  - antenna and feedline selection 21
  - antenna SWR check 23
  - connecting data equipment to DATA INTERFACE connector 21, 34
  - connecting PC and radios for network-wide diagnostics 56
  - installation 21–32
  - interference check 24
  - mounting the transceiver 21
  - performance optimization 23
  - programming radio for network-wide diagnostics 56
  - troubleshooting 52–55
- Programming 34–52
- Programming radio
  - as root or node 56
- PWR command (set/display RF forward output power) 46, 47
- R**
- Radio
  - inoperative (troubleshooting chart) 55
  - no synchronization with master (troubleshooting chart) 55
  - poor performance (troubleshooting chart) 55
- Remote radio
  - default settings 46
- Remote station
  - typical arrangement, illustrated 10
- Repeater Operation. See Store-and-Forward (SAF)
- Root (radio diagnostics type) 44
- RSSI command (display received signal strength) 47
- RTU command (enable/disable internal RTU) 48
- RX command (set/display test receive frequency) 48
- RXTOT command (set/display received data timeout value) 48
- S**
- SAF command (store-and-forward) 48
- See also Encryption 42
- Set
  - alarm output sense (ASENSE command) 41
  - alarm output signal (AMASK command) 41
  - CTS hold timer (CTSHOLD command) 43
  - CTS line response timer (CTS command) 42
  - data interface baud rate (BAUD command) 41
  - DCE or CTS Key device behavior (DEVICE command) 43
  - frequency zone to skip (SKIP command) 49
  - hoptime (HOPTIME command) 44
  - network address (ADDR command) 40
  - owner's message (OWM command) 45
  - owner's name (OWN command) 45
  - radio mode (see MODE command) 45
  - received data handling mode (BUFF command) 41
  - received data timeout value (RXTOT command) 48
  - test receive frequency (RX command) 48
  - testing mode (SETUP command) 48
- SETUP command (enter testing and setup mode) 48
- SHOW command (display power output) 49
- SKIP command (set/display frequency zone to skip) 49
- SLEEP command (display/set radio's sleep setting) 50
- Spread spectrum, basic principles of 3
- SREV command (display transceiver software version) 50
- STAT command (list alarms) 50
- Store-and-Forward (SAF) 5, 26, 29, 35, 38, 39, 45, 48, 52
- SWR (Standing Wave Ratio)
  - performance optimization 23
- Synchronization qualifiers 25, 52

**T**

## Tables

- accessories 6
- alarm codes 53
- DATA INTERFACE connector pin descriptions 13
- LED status indicators 17, 54
- troubleshooting 55

## Tail-end link

- cable wiring for, illustrated 26
- illustrated 5
- installation 25

## Technical specifications 58–59

## TEMP command (display internal temperature) 50

## Temperature, display internal (TEMP command) 50

## Transceiver

connecting to data equipment 21, 34

default settings 46

mounting

instructions/dimensions 21

performance optimization 23

## Troubleshooting 52–55

table 55

**X**

## XADDR (extended address

command) 16, 25, 30, 39, 45, 46, 51, 52

## XMAP command (32-bit hex entry) 51

## XPRI command (display/set extended address) 51

## XRSSI command (sets minimum RSSI level to maintain sync. w/non-primary extension radio) 51



## ***IN CASE OF DIFFICULTY...***

---

MDS products are designed for long life and trouble-free operation. However, this equipment, as with all electronic equipment, may have an occasional component failure. The following information will assist you in the event that servicing becomes necessary.

### **CUSTOMER ASSISTANCE**

---

Assistance for MDS products is available from our Customer Support Team during business hours (8:00 A.M.–5:30 P.M. Eastern Time). When calling, please give the complete model number of the radio, along with a description of the trouble/symptom(s) that you are experiencing. In many cases, problems can be resolved over the telephone, without the need for returning the unit to the factory. Please use one of the following means for product assistance:

Phone: 585 241-5510  
FAX: 585 242-8369

E-Mail: [techsupport@microwavedata.com](mailto:techsupport@microwavedata.com)  
Web: [www.microwavedata.com](http://www.microwavedata.com)

### **FACTORY SERVICE**

---

Component level repair of radio equipment is not recommended in the field. Many components are installed using surface mount technology, which requires specialized training and equipment for proper servicing. For this reason, the equipment should be returned to the factory for any PC board repairs. The factory is best equipped to diagnose, repair and align your radio to its proper operating specifications.

If return of the equipment is necessary, you will be issued a Service Request Order (SRO) number. The SRO number will help expedite the repair so that the equipment can be repaired and returned to you as quickly as possible. Please be sure to include the SRO number on the outside of the shipping box, and on any correspondence relating to the repair. No equipment will be accepted for repair without an SRO number.

A statement should accompany the radio describing, in detail, the trouble symptom(s), and a description of any associated equipment normally connected to the radio. It is also important to include the name and telephone number of a person in your organization who can be contacted if additional information is required.

The radio must be properly packed for return to the factory. The original shipping container and packaging materials should be used whenever possible. All factory returns should be addressed to:

Microwave Data Systems  
Product Service Department  
(SRO No. XXXX)  
175 Science Parkway  
Rochester, NY 14620 USA

When repairs have been completed, the equipment will be returned to you by the same shipping method used to send it to the factory. Please specify if you wish to make different shipping arrangements. To inquire about an in-process repair, you may contact our Product Services Group at 585-241-5540 (FAX: 585-242-8400), or via e-mail at [ProductServices@microwavedata.com](mailto:ProductServices@microwavedata.com).

**industrial/wireless/performance**



Microwave Data Systems Inc.  
175 Science Parkway  
Rochester, NY 14620  
General Business: +1 585 242-9600  
FAX: +1 585 242-9620  
Web: [www.microwavedata.com](http://www.microwavedata.com)



*A product of Microwave Data Systems Inc.*