

# MDS LW700 Integrator's Guide

## 1.0 INTRODUCTION

The LW700 (Figure 1), is a fixed location (not intended for mobile use), multi-modem system operating in licensed bands between 757-758MHz and 787-788MHz, using channel bandwidths of 195kHz, 315kHz, and 570kHz. OFDM modulation choices for each bandwidth include QPSK and 16QAM variants. Maximum power and modem speed is based on frequency, modem choice, and the applicable emission mask. Transmit operation in a normal running system is governed by a Media Access Control Protocol, with distributed control functionality between AP and remotes, such that all stations act to control the emissions and operation of other stations in the system.

The unit is designed for use inside data equipment to provide reliable connectivity in wireless networks. The LW700 power control circuit ensures that the RF output is linear and never exceeds +30 dBm (+/- 0.2dBm) channel power at the antenna connector. The module is designed for **OEM use only**. Host systems must be professionally installed. Host systems must be factory configured by the OEM to operate at the correct frequency and output power setting. Refer to the table at the end of this guide to determine applicable antenna types and the RF output power allowed.

## 1.1 Transceiver Features

The LW700 maximizes performance and flexibility in wireless networks, offering the following key features:

- Selectable frequency (757-758MHz and 787-788MHz), see Table 5 for Center Frequency Channel Limits
- Selectable bandwidth (Option 4 = 195kHz, Option 3 = 315kHz, Option 2 = 570kHz)
- Selectable modem choices:  
QPSK rate  $\frac{1}{2}$  with 2x frequency repetition, QPSK rate  $\frac{1}{2}$ , QPSK rate  $\frac{3}{4}$ , 16QAM rate  $\frac{1}{2}$ , 16QAM rate  $\frac{3}{4}$
- RSSI readback indicator
- Store-and-Forward repeater operation
- Same hardware for Master, Remote, or Store-and-Forward configurations
- Supports RS/EIA-232(TTL), Ethernet, and USB user interfaces
- Operates at 5.25 Vdc at the MiniPCIe card edge power connections and 10-60Vdc at the 3-pin power connector.

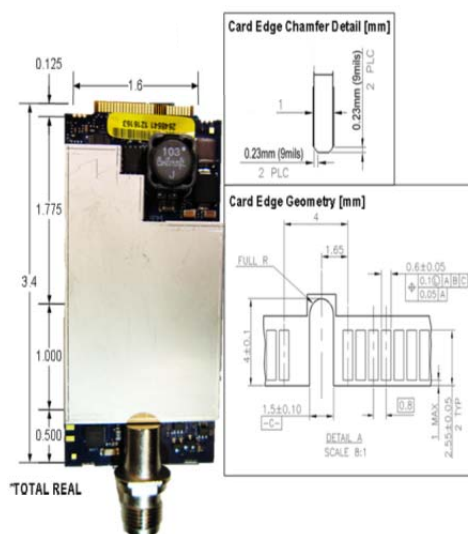

**Figure 1. LW700 Transceiver Module**  
(Mini PCI-Express Card Edge for Data/Power/& I/O and J700 Antenna)

**NOTE:** Some features may not be available on all units, based on the options purchased, or regulatory constraints in the country of operation.

## 2.0 INSTALLATION

The transceiver is designed for installation in existing electronic equipment. The I/O and 5.25v power connections are made through the Mini PCI-Express card edge. The 10-60v power is provided through a separate 3-pin connector on the bottom of the module. The transceiver mounts to the host heatsink assembly using two #4 screws inside the RF can area. The required heatsink contact area on the bottom surface of the PCB has the solder mask removed for proper heat transfer.

Only one cable connection is required to the radio for the J700 Antenna connector. The module has three optionally populated status LEDs (CR100, CR101, and CR1000) that indicate operating mode details. These LEDs provide important information that is useful during startup and optimization of the radio link.

Antennas used with the radio can be either a Yagi directional type (often used at remote sites), an omni-directional Monopole type used for short range applications or at Master stations, or a Sectorized panel type common for Master stations. See section 5.4 for Antenna Offerings and contact your sales representative for any further information.

Follow these steps to install the transceiver module:

1. Power down the Host assembly the module is being installed in to.
2. Mate the MiniPCIe card edge of the module into the socket on the Host assembly.
3. Secure the module to the heatsink surface using two #4 screws through the mounting holes in the corners of the RF can area on the radio's PC board.
4. Install the RF shield over the transceiver section.
5. Select and install an appropriate antenna and feedline for your system coverage requirements.
6. Connect the antenna coaxial lead to J700 on the module. It accepts a Type-TNC male coaxial connector.
7. Host Power Supply Requirements:
  - a. Input power applied on the 52-pin connector (J1100) must be a regulated **5.25 Vdc** (-/+0.05 V).
  - b. Input power applied on 3-pin connector (J900) must not exceed the range **10.0-60.0Vdc**
    - i. Nominal Input power on J900 is in the range 12-52Vdc - **FCC CFR 47 2.1055(d)(1)**

See Table 1 for power supply interface connections.

52-Pin GE MDS NIC Card Edge	
Pin	Description
1, 6, 7, 10, 11, 13, 12, 14, 16, 19, 20, 23, 25, 28, 30, 31, 32, 33, 36, 38, 42, 44, 45, 46, 47, 48, 49, 51	GPIO (Includes Ethernet & Serial)  *Consult Factory Documentation for specific details
2, 24, 39, 41, 52	+5.0V
3, 5, 8, 17, 22	NC
4, 9, 15, 18, 21, 26, 27, 29, 34, 35, 37, 40, 43, 50	GND

3-Pin GE MDS (J900) connector	
Pin	Description
1	GND
2, 3	+10.0-60.0V

Table 1. LW700 Power Supply Connections

8. Set the radio's basic configuration with a PC terminal through the Host system. The essential settings for all transceivers are (See Section 3 for commands):
  - **Bandwidth (Option), Modem (MCS), TX & RX Center Frequencies, Power, and Operating Mode**
    - **See Table 5 for Center Frequency Channel Limits**
9. In a normally operating system, you will see the CR101 POWER LED turn on at start-up.
10. Optimize the installation by checking:
  - Antenna aiming and RSSI check
  - Optimal modem rate setting

## 3.0 RADIO PROGRAMMING

There are no manual adjustments on the radio. All programming and control is performed through a PC connected to the Host platform that interfaces with the radio's J1100 MiniPCIe card edge connector.

### 3.1 User Commands

The following tables provide descriptions of the various user commands for the transceiver.

Command	Description	Notes
<b>ABOUT</b>	Displays NIC version build time and date.	
<b>HELP</b>	Displays all available commands.	
<b>RESET</b>	Software reset.	
<b>SER</b>	Display the NIC serial number.	
<b>MODEM</b>	Display/set NIC modem selection.	<i>[OPTION 2-4] Set bandwidth [MCS 2-6] Set modulation scheme</i>
<b>TEST PER</b>	Starts a Packet Error Rate Test.	<i>[-a] Destination test address [-n] Number of packets to send [-l] Length of each packet</i>
<b>UPTIME</b>	Display the amount of time since last power cycle.	
<b>KEY</b>	Transmits un-modulated CW	
<b>KEYR</b>	Transmits modulated random data	
<b>DKEY</b>	Disables active transmission	
<b>STAT</b>	Displays NIC TX and RX Statistics	
<b>RSSI</b>	Instantaneous RSSI reading	<i>dB</i>
<b>OPMODE [TEST, MAC1/2, IDLE]</b>	Display/set NIC operating mode.	<i>Test Mode used for Engineering and Manufacturing Test; Idle Mode = unit disabled. MAC1/2 for normal operation</i>
<b>TX [val]</b>	Read/write TX frequency	<i>[val] - frequency in MHz</i>
<b>RX [val]</b>	Read/write RX frequency	<i>[val] - frequency in MHz</i>
<b>TCXO</b>	Read TCXO tuning voltage	<i>[arg1] - Tuning voltage in V</i>
<b>TCXO CAL [arg1]</b>	Calibrate TCXO tuning voltage (Factory Only)	<i>[arg1] - Tuning voltage in V</i>

**Table 2. LW700 User Commands**

## 4.0 DC INPUT REQUIREMENTS

### 4.1 Power Consumption Ratings

The module has the following nominal power consumption ratings when operated at the required (V\_NIC) input voltage of 5.25 Vdc (-0.05/+0.05 V tolerance) and the required secondary input voltage of 10.0-60.0 Vdc on J900:

Active Receive Mode: 200mA

Transmit Mode (Worst Case Load): 1.3 Amperes

#### Power Regulation must be met by OEM to satisfy LMA conditions:

OEM Integrator should consult with Product Support for individual circuit implementations. The input voltage on the 3-pin J900 connector accepts a wide range and routes to onboard regulator on the LW700 module, but the V\_NIC input on the 52-pin connector must be carefully regulated.

At minimum, OEM Integrators must regulate the DC voltage applied to +5.25 Vdc (V\_NIC), with a tolerance of -0.05/+0.05 Vdc. This can be achieved using a voltage regulator similar to the Texas Instruments LMR12020, which is a precision DC regulator. The external +5.25 VDC input is connected via pins 2, 24, 39, 41, and 52 of the 52 pin MiniPCIe card edge connector. The transmitter uses a closed-loop power detection circuit that ensures the peak RF band power will never exceed +30dBm (+/- 0.2dBm).

The input voltage range of the LMR12020 device in this configuration is 10V to 15V. Using switched-mode power conversion technology, the LMR12020 can step down to voltages as low as 1.13V from a 10V input bus, with typically less than 1 W of power dissipation. The output voltage must be set to a voltage of 5.25V, using an external trim resistor. Operating features of the TI device include cycle-by-cycle current limiting, under-voltage lockout (UVLO), on/off inhibit, output overcurrent protection, and over-temperature protection.

For example purposes, a circuit employing this method of regulation is shown below in schematic form.

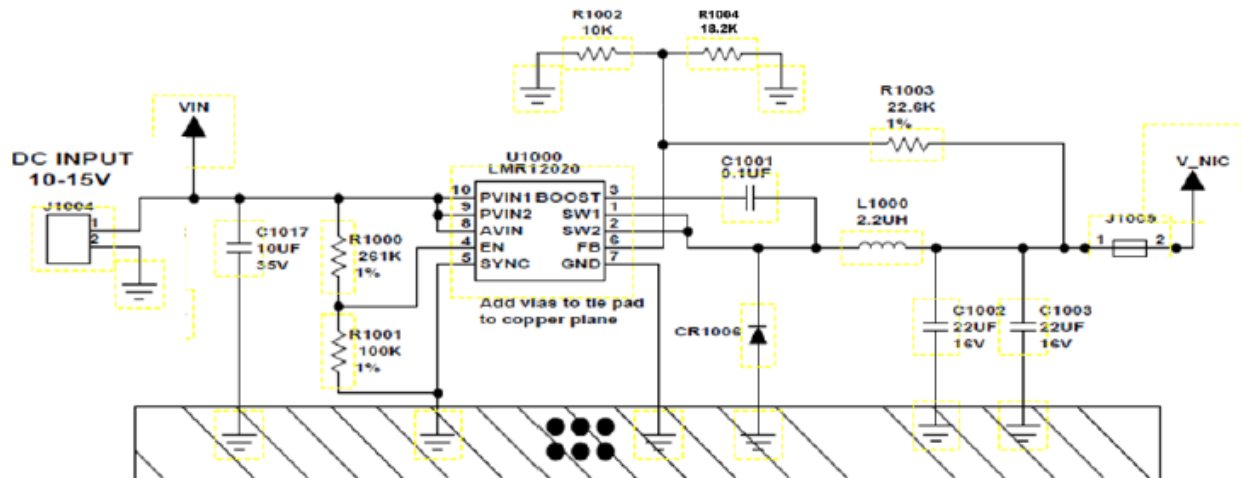

## 5.0 REGULATORY AND RF OUTPUT POWER REQUIREMENTS

### 5.1 Technical Assistance

Factory technical assistance is available by contacting GE MDS during business hours (8:30 AM to 6:00 PM Eastern Time). Use one of the following means to contact the factory:

Telephone: (585) 241-5510

FAX: (585) 242-8369

E-mail: [gemds.techsupport@ge.com](mailto:gemds.techsupport@ge.com)

Web: [www.gemds.com](http://www.gemds.com)

## 5.2 Regulatory Information, LW700 Module

### FCC Part 15 Notice

This Equipment has been tested and found to comply with the limits for a Class A digital device, pursuant to Part 15 of the FCC Rules. These limits are designed to provide reasonable protection against harmful interference when the equipment is operated in a commercial environment. This equipment generates, uses, and can radiate radio frequency energy and, if not installed and used in accordance with the instruction manual, may cause harmful interference to radio communications. Operation of this equipment in a residential area is likely to cause harmful interference in which case users will be required to correct the interference at their own expense.

This device complies with Part 15 of the FCC Rules. Operation is subject to the following two conditions: (1) this device may not cause harmful interference, and (2) this device must accept any interference received; including interference that may cause undesired operation.

**Warning:** *Changes or modifications not expressly approved by the manufacturer could void the user's authority to operate the equipment*

### Servicing Precautions

When servicing energized equipment, be sure to wear appropriate Personal Protective Equipment (PPE). During internal service, situations could arise where objects accidentally contact or short circuit components and the appropriate PPE would alleviate or decrease the severity of potential injury. When servicing radios, all workplace regulations and other applicable standards for live electrical work should be followed to ensure personal safety.

### Manual Revision and Accuracy

This manual was prepared to cover a specific version of firmware code. Accordingly, some screens and features may differ from the actual unit you are working with. While every reasonable effort has been made to ensure the accuracy of this publication, product improvements may also result in minor differences between the manual and the product shipped to you. If you have additional questions or need an exact specification for a product, please contact GE MDS, using the information provided in section 5.1 Technical Assistance above.

### Environmental Information

The manufacture of this equipment has required the extraction and use of natural resources. Improper disposal may contaminate the environment and present a health risk due to hazardous substances contained within. To avoid dissemination of these substances into our environment and to limit the demand on natural resources, we encourage you to use the appropriate recycling systems for disposal. These systems will reuse or recycle most of the materials found in this equipment in a sound way. Please contact GE MDS or your supplier for more information on the proper disposal of this equipment.

### Product Test Data Sheets

Test Data Sheets showing the original factory test results for this unit are available upon request from the GE MDS Quality Leader. Contact the factory using the information at the back of this manual. Serial numbers must be provided for each product where a Test Data Sheet is required.

### Grounding Requirements

To minimize the chance of damage to the unit and connected equipment, a safety ground (NEC Class 2 compliant) is recommended which bonds the antenna system, chassis, power supply and connected data equipment to a *single-point* ground, keeping all ground leads as short as possible. Normally, the unit is adequately grounded if the supplied mounting brackets are used to mount it to a well-grounded metal surface. If the unit is not mounted to a grounded surface, it is recommended that a safety ground wire be attached to one of the mounting brackets or a screw on the enclosure. The use of a lightning protector is recommended where the antenna cable enters the building. Bond the protector to the tower/support ground, if possible.

All grounds and cabling must comply with applicable codes and regulations.

## FCC Limited Modular Approval Notice

This device is offered as an FCC Licensed *Limited Modular Transmitter (LMA)*. Applicable rule parts include Part 15 and Part 27. The transmitter module is approved for use only with specific antenna, cable and output power configurations that have been tested and approved for use when installed in devices approved by third-party OEMs, or produced by the Grantee (GE MDS). Modifications to the radio, the antenna system, or power output, that have not been explicitly specified by the manufacturer are not permitted, and may render the radio non-compliant with applicable regulatory authorities. When this module is placed inside an enclosure, a durable label must be affixed to the outside of the final host device and shall be labeled with “**Contains FCC ID: E5MDS-LW700**” indicating the module’s FCC ID Numbers.

**Note:** A host product is required to comply with all applicable FCC equipment authorizations regulations and/or requirements and equipment functions not associated with the transmitter module portion. For example requirements for any co-location of additional transmitter with the module and/or at the minimum compliance with FCC part 15B & IC ICES-003; Digital device are the sole responsibility of the OEM integrators for the final host device.

## RF Exposure Warnings

The antenna(s) to be used with this module must be installed with consideration to the guidelines for RF exposure risk to all nearby personnel, and must not be co-located or operating in conjunction with any other antenna or transmitter.



Concentrated energy from a directional antenna may pose a health hazard to humans. Do not allow people to come closer to the antenna than the distances listed in the table below when the transmitter is operating.

	Antenna Gain *		
	0-5 dBi	5-10 dBi	10-16.5 dBi
<b>Safety Distance LW700</b>	<b>0.23 meters</b>	<b>0.41 meters</b>	<b>0.86 meters</b>

\* Values are based on 30.2 dBm using an RMS detector at 757.0MHz, using 100% duty cycle. Note that these values include margin for acceptable tolerance and are extremely conservative. QAM modulation peak-to-average ratio and duty cycle due to media access control ensure that this limit is never reached in a real customer-accessible operating mode.

Calculations are as per FCC KDB 447498 D01 and Section 2.1091, with General Public Uncontrolled Exposure Limits defined in Section 1.1310

Antennas with gain greater than 16.5 dBi have not been authorized for this device. Installation of the device into portable applications is not authorized.

### 5.3 RF Output Settings

Consult Table 3 for the applicable power settings. The LW700 is a multi-modem system operating between 757-758MHz and 787-788MHz, in channel bandwidths of 195kHz, 315kHz, and 570kHz. OFDM modulation choices in each bandwidth include QPSK and 16QAM variants. OTA Rate and maximum power is based on the modem choice and the applicable emission mask for the operating frequency. The RF output is not to exceed 30.2dBm average power as a function of the 30dBm +/-0.2dBm calibration tolerance.

	MCS	Option 2	Option 3	Option 4	Maximum Output Power (Band Power)	Comments
DFT size		64	32	16		
Active Tones		52	26	14		
Pilot Tones		4	4	2		
Data Tones		48	24	12		
		<b>PSDU data rates [kb/s]</b>				
<b>QPSK, rate 1/2, 2X repetition</b>	<b>2</b>	200	100	50	<b>30 dBm</b>	
<b>QPSK, rate 1/2</b>	<b>3</b>	400	200	100	<b>30 dBm</b>	
<b>QPSK, rate 3/4</b>	<b>4</b>	600	300	150	<b>30 dBm</b>	
<b>16QAM, rate 1/2</b>	<b>5</b>	800	400	200	<b>30 dBm</b>	
<b>16QAM, Rate 3/4</b>	<b>6</b>	1200	600	300	<b>30 dBm</b>	

Table 3. LW700 Power Output

### 5.4 Offered Antennas

Consult Table 4 for offered antennas.

Part#	Description
97-3194A35	ANTENNA, OMNI 746-869MHz 3dB N-F
97-3194A38	ANTENNA, LOW PROFILE OMNI 698-960MHz 1710-2700MHz 3dB NO GROUND PLANE, VANDAL-PROOF N-FEMALE
97-3194A36	ANTENNA, YAGI 745-806MHz 7 Element 10dBd 2' COAX N-F
97-3194A37	ANTENNA, PANEL 698-960MHz 6.5dBi N-F
97-3194A39	ANTENNA, PANEL 696-900MHz, 63deg BEAM, 12.5dBd, 0deg TILT, 7/16 EDIN FEMALE, with Mounting Hardware
97-3194A40	ANTENNA, PANEL 696-900MHz, 120deg BEAM, 13.5dBd, 0deg TILT, 7/16 EDIN FEMALE, with Mounting Hardware

Table 4. LW700 offered antennas

### 5.5 Center Frequency Channel Limits

Consult Table 5 for Center Frequency Channel Limits based on the modem Option selected. The tuning resolution of the LW700 is in 1.25kHz increments allowing any combination of channels within the following licensed 757 to 758 and 787 to 788MHz band segments for regulatory compliance.

MODEM Option	Lower Min Frequency (MHz)	Lower Max Frequency (MHz)	Upper Min Frequency (MHz)	Upper Min Frequency (MHz)
2 (570kHz BW)	757.500	757.500	787.500	787.500
3 (315kHz BW)	757.245	757.755	787.245	787.755
4 (195kHz BW)	757.170	757.830	787.170	787.830

Table 5. LW700 Center Frequency Channel Limits