

AZ91H18E2C/AZ91H18E3C/AZ91H18E5C

GE Zoneline® Heat Pump Single Package

Vertical Air Conditioner, 265 Volt

DIMENSIONS AND INSTALLATION INFORMATION (IN INCHES)

MINIMUM CLEARANCES:

FRONT

- Allow 4 inches in front of unit. Note that plenum may protrude into closet, depending on exterior wall thickness.

SIDES

- Allow 3 inches on each side of unit.

OPTIONAL PLATFORM

- Field-supplied, refer to installation instructions.

- Platform height must coordinate with the height of the thru wall plenum.

SIDE-ACCESS CLOSETS

- Not recommended for new installations.

265 VOLT	AZ91H18E2C	AZ91H18E3C	AZ91H18E5C
Heater KW	2.5	3.4	5
Min. Circuit Amps	15	20	30
Recommended Protective Device	15 Amp Time Delay Fuse or Breaker	20 Amp Time Delay Fuse or Breaker	30 Amp Time Delay Fuse or Breaker

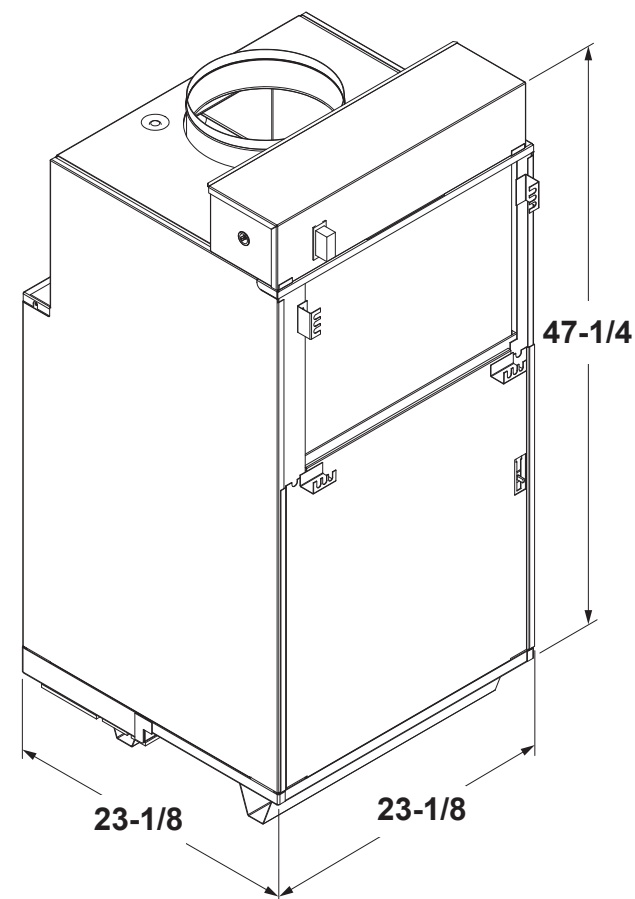

For answers to your Monogram, GE Café™ Series, GE Profile™ Series or GE Appliances product questions, visit our website at geappliances.com or call GE Answer Center® Service, 800.626.2000.

Specification Revised 12/16

AZ91H18E2C/AZ91H18E3C/AZ91H18E5C

GE Zoneline® Heat Pump Single Package

Vertical Air Conditioner, 265 Volt

FEATURES AND BENEFITS

Cooling capacity - 18,000 BTU

Vertical space-saving design - Optimizes usable floor space

Reliable & quiet - Every component is engineered to provide exceptional performance

Corrosion treatment on outside coils

Model AZ91H18E2C - 15 amp

Model AZ91H18E3C - 20 amp

Model AZ91H18E5C - 30 amp

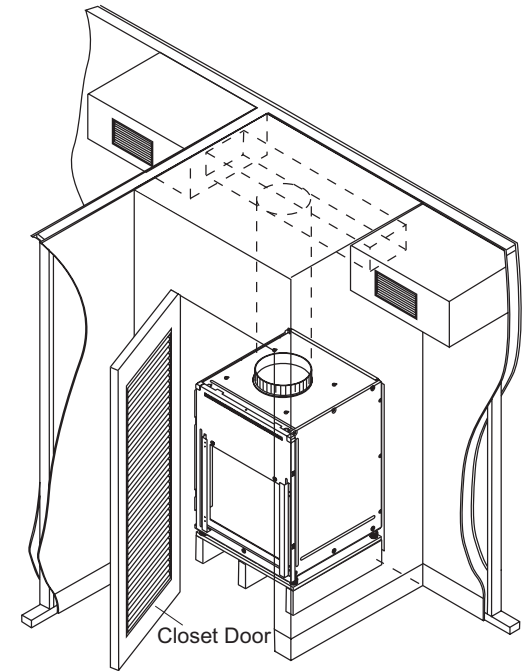

ZONELINE® WARRANTY*

WHAT IS COVERED

LIMITED ONE-YEAR WARRANTY

For one year from date of original purchase, we will provide, free of charge, parts and service labor on site to repair or replace any part of the Zoneline that fails because of a manufacturing defect.

LIMITED ADDITIONAL FOUR-YEAR WARRANTY

For an additional four years from the date of original purchase, we will provide, free of charge, parts and on-site service labor to repair or replace any part of the sealed refrigerating system (the compressor, condenser, evaporator and all connecting tubing) that fails because of a manufacturing defect.

*SEE WRITTEN WARRANTY FOR DETAILS

LIMITED 2ND THROUGH 5TH YEAR PARTS WARRANTY

For the second through the fifth year from date of original purchase, General Electric will provide, free of charge, parts that fail as a result of a manufacturing defect. Parts covered are fan motors, switches, heater, heater protectors, compressor overload, solenoids, circuit boards, auxiliary controls, thermistors, frost controls, capacitors and varistors. This is a limited parts-only warranty, and does not include labor or transportation to and from the service shop.

All warranty service will be provided by our Factory Service Centers or by our authorized Customer Care® servicers during normal working hours.



For answers to your Monogram, GE Café™ Series, GE Profile™ Series or GE Appliances product questions, visit our website at geappliances.com or call GE Answer Center® Service, 800.626.2000.