

EXPERIMENT MANUAL

REMOTE-CONTROL MACHINES FARM



THAMES & KOSMOS



920381-03-xxxx18

Fränkisch-Kosmos Verlagsgesellschaft & Co. KG, Pflanzstr. 5-7, 70184 Stuttgart, Germany | +49 (0) 711 2191-0 | www.kosmos.de
Thames & Kosmos, 301 Friendship St., Providence, RI, 02903, USA | +1-800-587-2872 | www.thamesandkosmos.com
Thames & Kosmos UK LP, 20 Stone Street, Cranbrook, Kent, TN17 3HE, UK | 01580 713000 | www.thamesandkosmos.co.uk

SAFETY INFORMATION

Safety Information

Warning! Not suitable for children under 3 years. Choking hazard — small parts may be swallowed or inhaled. Store the experiment material and assembled models out of the reach of small children. The models are intended for indoor use. Do not use your models in a sandbox. Keep packaging and instructions as they contain important information.

Safety for Experiments with Batteries

- >>> The wires are not to be inserted into socket-outlets. Never perform experiments using household current! The high voltage can be extremely dangerous or fatal!
- >>> To operate the models, you will need eight AA batteries (1.5-volt, type AA/LR6), which could not be included in the kit due to their limited shelf life.
- >>> The supply terminals are not to be short-circuited. A short circuit can cause the wires to overheat and the batteries to explode.
- >>> Different types of batteries or new and used batteries are not to be mixed.
- >>> Do not mix old and new batteries.
- >>> Do not mix alkaline, standard (carbon-zinc), or rechargeable (nickel-cadmium) batteries.
- >>> Batteries are to be inserted with the correct polarity. Press them gently into the battery compartments. See page 2.
- >>> Always close battery compartments with the lid.
- >>> Non-rechargeable batteries are not to be recharged. They could explode!
- >>> Rechargeable batteries are only to be charged under adult supervision.
- >>> Rechargeable batteries are to be removed from the toy before being charged.
- >>> Exhausted batteries are to be removed from the toy.
- >>> Dispose of used batteries in accordance with environmental provisions, not in the household trash.
- >>> Be sure not to bring batteries into contact with coins, keys, or other metal objects.
- >>> Avoid deforming the batteries.
- >>> As all of the experiments use batteries, have an adult check the experiments or models before use to make sure they are assembled properly. Always operate the motorized models under adult supervision. After you are done experimenting, remove the batteries from the battery compartments. Note the safety information accompanying the individual experiments or models!

Notes on Disposal of Electrical and Electronic Components

The electronic components of this product are recyclable. For the sake of the environment, do not throw them into the household trash at the end of their lifespan. They must be delivered to a collection location for electronic waste, as indicated by the following symbol:



Please contact your local authorities for the appropriate disposal location.

Dear Parents and Supervising Adults,

Before starting the experiments, read through the instruction manual together with your child and discuss the safety information. Check to make sure the models have been assembled correctly, and assist your child with the experiments.

We hope you and your child have a lot of fun with the experiments!

FCC Part 15 Statement

This device complies with Part 15 of the FCC Rules. Operation is subject to the following two conditions: (1) This device may not cause harmful interference, and (2) this device must accept any interference received, including interference that may cause undesired operation.

FCC warning: Changes or modifications not expressly approved by the party responsible for compliance could void the user's authority to operate the equipment.

Note for PC car with receiver: This equipment complies with FCC radiation exposure limits set forth for an uncontrolled environment and meets the FCC radio frequency (RF) Exposure Guidelines. This equipment has very low levels of RF energy that it deemed to comply without maximum permissive exposure evaluation (MPE). But it is desirable that it should be installed and operated keeping the radiator at least 20cm or more away from person's body.

Note for hand-held RC unit: This equipment complies with FCC radiation exposure limits set forth for an uncontrolled environment and meets the FCC radio frequency (RF) Exposure Guidelines. This equipment has very low levels of RF energy that are deemed to comply without testing of specific absorption ratio (SAR).

IC Statement

This device complies with Industry Canada's license-exempt RSSS. Operation is subject to the following two conditions:

- (1) This device may not cause interference; and
- (2) This device must accept any interference, including interference that may cause undesired operation of the device.

Son fonctionnement est soumis aux deux conditions suivantes:

- (1) Cet appareil ne peut pas provoquer d'interférences et
- (2) Cet appareil doit accepter toute interférence, y compris les interférences qui peuvent causer un mauvais fonctionnement du dispositif.

This device complies with the SED radiation exposure limit set forth for an uncontrolled environment. This device should be installed and operated with minimum distance 20cm between the radiator and your body. This transmitter must not be co-located or operating in conjunction with any other antenna or transmitter.

Cet équipement est conforme avec l'exposition aux radiations (SED) définies pour un environnement non contrôlé. Cet équipement doit être installé à une distance minimum de 20 cm entre le radiateur et votre corps. Cet émetteur ne doit pas être co-localisé ou opérant en conjonction avec une autre antenne ou transmetteur.



Kosmos Quality and Safety

More than one hundred years of expertise in publishing science experiment kits stand behind every product that bears the Kosmos name. Kosmos experiment kits are designed by an experienced team of specialists and tested with the utmost care during development and production. With regard to product safety, these experiment kits follow European and US safety standards, as well as our own refined proprietary safety guidelines. By working closely with our manufacturing partners and safety testing labs, we are able to control all stages of production. While the majority of our products are made in Germany, all of our products, regardless of origin, follow the same rigid quality standards.

1st Edition 2018:Thames & Kosmos, LLC, Providence, RI, USA
Thames & Kosmos® is a registered trademark of Thames & Kosmos, LLC

This work, including all its parts, is copyright protected. Any use outside the specific limits of the copyright law without the consent of the publisher is prohibited and punishable by law. This applies specifically to reproduction, translation, microfilming, and storage and processing in electronic systems and networks. We do not guarantee that all material in this work is free from copyright or other protection.

Technical product development: Genius Toy, Taiwan Co., Ltd., Taichung, Taiwan, R.O.C.

Author: Camille Duhamel

Manual Layout: Camille Duhamel and Mark Geary

Editing: Ted McGuire

Additional Graphics and Packaging: Don Freitas

Manual design concept: Alexander Bae Klerck, Berlin

Manual (Illustrations: Genius Toy, Taiwan Co., Ltd., Taichung, Taiwan, R.O.C., and Thames & Kosmos

Manual photos: casage (all paper clips), Jamie Dupress (all tape strips), pacific (all push pins), p. 12 (compass) Thiele; (all previous © fdeola.com).

Photo: Alexander Miliac, p. 64 (middle left) (combine with red header 34cmx1179, p. 50 (top) (GPS) "A", p. 50 (bottom) (iron) ektas1919, p. 64 (top right) (blue old tractor) Jenny Thompson, p. 64 (middle left) (insect gear SEM image) University of Cambridge (prof. Malcolm Burrows & Gregory Sutton), (CC BY-SA 3.0), p. 22 (middle) (three pink hitch) hth, (CC BY-SA 3.0), p. 22 (bottom) (power takeoff shaft) hth, (CC BY-SA 3.0), p. 26 (reeder) Moutain (Public Domain), p. 31 (windmill) Daniel Pizanesi (Doplaan), (CC BY-SA 2.5), p. 31 (insect) Fritz Geiler-Grimm (CC BY-SA 2.5), p. 31 (bottom) (insect gear SEM image) University of Cambridge (prof. Malcolm Burrows & Gregory Sutton), (CC BY-SA 3.0), p. 50 (top) (grain and chaff image) National Plant Germplasm System (USDA/ARS) (Public Domain), (all previous: Wikipedia).

All remaining images: Thames & Kosmos, Francis&Taylor.com, GmBH & Co. KG, and Genius Toy, Taiwan Co., Ltd.

The publisher has made every effort to locate the holders of image rights for all of the photos used. If in any individual cases only holders of image rights have not been acknowledged, they are asked to provide evidence to the publisher of their image rights so that they may be paid an image fee in line with the industry standard.

Distributed in North America by: Thames & Kosmos, LLC, Providence, RI 02903

Phone: 800-587-8372; Web: www.thamesandkosmos.com

Distributed in United Kingdom by: Thames & Kosmos UK LP, Cranbrook, Kent TN17 3HE

Phone: 01580 713000; Web: www.thamesandkosmos.co.uk

We reserve the right to make technical changes.

Printed in Taiwan / Imprimé en Taiwan

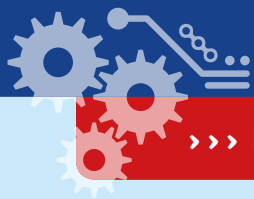

>>> KIT CONTENTS

GOOD TO KNOW! If you are missing any parts, please contact Thames & Kosmos customer service.
 US: techsupport@thamesandkosmos.com
 UK: techsupport@thamesandkosmos.co.uk

What's inside your experiment kit:

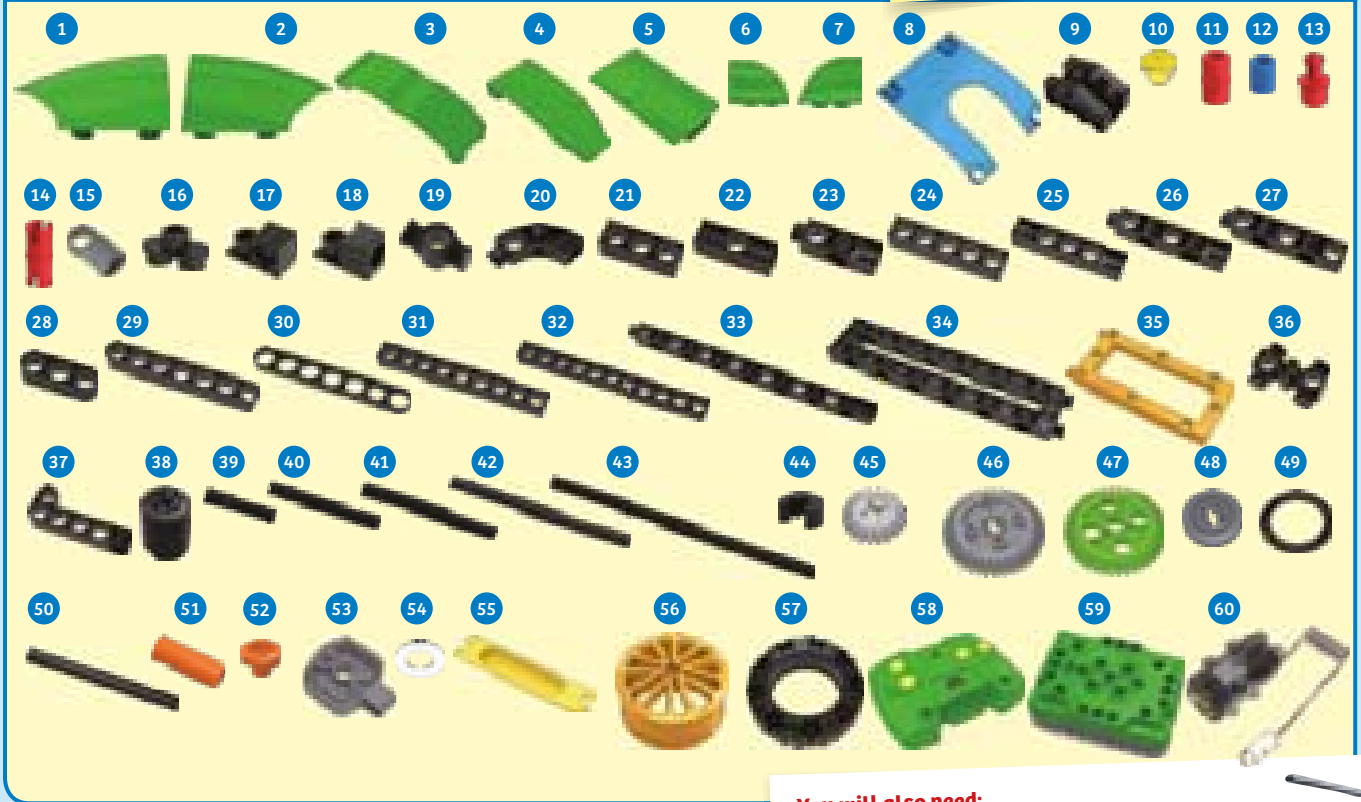

You will also need:

8 x AA batteries (1.5-volt, type AA/LR6), and a small Phillips-head screwdriver to open the battery compartment

Checklist: Find – Inspect – Check off

✓	No.	Description	Qty.	Item No.
<input type="checkbox"/>	1	Body plate left, green	1	7392-W10-L1
<input type="checkbox"/>	2	Body plate right, green	1	7392-W10-L2
<input type="checkbox"/>	3	Large body plate	3	7398-W10-C1
<input type="checkbox"/>	4	Large body plate B	3	7398-W10-C2
<input type="checkbox"/>	5	Flat body plate	2	7407-W10-D1
<input type="checkbox"/>	6	Small body plate C, right	2	7407-W10-D2
<input type="checkbox"/>	7	Small body plate C, left	2	7407-W10-D3
<input type="checkbox"/>	8	U-shaped body plate	1	7396-W10-I1B
<input type="checkbox"/>	9	Gripper	1	7411-W10-G1D
<input type="checkbox"/>	10	Button pin	8	7061-W10-W1TY
<input type="checkbox"/>	11	Anchor pin, red	10	7061-W10-C1R
<input type="checkbox"/>	12	Short anchor pin, blue	100	7344-W10-C2B
<input type="checkbox"/>	13	Shaft plug	1	7026-W10-H1R
<input type="checkbox"/>	14	Joint pin	8	1156-W10-A1R
<input type="checkbox"/>	15	Axle rod connector	21	7410-W10-C1S
<input type="checkbox"/>	16	Two-to-one converter	2	7061-W10-G1D
<input type="checkbox"/>	17	90-degree converter X, black	4	7061-W10-X1D
<input type="checkbox"/>	18	90-degree converter Y, black	4	7061-W10-Y1D
<input type="checkbox"/>	19	1-hole connector	29	7430-W10-B1D
<input type="checkbox"/>	20	Curved rod	2	7061-W10-V1D
<input type="checkbox"/>	21	3-hole rod	1	7026-W10-Q2D
<input type="checkbox"/>	22	3-hole cross rod	6	7026-W10-X1D
<input type="checkbox"/>	23	3-hole dual rod	6	7413-W10-Y1D
<input type="checkbox"/>	24	5-hole rod	2	7413-W10-K2D
<input type="checkbox"/>	25	5-hole cross rod	1	7413-W10-R1D
<input type="checkbox"/>	26	5-hole dual rod C, black	2	7413-W10-X1D
<input type="checkbox"/>	27	5-hole dual rod B, black	3	7413-W10-W1D
<input type="checkbox"/>	28	3-hole wide rounded rod	5	7404-W10-C1D
<input type="checkbox"/>	29	7-hole wide rounded rod	5	7404-W10-C2D
<input type="checkbox"/>	30	7-hole flat rounded rod	5	7404-W10-C3D

✓	No.	Description	Qty.	Item No.
<input type="checkbox"/>	31	9-hole rod	5	7407-W10-C1D
<input type="checkbox"/>	32	11-hole rod	8	7413-W10-P1D
<input type="checkbox"/>	33	15-hole dual rod	2	7413-W10-Z1D
<input type="checkbox"/>	34	3x13 dual frame	2	7406-W10-A1D
<input type="checkbox"/>	35	Rounded short frame	1	7411-W10-E1 ()
<input type="checkbox"/>	36	3-hole bolt rod, black	9	7406-W10-B1D
<input type="checkbox"/>	37	5-hole L rod	9	7406-W10-B2D
<input type="checkbox"/>	38	Worm gear	2	7344-W10-A1D
<input type="checkbox"/>	39	35-mm axle	4	7413-W10-O1D
<input type="checkbox"/>	40	60-mm axle	5	7413-W10-M1D
<input type="checkbox"/>	41	70-mm axle	6	7061-W10-Q1D
<input type="checkbox"/>	42	100-mm axle	9	7413-W10-L2D
<input type="checkbox"/>	43	150-mm axle	1	7026-W10-P1D
<input type="checkbox"/>	44	Axle lock	2	3620-W10-A1D
<input type="checkbox"/>	45	Small gear, gray	12	7026-W10-D2S
<input type="checkbox"/>	46	Medium gear, gray	7	7346-W10-C1S
<input type="checkbox"/>	47	Medium gear, green	5	7408-W10-D1G
<input type="checkbox"/>	48	Pulley wheel, small	1	7344-W10-N3S1
<input type="checkbox"/>	49	Rubber O-ring	1	R12-08S
<input type="checkbox"/>	50	70-mm tube	2	7337-W16-A1D
<input type="checkbox"/>	51	Tube bolt	2	7404-W10-G10
<input type="checkbox"/>	52	Tube bolt cap	2	7404-W10-G20
<input type="checkbox"/>	53	Flange	2	7398-W10-E1S
<input type="checkbox"/>	54	Washer	3	R12#3620
<input type="checkbox"/>	55	Anchor pin lever	1	7061-W10-B1Y
<input type="checkbox"/>	56	Wheel	4	7407-W10-B1Y
<input type="checkbox"/>	57	Tire	4	7408-W10-C1D
<input type="checkbox"/>	58	4-channel remote control unit	1	7447-W85-A
<input type="checkbox"/>	59	RC Receiver	1	7447-W85-B
<input type="checkbox"/>	60	Motor (35x Motor)	2	7447-W85-C

>>> TIPS AND TRICKS

Here are a few tips for assembling and using the models. Read them carefully before starting.

A. Place the tires on the wheels

Place a tire over each of the four wheels before you build the first model.

B. Batteries in RF remote control unit

Open the battery compartment by pushing on the tab on the back of the RF receiver unit and lifting the back panel up. Insert two AA batteries, paying attention to the polarity indicated in the compartment and on the batteries. Close the compartment again.

C. Batteries in RF receiver

Open the battery compartment by pushing on the tab on the bottom of the RF battery box. Insert six AA batteries, paying attention to the polarity indicated in the compartment and on the batteries. Close the compartment again.

D. Using the RF remote control

To control a model, turn on both the motor unit and the remote control unit by moving their switches from the "off" position (O) to the "on" position (—). The lights will flash on the RF remote control unit and receiver while they establish a connection. Once a connection is established the lights on the receiver will turn off and the light on the remote control unit will be solid. If you are using multiple RF remote control units and battery boxes in the same area, set the remote control units to different channels and then establish connections to the battery.

The left side of the RC unit controls the socket on the left side of the battery box. The right side of the RC unit controls the socket on the right side of the battery box.

If you want your model to move in the opposite direction when you press one of the RC unit buttons, you can simply rotate the direction of the plug in the socket 180 degrees.

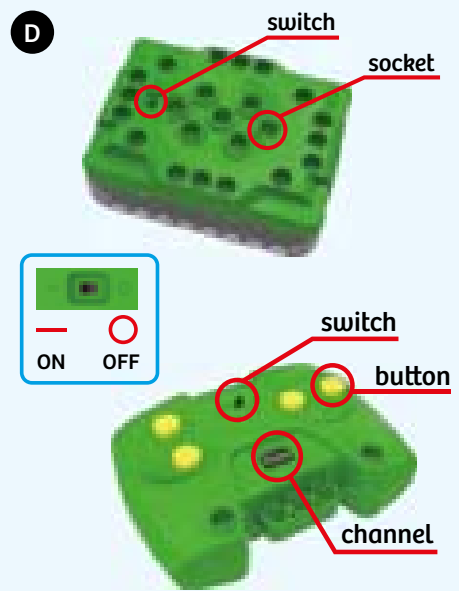
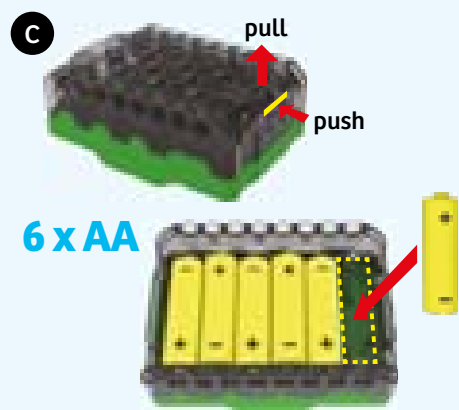
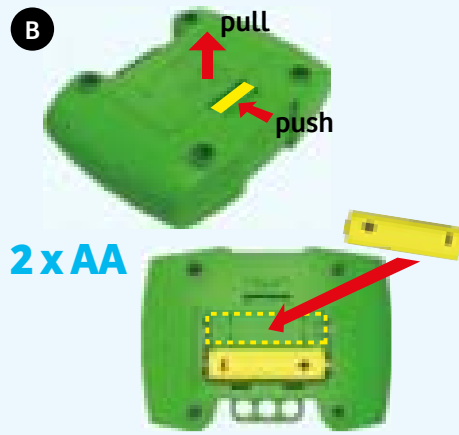
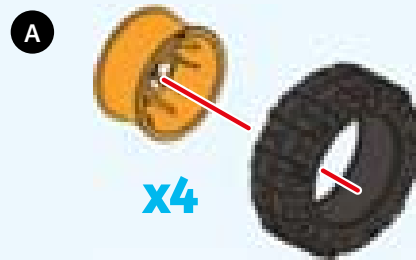

GENERAL BUILDING TIPS

ANCHOR PINS AND CONNECTORS



Take a careful look at the different assembly components. Red anchor pins, blue anchor pins, joint pins, and shaft plugs all look pretty similar at first glance. When you assemble the models, it's important to use the right ones. The blue anchor pins are shorter than the red ones.

CONNECTING FRAMES AND RODS

Use the anchor pins to connect frames and rods.



AXLES

The building system contains axles (also called shafts) of various lengths. When assembling the model, always be sure that you're using the right one.



ANCHOR PIN LEVER

When you want to take your model apart again, you will need the anchor pin lever. Use the narrow end of the lever to remove the anchor pins. You can use the wide end to pry out shaft plugs.



PULLEYS AND GEARS

If pulleys or gears are mounted too tightly against other components, they can be hard to turn. If you leave a gap of about 1 mm between the gear or pulley and an adjacent component, it will turn easily. In some of the models, a washer is used to ensure this kind of spacing. (There are no gears included in this kit.)

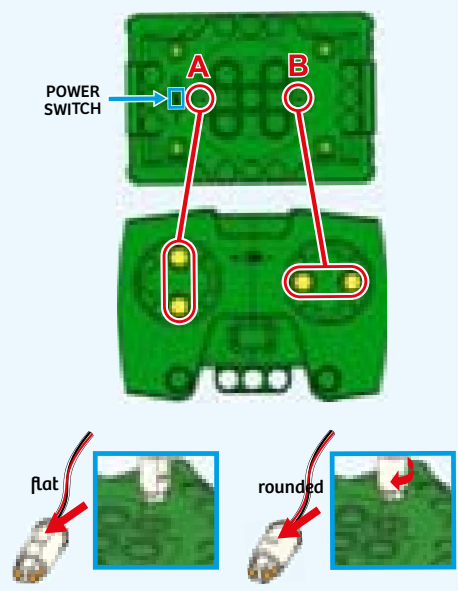

>>> TABLE OF CONTENTS

TIP!

You will find additional information in the "Check it out" sections on pages 14, 18, 22, 26, 31, 50, 57, and 64.



Safety Information Inside front cover

Kit Contents..... 1
Tips and Tricks 2
Table of Contents..... 3

Introduction

Agriculture and Agricultural Engineering 4

Tractors..... 5

In this section build a tractor and four different attachments for the tractor. You will also learn about how each attachment works and their importance in farming.

The models:

Tractor 5
Disc Harrow15
Cultivator19
Seeder 23
Hay Rake27

Combine Harvester 32

Build a combine harvester and learn how it is used on a farm to harvest crops.

The models:

Combine Harvester 32

Farm Truck 51

Build a farm truck which is used to move materials around a farm, and learn about how farmers are using remote sensing technology.

The models:

Farm Truck.....51

Windrower 58

Build a windrower and learn about how new technologies, such as drones, are being used on farms.

The models:

Windrower58

Publisher's Information Inside back cover

TIP!

Above each set of assembly instructions, you will find a red bar:

>>> It shows you the difficulty level for the model's assembly:



easy

medium

hard

Agriculture and Agricultural Engineering

Agriculture is the cultivation of crops or raising of animals for food or raw materials. To make farming task easier farmers use many different tools and specialized equipment. Currently, farmers are under increasing pressure to harvest as much as possible from their land due to climate change, population grown, and limited resources. To overcome these challenges farmers and agricultural engineers have developed new innovations and technology. In this kit, you will build some of these farm vehicles and learn about how they function.



● ● ● TRACTOR

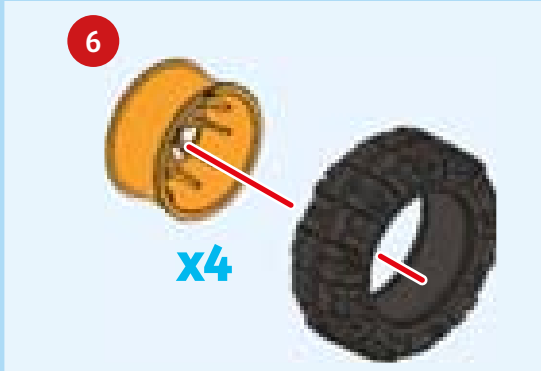
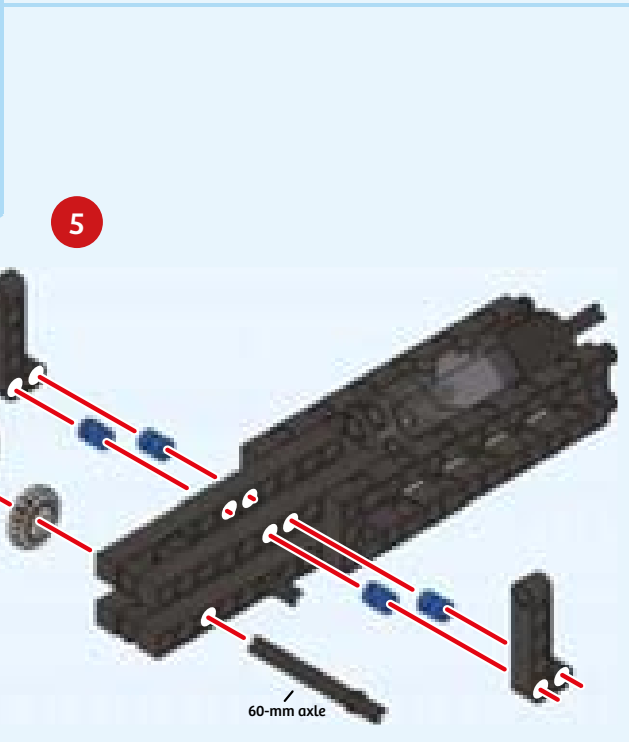
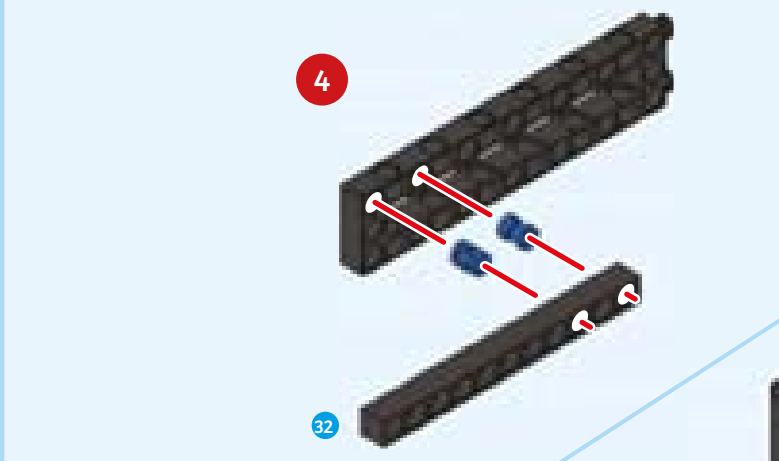
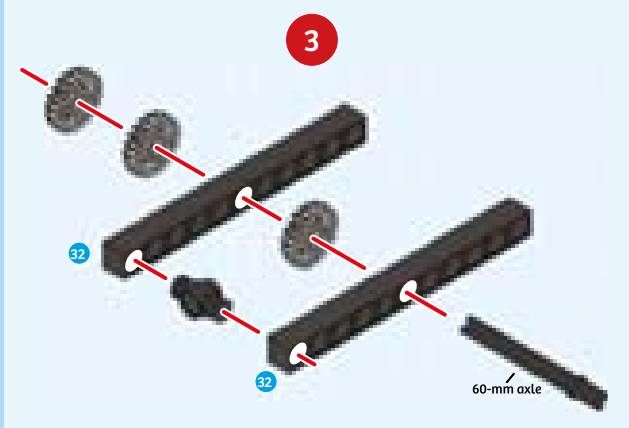
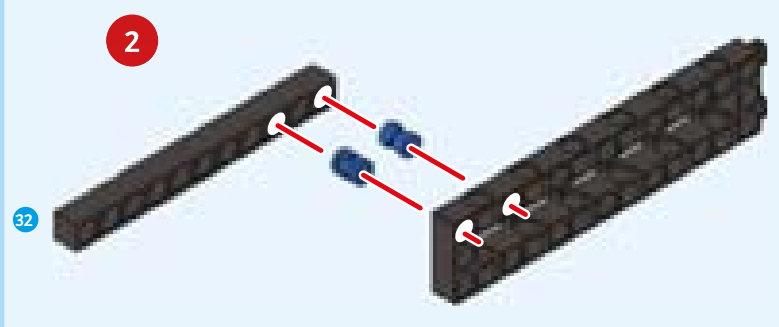
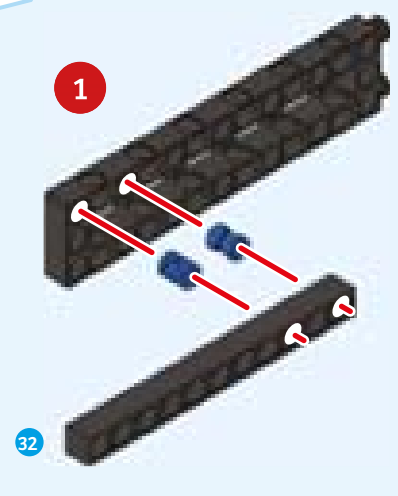
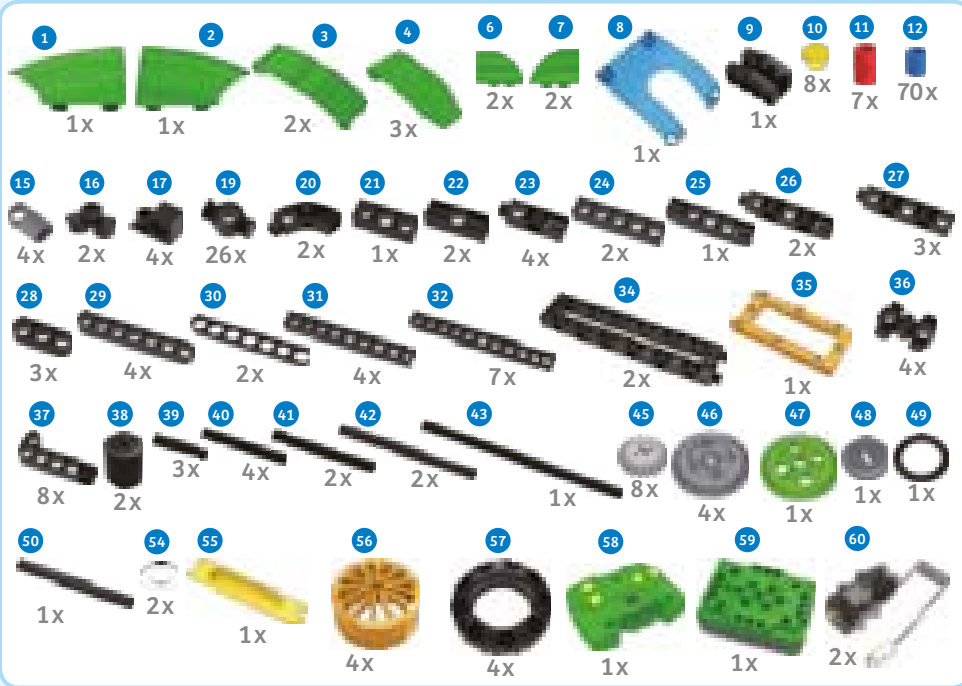



TRACTOR

7

x2

27

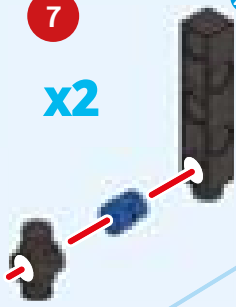

8

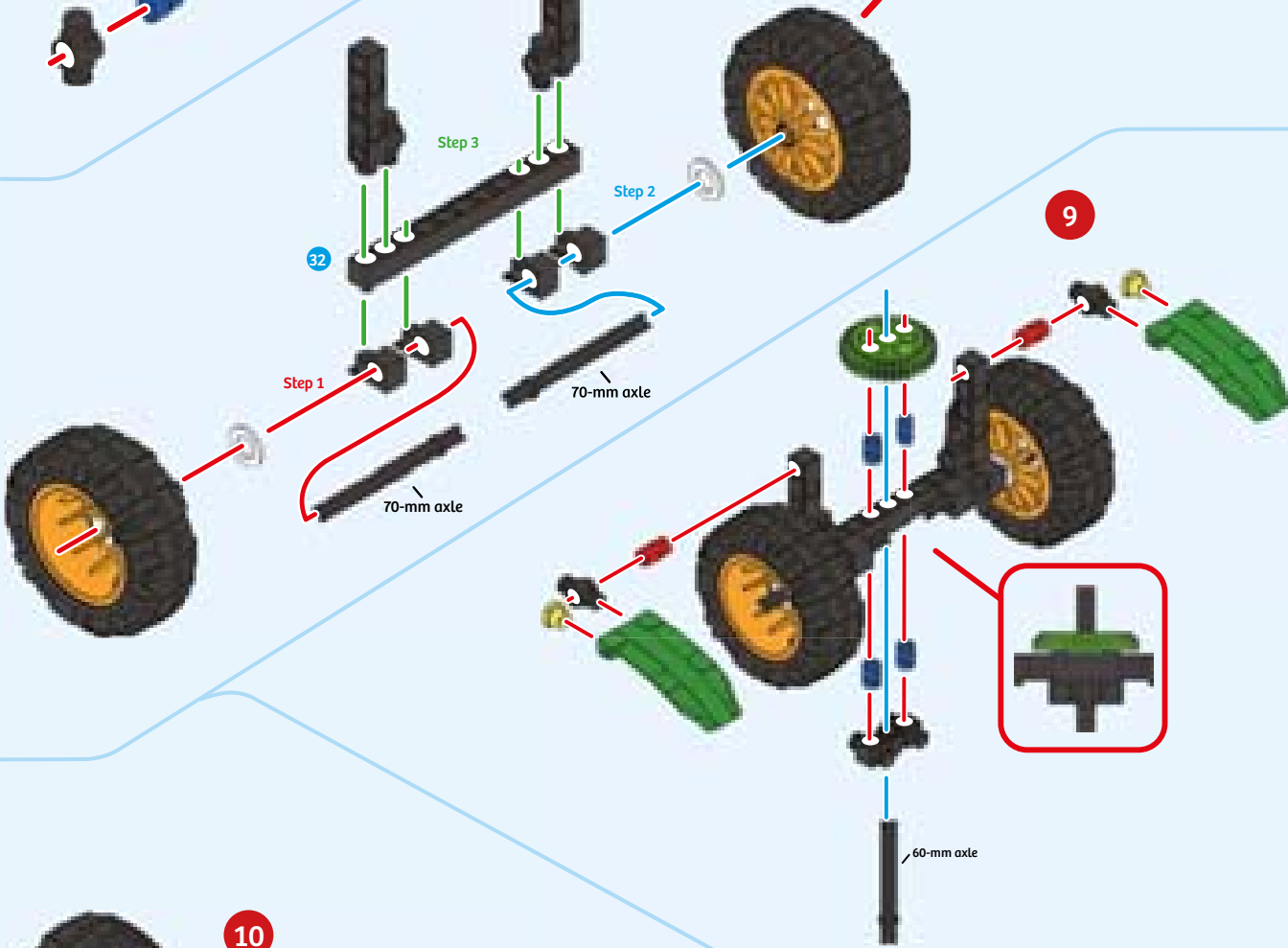
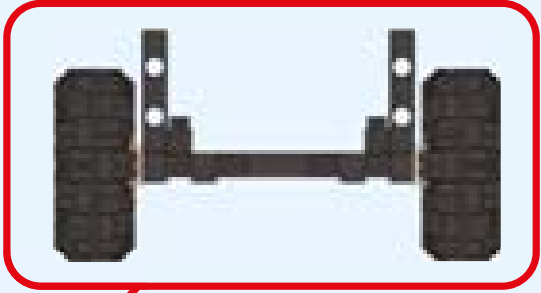

10

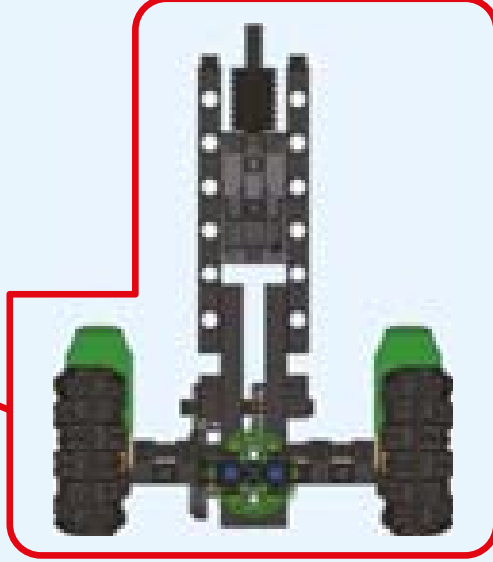
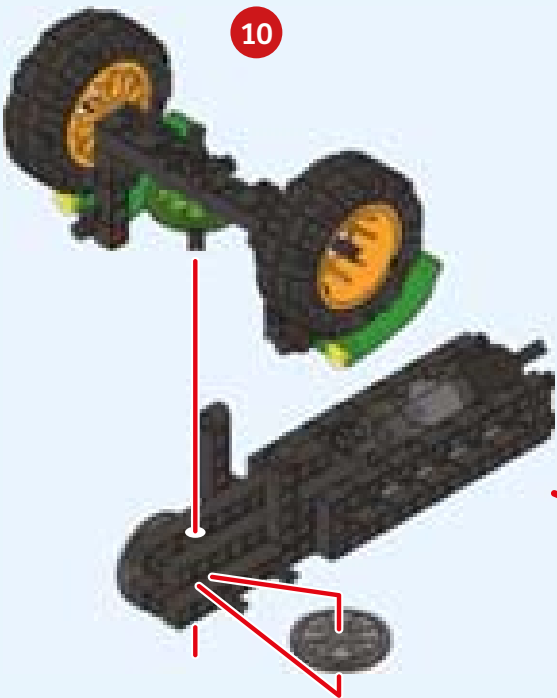

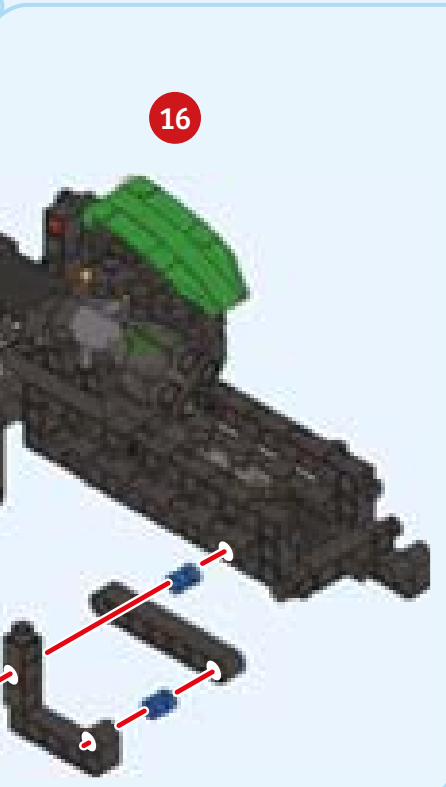
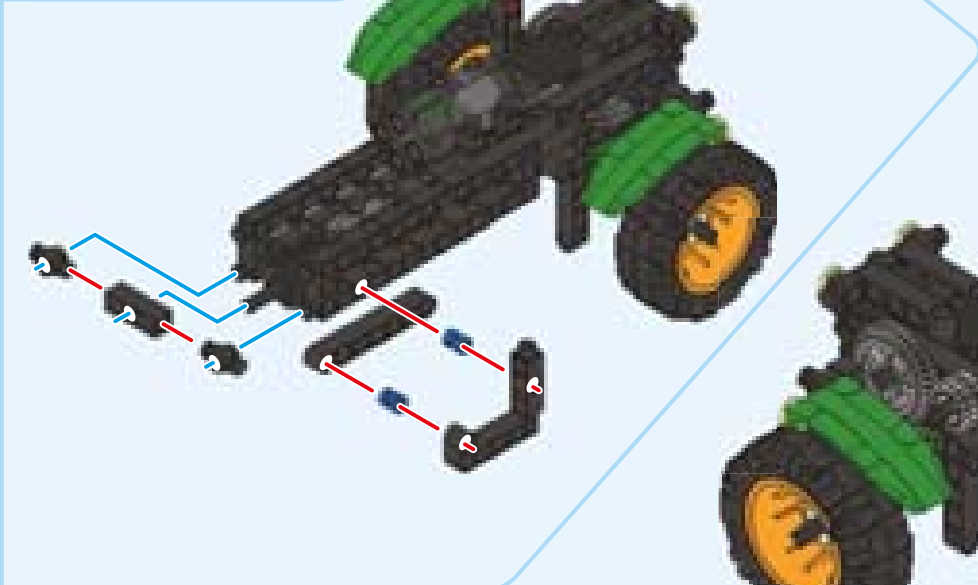
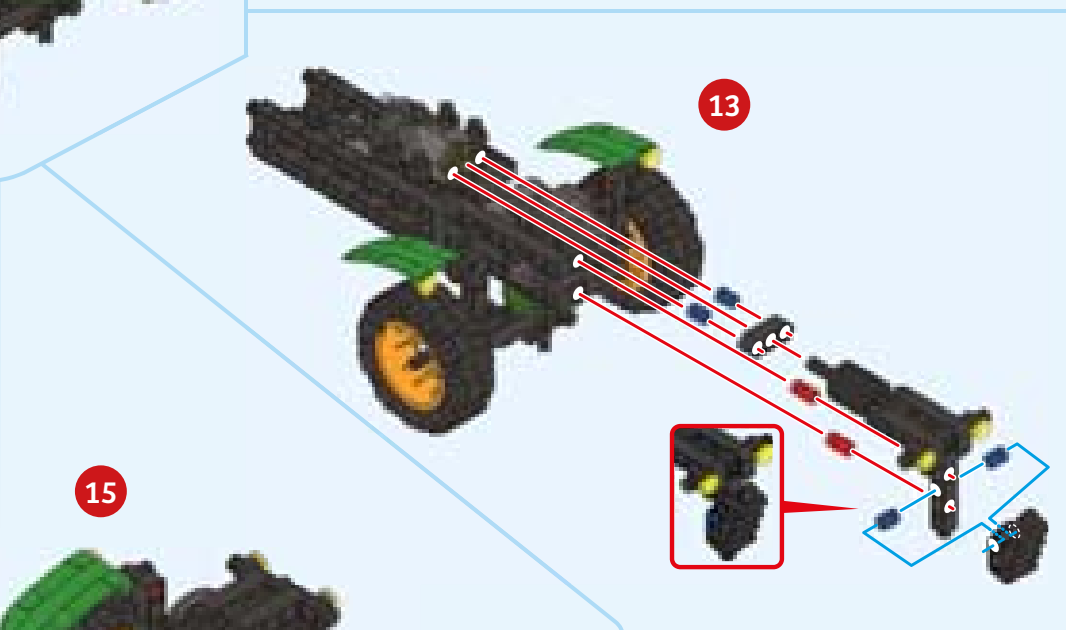
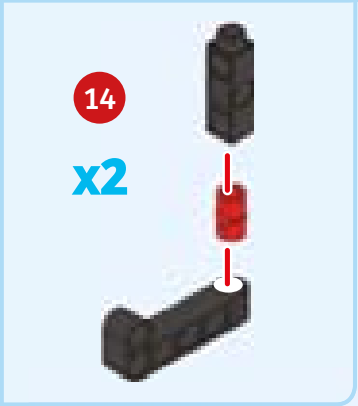
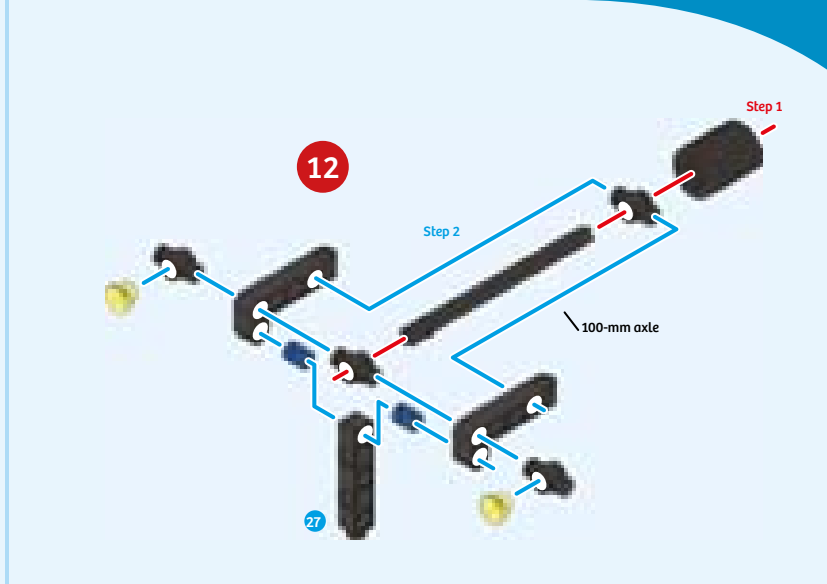
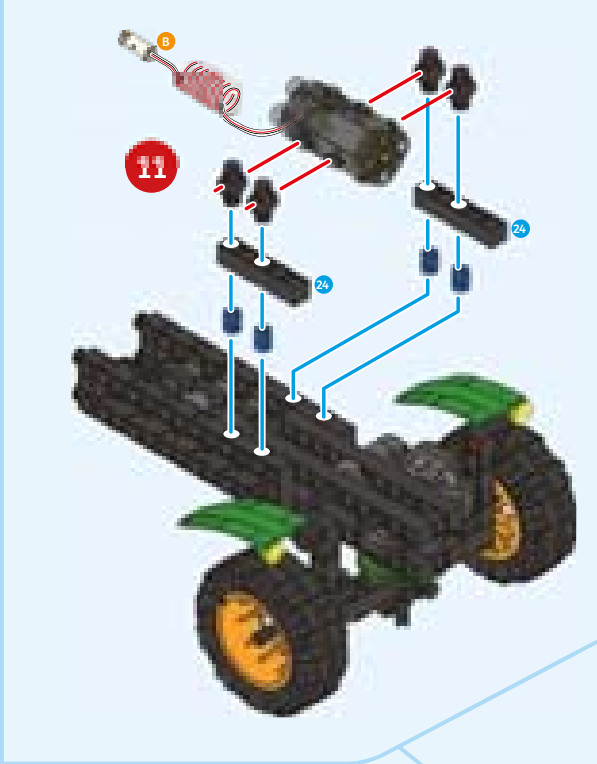



TRACTOR

17

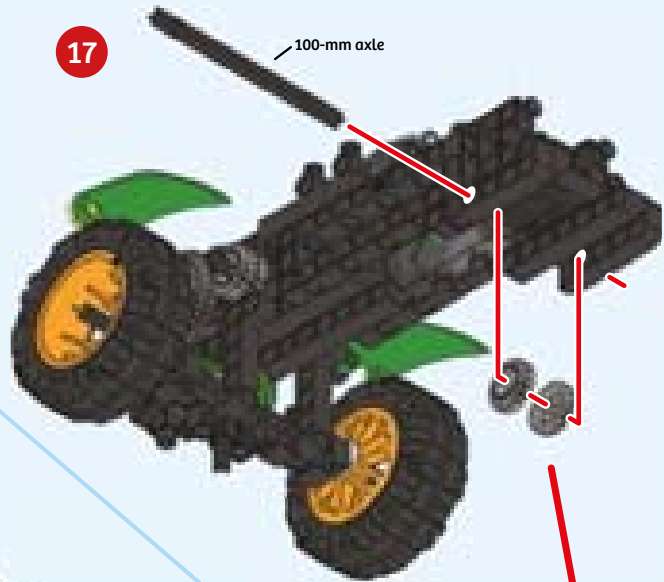

100-mm axle

18

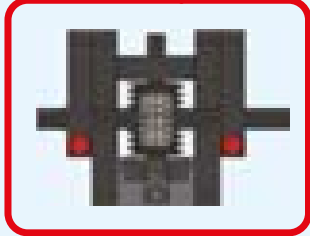

19

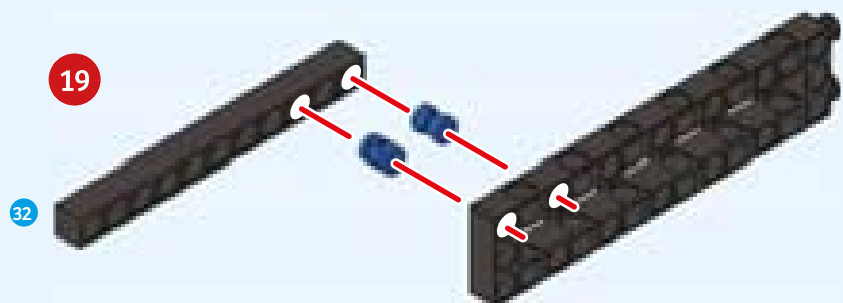

32

20

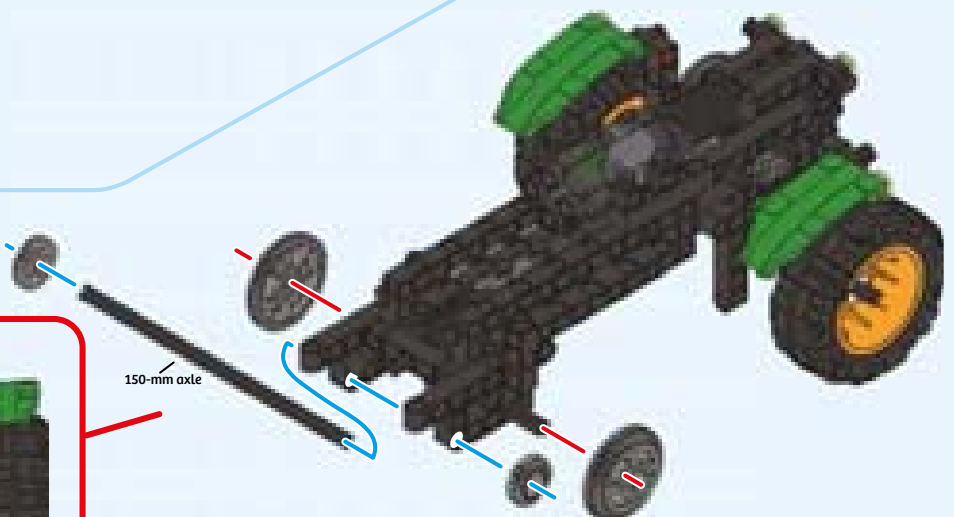

150-mm axle

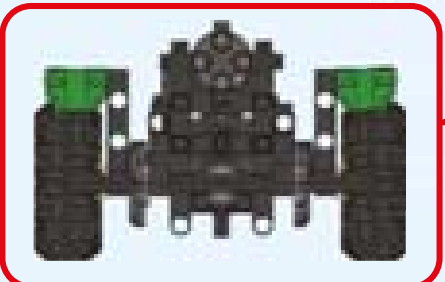

21

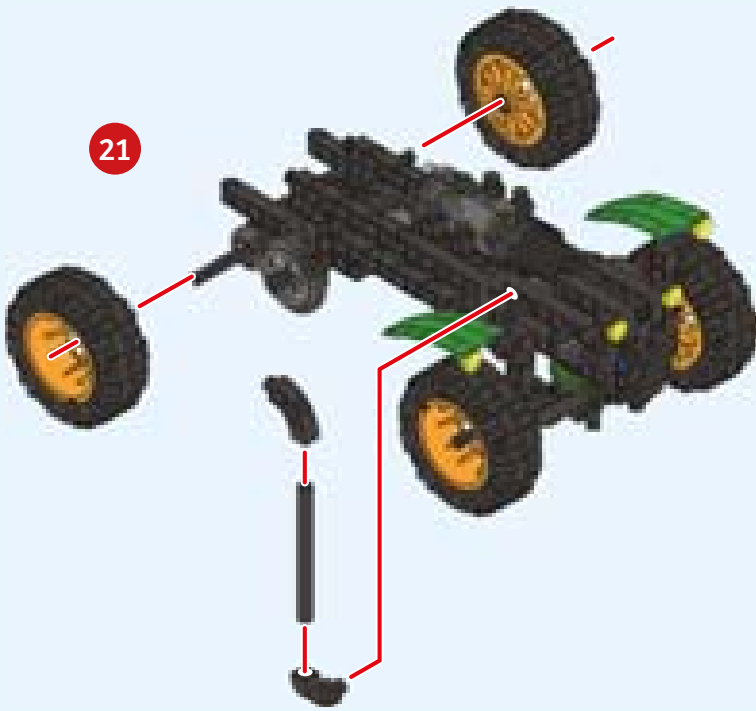

22

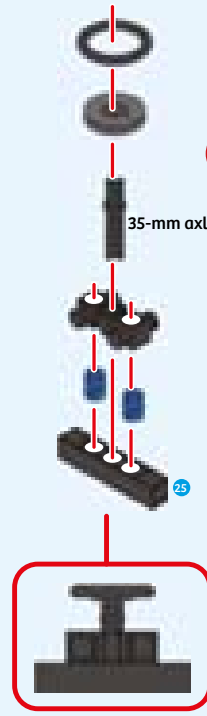

23

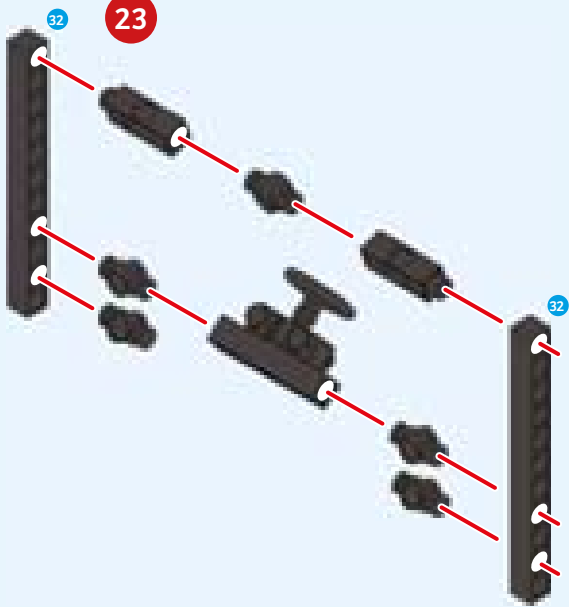

24

pass the blue part through before step 3

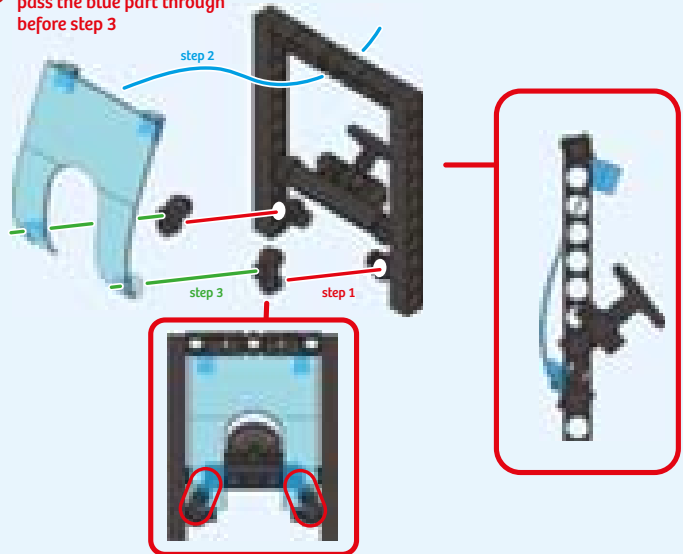

25

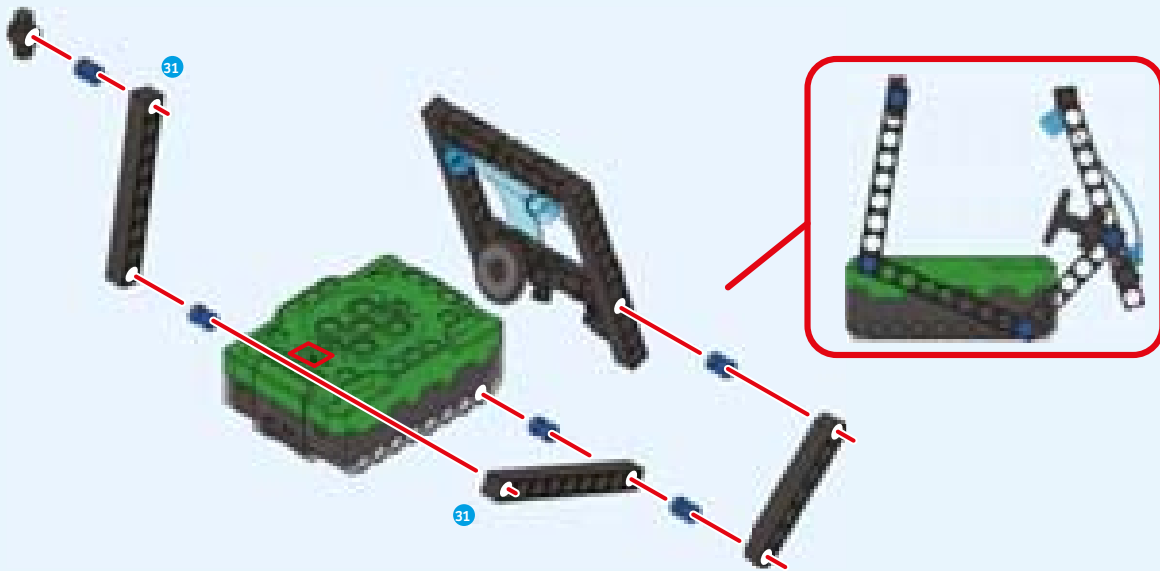



TRACTOR

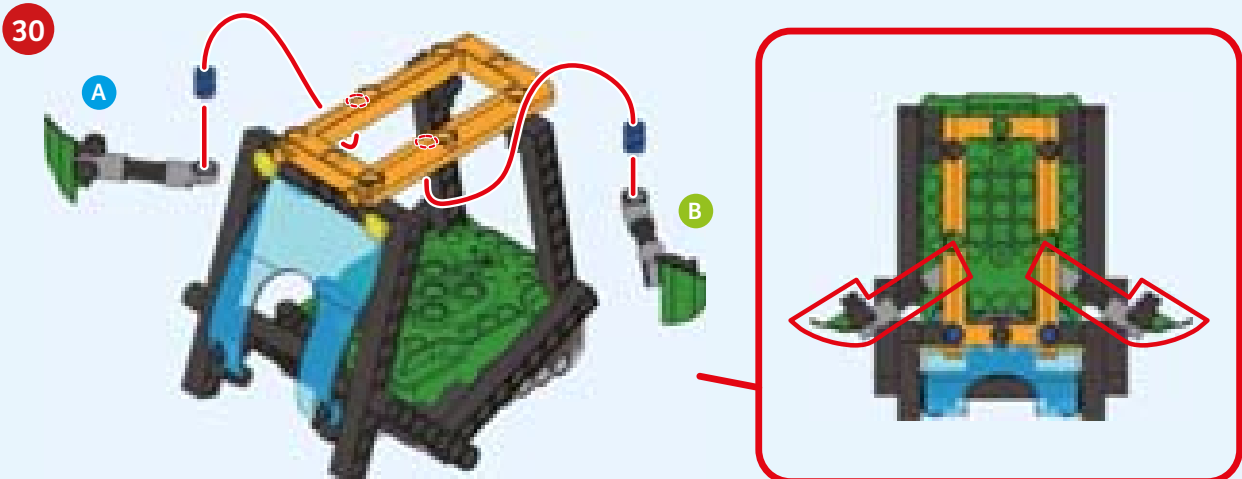
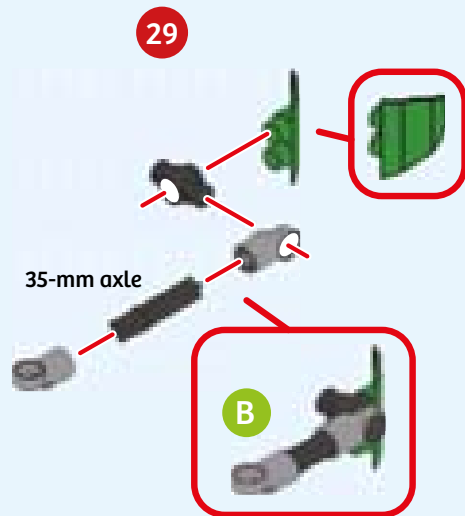
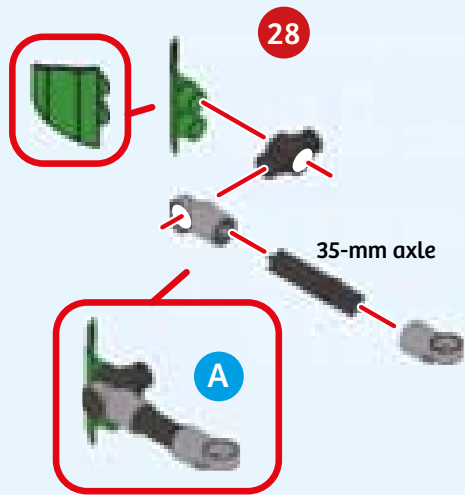
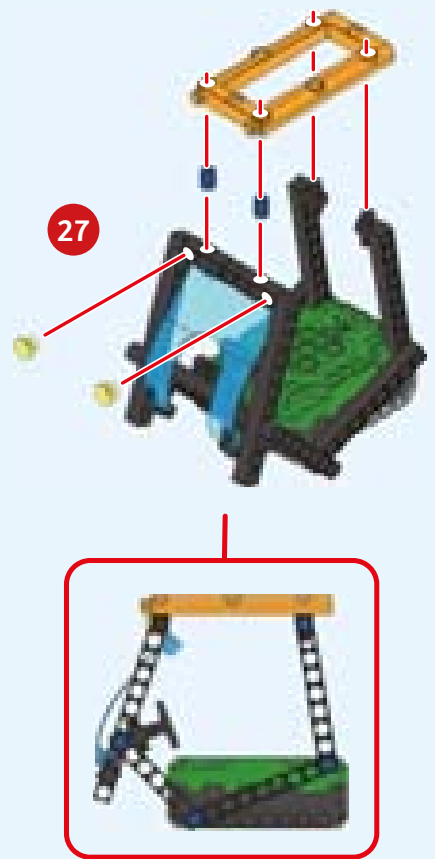
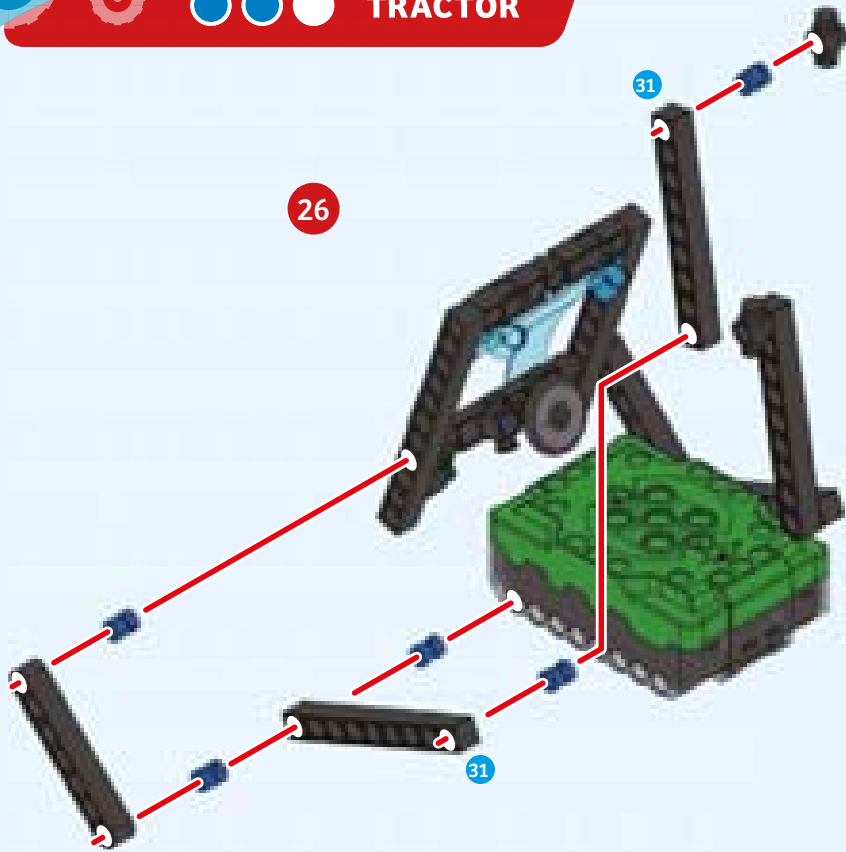

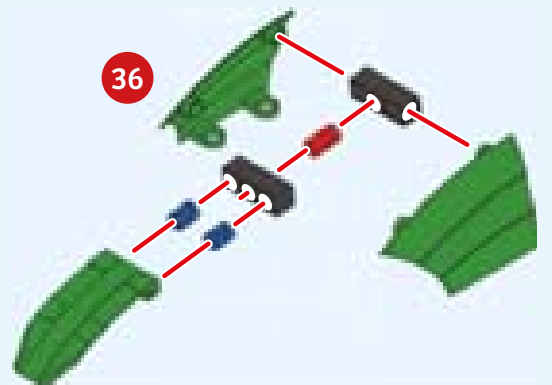
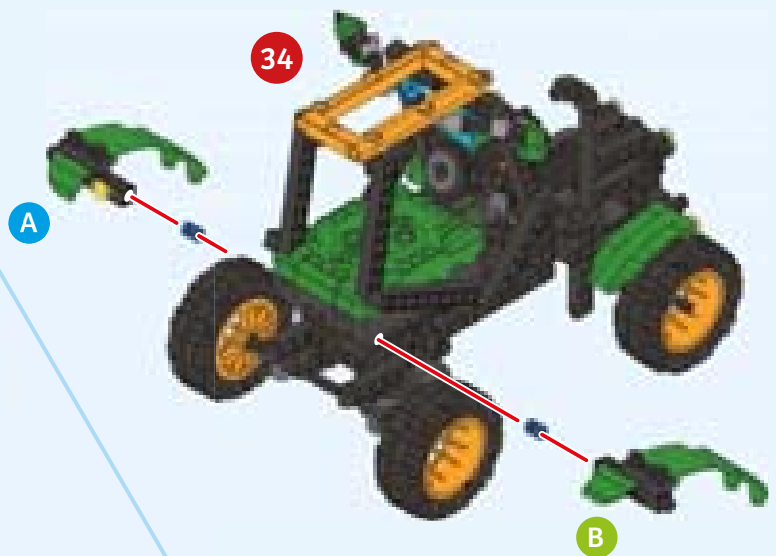
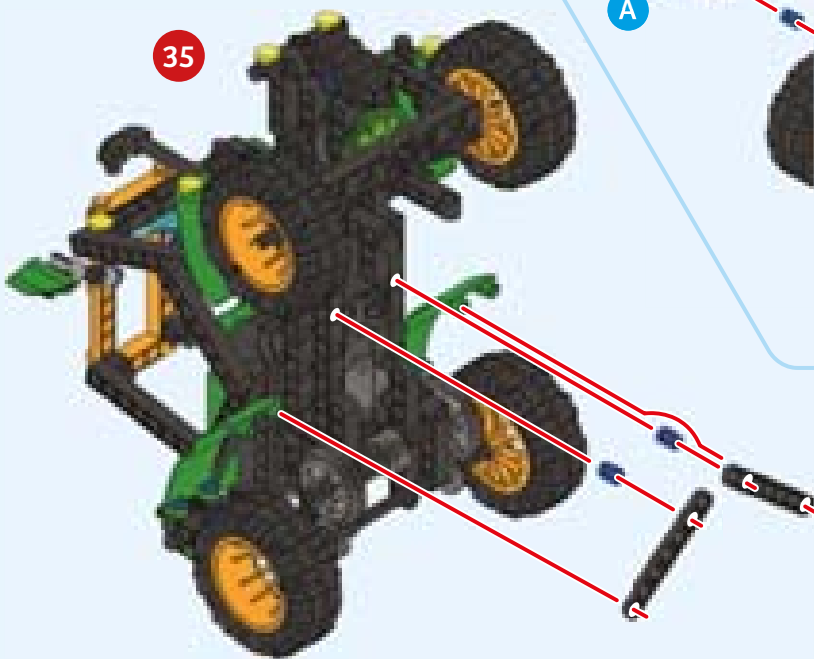
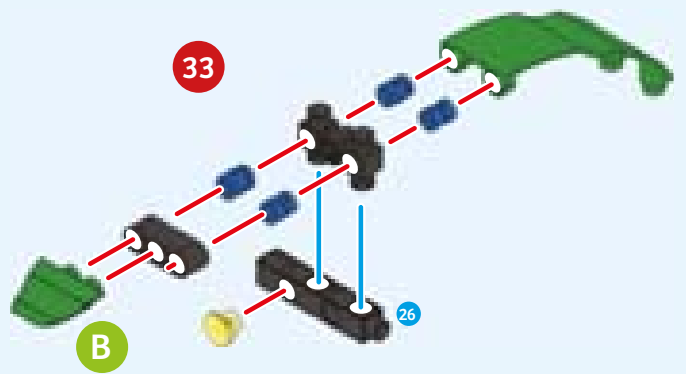
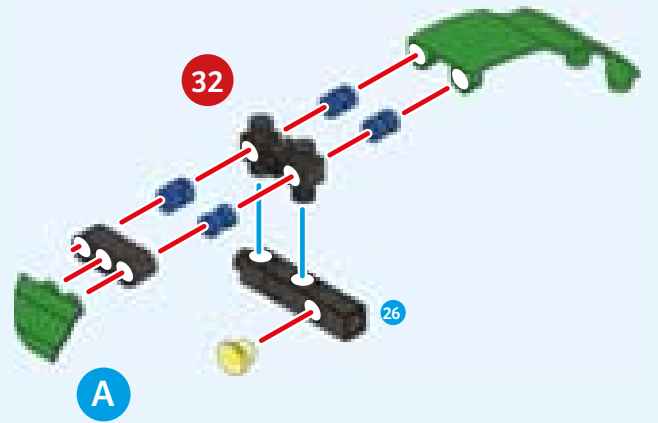
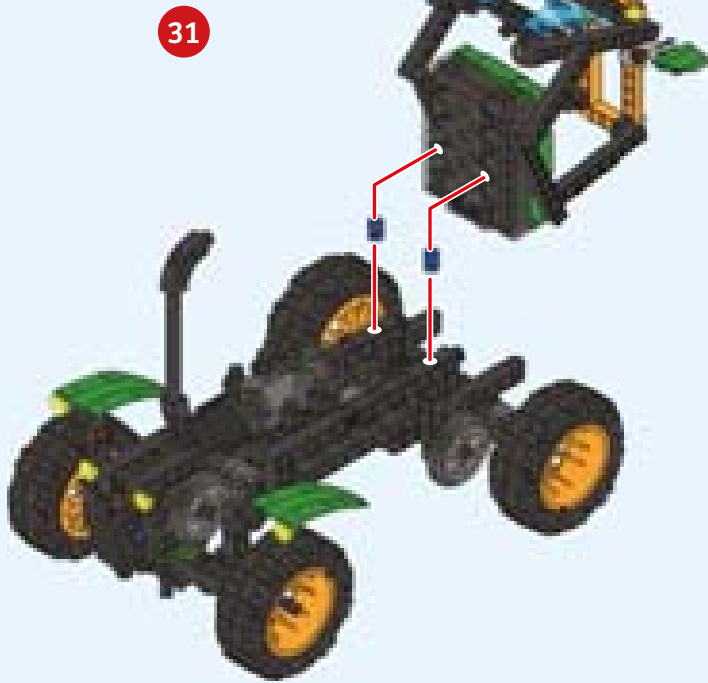

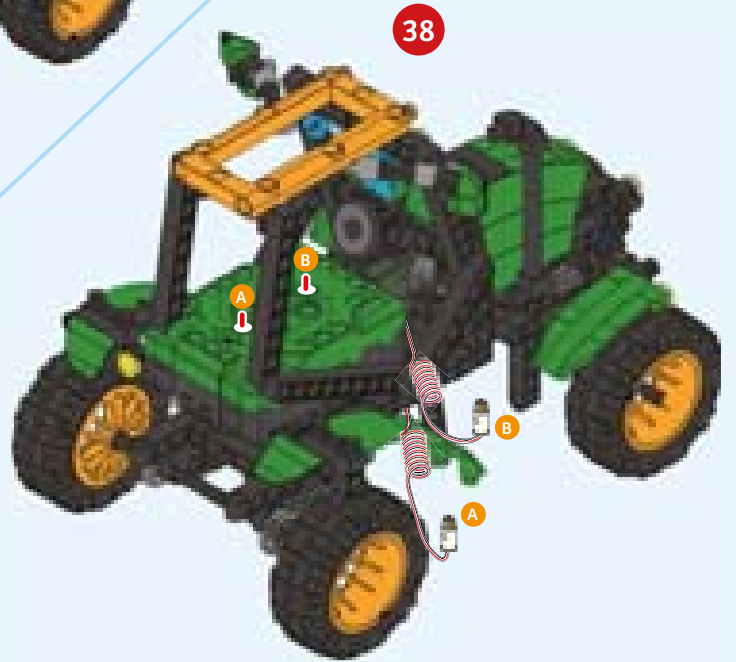
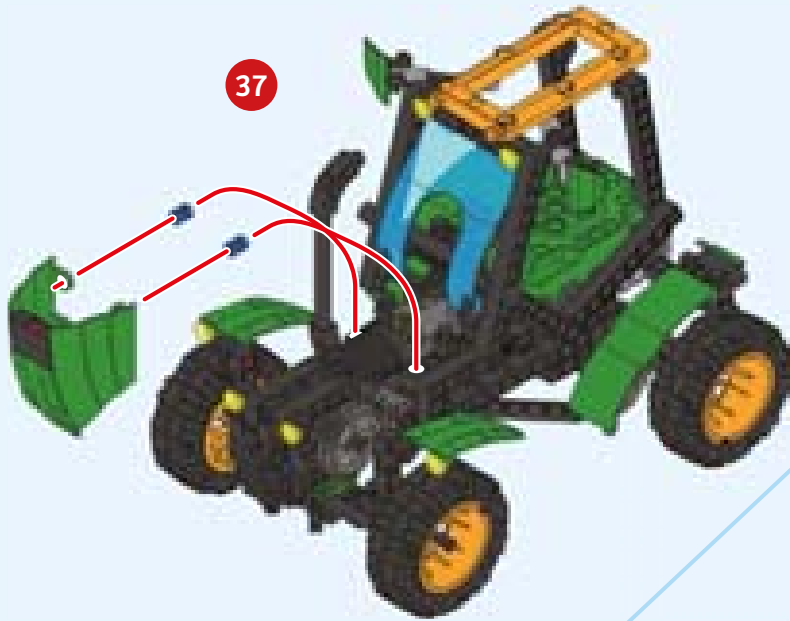

EXPERIMENT 1

Speeding up and slowing down?

HERE'S HOW

Measure a set distance on your floor, for example two feet. Use a stop watch to measure the amount of time that it takes the tractor to travel this set distance. Then use the instructions on page 13 to change the gear ratio of the tractor. Repeat the previous experiment with modified tractor. What happens to the time it takes for the travel this distance?



1

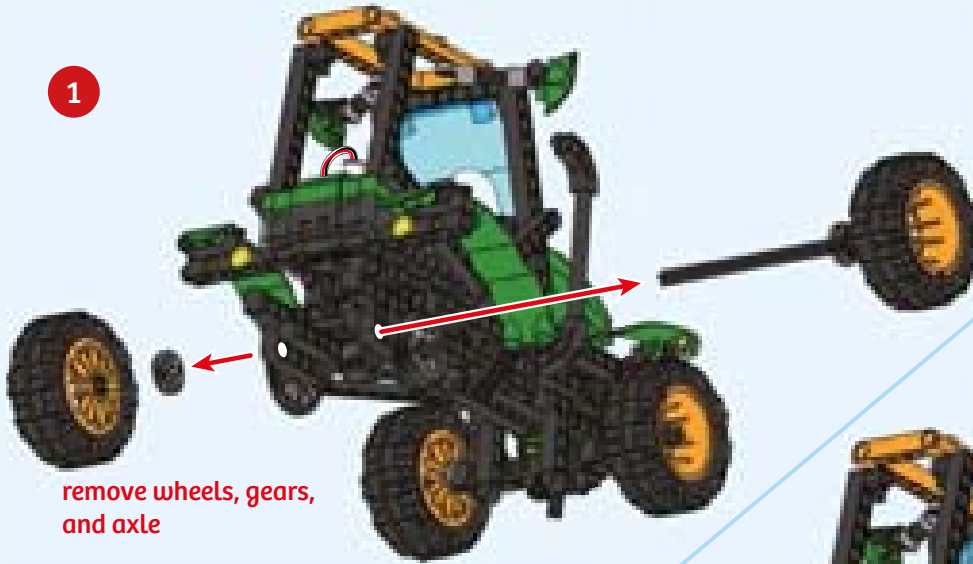

remove wheels, gears, and axle

2



remove gears and axle

3



replace axle, gears, and wheels

#45 x2

4



Done!



Engines

How do tractors produce enough traction to pull large pieces of machinery through different conditions, such as muddy or sandy soil?

The ability of a tractor to perform work comes from the engine. The type of engine used in tractors and cars are called heat engines, because they convert thermal energy, or the energy from heat, into mechanical energy, or the energy of motion. Heat engines accomplish this by heating up a fluid, called the working fluid.

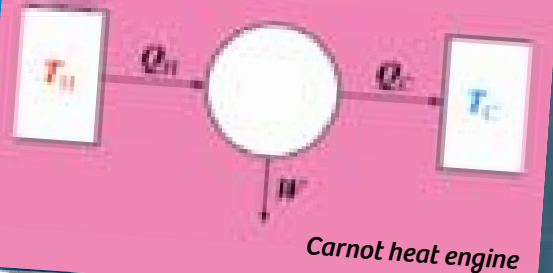

STEAM ENGINE

The first powered farm machines used **steam engines**. In a steam engine, the working fluid is water, which is heated until it is steam.

Water is made up of many very small water molecules. When water is heated the water molecules move around faster, take up more space, and bump into their container more increasing the pressure. The steam can then be put into a sealed container which has only one surface that can move up and down as the steam expands and contracts, turning the thermal energy of the steam into mechanical energy! This sealed container is called a **cylinder** in an engine and the part that moves up and down is called a **piston**.

Steam engines are **external combustion engines** because the steam is separate from what is used to heat the steam, such as burning coal.

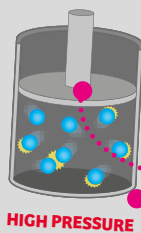
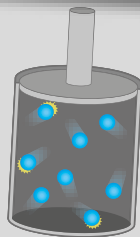

Now tractor engines use **internal combustion engines** that use a fossil fuel, usually gasoline or diesel. They are called that because fuel is ignited inside the cylinder and, just like the water in a steam engine, expands pushing on the piston. This causes the piston to turn the crankshaft which is used to turn the wheels of the tractor.

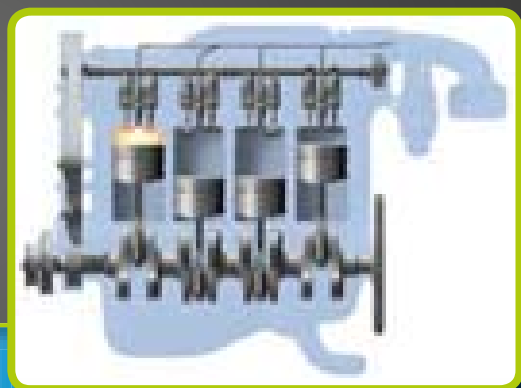

● ● ● DISC HARROW

- 11 2x
- 14 1x
- 18 2x
- 19 1x
- 28 1x
- 33 2x
- 36 5x
- 37 1x
- 42 3x
- 45 3x
- 46 2x
- 47 4x

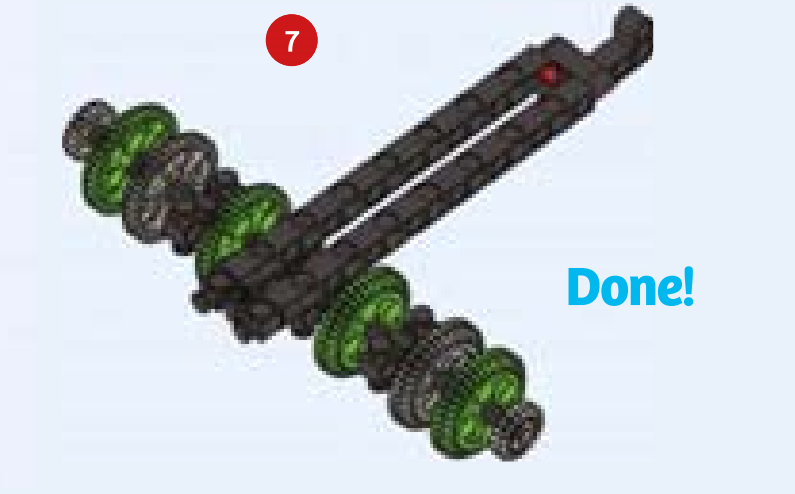
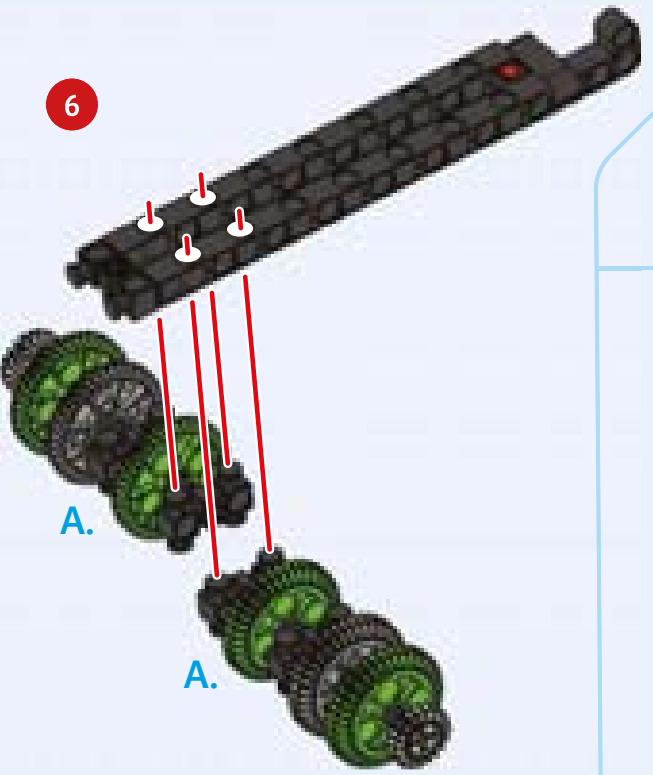
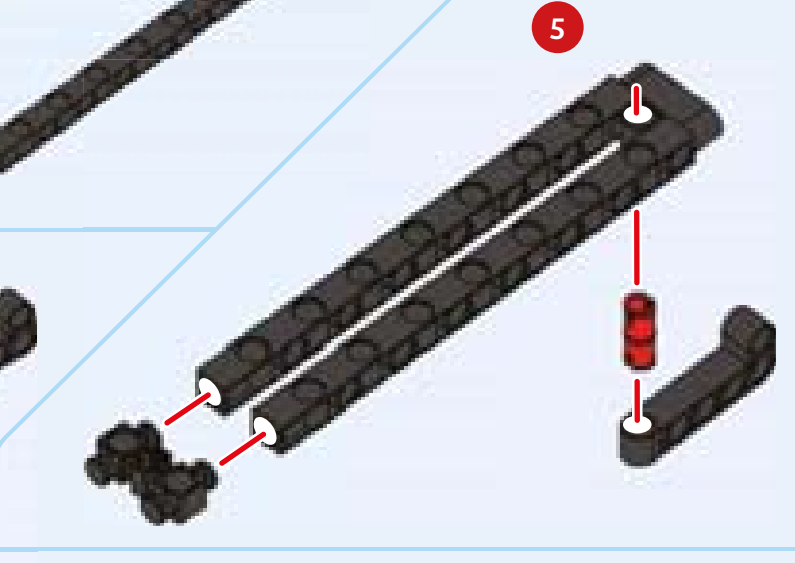
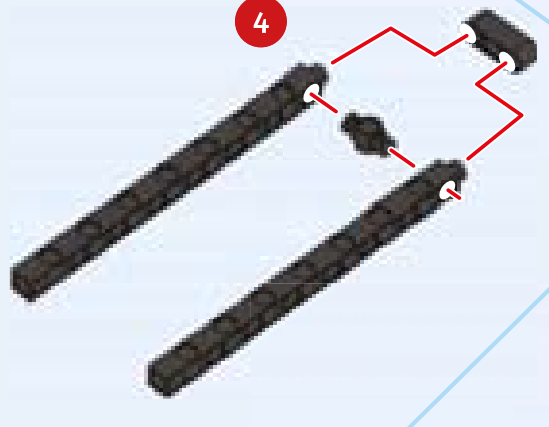
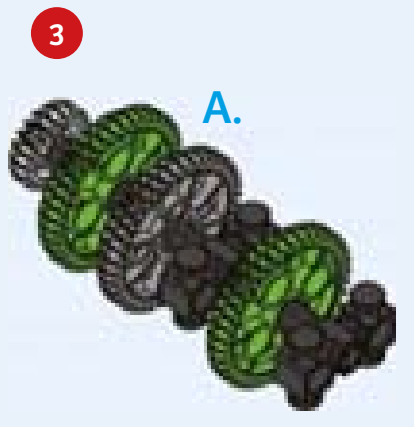
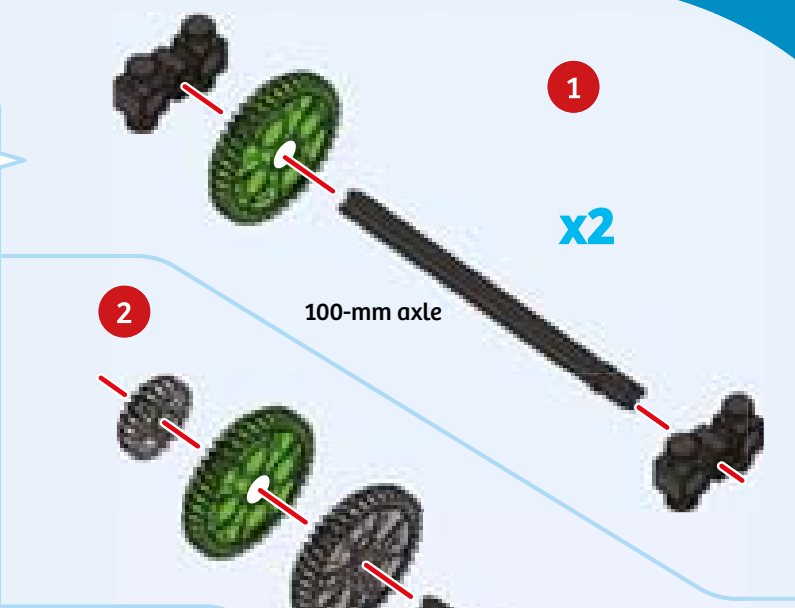



DISC HARROW

1

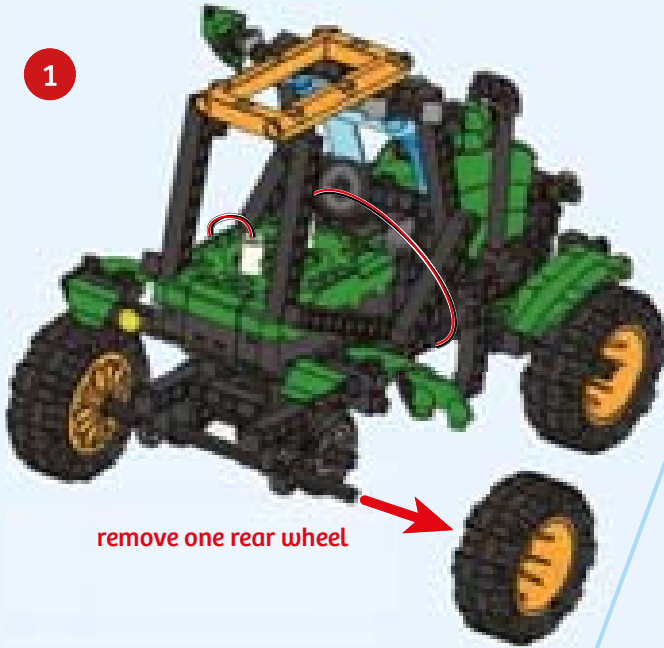

2

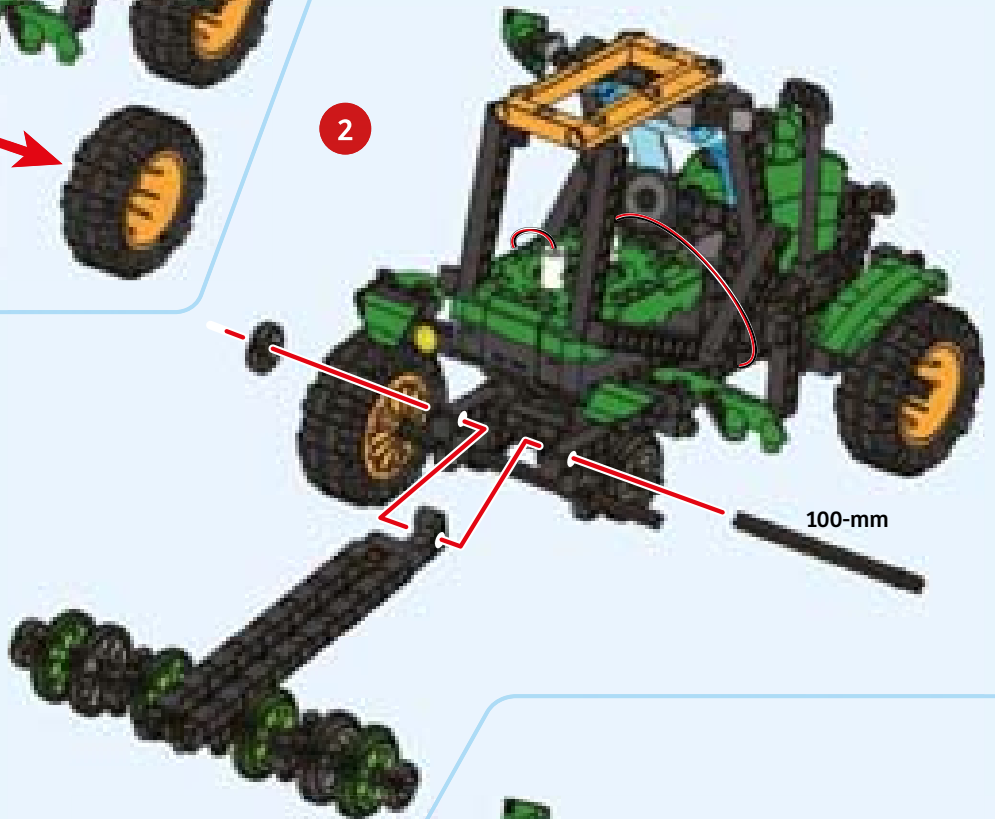

3

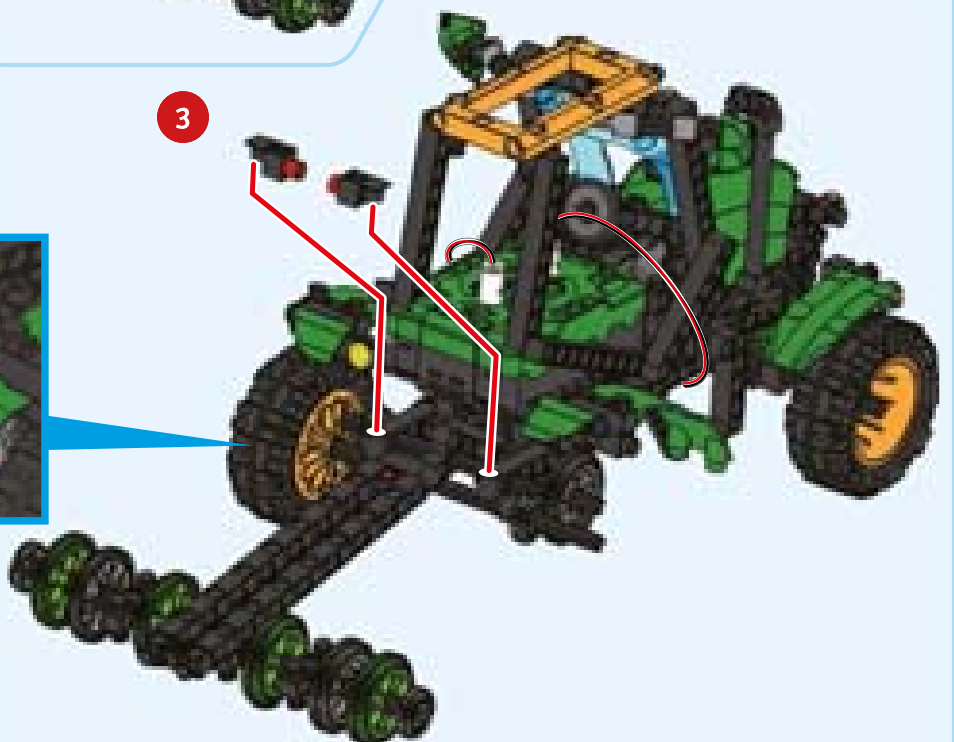

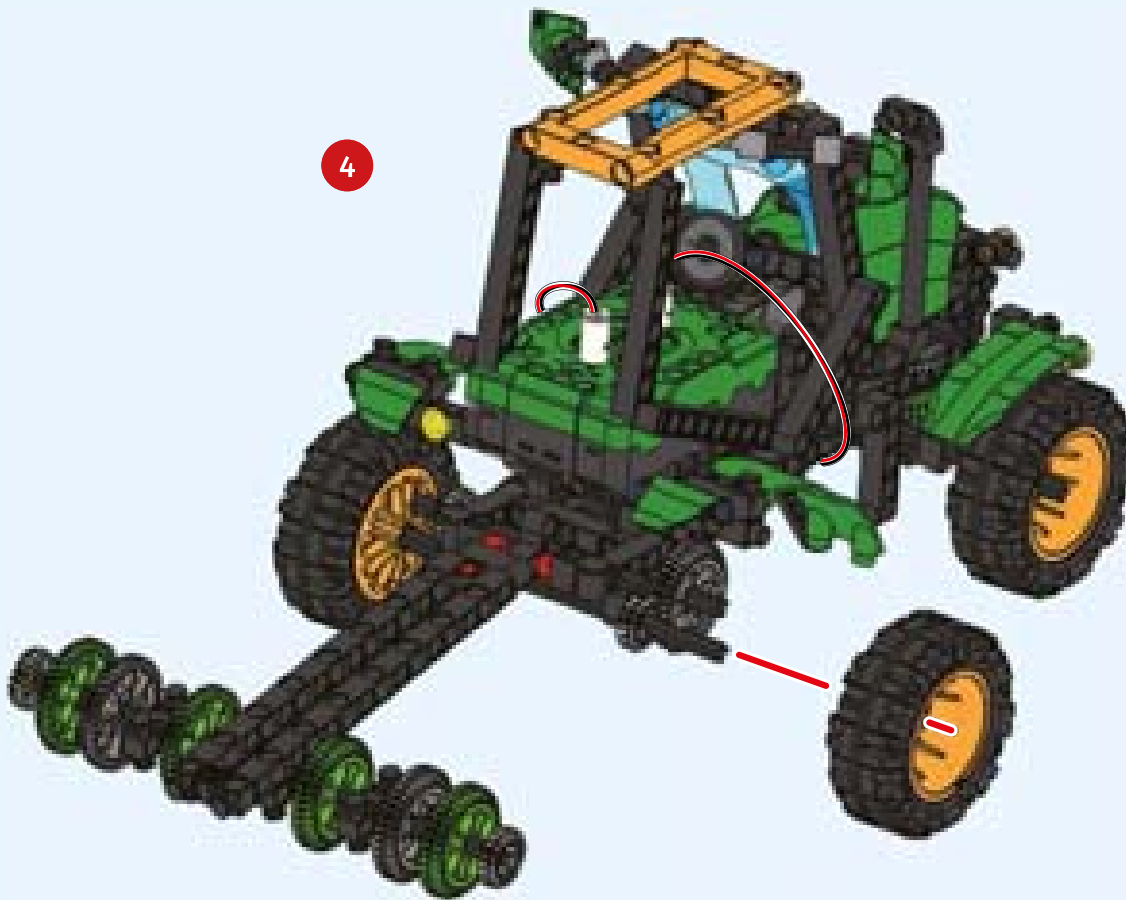

EXPERIMENT 2

Tilling soil

HERE'S HOW

Have the tractor drag the disk harrow attachment through a thin layer of fine sand. Flatten the sand and then run the disk harrow attachment through the sand again but with the disk closer together. What do you observe happens to the pattern formed in the sand?

Done!

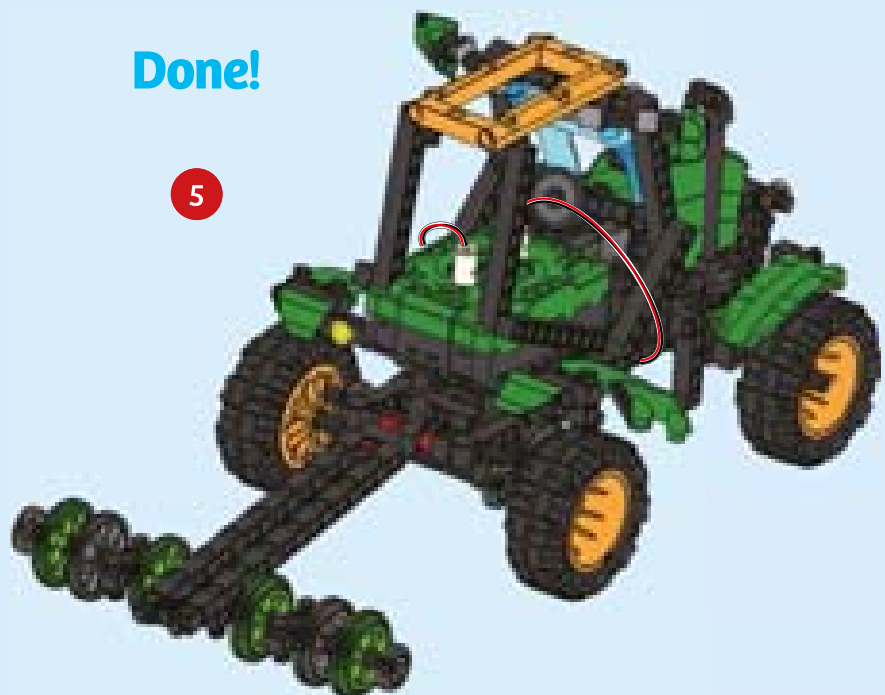

CHECK IT OUT



PREPARING THE SOIL FOR PLANTING

The physical characteristics of soil are very important for the growth of plants. Soil consists of very small particles of organic matter with spaces in-between the particles. The size of these spaces, determine the ability of soil to hold and conduct water, nutrients, and air to the roots of plants. If the soil particles are spaced to close together (called soil compaction) water and air can't pass through the soil easily. Soil compaction also makes it harder for the roots of plants to break through the soil.

Compacted Soil

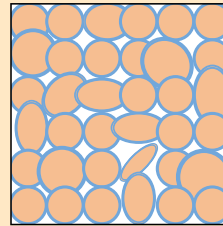

Ideal Soil

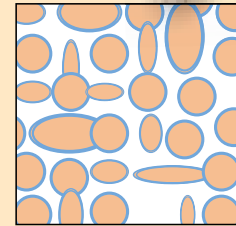

Soil Solid



Water



Air



The process of preparing the soil for planting is called tilling. The best-known tillage device is the plow. In the U.S. plows have been replaced by implements that use offset discs, similar to ones used by the disc harrow, or chisels. Plowing is done first to provide a deeper tillage, while harrowing is often carried out after plowing to provide a finer finish.

SIMPLE MACHINES: THE WEDGE

Farm machines, such as tractors or disc harrows, are very complex machines. To make it easier to understand and analyze them, you can break them down into a combination of many simple machines that work together.

The blade of a plow or the disc of a harrow are a simple machine called a **wedge**. Wedges are used to make splitting, pushing apart, or cutting materials easier. The blade of an axe is another example of a wedge.



WHAT IS A SIMPLE MACHINE?

A simple machine is a mechanical device that changes the direction or magnitude of a force. A **force** is simply a push or a pull. A simple machine takes one input force and produces an output force, which is used to do work. Simple machines are used to make doing work easier.

CULTIVATOR

- 12 18x
- 14 2x
- 15 6x
- 19 1x
- 22 4x
- 23 2x
- 28 2x
- 30 2x
- 32 1x
- 33 2x
- 36 5x
- 37 1x
- 42 1x
- 45 1x
- 53 2x

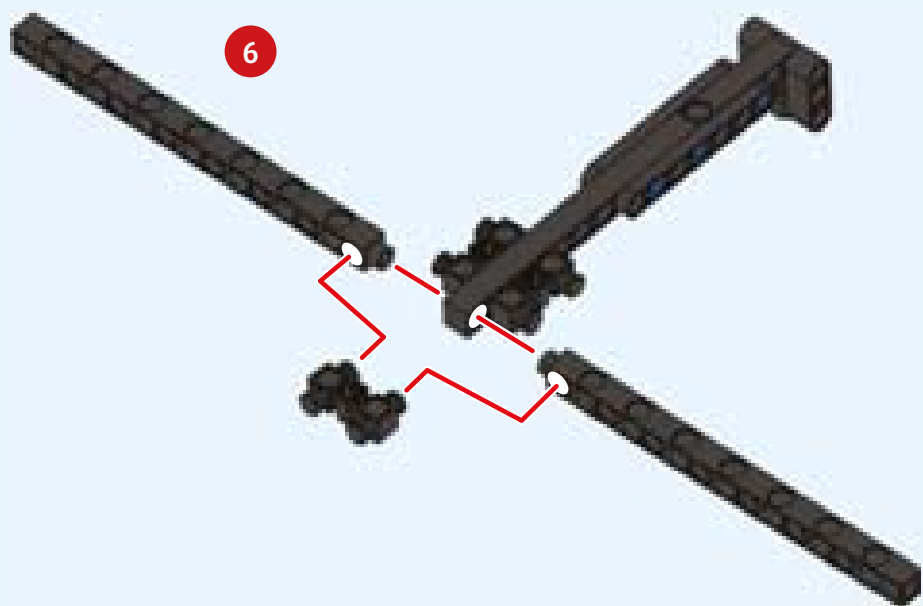
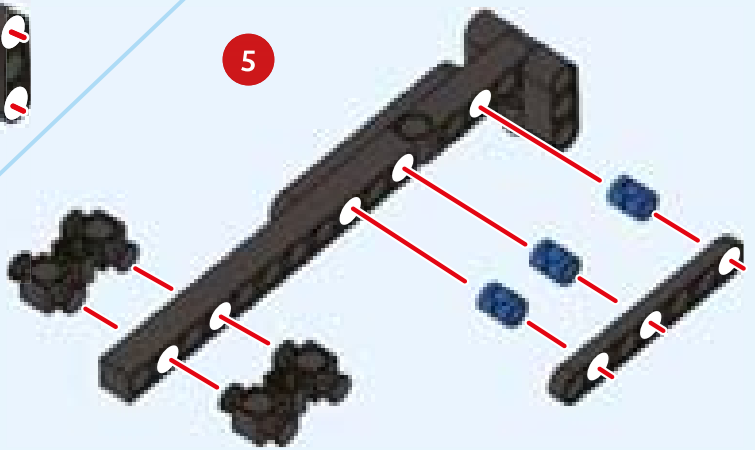
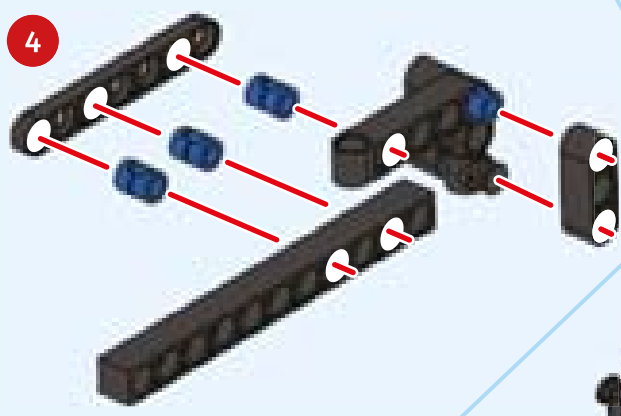
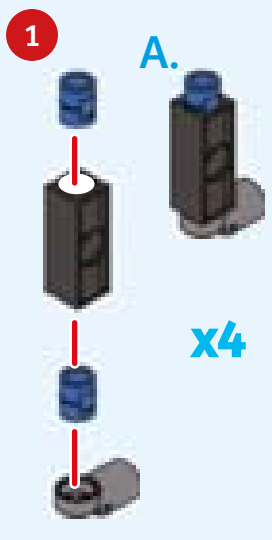



CULTIVATOR

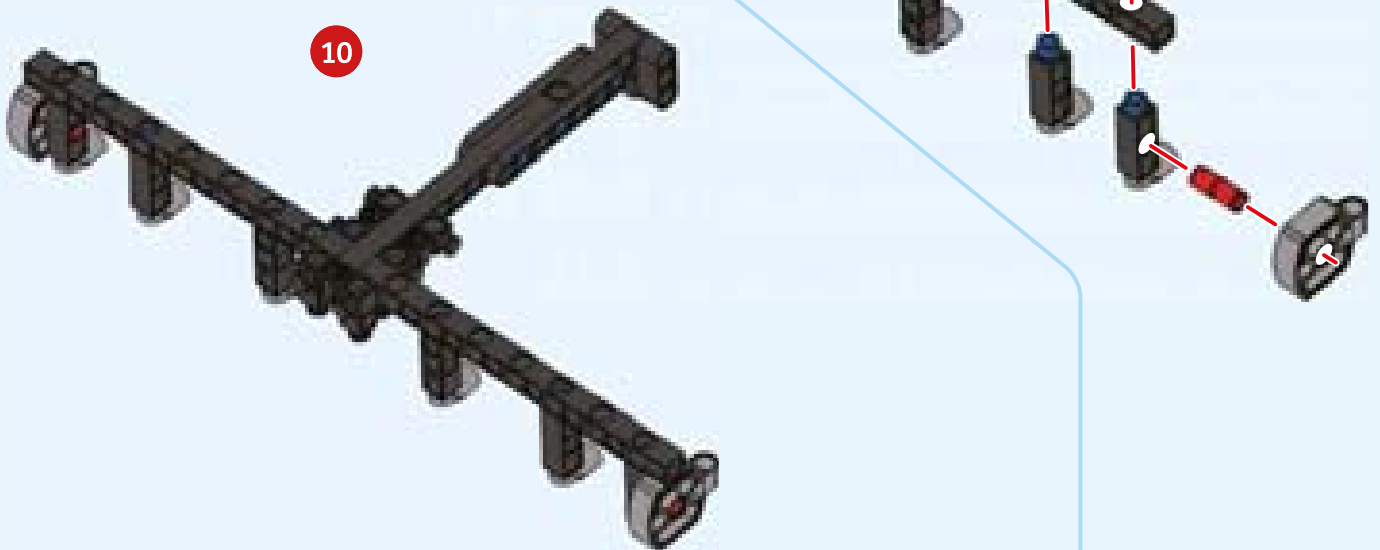
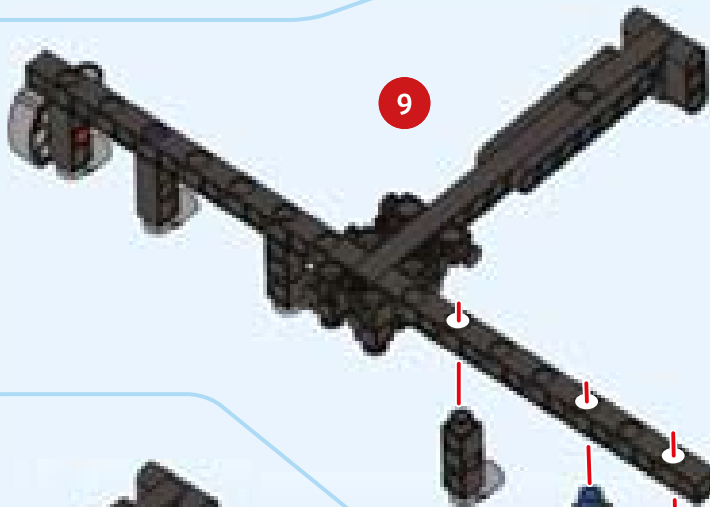
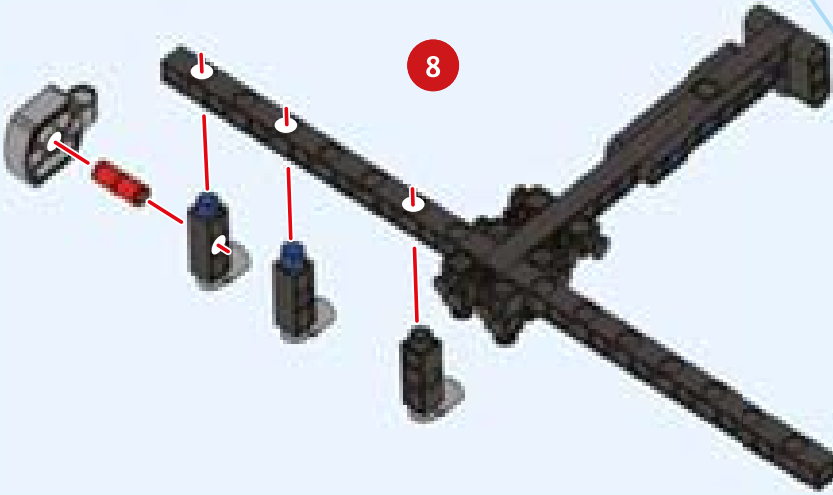
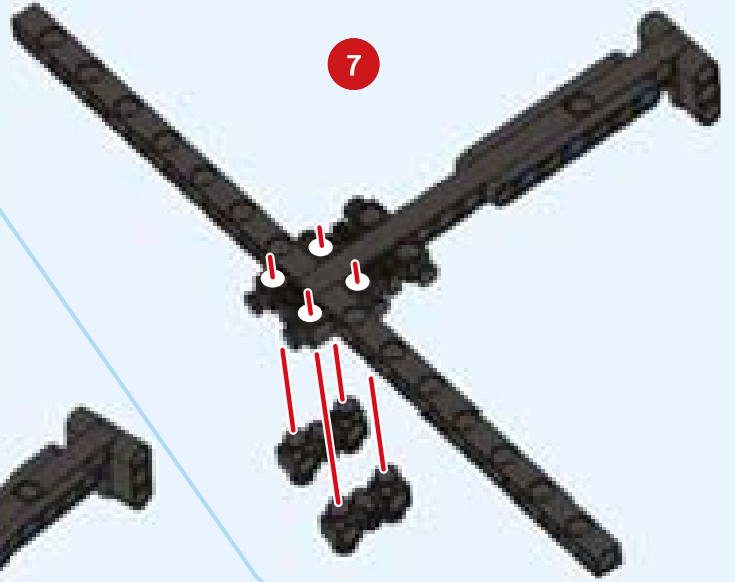

11



12

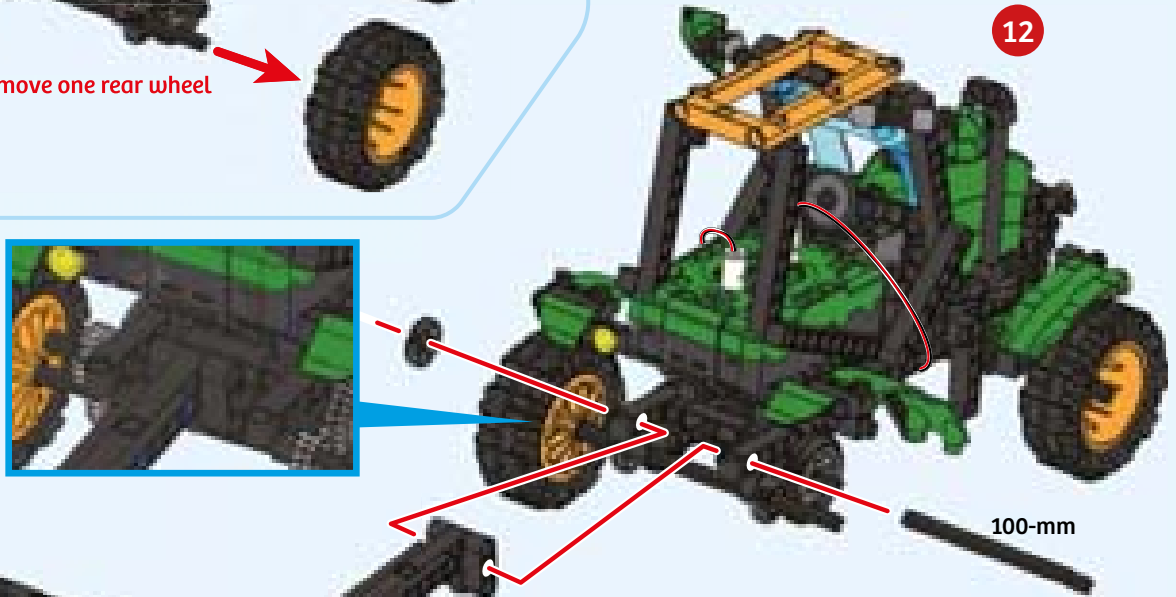

13

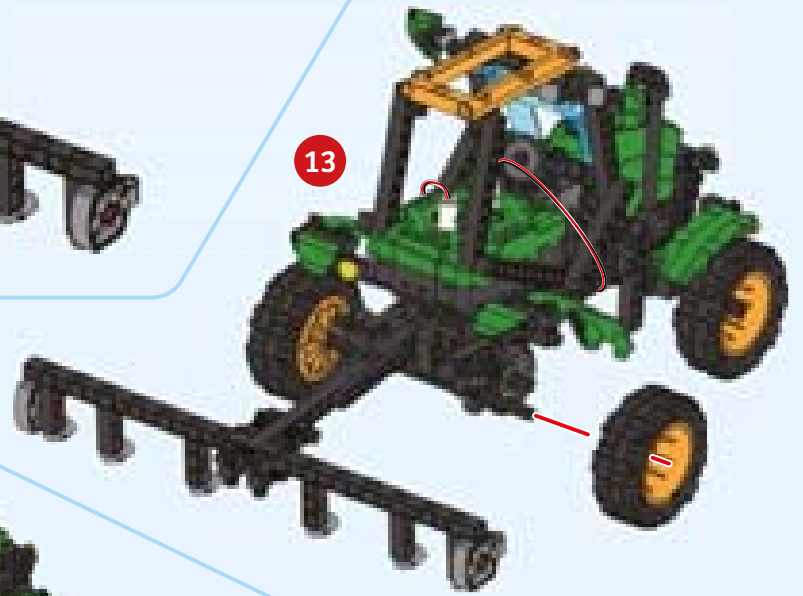

14



Done!

CHECK IT OUT



Just like the disc harrow, cultivators are also used for secondary tillage after a field has been ploughed. However, cultivators are designed to disturb the soil surface in specific patterns so that crop plants are spared and weeds are killed.

Cultivators that are attached to tractors using what is called a three-point hitch. If the cultivator needs mechanical power from the tractor it can also be attached to a power takeoff (PTO) shaft on the tractor.

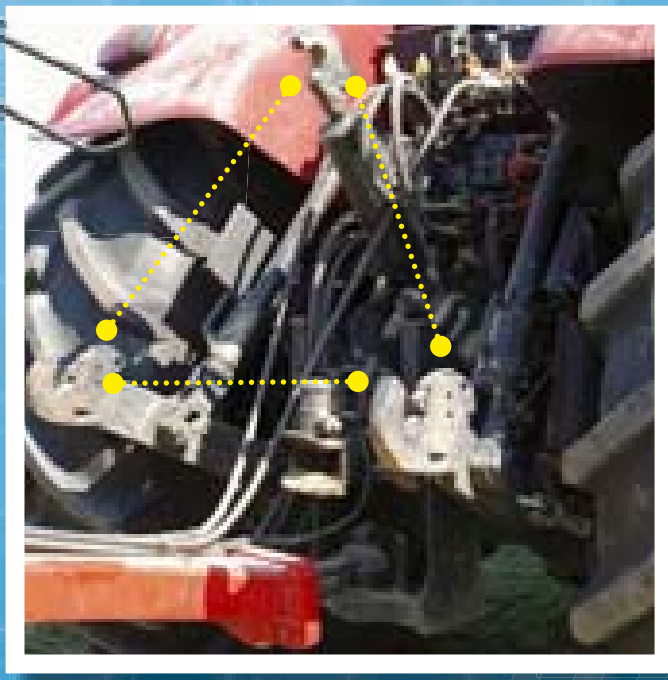

Three-point Hitch

The three-point hitch is used to attach implements to tractors. The three attachment points of the three-point hitch are positioned like the points of a triangle. The lower two attachment points are often connected to the hydraulic system of the tractor allowing the attachment to be lifted up and down.

The three-point hitch is used because it is the simplest way to attach an implement to a tractor, in which the implement is held in a fixed position with respect to the tractor. An advantage of using a three-point hitch is that it transfer some or all of the weight of the attachment to the tractor.



Power takeoff (PTO)

A power takeoff is a drive shaft which is connected to the engine of the tractor. It can be used to transfer mechanical power to farm implements that are attached to the tractor.

● ● ● SEEDER

- 11 1x
- 12 19x
- 14 5x
- 18 2x
- 19 3x
- 22 4x
- 23 2x
- 23 2x
- 28 2x
- 29 1x
- 30 3x
- 32 1x
- 33 2x
- 36 5x
- 37 1x
- 47 4x
- 50 1x

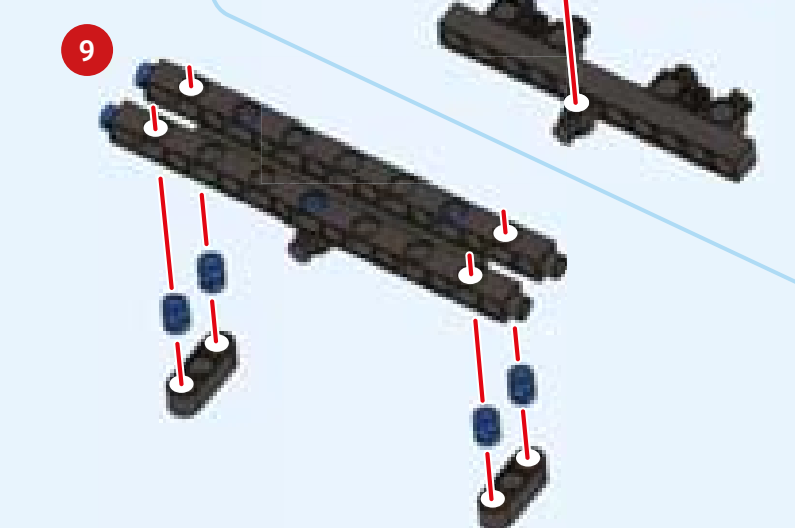
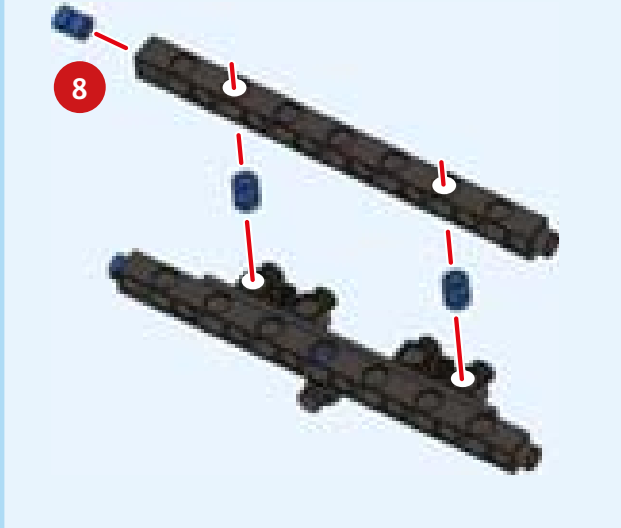
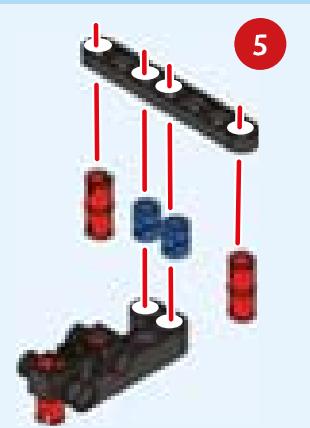
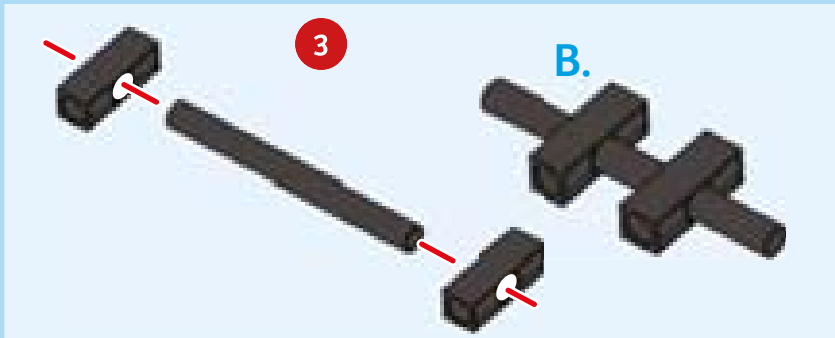
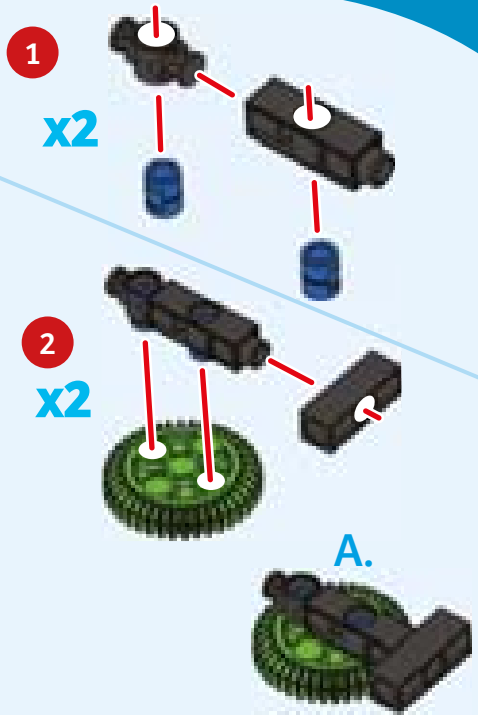



SEEDER

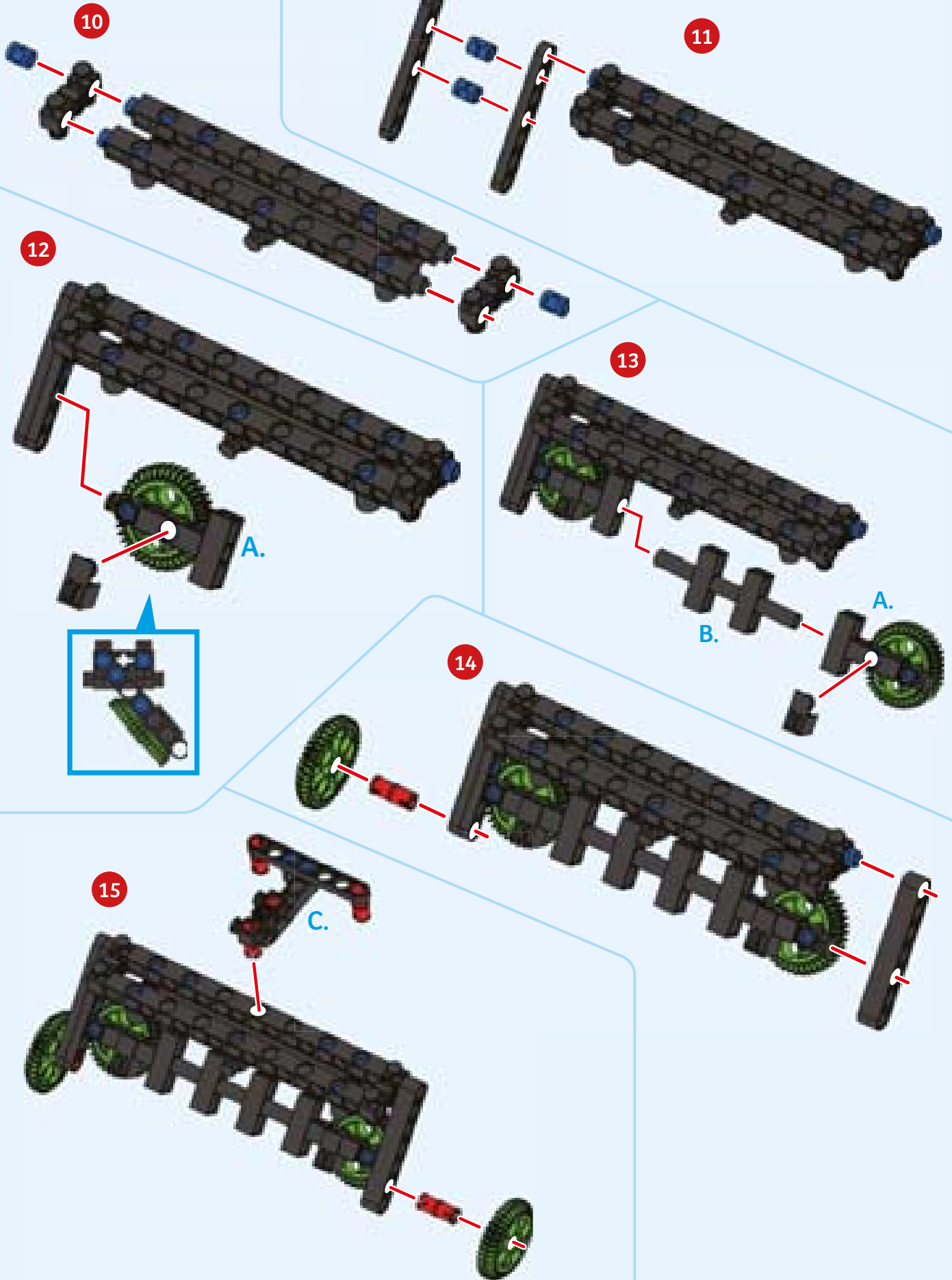

16



17

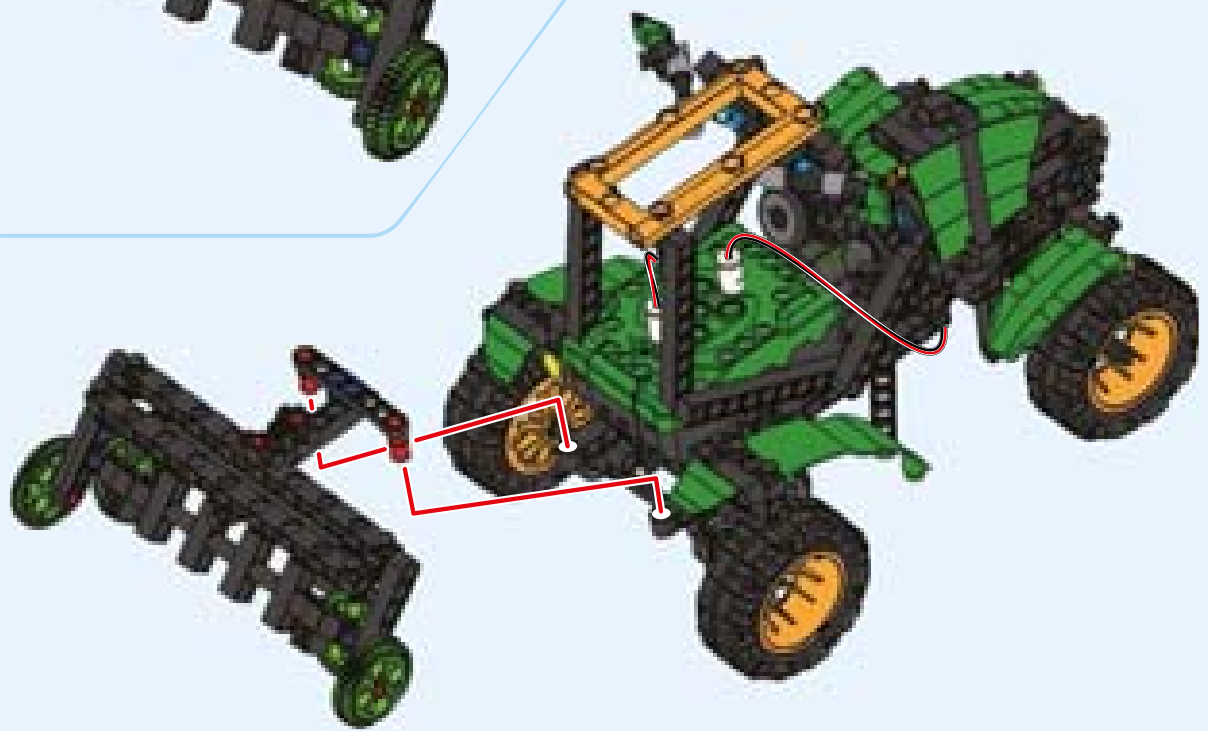

18

Done!

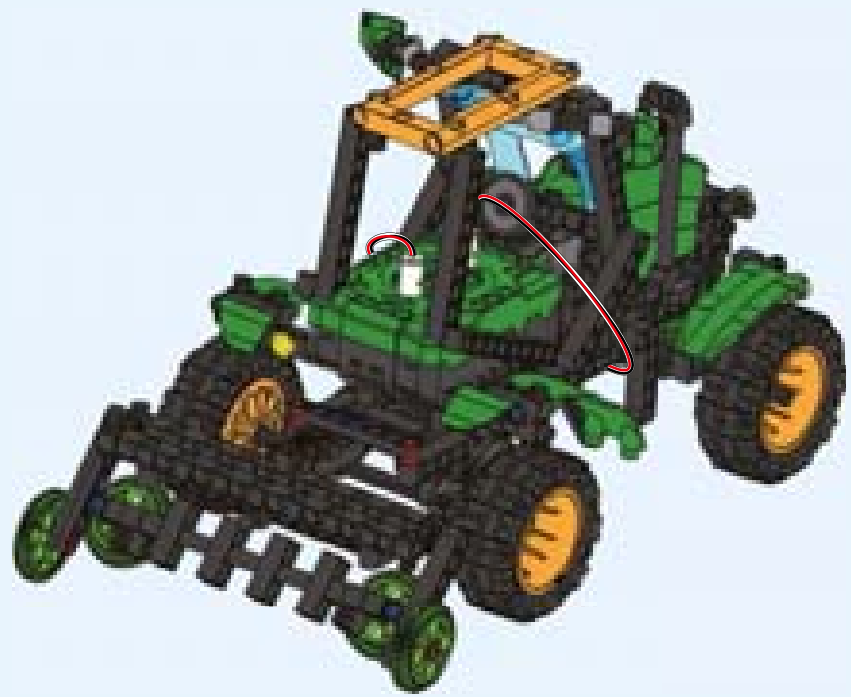

CHECK IT OUT



A seeder sows seeds by metering out individual seeds, placing them in the soil, and then covering them up. A seeder ensures that the seeds are planted at the correct depth and space from each other and ensures that they are not eaten by birds. The use of seeders makes sure that more of the seeds grow into plants, increasing crop yield.

SOIL CHEMISTRY

To ensure proper plant growth soil must also have the correct **soil chemistry**. The two fundamental factors in soil chemistry are **fertility** and **pH**.

pH

pH is a measure how acidic or basic a solution is. An **acid** is a substance that gives off hydrogen ions (H^+) when dissolved in water. While **bases** are substances that give off hydroxide ions (OH^-) when dissolved in water. You encounter many acids and bases every day. Vinegar and lemon are examples of acids, while baking soda and ammonia are bases.

The pH scale goes from 0 to 14. Values below 7 are acidic and values above 7 are basic. Pure water has a pH of 7, which is considered neutral — neither acidic or basic.

The pH of soil is measured by mixing the soil in water and using an **indicator**. The indicator changes color if it is placed in an acid or base. pH is important for plant growth and health because it influences many different chemical process. For example, pH affects the availability of different nutrients. The proper pH range for most plants is between 5.5 and 7.5.

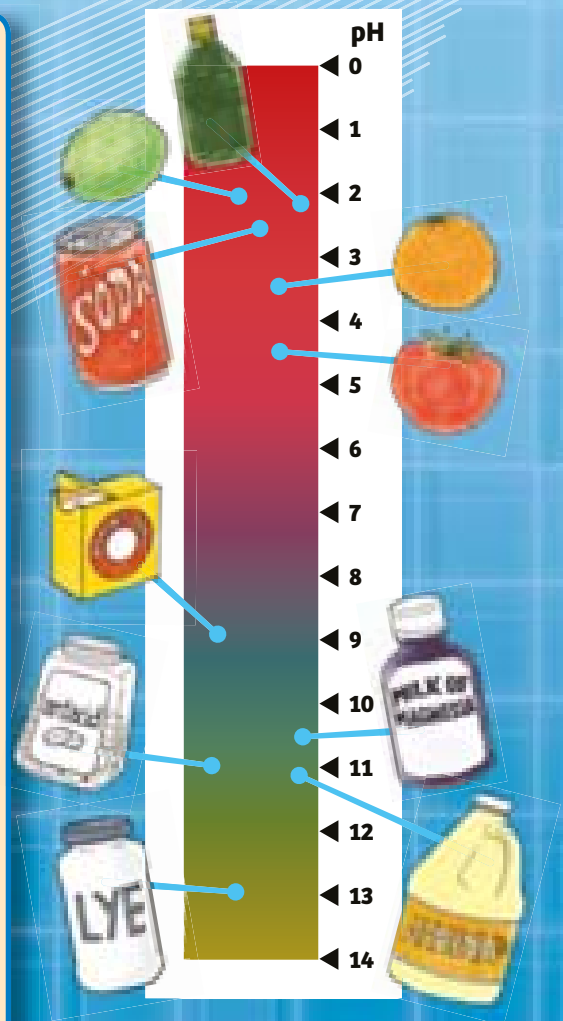

pH scale with the pH of some common items.

Fertility

The fertility is a measure of the nutrients available in soil, primarily the amount of nitrogen, phosphorus, and potassium or **NPK**. These three elements are vital to the growth of plants. You can often see the amount of NPK in fertilizers on their label.



HAY RAKE

- 11 2x
- 12 21x
- 14 4x
- 15 10x
- 18 2x
- 19 2x
- 22 2x
- 23 2x
- 28 2x
- 30 2x
- 32 2x
- 33 1x
- 36 2x
- 39 1x
- 41 3x
- 42 1x
- 45 4x
- 46 3x
- 47 4x
- 54 1x

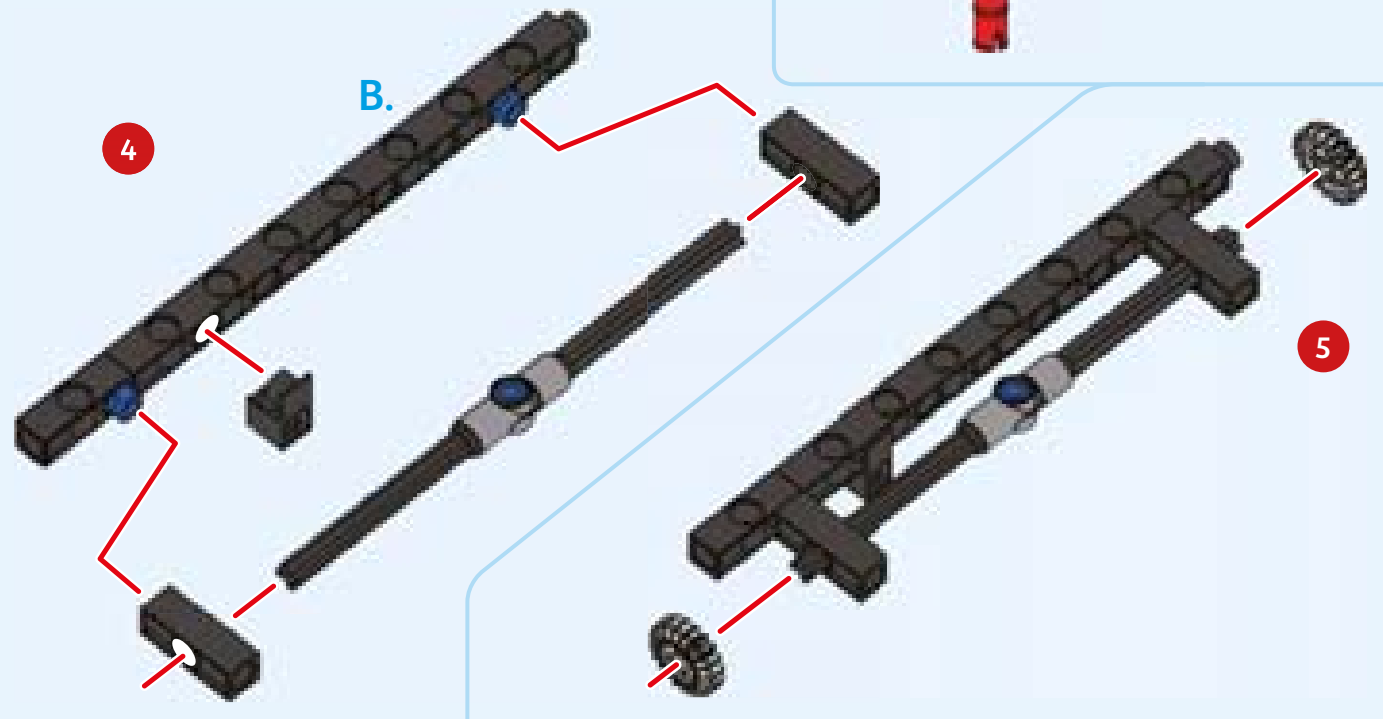
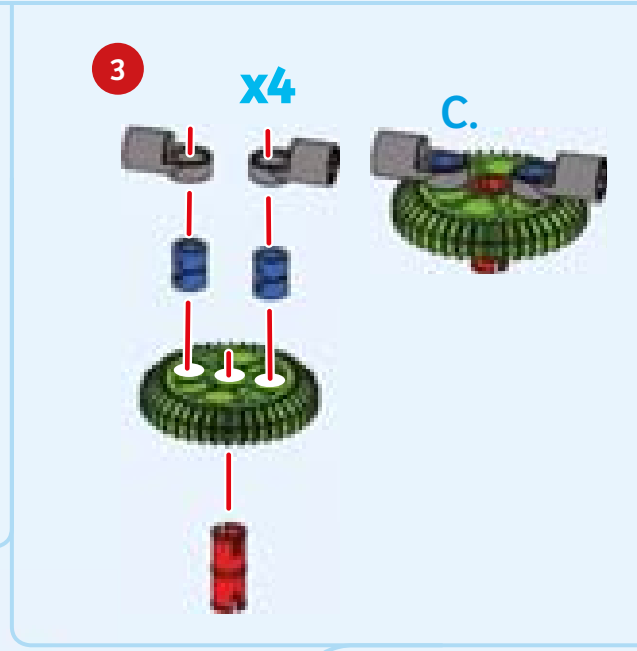
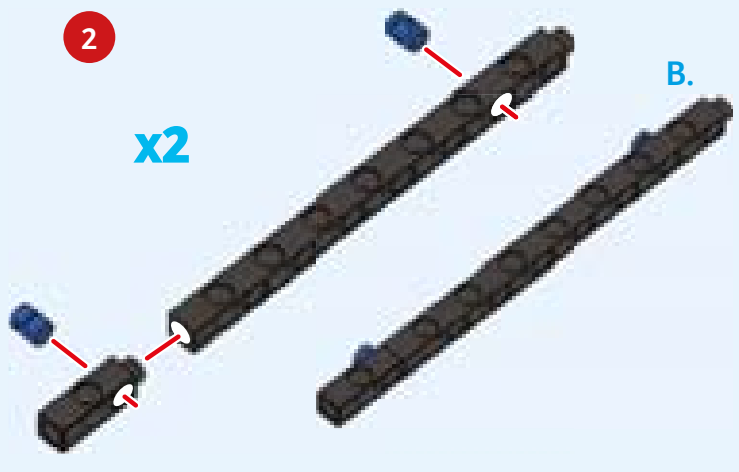
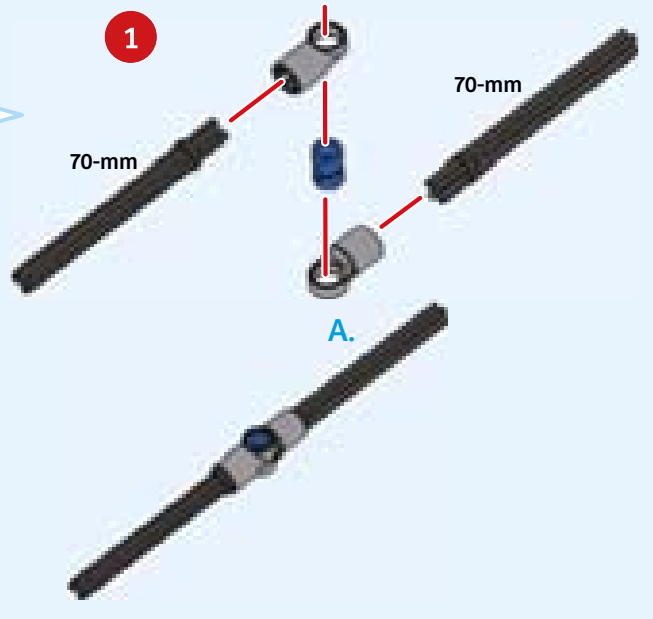



HAY RAKE

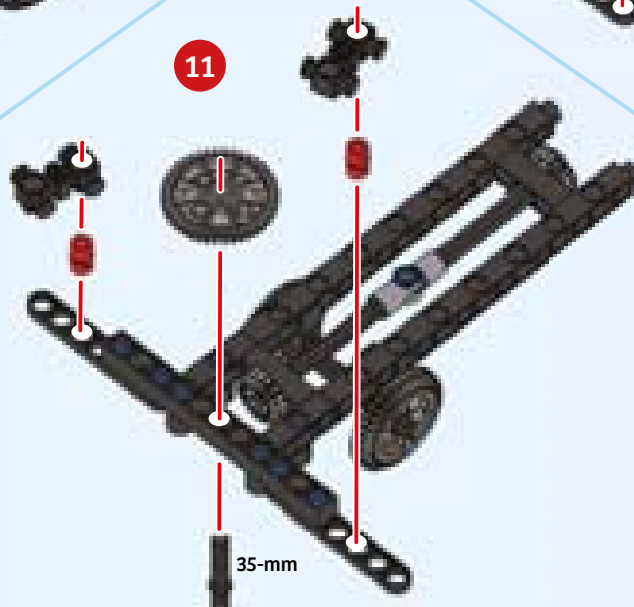
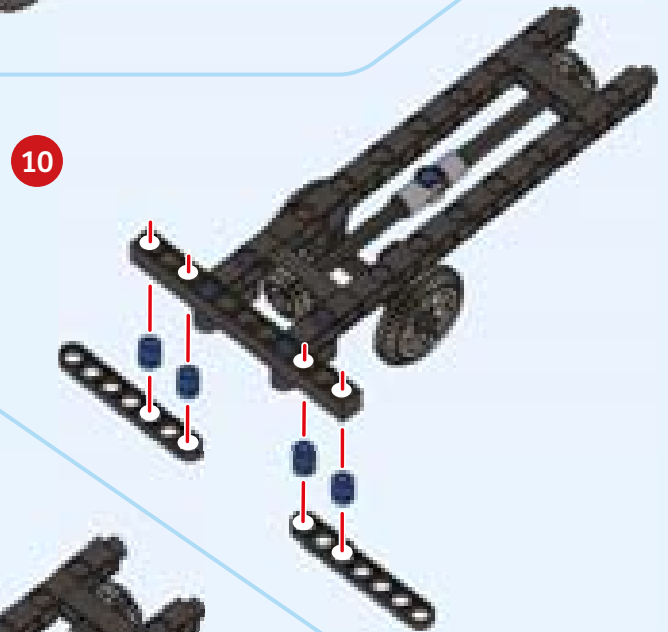
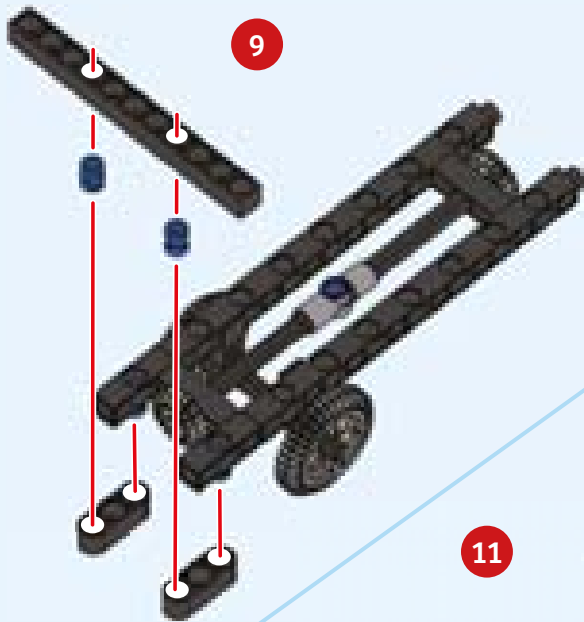
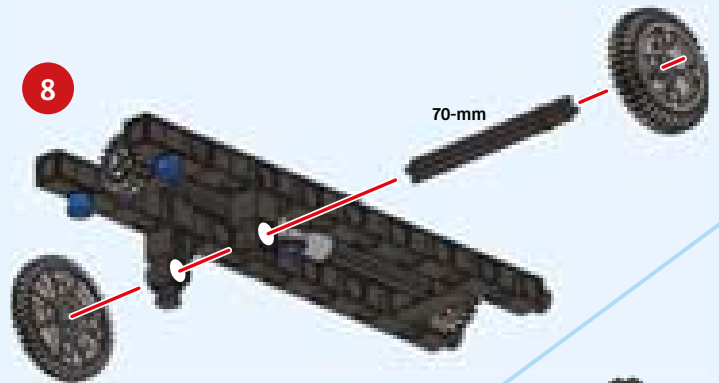
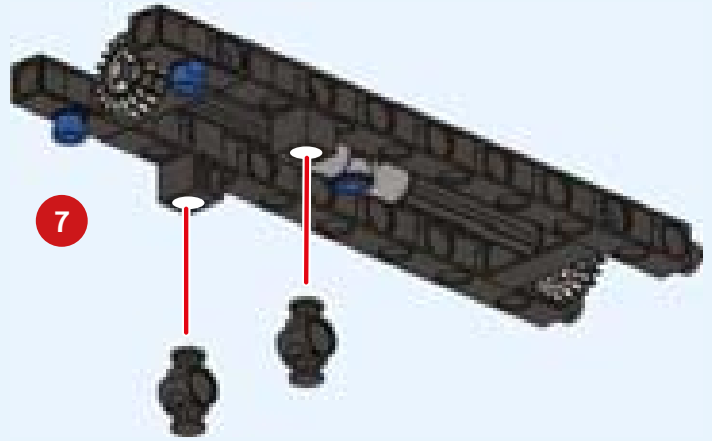
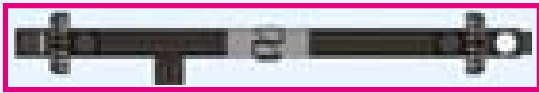
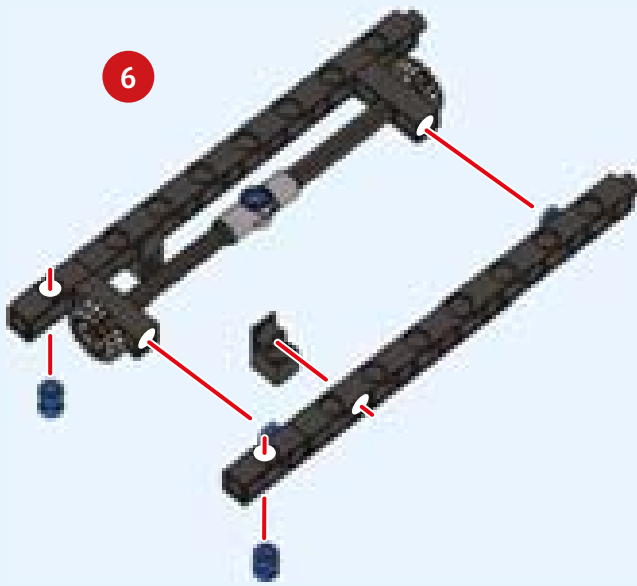

12

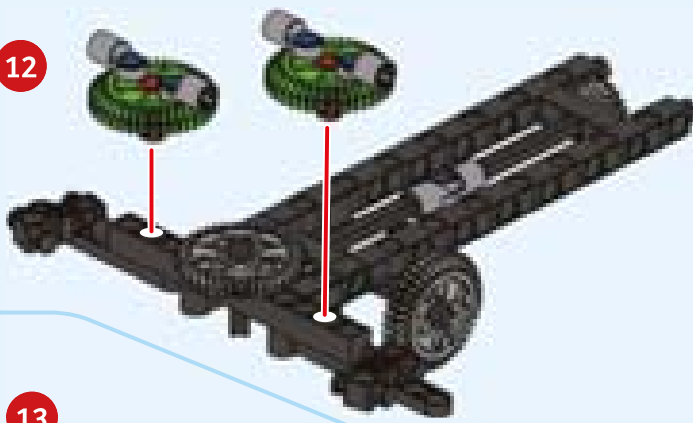

13

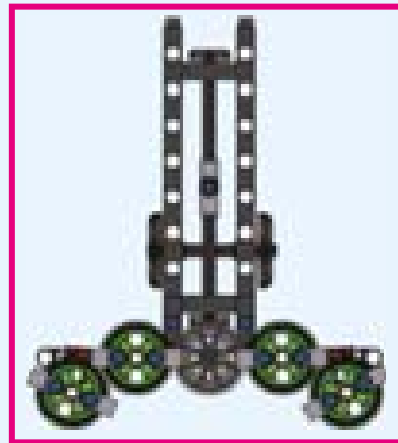
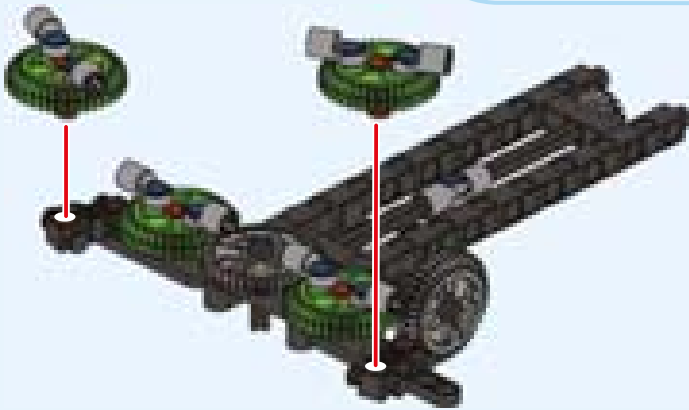

14

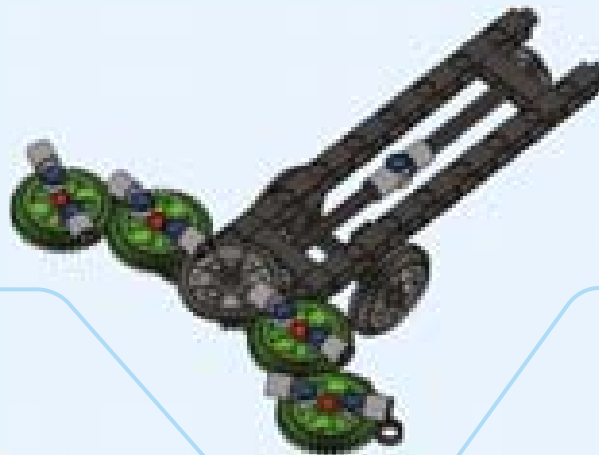

1

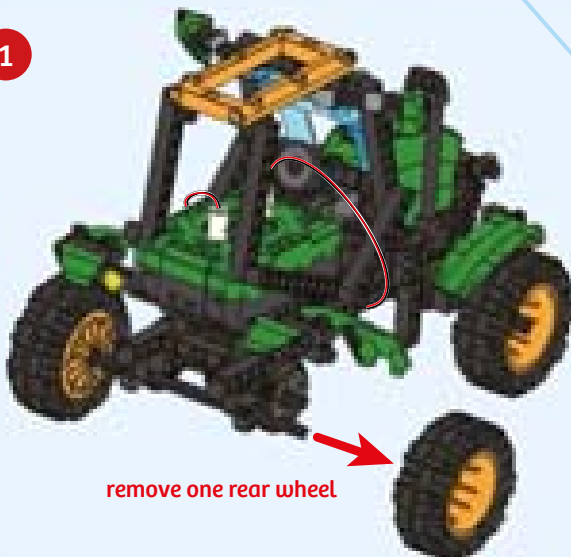

remove one rear wheel

2

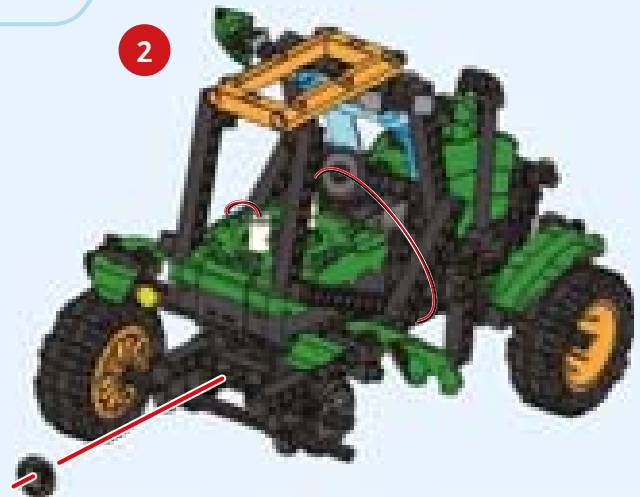

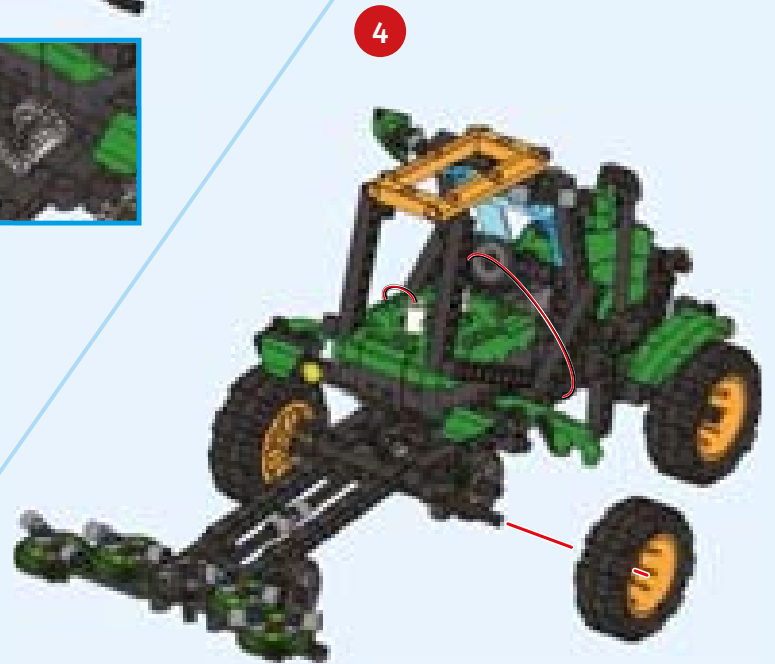
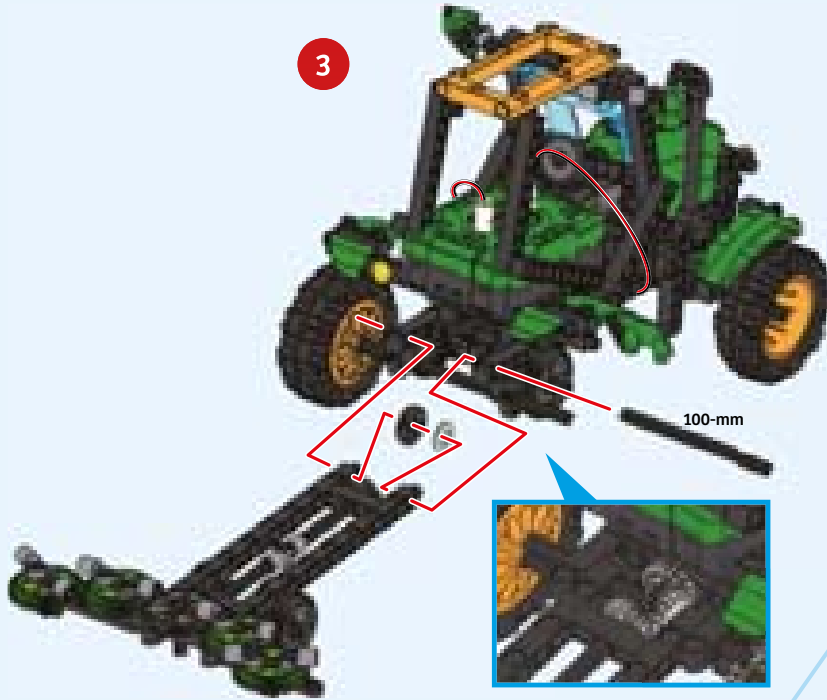

EXPERIMENT 3

Spinning gears

HERE'S HOW

As the gears on the hay rake turn look at the speed of the different gears. What do you observe about the speed of the small gray gears and large green gears?



CHECK IT OUT



MAKING HAY

Hay is made from herbaceous plants, such as grass, and is used to feed animals. Making hay is a multi-step process. First the hay is cut and allowed to dry in the sun. Then it is collected into long, narrow rows known as **windrows** by a hay rake. A hay rake works just like a garden rake that is used to collect leaves. However, the forks of the rake are driven by gears. Finally, the hay is turned into hay bales and stored until it is used.



Image: Windrows

SIMPLE MACHINES: GEARS

Gears are used in many different devices to transfer power. A gear is a rotating wheel that is connected to an axle and has teeth or cogs that are intermeshed with another set of teeth. Gears transfer power by changing the direction, speed, or torque of another gear.

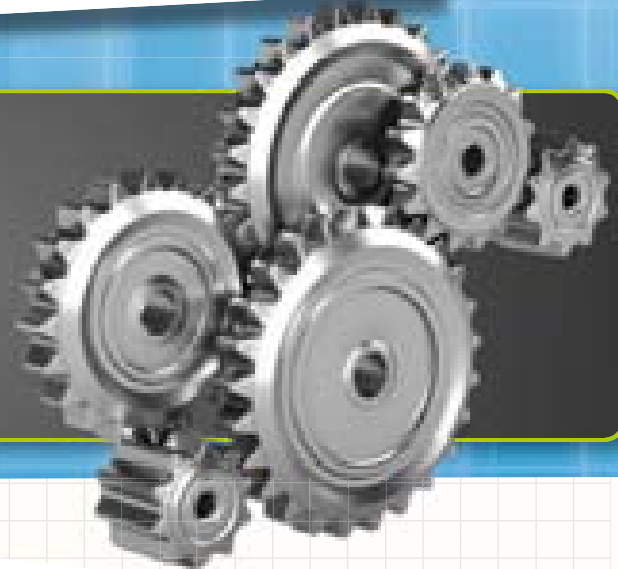

Did you know...

...that gears have been found in insects? In 2013, scientists from the University of Cambridge found gears (right) in the rear legs of the juvenile form of *Issus celoptratus*. The gears make it so that the insect's legs are synchronized when it jumps. The gear mechanism also gives the insect more power when it jumps.





COMBINE HARVESTER

1	2	3	4	6	7	8	10	11	12	13		
1x	1x	2x	3x	1x	1x	1x	2x	8x	93x	1x		
14	15	16	17	18	19	20	21	22	23	24	26	27
8x	21x	2x	4x	4x	27x	1x	1x	6x	2x	2x	2x	3x
28	29	30	31	32	33	34	35	36				
4x	5x	3x	5x	8x	2x	2x	1x	8x				
37	38	39	40	41	42	43	44	45	46	47	48	
9x	2x	3x	4x	5x	9x	1x	2x	12x	6x	5x	1x	1x
50	53	54	55	56	57	58	59	60				
2x	2x	3x	1x	4x	4x	1x	1x	2x				

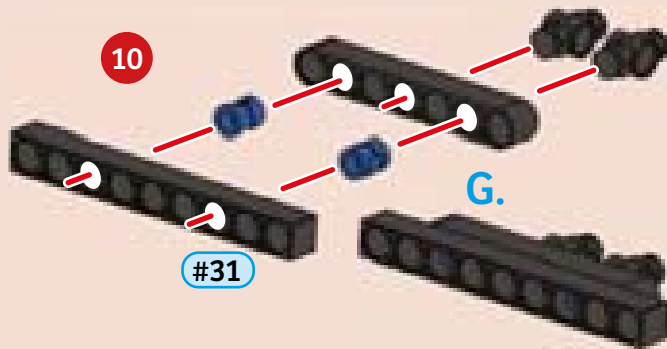
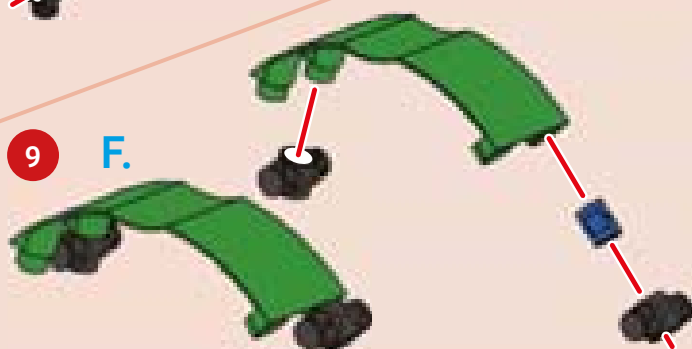
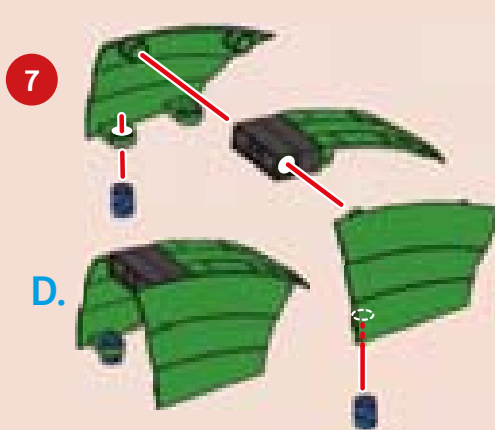
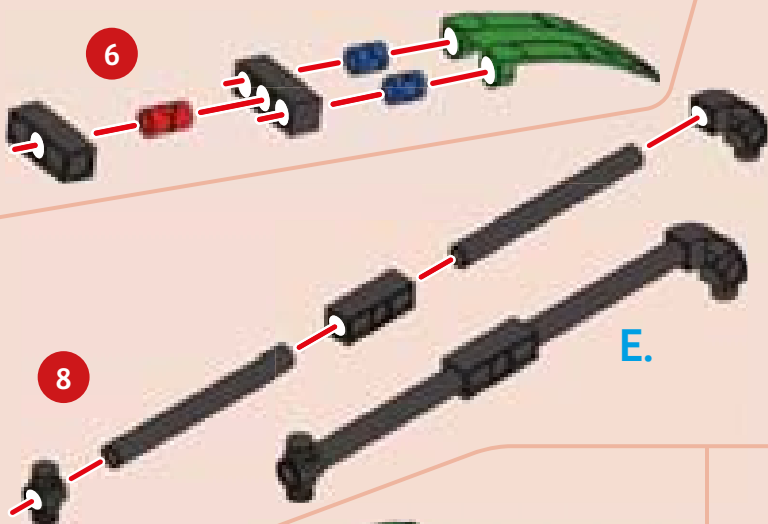
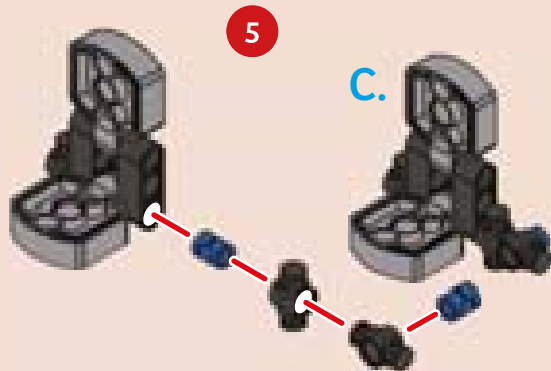
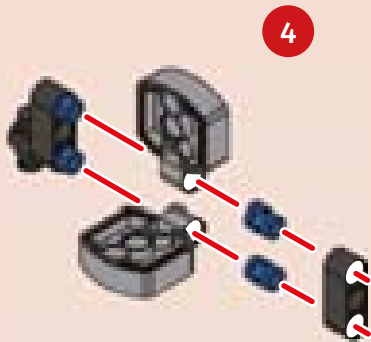
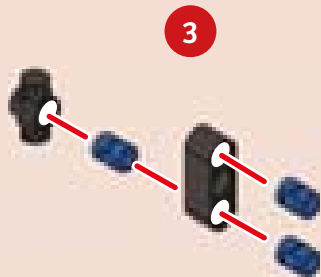
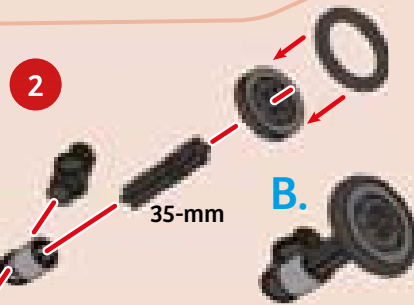
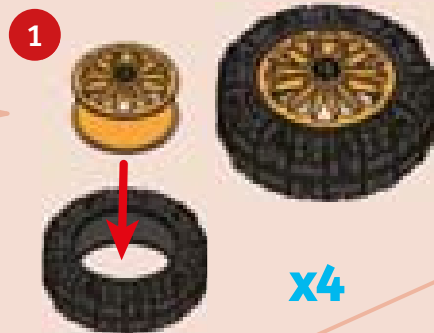

11

G.

F.

H.

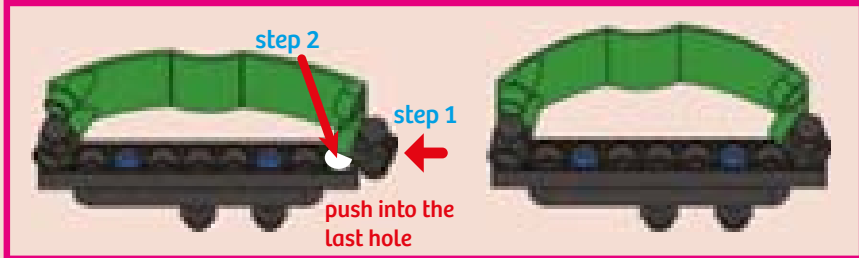

12

#31

I.

13

J.

14

J.

I.

K.

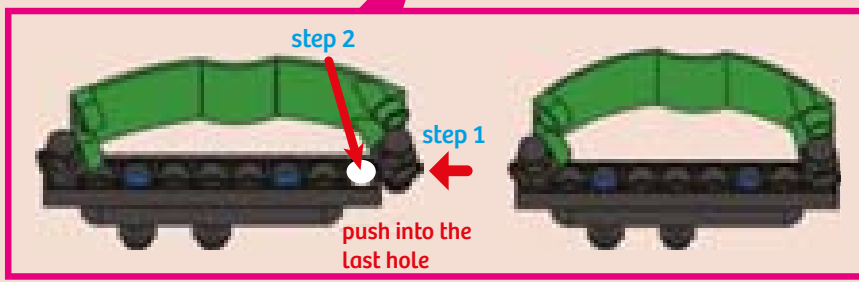

15

#32

16

17

70 mm

70-mm

60-mm



COMBINE HARVESTER

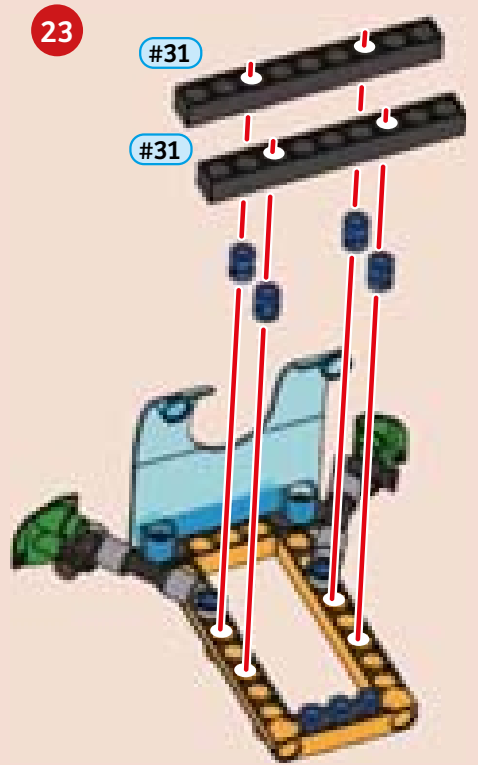
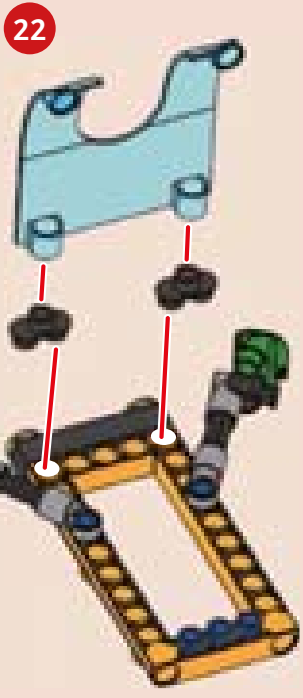
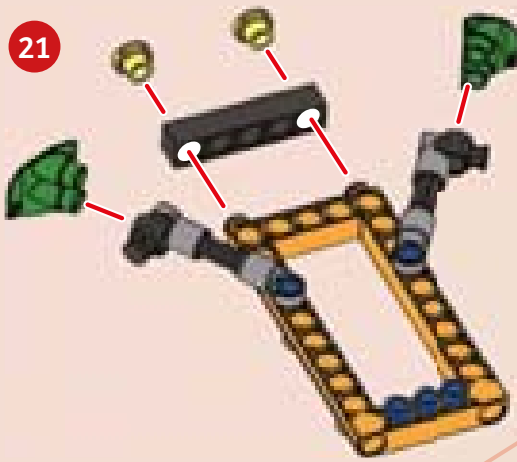
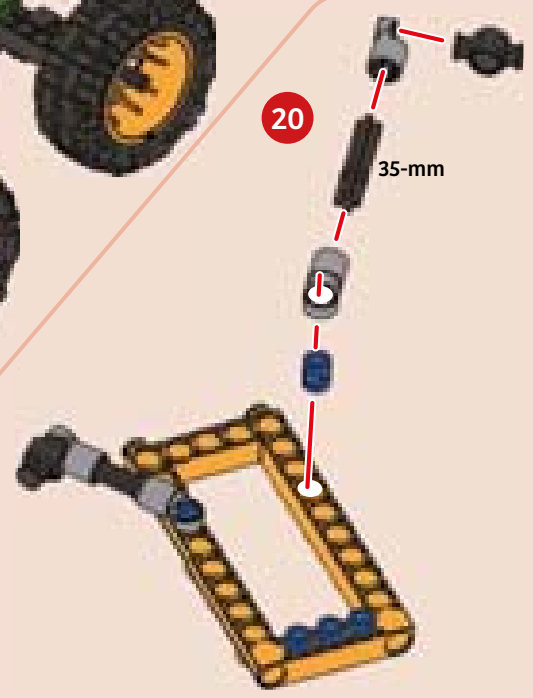
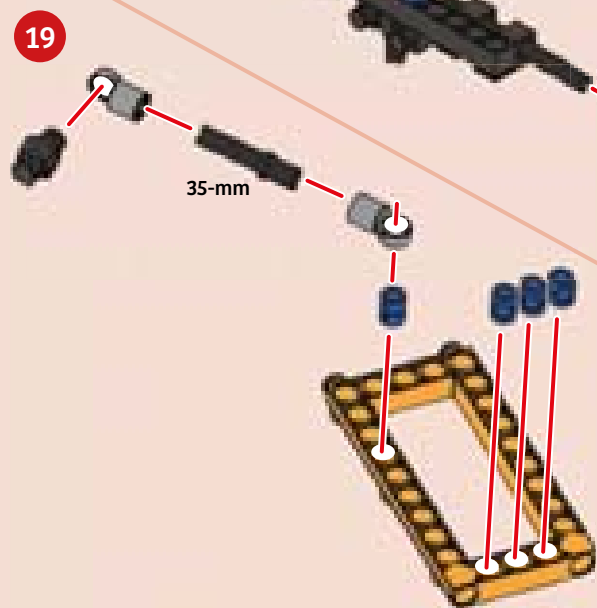
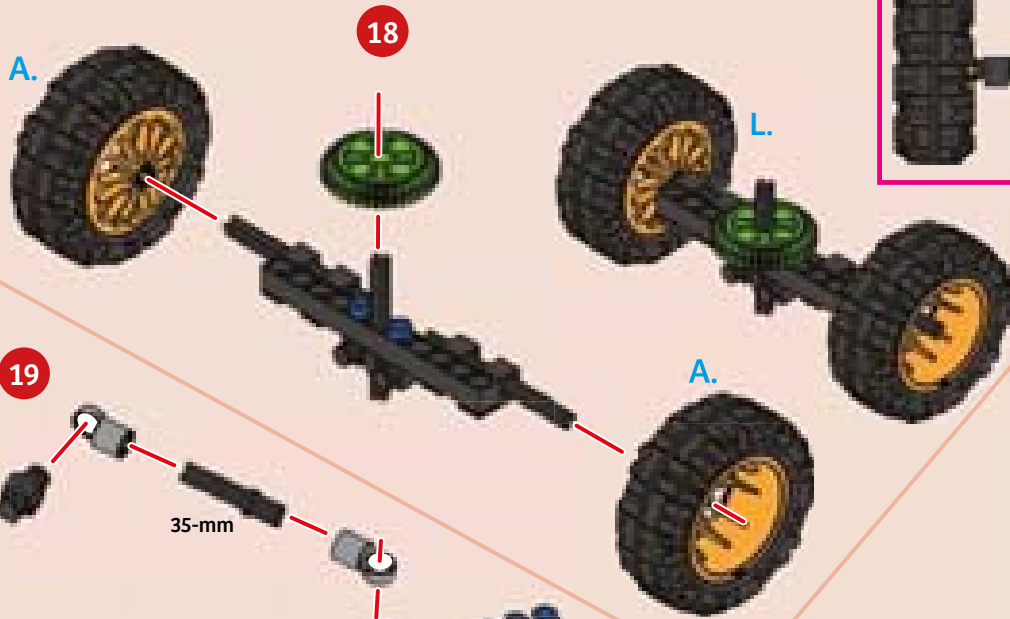
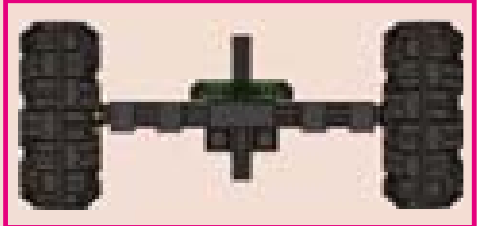

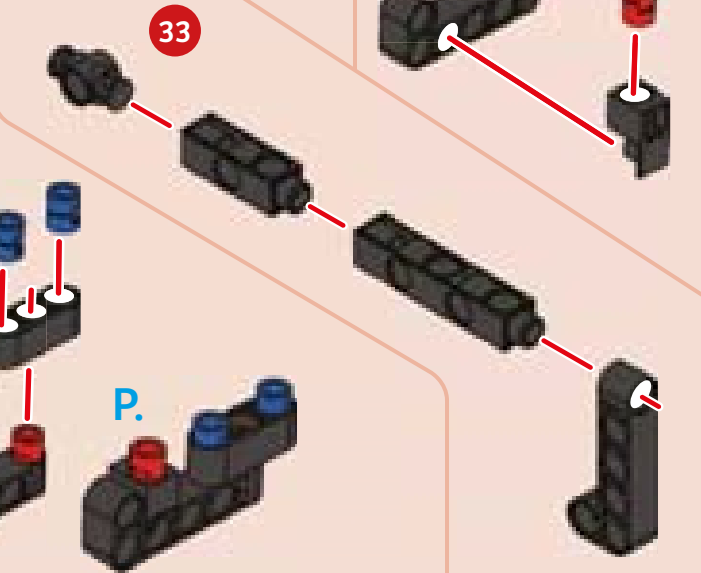
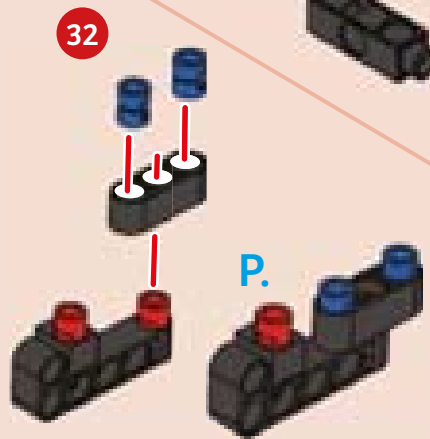
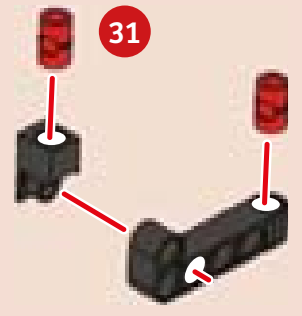
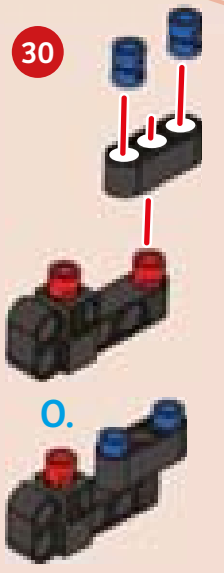
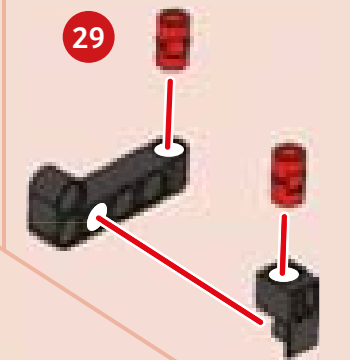
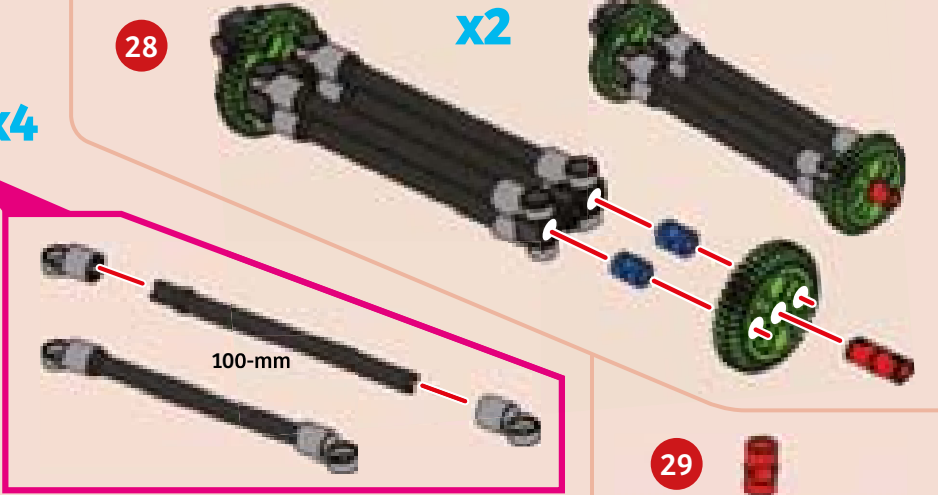
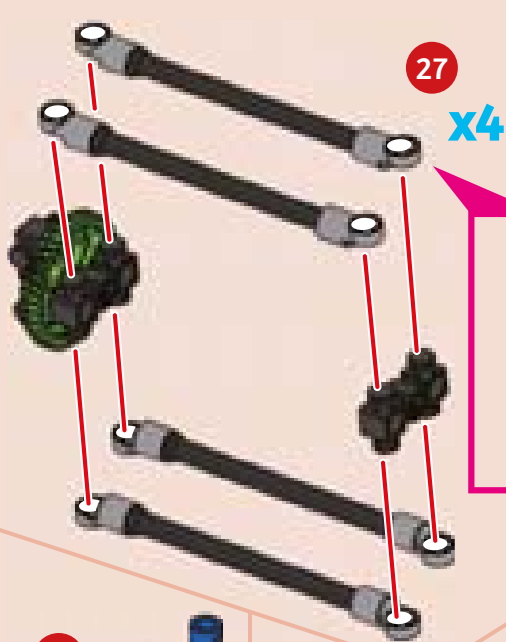
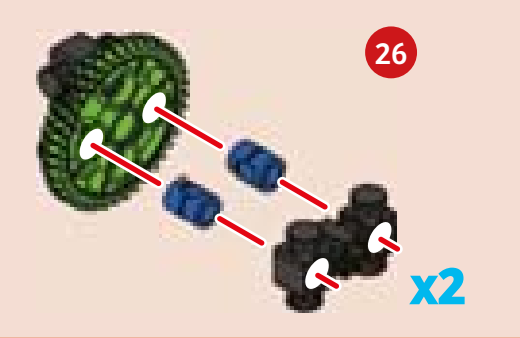
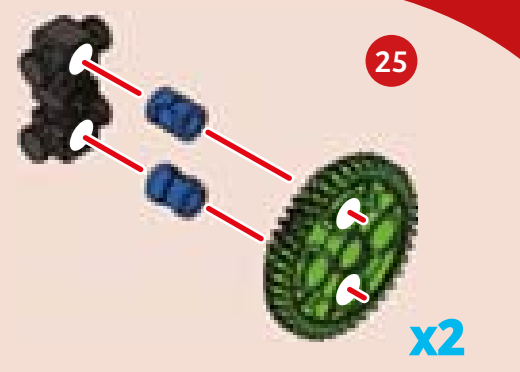
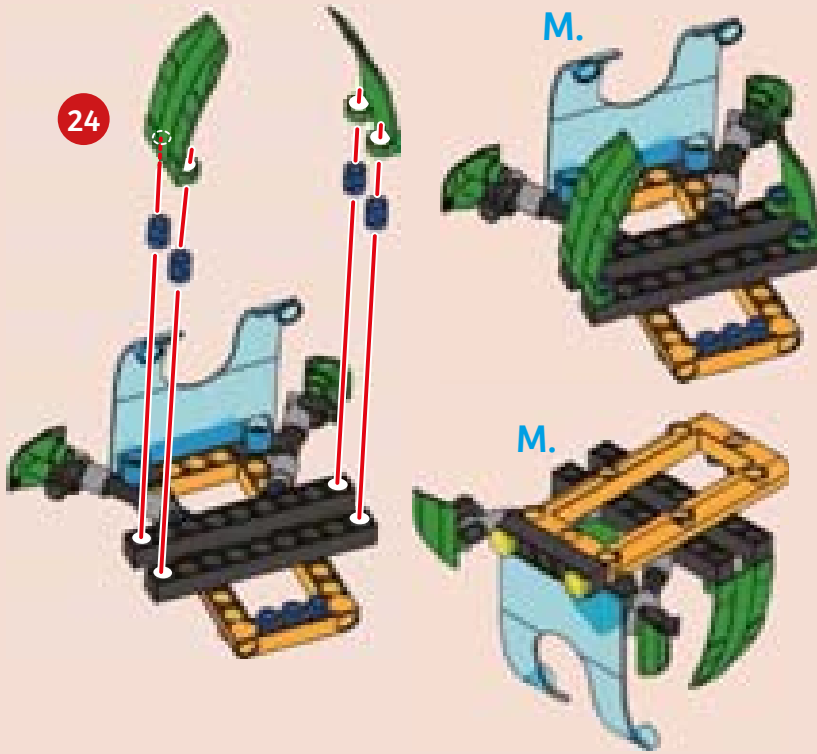



COMBINE HARVESTER

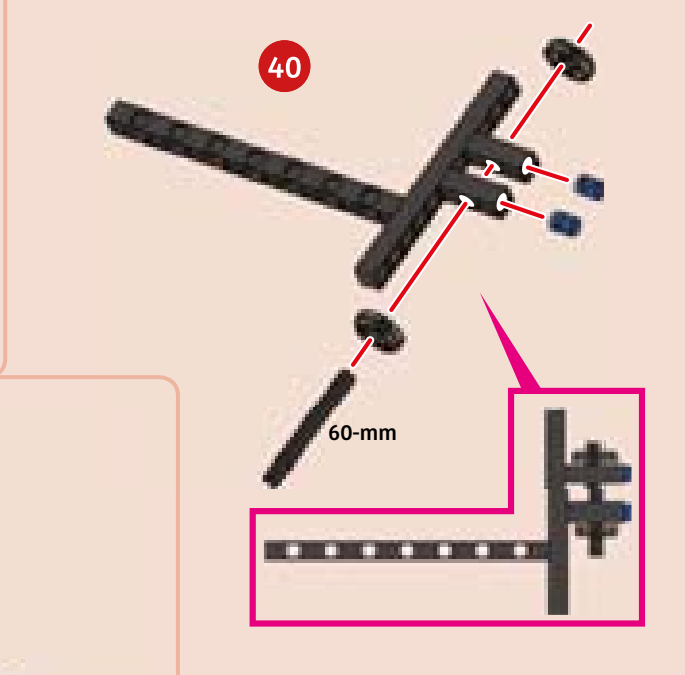
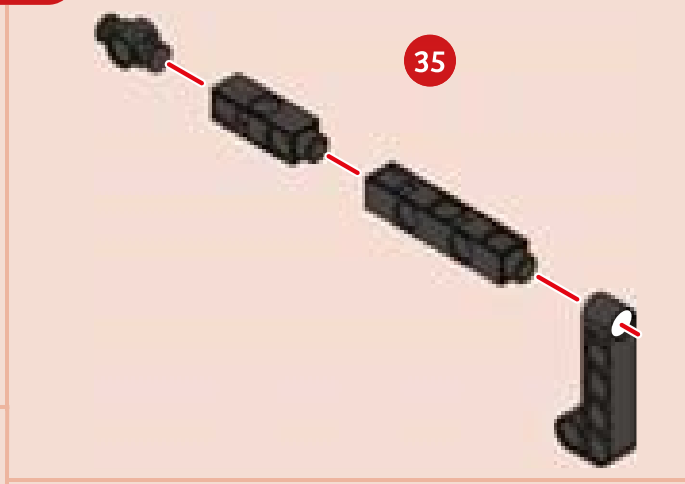
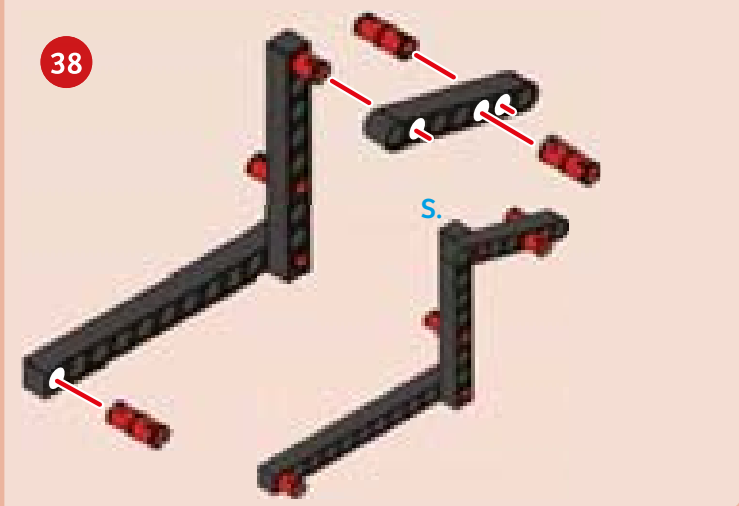
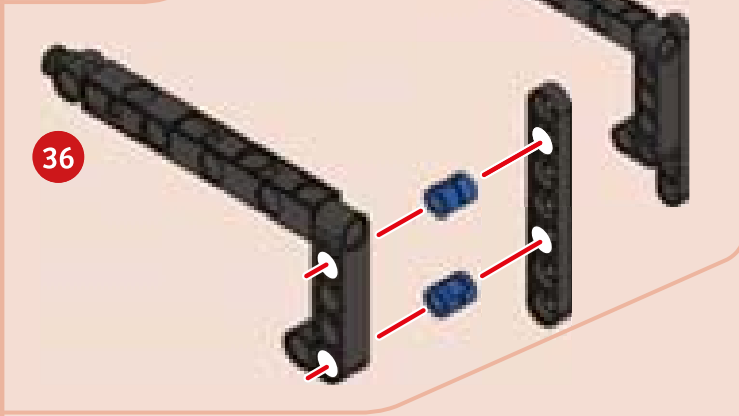
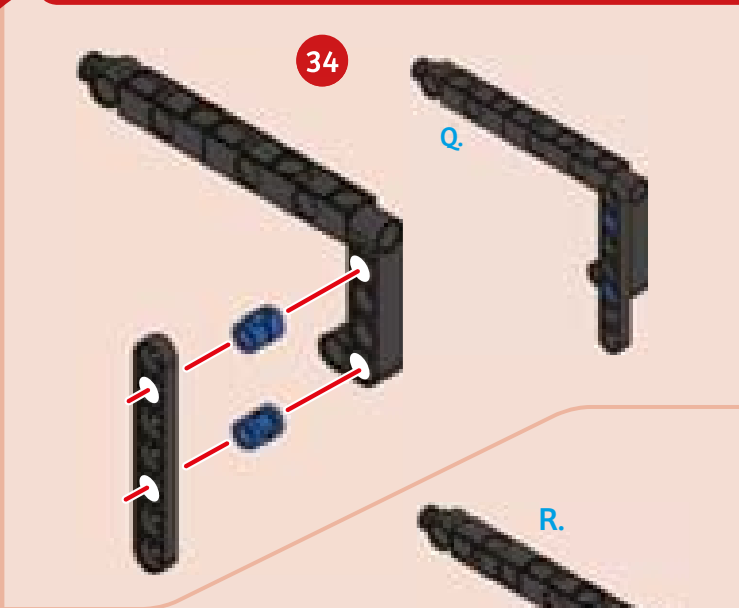

TIP!
Note the gear direction.

42

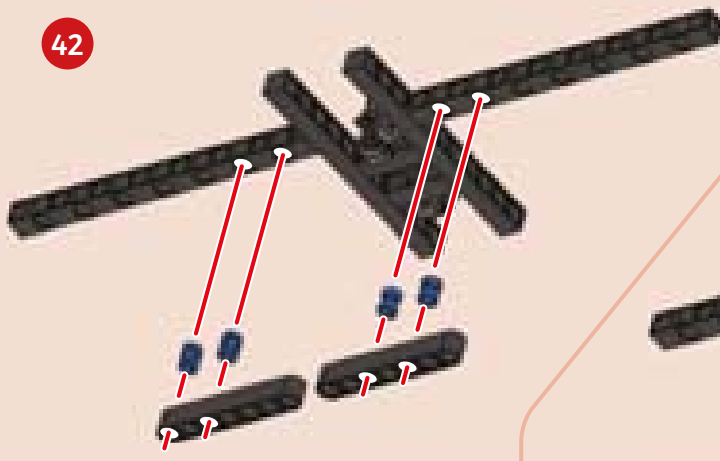

43

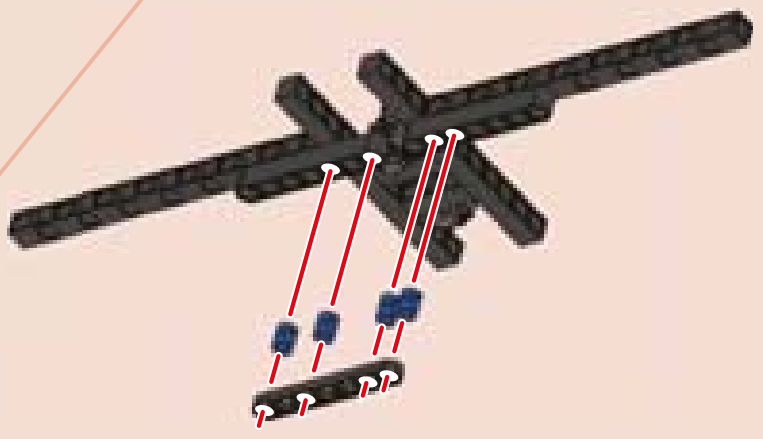

44

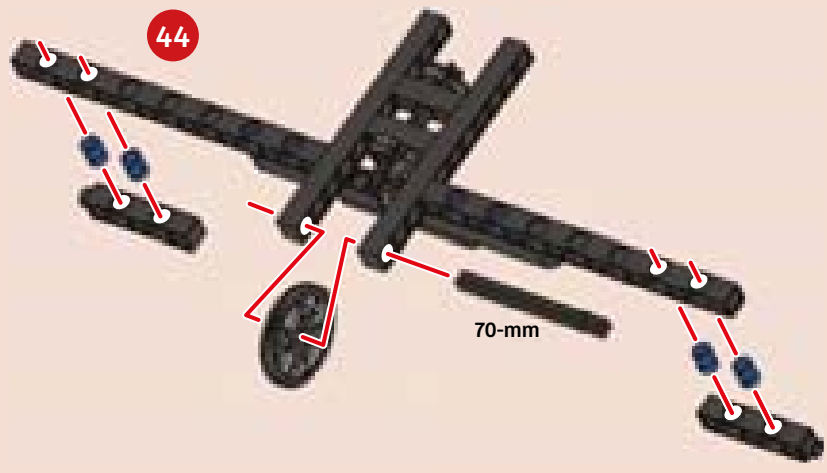

45

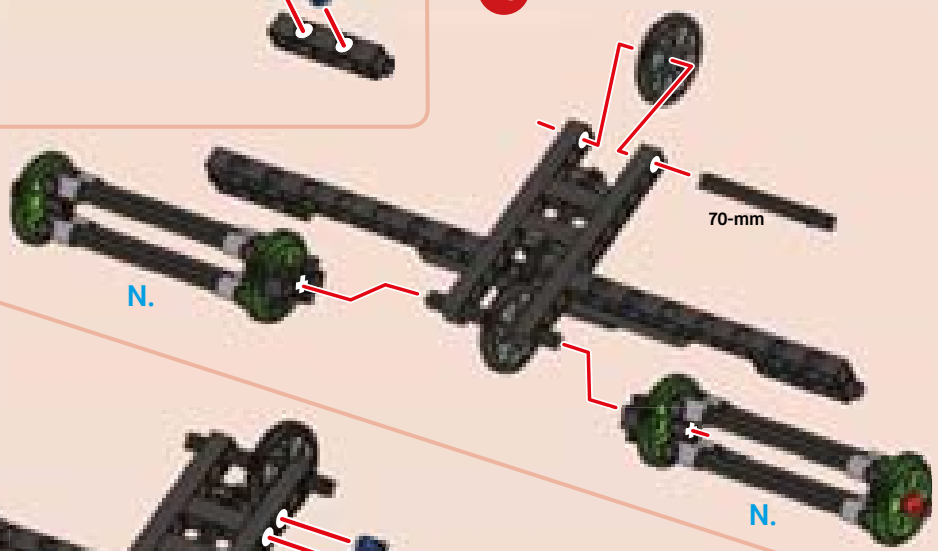

46

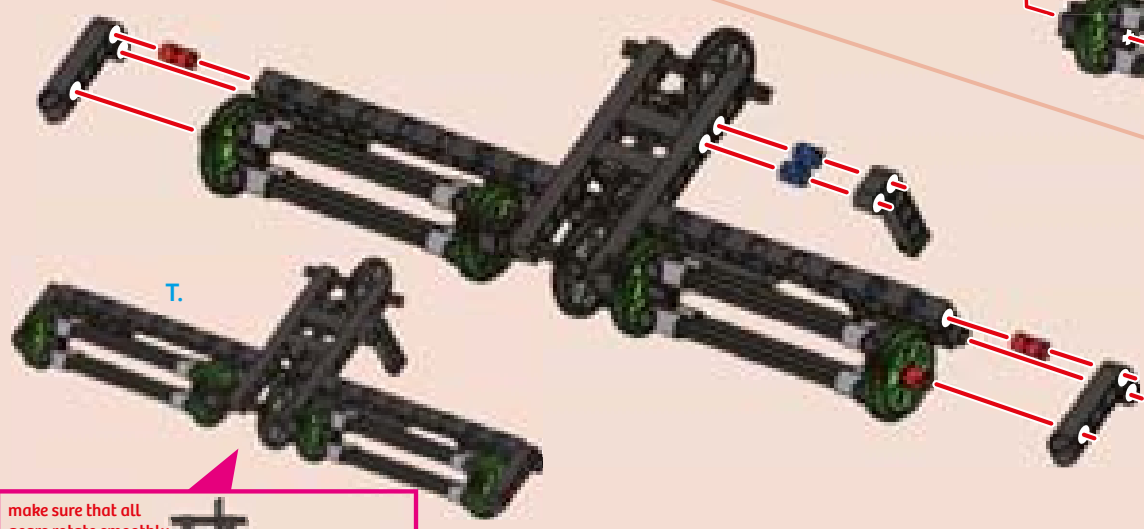

make sure that all gears rotate smoothly



COMBINE HARVESTER

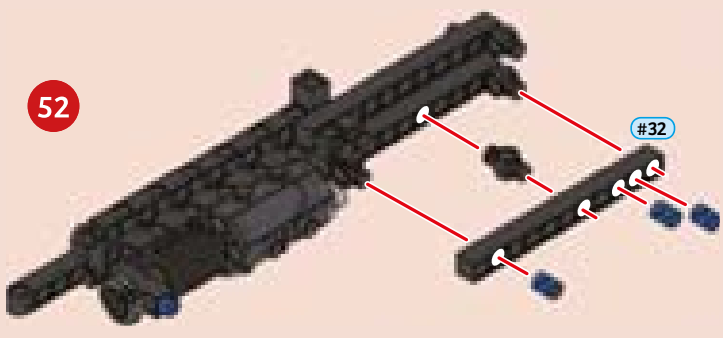
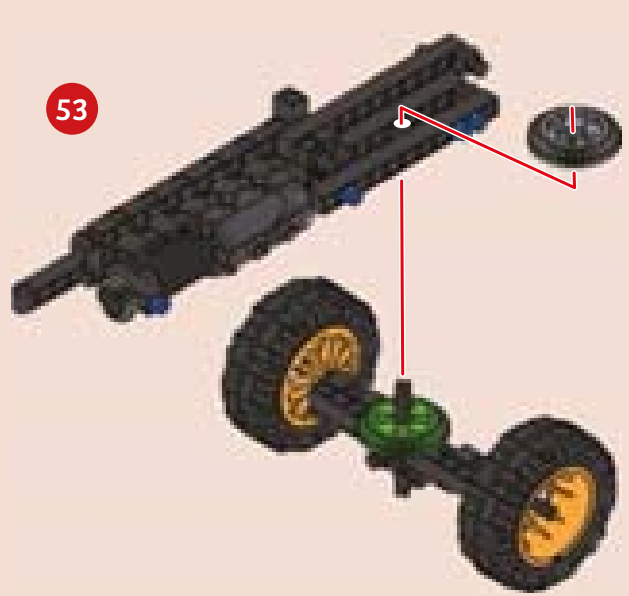
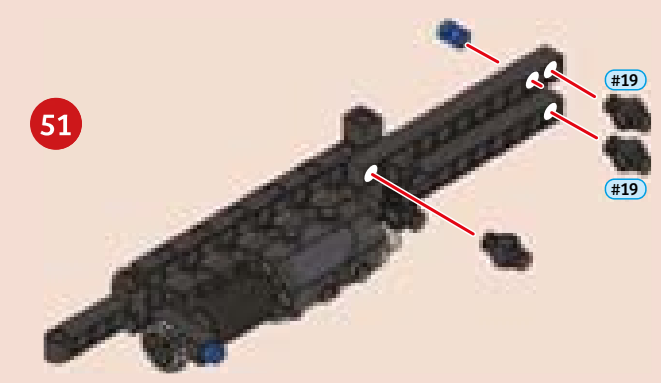
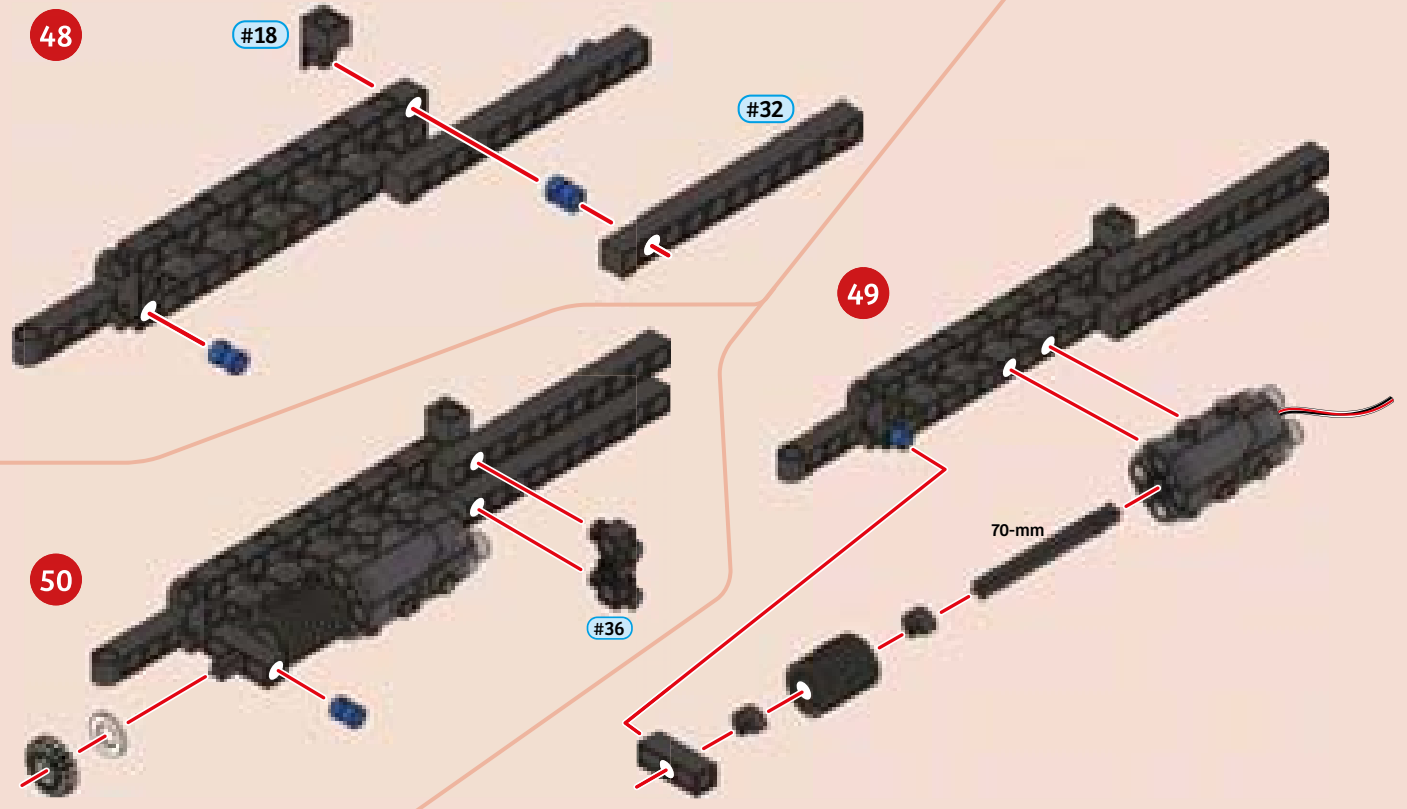
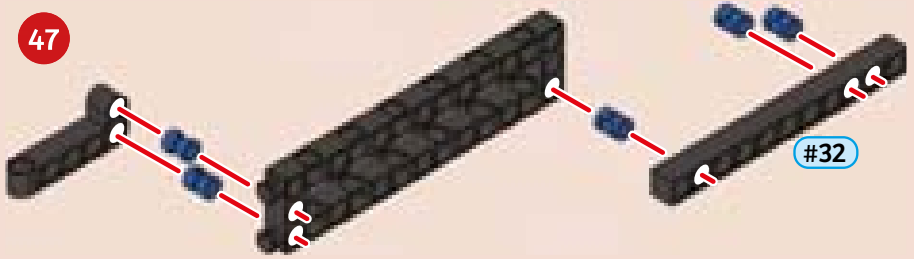

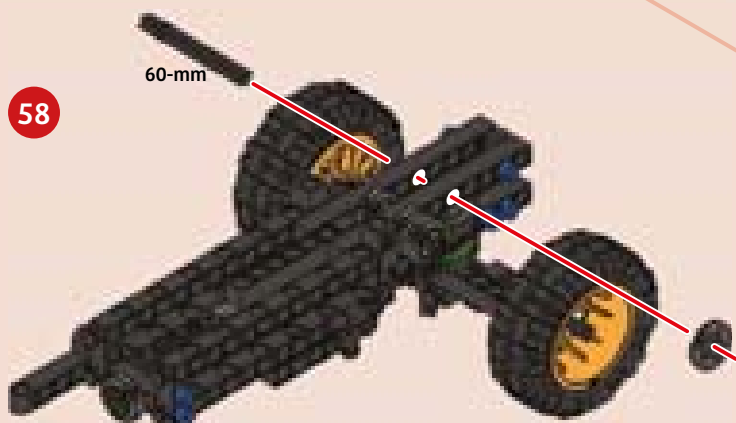
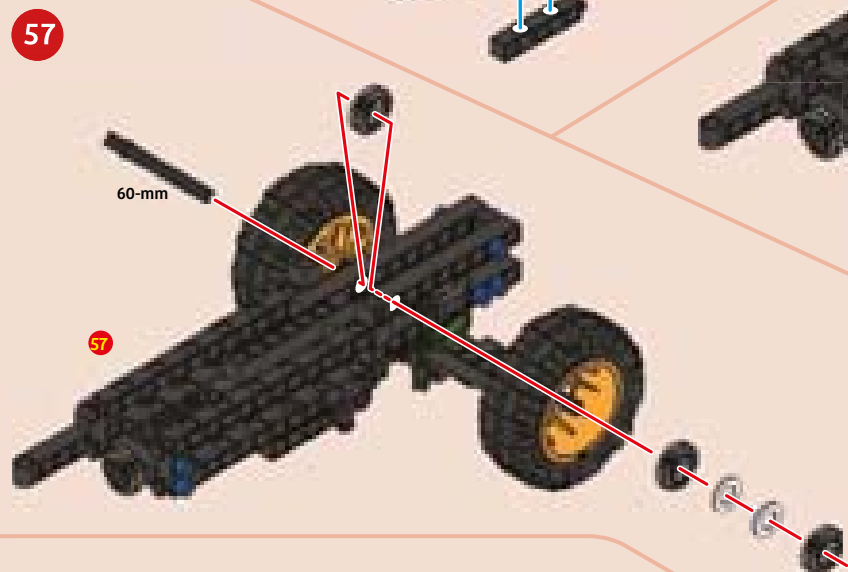
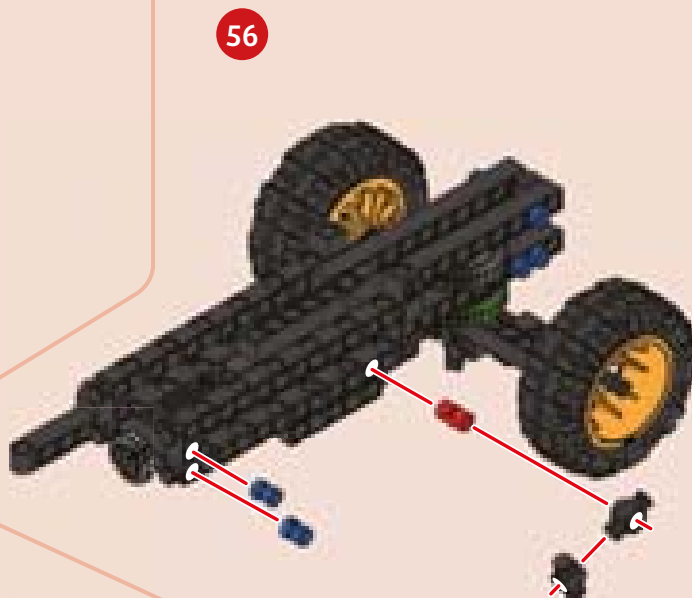
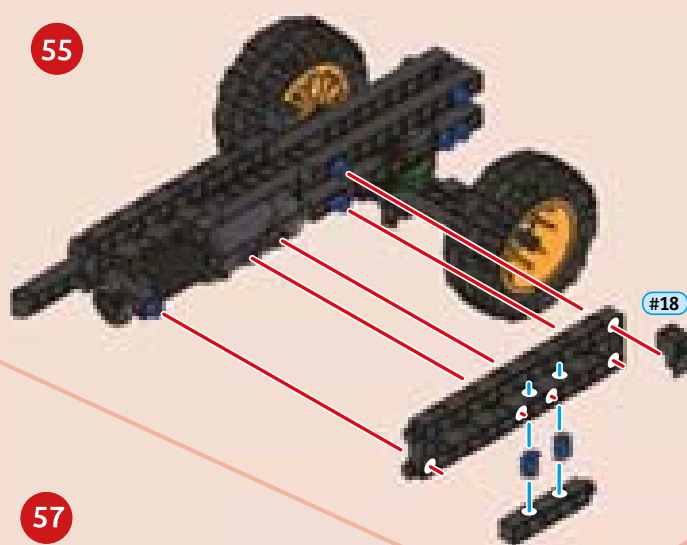
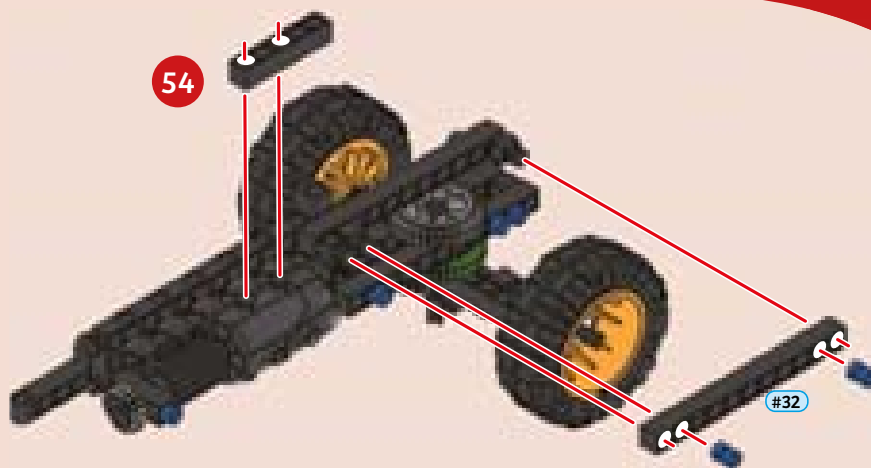

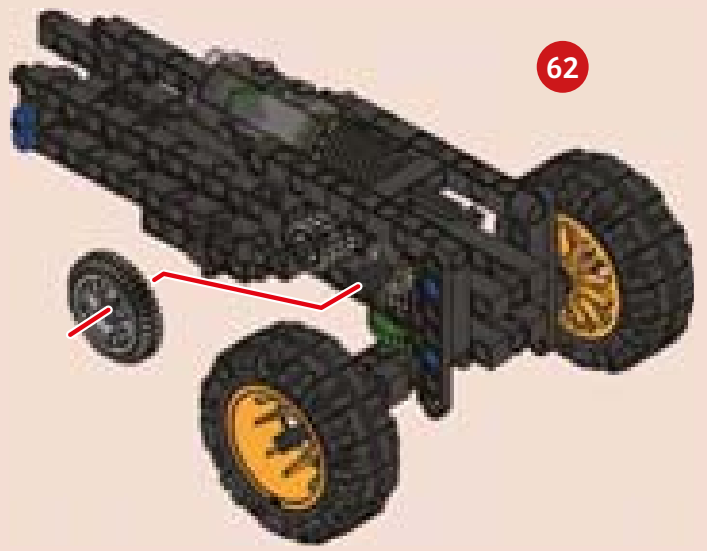
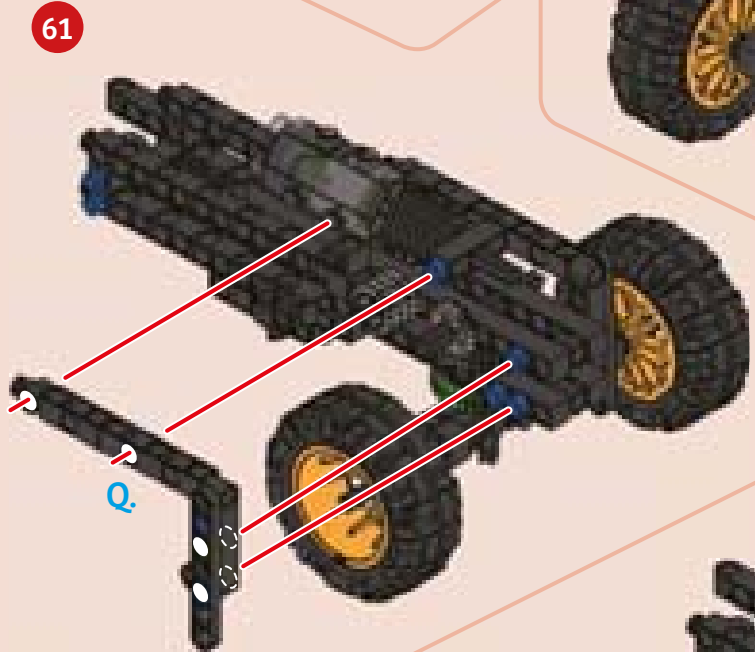
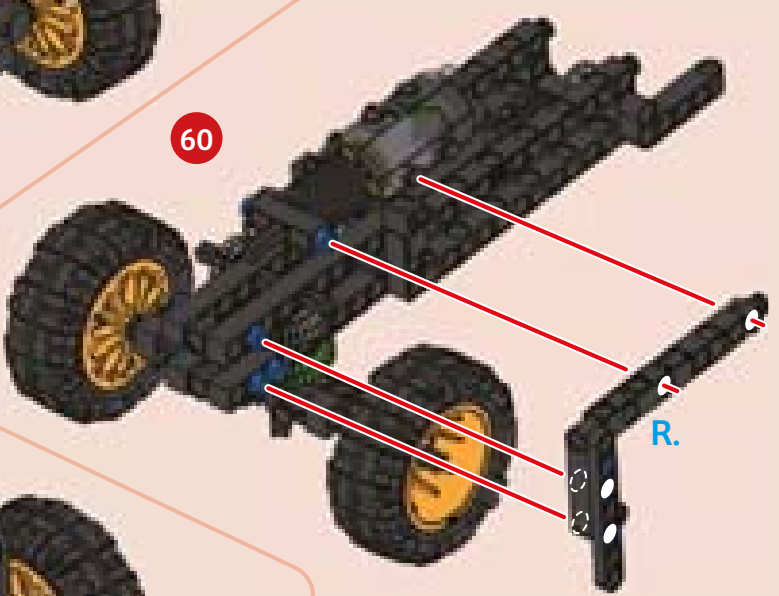
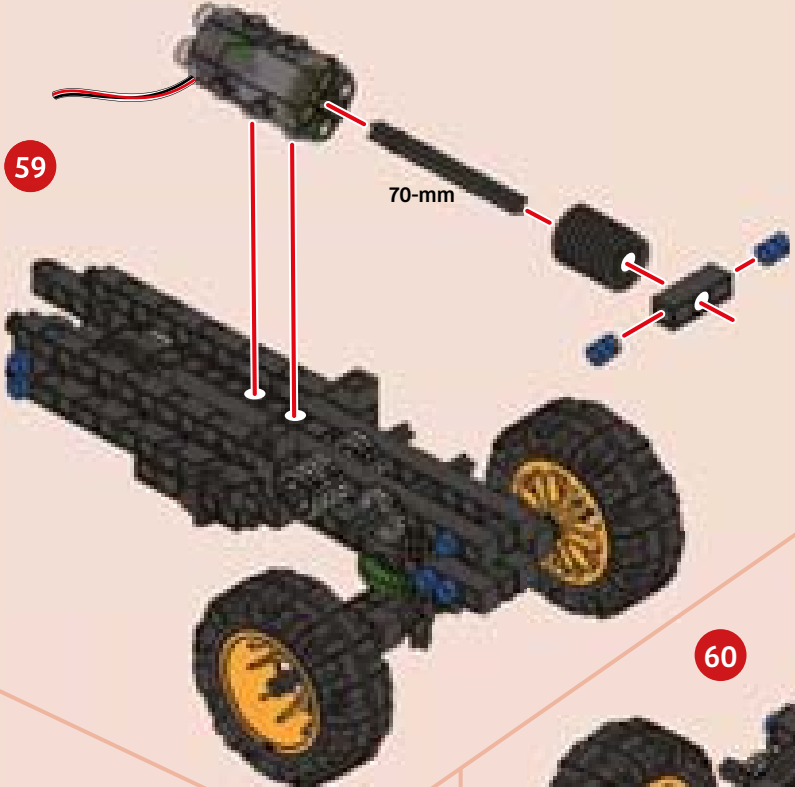

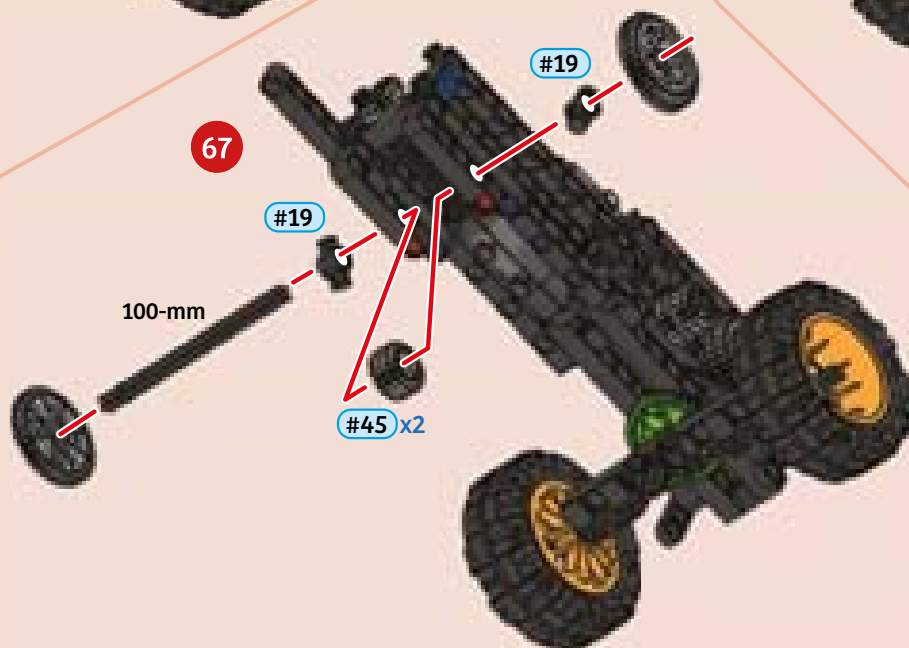
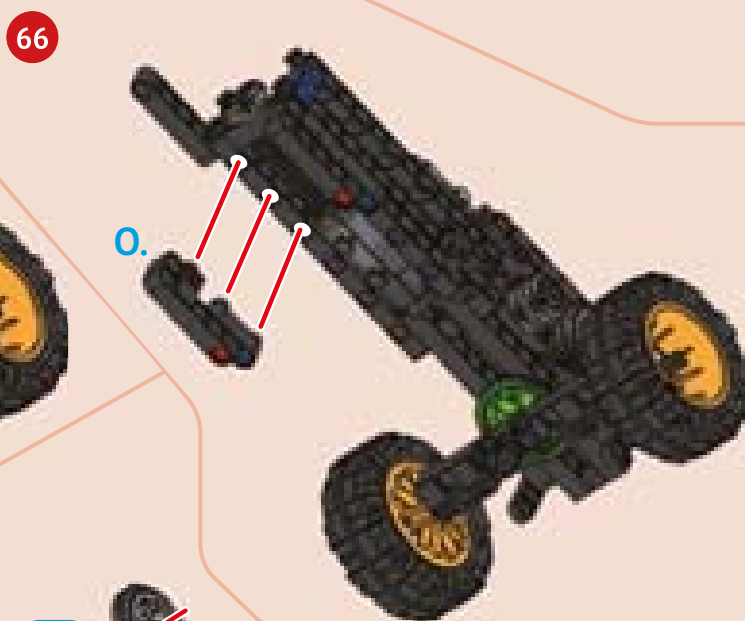
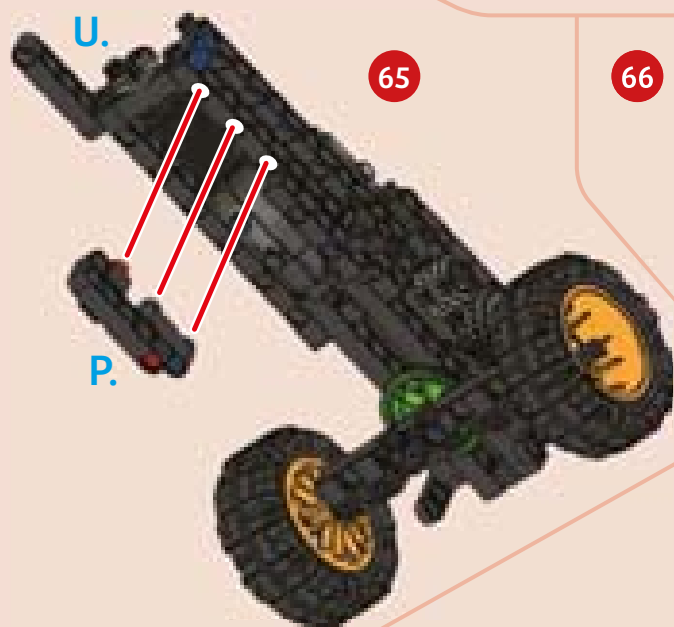
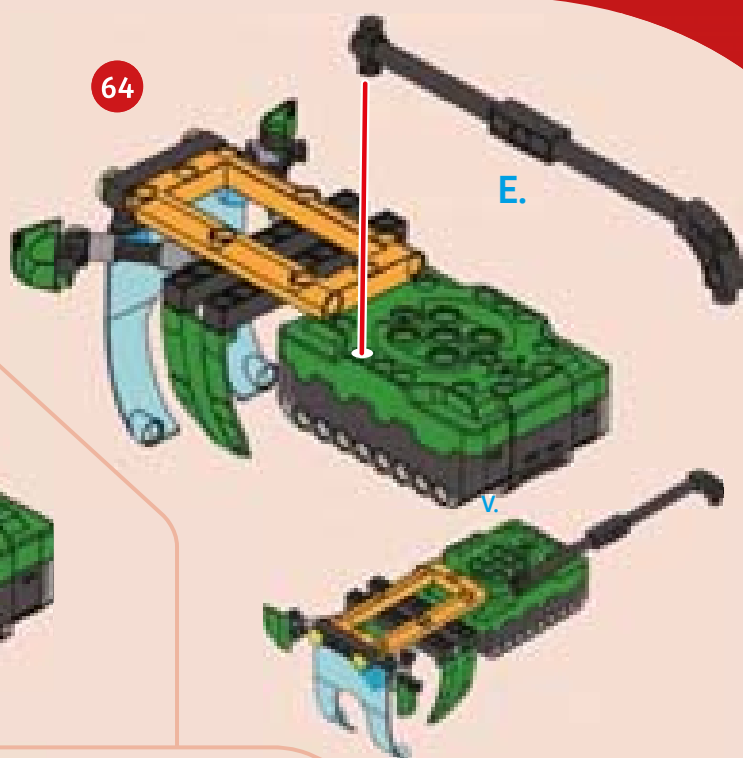
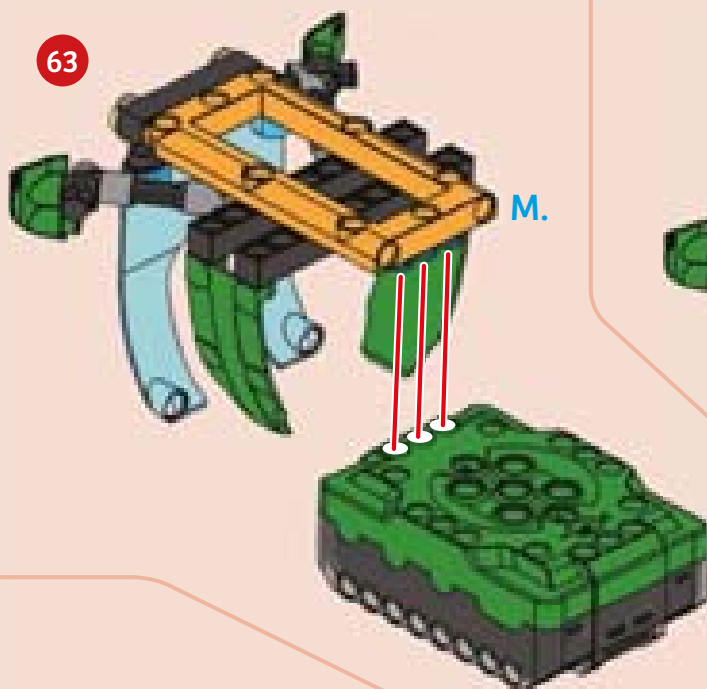



68

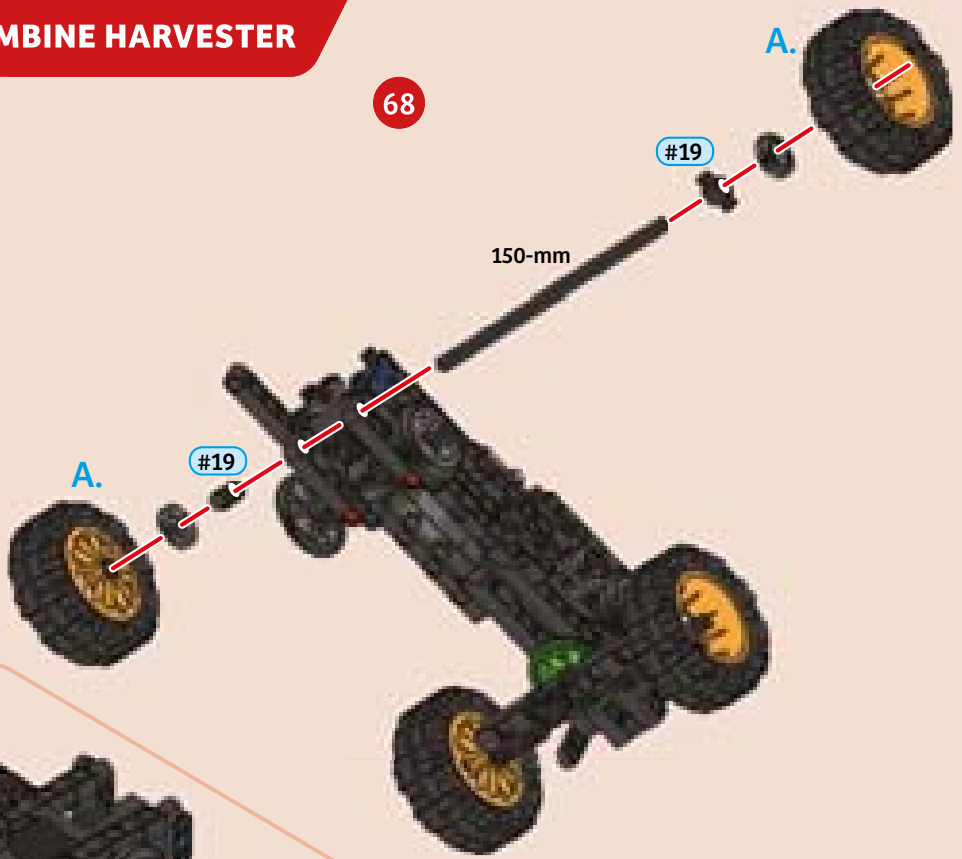

69

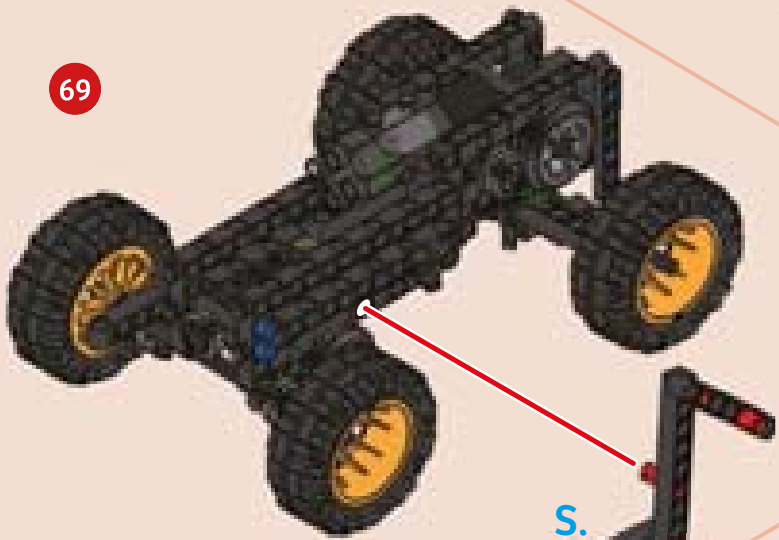

70

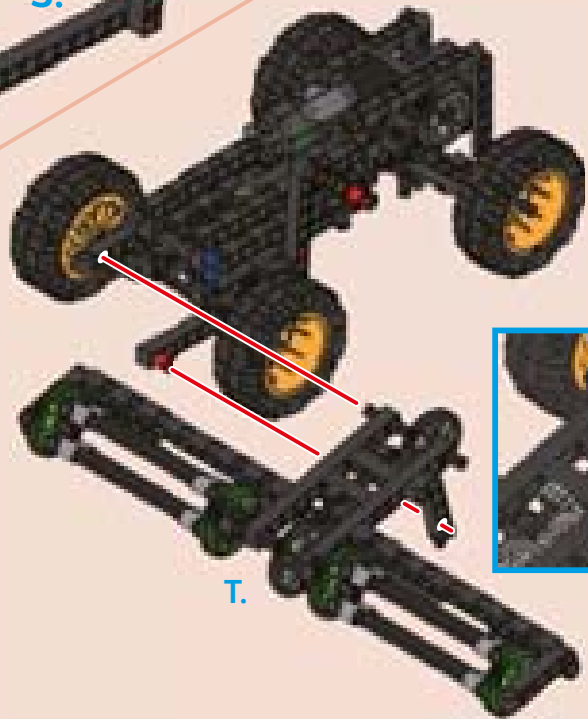

71

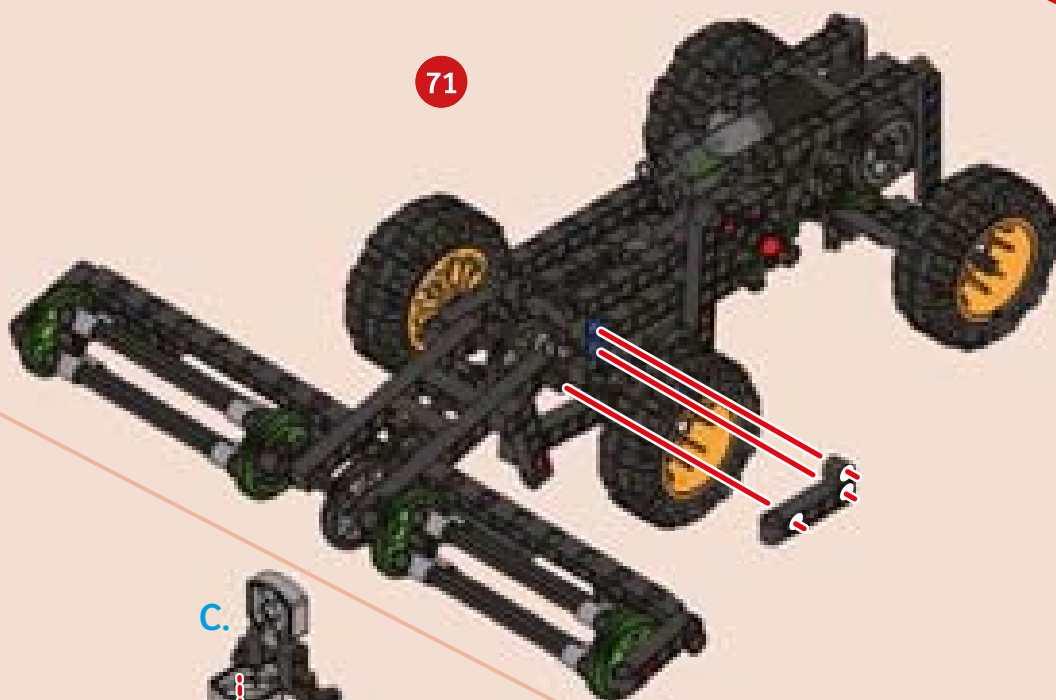

72

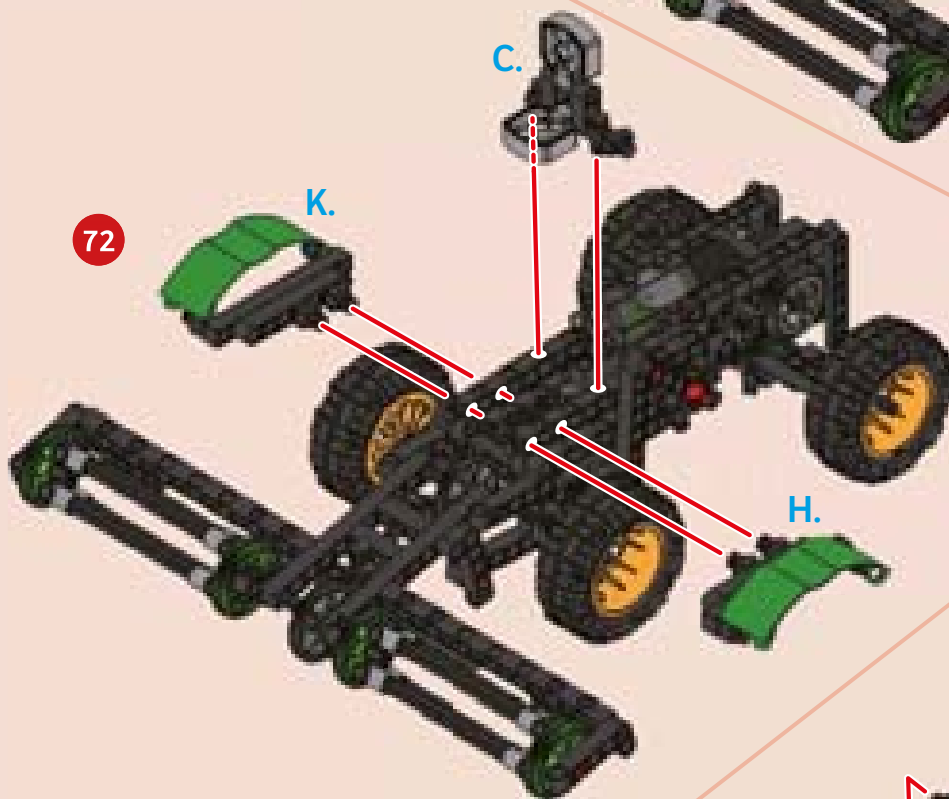

73

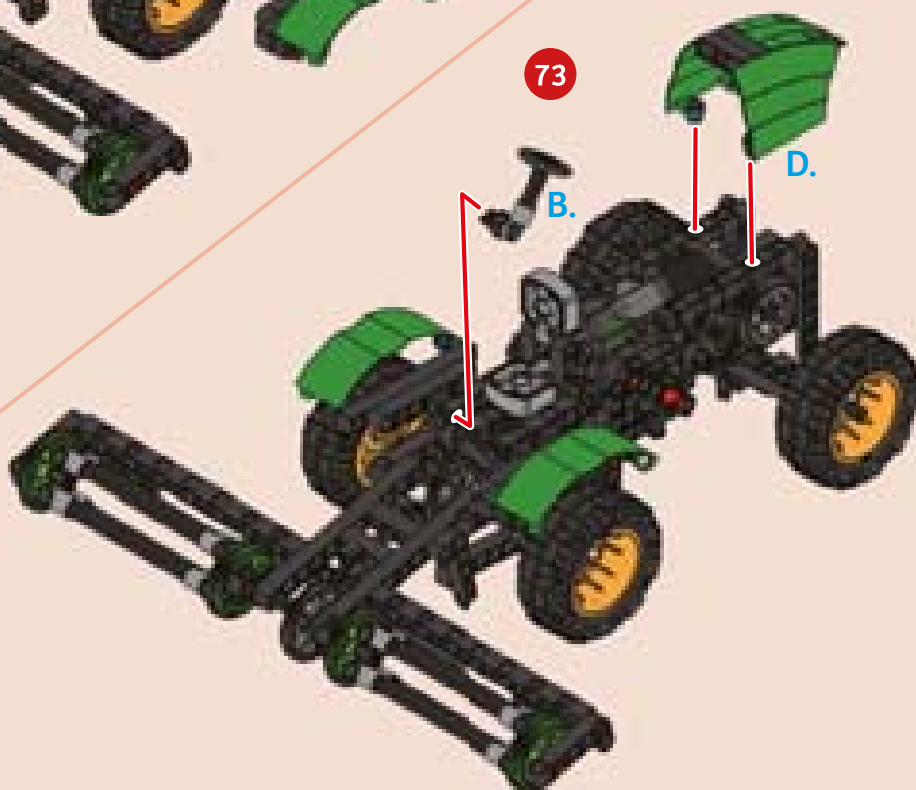



74

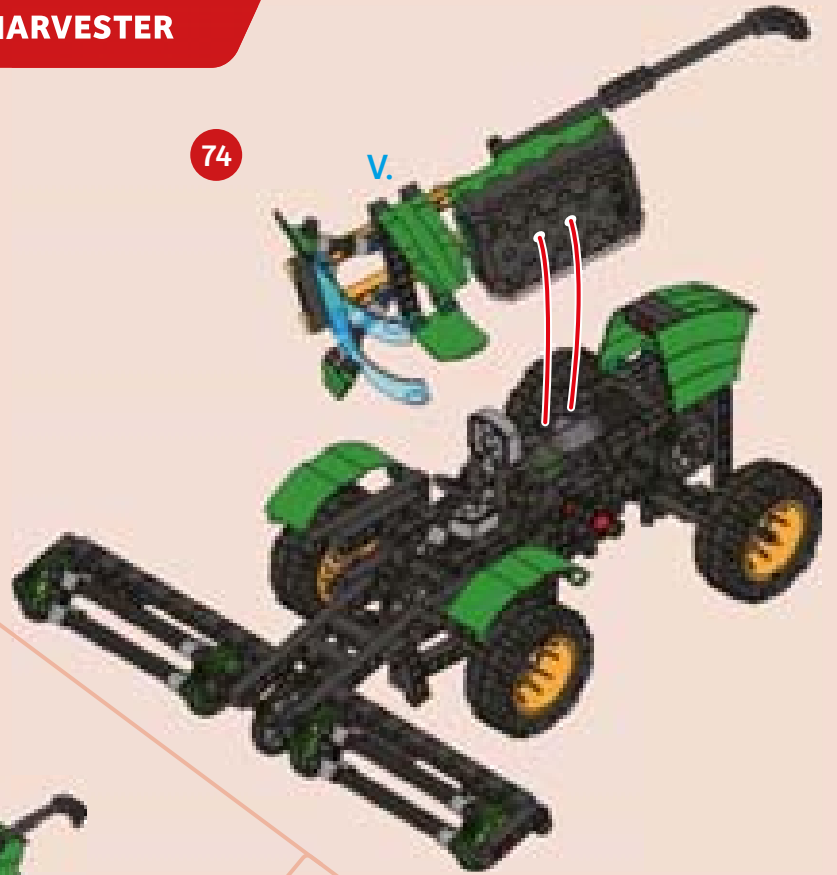

75

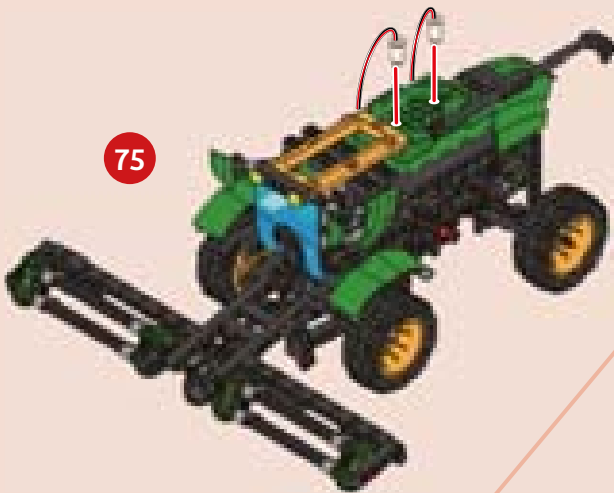

Pulling up on the joint pin will make the head move down.



Pulling down on the joint pin will make the head move up.

EXPERIMENT 5

Reaping grass

HERE'S HOW

Have the combine harvester go through a small patch of dry grass with the front of the combine harvester down. What do you observe happens to the grass at the front of the combine harvester as it goes over it.

76

Done!

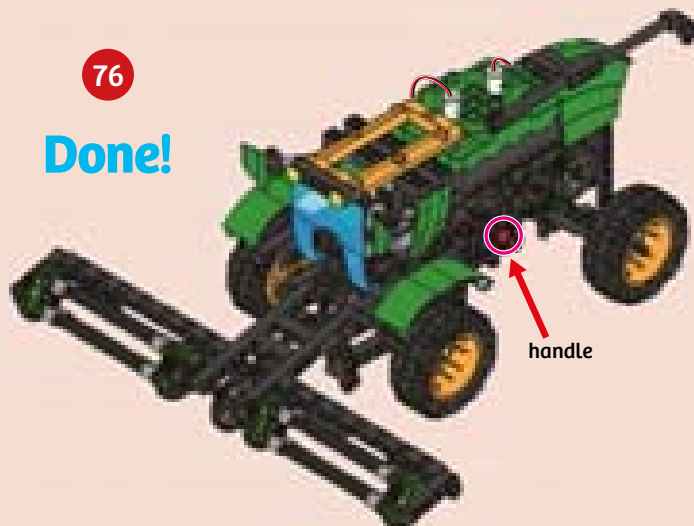

CHANGING THE GEAR RATIO

1

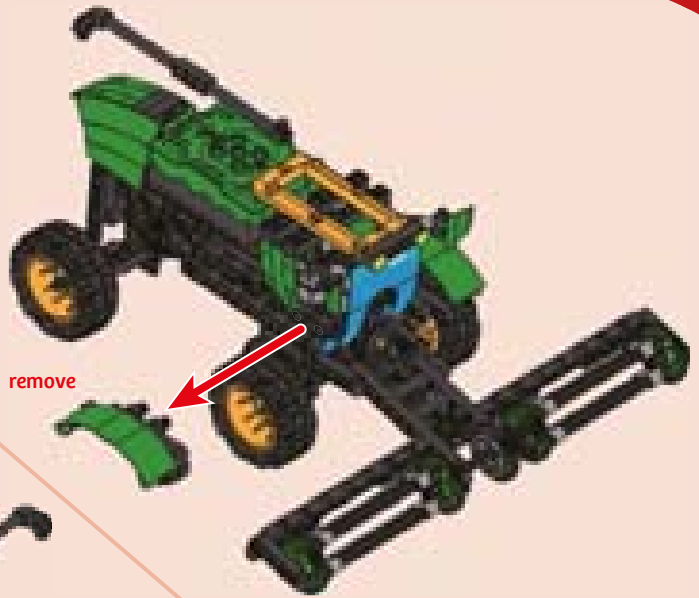

2

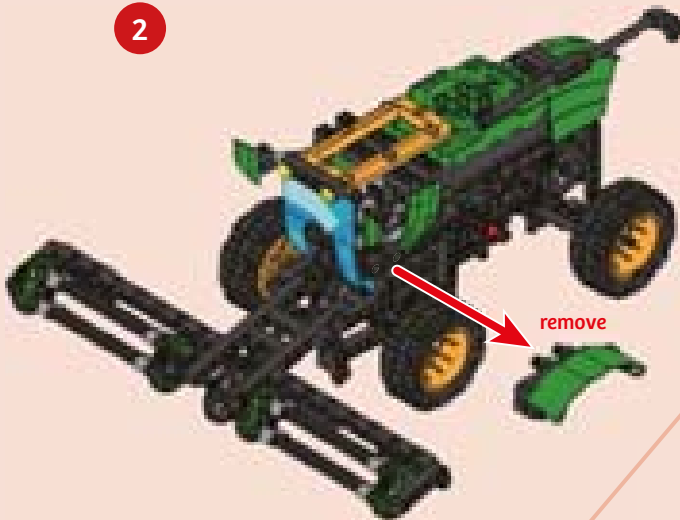

3

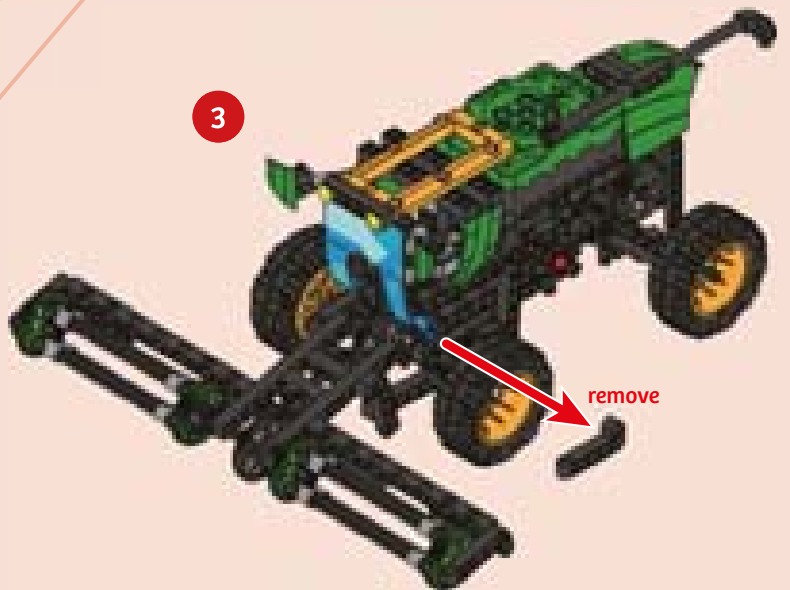

4

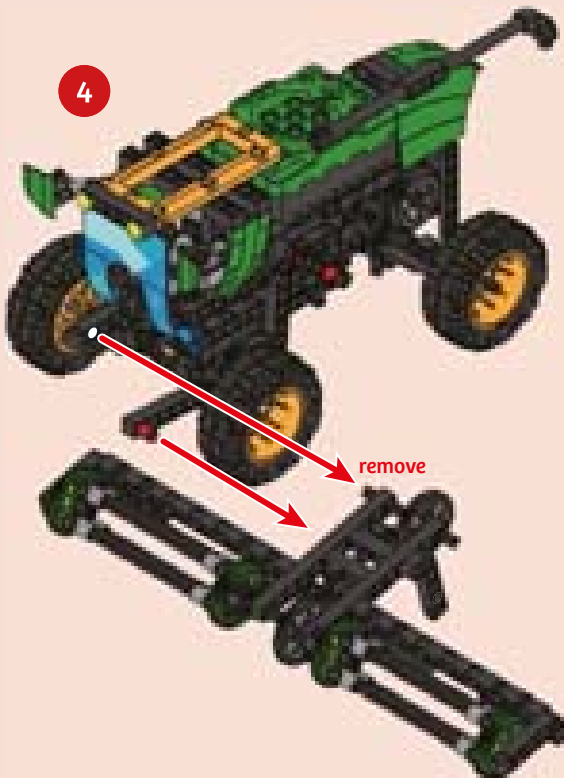



COMBINE HARVESTER

5



6

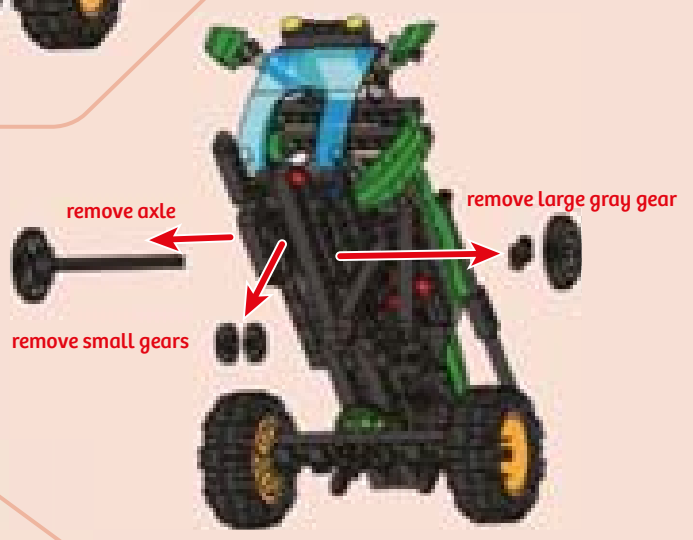

7



8

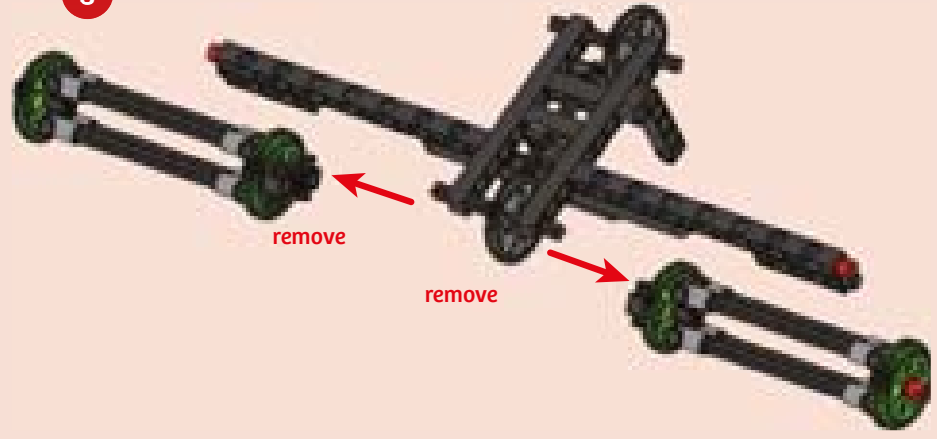

9

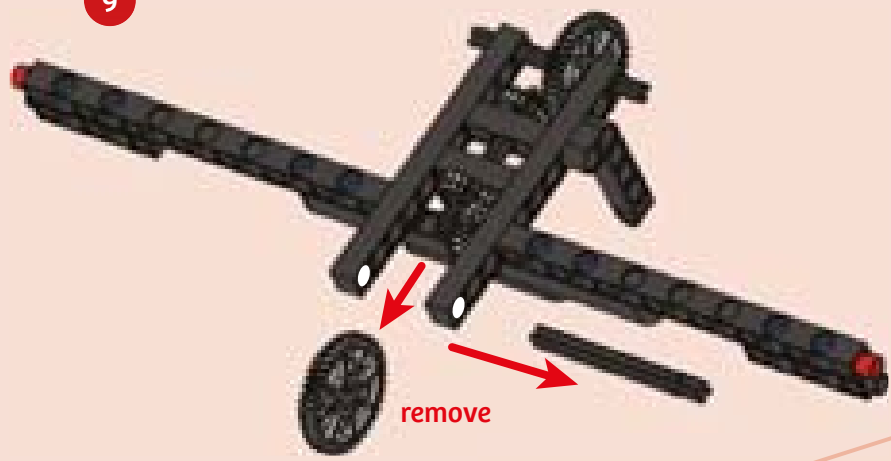

10

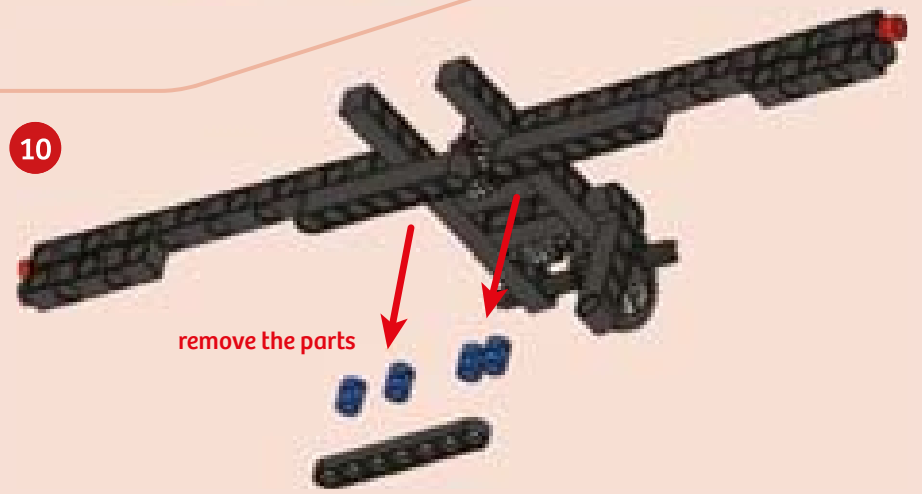

11



12

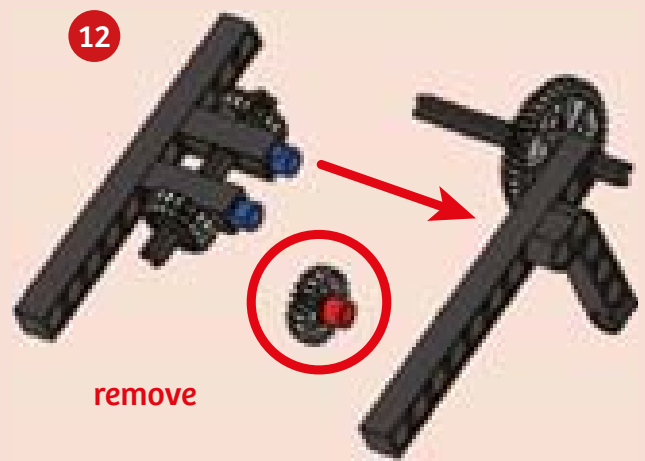

13

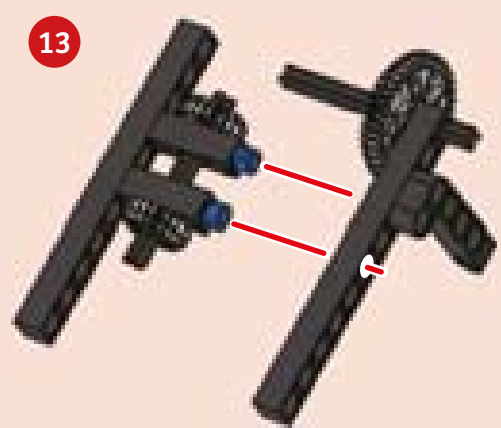



COMBINE HARVESTER

14

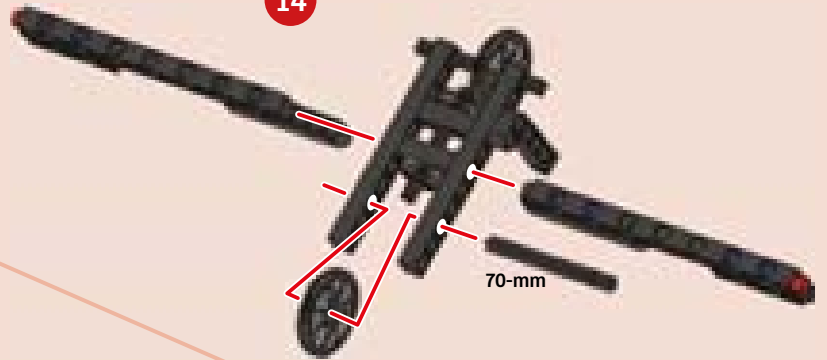

70-mm

15

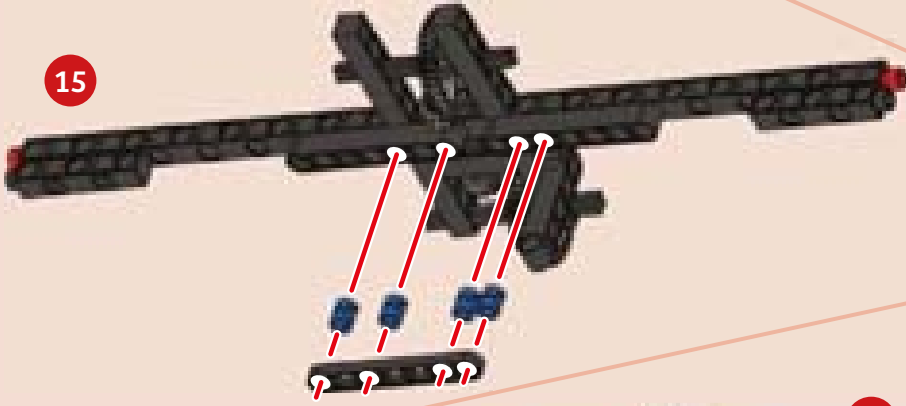

16

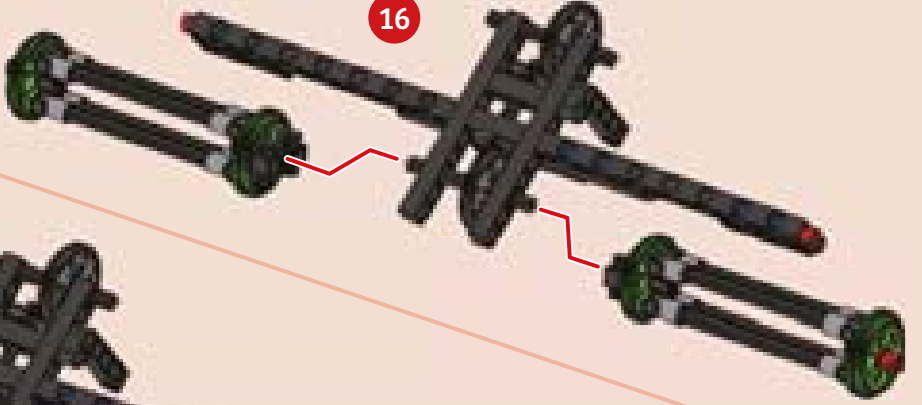

17

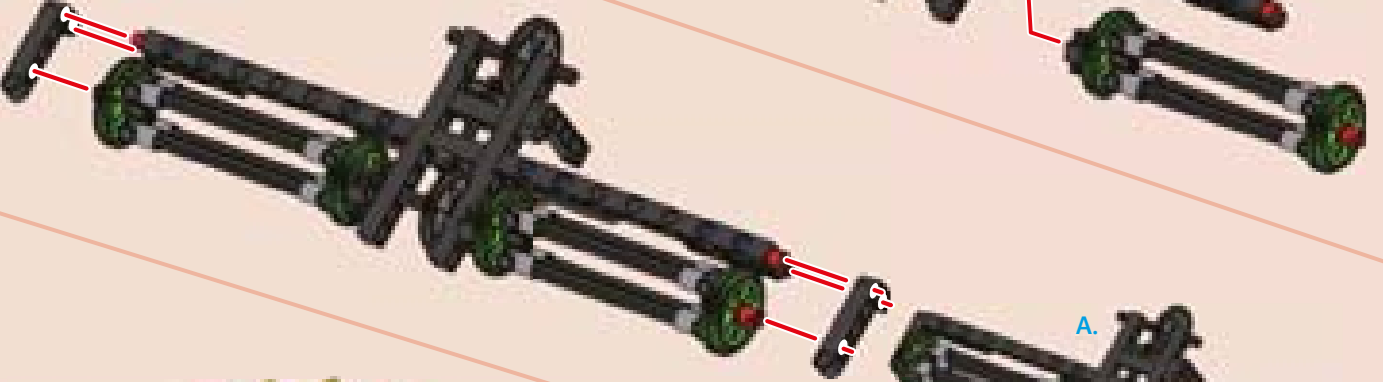

A.

18

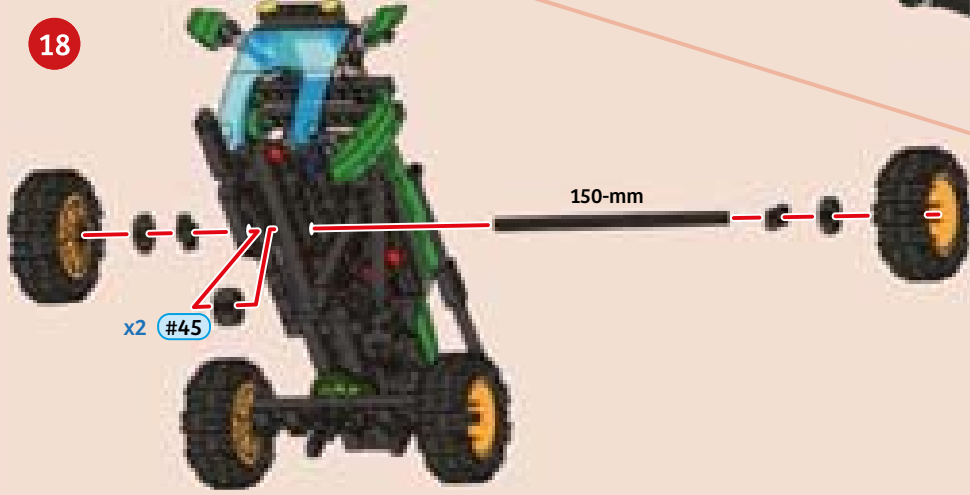

150-mm

x2 #45

Make that sure all the gears rotate smoothly.

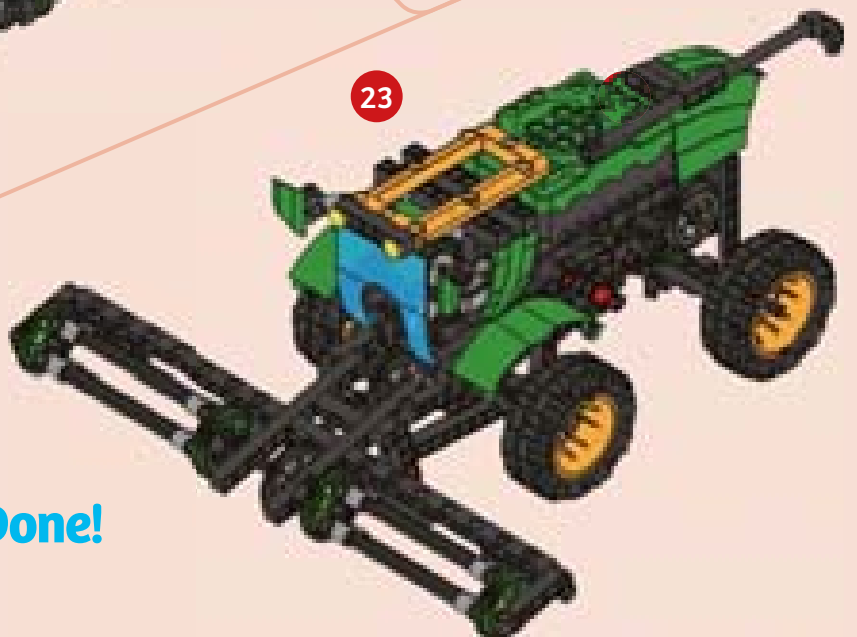
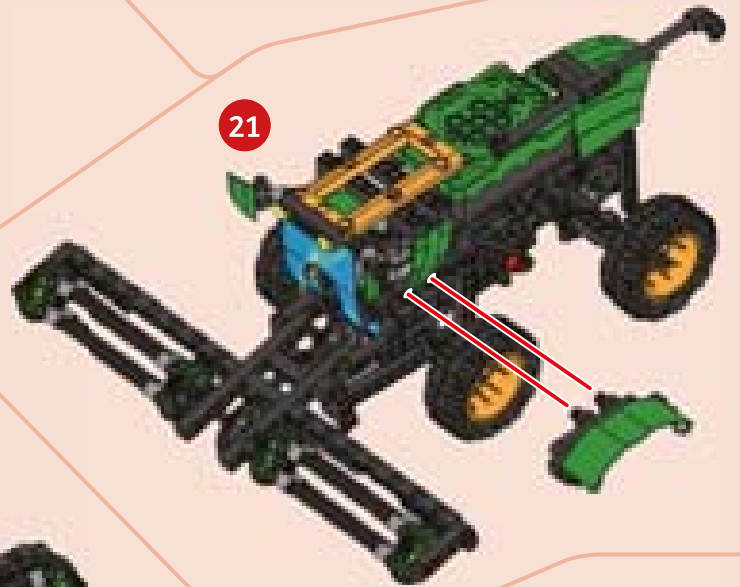
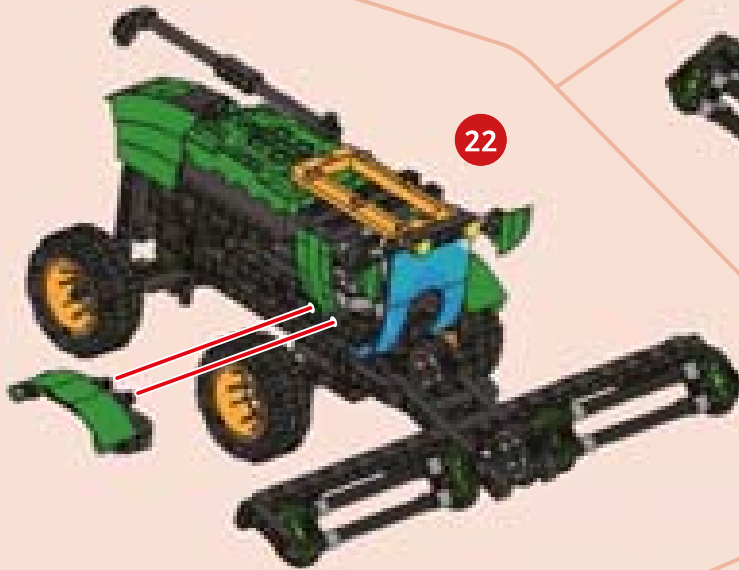
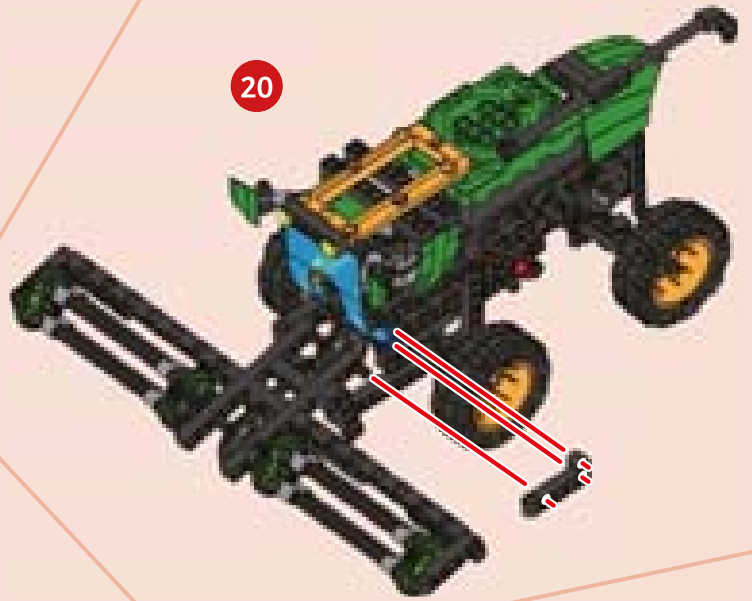
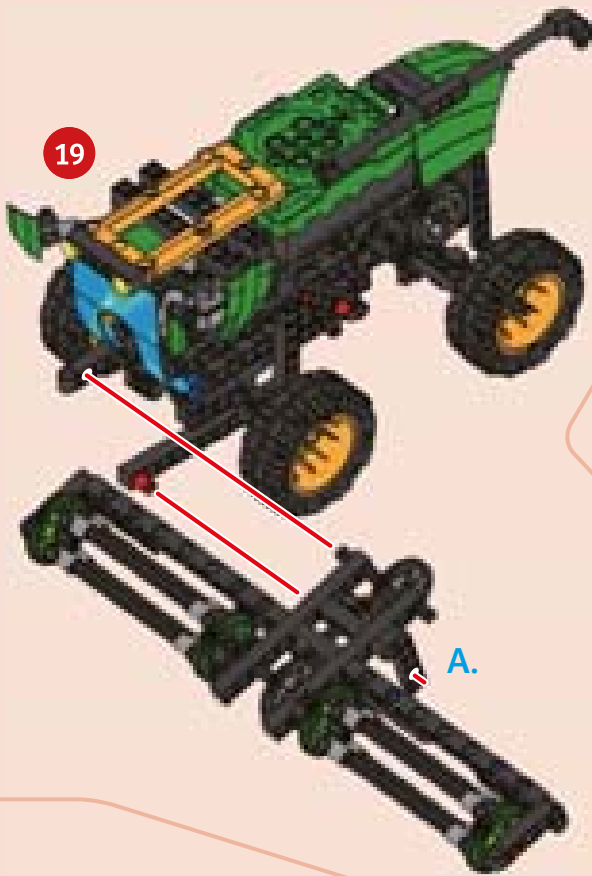

Done!



HOW A COMBINE HARVESTER WORKS

The edible **grain** portion of crops such as wheat, corn, barley, and rye are covered by an inedible casing called **chaff**. To use the grain it has to be separated from the chaff. Before the use of machines this was a very labor intensive process. The combine harvester gets its name because it combines three processes in preparing grain crops: **reaping, threshing, and winnowing**.



The first step in the process is to cut the grass when it is ripe, called **reaping**. At the front of the combine harvester is the **header**, which gathers the plants into the combine. Behind the header is the **cutter bar**, which functions like a giant electric razor and cuts the base of the plants.

The next step is to remove the head of the stalk and loosen the grain from the chaff by **threshing**, which is accomplished by hitting the grain against a surface. In a combine harvester this is done by the **threshing drum**. The threshing drum is a cylinder with large bars that hit the grain as the cylinder rotates at high speeds.

The grains is finally separated from the chaff by **winnowing**. Under the threshing drum the grain and the chaff move over a grate. Air is blown through the chaff and grain, and the heavier grain falls through the grate while the chaff is blown towards the back of the combine.



SIMPLE MACHINES: THE SCREW

Once the grain has been separated from the chaff it is stored in a tank in the combine. When the tank is full the grain is emptied into a trailer through a pipe called an **unloader**. Inside the pipe is a **screw or auger conveyor** which moves the grain up the tube. A screw is simply a spiral blade around a shaft. As the screw turns it pushes the grain up along the tube.



FARM TRUCK

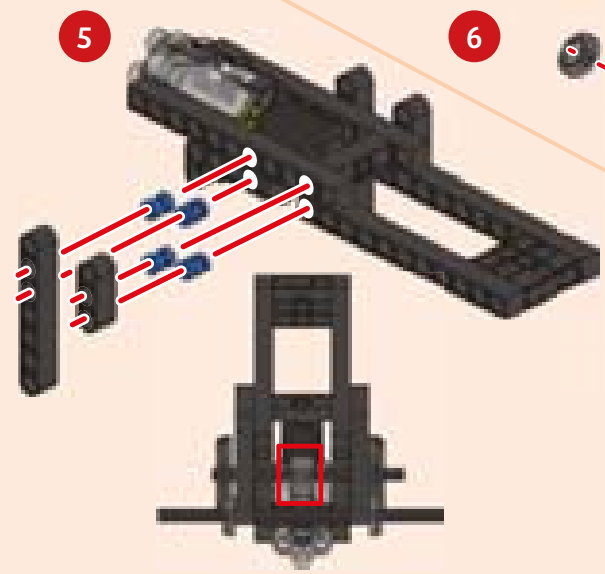
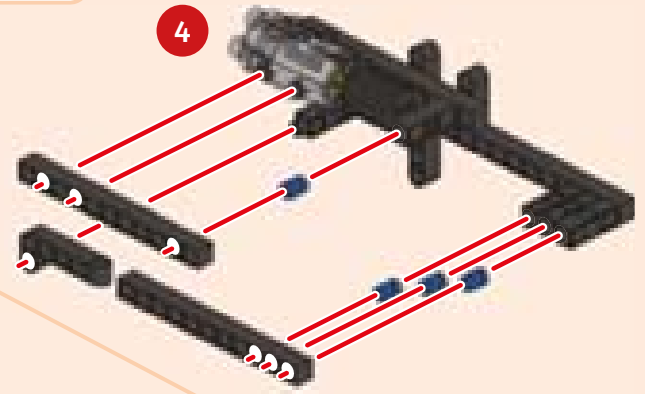
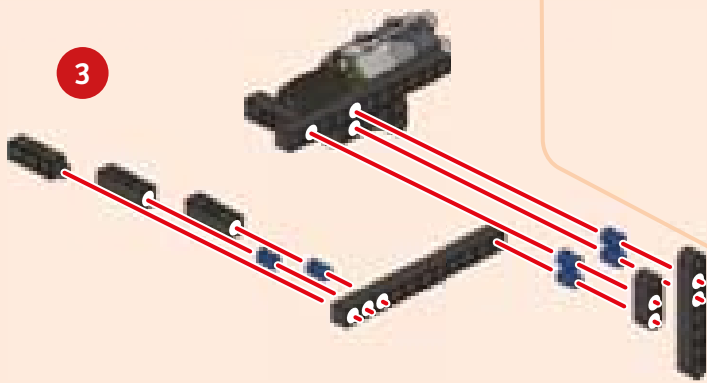
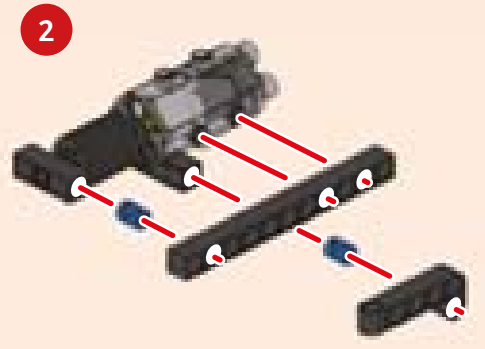
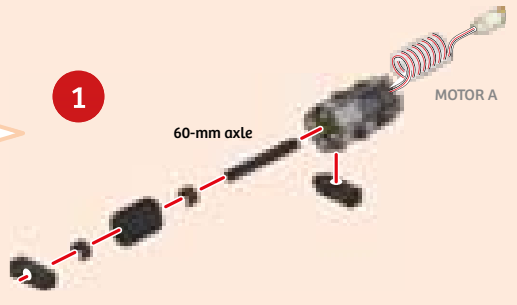
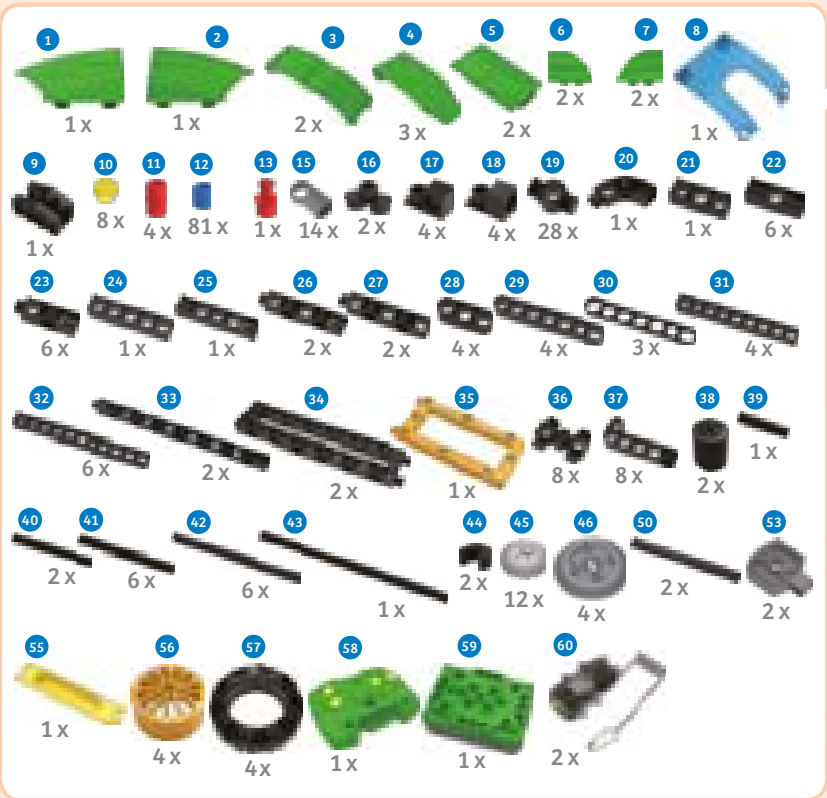

place the 20T gears in the middle

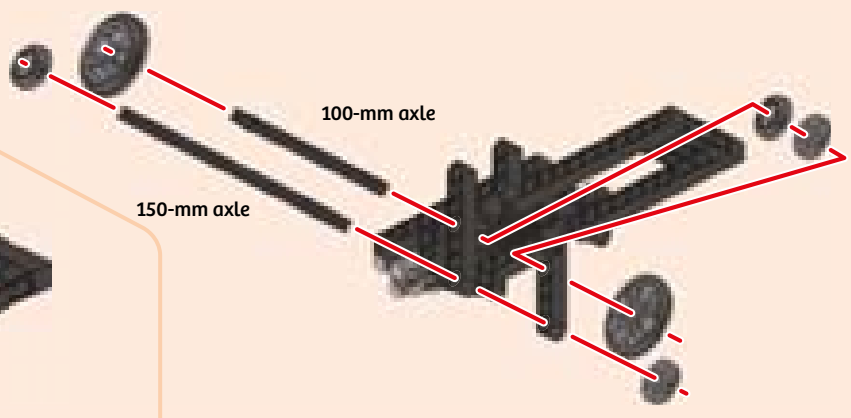



FARM TRUCK

7

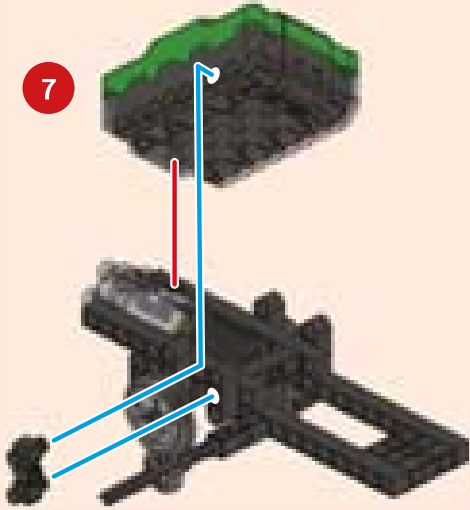

— FIRST
— SECOND

8

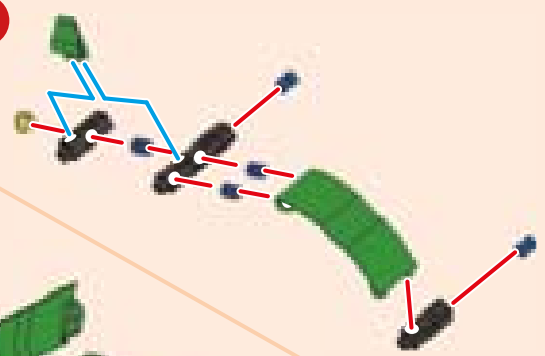

9

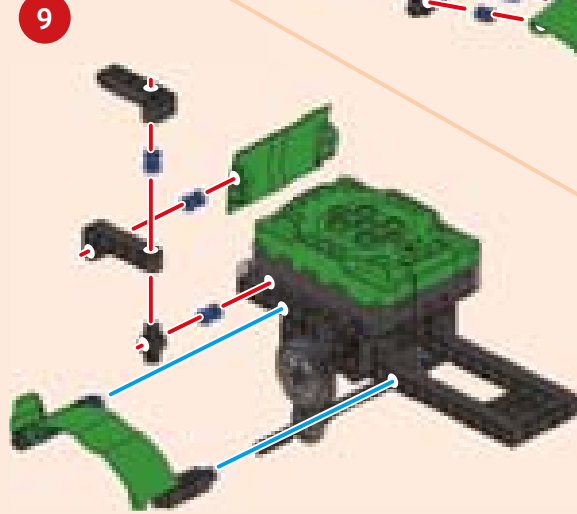

10

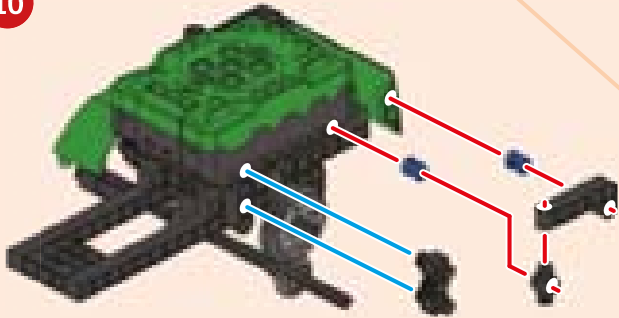

12

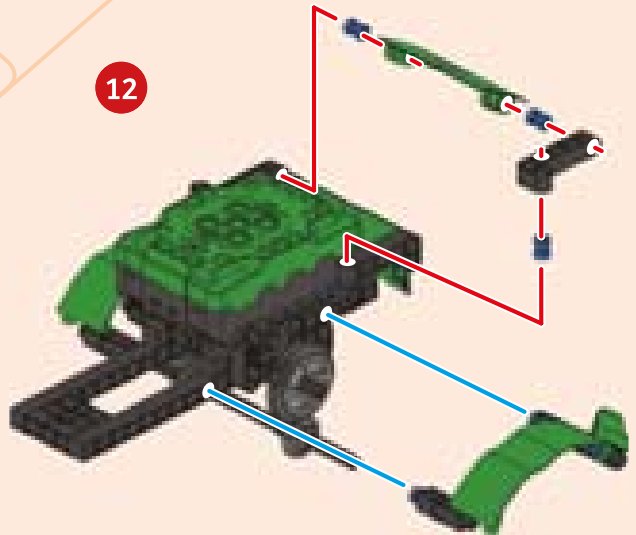

11

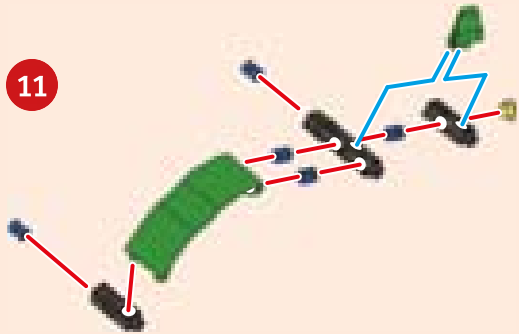

13

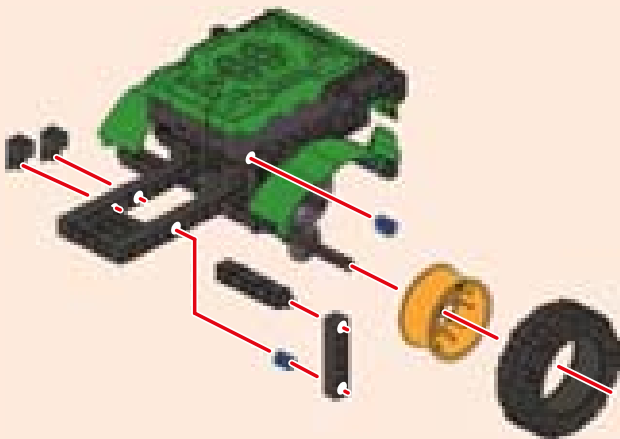

14

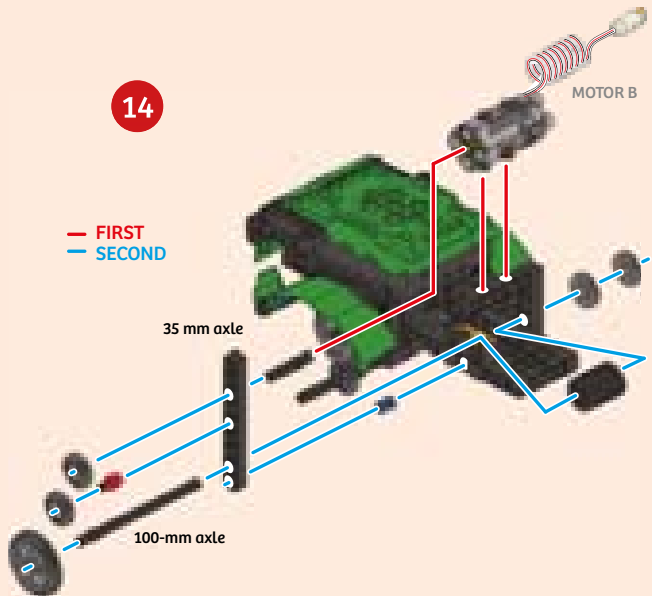

— FIRST
— SECOND

15

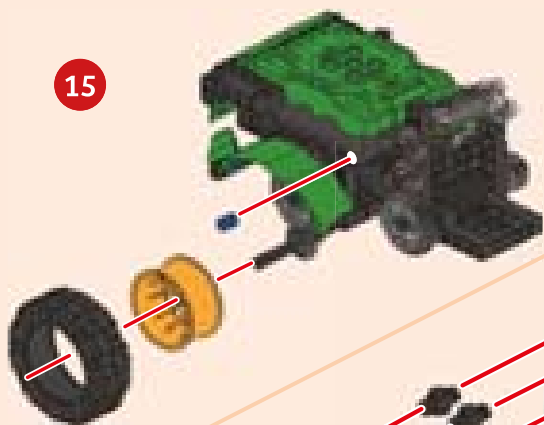

16

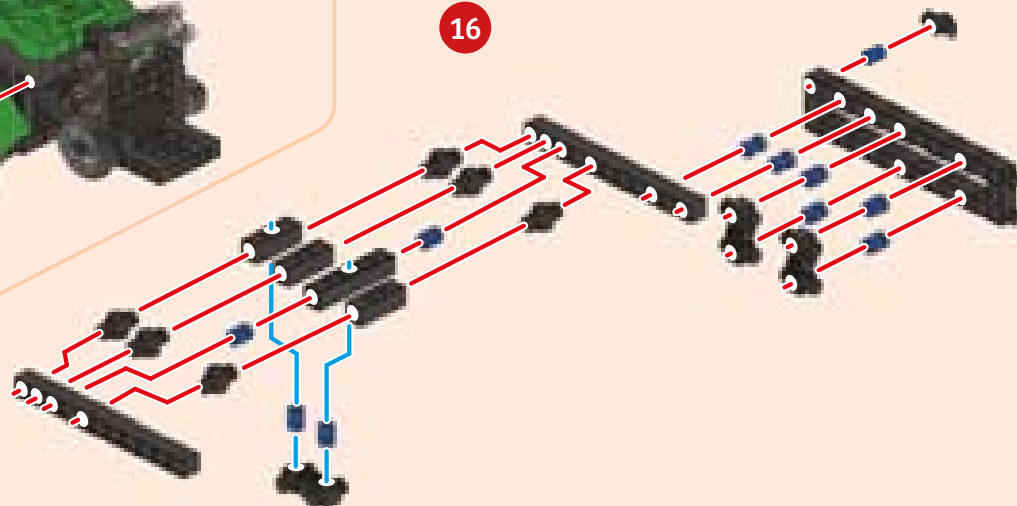

17

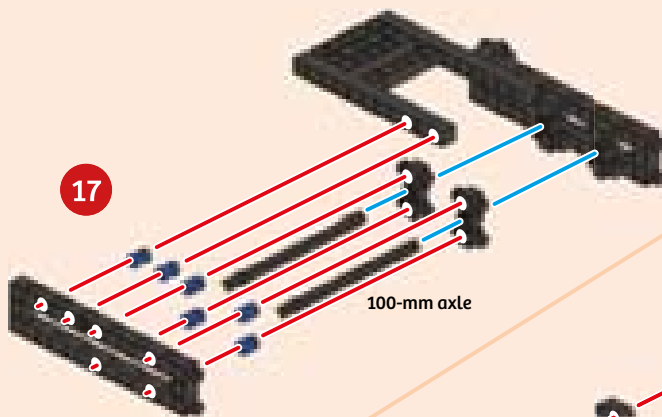

100-mm axle

18

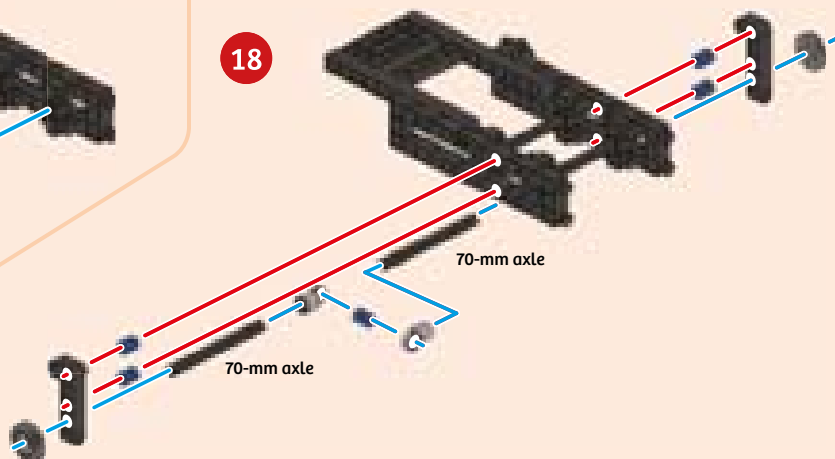

70-mm axle

70-mm axle

19

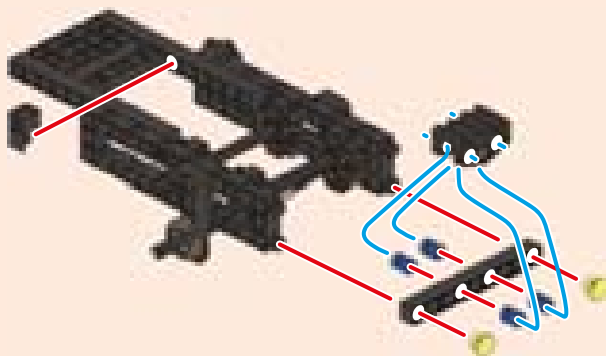

20

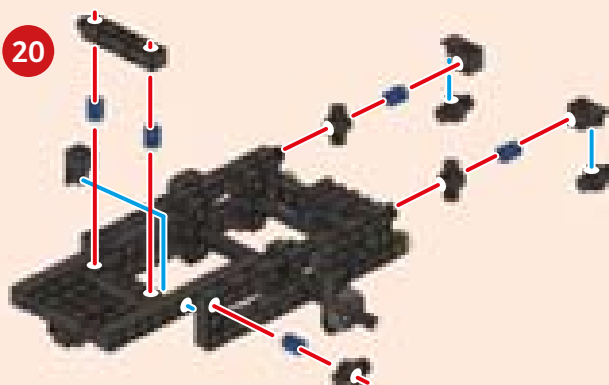

21

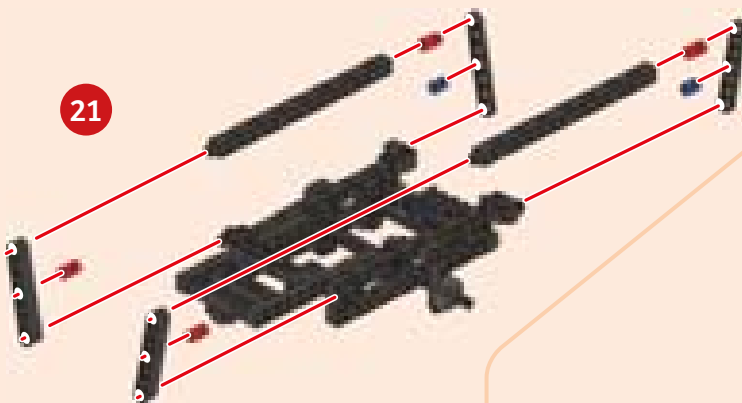

22

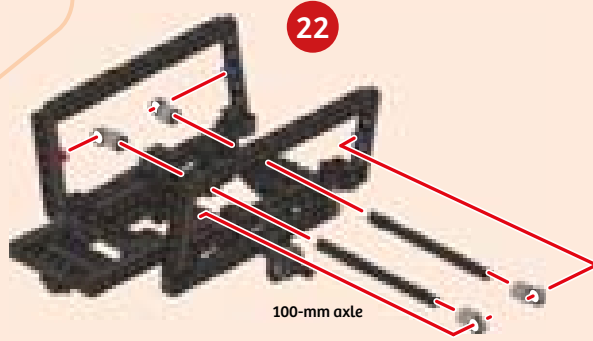

100-mm axle



FARM TRUCK

24

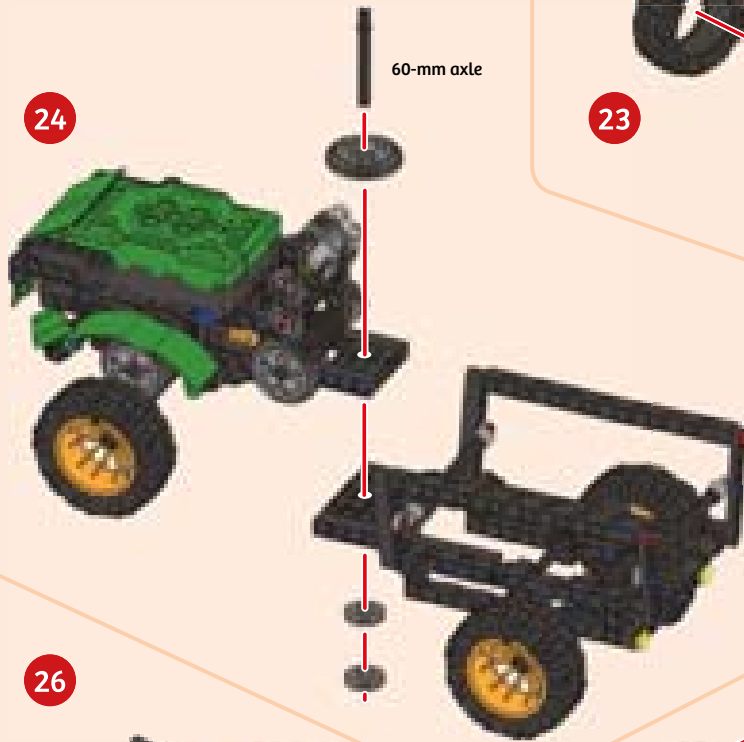

23

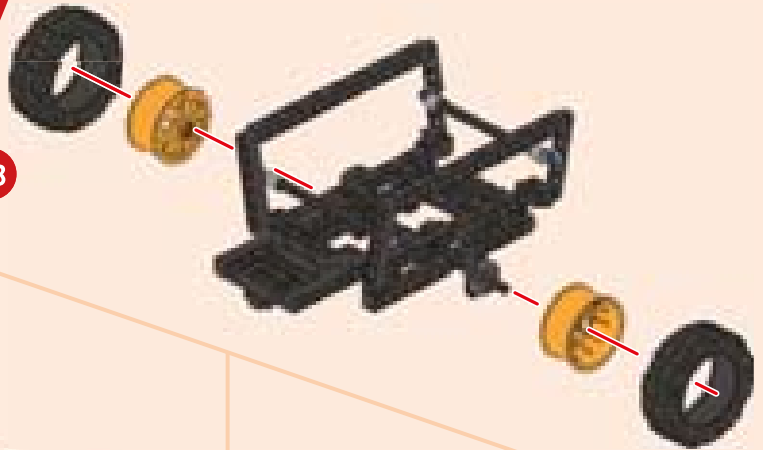

26

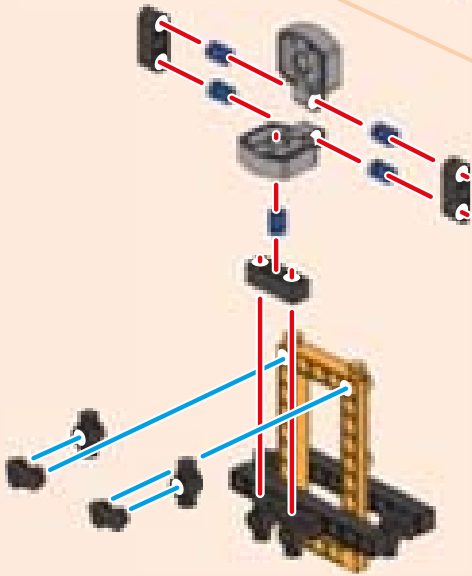

25

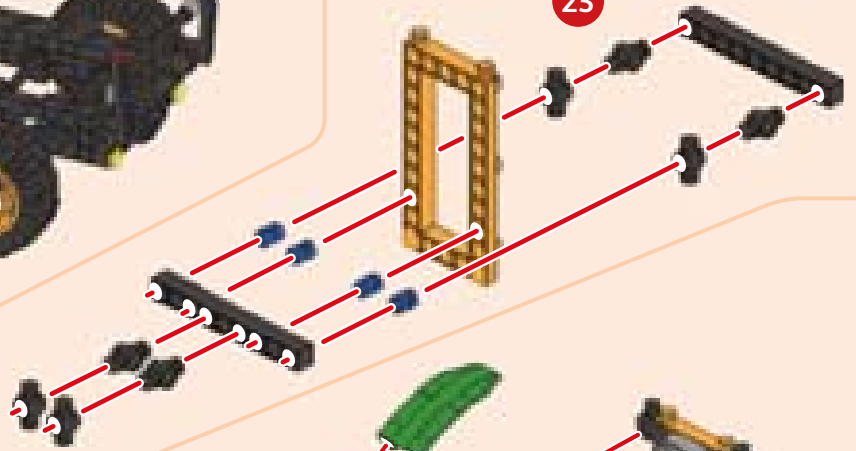

27

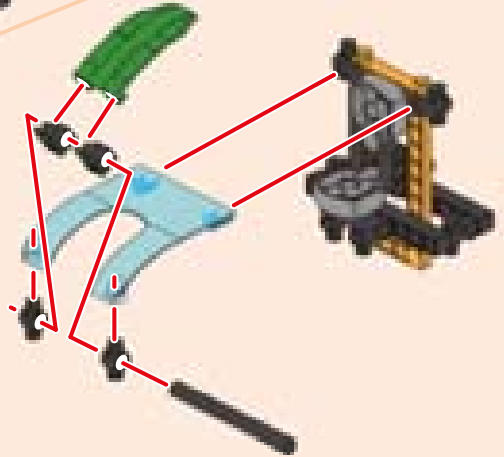

28

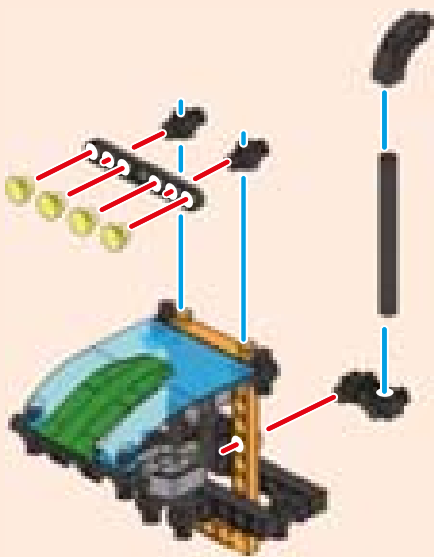

29

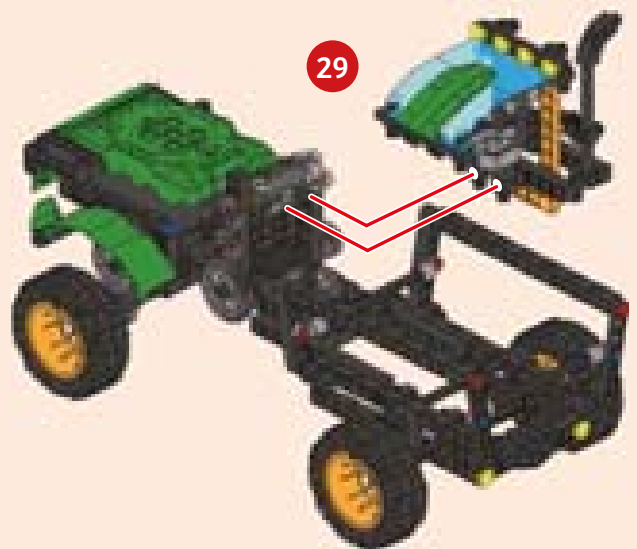

30

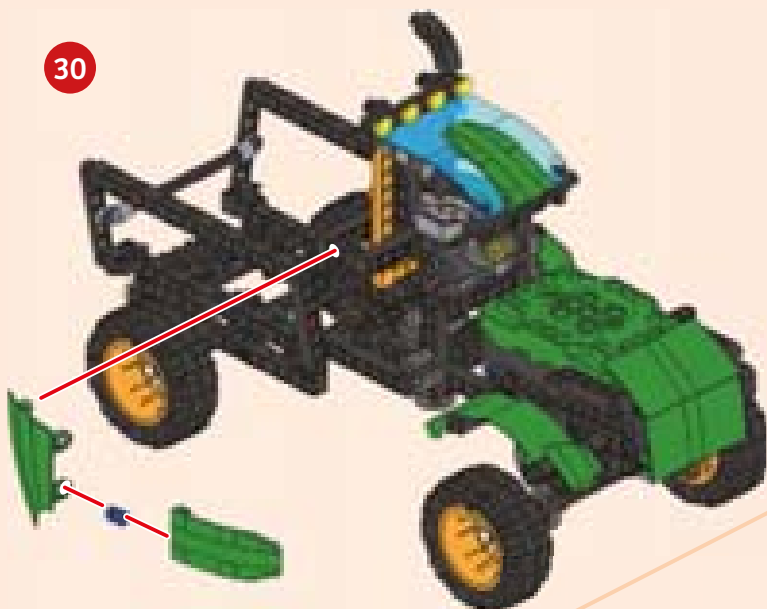

31

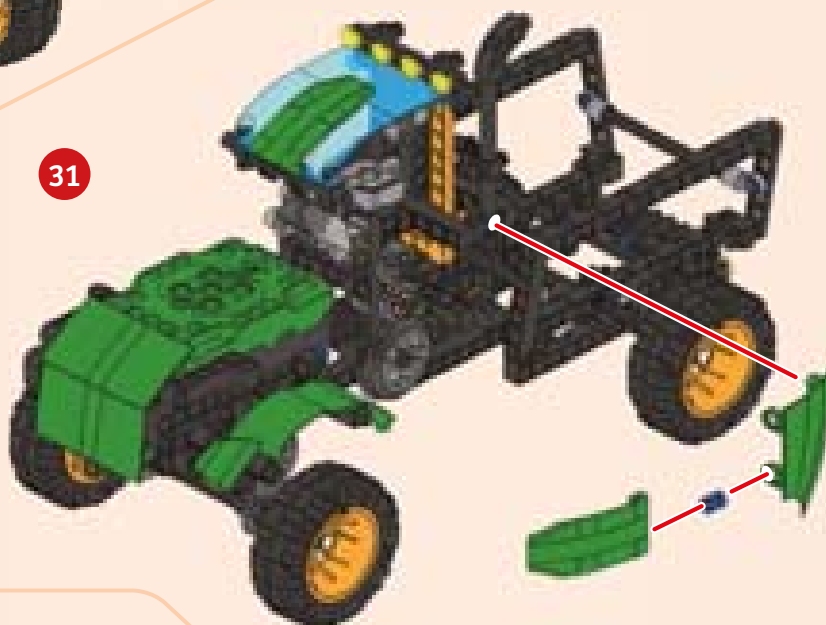

32

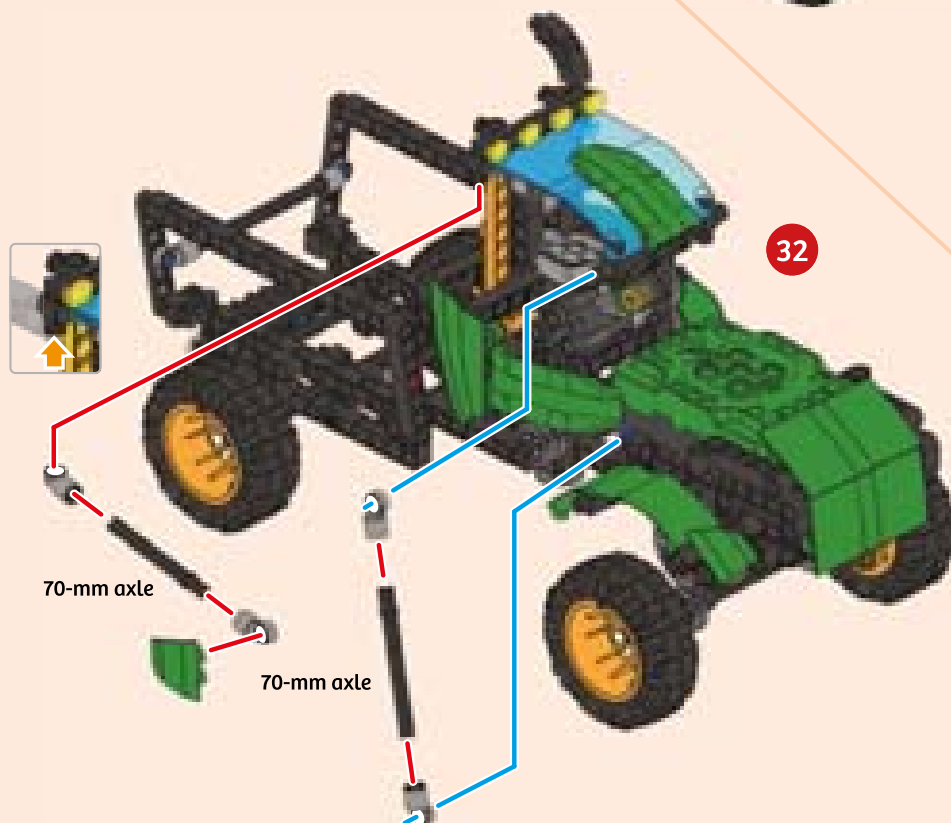



33

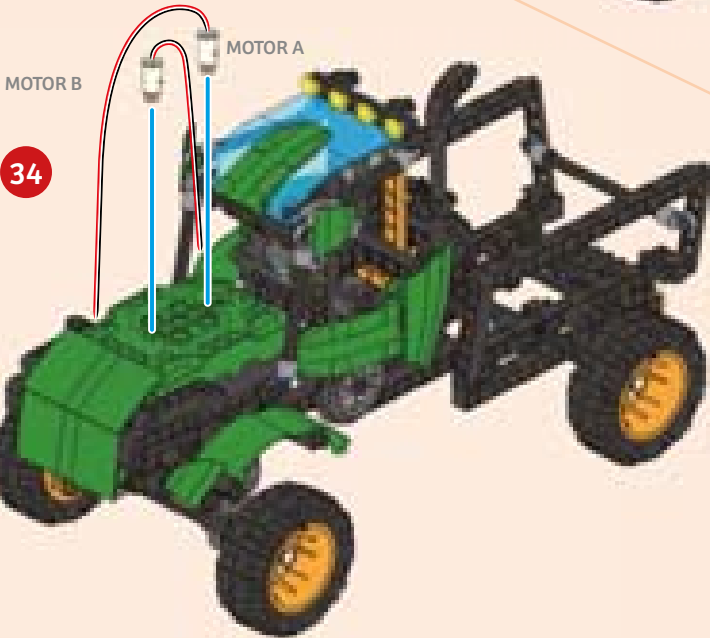
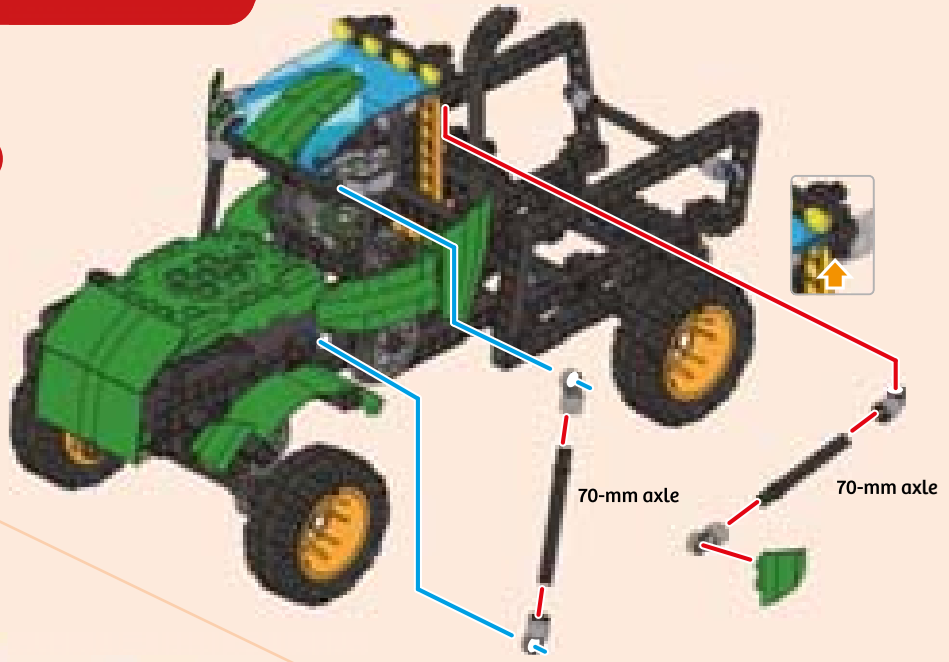

34

EXPERIMENT 6

Lifting materials

HERE'S HOW

Se up an incline using materials like books and cardboard. Time how long it takes for the farm truck to go up the incline. Then place a small heavy object in the back of the farm truck and measure the time again. What happens to the amount of time it takes the truck to go up the incline?

35



Done!



USING REMOTE SENSING TECHNOLOGY

Modern farmers have access to much more information about their land and crops due to two important information systems : **Global Positioning Systems (GPS)** and **Geographic Information Systems (GIS)**. Using these systems farmers are able to understand how different farming techniques influence their crops. This allows farmers to make better decisions about their land and water usage.

GLOBAL POSITIONING SYSTEM (GPS)

The Global Positioning System or GPS is a navigation system, which is often used for finding the directions to a location. Many farmers now use GPS to make a map of their field. This can be used to plan field boundaries, roads, and irrigation systems.

GPS is also used in farm equipment, such as tractors and combine harvesters, to keep track of where they have and haven't been. This allows farmers to follow the same path again and again with different machines. For example, after tilling the ground with a disc harrow, the farmer can follow the same path with a seeder. This ensures that the seeds are only placed in the areas that have been tilled.



GEOGRAPHIC INFORMATION SYSTEMS (GIS)

GIS is a tool used to visualize and analyze geographical data. The power of GIS comes from its ability to analyze different types of data together. For example a farmer can combine rainfall, elevation, slope, and soil type data together using GIS to plan drainage and irrigation in a way that will prevent flooding.

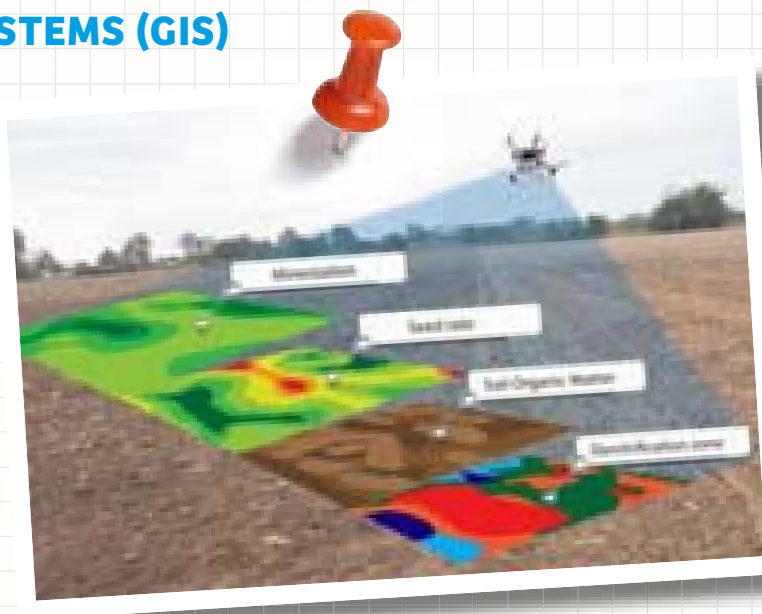



WINDROWER

- 1 1x
- 2 1x
- 3 2x
- 4 3x
- 5 2x
- 6 2x
- 7 2x
- 8 1x
- 9 8x
- 10 7x
- 11 79x
- 12 3x
- 13 7x
- 14 2x
- 15 4x
- 16 4x
- 17 29x
- 18 1x
- 19 1x
- 20 6x
- 21 6x
- 22 2x
- 23 1x
- 24 2x
- 25 3x
- 26 5x
- 27 5x
- 28 4x
- 29 5x
- 30 8x
- 31 2x
- 32 2x
- 33 1x
- 34 9x
- 35 9x
- 36 2x
- 37 1x
- 38 1x
- 39 1x
- 40 3x
- 41 6x
- 42 2x
- 43 8x
- 44 2x
- 45 1x
- 46 1x
- 47 1x
- 48 2x
- 49 2x
- 50 2x
- 51 1x
- 52 4x
- 53 4x
- 54 1x
- 55 2x
- 56 1x
- 57 1x
- 58 2x
- 59 2x
- 60 2x

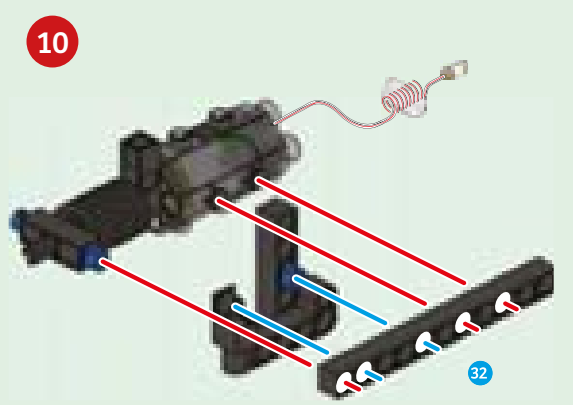
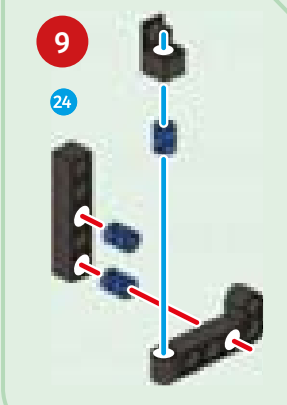
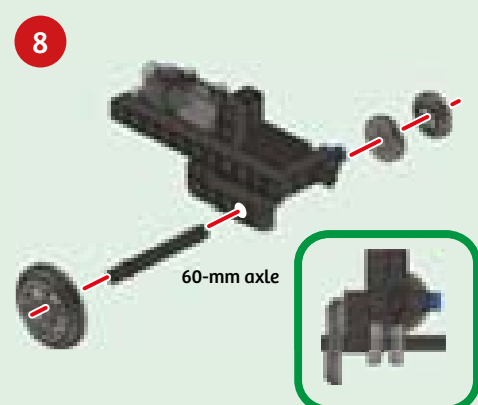
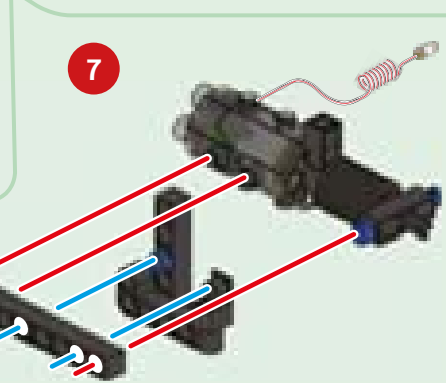
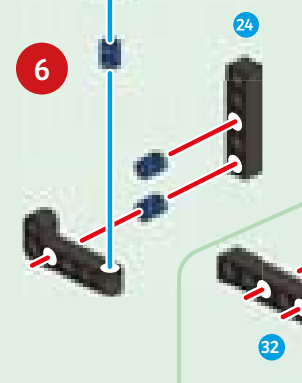
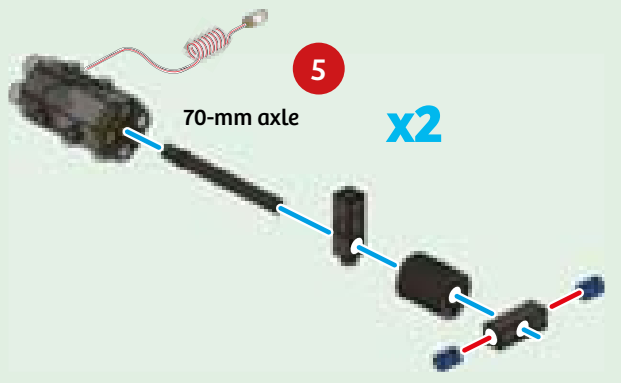
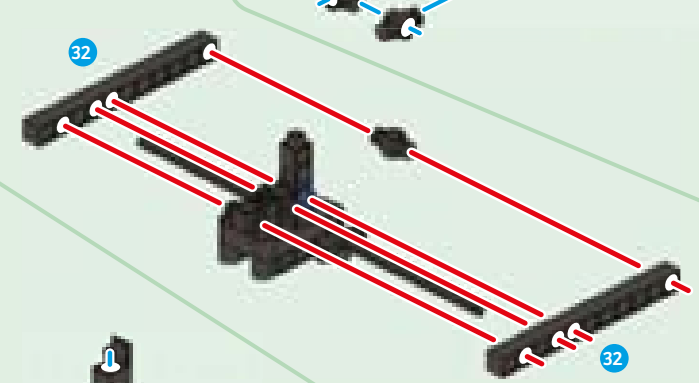
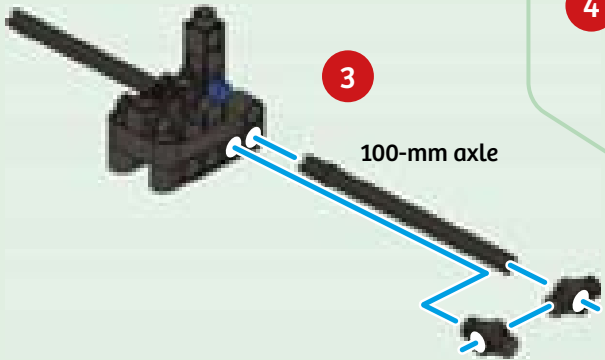
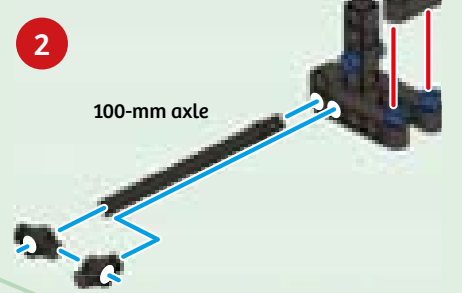
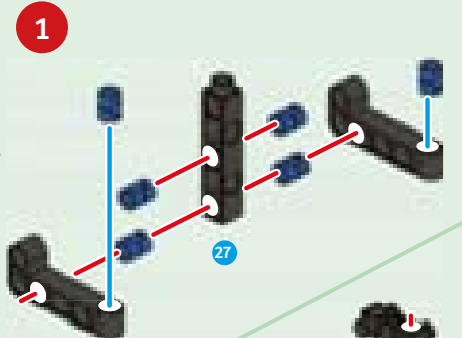

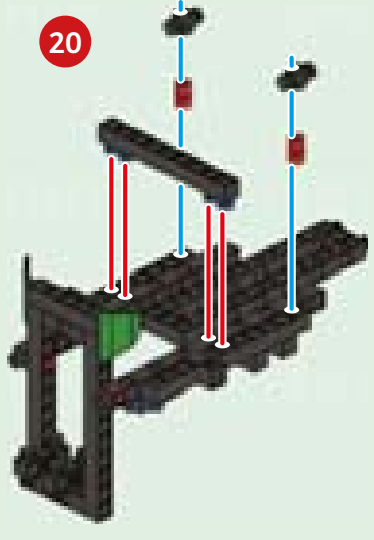
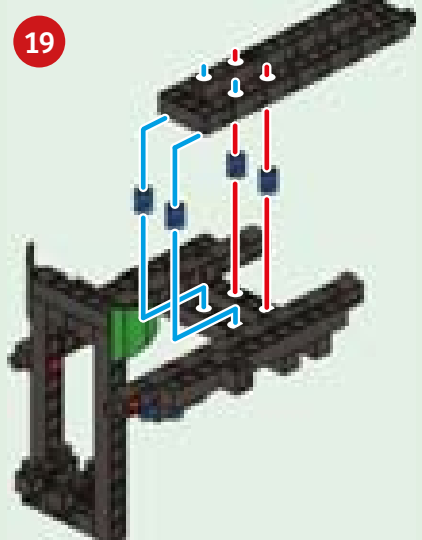
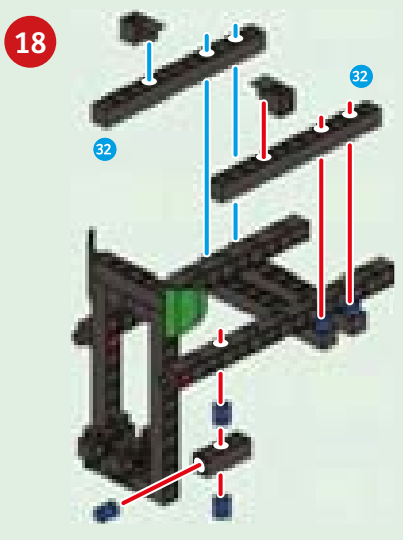
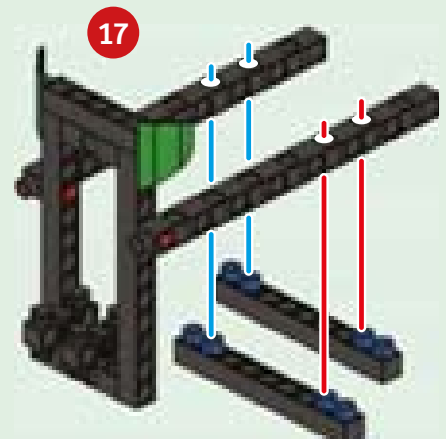
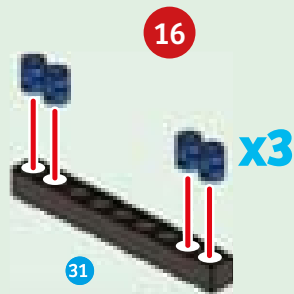
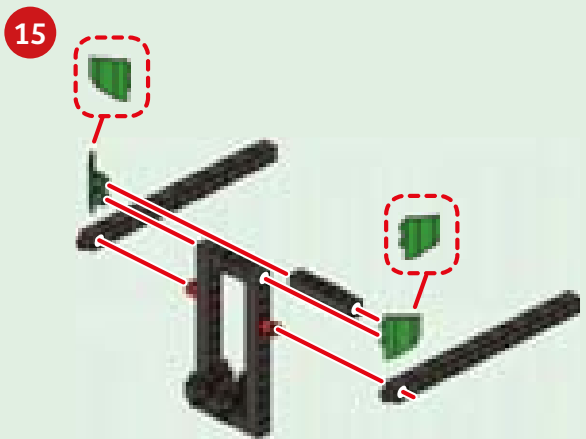
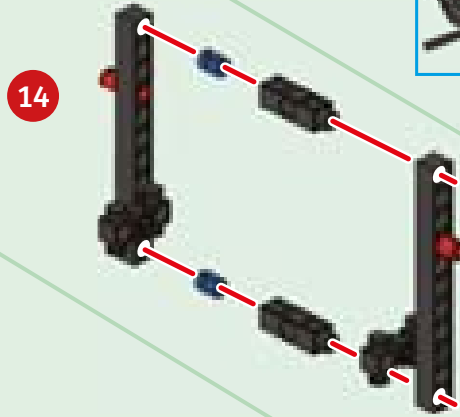
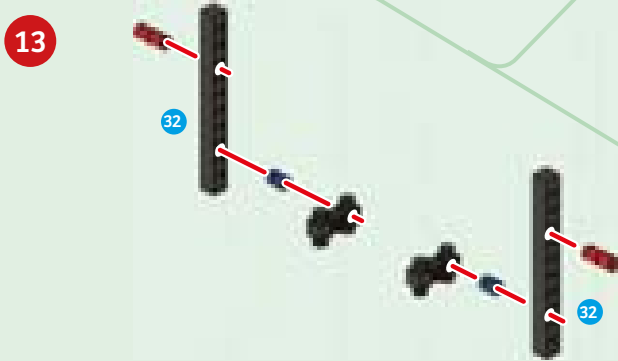
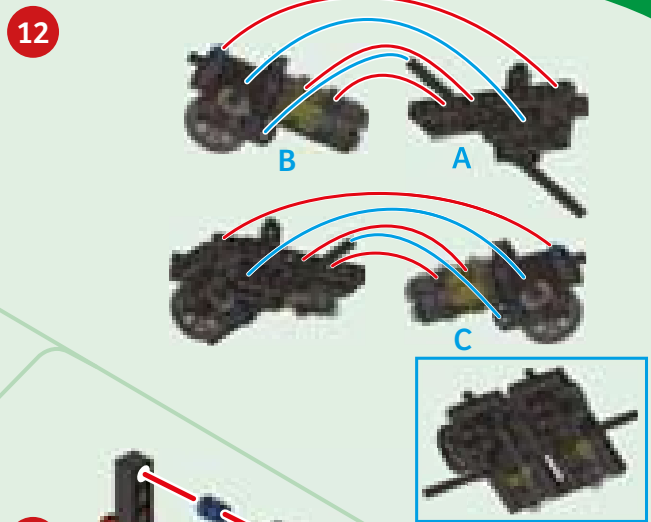
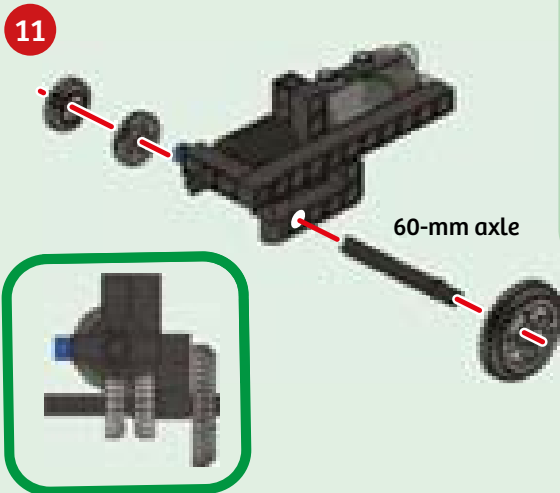



WINDROWER

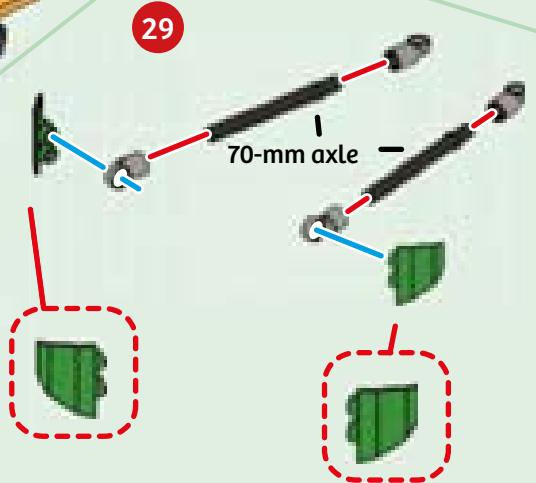
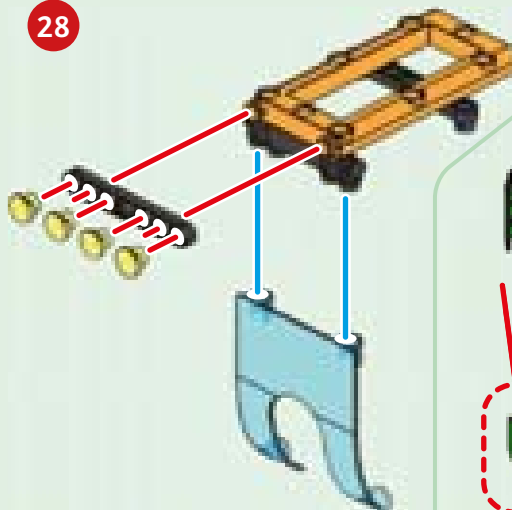
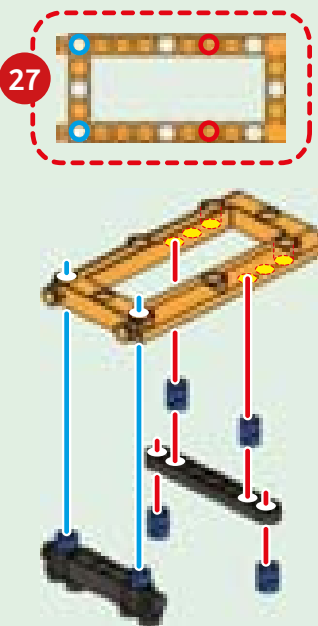
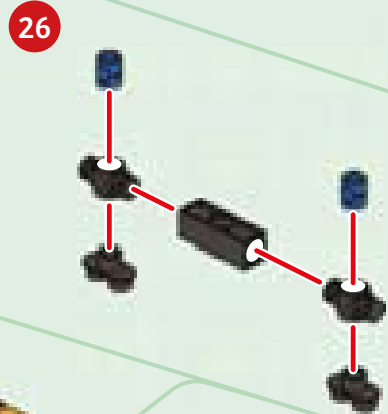
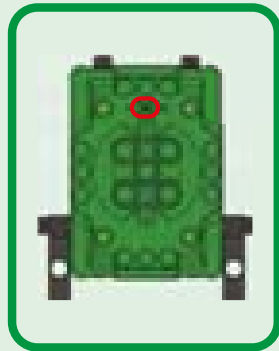
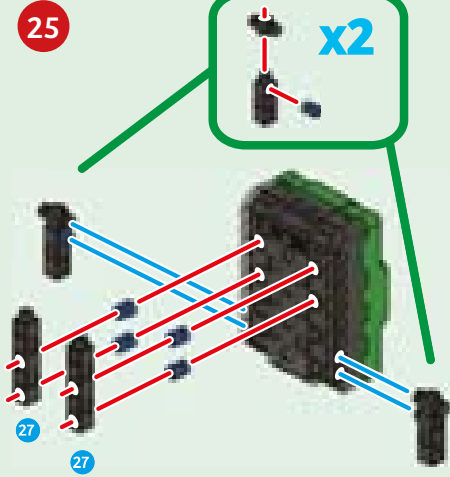
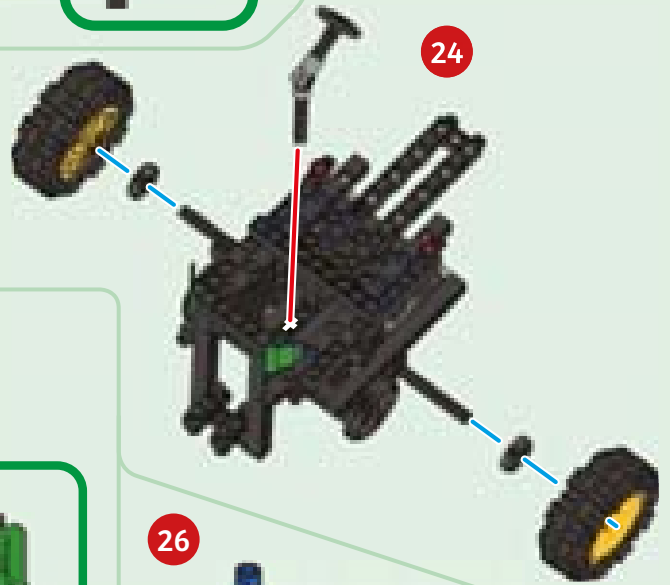
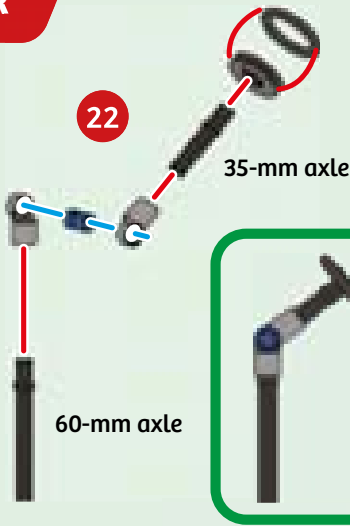
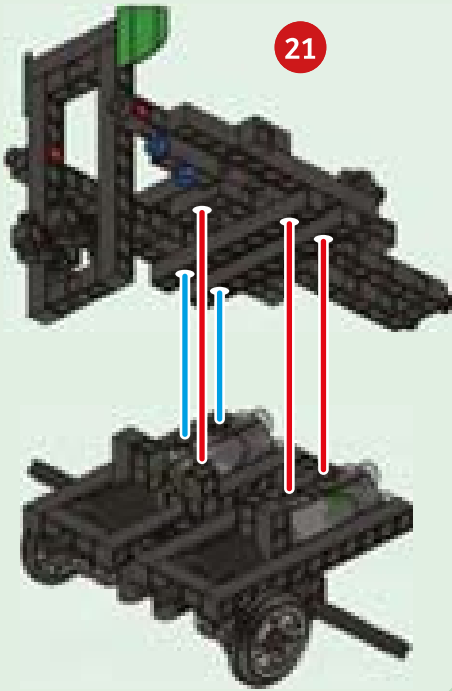

30

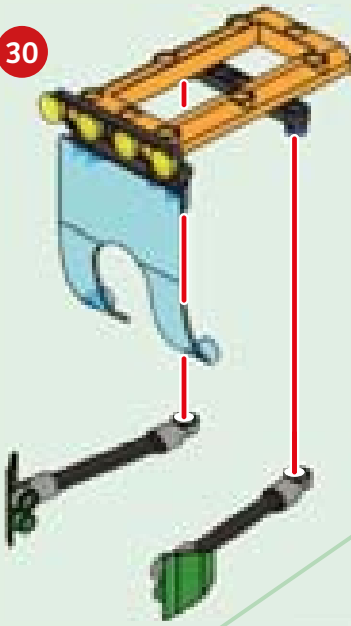

31

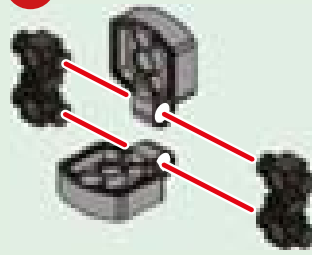

33

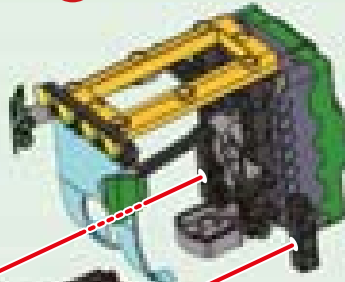

32

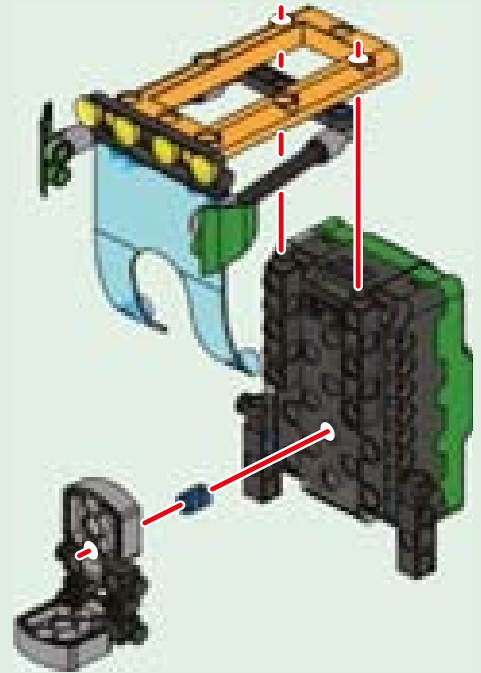

34

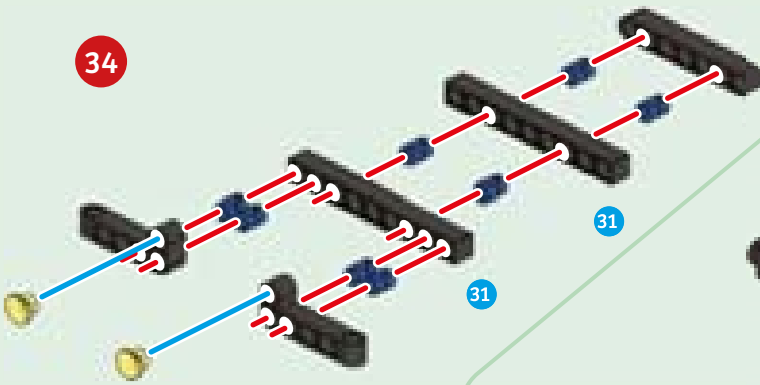

35

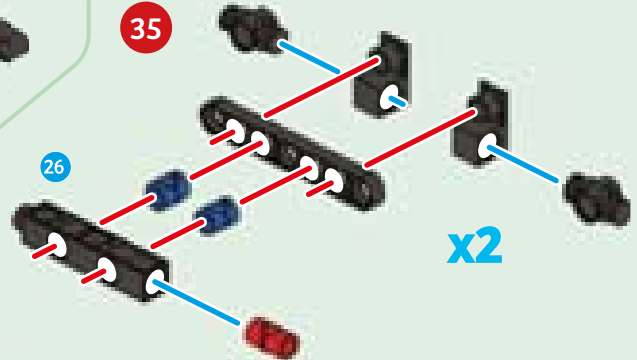

36

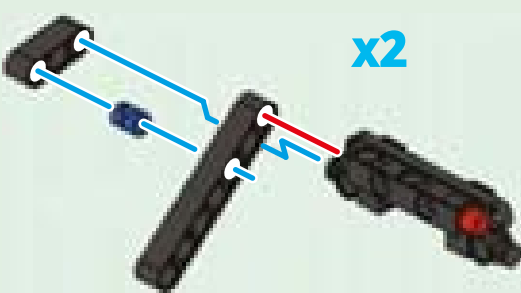

37

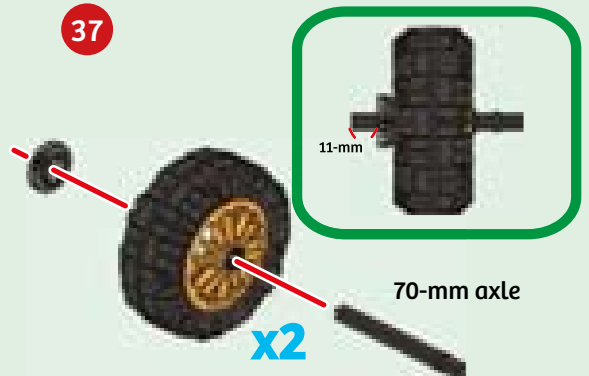



WINDROWER

38

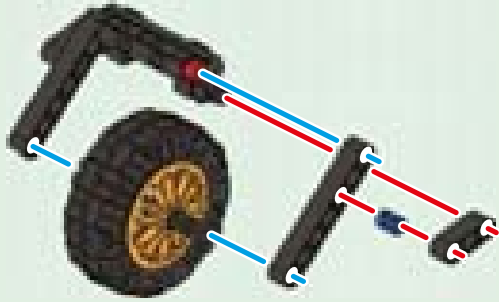

39

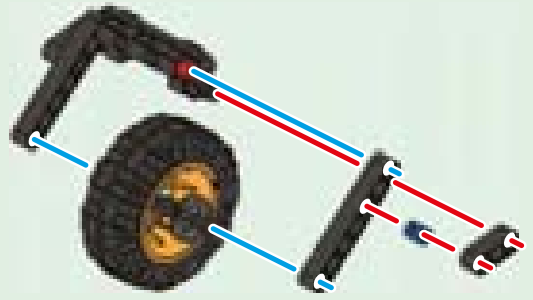

40



41

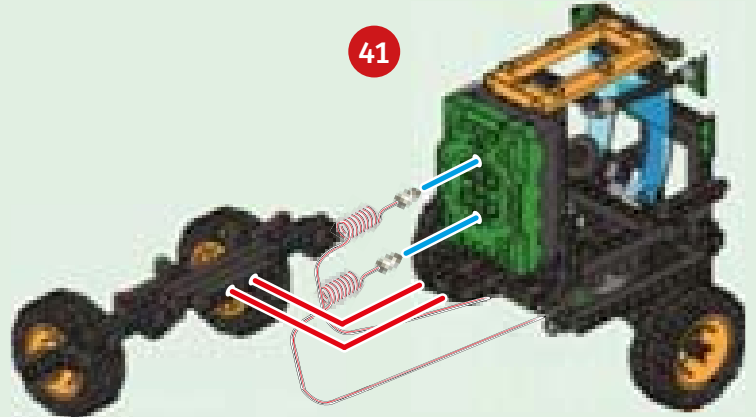

42

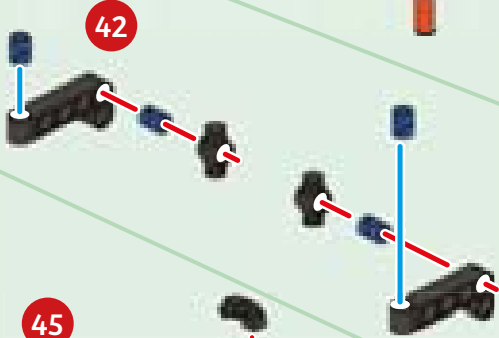

43

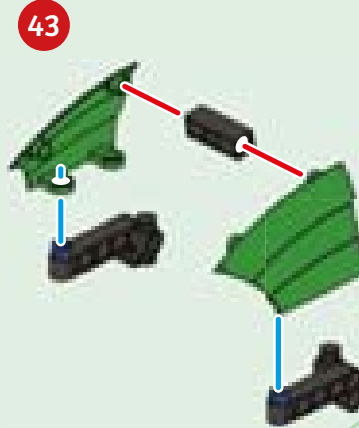

44

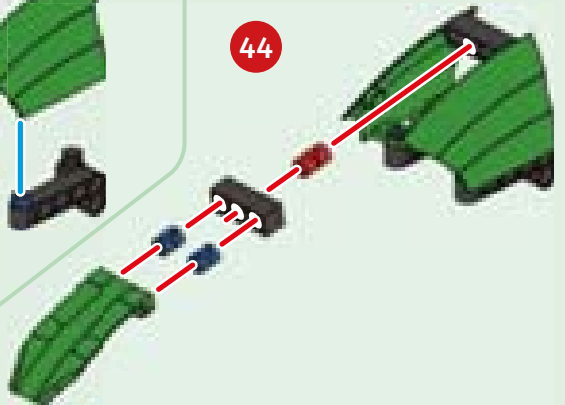

45

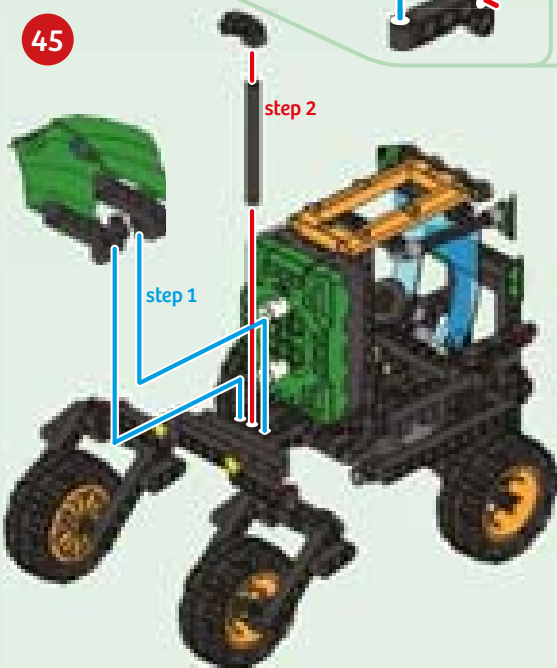

46

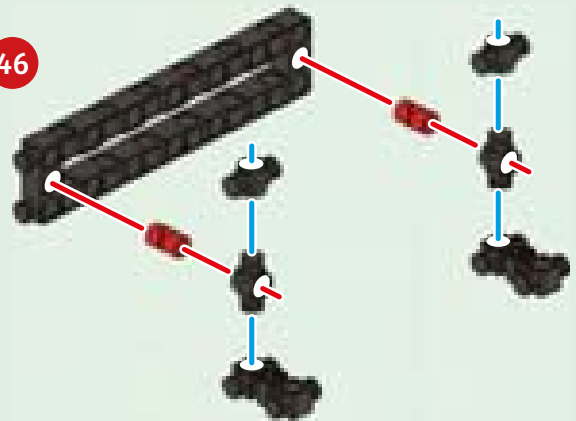

47

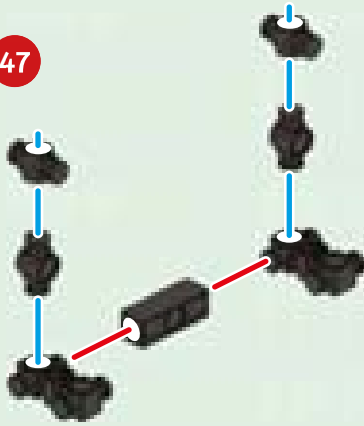

48

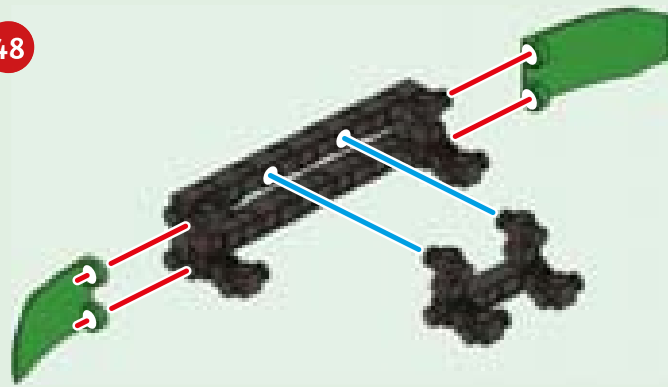

49

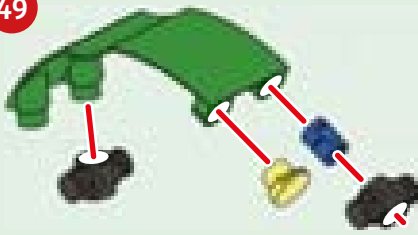

50

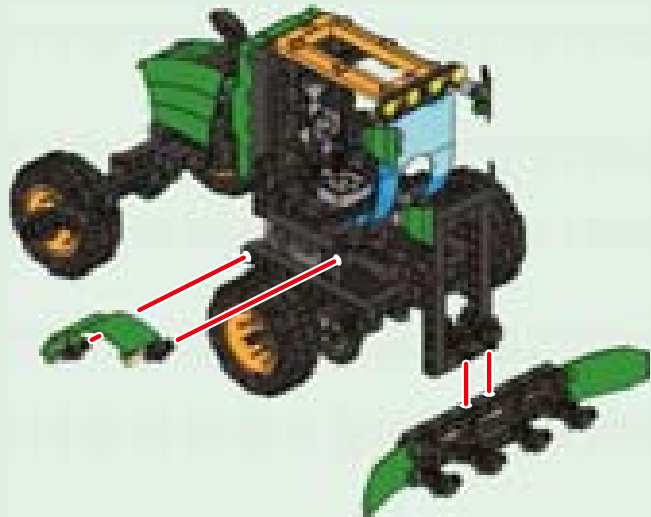

51



52

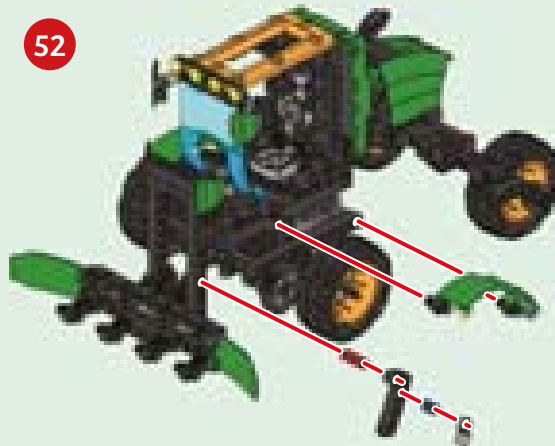

Use the handle to make the front of the windrower go up and down.

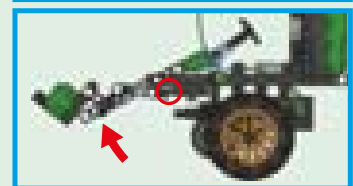
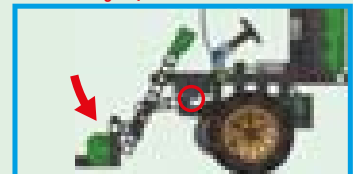

EXPERIMENT 7

Moving materials

HERE'S HOW

Place small light objects around a room. Use the front of the windrower model to move all the objects into one area.

53

Done!



CHECK IT OUT



THE FUTURE OF FARMING

As you have learned, agricultural machinery has made farming much easier and less labor intensive. These machines about have developed and changed over the last 150 years. This trend continues today with the development of new ways to automate farming using technologies such as driverless tractors and drones.



DRIVERLESS TRACTORS



Driverless tractors are programmed to perform their task without the presence of a human. Driverless tractors have developed within the last 10 years because of their reliance on GPS and advances in computers and computer programming.

Developing driverless tractors is challenging because they need to imitate human abilities such as visual observation and decision making. For example, driverless tractors must be able to determine their path, react to unknown situations, and make decisions all in an appropriate amount of time. This is accomplished through the use of sensors that relay information to the

tractor, which is then processed by complex computer programs. For example, the position information from GPS is used by driverless tractors to determine the route and speed that the tractor should follow.

DRONES

A new area of development in agricultural technology is the use of drones. In combination with sensors and imaging technology drones can be used to gather information about fields. For example, drones can capture **infrared** and **visual spectrum** images of crop plants. Infrared light lies beyond the visual spectrum, or the light that human eyes can see. Using these images farmers are able to tell if plants are healthy or unhealthy.

