

## C). SPEED TRANSMITTER AND MAGNET INSTALLATIONS

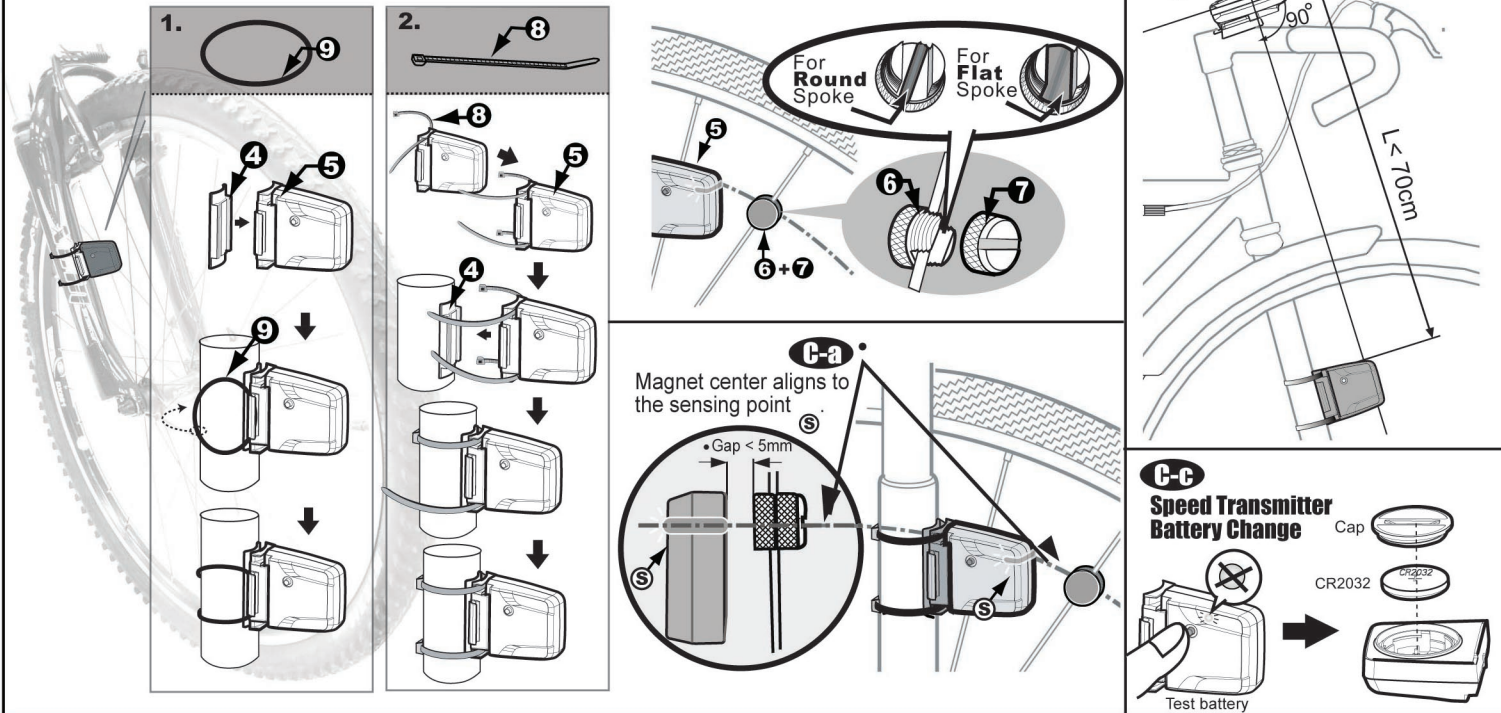

### EN SPEED TRANSMITTER AND MAGNET INSTALLATIONS

- Options to Install the Speed Transmitter (1 And 2.)
- Installation the speed Transmitter unit on the right front fork with rubber pad.
- Installation the magnet on one spoke of the front wheel and let the magnet face the sensing point.
- Adjust the relative position between the main unit and the speed Transmitter, according to the following key points:

- It will receive a stronger wireless signal if the speed Transmitter is more close to the main unit.

The arrow of the speed Transmitter must point to the main unit, and install the speed Transmitter as close to the main unit as possible and within 70 cm to get a better wireless performance.

It is workable when the arrow symbol is down, but keeping the arrow up is better because its sensing distance is shorter than with the arrow down.

- Adjust the installation angle of the speed Transmitter to aim at the direction of the main unit within  $\pm 15^\circ$ , the best performances is at vertical direction ( $90^\circ$ ) between the speed Transmitter arrow and the battery cap of the main unit.
- Adjust the magnet fixed position to let the center of the magnet align to the sensing point.
- Adjust the sensor to let the gap between the magnet and the sensing point is about 5mm.

- Fix all parts and get ready for riding.

### TEST

- The main unit has a "Slide On/Off Detecting Switch" (patents

pending) to turn ON/OFF the power of the wireless receiver. It can receive the wireless wheel signal only after the main unit is slid onto the bracket.

- Spin the front wheel to check if installation is correct. Installation is correct if the main unit flickers "WIRELESS" symbol. It is an incorrect installation if there is no symbol of "wireless" symbol". Please check the relative position among the main unit, the speed Transmitter and the magnet, or refer to the trouble-shooting table. \* "WIRELESS" symbol could be varied by different model.

### THE WIRELESS SYSTEM AND PERFORMANCES

- The speed Transmitter transmits the wheel rotating signal to the receiver in the main unit by the wireless transmission. To prevent the receiver from interfering by other wireless noises and causing the main unit to display false data, install the speed Transmitter according to the following key points to get better performance.

- The receiver is designed to receive a signal with only a certain direction and angle to reduce the noise interference from other sources. Adjust the installation angle of speed Transmitter to aim at the direction to the main unit within a  $\pm 15^\circ$  angle, the best performance is at a vertical direction.

- The receiver will receive a stronger wireless signal if the speed Transmitter is more close to the receiver. A stronger sensing signal not only has better noise immunity, but also increases the speed Transmitter battery's operating life. For good wireless performance, please install the speed Transmitter as close to the main unit as possible and within 70 cm.

- Precaution

This computer has almost no cross-talking interference when 2 bicycles carrying the same or similar wireless cycle computers are ridden side by side, as long as the cross-distance is over 40cm.

- This computer has a "Slide On/Off Detecting Switch" to check the main unit to slide on/off from the bracket.

- To reduce the power consumption of the main unit to increase the battery operation life, but also to delete all indoor electromagnetic interference from electrical equipment (such as PC monitors, handy -phones, etc.). It will turn off the power supply of the receiver when the main unit takes off from the bracket.
- The main unit can only receive the wheel signal after it is slid onto the bracket.

### SPEED TRANSMITTER BATTERY CHANGE (C-C)

- The patent-pending speed Transmitter circuit is designed to reduce power consumption; a 3V battery (typically an CR2032) can operate for over 24,000km (15,000miles) riding distance or 1 years.
- Replace a new battery when the speed Transmitter battery power is nearly exhausted, otherwise the transmission power of the wheel signal will be weak, causing the main unit to display unstable data.
- Replace with a new CR2032 battery with the positive (+) pole toward the speed Transmitter cap.



## **Federal Communication Commission Interference Statement**

This equipment has been tested and found to comply with the limits for a Class B digital device, pursuant to Part 15 of the FCC Rules. These limits are designed to provide reasonable protection against harmful interference in a residential installation.

This equipment generates, uses and can radiate radio frequency energy and, if not installed and used in accordance with the instructions, may cause harmful interference to radio communications. However, there is no guarantee that interference will not occur in a particular installation. If this equipment does cause harmful interference to radio or television reception, which can be determined by turning the equipment off and on, the user is encouraged to try to correct the interference by one of the following measures:

- . Reorient or relocate the receiving antenna.
- . Increase the separation between the equipment and receiver.
- . Connect the equipment into an outlet on a circuit different from that to which the receiver is connected.
- . Consult the dealer or an experienced radio/TV technician for help.

***FCC Caution:*** To assure continued compliance, any changes or modifications not expressly approved by the party responsible for compliance could void the user's authority to operate this equipment. (Example - use only shielded interface cables when connecting to computer or peripheral devices).

This device complies with Part 15 of the FCC Rules. Operation is subject to the following two conditions:

- (1) This device may not cause harmful interference, and
- (2) This device must accept any interference received, including interference that may cause undesired operation.