

Desktop UHF RFID Reader

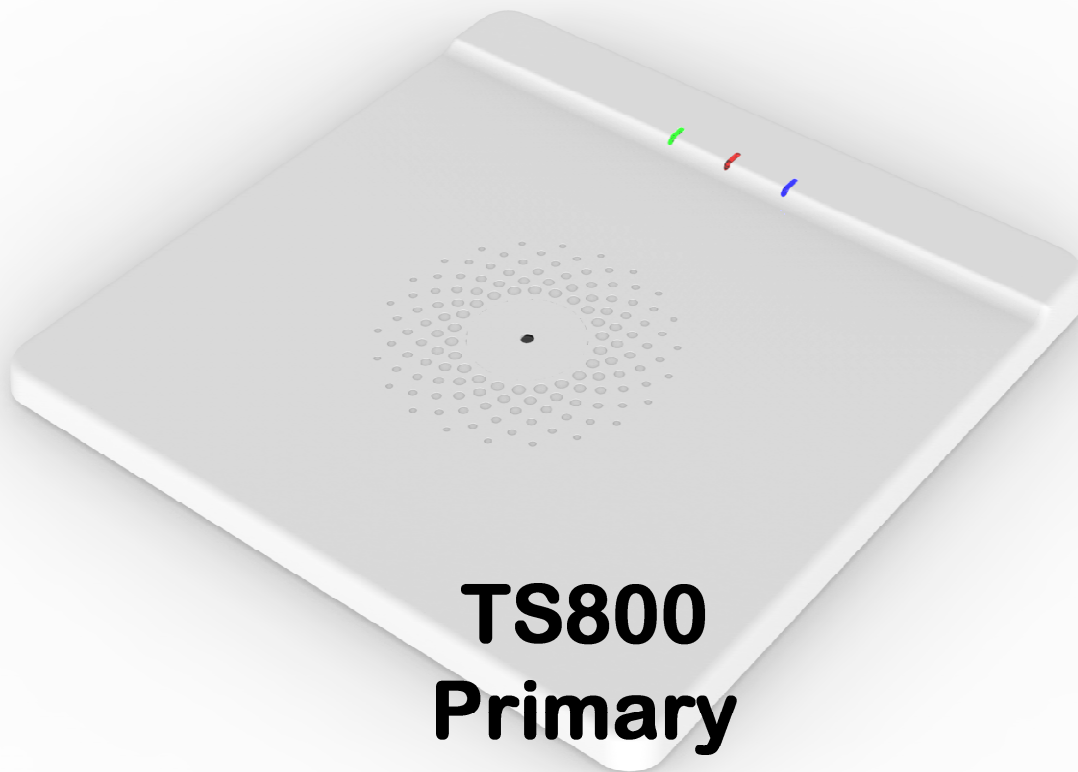

USB Type-C



WiFi

 **Bluetooth**
SMART

2018/03/27

TM970227

Safety Certifications



Has been tested in accordance to essential protection requirements of the R&TTE Directive 1999/5/EC on the approximation of the laws of the Member States relating to Radio Spectrum Matters and found the test results indeed meet the limitation of the relevant test standard(s) listed below:

EMC / Radio Spectrum / Safety / Health

EN55032 Class B (2015)
EN55024 (2010)
ICE/EN61000-4-2 (2009)/-3(2006+A2:210)/-8(2010)
EN 301 489 -1: V2.2.0 (2017)
EN 301 489 -3: V2.1.1 (2017)
EN 301 489 -17: V3.2.0 (2017)
EN 302 208: V3.1.1 : (2016)
EN 302 328: V2.1.1 : (2016)
EN 62368 - 1: 2014/A11 : 2017
EN62311 : 2008



Test standard: FCC rules Part 15 subpart C 15.247 (2017 - 10)

Test Result: No deviations from the technical specification(s) were ascertained in the course of the tests performed.

Test standard: FCC rules Part 15 subpart B

Test Result: Radiated Emission. FCC Part 15. 109 Class B. Test passed.

Federal Communication Commission Interference Statement

This equipment has been tested and found to comply with the limits for a Class B digital device, Pursuant to Part 15 of the FCC Rules. These limits are designed to provide reasonable protection against harmful interference in a residential installation.

This equipment generates, uses and can radiate radio frequency energy and, if not installed and used in accordance with the instructions, may cause harmful interference to radio communications.

However, there is no guarantee that interference will not occur in a particular installation. If this equipment does cause harmful interference to radio or television reception, which can be determined by turning the equipment off and on, the user is encouraged to try to correct the interference by one of the following measures:

- . Reorient or relocate the receiving antenna.
- . Increase the separation between the equipment and receiver.
- . Connect the equipment into an outlet on a circuit different from that to which the receiver is connected.
- . Consult the dealer or an experienced radio/TV technician for help.

FCC Caution: To assure continued compliance, any changes or modifications not expressly approved by the party responsible for compliance could void the user's authority to operate this equipment. (Example - use only shielded interface cables when connecting to computer or peripheral devices).

FCC Radiation Exposure Statement

This equipment complies with FCC RF radiation exposure limits set forth for an uncontrolled environment. This equipment should be installed and operated with a minimum distance of 20 centimeters between the radiator and your body.

This transmitter must not be co-located or operating in conjunction with any other antenna or Transmitter. The antennas used for this transmitter must be installed to provide a separation distance of at least 20 cm from all persons and must not be co-located or operating in conjunction with any other antenna or transmitter.

This device complies with part 15 of the FCC rules. Operation is subject to the following two conditions

- (1) This device may not cause harmful interference and
- (2) This device must accept any interference received, including interference that may cause undesired operation.

Contains transmitter module: FCC ID: 2AC7Z-ESPWROOM02, FCC ID: 2AE2I-ACI810700S

TS800 Reading Station's innovative design combines industry-leading UHF reader technology with a unique embedded antenna into a single, flexible, cost-effective RFID solution for various applications such as point-of-sales, document tracking, RFID programming stations and so on. Small in size and convenient, the TS800 Reading Station is compact enough to fit on most point of sales or desktop stations.

TS800 is a low-profile, fully integrated Reading Station with controlled read/write fields for use-cases that demand accurate, well-defined reading zones such as those found in Retail applications or any other application requiring a powerful UHF reading station for stacked RFID-tagged items.

TS800 Is a fixed device that can be fixed on wall or under/built-I the table for any application that requires a fixed working place.

Features

- 20mm Low-profile, fully integrated Reading Station with antenna
- UHF RF Interface Compliant with EPC Class1 Gen2,ISO18000-6C
- Configurable RF output power up to 24dBm
- Up to 30cm reading range. (depend on transponder)
- Can be mounted on a metal desk
- The limited field can only be read above
- Support USB Visual Com and HID with USB Type C connector
- Integrated wakeup sensing system or external digital input for low power detection of object presence
- Built-in digital input / output for external control
- Power supply from the USB port.
- 2.4 GHz WiFi interface support 802.11 b/g/n
- Optional Bluetooth Low Energy (BLE4.0)
- Optional support iOS / Andriod Application APP

Indicator and Connection

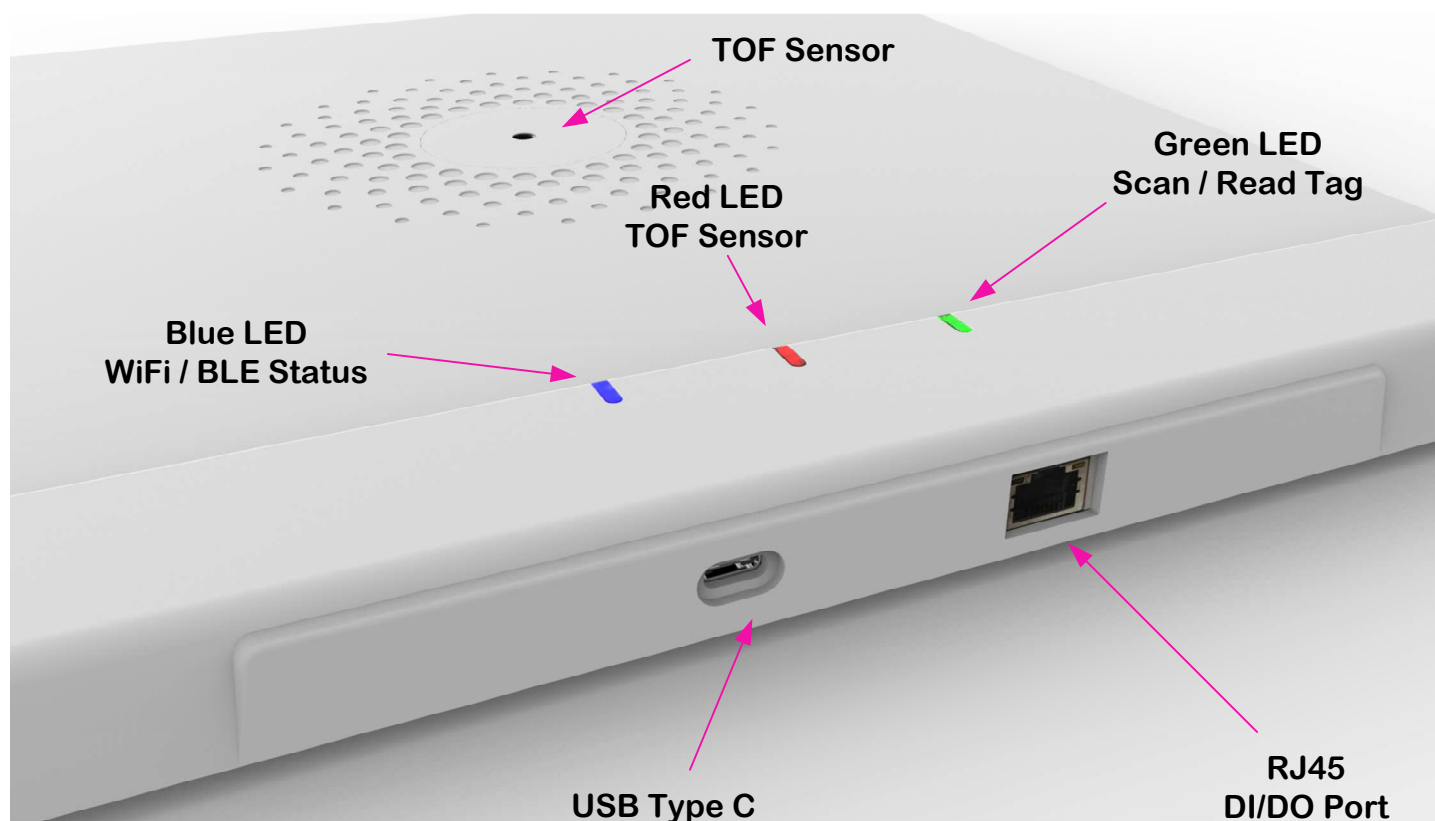

Indicator	Action	Description
Green LED Scan / Read Tag	Off	Standby
	Flicker	Scan Tag
	On	Tag is read
Red LED TOF Sensor	Off	No objects detected in the field
	Flicker	Field detected objects but not into the scanning range.
	On	Field detected objects and into the scanning status.
Blue LED WiFi/BLE Status	Off	Power Off
	Flicker	WiFi / BLE Connecting search
	On	Wifi / BLE is Connected

Connector	Description
USB Type C	USB 2.0 for HID or Visual Com Port for Communication and Power
RJ45	Digital Input *3 , Digital Output*2 , GND and 5VDC output

Sensor	Description
TOF sensor	Detection of object presence and than trigger scan

Technical Specifications

RFID Operating Frequency	UHF RFID : EU: 865~868 MHz US: 902~928 MHz
Supported Transponders	EPCglobal Class1 Gen2 ISO18000-6C
Power Requirement	5VDC from USB Type C / 900mA
Power Consumption	2.8 W max
Output Power	Adjustable 10 ~ 24 dBm
Reading Range	Up to 30 cm
Antenna	-5.5 dBi Integrated antenna
Communication Interface	Wire : USB 2.0 Type C HID or Visual Com Port Wireless LAN : 2.4GHz WiFi , 802.11 b/g/n Support WPA/WPA2 Support Smart Link Function for both Android and iOS device Bluetooth : Bluetooth Low Energy, Bluetooth v4.2 Compliant Protocol Stack For Single-Mode
Indicators	Green LED for RFID Scan, Tag Read Red LED for Object detection Blue LED for Communication status Buzzer for sound
I/O Connection	RJ45 8-pin connector providing GPIO signals
Sensor	Time of Flight Ranging sensor
Temperature	Operating : -10°C to +60°C Storage : -20°C to 70°C
Dimensions(L x W x H)	32.0 cm x 32.0 cm x 2.0 cm
Weight	Approx. 1.5kg without accessory
Housing Material	ABS Plastic / Metal
Color	White

DIMENSION

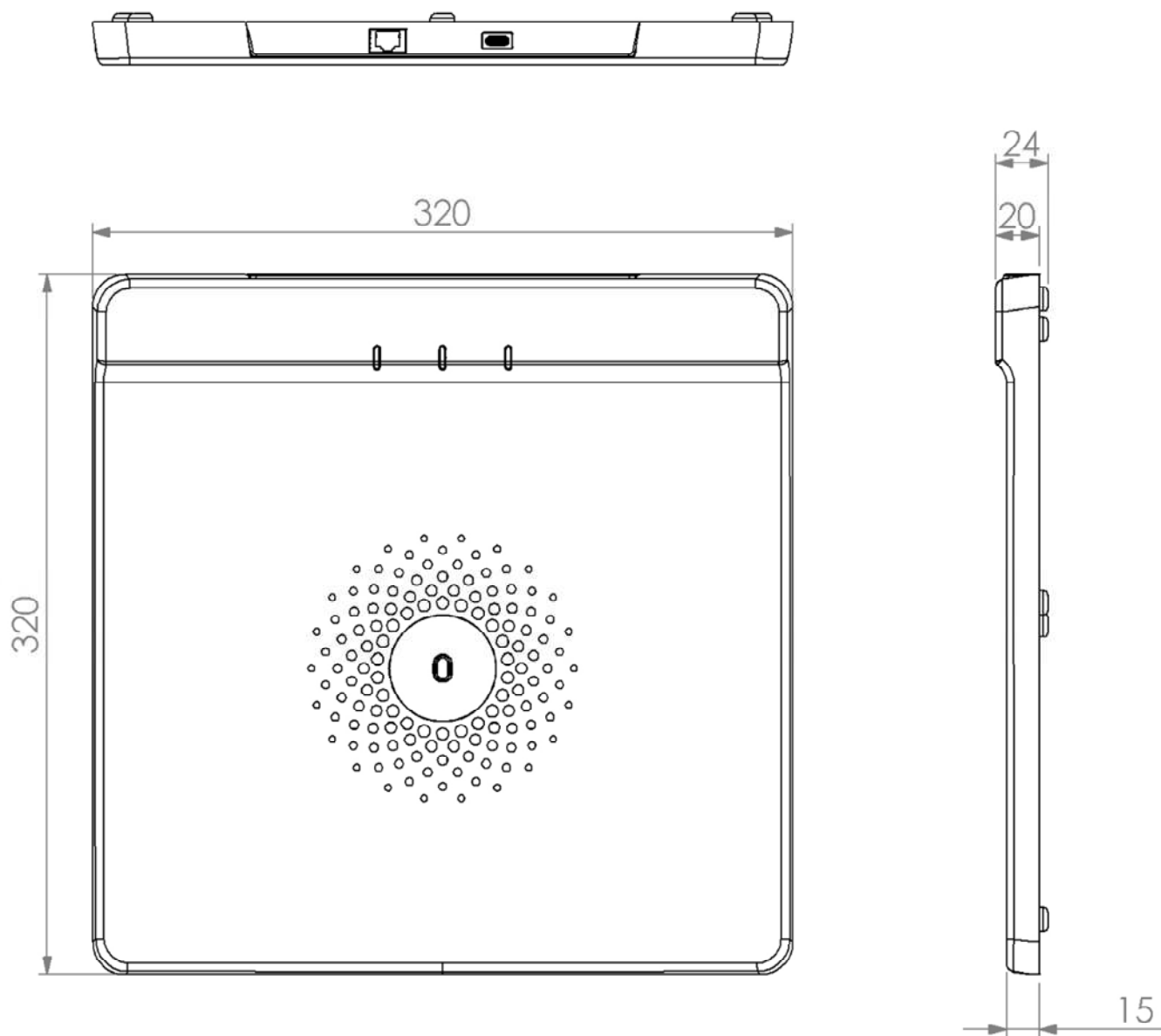

UNIT : mm

Connect with USB



PC USB Port

RJ45 I/O Port

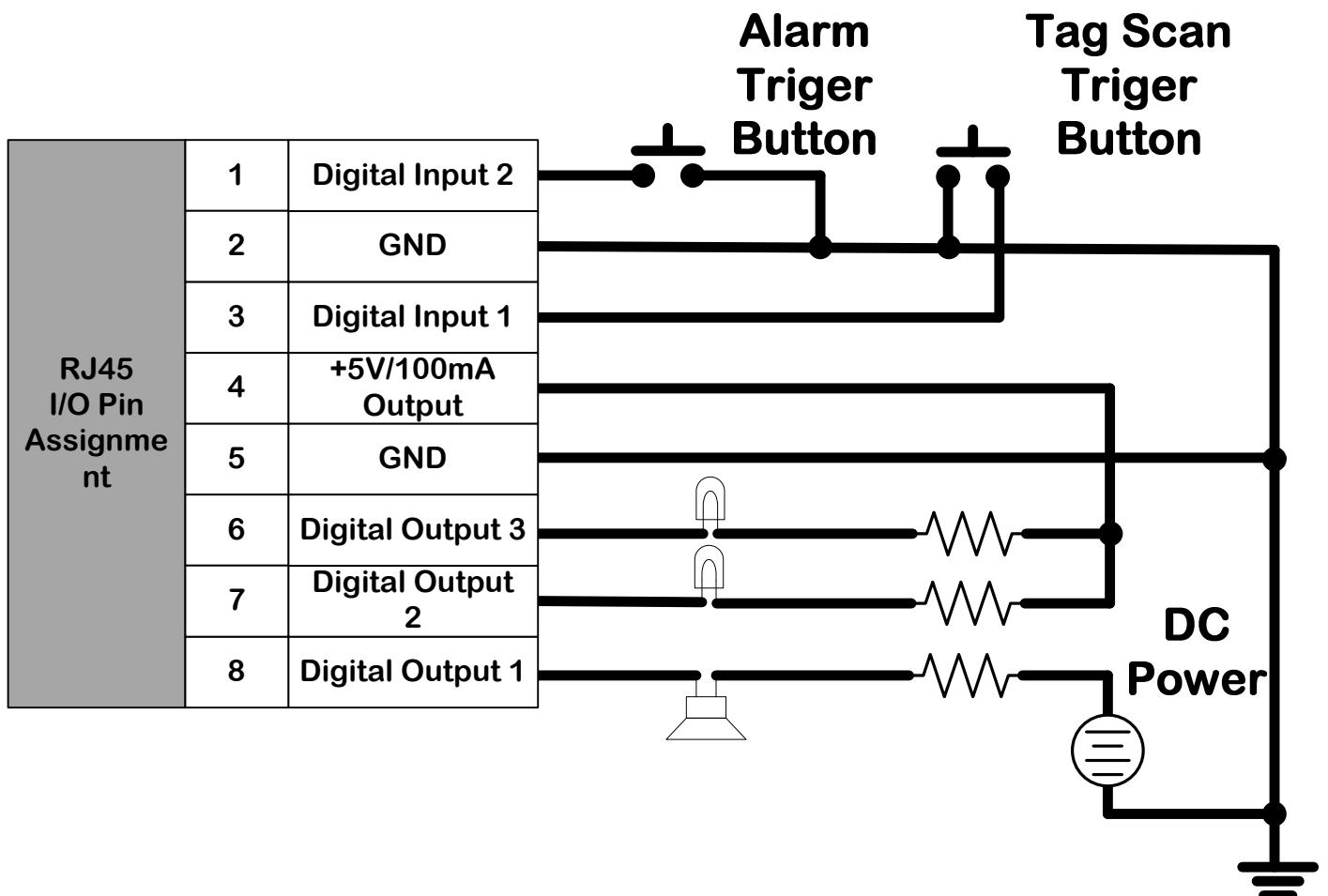

Connect by wireless



BLE



WIFI



**Connect DC +5V
USB Power
Adapter**

**RJ45 I/O
Port**

