

UM800 Series

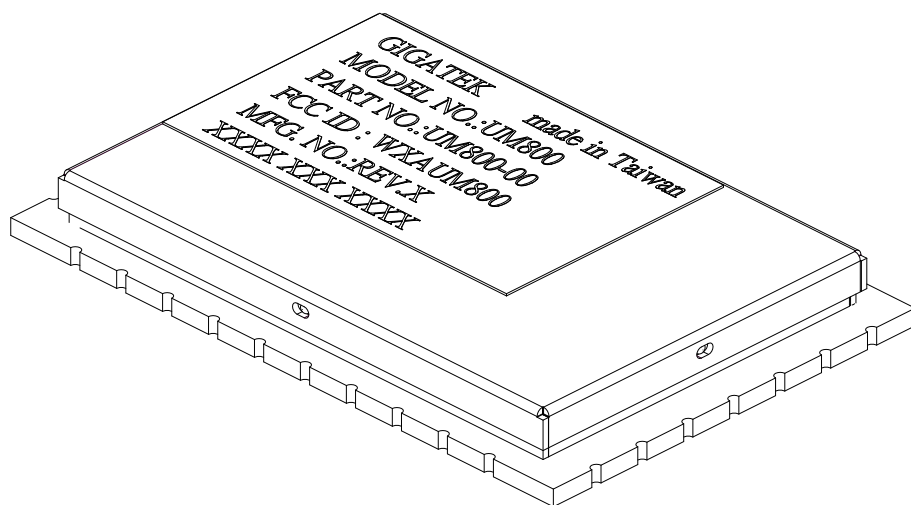

Embedded UHF RFID Read/Write Module User's Manual

TM970177

Federal Communication Commission Interference Statement

This equipment has been tested and found to comply with the limits for a Class B digital device, pursuant to Part 15 of the FCC Rules. These limits are designed to provide reasonable protection against harmful interference in a residential installation.

This equipment generates, uses and can radiate radio frequency energy and, if not installed and used in accordance with the instructions, may cause harmful interference to radio communications. However, there is no guarantee that interference will not occur in a particular installation. If this equipment does cause harmful interference to radio or television reception, which can be determined by turning the equipment off and on, the user is encouraged to try to correct the interference by one of the following measures:

- . Reorient or relocate the receiving antenna.
- . Increase the separation between the equipment and receiver.
- . Connect the equipment into an outlet on a circuit different from that to which the receiver is connected.
- . Consult the dealer or an experienced radio/TV technician for help.

FCC Caution: To assure continued compliance, any changes or modifications not expressly approved by the party responsible for compliance could void the user's authority to operate this equipment. (Example - use only shielded interface cables when connecting to computer or peripheral devices).

End Product Labeling

This transmitter module is authorized only for use in devices where the antenna may be installed such that 20 cm may be maintained between the antenna and users. The final end product must be labeled in visible area with the following: “Contains FCC ID: WXAUM800”

”

End Product Manual Information

The user manual for end users must include the following information in a prominent location “IMPORTANT NOTE: To comply with FCC RF exposure compliance requirements, the antenna used for this transmitter must be installed to provide a separation distance of at least 20cm from all persons and must not be colocated or operating in conjunction with any other antenna or transmitter.” This device complies with part 15 of the FCC rules. Operation is subject to the following two conditions (1) This device may not cause harmful interference and (2) This device must accept any interference received, including interference that may cause undesired operation.

IMPORTANT NOTE: In the event that these conditions can not be met (for example certain laptop configurations or colocation with another transmitter), then the FCC authorization is no longer considered valid and the FCC ID can not be used on the final product. In these circumstances, the OEM integrator will be responsible for reevaluating the end product (including the transmitter) and obtaining a separate FCC authorization. This device is intended only for OEM integrators under the following conditions: The antenna must be installed such that 20 cm is maintained between the antenna and users. As long as a condition above is met, further transmitter test will not be required. However, the OEM integrator is still responsible for testing their end product for any additional compliance requirements required with this module installed (for example, digital device emissions, PC peripheral requirements, etc.).

FEATURES

- Low cost ,Small Outline 30x20x3.6mm
- Compliant with EPCglobal Class1 Gen2 (ISO18000-6C)
- Operating Frequency 840 ~ 960 MHz
- Adjustable Transmit Output Power from +10 to +22dBm
- Operate voltage range 5 V
- Low power consumption: 50mA@ standby, 250mA @22dBm Output
- USB HID or UART TTL Interface
- 12 GPIO for Customize Application
- No RF Connect and Cable request
- Support In-System Programmable and Self Firmware Update
- Provides Development Kit - UM800DK

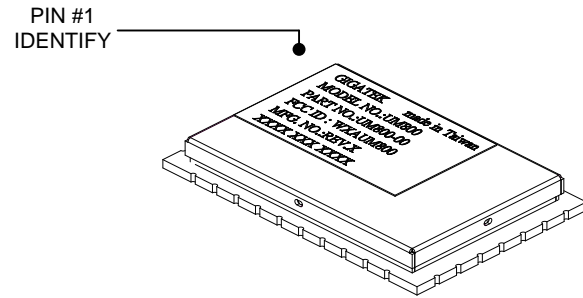

PIN DIAGRAMS

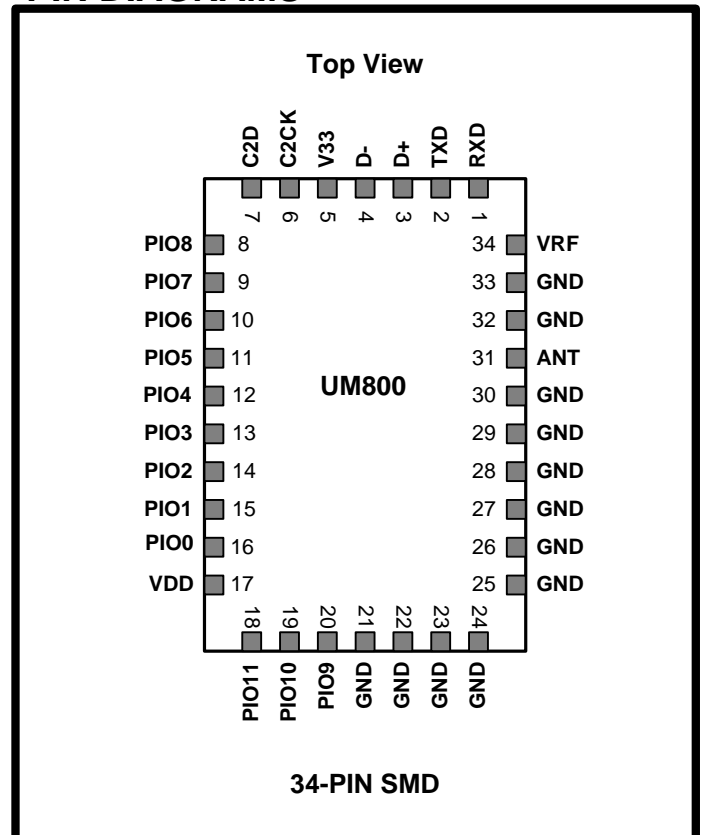

APPLICATIONS

- Access Control System
- Security System
- RFID Printer
- Mobile Phone
- Point of Sale
- Patrol System
- Portable Battery Device

DESCRIPTION

UM800 is a compact and practical embedded UHF reader module which compliant with EPC Global Class1 Gen2.

With small dimensions (30x20x3.6mm) and low power consumption (50mA for standby;250mA, 22dBm for output) make UM800 an ECO friendly choice for your system.

With adjustable frequency (840~960 Mhz), adjustable transmit output (10 to 22dBm), optional interface (USB or UART TTL) and 12 GPIO enable you the flexibility for various applications under different environments.

UHF is one of the best solutions for middle and long range RFID applications.

Such as access control, parking, logistic and vehicle tracking etc.

Using UM800, you can extend the wonderful experience to portable or mobile devices.

GIGA-TMS makes what you need and customizes what you want.

PIN FUNCTIONS

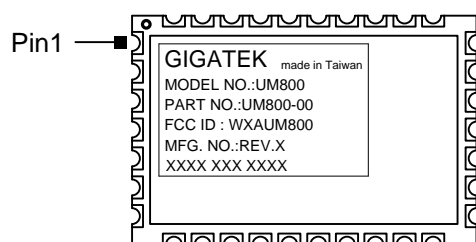

Top View

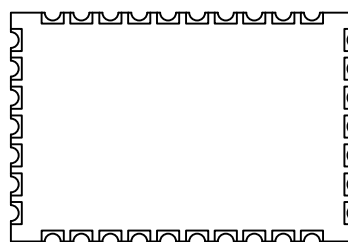

Bottom View

PIN	PIN NAME	I/O	FUNCTION DESCRIPTION
1	RXD	I	USART asynchronous input.
2	TXD	O	USART asynchronous transmit.
3	D+	I/O	USB Differential Plus Line
4	D-	I/O	USB Differential Minus Line
5	V33	P	3.3V Voltage Output, Maximal 100mA Current Output
6	C2CK	I/O	ISP
7	C2D	I/O	ISP
8	PIO8	I/O	GPIO , 5 V tolerant with high sink current
9	PIO7	I/O	GPIO , 5 V tolerant with high sink current
10	PIO6	I/O	GPIO , 5 V tolerant with high sink current / Wiegand Data0
11	PIO5	I/O	GPIO , 5 V tolerant with high sink current / Wiegand Data1
12	PIO4	I/O	GPIO , 5 V tolerant with high sink current
13	PIO3	I/O	GPIO , 5 V tolerant with high sink current
14	PIO2	I/O	GPIO , 5 V tolerant with high sink current
15	PIO1	I/O	GPIO , 5 V tolerant with high sink current
16	PIO0	I/O	GPIO , 5 V tolerant with high sink current
17	VDD	P	5 V Power Supply (5.3V is suggested)
18	PIO11	I/O	GPIO , 5 V tolerant with high sink current
19	PIO10	I/O	GPIO , 5 V tolerant with high sink current
20	PIO9	I/O	GPIO , 5 V tolerant with high sink current
21~30	GND	P	Power Ground
31	ANT	A	Connect To Antenna
32~33	GND	P	Power Ground
34	VRF	P	RF PA power supply Input (UM800 not use)

[Note 1] I : Input , O : Output , I/O : Input or Output , P : Power , A : Antenna

APPLICATION CIRCUIT

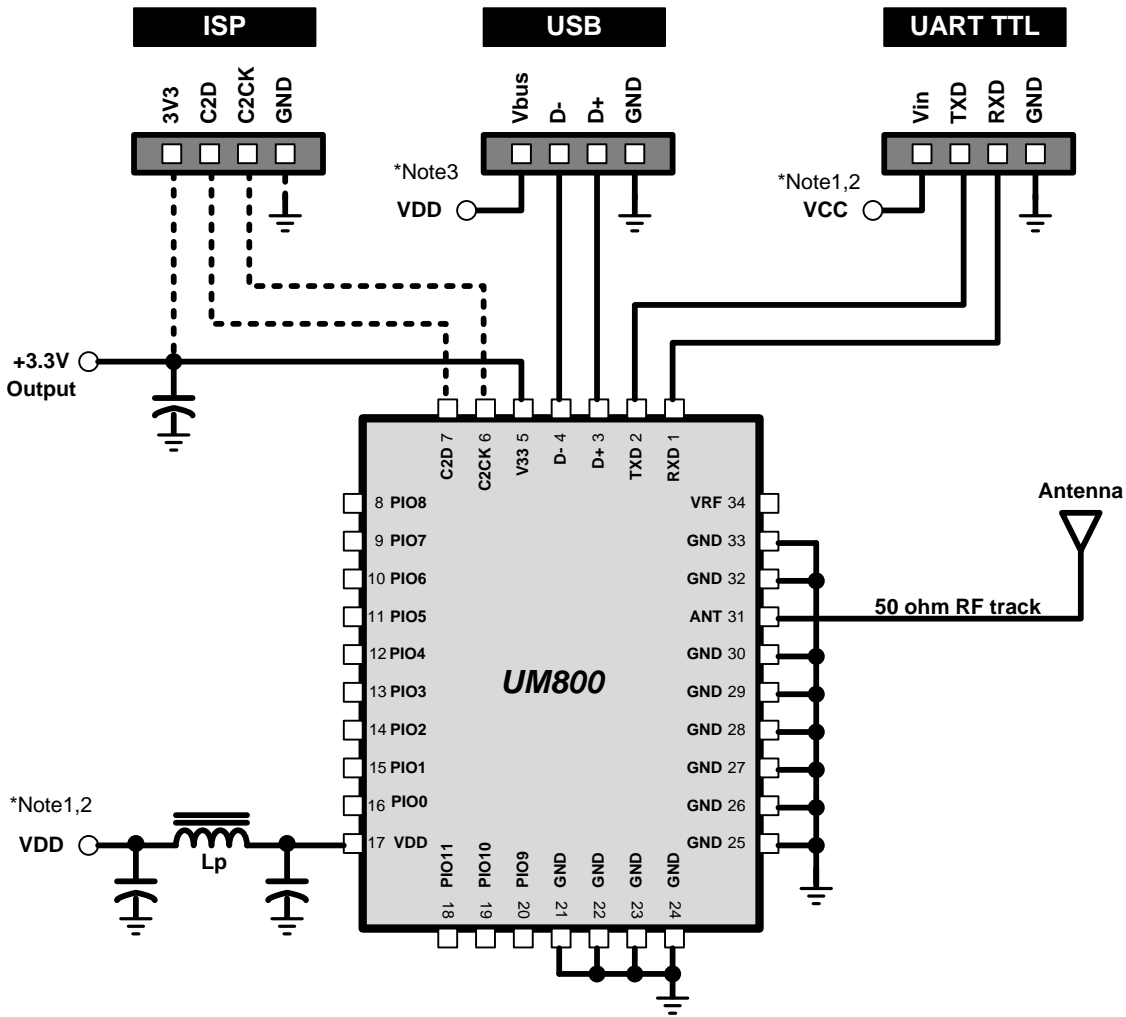

[Note]

1. When UART Interface : VCC > 5.5V

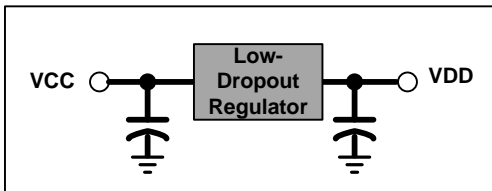

or

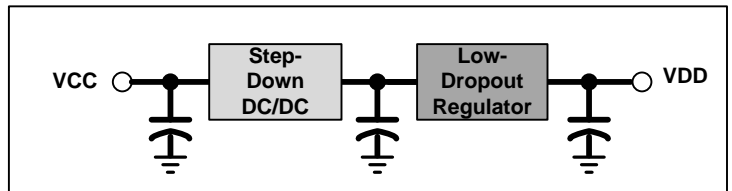

2. When UART Interface : VCC < 4.75V

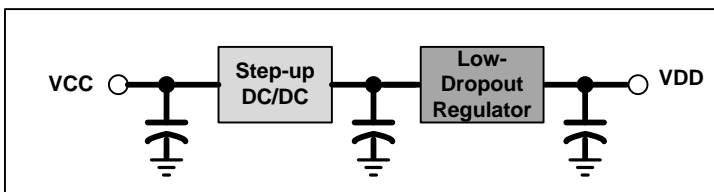

3. When USB Interface :

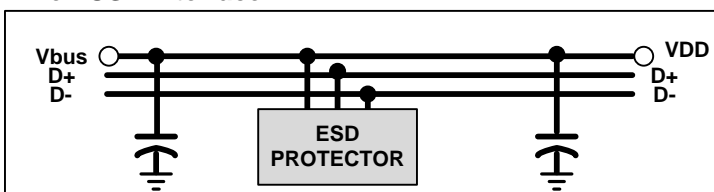

SPECIFICATIONS

POWER REQUIREMENTS	4.75 ~ 5.5V (5.3V is recommended.) regulated for Operate Voltage . A linear regulator is recommended.
CURRENT CONSUMPTION	50 mA AVG @ Standby Mode 250 mA AVG @ 22dBm RF Power Output
RFID PROTOCOL SUPPORT	EPC Class 1 Gen 2, ISO18000-6C
SUPPORT EPC DRM	Yes
FREQUENCY	840 ~ 960MHz
DEMODULATION	ASK or PSK
DATA ENCODING	FM0 or Miller code
BIT RATE	Supports uplink data rate of 40,160,320 Kbps
TX OUTPUT POWER	10 ~ 22 dBm
ANTENNA TYPE	Mono-static
HOST INTERFACE	UART (Default : 19200 Baud rate) Programmable USB HID
INPUT / OUTPUT PIN	Programmable 12 Input / Output Pin by Customer
CONFIGURE INTERFACE	UART , 19200 bps 8N1
DIMENSIONS	30 x 20 x 3.6 mm
WEIGHT	< 10 gm
ENVIRONMENT	Operating Temp : -0°C ~ +60°C Humidity : 10 ~ 90 % Non-condensing

PACKAGE DESCRIPTION

34-Pin SMD Package
Dimensions in Millimeters

